

XC74UL02AA



CMOS Logic

- ◆ CMOS 2-Input NOR Gate
- ◆ High Speed Operation : tpd=2.65ns TYP
- ◆ Operating Voltage Range : 2V~5.5V
- ◆ Low Power Consumption : 1 μ A (max)

General Description

The XC74UL02AA is a 2-input CMOS NOR gate, manufactured using silicon gate CMOS fabrication.

CMOS low power circuit operation makes high speed LS-TTL operations achievable.

With a wave forming buffer connected internally, stabilized output can be achieved as the circuit offers high noise immunity.

As the XC74UL02AA is integrated into mini molded, SSOT-25 and SOT-25 packages, high density mounting is possible.

Pin Configuration

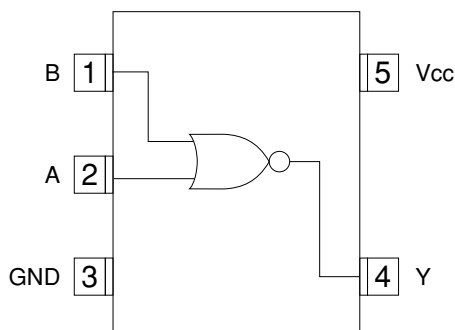

SSOT-25/SOT-25
(TOP VIEW)

Absolute Maximum Ratings

Ta=-40°C~85°C

PARAMETER	SYMBOL	RATINGS	UNITS
Power Supply Voltage	VCC	-0.5 ~ +6.0	V
Input Voltage	VIN	-0.5 ~ +6.0	V
Output Voltage	VOUT	-0.5 ~ VCC +0.5	V
Input Diode Current	I _{IK}	-20	mA
Output Diode Current	I _{OK}	±20	mA
Output Current	I _{OUT}	±25	mA
VCC ,GND Current	I _{CC} ,I _{GND}	±50	mA
Continuous Total Power Dissipation (Ta=55°C)	P _d	150	mW
Storage Temperature	T _{stg}	-65 ~ +150	°C

Note: Voltage is all Ground standardized.

Applications

- Palmtops
- Digital Equipment

Features

- High Speed Operation : tpd=2.65ns TYP
- Operating Voltage Range: 2V~5.5V
- Low Power Consumption: 1 μ A (max)
- Ultra Small Package : SSOT-25 and SOT-25

Function

INPUT		OUTPUT
A	B	Y
L	L	H
L	H	H
H	L	H
H	H	L

H=High level, L=Low level

Recommended Operating Conditions

PARAMETER	SYMBOL	V _{CC} (V)	CONDITIONS	UNITS
Supply Voltage	V _{CC}	-	2 ~ 5.5	V
Input Voltage	V _{IN}	-	0 ~ 5.5	V
Output Voltage	V _{OUT}	-	0 ~ V _{CC}	V
Operating Temperature	T _{opr}	-	-40 ~ +85	°C
Output Current	I _{OH}	3.0	-4	mA
		4.5	-8	
	I _{OL}	3.0	4	
		4.5	8	
Input Rise and Fall Time	t _r , t _f	3.3	0 ~ 100	ns
		5.0	0 ~ 20	

DC Electrical Characteristics

PARAMETER	SYMBOL	V _{CC} (V)	CONDITIONS	Ta=25°C			Ta=-40~85°C		UNITS	
				MIN	TYP	MAX	MIN	MAX		
Input Voltage	V _{IH}	2.0		1.5	-	-	1.5	-	V	
		3.0		2.1	-	-	2.1	-		
		5.5		3.85	-	-	3.85	-		
	V _{IL}	2.0		-	-	0.5	-	0.5	V	
		3.0		-	-	0.9	-	0.9		
		5.5		-	-	1.65	-	1.65		
Output Voltage	V _{OH}	2.0	V _{IN} =V _{IH} or V _{IL}	I _{OH} =-50μA	1.9	2.0	-	1.9	-	V
		3.0			2.9	3.0	-	2.9	-	
		4.5			4.4	4.5	-	4.4	-	
		3.0			2.58	-	-	2.48	-	
		4.5			3.94	-	-	3.80	-	
	V _{OL}	V _{IN} =V _{IH}	I _{OL} =50μA	2.0	-	-	0.1	-	0.1	V
				3.0	-	-	0.1	-	0.1	
				4.5	-	-	0.1	-	0.1	
				3.0	-	-	0.36	-	0.44	
				4.5	-	-	0.36	-	0.44	
Input Current	I _{IN}	5.5	V _{IN} =V _{CC} or GND	-0.1	-	0.1	-1.0	1.0	μA	
Quiescent Supply Current	I _{CC}	5.5	V _{IN} =V _{CC} or GND, I _{OUT} =0μA	-	-	1.0	-	10.0		

Switching Electrical Characteristics

t_r=t_f=3ns

PARAMETER	SYMBOL	C _L	V _{CC} (V)	CONDITIONS	Ta=25°C			Ta=-40~85°C		UNITS
					MIN	TYP	MAX	MIN	MAX	
Propagation Delay Time	t _{PLH}	15pF	3.3		-	3.9	7.9	1.0	9.5	ns
			5.0		-	2.7	5.5	1.0	6.5	
		50pF	3.3		-	5.5	11.4	1.0	13	ns
			5.0		-	3.9	7.5	1.0	8.5	
	t _{PHL}	15pF	3.3		-	3.5	7.9	1.0	9.5	ns
			5.0		-	2.6	5.5	1.0	6.5	
50pF		3.3	-	4.9	11.4	1.0	13	ns		
		5.0	-	3.6	7.5	1.0	8.5			
Input Capacitance	C _{IN}	-	5.0	V _{IN} =V _{CC} or GND	-	4	10	-	10	pF
Power Dissipation Capacitance	C _{pd}	No Load, f=1MHz			-	9.7	-	-	-	pF

■ Waveforms

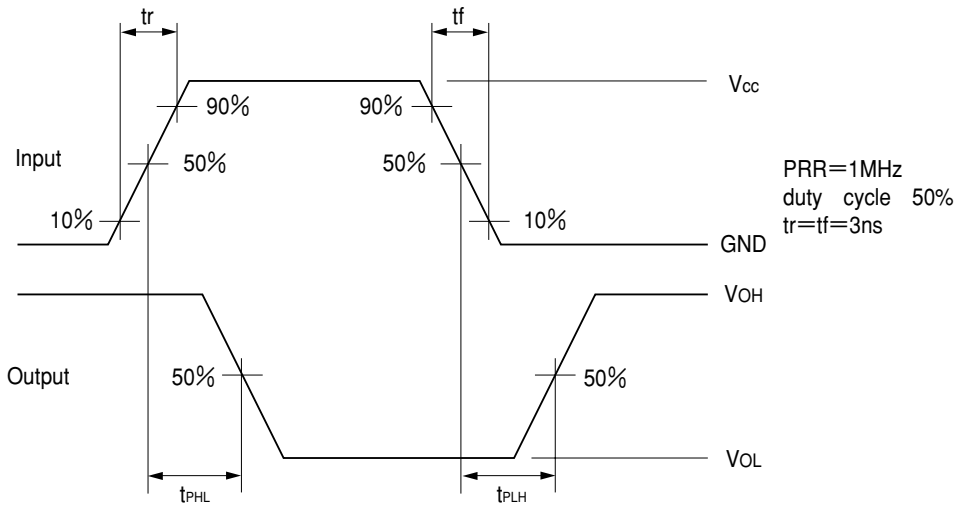

■ Typical Application Circuit

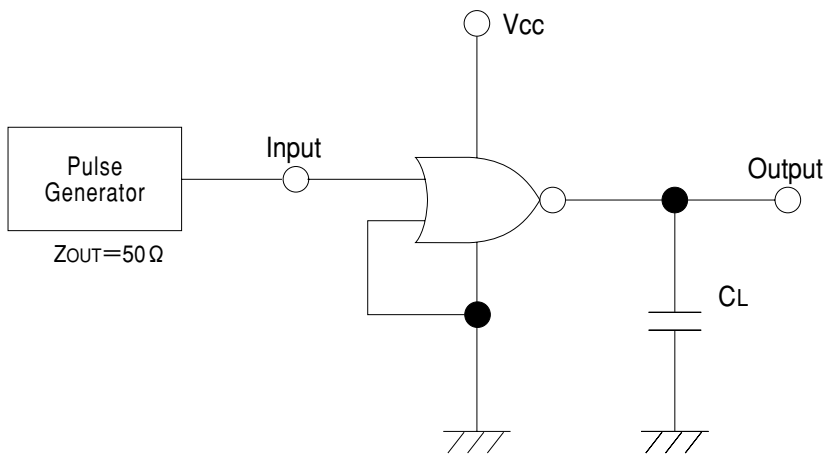

Note: Open output when measuring supply current