

Automotive fully integrated H-bridge motor driver

Features

Type	$R_{DS(on)}$	I_{out}	V_{CCmax}
VNH5180A-E	180 mΩ max (per leg)	8 A	41 V

- Output current: 8 A
- 3 V CMOS compatible inputs
- Undervoltage shutdown
- Overvoltage clamp
- Thermal shutdown
- Cross-conduction protection
- Current and power limitation
- Very low standby power consumption
- PWM operation up to 20 KHz
- Protection against loss of ground and loss of V_{CC}
- Current sense output proportional to motor current
- Output protected against short to ground and short to V_{CC}
- Package: ECOPACK®

Description

The VNH5180A-E is a full bridge motor driver intended for a wide range of automotive applications. The device incorporates a dual monolithic high-side driver and two low-side switches. Both switches are designed using STMicroelectronics' well known and proven



proprietary VIPower® M0 technology that allows to efficiently integrate on the same die a true Power MOSFET with an intelligent signal/protection circuitry. The three dies are assembled in PowerSSO-36 TP package on electrically isolated leadframes. This package, specifically designed for the harsh automotive environment offers improved thermal performance thanks to exposed die pads. Moreover, its fully symmetrical mechanical design allows superior manufacturability at board level. The input signals IN_A and IN_B can directly interface to the microcontroller to select the motor direction and the brake condition. The $DIAG_A/EN_A$ or $DIAG_B/EN_B$, when connected to an external pull-up resistor, enables one leg of the bridge. Each $DIAG_A/EN_A$ provides a feedback digital diagnostic signal as well. The normal operating condition is explained in the truth table. The CS pin allows to monitor the motor current by delivering a current proportional to its value when CS_DIS pin is driven low or left open. When CS_DIS is driven high, CS pin is in high impedance condition. The PWM, up to 20 KHz, allows to control the speed of the motor in all possible conditions. In all cases, a low level state on the PWM pin turns off both the LS_A and LS_B switches.

Table 1. Device summary

Package	Order codes	
	Tube	Tape and reel
PowerSSO-36 TP	VNH5180A-E	VNH5180ATR-E

Contents

- 1 Block diagram and pin description 5**
- 2 Electrical specifications 8**
 - 2.1 Absolute maximum ratings 8
 - 2.2 Thermal data 9
 - 2.3 Electrical characteristics 9
 - 2.4 Waveforms 17
- 3 Application information 19**
 - 3.1 Reverse battery protection 20
- 4 Package and PCB thermal data 22**
 - 4.1 PowerSSO-36 thermal data 22
 - 4.1.1 Thermal calculation in clockwise and anti-clockwise operation in steady-state mode 23
 - 4.1.2 Thermal calculation in transient mode 24
- 5 Package and packing information 27**
 - 5.1 ECOPACK® 27
 - 5.2 PowerSSO-36 TP package information 27
 - 5.3 PowerSSO-36 TP packing information 29
- 6 Revision history 30**

List of tables

Table 1.	Device summary	1
Table 2.	Block description	5
Table 3.	Suggested connections for unused and not connected pins	6
Table 4.	Pin definitions and functions	6
Table 5.	Pin functions description	7
Table 6.	Absolute maximum ratings	8
Table 7.	Thermal data	9
Table 8.	Power section	9
Table 9.	Logic inputs (INA, INB, ENA, ENB, PWM, CS_DIS)	10
Table 10.	Switching (VCC = 13 V, RLOAD = 5 W)	10
Table 11.	Protections and diagnostics	11
Table 12.	Current sense (9 V < VCC < 18 V)	11
Table 13.	Truth table in normal operating conditions	15
Table 14.	Truth table in fault conditions (detected on OUTA)	15
Table 15.	Electrical transient requirements (part 1)	16
Table 16.	Electrical transient requirements (part 2)	16
Table 17.	Electrical transient requirements (part 3)	16
Table 18.	Thermal calculation in clockwise and anti-clockwise operation in steady-state mode	23
Table 19.	Thermal parameters	26
Table 20.	PowerSSO-36 TP mechanical data	28
Table 21.	Document revision history	30

List of figures

Figure 1.	Block diagram	5
Figure 2.	Configuration diagram (top view)	6
Figure 3.	Current and voltage conventions	8
Figure 4.	Definition of the delay times measurement	12
Figure 5.	Definition of the low-side switching times	13
Figure 6.	Definition of the high-side switching times	13
Figure 7.	Definition of dynamic cross conduction current during a PWM operation.	14
Figure 8.	Definition of delay response time of sense current.	14
Figure 9.	Waveforms in full-bridge operation	17
Figure 10.	Waveforms in full-bridge operation (continued)	18
Figure 11.	Typical application circuit for DC to 20 kHz PWM operation short circuit protection	19
Figure 12.	Behavior in fault condition (how a fault can be cleared)	20
Figure 13.	Half-bridge configuration.	21
Figure 14.	Multi-motors configuration	21
Figure 15.	PowerSSO-36™ PC board.	22
Figure 16.	Chipset configuration	23
Figure 17.	Auto and mutual Rthj-amb vs PCB copper area in open box free air condition	23
Figure 18.	Detailed chipset configuration.	24
Figure 19.	PowerSSO-36 HSD thermal impedance junction ambient single pulse	25
Figure 20.	PowerSSO-36 LSD thermal impedance junction ambient single pulse	25
Figure 21.	Thermal fitting model of an H-bridge in PowerSSO-36.	26
Figure 22.	PowerSSO-36 TP package dimensions	27
Figure 23.	PowerSSO-36 TP tube shipment (no suffix).	29
Figure 24.	PowerSSO-36 TP tape and reel shipment (suffix "TR")	29

1 Block diagram and pin description

Figure 1. Block diagram

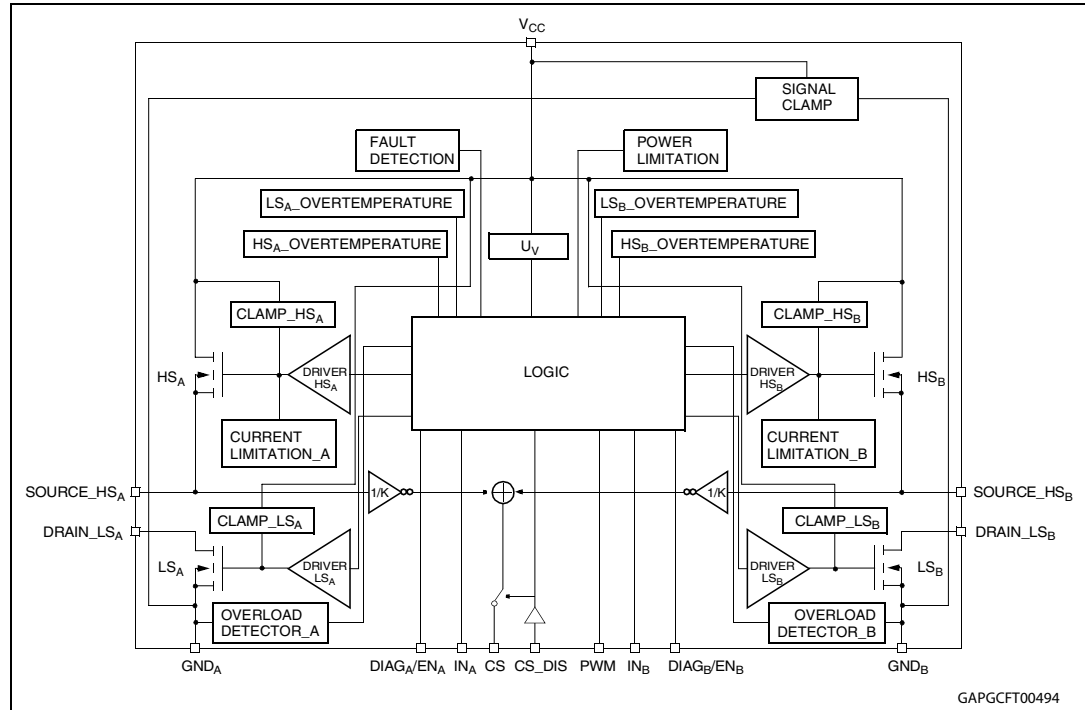

Table 2. Block description

Name	Description
Logic control	Allows the turn-on and the turn-off of the high-side and the low-side switches according to the truth table.
Undervoltage	Shuts down the device for battery voltage lower than 5V.
High-side and low-side clamp voltage	Protect the high-side and the low-side switches from the high voltage on the battery line.
High-side and low-side driver	Drive the gate of the concerned switch to allow a proper $R_{DS(on)}$ for the leg of the bridge.
Current limitation	Limits the motor current in case of short circuit.
High-side and low-side overtemperature protection	In case of short-circuit with the increase of the junction temperature, it shuts down the concerned driver to prevent degradation and to protect the die.
Low-side overload detector	Detects when low side current exceeds shutdown current and latches off the concerned Low side.
Fault detection	Signalizes the abnormal behaviour of the switch (output shorted to ground or output shorted to battery) by pulling down the concerned ENx/DIAGx pin.
Power limitation	Limits the power dissipation of the high-side driver inside safe range in case of short to ground condition.

Figure 2. Configuration diagram (top view)

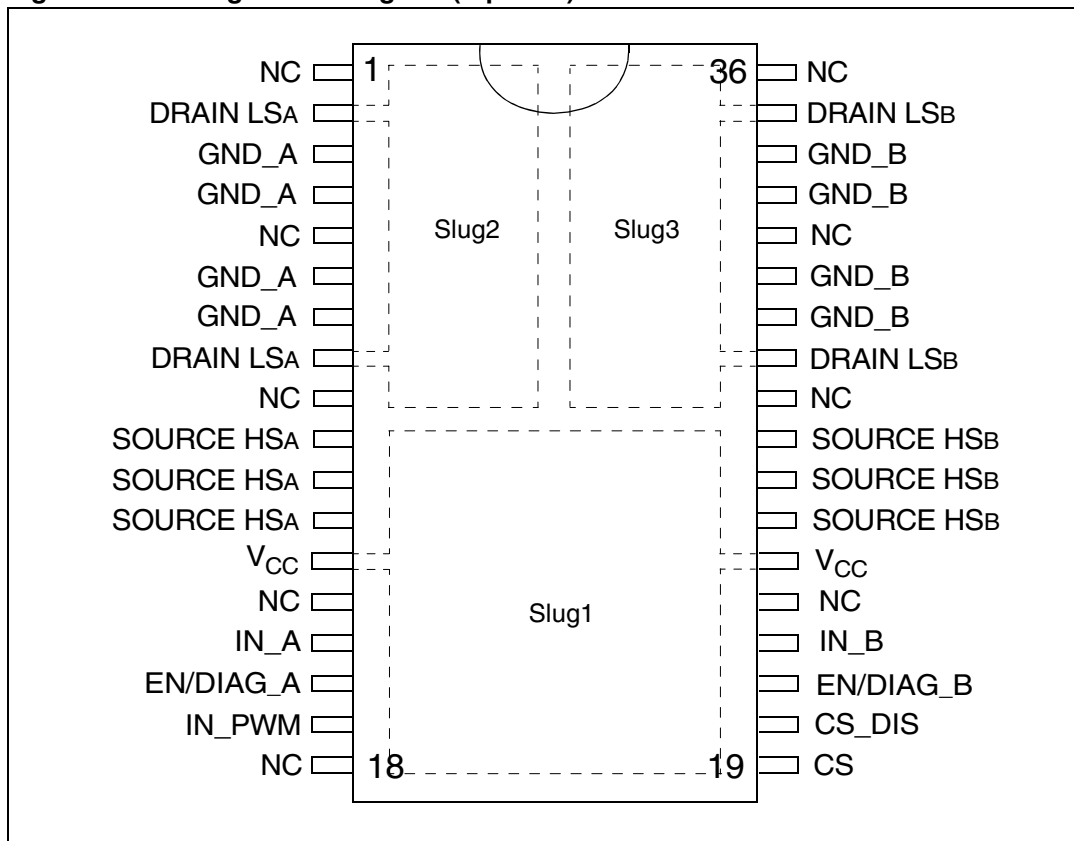

Table 3. Suggested connections for unused and not connected pins

Connection / pin	Current sense	N.C.	SOURCE_HSx	DRAIN_LSx	INPUTx, PWM DIAGx/ENx CS_DIS
Floating	Not allowed	X	X	X	X
To ground	Through 1 kΩ resistor	X	Not allowed	X	Through 10 kΩ resistor

Table 4. Pin definitions and functions

Pin N°	Symbol	Function
13, 24	V _{CC} , Heat Slug1	Drain of high-side switches and power supply voltage.
1, 5, 9, 14, 18, 23, 28, 32, 36	NC	Not connected.
15	INA	Clockwise input
16	ENA/DIAGA	Status of high-side and low-side switches A; open drain output.
17	IN_PWM	PWM input.
19	CS	Output of current sense.

Table 4. Pin definitions and functions (continued)

Pin N°	Symbol	Function
20	CS_DIS	Active high CMOS compatible pin to disable current sense pin.
21	EN _B /DIAG _B	Status of high-side and low-side switches b; open drain output.
22	IN _B	Counter clockwise input.
25, 26, 27, 29, 35	OUT _B , Heat Slug3	Source of high-side switch B / drain of low-side switch B.
30, 31, 33, 34	GND _B	Source of low-side switch B.
2, 8, 10, 11, 12	OUT _A , Heat Slug2	Source of high-side switch A / drain of low-side switch A.
3, 4, 6, 7	GND _A	Source of low-side switch A.

Table 5. Pin functions description

Name	Description
V _{CC}	Battery connection.
GND	Power ground.
OUT _A OUT _B	Power connections to the motor.
IN _A IN _B	Voltage controlled input pins with hysteresis, CMOS compatible. These two pins control the state of the bridge in normal operation according to the truth table (brake to V _{CC} , Brake to GND, clockwise and counterclockwise).
PWM	Voltage controlled input pin with hysteresis, CMOS compatible. Gates of low-side FETS get modulated by the PWM signal during their ON phase allowing speed control of the motor.
EN _A /DIAG _A EN _B /DIAG _B	Open drain bidirectional logic pins. These pins must be connected to an external pull up resistor. When externally pulled low, they disable half-bridge A or B. In case of fault detection (thermal shutdown of a high-side FET or excessive ON-state voltage drop across a low-side FET), these pins are pulled low by the device (see Table 14: Truth table in fault conditions (detected on OUT_A)).
CS	Analog current sense output. This output delivers a current proportional to the motor current if CS_DIS is low or left open. The information can be read back as an analog voltage across an external resistor.
CS_DIS	Active high CMOS compatible pin to disable the current sense pin.

2 Electrical specifications

Figure 3. Current and voltage conventions

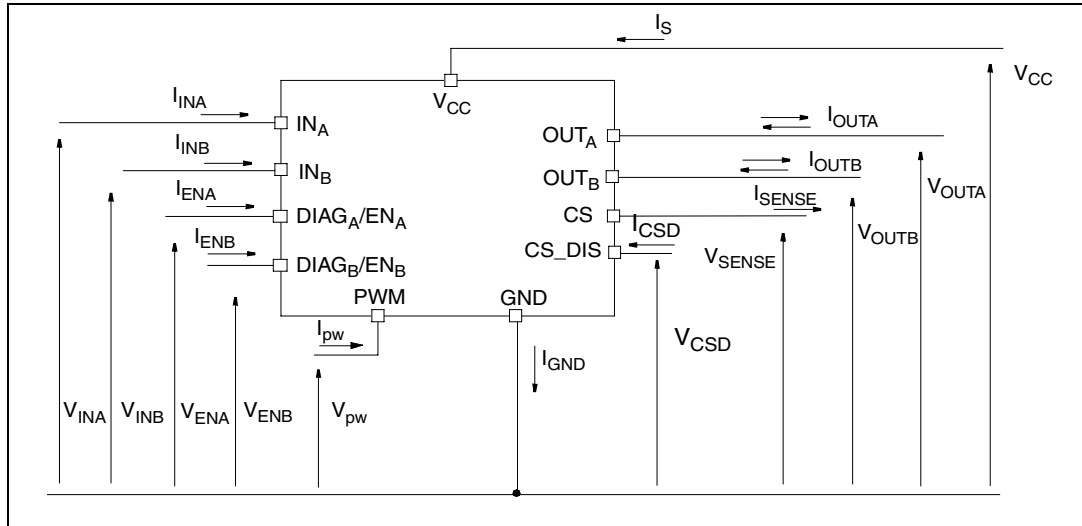

2.1 Absolute maximum ratings

Stressing the device above the rating listed in the [Table 6: Absolute maximum ratings](#) may cause permanent damage to the device. These are stress ratings only and operation of the device at these or any other conditions above those indicated in the Operating sections of this specification is not implied. Exposure to Absolute Maximum Rating conditions for extended periods may affect device reliability. Refer also to the STMicroelectronics SURE Program and other relevant quality document.

Table 6. Absolute maximum ratings

Symbol	Parameter	Value	Unit
V_{CC}	Supply voltage	+ 41	V
I_{max}	Maximum output current (continuous)	Internally limited	A
I_R	Reverse output current (continuous)	-15	A
I_{IN}	Input current (IN_A and IN_B pins)	+/- 10	mA
I_{EN}	Enable input current ($DIAG_A/EN_A$ and $DIAG_B/EN_B$ pins)	+/- 10	mA
I_{pw}	PWM Input current	+/- 10	mA
I_{CS_DIS}	CS_DIS input current	+/- 10	mA
V_{CS}	Current sense maximum voltage	$V_{CC}-41/+V_{CC}$	V
V_{ESD}	Electrostatic discharge (Human body model: $R=1.5\text{ k}\Omega$, $C=100\text{ pF}$)	2	kV
T_c	Junction operating temperature	-40 to 150	$^{\circ}\text{C}$
T_{STG}	Storage temperature	-55 to 150	$^{\circ}\text{C}$
I_{GND}	DC reverse ground pin current	200	mA

2.2 Thermal data

Table 7. Thermal data

Symbol	Parameter	Max. value	Unit
$R_{thj-case}$	Thermal resistance junction-case (per leg)	HSD	4.8
		LSD	4.6
$R_{thj-amb}$	Thermal resistance junction-ambient	See Figure 17	°C/W

2.3 Electrical characteristics

Values specified in this section are for $V_{CC} = 9\text{ V}$ up to 18 V ; $-40\text{ °C} < T_J < 150\text{ °C}$, unless otherwise specified.

Table 8. Power section

Symbol	Parameter	Test conditions	Min.	Typ.	Max.	Unit
V_{CC}	Operating supply voltage		5.5		18	V
I_S	Supply current	Off-state with all fault cleared and $EN_x = 0$ (standby) $I_{N_A} = I_{N_B} = PWM = 0$; $T_j = 25\text{ °C}$; $V_{CC} = 13\text{ V}$		3	6	μA
		Off-state with all fault cleared and $EN_x = 0$ (standby) $I_{N_A} = I_{N_B} = PWM = 0$; $V_{CC} = 13\text{ V}$; $T_j = -40\text{ to }150\text{ °C}$			10	μA
		Off-state (no standby) $I_{N_A} = I_{N_B} = PWM = 0$; $EN_x = 5\text{ V}$; $T_j = -40\text{ to }150\text{ °C}$			5	mA
		On-state: I_{N_A} or $I_{N_B} = 5\text{ V}$; no PWM		3	6	mA
		On-state: I_{N_A} or $I_{N_B} = 5\text{ V}$; PWM = 20 kHz			6	mA
R_{ONHS}	Static high-side resistance	$I_{OUT} = 2.5\text{ A}$; $T_j = -40\text{ °C}$		75		m Ω
		$I_{OUT} = 2.5\text{ A}$; $T_j = 25\text{ °C}$		115		m Ω
		$I_{OUT} = 2.5\text{ A}$; $T_j = 150\text{ °C}$		230		m Ω
		$I_{OUT} = 2.5\text{ A}$; $T_j = -40\text{ to }150\text{ °C}$			250	m Ω
R_{ONLS}	Static low-side resistance	$I_{OUT} = 2.5\text{ A}$; $T_j = 25\text{ °C}$		53.5		m Ω
		$I_{OUT} = 2.5\text{ A}$; $T_j = -40\text{ to }150\text{ °C}$			110	m Ω
V_f	High-side free-wheeling diode forward voltage	$I_{OUT} = -2.5\text{ A}$; $T_j = 150\text{ °C}$		0.7	0.9	V

Table 8. Power section (continued)

Symbol	Parameter	Test conditions	Min.	Typ.	Max.	Unit
$I_{L(off)}$	High-side off-state output current (per channel)	$T_j = 25\text{ °C}; V_{OUTX} = EN_X = 0\text{ V}; V_{CC} = 13\text{ V}$	0		3	μA
		$T_j = 125\text{ °C}; V_{OUTX} = EN_X = 0\text{ V}; V_{CC} = 13\text{ V}$	0		5	μA
I_{RM}	Dynamic cross-conduction current	$I_{OUT} = 2.5\text{ A}$ (see Figure 6)		0.6		A

Table 9. Logic inputs (IN_A , IN_B , EN_A , EN_B , PWM, CS_DIS)

Symbol	Parameter	Test conditions	Min.	Typ.	Max.	Unit
V_{IL}	Input low level voltage	Normal operation (DIAG _X /EN _X pin acts as an input pin)			0.9	V
V_{IH}	Input high level voltage	Normal operation (DIAG _X /EN _X pin acts as an input pin)	2.1			V
V_{IHYST}	Input hysteresis voltage	Normal operation (DIAG _X /EN _X pin acts as an input pin)	0.15			V
V_{ICL}	Input clamp voltage	$I_{IN} = 1\text{ mA}$	5.5	6.3	7.5	V
		$I_{IN} = -1\text{ mA}$	-1.0	-0.7	-0.3	V
I_{INL}	Input current	$V_{IN} = 0.9\text{ V}$	1			μA
I_{INH}	Input current	$V_{IN} = 2.1\text{ V}$			10	μA
V_{DIAG}	Enable output low level voltage	Fault operation (DIAG _X /EN _X pin acts as an output pin); $I_{EN} = 1\text{ mA}$			0.4	V

Table 10. Switching ($V_{CC} = 13\text{ V}$, $R_{LOAD} = 5\ \Omega$)

Symbol	Parameter	Test conditions	Min.	Typ.	Max.	Unit
f	PWM frequency		0		20	kHz
$t_{d(on)}$	Turn-on delay time	Input rise time < 1 μs (see Figure 6)			250	μs
$t_{d(off)}$	Turn-off delay time	Input rise time < 1 μs (see Figure 6)			250	μs
t_r	Rise time	See Figure 5		1	2	μs
t_f	Fall time	See Figure 5		1	2	μs
t_{DEL}	Delay time during change of operating mode	See Figure 4	200	400	1600	μs
t_{rr}	High-side free wheeling diode reverse recovery time	See Figure 7		400		ns

Table 11. Protections and diagnostics

Symbol	Parameter	Test conditions	Min.	Typ.	Max.	Unit
V_{USD}	Undervoltage shutdown			3	5	V
$V_{USDhyst}$	Undervoltage shutdown hysteresis			0.5		V
I_{LIM_H}	High-side current limitation		8	12	16	A
I_{SD_LS}	Shutdown LS current		16	30	52	A
V_{CLPH}	High-side clamp voltage (V_{CC} to $OUT_A = 0$ or $OUT_B = 0$)	$I_{OUT} = 2.5$ A	41	46	52	V
V_{CLPLS}	Low-side clamp voltage ($OUT_A = V_{CC}$ or $OUT_B = V_{CC}$ to GND)	$I_{OUT} = 2.5$ A	41	46	52	V
$T_{TSD}^{(1)}$	Thermal shutdown temperature	$V_{IN} = 2.1$ V	150	175	200	°C
$T_{TR}^{(2)}$	Thermal reset temperature		135			°C
$T_{HYST}^{(2)}$	Thermal hysteresis ($T_{SD} - T_R$)			7		°C
T_{TSD_LS}	Low-side thermal shutdown temperature	$V_{IN} = 2.1$ V	150	175	200	°C
V_{CLP}	Total clamp voltage (V_{CC} to GND)	$I_{OUT} = 2.5$ A	41	46	52	V
t_{SD_LS}	Time to shutdown for the low-side			10		µs

1. T_{TSD} is the minimum threshold temperature between HS and LS

2. Valid for both HSD and LSD.

Table 12. Current sense (9 V < V_{CC} < 18 V)

Symbol	Parameter	Test conditions	Min.	Typ.	Max.	Unit
K_0	I_{OUT}/I_{SENSE}	$I_{OUT} = 0.35$ A; $V_{SENSE} = 0.32$ V; $V_{CSD} = 0$ V; $T_j = -40$ to 150 °C	645	840	1140	
K_1	I_{OUT}/I_{SENSE}	$I_{OUT} = 1$ A; $V_{SENSE} = 0.98$ V; $V_{CSD} = 0$ V; $T_j = -40$ to 150 °C	700	820	955	
K_2	I_{OUT}/I_{SENSE}	$I_{OUT} = 2.5$ A; $V_{SENSE} = 2.4$ V; $V_{CSD} = 0$ V; $T_j = -40$ to 150 °C	710	810	900	
K_3	I_{OUT}/I_{SENSE}	$I_{OUT} = 4$ A; $V_{SENSE} = 4$ V; $V_{CSD} = 0$ V; $T_j = -40$ to 150 °C	690	790	900	
$dK_0/K_0^{(1)}$	Analog sense current drift	$I_{OUT} = 0.35$ A; $V_{SENSE} = 0.32$ V; $V_{CSD} = 0$ V; $T_j = -40$ to 150 °C	-18		18	%
$dK_1/K_1^{(1)}$	Analog sense current drift	$I_{OUT} = 1$ A; $V_{SENSE} = 0.98$ V; $V_{CSD} = 0$ V; $T_j = -40$ to 150 °C	-13		13	%
$dK_2/K_2^{(1)}$	Analog sense current drift	$I_{OUT} = 2.5$ A; $V_{SENSE} = 2.4$ V; $V_{CSD} = 0$ V; $T_j = -40$ to 150 °C	-13		13	%
$dK_3/K_3^{(1)}$	Analog sense current drift	$I_{OUT} = 4$ A; $V_{SENSE} = 4$ V; $V_{CSD} = 0$ V; $T_j = -40$ to 150 °C	-13		13	%
V_{SENSE}	Max analog sense output voltage	$I_{OUT} = 2.5$ A; $V_{CSD} = 0$ V; $R_{SENSE} = 2$ KΩ	5			V

Table 12. Current sense (9 V < V_{CC} < 18 V) (continued)

Symbol	Parameter	Test conditions	Min.	Typ.	Max.	Unit
I _{SENSE0}	Analog sense leakage current	I _{OUT} = 0 A; V _{SENSE} = 0 V; V _{CSD} = 5 V; V _{IN} = 0 V; T _j = - 40 to 150 °C	0		5	μA
		V _{CSD} = 0 V; V _{IN} = 5 V; T _j = - 40 to 150 °C	0		180	μA
		V _{CSD} = 5 V; V _{IN} = 5 V; I _{OUT} = 2.5 A; T _j = - 40 to 150 °C	0		5	μA
t _{DSENSEH}	Delay response time from falling edge of CS_DIS pin	V _{IN} = 5 V; V _{SENSE} < 4 V; I _{OUT} = 2.5 A, I _{SENSE} = 90 % of I _{SENSEmax} (see Figure 8)			50	μs
t _{DSENSEL}	Delay response time from rising edge of CS_DIS pin	V _{IN} = 5 V; V _{SENSE} < 4 V; I _{OUT} = 2.5 A; I _{SENSE} = 10 % of I _{SENSEmax} (see Figure 8)			20	μs

1. Analog sense current drift is deviation of factor K for a given device over (-40 °C to 150 °C and 9 V < V_{CC} < 18 V) with respect to its value measured at T_j = 25 °C, V_{CC} = 13 V.

Figure 4. Definition of the delay times measurement

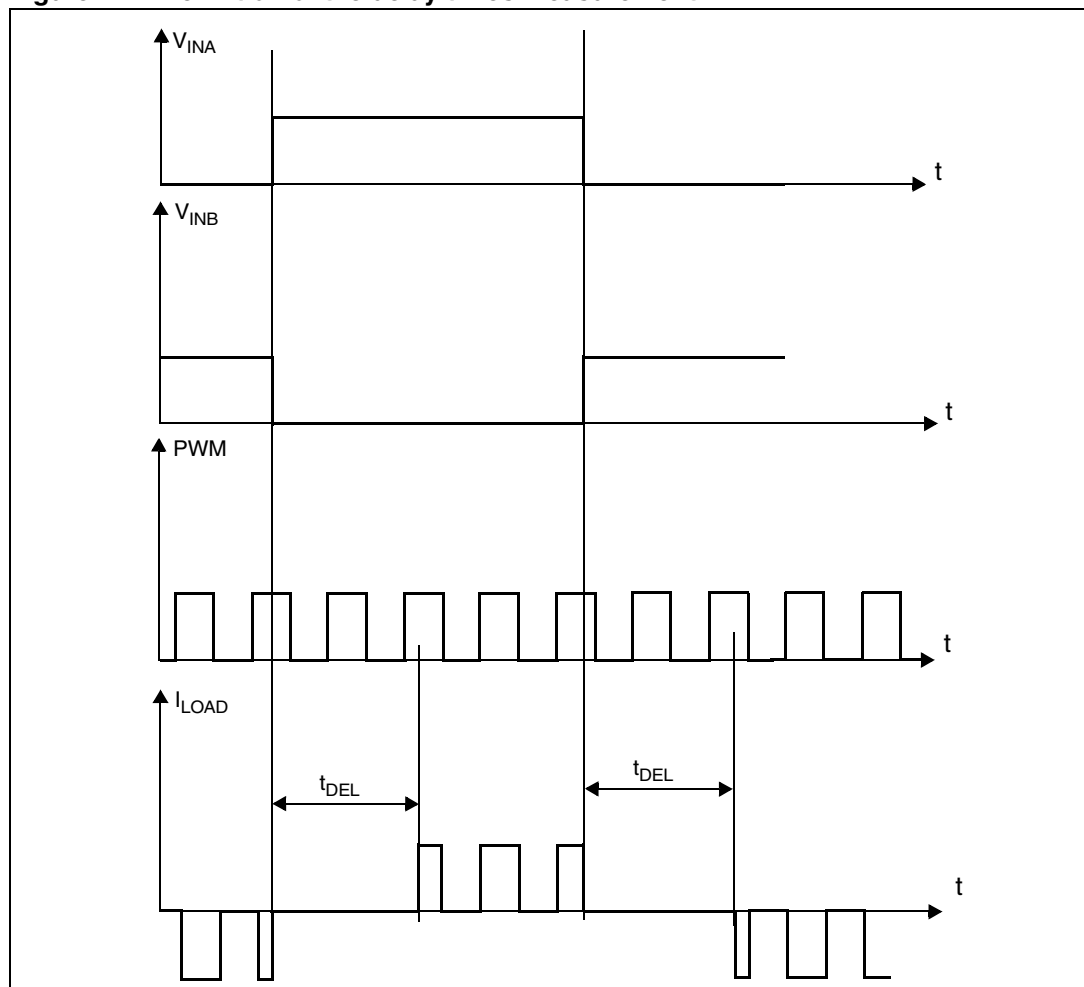

Figure 5. Definition of the low-side switching times

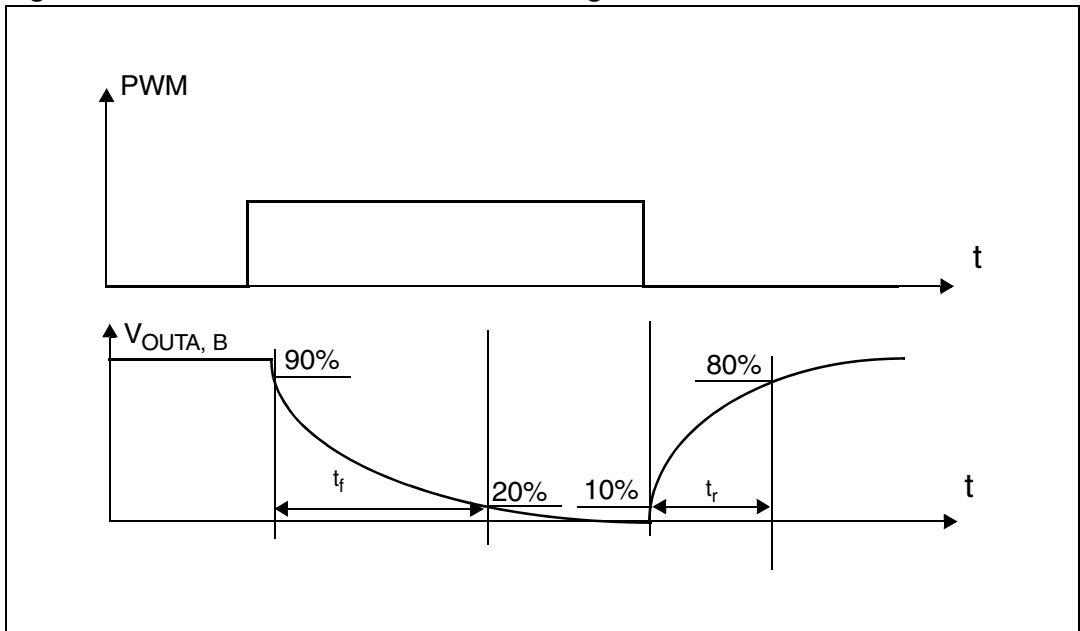

Figure 6. Definition of the high-side switching times

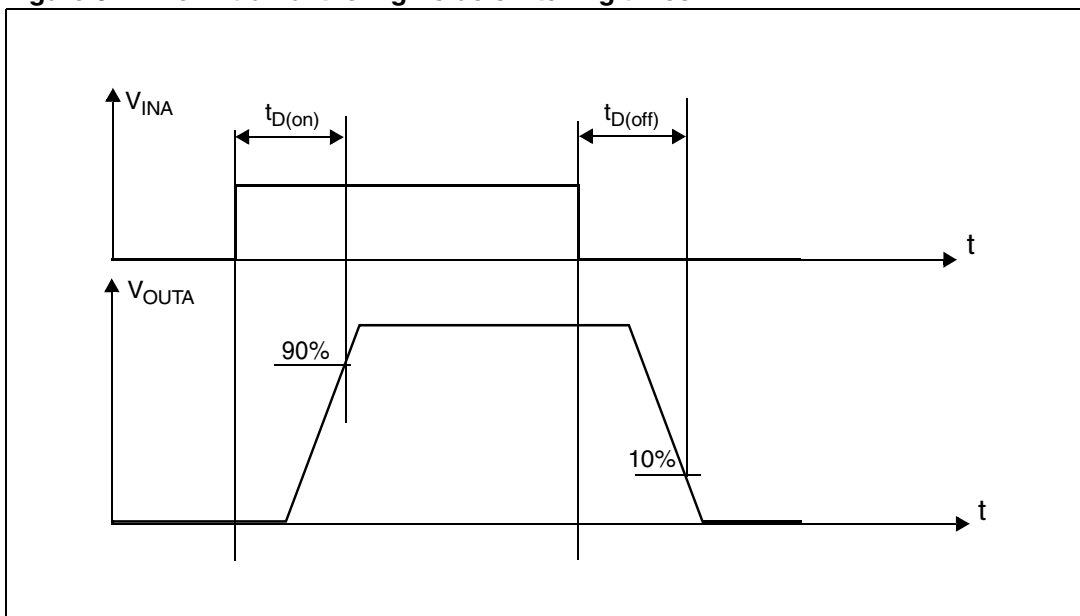

Figure 7. Definition of dynamic cross conduction current during a PWM operation

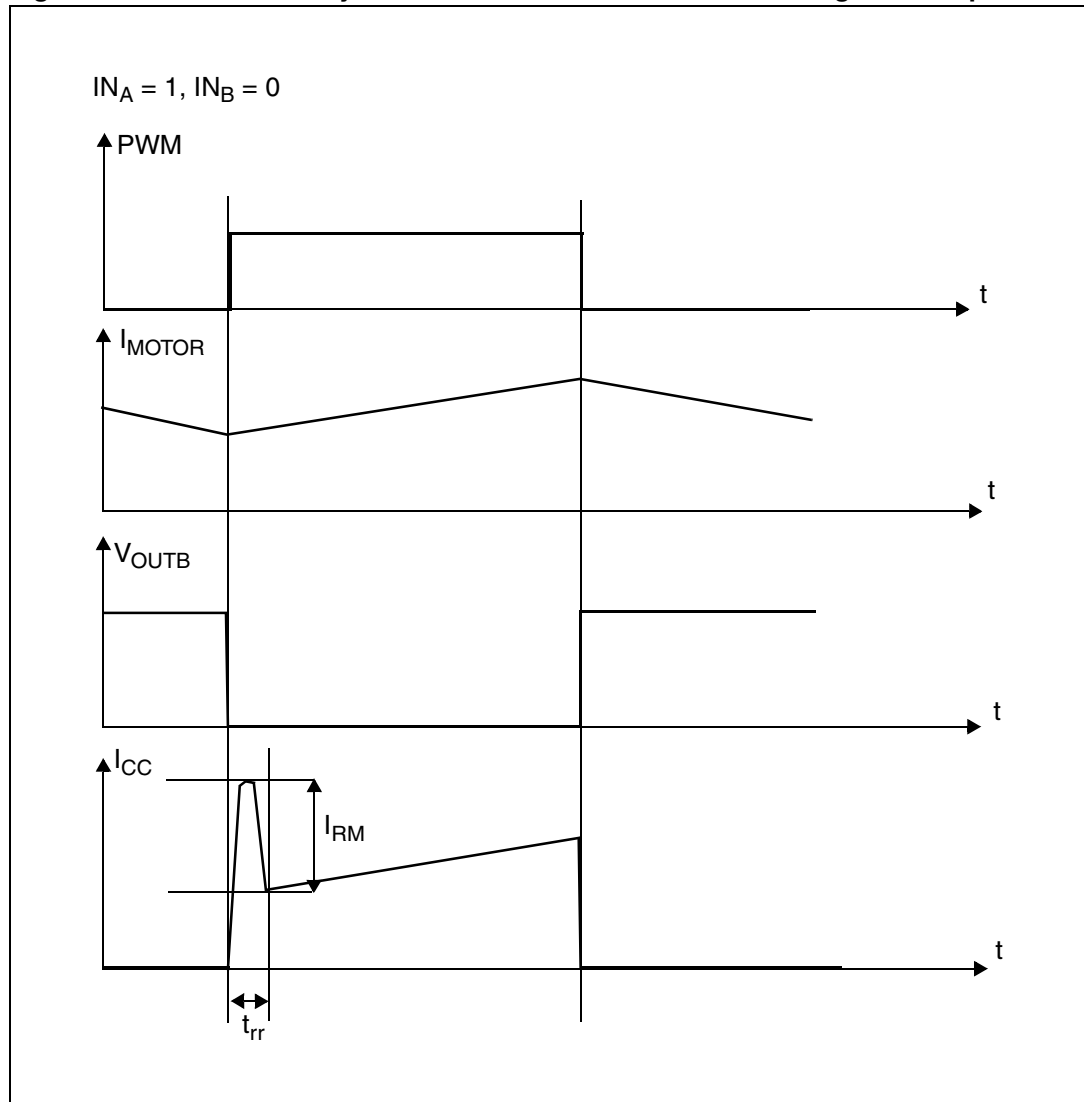

Figure 8. Definition of delay response time of sense current

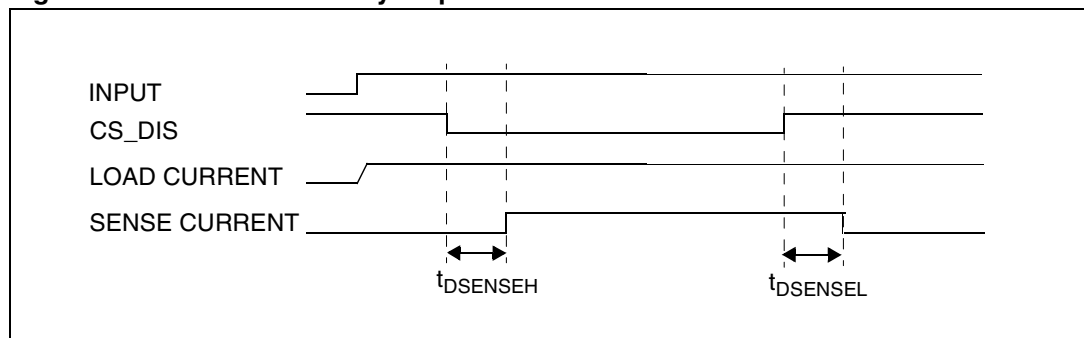

Table 13. Truth table in normal operating conditions

IN _A	IN _B	DIAG _A /EN _A	DIAG _B /EN _B	OUT _A	OUT _B	CS	Operating mode
1	1	1	1	H	H	High Imp.	Brake to V _{CC}
	L				I _{SENSE} = I _{OUT} /K	Clockwise (CW)	
0	1			H		Counterclockwise (CCW)	
	0			L	High Imp.	Brake to GND	

Table 14. Truth table in fault conditions (detected on OUT_A)

IN _A	IN _B	DIAG _A /EN _A	DIAG _B /EN _B	OUT _A	OUT _B	CS (V _{CSD} =0V)
1	1	0	1	OPEN	H	High Imp.
	0				L	
0	1				H	I _{OUTB} /K
	0				L	High Imp.
X	X		0	OPEN		

↑
↑
↑
↑

Fault Information
Protection Action

Note: In normal operating conditions the DIAG_X/EN_X pin is considered as an input pin by the device. This pin must be externally pulled high.

Table 15. Electrical transient requirements (part 1)

ISO 7637-2: 2004(E) Test pulse	Test levels ⁽¹⁾		Number of pulses or test times	Burst cycle/pulse repetition time		Delays and Impedance
	III	IV		Min.	Max.	
1	-75V	-100V	5000 pulses	0.5s	5s	2 ms, 10Ω
2a	+37V	+50V	5000 pulses	0.2s	5s	50μs, 2Ω
3a	-100V	-150V	1h	90ms	100ms	0.1μs, 50Ω
3b	+75V	+100V	1h	90ms	100ms	0.1μs, 50Ω
4	-6V	-7V	1 pulse			100ms, 0.01Ω
5b ⁽²⁾	+65V	+87V	1 pulse			400ms, 2Ω

1. The above test levels must be considered referred to $V_{CC} = 13.5\text{ V}$ except for pulse 5b.
2. Valid in case of external load dump clamp: 40V maximum referred to ground.

Table 16. Electrical transient requirements (part 2)

ISO 7637-2: 2004(E) Test pulse	Test level results ⁽¹⁾	
	III	IV
1	C	C
2a	C	C
3a	C	C
3b	C	C
4	C	C
5b ⁽²⁾	C	C

1. The above test levels must be considered referred to $V_{CC} = 13.5\text{ V}$ except for pulse 5b.
2. Valid in case of external load dump clamp: 40V maximum referred to ground.

Table 17. Electrical transient requirements (part 3)

Class	Contents
C	All functions of the device are performed as designed after exposure to disturbance.
E	One or more functions of the device are not performed as designed after exposure to disturbance and cannot be returned to proper operation without replacing the device.

2.4 Waveforms

Figure 9. Waveforms in full-bridge operation

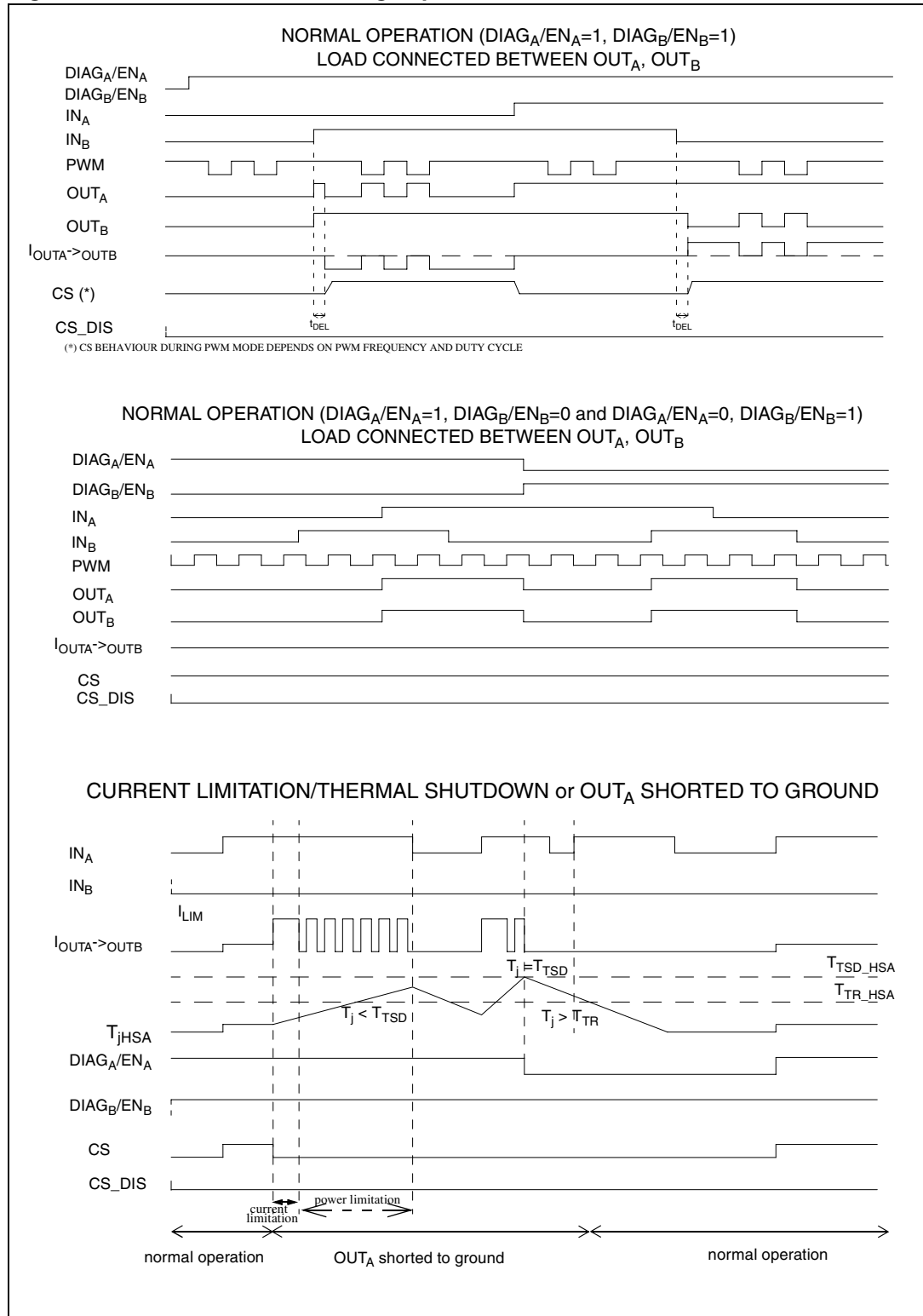
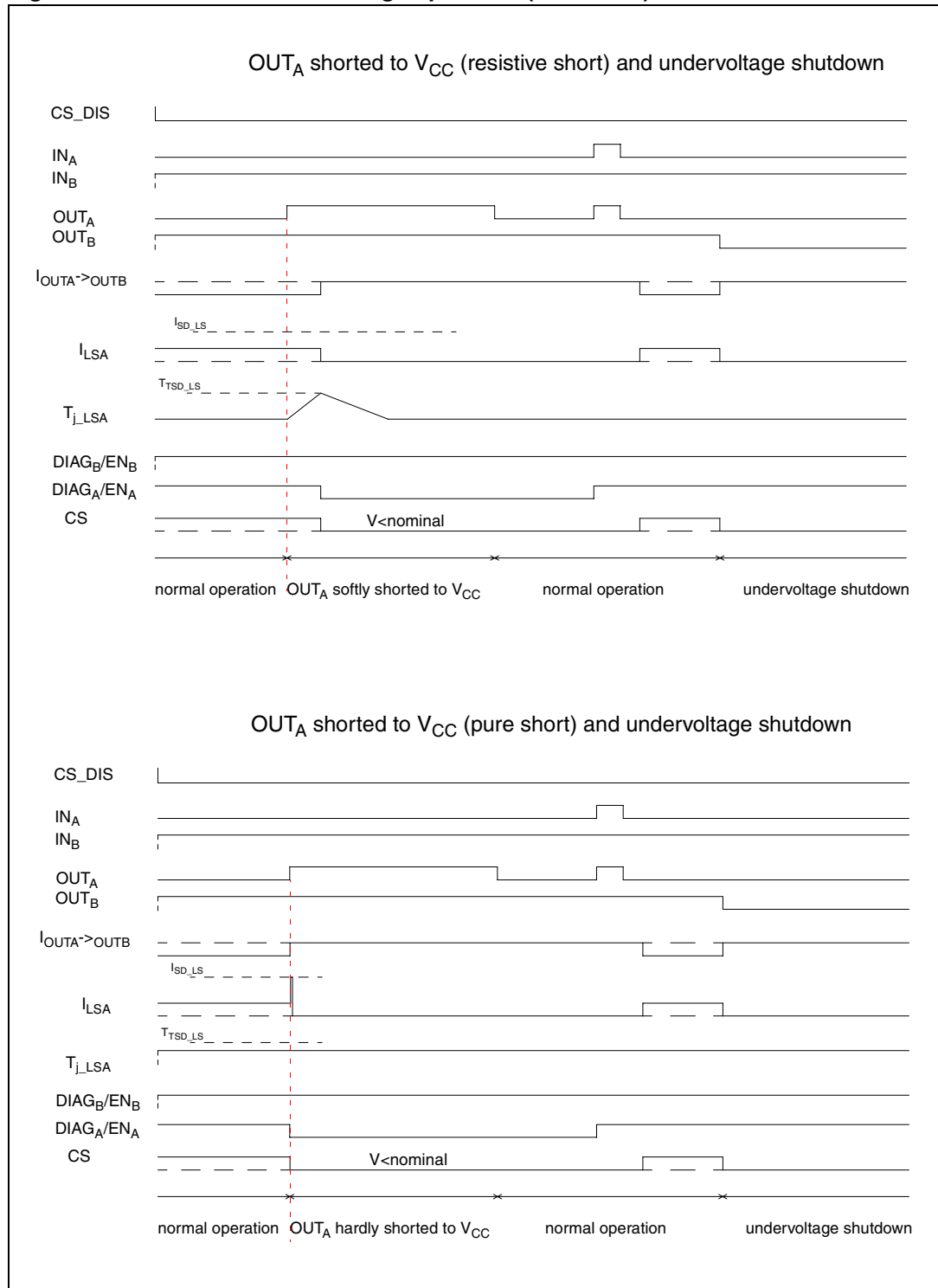

Figure 10. Waveforms in full-bridge operation (continued)



3 Application information

In normal operating conditions the DIAG_X/EN_X pin is considered as an input pin by the device. This pin must be externally pulled high.

PWM pin usage: In all cases, a “0” on the PWM pin turns off both LS_A and LS_B switches. When PWM rises back to “1”, LS_A or LS_B turn on again depending on the input pin state.

Figure 11. Typical application circuit for DC to 20 kHz PWM operation short circuit protection

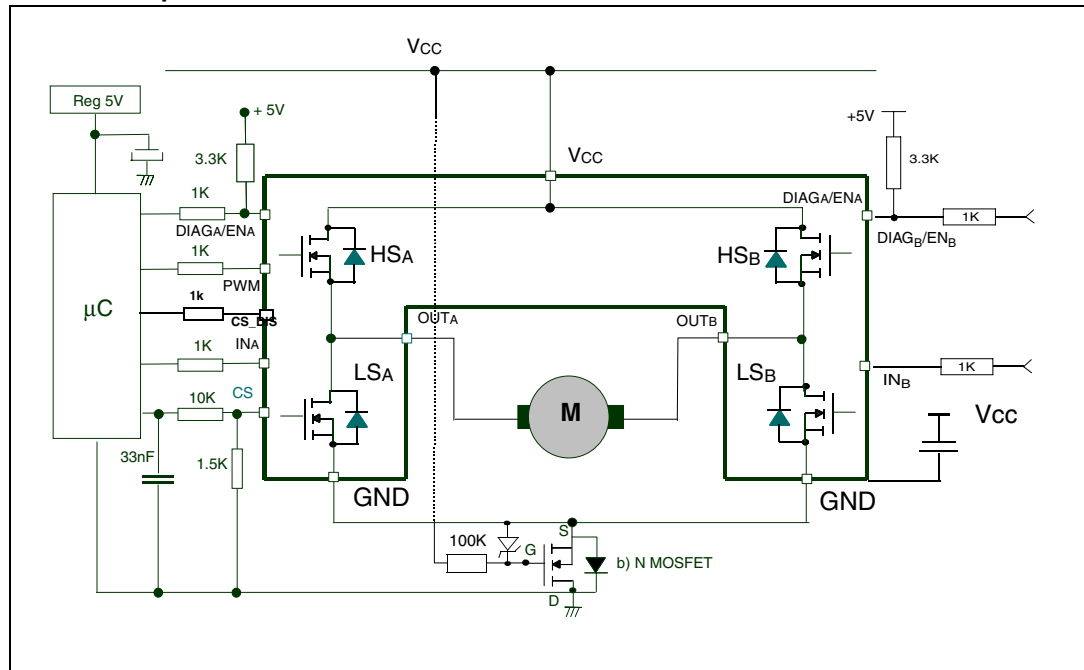

Note: The value of the blocking capacitor (C) depends on the application conditions and defines voltage and current ripple on supply line at PWM operation. Stored energy of the motor inductance may fly back into the blocking capacitor, if the bridge driver goes into 3-state. This causes a hazardous overvoltage if the capacitor is not big enough. As basic orientation, 500 µF per 10 A load current is recommended.

In case of a fault condition the DIAG_X/EN_X pin is considered as an output pin by the device.

The fault conditions are:

- Overtemperature on one or both high-sides
- Short to battery condition on the output (overcurrent detection on the low-side Power MOSFET)

Possible origins of fault conditions may be:

OUT_A is shorted to ground → overtemperature detection on high-side A

OUT_A is shorted to V_{CC} → low-side Power MOSFET overcurrent detection

When a fault condition is detected, the user can identify which power element is in fault by monitoring the IN_A, IN_B, DIAG_A/EN_A and DIAG_B/EN_B pins.

In any case, when a fault is detected, the faulty leg of the bridge is latched off. To turn on the respective output (OUT_x) again, the input signal must rise from low to high level.

Figure 12. Behavior in fault condition (how a fault can be cleared)

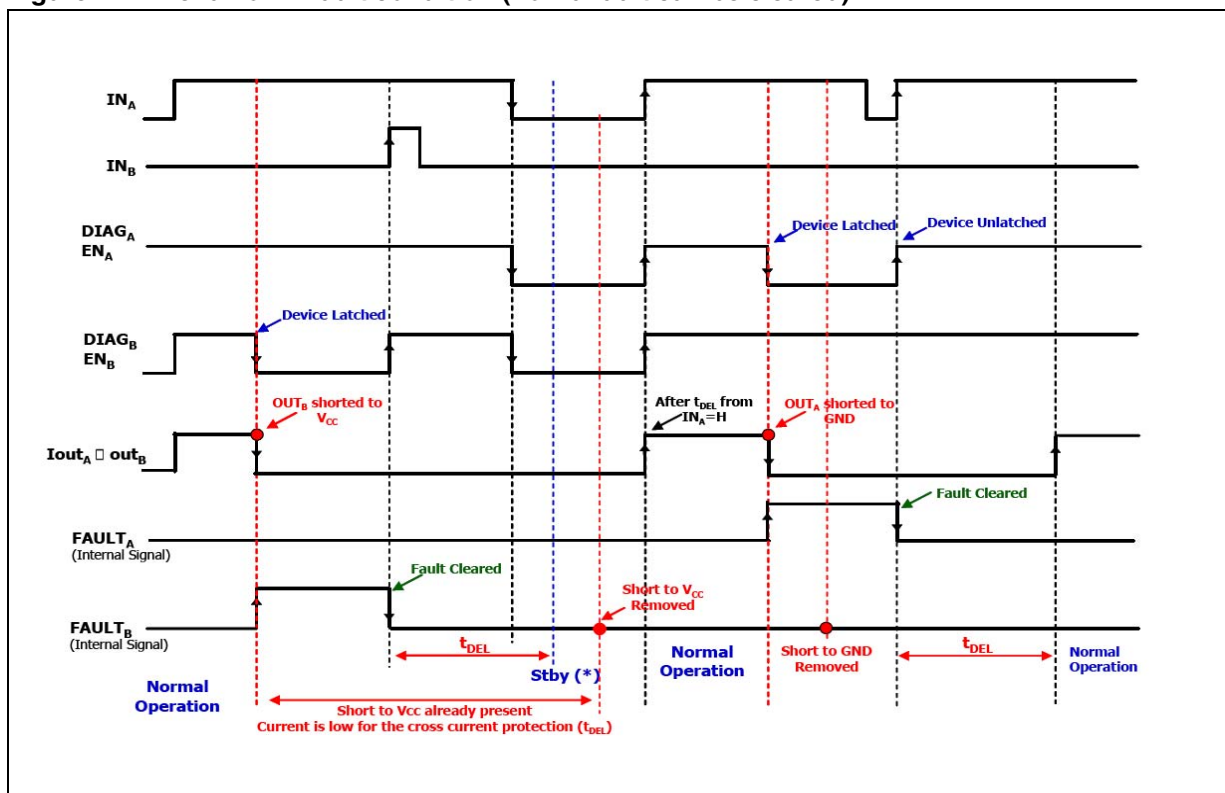

Note: In case of the fault condition is not removed, the procedure for unlatching and sending the device in Stby mode is:

- Clear the fault in the device (toggle: IN_A if EN_A = 0 or IN_B if EN_B = 0)
- Pull low all inputs, PWM and Diag/EN pins within t_{DEL}.

If the Diag/En pins are already low, PWM = 0, the fault can be cleared simply toggling the input. The device enters in stby mode as soon as the fault is cleared.

3.1 Reverse battery protection

Three possible solutions can be considered:

- A Schottky diode D connected to V_{CC} pin
- An N-channel MOSFET connected to the GND pin (see [Figure 11: Typical application circuit for DC to 20 kHz PWM operation short circuit protection](#))
- A P-channel MOSFET connected to the V_{CC} pin

The device sustains no more than -15 A in reverse battery conditions because of the two Body diodes of the Power MOSFETs. Additionally, in reverse battery condition the I/Os of VNH5180A-E is pulled down to the V_{CC} line (approximately -1.5 V).

Series resistor must be inserted to limit the current sunk from the microcontroller I/Os. If I_{Rmax} is the maximum target reverse current through microcontroller I/Os, series resistor is:

$$R = \frac{V_{IOs} - V_{CC}}{I_{Rmax}}$$

Figure 13. Half-bridge configuration

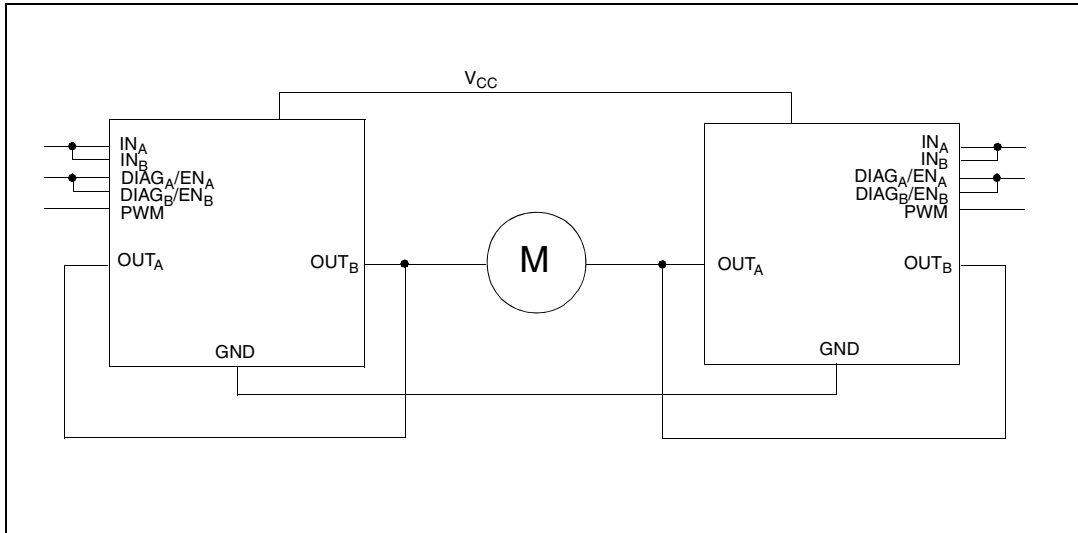

Note: The VNH5180A-E can be used as a high power half-bridge driver achieving an On resistance per leg of 90 mΩ.

Figure 14. Multi-motors configuration

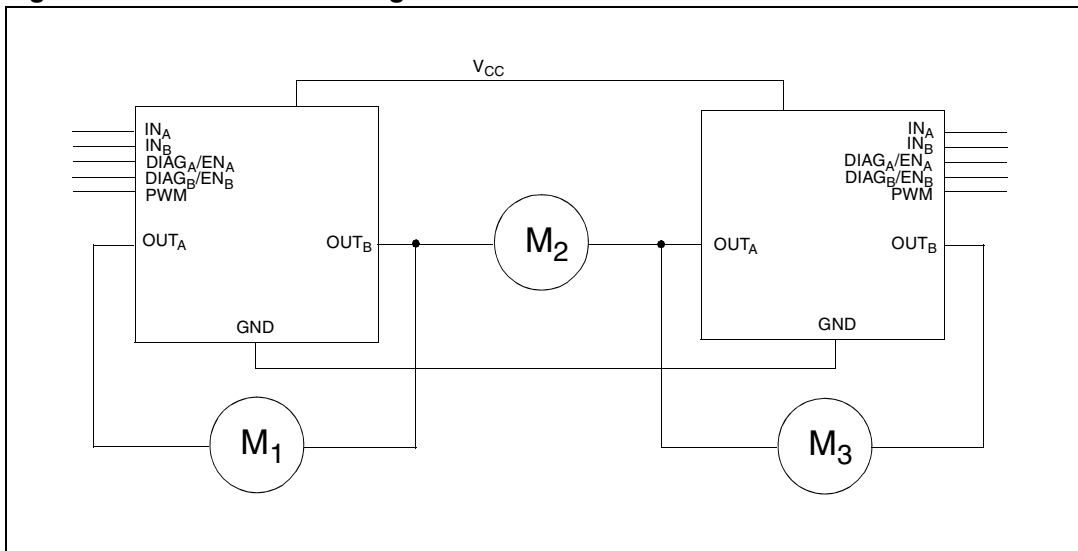

Note: The VNH5180A-E can easily be designed in multi-motors driving applications such as seat positioning systems where only one motor must be driven at a time. $DIAG_X/EN_X$ pins allow to put unused half-bridges in high impedance.

4 Package and PCB thermal data

4.1 PowerSSO-36 thermal data

Figure 15. PowerSSO-36™ PC board

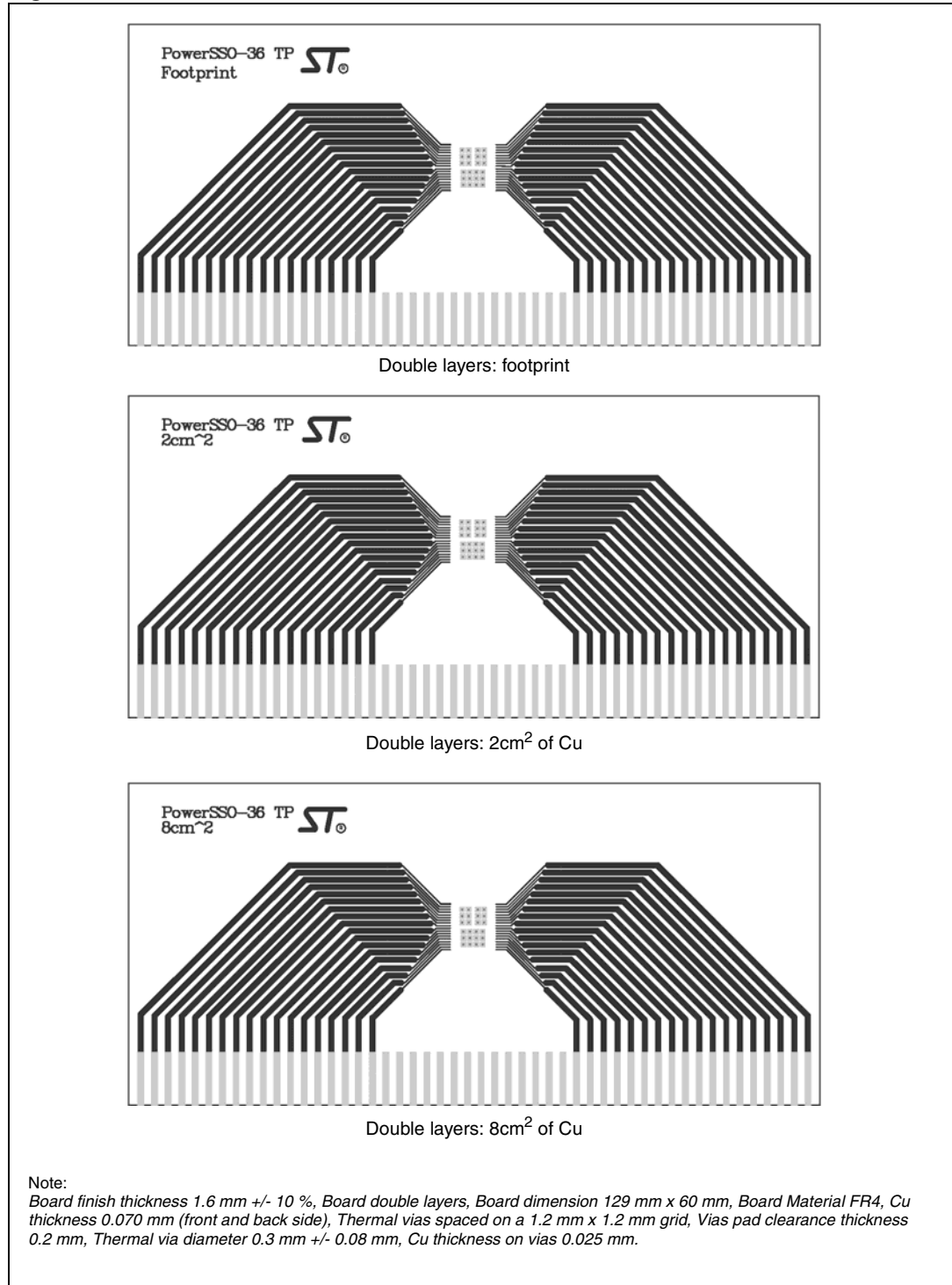

Figure 16. Chipset configuration

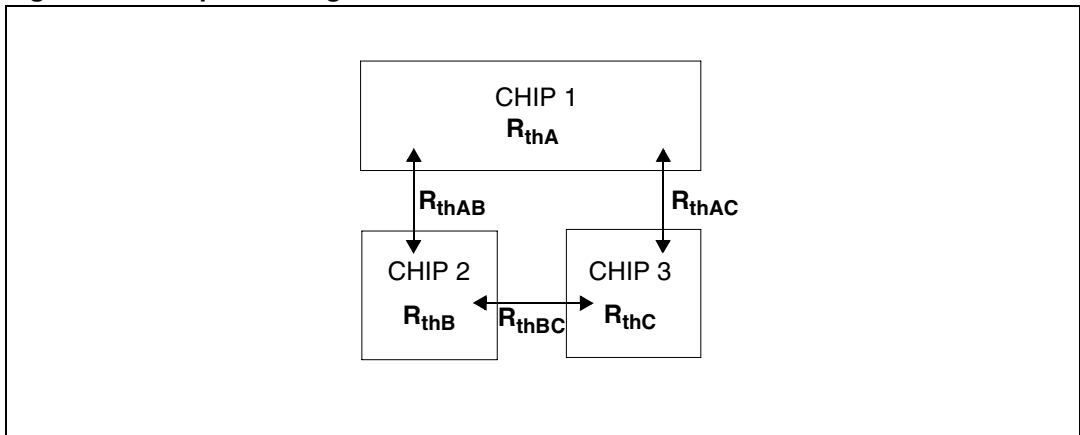
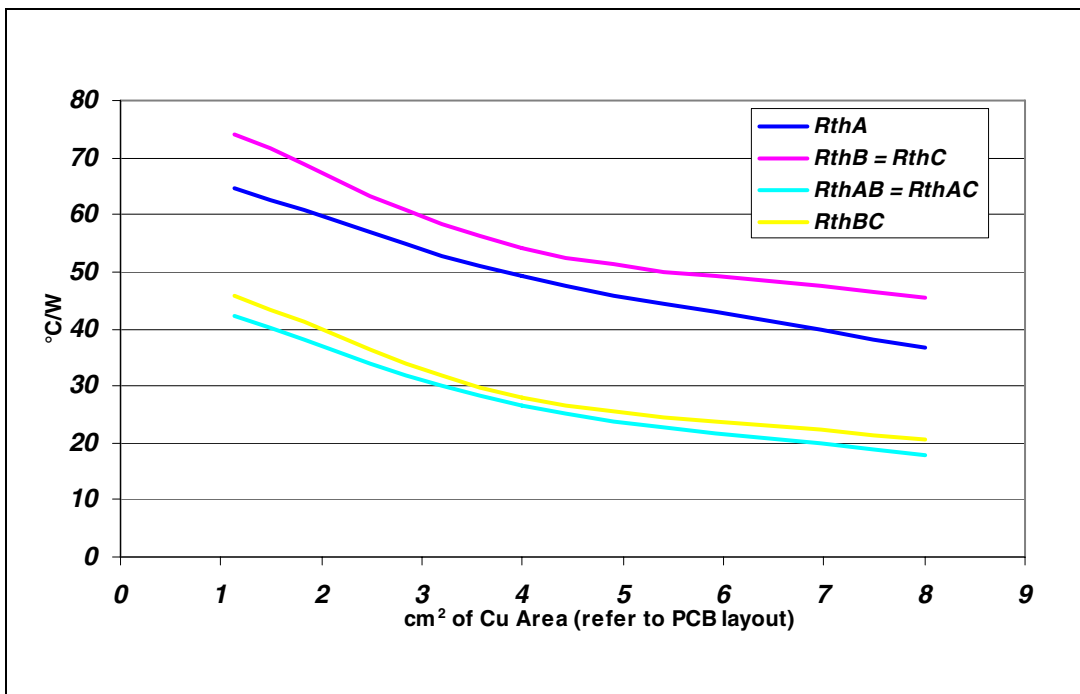

Figure 17. Auto and mutual $R_{thj-amb}$ vs PCB copper area in open box free air condition



4.1.1 Thermal calculation in clockwise and anti-clockwise operation in steady-state mode

Table 18. Thermal calculation in clockwise and anti-clockwise operation in steady-state mode

HS_A	HS_B	LS_A	LS_B	T_{jHSAB}	T_{jLSA}	T_{jLSB}
ON	OFF	OFF	ON	$P_{dHSA} \times R_{thHS} + P_{dLSB} \times R_{thHSL} + T_{amb}$	$P_{dHSA} \times R_{thHSL} + P_{dLSB} \times R_{thLSL} + T_{amb}$	$P_{dHSA} \times R_{thHSL} + P_{dLSB} \times R_{thLS} + T_{amb}$
OFF	ON	ON	OFF	$P_{dHSB} \times R_{thHS} + P_{dLSA} \times R_{thHSL} + T_{amb}$	$P_{dHSB} \times R_{thHSL} + P_{dLSA} \times R_{thLS} + T_{amb}$	$P_{dHSB} \times R_{thHSL} + P_{dLSA} \times R_{thLSL} + T_{amb}$

4.1.2 Thermal calculation in transient mode

$$T_{hs} = P_{dhs} \cdot Z_{hs} + Z_{hsIs} \cdot (P_{dIsA} + P_{dIsB}) + T_{amb}$$

$$T_{IsA} = P_{dIsA} \cdot Z_{Is} + P_{dhs} \cdot Z_{hsIs} + P_{dIsB} \cdot Z_{hsIs} + T_{amb}$$

$$T_{IsB} = P_{dIsB} \cdot Z_{Is} + P_{dhs} \cdot Z_{hsIs} + P_{dIsA} \cdot Z_{hsIs} + T_{amb}$$

Figure 18. Detailed chipset configuration

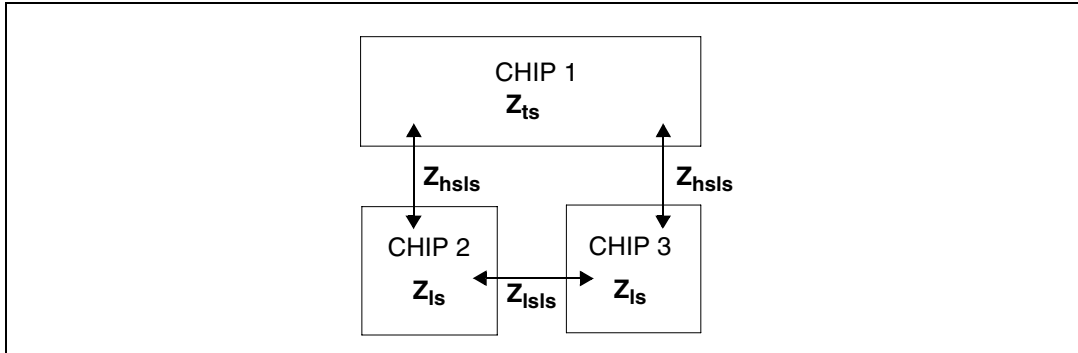

Equation 1: pulse calculation formula

$$Z_{TH\delta} = R_{TH} \cdot \delta + Z_{THtp}(1 - \delta)$$

where

$$\delta = t_p/T$$

Figure 19. PowerSSO-36 HSD thermal impedance junction ambient single pulse

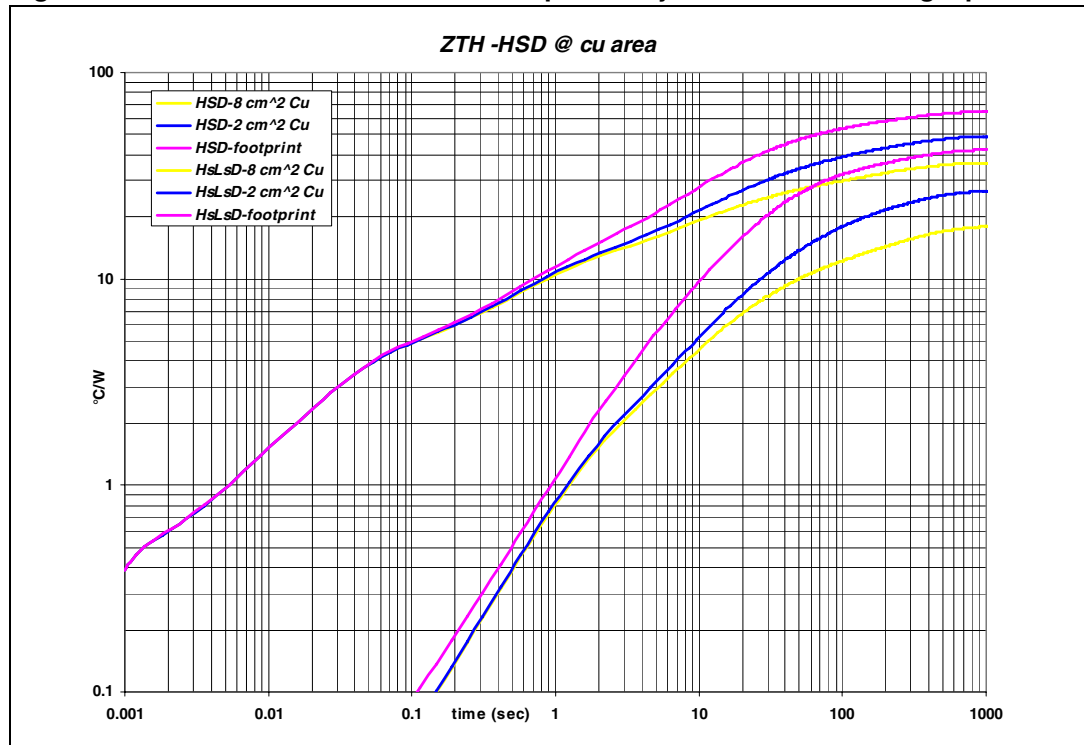

Figure 20. PowerSSO-36 LSD thermal impedance junction ambient single pulse

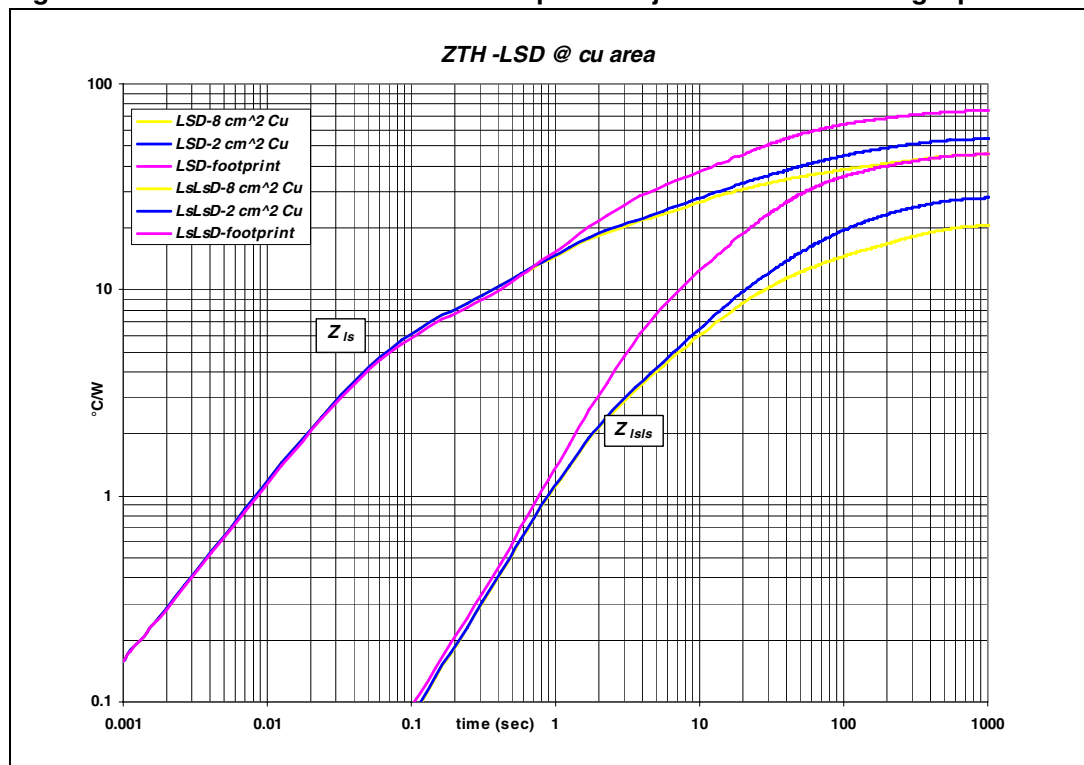

Figure 21. Thermal fitting model of an H-bridge in PowerSSO-36

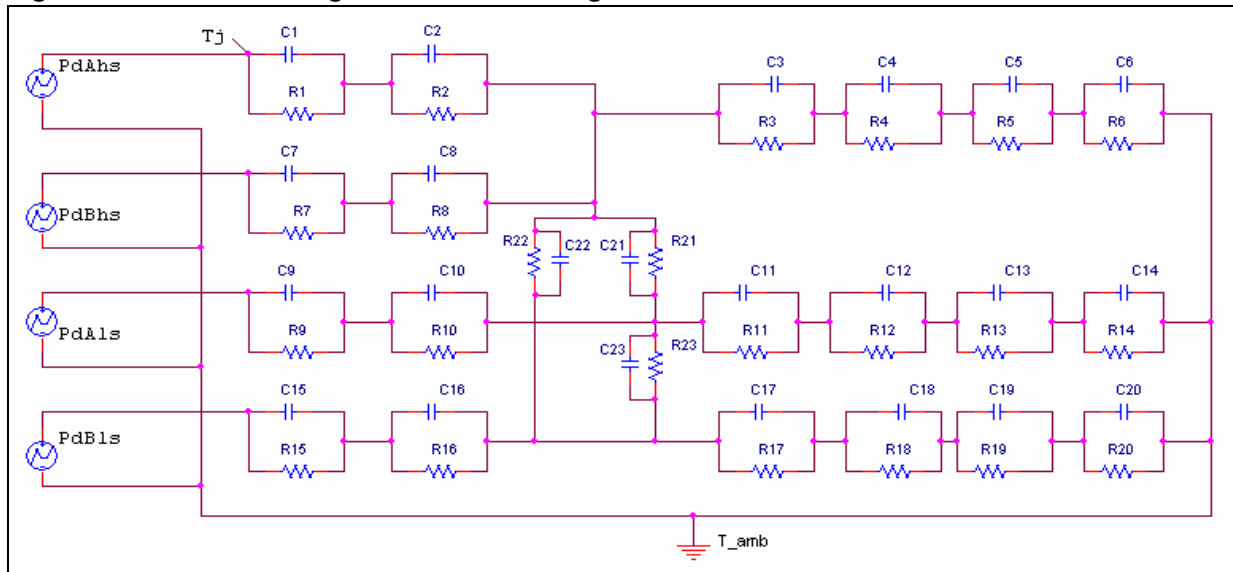

Table 19. Thermal parameters⁽¹⁾

Area/island (cm ²)	Footprint	2	8
R1 = R7 (°C/W)	0.4		
R2 = R8 (°C/W)	3.5		
R3 (°C/W)	8		
R4 (°C/W)	30	16	11
R5 (°C/W)	40	30	14
R6 (°C/W)	36	34	21
R9 = R15 (°C/W)	0.1		
R10 = R16 (°C/W)	5.2		
R11 = R17 (°C/W)	32	14	14
R12 = R18 (°C/W)	49	21	21
R13 = R19 (°C/W)	52	36	24
R14 = R20 (°C/W)	50	40	33
R21 = R22 = R23 (°C/W)	80	77	75
C1 = C7 = C9 = C15 (W.s/°C)	0.0005		
C2 = C8 (W.s/°C)	0.008		
C3 (W.s/°C)	0.09		
C4 (W.s/°C)	0.5	0.8	0.8
C5 (W.s/°C)	0.8	1.4	2
C6 (W.s/°C)	7	8	10
C10 = C16 (W.s/°C)	0.009		
C11 = C17 (W.s/°C)	0.09	0.07	0.07
C12 = C18 (W.s/°C)	0.45	0.45	0.45
C13 = C19 (W.s/°C)	0.8	1.2	1.4
C14 = C20 (W.s/°C)	4	5	8
C21 = C22 = C23 (W.s/°C)	0.005	0.003	0.003

1. The blank space means that the value is the same as the previous one.

5 Package and packing information

5.1 ECOPACK®

In order to meet environmental requirements, ST offers these devices in different grades of ECOPACK® packages, depending on their level of environmental compliance. ECOPACK® specifications, grade definitions and product status are available at: www.st.com.

ECOPACK® is an ST trademark.

5.2 PowerSSO-36 TP package information

Figure 22. PowerSSO-36 TP package dimensions

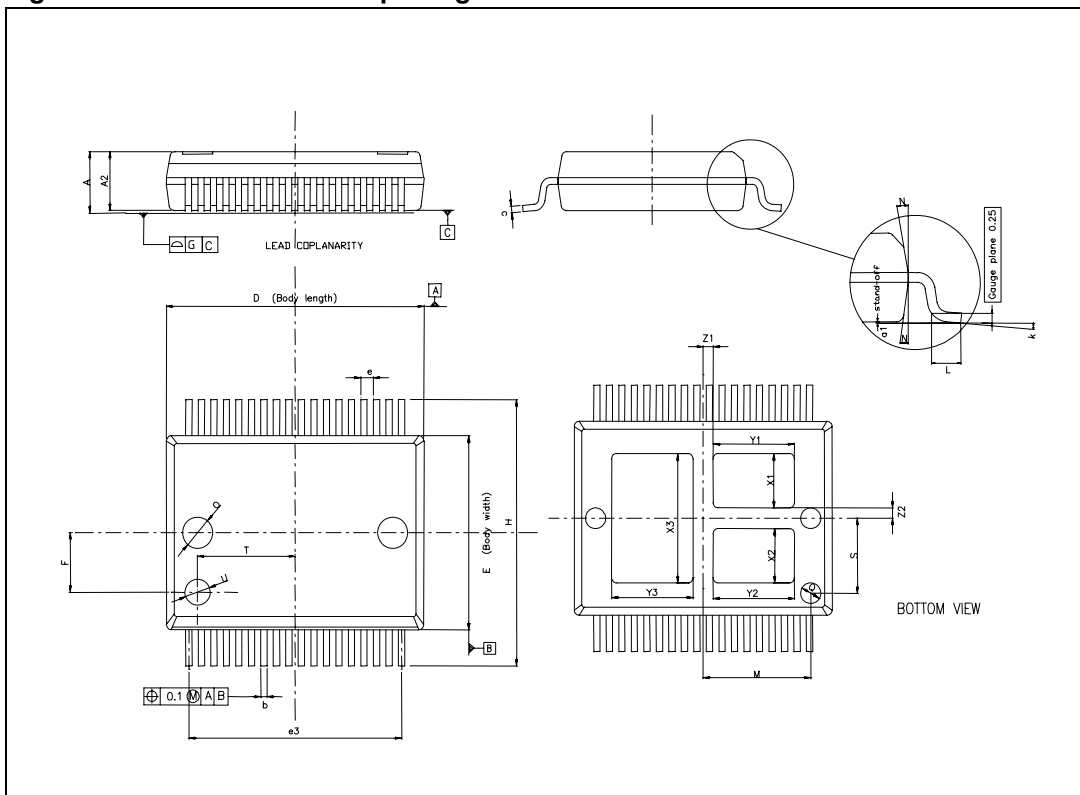

Table 20. PowerSSO-36 TP mechanical data

Symbol	Millimeters		
	Min.	Typ.	Max.
A	2.15	-	2.47
A2	2.15	-	2.40
a1	0	-	0.1
b	0.18	-	0.36
c	0.23	-	0.32
D	10.10	-	10.50
E	7.4	-	7.6
e	-	0.5	-
e3	-	8.5	-
F		2.3	
G	-	-	0.1
H	10.1	-	10.5
h	-	-	0.4
k	0 deg		8 deg
L	0.6	-	1
M		4.3	
N	-	-	10 deg
O		1.2	
Q		0.8	
S		2.9	
T		3.65	
U		1.0	
X1	1.85		2.35
Y1	3		3.5
X2	1.85		2.35
Y2	3		3.5
X3	4.7	-	5.2
Y3	3	-	3.5
Z1		0.4	
Z2		0.4	

5.3 PowerSSO-36 TP packing information

Figure 23. PowerSSO-36 TP tube shipment (no suffix)

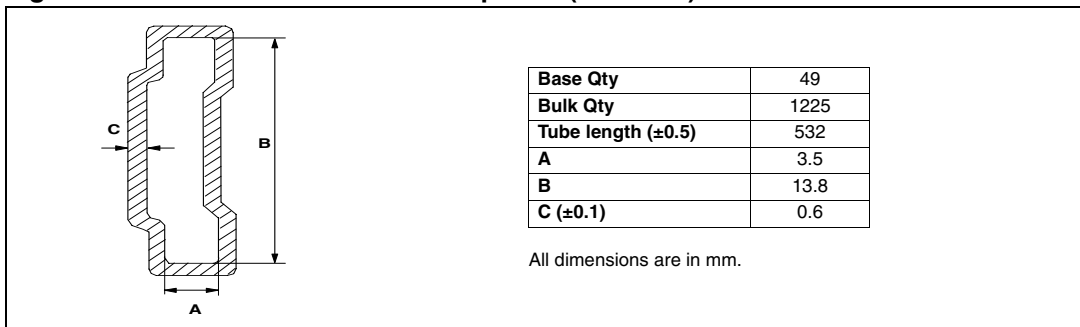
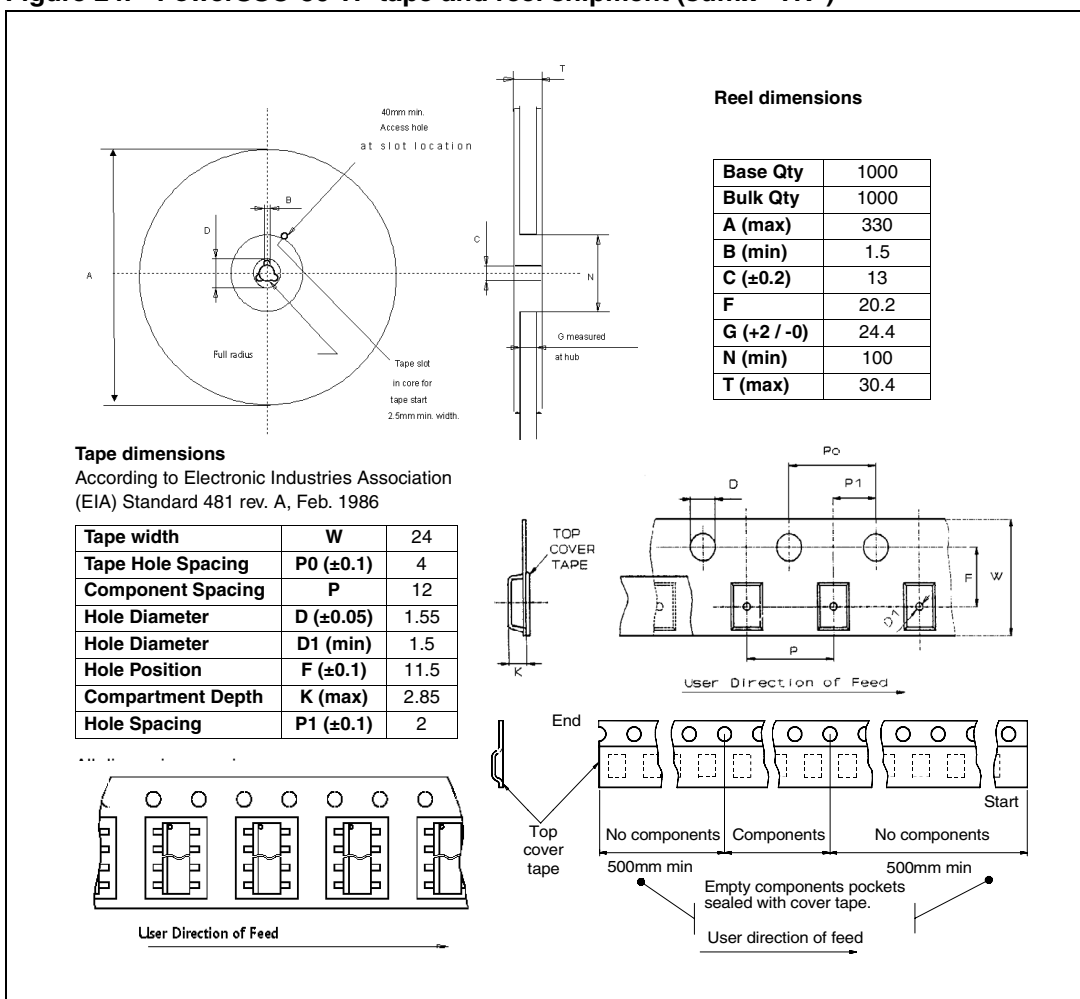

Figure 24. PowerSSO-36 TP tape and reel shipment (suffix "TR")



6 Revision history

Table 21. Document revision history

Date	Revision	Changes
11-Feb-2010	1	Initial release.
28-Sep-2010	2	Updated following tables: <ul style="list-style-type: none"> – Table 7: Thermal data – Table 8: Power section – Table 12: Current sense (9 V < VCC < 18 V)
13-Oct-2010	3	Updated Chapter 3: Application information Updated following tables: <ul style="list-style-type: none"> – Table 18: Thermal calculation in clockwise and anti-clockwise operation in steady-state mode – Table 19: Thermal parameters
20-Oct-2010	4	Changed document status from target specification to definitive datasheet
22-Dec-2011	5	Updated Figure 1: Block diagram Added Table 3: Suggested connections for unused and not connected pins Table 11: Protections and diagnostics: <ul style="list-style-type: none"> – T_{TSD}, T_{TR}, T_{HYST}: added note Updated Figure 9: Waveforms in full-bridge operation and Figure 10: Waveforms in full-bridge operation (continued)

Please Read Carefully:

Information in this document is provided solely in connection with ST products. STMicroelectronics NV and its subsidiaries ("ST") reserve the right to make changes, corrections, modifications or improvements, to this document, and the products and services described herein at any time, without notice.

All ST products are sold pursuant to ST's terms and conditions of sale.

Purchasers are solely responsible for the choice, selection and use of the ST products and services described herein, and ST assumes no liability whatsoever relating to the choice, selection or use of the ST products and services described herein.

No license, express or implied, by estoppel or otherwise, to any intellectual property rights is granted under this document. If any part of this document refers to any third party products or services it shall not be deemed a license grant by ST for the use of such third party products or services, or any intellectual property contained therein or considered as a warranty covering the use in any manner whatsoever of such third party products or services or any intellectual property contained therein.

UNLESS OTHERWISE SET FORTH IN ST'S TERMS AND CONDITIONS OF SALE ST DISCLAIMS ANY EXPRESS OR IMPLIED WARRANTY WITH RESPECT TO THE USE AND/OR SALE OF ST PRODUCTS INCLUDING WITHOUT LIMITATION IMPLIED WARRANTIES OF MERCHANTABILITY, FITNESS FOR A PARTICULAR PURPOSE (AND THEIR EQUIVALENTS UNDER THE LAWS OF ANY JURISDICTION), OR INFRINGEMENT OF ANY PATENT, COPYRIGHT OR OTHER INTELLECTUAL PROPERTY RIGHT.

UNLESS EXPRESSLY APPROVED IN WRITING BY TWO AUTHORIZED ST REPRESENTATIVES, ST PRODUCTS ARE NOT RECOMMENDED, AUTHORIZED OR WARRANTED FOR USE IN MILITARY, AIR CRAFT, SPACE, LIFE SAVING, OR LIFE SUSTAINING APPLICATIONS, NOR IN PRODUCTS OR SYSTEMS WHERE FAILURE OR MALFUNCTION MAY RESULT IN PERSONAL INJURY, DEATH, OR SEVERE PROPERTY OR ENVIRONMENTAL DAMAGE. ST PRODUCTS WHICH ARE NOT SPECIFIED AS "AUTOMOTIVE GRADE" MAY ONLY BE USED IN AUTOMOTIVE APPLICATIONS AT USER'S OWN RISK.

Resale of ST products with provisions different from the statements and/or technical features set forth in this document shall immediately void any warranty granted by ST for the ST product or service described herein and shall not create or extend in any manner whatsoever, any liability of ST.

ST and the ST logo are trademarks or registered trademarks of ST in various countries.

Information in this document supersedes and replaces all information previously supplied.

The ST logo is a registered trademark of STMicroelectronics. All other names are the property of their respective owners.

© 2011 STMicroelectronics - All rights reserved

STMicroelectronics group of companies

Australia - Belgium - Brazil - Canada - China - Czech Republic - Finland - France - Germany - Hong Kong - India - Israel - Italy - Japan - Malaysia - Malta - Morocco - Philippines - Singapore - Spain - Sweden - Switzerland - United Kingdom - United States of America

www.st.com

