



VND5T100AJ-E

Double channel high-side driver with analog current sense for 24 V automotive applications

Features

Max transient supply voltage	V_{CC}	58 V
Operating voltage range	V_{CC}	8 to 36 V
Typ on-state resistance (per ch.)	R_{ON}	100 m Ω
Current limitation (typ)	I_{LIM}	22 A
Off-state supply current	I_S	2 μ A ⁽¹⁾

1. Typical value with all loads connected.

- General
 - Very low standby current
 - 3.0 V CMOS compatible input
 - Optimized electromagnetic emission
 - Very low electromagnetic susceptibility
 - Compliance with European directive 2002/95/EC
 - Fault reset standby pin (FR_Stby)
- Diagnostic functions
 - Proportional load current sense
 - High current sense precision for wide range currents
 - Off-state open-load detection
 - Output short to V_{CC} detection
 - Overload and short to ground latch-off
 - Thermal shutdown latch-off
 - Very low current sense leakage
- Protection
 - Undervoltage shutdown
 - Overvoltage clamp
 - Load current limitation
 - Self limiting of fast thermal transients
 - Protection against loss of ground and loss of V_{CC}
 - Thermal shutdown
 - Electrostatic discharge protection



Application

All types of resistive, inductive and capacitive loads

Description

The VND5T100AJ-E is a monolithic device made using STMicroelectronics™ VIPower™ technology, intended for driving resistive or inductive loads with one side connected to ground. Active V_{CC} pin voltage clamp protects the device against low energy spikes.

This device integrates an analog current sense which delivers a current proportional to the load current.

Fault conditions such as overload, overtemperature or short to V_{CC} are reported via the current sense pin.

Output current limitation protects the device in overload condition. The device latches off in case of overload or thermal shutdown.

The device is reset by a low level pass on the fault reset standby pin.

A permanent low level on the inputs and fault reset standby pin disables all outputs and sets the device in standby mode.

Contents

1	Block diagram and pin description	5
2	Electrical specifications	7
2.1	Absolute maximum ratings	7
2.2	Thermal data	8
2.3	Electrical characteristics	9
2.4	Electrical characteristics curves	19
3	Application information	21
3.1	GND protection network against reverse battery	21
3.1.1	Solution 1: resistor in the ground line (RGND only)	21
3.1.2	Solution 2: diode (DGND) in the ground line	22
3.2	Load dump protection	22
3.3	MCU I/Os protection	22
3.4	Maximum demagnetization energy ($V_{CC} = 24\text{ V}$)	23
4	Package and PCB thermal data	24
4.1	PowerSSO-12 thermal data	24
5	Package and packing information	27
5.1	ECOPACK®	27
5.2	PowerSSO-12 mechanical data	27
5.3	Packing information	29
6	Order code	30
7	Revision history	31

List of tables

Table 1.	Pin function	5
Table 2.	Suggested connections for unused and not connected pins	6
Table 3.	Absolute maximum ratings	7
Table 4.	Thermal data	8
Table 5.	Power section	9
Table 6.	Switching	9
Table 7.	Logic inputs	10
Table 8.	Protections and diagnostics	11
Table 9.	Current sense ($8\text{ V} < V_{CC} < 36\text{ V}$)	12
Table 10.	Open-load detection	13
Table 11.	Truth table	17
Table 12.	Electrical transient requirements (part 1)	18
Table 13.	Electrical transient requirements (part 2)	18
Table 14.	Electrical transient requirements (part 3)	18
Table 15.	Thermal parameters	26
Table 16.	PowerSSO-12 mechanical data	28
Table 17.	Device summary	30
Table 18.	Document revision history	31

List of figures

Figure 1.	Block diagram	5
Figure 2.	Configuration diagram (top view)	6
Figure 3.	Current and voltage conventions	7
Figure 4.	T_{standby} definition	10
Figure 5.	T_{reset} definition	11
Figure 6.	Current sense delay characteristics	13
Figure 7.	Open-load off-state delay timing	14
Figure 8.	Switching characteristics	14
Figure 9.	Output stuck to V_{CC} detection delay time at FRSTBY activation	15
Figure 10.	Delay response time between rising edge of output current and rising edge of current sense	15
Figure 11.	Output voltage drop limitation	16
Figure 12.	Device behavior in overload condition	16
Figure 13.	Off-state output current	19
Figure 14.	High level input current	19
Figure 15.	Input clamp voltage	19
Figure 16.	Input high level voltage	19
Figure 17.	Input low level voltage	19
Figure 18.	Input hysteresis voltage	19
Figure 19.	On-state resistance vs T_{case}	20
Figure 20.	On-state resistance vs V_{CC}	20
Figure 21.	I_{LIMH} vs T_{case}	20
Figure 22.	Turn-on voltage slope	20
Figure 23.	Turn-off voltage slope	20
Figure 24.	Application schematic	21
Figure 25.	Maximum turn-off current versus inductance	23
Figure 26.	PowerSSO-12 PC board	24
Figure 27.	$R_{\text{thj-amb}}$ vs PCB copper area in open box free air condition (one channel ON)	24
Figure 28.	PowerSSO-12 thermal impedance junction ambient single pulse (one channel ON)	25
Figure 29.	Thermal fitting model of a double channel HSD in PowerSSO-12	25
Figure 30.	PowerSSO-12 package dimensions	27
Figure 31.	PowerSSO-12 tube shipment (no suffix)	29
Figure 32.	PowerSSO-12 tape and reel shipment (suffix "TR")	29

1 Block diagram and pin description

Figure 1. Block diagram

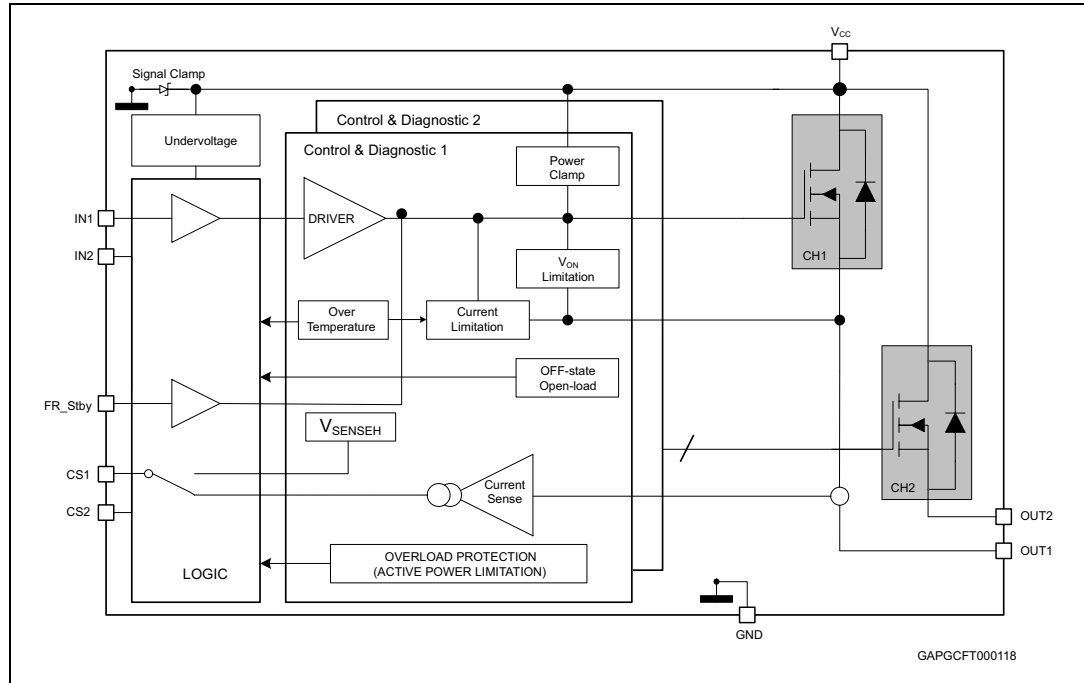

Table 1. Pin function

Name	Function
V _{CC}	Battery connection
OUT _n	Power output
GND	Ground connection
IN _n	Voltage controlled input pin with hysteresis, CMOS compatible. Controls output switch state
CS _n	Analog current sense pin, delivers a current proportional to the load current
FR_Stby	In case of latch-off for OT/overcurrent condition, a low pulse on the FR_Stby pin is needed to reset the channel. The device enters in standby mode if all inputs and the FR_Stby pin are low.

Figure 2. Configuration diagram (top view)

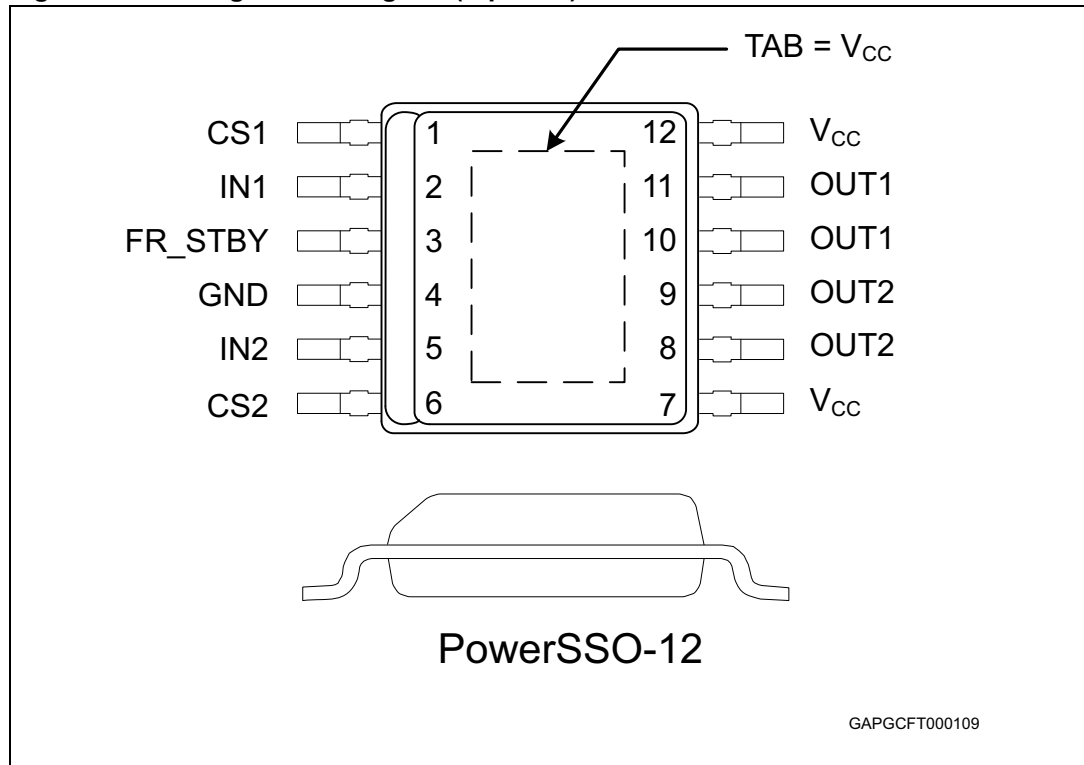
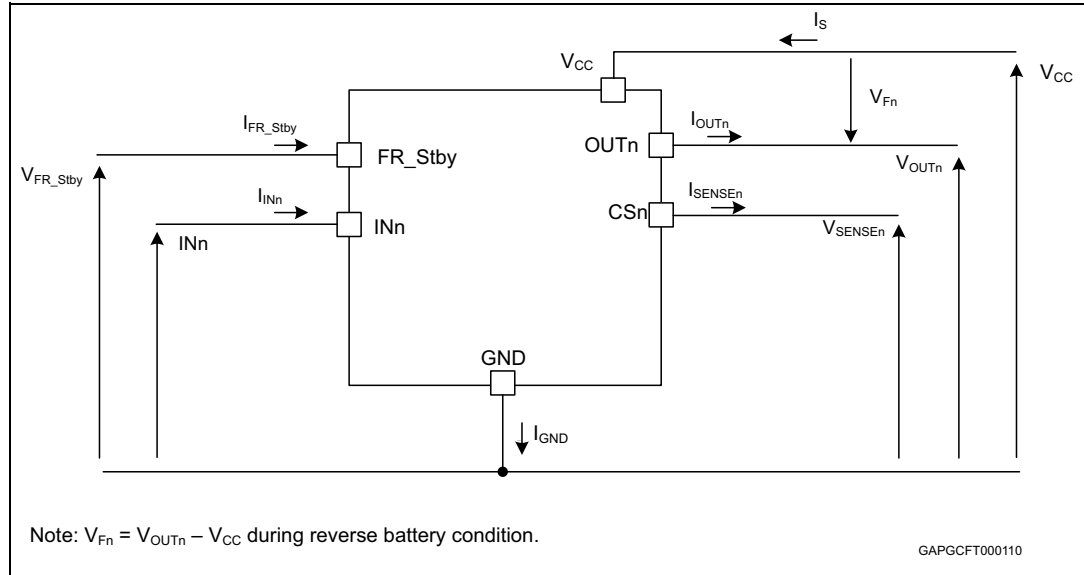

Table 2. Suggested connections for unused and not connected pins

Connection / pin	Current sense	N.C.	Output	Input	FR_Stby
Floating	Not allowed	X	X	X	X
To ground	Through 10 KΩ resistor	X	Not allowed	Through 10 KΩ resistor	Through 10 KΩ resistor

2 Electrical specifications

Figure 3. Current and voltage conventions



2.1 Absolute maximum ratings

Stressing the device above the ratings listed in [Table 3](#) may cause permanent damage to the device. These are stress ratings only and operation of the device at these or any other conditions above those indicated in the operating sections of this specification is not implied. Exposure to the conditions reported in this section for extended periods may affect device reliability. Refer also to the STMicroelectronics™ SURE program and other relevant quality documents.

Table 3. Absolute maximum ratings

Symbol	Parameter	Value	Unit
V_{CC}	DC supply voltage	58	V
$-V_{CC}$	Reverse DC supply voltage	0.3	V
$-I_{GND}$	DC reverse ground pin current	200	mA
I_{OUT}	DC output current	Internally limited	A
$-I_{OUT}$	Reverse DC output current	20	A
I_{IN}	DC input current	-1 to 10	mA
I_{FR_Stby}	Fault reset standby DC input current	-1 to 1.5	mA
$-I_{CSENSE}$	DC reverse CS pin current	200	mA
V_{CSENSE}	Current sense maximum voltage	$V_{CC} - 58$ to $+V_{CC}$	V

Table 3. Absolute maximum ratings (continued)

Symbol	Parameter	Value	Unit
E_{MAX}	Maximum switching energy ($L = 1.9 \text{ mH}$; $V_{bat} = 32 \text{ V}$; $T_{jstart} = 150 \text{ }^\circ\text{C}$; $I_{OUT} = I_{limL} \text{ (Typ)}$)	70	mJ
V_{ESD}	Electrostatic discharge (Human Body Model: $R = 1.5 \text{ K}\Omega$; $C = 100 \text{ pF}$)		
	– INPUT	4000	V
	– CURRENT SENSE	2000	V
	– FR_STBY	4000	V
	– OUTPUT	5000	V
	– V_{CC}	5000	V
V_{ESD}	Charge device model (CDM-AEC-Q100-011)	750	V
T_j	Junction operating temperature	-40 to 150	$^\circ\text{C}$
T_{stg}	Storage temperature	-55 to 150	$^\circ\text{C}$
L_{Smax}	Maximum stray inductance in short circuit $R_L = 300 \text{ m}\Omega$, $V_{bat} = 32 \text{ V}$, $T_{jstart} = 150 \text{ }^\circ\text{C}$, $I_{OUT} = I_{limHmax}$	40	μH

2.2 Thermal data

Table 4. Thermal data

Symbol	Parameter	Maximum value	Unit
$R_{thj-case}$	Thermal resistance junction-case (with one channel ON)	3	$^\circ\text{C/W}$
$R_{thj-amb}$	Thermal resistance junction-ambient	See Figure 27	$^\circ\text{C/W}$

2.3 Electrical characteristics

8 V < V_{CC} < 36 V; -40 °C < T_j < 150 °C, unless otherwise specified.

Table 5. Power section

Symbol	Parameter	Test conditions	Min.	Typ.	Max.	Unit
V _{CC}	Operating supply voltage		8	24	36	V
V _{USD}	Undervoltage shutdown			3.5	5	V
V _{USDhyst}	Undervoltage shutdown hysteresis			0.5		V
R _{ON}	On-state resistance ⁽¹⁾	I _{OUT} = 1.5 A; T _j = 25 °C		100		mΩ
		I _{OUT} = 1.5 A; T _j = 150 °C			200	
V _{clamp}	Clamp voltage	I _S = 20 mA	58	64	70	V
I _S	Supply current	Off-state: V _{CC} = 24 V; T _j = 25 °C; V _{IN} = V _{OUT} = V _{SENSE} = 0 V		2 ⁽²⁾	5 ⁽²⁾	μA
		On-state: V _{CC} = 24 V; V _{IN} = 5 V; I _{OUT} = 0 A		4.2	6	mA
I _{L(off)}	Off-state output current	V _{IN} = V _{OUT} = 0 V; V _{CC} = 24 V; T _j = 25 °C	0	0.01	3	μA
		V _{IN} = V _{OUT} = 0 V; V _{CC} = 24 V; T _j = 125 °C	0		5	
V _F	Output - V _{CC} diode voltage	-I _{OUT} = 1.5 A; T _j = 150 °C			0.7	V

1. For each channel.

2. PowerMos leakage included

Table 6. Switching⁽¹⁾

Symbol	Parameter	Test conditions	Min.	Typ.	Max.	Unit
t _{d(on)}	Turn-on delay time	R _L = 16 Ω		27		μs
t _{d(off)}	Turn-off delay time	R _L = 16 Ω		38		μs
dV _{OUT} /dt _(on)	Turn-on voltage slope	R _L = 16 Ω		1		V/μs
dV _{OUT} /dt _(off)	Turn-off voltage slope	R _L = 16 Ω		0.65		V/μs
W _{ON}	Switching energy losses during t _{won}	R _L = 16 Ω		0.23		mJ
W _{OFF}	Switching energy losses during t _{woff}	R _L = 16 Ω		0.26		mJ

1. Operating conditions: V_{CC} = 24 V; T_j = 25 °C

Table 7. Logic inputs

Symbol	Parameter	Test conditions	Min.	Typ.	Max.	Unit
V_{IL}	Input low level voltage				0.9	V
I_{IL}	Low level input current	$V_{IN} = 0.9\text{ V}$	1			μA
V_{IH}	Input high level voltage		2.1			V
I_{IH}	High level input current	$V_{IN} = 2.1\text{ V}$			10	μA
$V_{I(hyst)}$	Input hysteresis voltage		0.25			V
V_{ICL}	Input clamp voltage	$I_{IN} = 1\text{ mA}$	5.5		7	V
		$I_{IN} = -1\text{ mA}$		-0.7		V
$V_{FR_Stby_L}$	Fault_reset_standby low level voltage				0.9	V
$I_{FR_Stby_L}$	Low level fault_reset_standby current	$V_{FR_Stby} = 0.9\text{ V}$	1			μA
$V_{FR_Stby_H}$	Fault_reset_standby high level voltage		2.1			V
$I_{FR_Stby_H}$	High level fault_reset_standby current	$V_{FR_Stby} = 2.1\text{ V}$			10	μA
$V_{FR_Stby(hyst)}$	Fault_reset_standby hysteresis voltage		0.25			V
$V_{FR_Stby_CL}$	Fault_reset_standby clamp voltage	$I_{FR_Stby} = 15\text{ mA (}t < 10\text{ ms)}$	11		15	V
		$I_{FR_Stby} = -1\text{ mA}$		-0.7		V
t_{reset}	Overload latch-off reset time	See Figure 4	2		24	μs
t_{stby}	Standby delay	See Figure 5	120		1200	μs

Figure 4. $T_{standby}$ definition

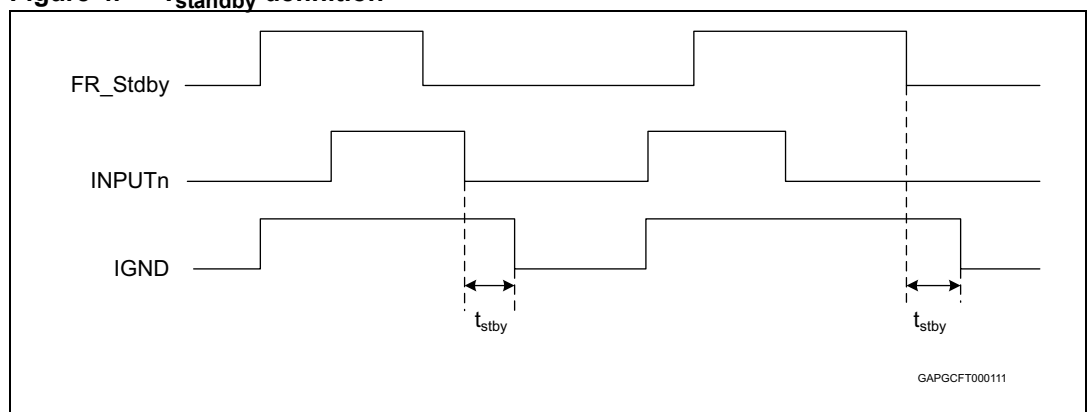

Figure 5. T_{reset} definition

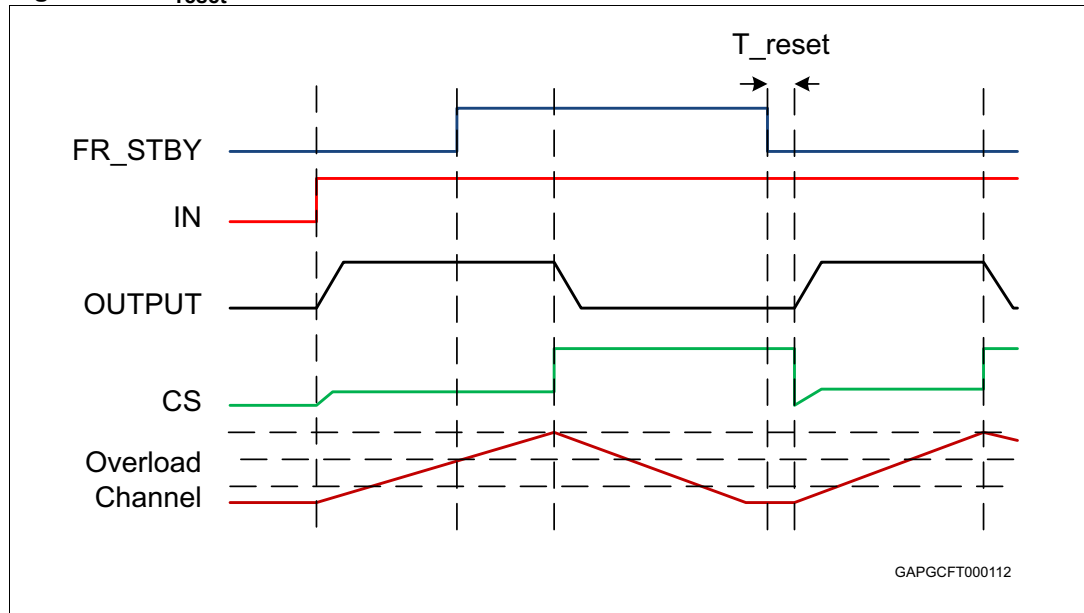

Table 8. Protections and diagnostics

Symbol	Parameter	Test conditions	Min.	Typ.	Max.	Unit
I_{limH}	DC short circuit current	$V_{CC} = 24\text{ V}$	16	22	30	A
		$5\text{ V} < V_{CC} < 36\text{ V}$			30	A
I_{limL}	Short circuit current during thermal cycling	$V_{CC} = 24\text{ V};$ $T_R < T_j < T_{TSD}$		6		A
T_{TSD}	Shutdown temperature		150	175	200	$^{\circ}\text{C}$
T_R	Reset temperature		$T_{RS} + 1$	$T_{RS} + 5$		$^{\circ}\text{C}$
T_{RS}	Thermal reset of status		135			$^{\circ}\text{C}$
T_{HYST}	Thermal hysteresis ($T_{TSD} - T_R$)			7		$^{\circ}\text{C}$
V_{DEMAG}	Turn-off output voltage clamp	$I_{OUT} = 1.5\text{ A}; V_{IN} = 0;$ $L = 6\text{ mH}$	$V_{CC} - 58$	$V_{CC} - 64$	$V_{CC} - 70$	V
V_{ON}	Output voltage drop limitation	$I_{OUT} = 50\text{ mA};$ $T_j = -40\text{ }^{\circ}\text{C} \dots +150\text{ }^{\circ}\text{C}$		25		mV

Table 9. Current sense ($8\text{ V} < V_{CC} < 36\text{ V}$)

Symbol	Parameter	Test conditions	Min.	Typ.	Max.	Unit
K_1	I_{OUT}/I_{SENSE}	$I_{OUT} = 350\text{ mA}$; $V_{SENSE} = 1\text{ V}$; $T_j = -40\text{ }^\circ\text{C} \dots 150\text{ }^\circ\text{C}$ $T_j = 25\text{ }^\circ\text{C} \dots 150\text{ }^\circ\text{C}$	930 1050	1547 1547	2185 2020	
$dK_1/K_1^{(1)}$	Current sense ratio drift	$I_{OUT} = 350\text{ mA}$; $V_{SENSE} = 1\text{ V}$; $T_j = -40\text{ }^\circ\text{C}$ to $150\text{ }^\circ\text{C}$	-15		15	%
K_2	I_{OUT}/I_{SENSE}	$I_{OUT} = 0.8\text{ A}$; $V_{SENSE} = 2\text{ V}$; $T_j = -40\text{ }^\circ\text{C} \dots 150\text{ }^\circ\text{C}$ $T_j = 25\text{ }^\circ\text{C} \dots 150\text{ }^\circ\text{C}$	1225 1310	1528 1528	1835 1745	
$dK_2/K_2^{(1)}$	Current sense ratio drift	$I_{OUT} = 0.8\text{ A}$; $V_{SENSE} = 2\text{ V}$; $T_j = -40\text{ }^\circ\text{C}$ to $150\text{ }^\circ\text{C}$	-12		12	%
K_3	I_{OUT}/I_{SENSE}	$I_{OUT} = 1.5\text{ A}$; $V_{SENSE} = 2\text{ V}$; $T_j = -40\text{ }^\circ\text{C} \dots 150\text{ }^\circ\text{C}$ $T_j = 25\text{ }^\circ\text{C} \dots 150\text{ }^\circ\text{C}$	1340 1405	1525 1525	1715 1655	
$dK_3/K_3^{(1)}$	Current sense ratio drift	$I_{OUT} = 1.5\text{ A}$; $V_{SENSE} = 2\text{ V}$; $T_j = -40\text{ }^\circ\text{C}$ to $150\text{ }^\circ\text{C}$	-8		8	%
K_4	I_{OUT}/I_{SENSE}	$I_{OUT} = 6\text{ A}$; $V_{SENSE} = 4\text{ V}$; $T_j = -40\text{ }^\circ\text{C} \dots 150\text{ }^\circ\text{C}$ $T_j = 25\text{ }^\circ\text{C} \dots 150\text{ }^\circ\text{C}$	1450 1475	1522 1522	1600 1560	
$dK_4/K_4^{(1)}$	Current sense ratio drift	$I_{OUT} = 6\text{ A}$; $V_{SENSE} = 4\text{ V}$; $T_j = -40\text{ }^\circ\text{C}$ to $150\text{ }^\circ\text{C}$	-5		5	%
I_{SENSE0}	Analog sense leakage current	$I_{OUT} = 0\text{ A}$; $V_{SENSE} = 0\text{ V}$; $V_{IN} = 0\text{ V}$; $T_j = -40\text{ }^\circ\text{C} \dots 150\text{ }^\circ\text{C}$ $V_{IN} = 5\text{ V}$; $T_j = -40\text{ }^\circ\text{C} \dots 150\text{ }^\circ\text{C}$	0 0		1 2	μA μA
V_{SENSE}	Max analog sense output voltage	$I_{OUT} = 6\text{ A}$; $R_{SENSE} = 3.9\text{ K}\Omega$	5			V
V_{SENSEH}	Analog sense output voltage in fault condition ⁽²⁾	$V_{CC} = 24\text{ V}$; $R_{SENSE} = 3.9\text{ K}\Omega$	7.5	8.5	9.5	V
I_{SENSEH}	Analog sense output current in fault condition ⁽²⁾	$V_{CC} = 24\text{ V}$; $V_{SENSE} = 5\text{ V}$	4.9	9	12	mA
$t_{DSENSE2H}$	Delay response time from rising edge of INPUT pin	$V_{SENSE} < 4\text{ V}$, $0.07\text{ A} < I_{OUT} < 6\text{ A}$ $I_{SENSE} = 90\%$ of $I_{SENSE\text{ max}}$ (see Figure 6)		100	200	μs

Table 9. Current sense (8 V < V_{CC} < 36 V) (continued)

Symbol	Parameter	Test conditions	Min.	Typ.	Max.	Unit
$\Delta t_{\text{DSENSE2H}}$	Delay response time between rising edge of output current and rising edge of current sense	$V_{\text{SENSE}} < 4 \text{ V}$, $I_{\text{SENSE}} = 90 \% \text{ of } I_{\text{SENSEMAX}}$, $I_{\text{OUT}} = 90 \% \text{ of } I_{\text{OUTMAX}}$ $I_{\text{OUTMAX}} = 1.5 \text{ A}$ (see Figure 11)			150	μs
t_{DSENSE2L}	Delay response time from falling edge of INPUT pin	$V_{\text{SENSE}} < 4 \text{ V}$, $0.07 \text{ A} < I_{\text{OUT}} < 6 \text{ A}$ $I_{\text{SENSE}} = 10 \% \text{ of } I_{\text{SENSE max}}$ (see Figure 6)		5	20	μs

1. Parameter guaranteed by design; it is not tested.
2. Fault condition includes: power limitation, overtemperature and open-load in OFF-state condition.

Table 10. Open-load detection

Symbol	Parameter	Test conditions	Min.	Typ.	Max.	Unit
V_{OL}	Open-load off-state voltage detection threshold	$V_{\text{IN}} = 0 \text{ V}$; $8 \text{ V} < V_{\text{CC}} < 36 \text{ V}$; $F_{\text{R_STBY}} = 5 \text{ V}$	2		4	V
t_{DSTKON}	Output short circuit to V _{CC} detection delay at turn off	See Figure 6 ; $F_{\text{R_STBY}} = 5 \text{ V}$	180		1800	μs
$t_{\text{DFRSTK_ON}}$	Output short circuit to V _{CC} detection delay at FRSTBY activation	See Figure 9 ; Input _{1,2} = low			50	μs
$I_{\text{L(off2)}}$	Off-state output current at V _{OUT} = 4V	$V_{\text{IN}} = 0 \text{ V}$; $V_{\text{SENSE}} = 0 \text{ V}$; V_{OUT} rising from 0 V to 4 V; $F_{\text{R_STBY}} = 5 \text{ V}$	-120		0	μA
$t_{\text{d_vol}}$	Delay response from output rising edge to V _{SENSE} rising edge in open-load	$V_{\text{OUT}} = 4 \text{ V}$; $V_{\text{IN}} = 0 \text{ V}$ $V_{\text{SENSE}} = 90 \% \text{ of } V_{\text{SENSEH}}$ $R_{\text{SENSE}} = 3.9 \text{ K}\Omega$; $F_{\text{R_STBY}} = 5 \text{ V}$			20	μs

Figure 6. Current sense delay characteristics

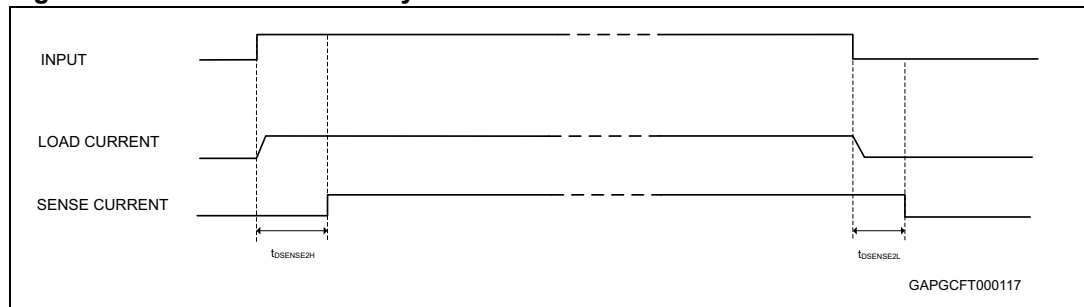

Figure 7. Open-load off-state delay timing

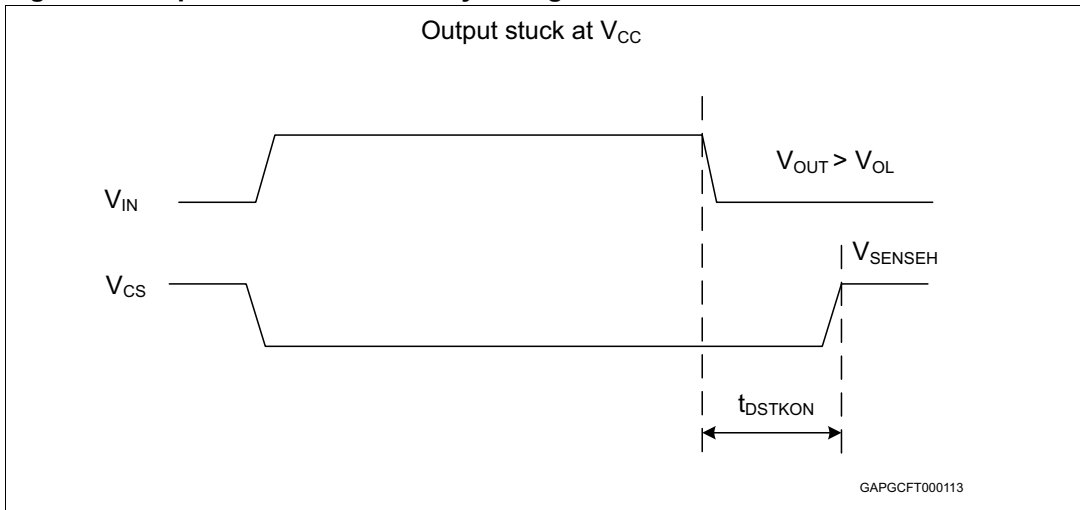

Figure 8. Switching characteristics

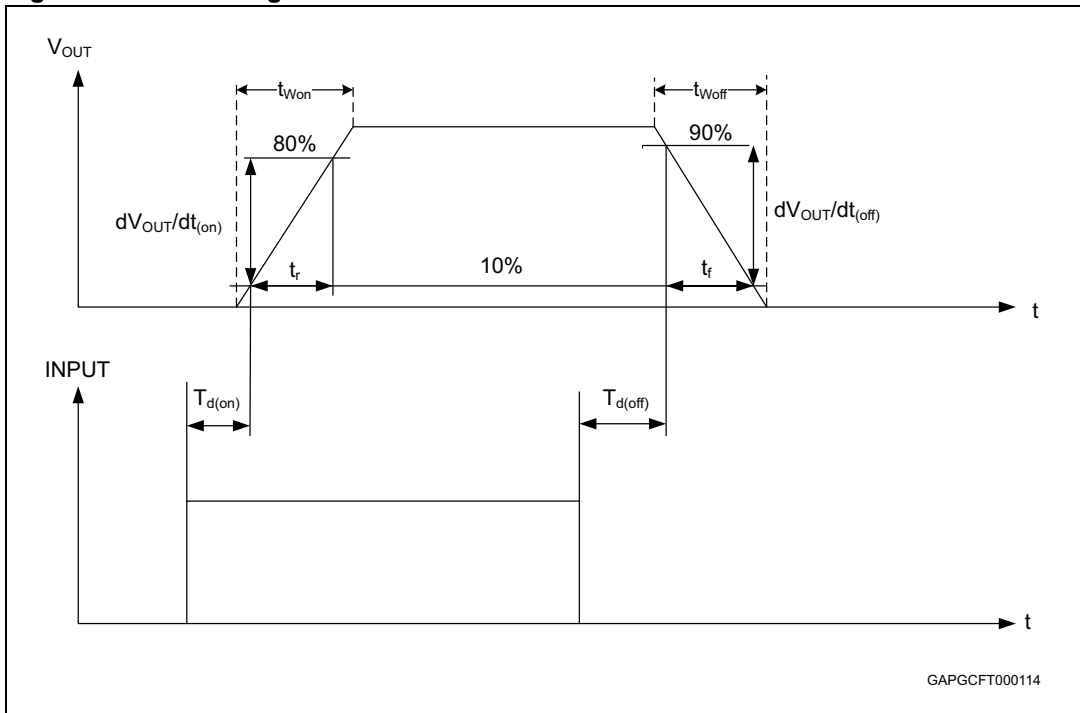

Figure 9. Output stuck to V_{CC} detection delay time at FRSTBY activation

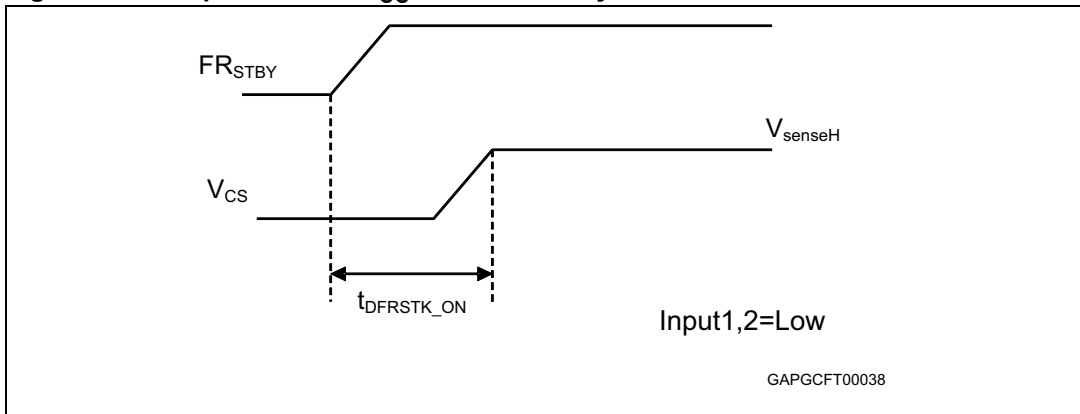

Figure 10. Delay response time between rising edge of output current and rising edge of current sense

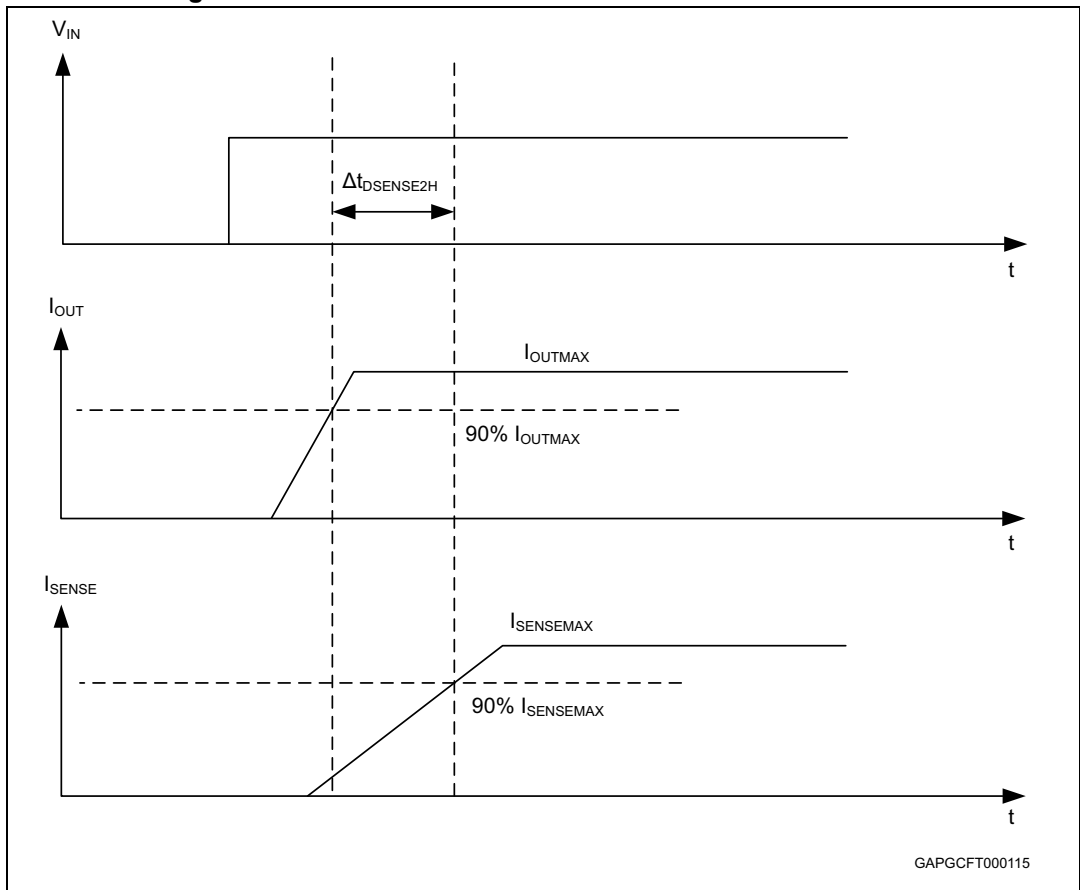

Figure 11. Output voltage drop limitation

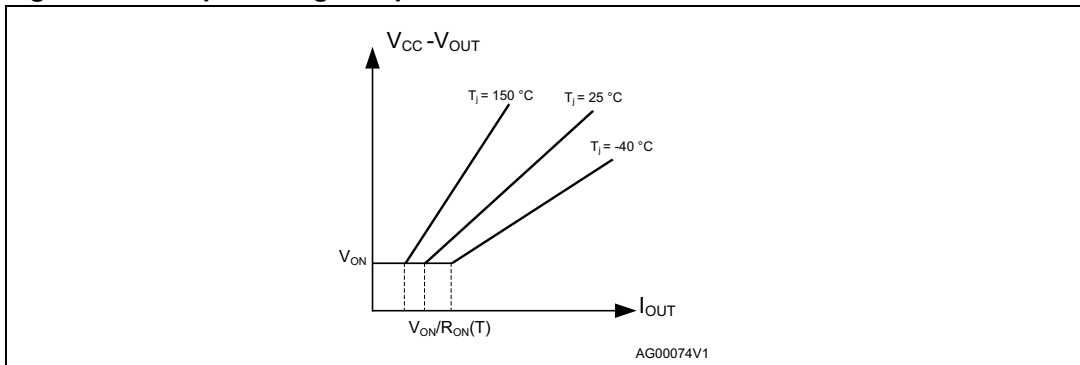

Figure 12. Device behavior in overload condition

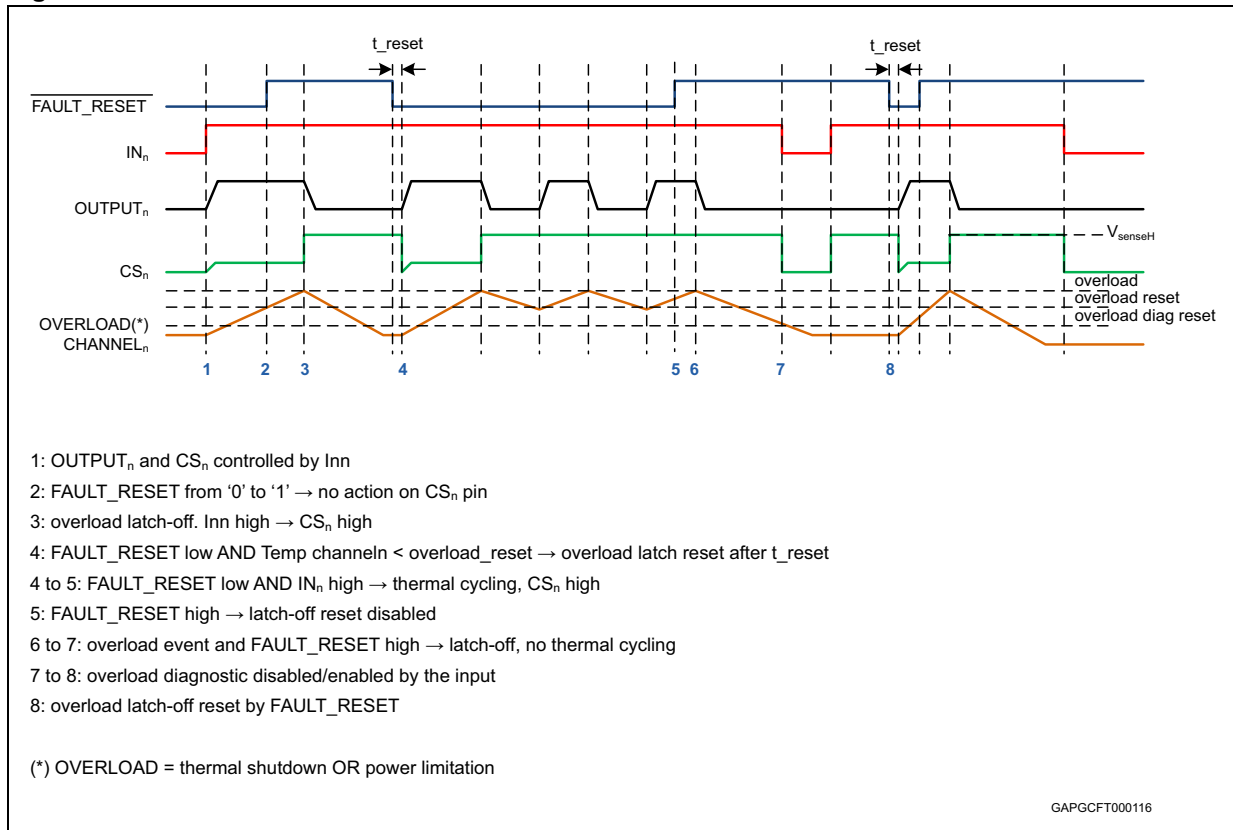

Table 11. Truth table

Conditions	Fault reset standby	Input	Output	Sense
Standby	L	L	L	0
Normal operation	X	L	L	0
	X	H	H	Nominal
Overload	X	L	L	0
	X	H	H	> Nominal
Overtemperature / short to ground	X	L	L	0
	L	H	Cycling	V_{SENSEH}
	H	H	Latched	V_{SENSEH}
Undervoltage	X	X	L	0
Short to V_{BAT}	L	L	H	0
	H	L	H	V_{SENSEH}
	X	H	H	< Nominal
Open-load off-state (with pull-up)	L	L	H	0
	H	L	H	V_{SENSEH}
	X	H	H	0
Negative output voltage clamp	X	L	Negative	0

Table 12. Electrical transient requirements (part 1)

ISO 7637-2: 2004(E) Test pulse	Test levels ⁽¹⁾		Number of pulses or test times	Burst cycle/pulse repetition time		Delays and impedance
	III	IV				
1	- 450 V	- 600 V	5000 pulses	0.5 s	5 s	1 ms, 50 Ω
2a	+ 37 V	+ 50 V	5000 pulses	0.2 s	5 s	50 μs, 2 Ω
3a	- 150 V	- 200 V	1h	90 ms	100 ms	0.1 μs, 50 Ω
3b	+ 150 V	+ 200 V	1h	90 ms	100 ms	0.1 μs, 50 Ω
4	- 12 V	- 16 V	1 pulse			100 ms, 0.01 Ω
5b ⁽²⁾	+ 123 V	+ 174 V	1 pulse			350 ms, 1 Ω

Table 13. Electrical transient requirements (part 2)

ISO 7637-2: 2004(E) Test pulse	Test level results	
	III	IV
1	C	C
2a	C	C
3a	C	C
3b ⁽¹⁾	E	E
3b ⁽²⁾	C	C
4	C	C
5b ⁽³⁾	C	C

1. Without capacitor between V_{CC} and GND.
2. With 10 nF between V_{CC} and GND.
3. External load dump clamp, 58 V maximum, referred to ground.

Table 14. Electrical transient requirements (part 3)

Class	Contents
C	All functions of the device are performed as designed after exposure to disturbance.
E	One or more functions of the device are not performed as designed after exposure to disturbance and cannot be returned to proper operation without replacing the device.

2.4 Electrical characteristics curves

Figure 13. Off-state output current

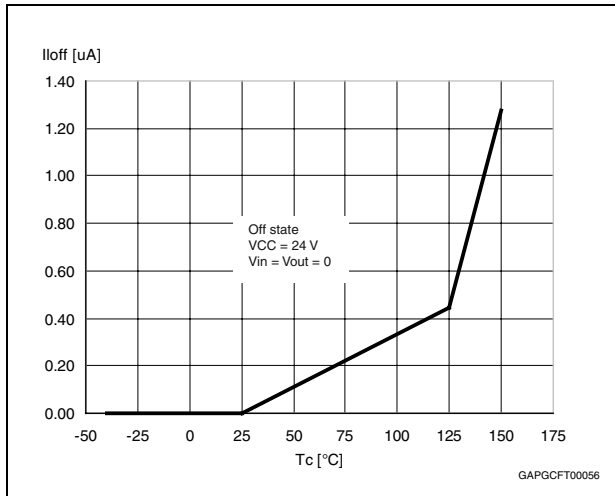

Figure 14. High level input current

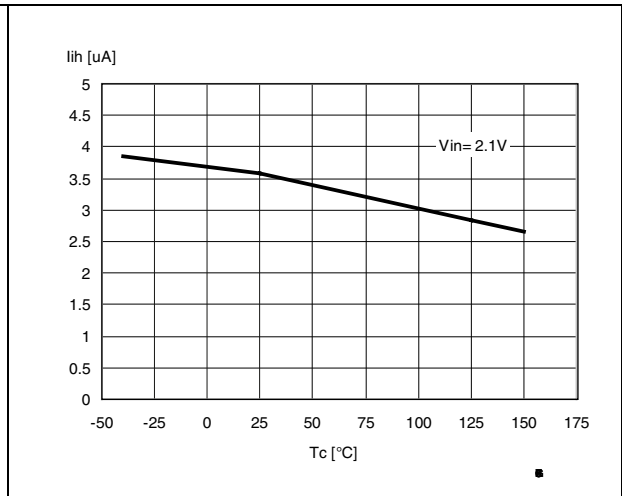

Figure 15. Input clamp voltage

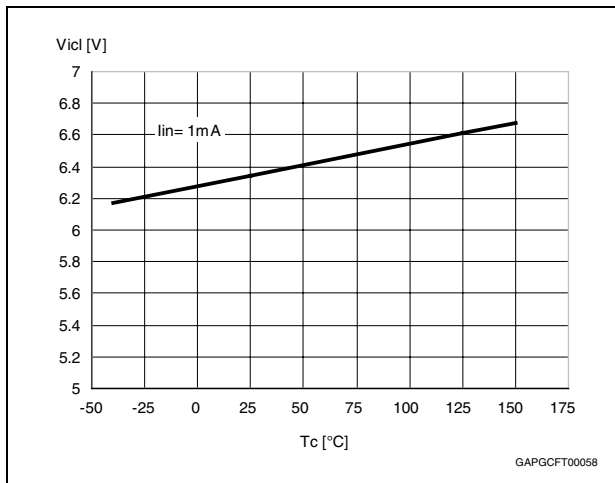

Figure 16. Input high level voltage

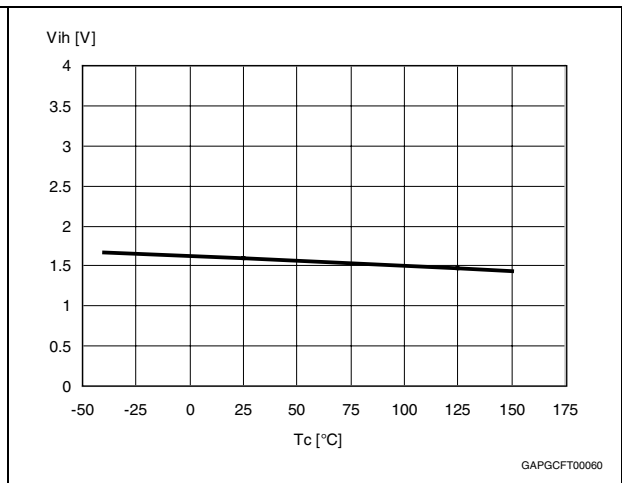

Figure 17. Input low level voltage

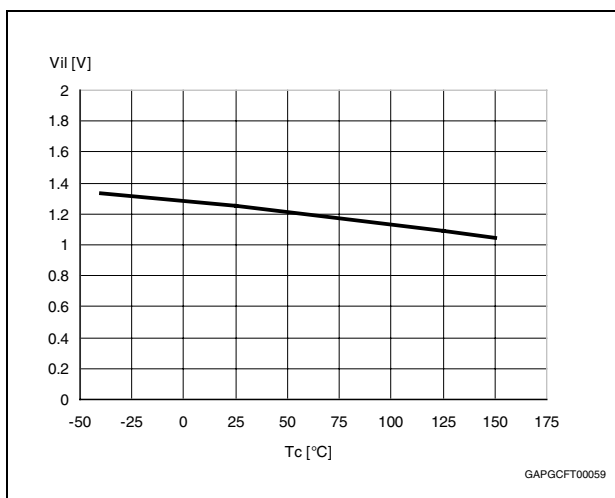

Figure 18. Input hysteresis voltage

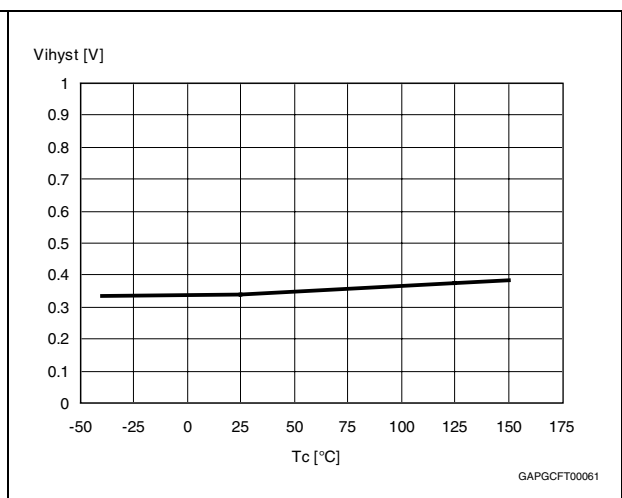

Figure 19. On-state resistance vs T_{case}

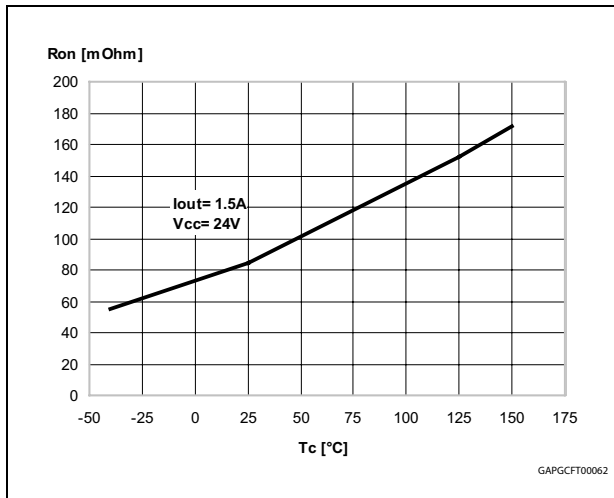

Figure 20. On-state resistance vs V_{CC}

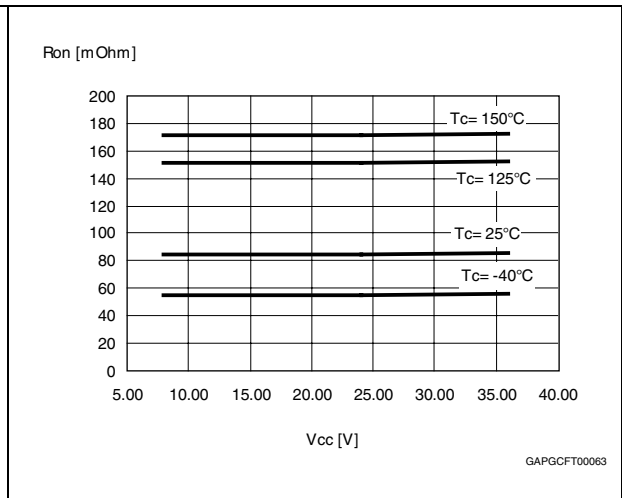

Figure 21. I_{LIMH} vs T_{case}

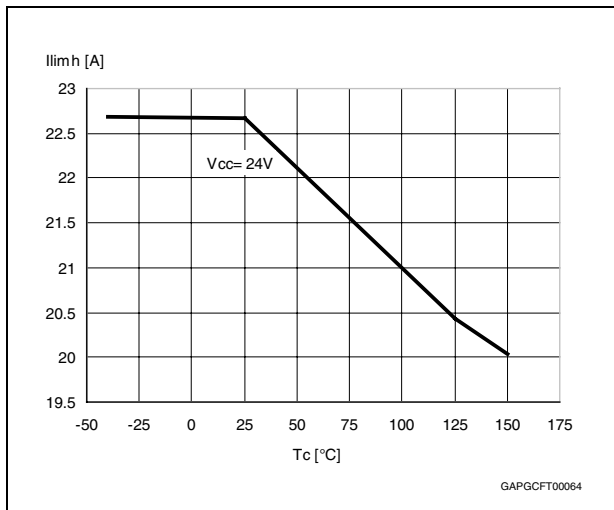

Figure 22. Turn-on voltage slope

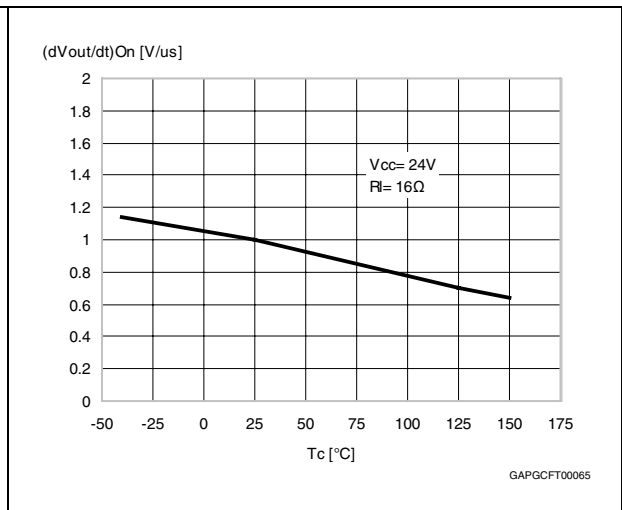
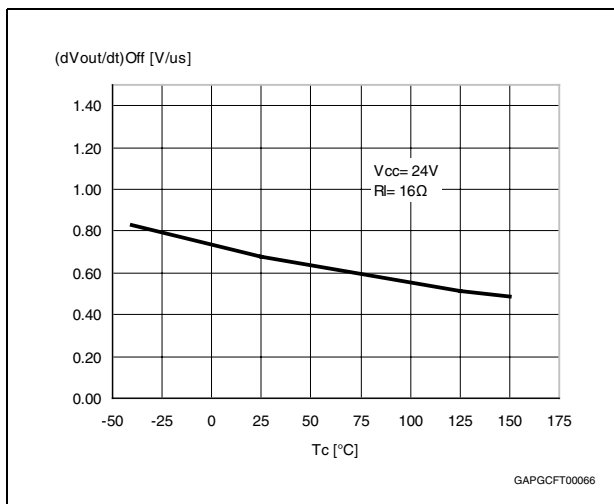
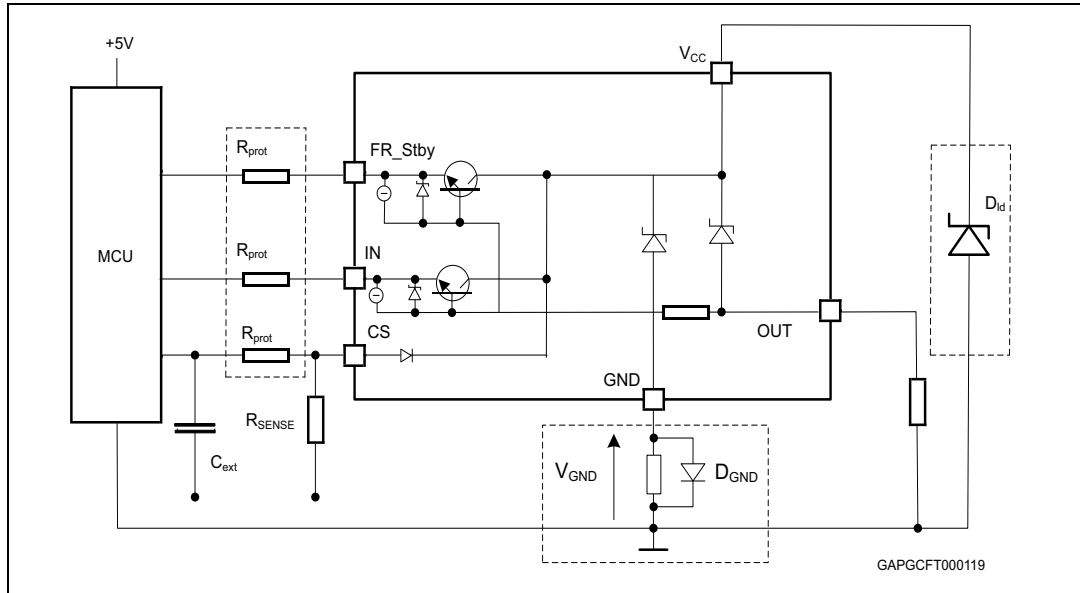

Figure 23. Turn-off voltage slope



3 Application information

Figure 24. Application schematic



3.1 GND protection network against reverse battery

3.1.1 Solution 1: resistor in the ground line (R_{GND} only)

This solution can be used with any type of load.

The following is an indication on how to dimension the R_{GND} resistor.

1. $R_{GND} \leq 600 \text{ mV} / (I_{S(on)max})$.
2. $R_{GND} \geq (-V_{CC}) / (-I_{GND})$

where $-I_{GND}$ is the DC reverse ground pin current and can be found in the absolute maximum rating section of the device datasheet.

Power dissipation in R_{GND} (when $V_{CC} < 0$: during reverse battery situations) is:

$$P_D = (-V_{CC})^2 / R_{GND}$$

This resistor can be shared amongst several different HSDs. Please note that the value of this resistor should be calculated with formula (1) where $I_{S(on)max}$ becomes the sum of the maximum on-state currents of the different devices.

Please note that if the microprocessor ground is not shared by the device ground then the R_{GND} produces a shift ($I_{S(on)max} * R_{GND}$) in the input thresholds and the status output values. This shift varies depending on how many devices are ON in the case of several high side drivers sharing the same R_{GND} .

If the calculated power dissipation leads to a large resistor or several devices have to share the same resistor then ST suggests Solution 2 is used (see below).

3.1.2 Solution 2: diode (D_{GND}) in the ground line

A resistor ($R_{GND} = 4.7 \text{ k}\Omega$) should be inserted in parallel to D_{GND} if the device drives an inductive load.

This small signal diode can be safely shared amongst several different HSDs. Also in this case, the presence of the ground network produces a shift ($\approx 600 \text{ mV}$) in the input threshold and in the status output values, if the microprocessor ground is not common to the device ground. This shift not varies if more than one HSD shares the same diode/resistor network.

3.2 Load dump protection

D_{ld} is necessary (Voltage Transient Suppressor) if the load dump peak voltage exceeds to V_{CC} max DC rating. The same applies if the device is subject to transients on the V_{CC} line that are greater than the ones shown in the ISO T/R 7637/2 table.

3.3 MCU I/Os protection

If a ground protection network is used and negative transient are present on the V_{CC} line, the control pins are pulled negative. ST suggests that a resistor (R_{prot}) be inserted in line to prevent the microcontroller I/O pins to latch-up.

The value of these resistors is a compromise between the leakage current of microcontroller and the current required by the HSD I/Os (Input levels compatibility) with the latch-up limit of microcontroller I/Os.

$$-V_{CCpeak}/I_{latchup} \leq R_{prot} \leq (V_{OH\mu C} - V_{IH} - V_{GND}) / I_{IHmax}$$

Calculation example:

For $V_{CCpeak} = -600 \text{ V}$ and $I_{latchup} \geq 20 \text{ mA}$; $V_{OH\mu C} \geq 4.5 \text{ V}$

$$30 \text{ k}\Omega \leq R_{prot} \leq 180 \text{ k}\Omega$$

Recommended R_{prot} value is $60 \text{ k}\Omega$.

3.4 Maximum demagnetization energy ($V_{CC} = 24\text{ V}$)

Figure 25. Maximum turn-off current versus inductance

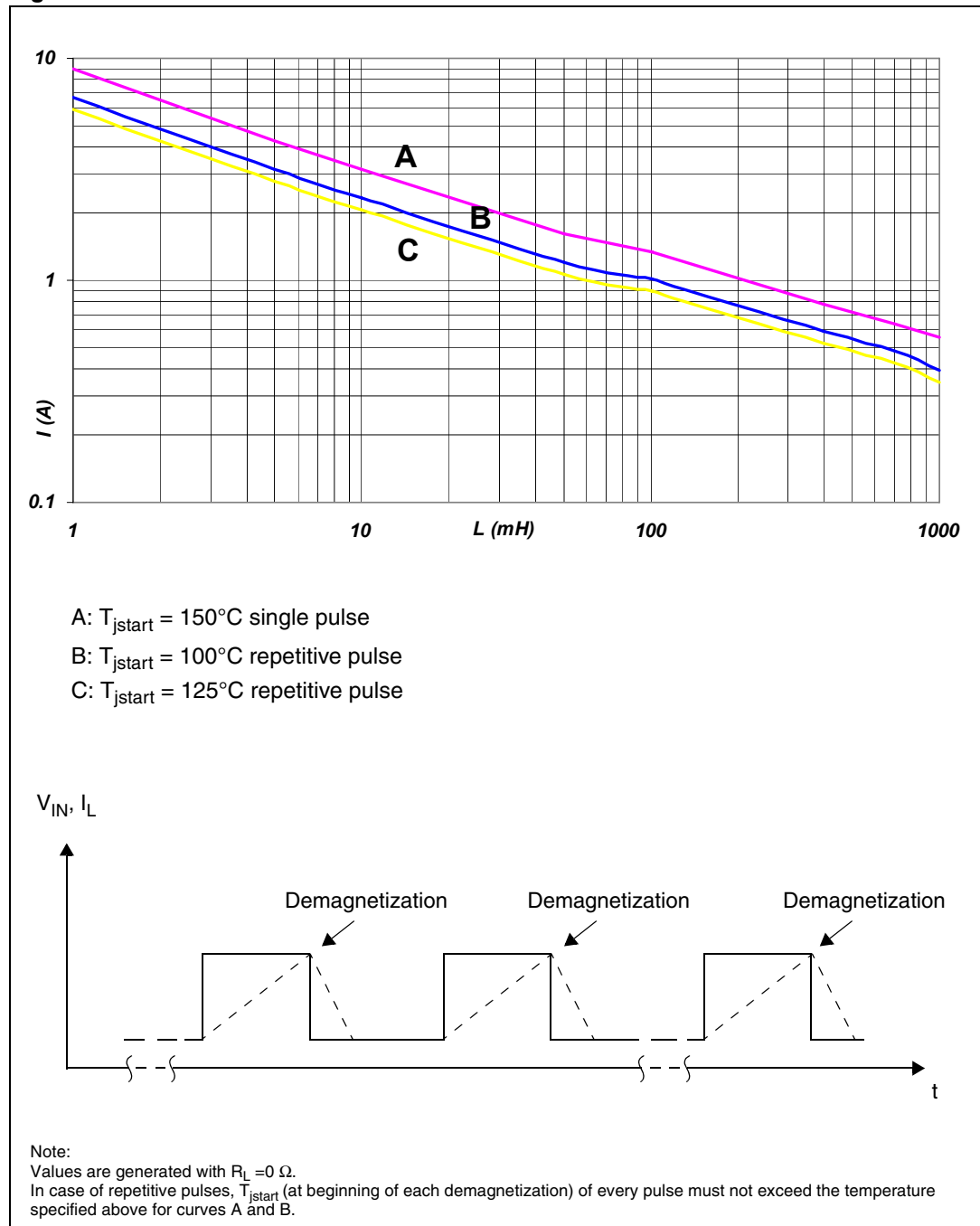

4 Package and PCB thermal data

4.1 PowerSSO-12 thermal data

Figure 26. PowerSSO-12 PC board

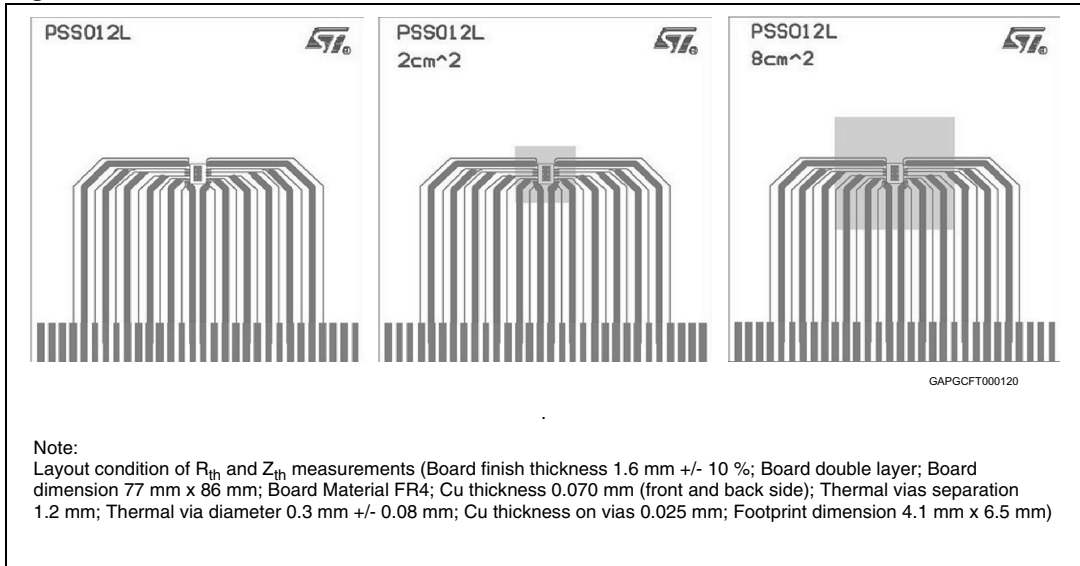

Figure 27. $R_{thj-amb}$ vs PCB copper area in open box free air condition (one channel ON)

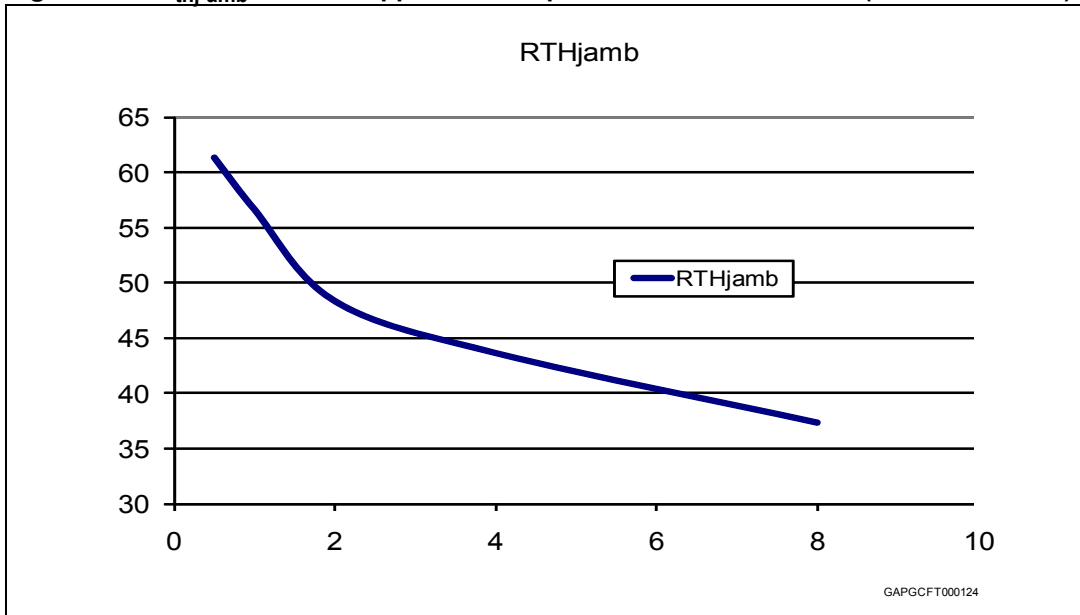

Figure 28. PowerSSO-12 thermal impedance junction ambient single pulse (one channel ON)

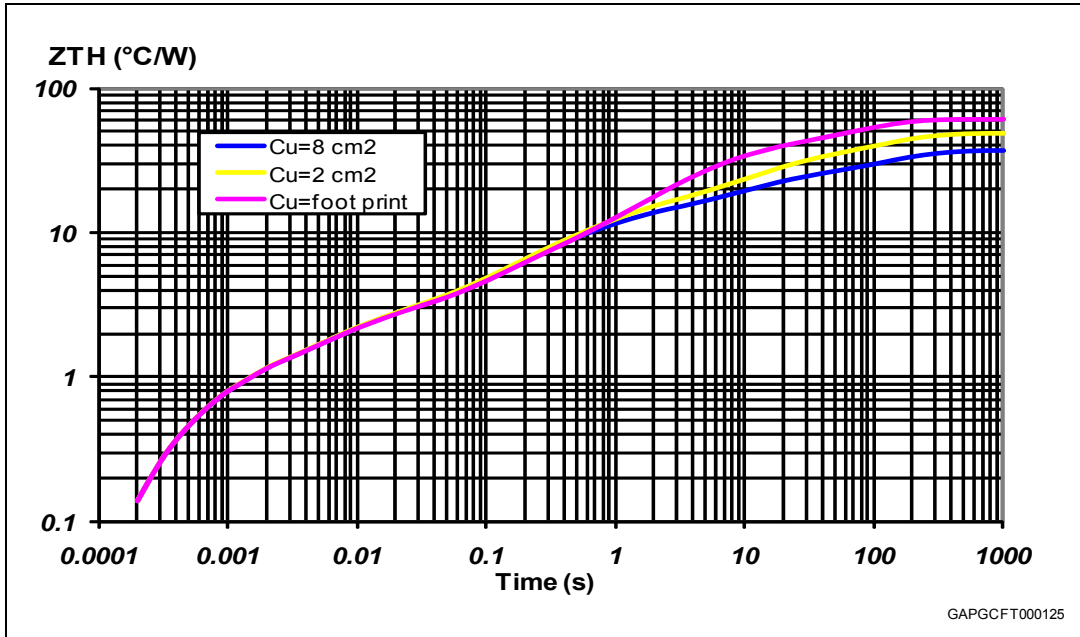
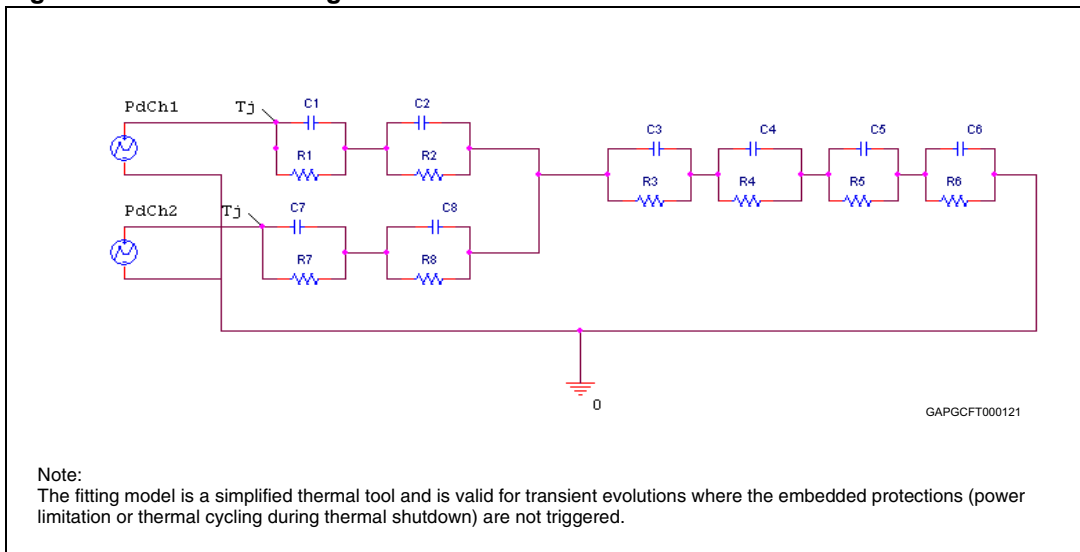

Figure 29. Thermal fitting model of a double channel HSD in PowerSSO-12



Note:
The fitting model is a simplified thermal tool and is valid for transient evolutions where the embedded protections (power limitation or thermal cycling during thermal shutdown) are not triggered.

Equation 1: pulse calculation formula

$$Z_{TH\delta} = R_{TH} \cdot \delta + Z_{THtp}(1 - \delta)$$

where $\delta = t_p/T$

Table 15. Thermal parameters

Area/island (cm ²)	Footprint	2	8
R1 = R7 (°C/W)	0.8		
R2 = R8 (°C/W)	1.5		
R3 (°C/W)	3		
R4 (°C/W)	8	8	7
R5 (°C/W)	22	15	10
R6 (°C/W)	26	20	15
C1 = C7 (W.s/°C)	0.0008		
C2 = C8 (W.s/°C)	0.005		
C3 (W.s/°C)	0.05		
C4 (W.s/°C)	0.2	0.1	0.1
C5 (W.s/°C)	0.27	0.8	1
C6 (W.s/°C)	3	6	9

5 Package and packing information

5.1 ECOPACK®

In order to meet environmental requirements, ST offers these devices in different grades of ECOPACK® packages, depending on their level of environmental compliance. ECOPACK® specifications, grade definitions and product status are available at: www.st.com.

ECOPACK® is an ST trademark.

5.2 PowerSSO-12 mechanical data

Figure 30. PowerSSO-12 package dimensions

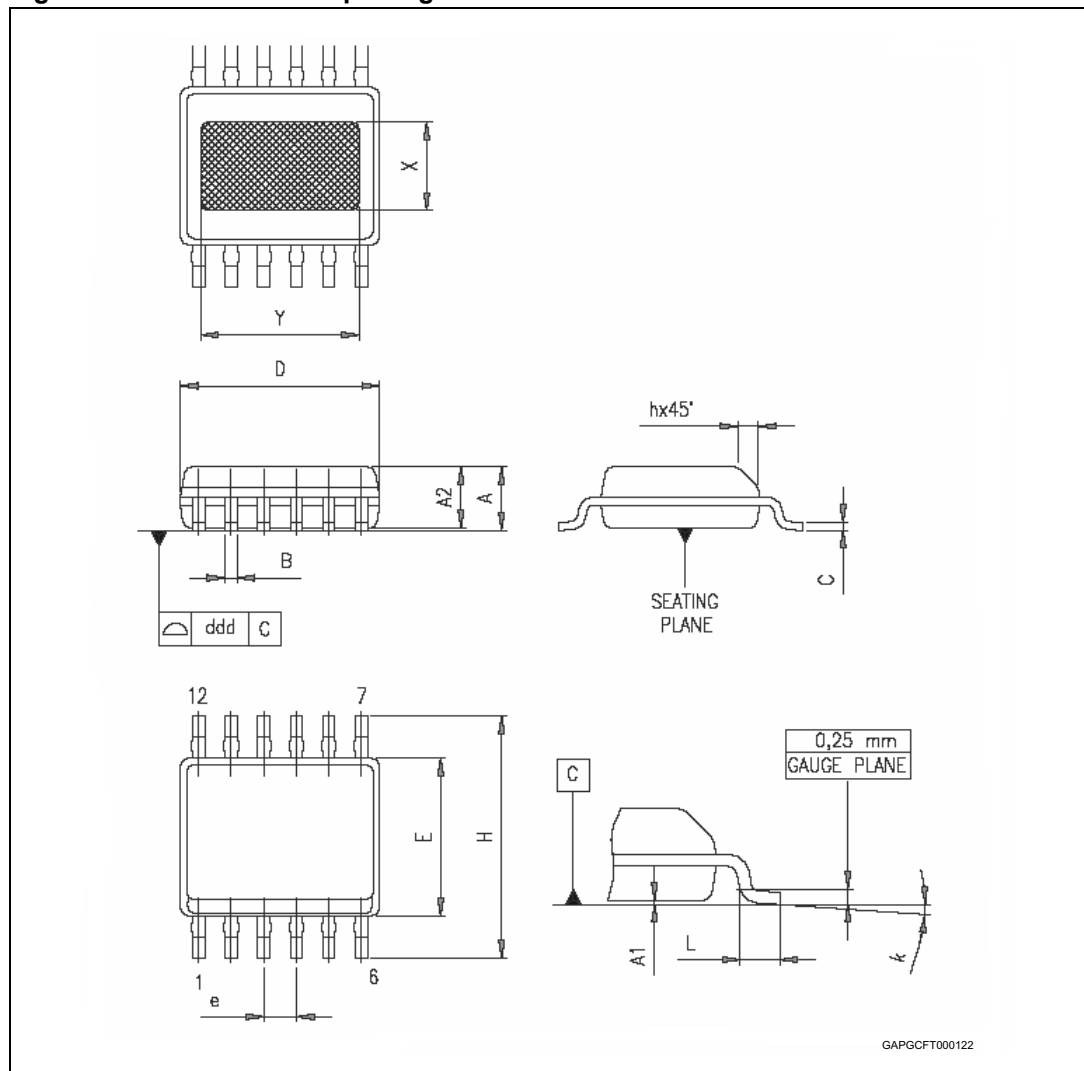

Table 16. PowerSSO-12 mechanical data

Symbol	Millimeters		
	Min.	Typ.	Max.
A	1.250	-	1.620
A1	0.000	-	0.100
A2	1.100	-	1.650
B	0.230	-	0.410
C	0.190	-	0.250
D	4.800	-	5.000
E	3.800	-	4.000
e	-	0.800	-
H	5.800	-	6.200
h	0.250	-	0.500
L	0.400	-	1.270
k	0°	-	8°
X	2.200	-	2.800
Y	2.900	-	3.500
ddd	-	-	0.100

5.3 Packing information

Figure 31. PowerSSO-12 tube shipment (no suffix)

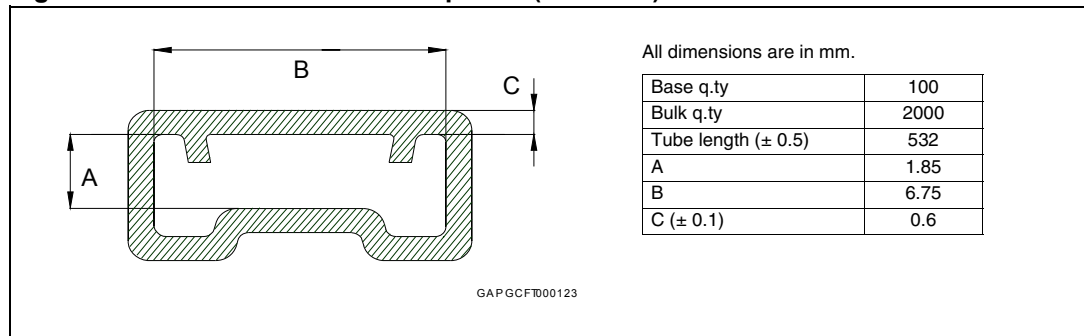
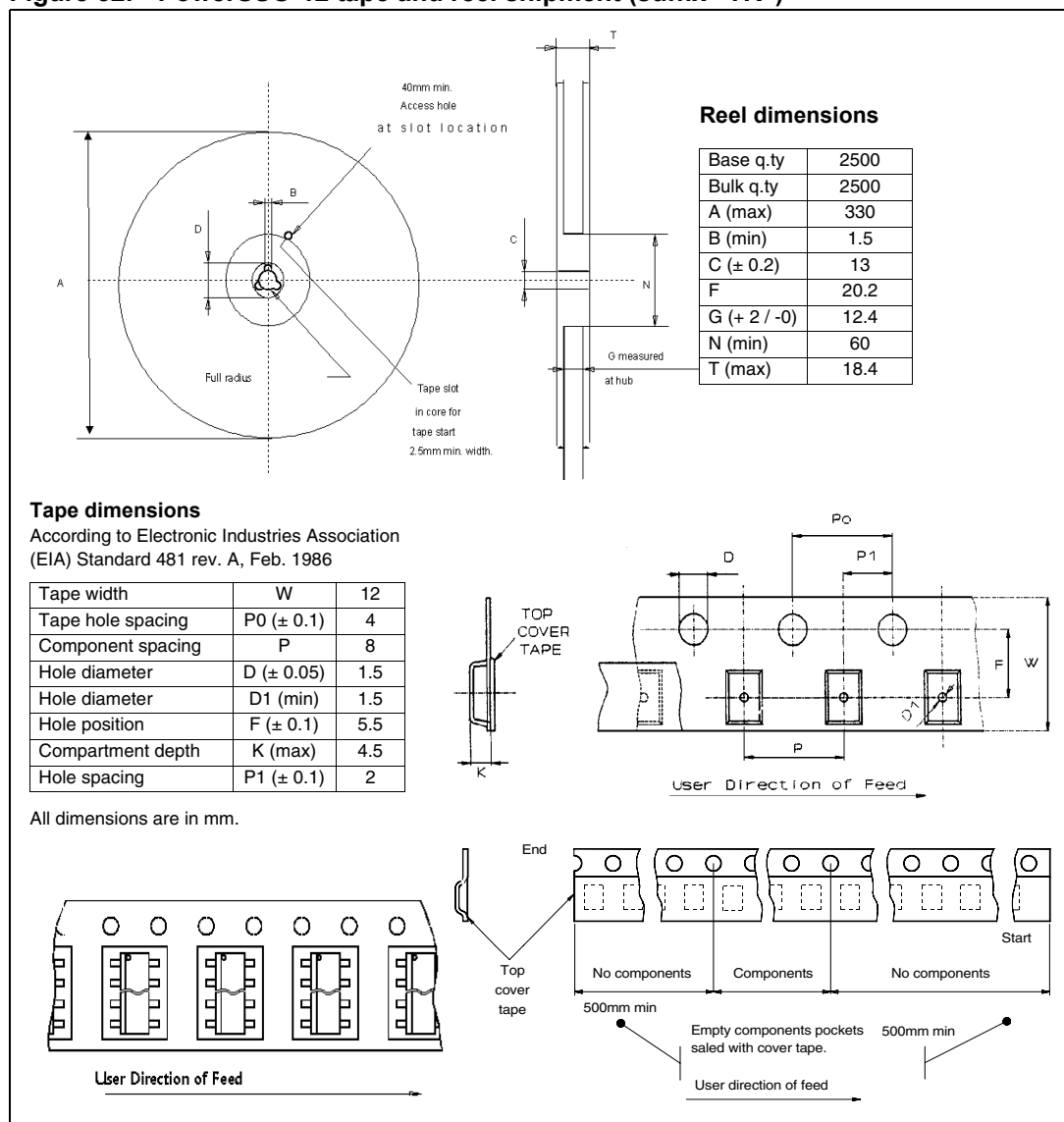

Figure 32. PowerSSO-12 tape and reel shipment (suffix "TR")



6 Order code

Table 17. Device summary

Package	Order codes	
	Tube	Tape and reel
PowerSSO-12	VND5T100AJ-E	VND5T100AJTR-E

7 Revision history

Table 18. Document revision history

Date	Revision	Changes
08-Mar-2011	1	Initial release.

Please Read Carefully:

Information in this document is provided solely in connection with ST products. STMicroelectronics NV and its subsidiaries ("ST") reserve the right to make changes, corrections, modifications or improvements, to this document, and the products and services described herein at any time, without notice.

All ST products are sold pursuant to ST's terms and conditions of sale.

Purchasers are solely responsible for the choice, selection and use of the ST products and services described herein, and ST assumes no liability whatsoever relating to the choice, selection or use of the ST products and services described herein.

No license, express or implied, by estoppel or otherwise, to any intellectual property rights is granted under this document. If any part of this document refers to any third party products or services it shall not be deemed a license grant by ST for the use of such third party products or services, or any intellectual property contained therein or considered as a warranty covering the use in any manner whatsoever of such third party products or services or any intellectual property contained therein.

UNLESS OTHERWISE SET FORTH IN ST'S TERMS AND CONDITIONS OF SALE ST DISCLAIMS ANY EXPRESS OR IMPLIED WARRANTY WITH RESPECT TO THE USE AND/OR SALE OF ST PRODUCTS INCLUDING WITHOUT LIMITATION IMPLIED WARRANTIES OF MERCHANTABILITY, FITNESS FOR A PARTICULAR PURPOSE (AND THEIR EQUIVALENTS UNDER THE LAWS OF ANY JURISDICTION), OR INFRINGEMENT OF ANY PATENT, COPYRIGHT OR OTHER INTELLECTUAL PROPERTY RIGHT.

UNLESS EXPRESSLY APPROVED IN WRITING BY AN AUTHORIZED ST REPRESENTATIVE, ST PRODUCTS ARE NOT RECOMMENDED, AUTHORIZED OR WARRANTED FOR USE IN MILITARY, AIR CRAFT, SPACE, LIFE SAVING, OR LIFE SUSTAINING APPLICATIONS, NOR IN PRODUCTS OR SYSTEMS WHERE FAILURE OR MALFUNCTION MAY RESULT IN PERSONAL INJURY, DEATH, OR SEVERE PROPERTY OR ENVIRONMENTAL DAMAGE. ST PRODUCTS WHICH ARE NOT SPECIFIED AS "AUTOMOTIVE GRADE" MAY ONLY BE USED IN AUTOMOTIVE APPLICATIONS AT USER'S OWN RISK.

Resale of ST products with provisions different from the statements and/or technical features set forth in this document shall immediately void any warranty granted by ST for the ST product or service described herein and shall not create or extend in any manner whatsoever, any liability of ST.

ST and the ST logo are trademarks or registered trademarks of ST in various countries.

Information in this document supersedes and replaces all information previously supplied.

The ST logo is a registered trademark of STMicroelectronics. All other names are the property of their respective owners.

© 2011 STMicroelectronics - All rights reserved

STMicroelectronics group of companies

Australia - Belgium - Brazil - Canada - China - Czech Republic - Finland - France - Germany - Hong Kong - India - Israel - Italy - Japan - Malaysia - Malta - Morocco - Philippines - Singapore - Spain - Sweden - Switzerland - United Kingdom - United States of America

www.st.com