



VND5025LAK-E

Double channel high side driver with analog current sense for automotive applications

Features

Max supply voltage	V_{CC}	41V
Operating voltage range	V_{CC}	4.5 to 36V
Max on-state resistance (per ch.)	R_{ON}	25m Ω
Current limitation (typ)	I_{LIMH}	60A
Off state supply current	I_S	2 μ A ⁽¹⁾

1. Typical value with all loads connected

■ Features

- In-rush current active management by power limitation
- Very low stand-by current
- 3.0V CMOS compatible input
- Optimized electromagnetic emission
- Very low electromagnetic susceptibility
- In compliance with the 2002/95/EC European directive
- Package: ECOPACK®

■ Diagnostic functions

- Proportional load current sense
- High current sense precision for wide range currents
- Current sense disable
- Thermal shutdown indication
- Very low current sense leakage

■ Protection

- Undervoltage shut-down
- Overvoltage clamp
- Load current limitation
- Self-limiting of fast thermal transients
- Protection against loss of ground and loss of V_{CC}



- Thermal shut down
- Reverse battery protection^(a)
- Electrostatic discharge protection

Description

The VND5025LAK-E is a monolithic device made using STMicroelectronics VIPower M0-5 technology, intended for driving resistive or inductive loads with one side connected to ground, and suitable for driving LEDs.

Active V_{CC} pin voltage clamp protects the device against low energy spikes (see ISO7637 transient compatibility table).

This device integrates an analog current sense which delivers a current proportional to the load current (according to a known ratio) when CS_DIS is driven low or left open.

When CS_DIS is driven high, the CURRENT SENSE pin is in a high impedance condition.

Output current limitation protects the device in overload condition. In case of long overload duration, the device limits the dissipated power to safe level up to thermal shut-down intervention. Thermal shut-down with automatic restart allows the device to recover normal operation as soon as fault condition disappears.

Table 1. Order codes

Package	Tube	Tape and Reel
PowerSSO-24™	VND5025LAK-E	VND5025LAKTR-E

a. See [Figure 26: Application schematic](#)

Contents

1	Block diagram and pin description	5
2	Electrical characteristics	6
2.1	Absolute maximum ratings	7
2.2	Thermal data	7
3	Application information	21
3.1	GND protection network against reverse battery	21
3.1.1	Solution 1: Resistor in the ground line (R_{GND} only)	21
3.1.2	Solution 2: Diode (D_{GND}) in the ground line	22
3.2	Load dump protection	22
3.3	μ C I/Os protection	22
3.4	Maximum demagnetization energy ($V_{CC} = 13.5V$)	23
4	Package and thermal data	24
4.1	PowerSSO-24™ thermal data	24
5	Package and packing information	27
5.1	ECOPACK® packages	27
5.2	Package mechanical	27
5.3	Packing information	29
6	Revision history	30

List of tables

Table 1.	Order codes	1
Table 2.	Pin functions	5
Table 3.	Absolute maximum ratings	7
Table 4.	Thermal data	7
Table 5.	Power section ($8V < V_{CC} < 36V$; $-40^{\circ}C < T_j < 150^{\circ}C$, unless otherwise specified)	8
Table 6.	Switching ($V_{CC} = 13V$; $T_j = 25^{\circ}C$)	8
Table 7.	Logic input	9
Table 8.	Protection and diagnostics	9
Table 9.	Current sense ($8V < V_{CC} < 16V$)	10
Table 10.	Truth table	14
Table 11.	Electrical transient requirements	16
Table 12.	Thermal parameters	26
Table 13.	PowerSSO-24™ mechanical data	27
Table 14.	Document revision history	30

List of figures

Figure 1.	Block diagram	5
Figure 2.	Configuration diagram (top view) and suggested connections for unused and N.C. pins	5
Figure 3.	Current and voltage conventions	6
Figure 4.	Current sense delay characteristics	11
Figure 5.	Delay response time between rising edge of output current and rising edge of current sense (CS enabled)	12
Figure 6.	I_{OUT}/I_{SENSE} vs I_{OUT} (see Table 9 for details)	13
Figure 7.	Maximum current sense ratio drift vs load current	14
Figure 8.	Switching characteristics	15
Figure 9.	Output voltage drop limitation	15
Figure 10.	Waveforms	17
Figure 11.	Off state output current	18
Figure 12.	High level input current	18
Figure 13.	Input clamp voltage	18
Figure 14.	Input high level	18
Figure 15.	Input low level	18
Figure 16.	Input hysteresis voltage	18
Figure 17.	On state resistance vs T_{case}	19
Figure 18.	On state resistance vs V_{CC}	19
Figure 19.	Undervoltage shutdown	19
Figure 20.	I_{LIMH} vs T_{case}	19
Figure 21.	Turn-on voltage slope	19
Figure 22.	Turn-off voltage slope	19
Figure 23.	CS_DIS high level voltage	20
Figure 24.	CS_DIS low level voltage	20
Figure 25.	CS_DIS clamp voltage	20
Figure 26.	Application schematic	21
Figure 27.	Maximum turn off current versus inductance (for each channel)	23
Figure 28.	PowerSSO-24™ PC board	24
Figure 29.	$R_{thj-amb}$ vs PCB copper area in open box free air condition (with one channel ON)	24
Figure 30.	PowerSSO-24™ thermal impedance junction to ambient single pulse (with one channel ON)	25
Figure 31.	Thermal fitting model of a double channel HSD in PowerSSO-24™(1)	26
Figure 32.	PowerSSO-24™ package dimensions	28
Figure 33.	PowerSSO-24™ tube shipment (no suffix)	29
Figure 34.	PowerSSO-24™ tape and reel shipment (suffix "TR")	29

1 Block diagram and pin description

Figure 1. Block diagram

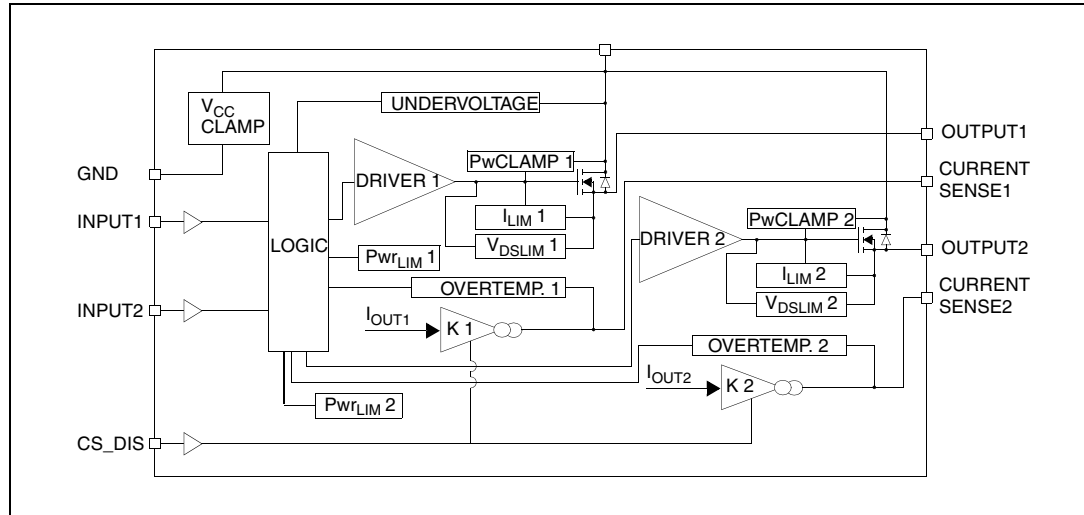
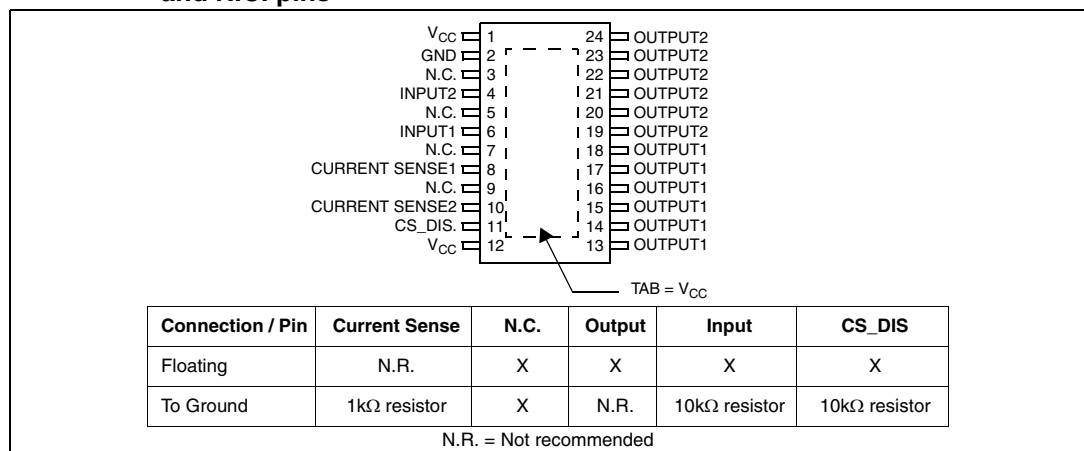

Table 2. Pin functions

Name	Function
V _{CC}	Battery connection
OUTPUT _{1,2}	Power output
GND	Ground connection; must be reverse battery protected by an external diode/resistor network
INPUT _{1,2}	Voltage controlled input pin with hysteresis, CMOS compatible; controls output switch state
CURRENT SENSE _{1,2}	Analog current sense pin; delivers a current proportional to the load current
CS_DIS	Active high CMOS compatible pin to disable the current sense pin

Figure 2. Configuration diagram (top view) and suggested connections for unused and N.C. pins



2 Electrical characteristics

Figure 3. Current and voltage conventions

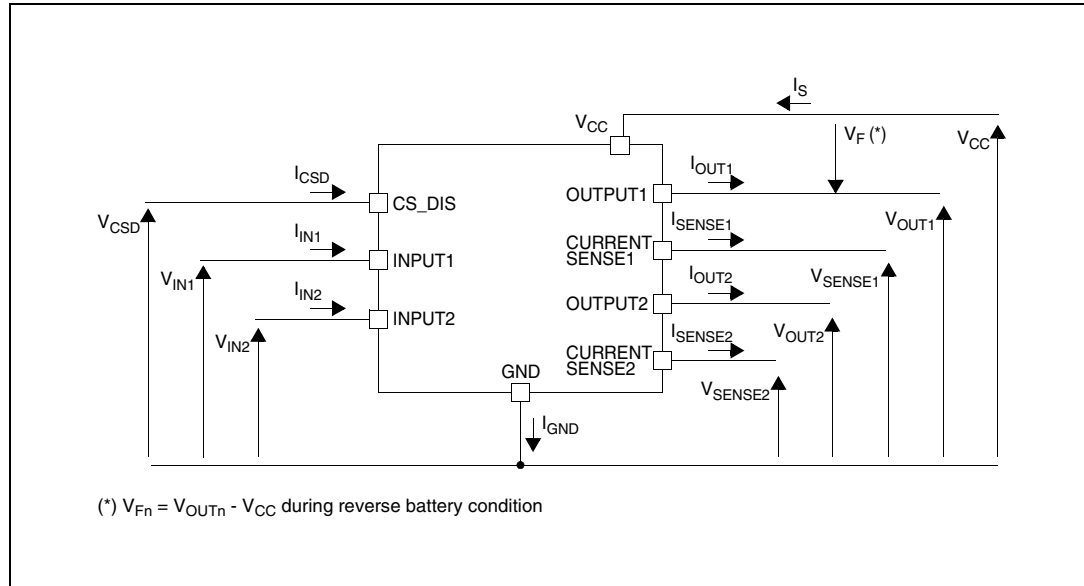

2.1 Absolute maximum ratings

Table 3. Absolute maximum ratings

Symbol	Parameter	Value	Unit
V_{CC}	DC supply voltage	41	V
$-V_{CC}$	Reverse DC supply voltage	0.3	
$-I_{GND}$	DC reverse ground pin current	200	mA
I_{OUT}	DC output current	Internally limited	A
$-I_{OUT}$	Reverse DC output current	24	
I_{IN}	DC input current	-1 to 10	mA
I_{CSD}	DC current sense disable input current		
$-I_{CSENSE}$	DC reverse CS pin current		
V_{CSENSE}	Current sense maximum voltage	$V_{CC} - 41$ to $+V_{CC}$	V
$E_{MAX}^{(1)}$	Maximum switching energy (single pulse) ($L = 0.3\text{mH}$; $R_L = 0\Omega$; $V_{bat} = 13.5\text{V}$; $T_{jstart} = 150^\circ\text{C}$; $I_{OUT} = I_{limL}(Typ.)$)	109	mJ
V_{ESD}	Electrostatic Discharge (Human Body Model: $R = 1.5\text{k}\Omega$; $C = 100\text{pF}$)		
	- Input	4000	V
	- Current sense	2000	V
	- CS_DIS	4000	V
	- Output	5000	V
	- V_{CC}	5000	V
V_{ESD}	Charge device model (CDM-AEC-Q100-011)	750	V
T_j	Junction operating temperature	-40 to 150	°C
T_{stg}	Storage temperature	-55 to 150	

1. See [Section 3.4](#) for details.

2.2 Thermal data

Table 4. Thermal data

Symbol	Parameter	Max Value	Unit
$R_{thj-case}$	Thermal resistance junction-case (MAX) (with one channel ON)	1.35	°C/W
$R_{thj-amb}$	Thermal resistance junction-ambient (MAX)	See Figure 29	

Table 5. Power section ($8V < V_{CC} < 36V$; $-40^{\circ}C < T_j < 150^{\circ}C$, unless otherwise specified)

Symbol	Parameter	Test conditions	Min	Typ	Max	Unit
V_{CC}	Operating supply voltage		4.5	13	36	V
V_{USD}	Undervoltage shutdown			3.5	4.5	
$V_{USDhyst}$	Undervoltage shut-down hysteresis			0.5		
R_{ON}	On state resistance ⁽¹⁾	$I_{OUT} = 3A$; $T_j = 25^{\circ}C$			25	mΩ
		$I_{OUT} = 3A$; $T_j = 150^{\circ}C$			50	
		$I_{OUT} = 3A$; $V_{CC} = 5V$; $T_j = 25^{\circ}C$			35	
V_{clamp}	Clamp voltage	$I_S = 20\text{ mA}$	41	46	52	V
I_S	Supply current	Off State; $V_{CC} = 13V$; $T_j = 25^{\circ}C$; $V_{IN} = V_{OUT} = V_{SENSE} = V_{CSD} = 0V$		2 ⁽²⁾	5 ⁽²⁾	μA
		On State; $V_{CC} = 13V$; $V_{IN} = 5V$; $I_{OUT} = 0A$		3	6	mA
$I_{L(off)}$	Off state output current ⁽¹⁾	$V_{IN} = V_{OUT} = 0V$; $V_{CC} = 13V$; $T_j = 25^{\circ}C$	0	0.01	3	μA
		$V_{IN} = V_{OUT} = 0V$; $V_{CC} = 13V$; $T_j = 125^{\circ}C$	0		5	
V_F	Output - V_{CC} diode voltage ⁽¹⁾	$-I_{OUT} = 4A$; $T_j = 150^{\circ}C$			0.7	V

1. For each channel
2. PowerMOS leakage included

Table 6. Switching ($V_{CC} = 13V$; $T_j = 25^{\circ}C$)

Symbol	Parameter	Test conditions	Min	Typ	Max	Unit
$t_{d(on)}$	Turn-on delay time	$R_L = 4.3\Omega$ (see Figure 8)		35		μs
$t_{d(off)}$	Turn-off delay time			50		
$(dV_{OUT}/dt)_{on}$	Turn-on voltage slope	$R_L = 4.3\Omega$		(see Figure 21)		V/μs
$(dV_{OUT}/dt)_{off}$	Turn-off voltage slope			(see Figure 22)		
W_{ON}	Switching energy losses during t_{WON}	$R_L = 4.3\Omega$ (see Figure 8)		0.45		mJ
W_{OFF}	Switching energy losses during t_{WOFF}			0.35		

Table 7. Logic input

Symbol	Parameter	Test conditions	Min	Typ	Max	Unit
V_{IL}	Input low level voltage				0.9	V
I_{IL}	Low level input current	$V_{IN} = 0.9V$	1			μA
V_{IH}	Input high level voltage		2.1			V
I_{IH}	High level input current	$V_{IN} = 2.1V$			10	μA
$V_{I(hyst)}$	Input hysteresis voltage		0.25			V
V_{ICL}	Input clamp voltage	$I_{IN} = 1mA$	5.5		7	
		$I_{IN} = -1mA$		-0.7		
V_{CSDL}	CS_DIS low level voltage				0.9	μA
I_{CSDL}	Low level CS_DIS current	$V_{CSD} = 0.9V$	1			
V_{CSDH}	CS_DIS high level voltage		2.1			V
I_{CSDH}	High level CS_DIS current	$V_{CSD} = 2.1V$			10	μA
$V_{CSD(hyst)}$	CS_DIS hysteresis voltage		0.25			V
V_{CSCL}	CS_DIS clamp voltage	$I_{CSD} = 1mA$	5.5		7	
		$I_{CSD} = -1mA$		-0.7		

Table 8. Protection and diagnostics⁽¹⁾

Symbol	Parameter	Test conditions	Min	Typ	Max	Unit
I_{LIMH}	DC short circuit current	$V_{CC} = 13V$	43	60	85	A
		$5V < V_{CC} < 36V$				
I_{LIML}	Short circuit current during thermal cycling	$V_{CC} = 13V$; $T_R < T_j < T_{TSD}$		24		
T_{TSD}	Shutdown temperature		150	175	200	°C
T_R	Reset temperature		$T_{RS} + 1$	$T_{RS} + 5$		
T_{RS}	Thermal reset of STATUS		135			
T_{HYST}	Thermal hysteresis ($T_{TSD} - T_R$)			7		
V_{DEMAG}	Turn-off output voltage clamp	$I_{OUT} = 2A$; $V_{IN} = 0$; $L = 6mH$	$V_{CC} - 41$	$V_{CC} - 46$	$V_{CC} - 52$	V
V_{ON}	Output voltage drop limitation	$I_{OUT} = 0.2A$; $T_j = -40^\circ C$ to $+150^\circ C$ (see Figure 9)		40		mV

1. To ensure long term reliability under heavy overload or short circuit conditions, protection and related diagnostic signals must be used together with a proper software strategy. If the device is subjected to abnormal conditions, this software must limit the duration and number of activation cycles.

Table 9. Current sense ($8V < V_{CC} < 16V$)

Symbol	Parameter	Test conditions	Min	Typ	Max	Unit
K_{LED}	I_{OUT}/I_{SENSE}	$I_{OUT} = 0.05A; V_{SENSE} = 0.5V; V_{CSD} = 0V;$ $T_j = -40^{\circ}C \text{ to } 150^{\circ}C$	1450	3300	5180	
K_0	I_{OUT}/I_{SENSE}	$I_{OUT} = 0.5A; V_{SENSE} = 0.5V; V_{CSD} = 0V;$ $T_j = -40^{\circ}C \text{ to } 150^{\circ}C$	1720	3020	4360	
K_1	I_{OUT}/I_{SENSE}	$I_{OUT} = 2A; V_{SENSE} = 4V;$ $V_{CSD} = 0V;$ $T_j = -40^{\circ}C$ $T_j = 25^{\circ}C \text{ to } 150^{\circ}C$	1940 2230	2810 2810	3740 3390	
$dK_1/K_1^{(1)}$	Current sense ratio drift	$I_{OUT} = 2A; V_{SENSE} = 4V;$ $V_{CSD} = 0V;$ $T_j = -40^{\circ}C \text{ to } 150^{\circ}C$	-10		+10	%
K_2	I_{OUT}/I_{SENSE}	$I_{OUT} = 3A; V_{SENSE} = 4V;$ $V_{CSD} = 0V;$ $T_j = -40^{\circ}C$ $T_j = 25^{\circ}C \text{ to } 150^{\circ}C$	2250 2400	2790 2790	3450 3180	
$dK_2/K_2^{(1)}$	Current sense ratio drift	$I_{OUT} = 3A; V_{SENSE} = 4V; V_{CSD} = 0V;$ $T_j = -40^{\circ}C \text{ to } 150^{\circ}C$	-7		+7	%
K_3	I_{OUT}/I_{SENSE}	$I_{OUT} = 10A; V_{SENSE} = 4V;$ $V_{CSD} = 0V;$ $T_j = -40^{\circ}C$ $T_j = 25^{\circ}C \text{ to } 150^{\circ}C$	2610 2650	2760 2760	2970 2870	
$dK_3/K_3^{(1)}$	Current sense ratio drift	$I_{OUT} = 10A; V_{SENSE} = 4V; V_{CSD} = 0V;$ $T_j = -40^{\circ}C \text{ to } 150^{\circ}C$	-3		+3	%
I_{SENSE0}	Analog sense leakage current	$I_{OUT} = 0A; V_{SENSE} = 0V;$ $V_{CSD} = 5V; V_{IN} = 0V; T_j = -40^{\circ}C \text{ to } 150^{\circ}C$	0		1	μA
		$V_{CSD} = 0V; V_{IN} = 5V; T_j = -40^{\circ}C \text{ to } 150^{\circ}C$	0		2	μA
		$I_{OUT} = 2A; V_{SENSE} = 0V;$ $V_{CSD} = 5V; V_{IN} = 5V; T_j = -40^{\circ}C \text{ to } 150^{\circ}C$	0		1	μA
V_{SENSE}	Max analog sense output voltage	$I_{OUT} = 3A; V_{CSD} = 0V$	5			V
V_{SENSEH}	Analog sense output voltage in overtemperature condition	$V_{CC} = 13V; R_{SENSE} = 3.9k\Omega$		9		
I_{SENSEH}	Analog sense output current in overtemperature condition	$V_{CC} = 13V; V_{SENSE} = 5V$		8		mA

Table 9. Current sense (8V < V_{CC} < 16V) (continued)

Symbol	Parameter	Test conditions	Min	Typ	Max	Unit
t _{DSENSE1H}	Delay response time from falling edge of CS_DIS pin	V _{SENSE} < 4V, 0.5 < I _{OUT} < 10A I _{SENSE} = 90% of I _{SENSEMAX} (see Figure 4)		50	100	μs
t _{DSENSE1L}	Delay response time from rising edge of CS_DIS pin	V _{SENSE} < 4V, 0.5 < I _{OUT} < 10A I _{SENSE} = 10% of I _{SENSEMAX} (see Figure 4)		5	20	
t _{DSENSE2H}	Delay response time from rising edge of INPUT pin	V _{SENSE} < 4V, 0.5 < I _{OUT} < 10A I _{SENSE} = 90% of I _{SENSEMAX} (see Figure 4)		70	300	
Δt _{DSENSE2H}	Delay response time between rising edge of output current and rising edge of current sense	V _{SENSE} < 4V, I _{SENSE} = 90% of I _{SENSEMAX} , I _{OUT} = 90% of I _{OUTMAX} , I _{OUTMAX} = 3A (see Figure 5)			110	
t _{DSENSE2L}	Delay response time from falling edge of INPUT pin	V _{SENSE} < 4V, 0.5 < I _{OUT} < 10A I _{SENSE} = 10% of I _{SENSEMAX} (see Figure 4)		100	250	

1. Parameter guaranteed by design; it is not tested.

Figure 4. Current sense delay characteristics

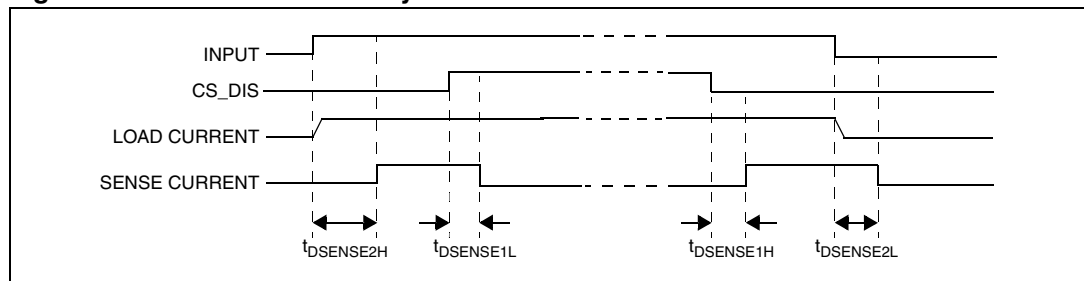

Figure 5. Delay response time between rising edge of output current and rising edge of current sense (CS enabled)

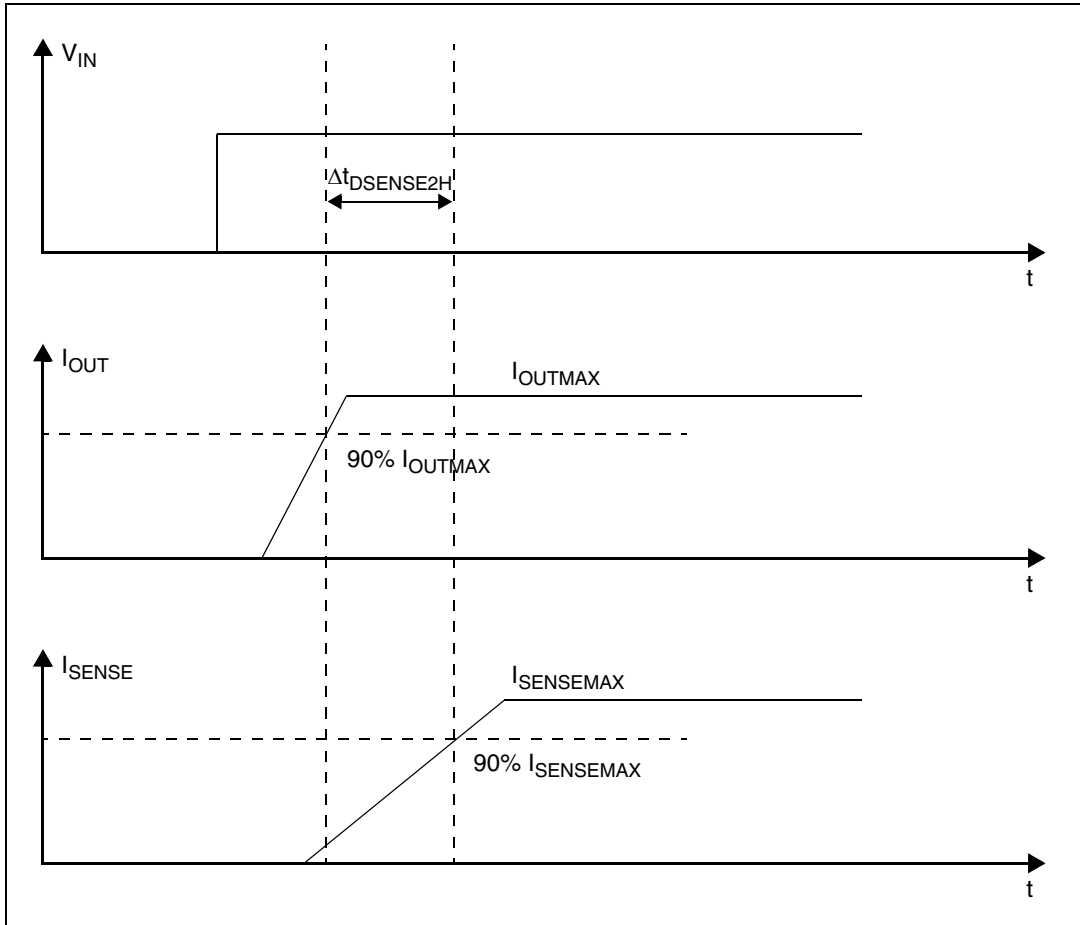

Figure 6. I_{OUT}/I_{SENSE} vs I_{OUT} (see Table 9 for details)

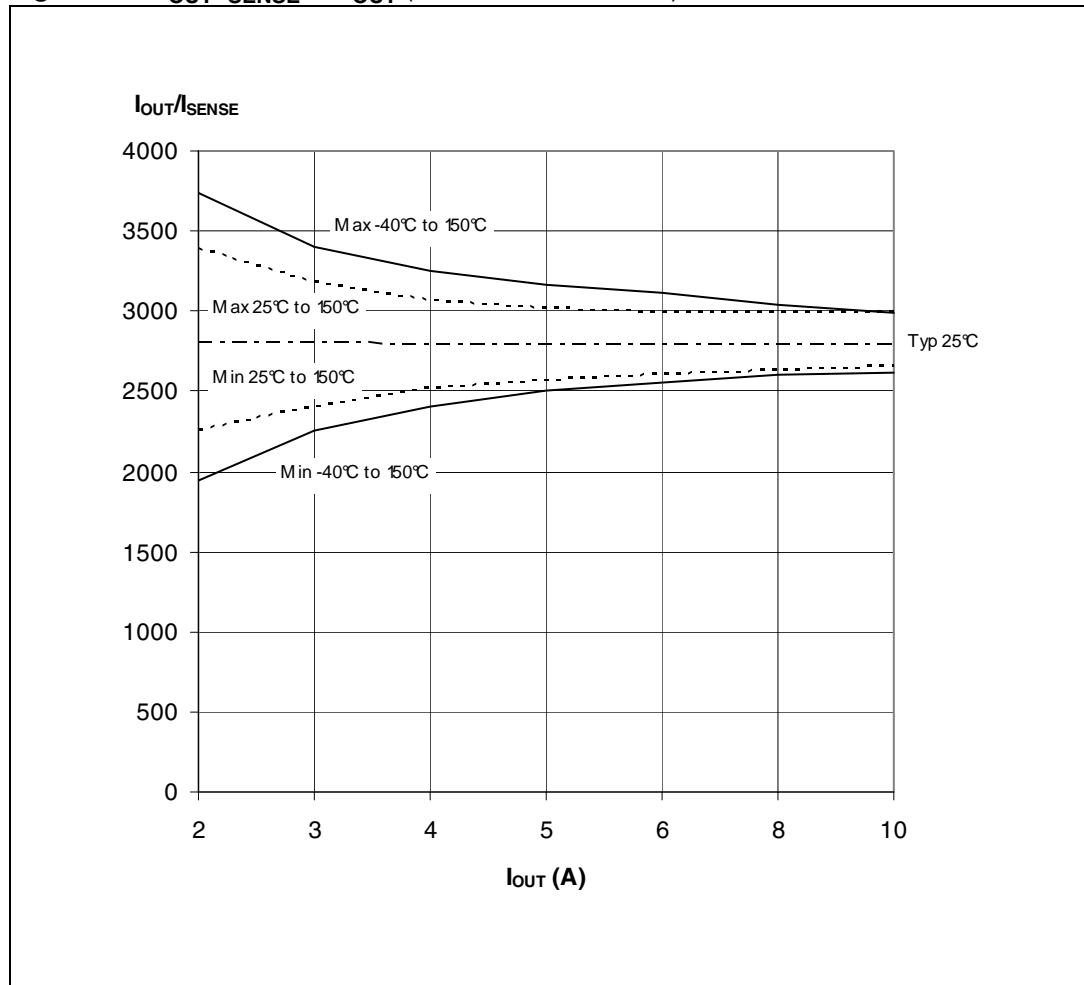

Figure 7. Maximum current sense ratio drift vs load current

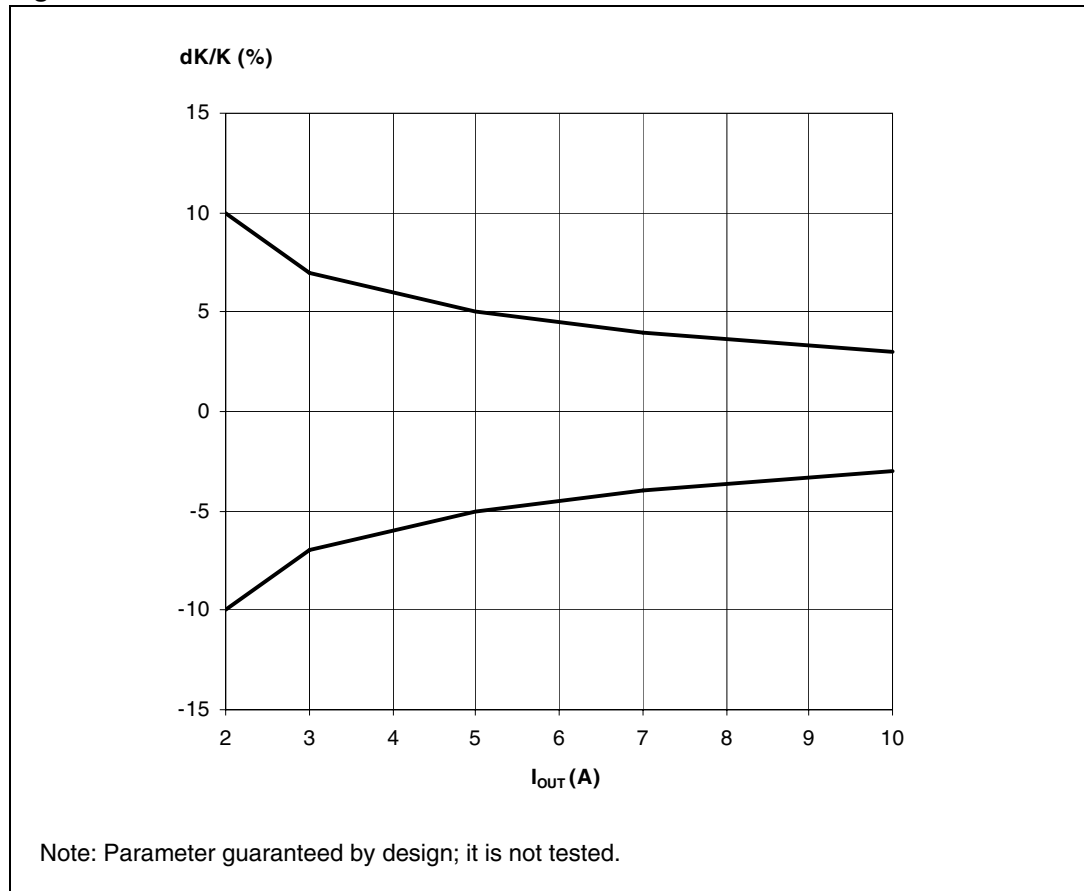

Table 10. Truth table

Conditions	Input	Output	Sense ($V_{CSD} = 0V$) ⁽¹⁾
Normal operation	L	L	0
	H	H	Nominal
Overtemperature	L	L	0
	H		V_{SENSEH}
Undervoltage	L	L	0
	H		0
Short circuit to GND ($R_{SC} \leq 10m\Omega$)	L	L	0
	H		0 if $T_j < T_{TSD}$ V_{SENSEH} if $T_j > T_{TSD}$
Short circuit to V_{CC}	L	H	0
	H		< Nominal
Negative output voltage clamp	L	L	0

1. If the V_{CSD} is high, the SENSE output is at a high impedance; its potential depends on leakage currents and external circuit.

Figure 8. Switching characteristics

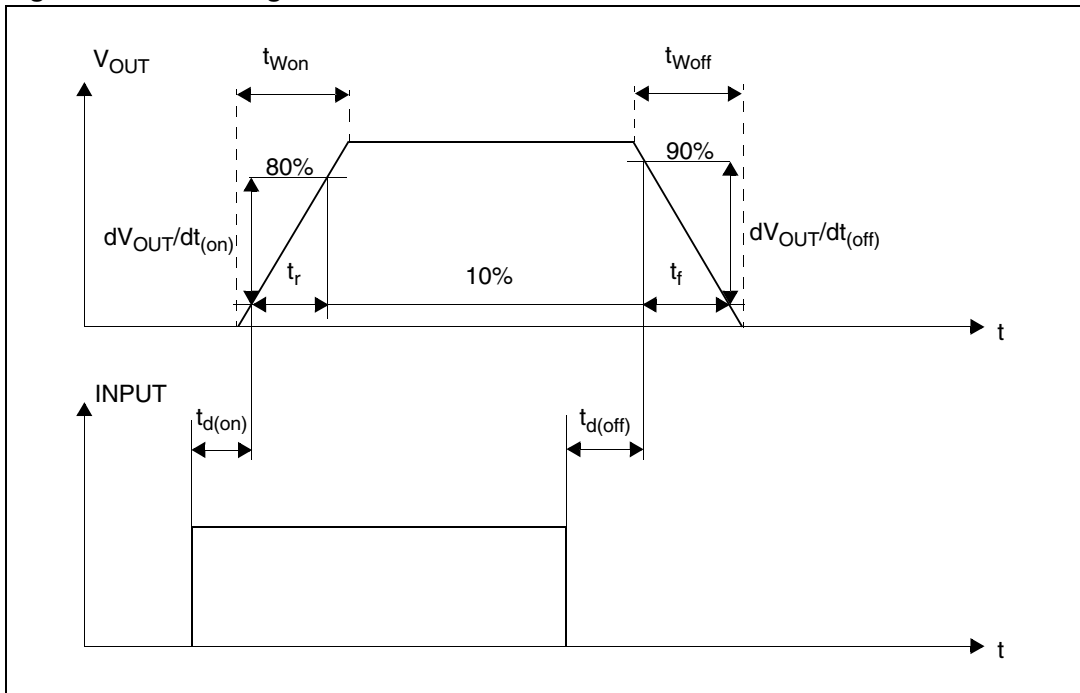

Figure 9. Output voltage drop limitation

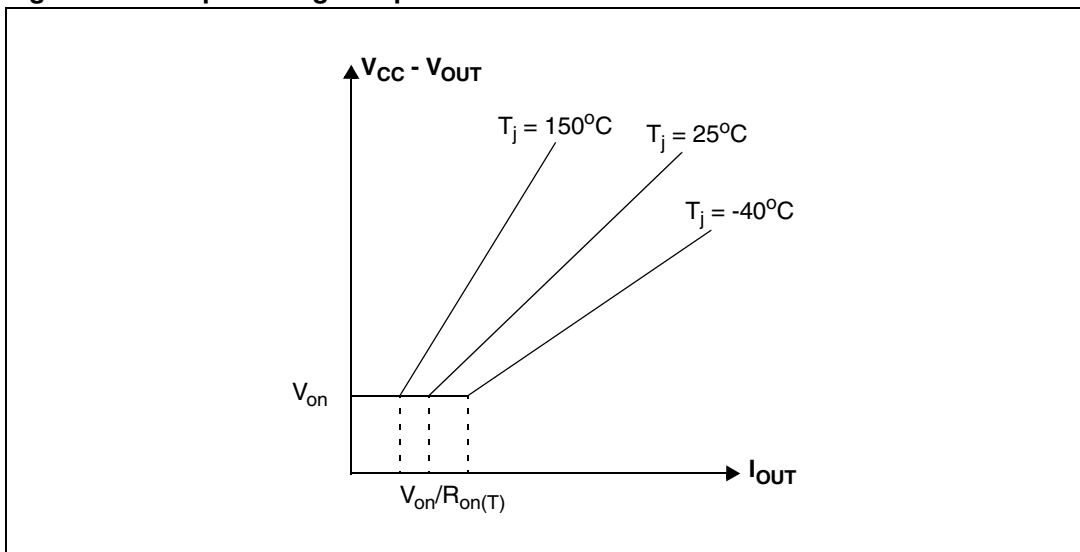

Table 11. Electrical transient requirements

ISO 7637-2: 2004(E) Test pulse	Test levels ⁽¹⁾		Number of pulses or test times	Burst cycle/pulse repetition time		Delays and Impedance
	III	IV		Min	Max	
1	-75V	-100V	5000 pulses	0.5s	5s	2 ms, 10Ω
2a	+37V	+50V	5000 pulses	0.2s	5s	50μs, 2Ω
3a	-100V	-150V	1h	90ms	100ms	0.1μs, 50Ω
3b	+75V	+100V	1h	90ms	100ms	0.1μs, 50Ω
4	-6V	-7V	1 pulse			100ms, 0.01Ω
5b ⁽²⁾	+65V	+87V	1 pulse			400ms, 2Ω

ISO 7637-2: 2004E Test pulse	Test level results	
	III	VI
1	C	C
2a	C	C
3a	C	C
3b	C	C
4	C	C
5b ⁽²⁾	C	C

Class	Contents
C	All functions of the device performed as designed after exposure to disturbance.
E	One or more functions of the device did not perform as designed after exposure to disturbance and cannot be returned to proper operation without replacing the device.

1. The above test levels must be considered referred to V_{CC} = 13.5V except for pulse 5b.
2. Valid in case of external load dump clamp: 40V maximum referred to ground.

Figure 10. Waveforms

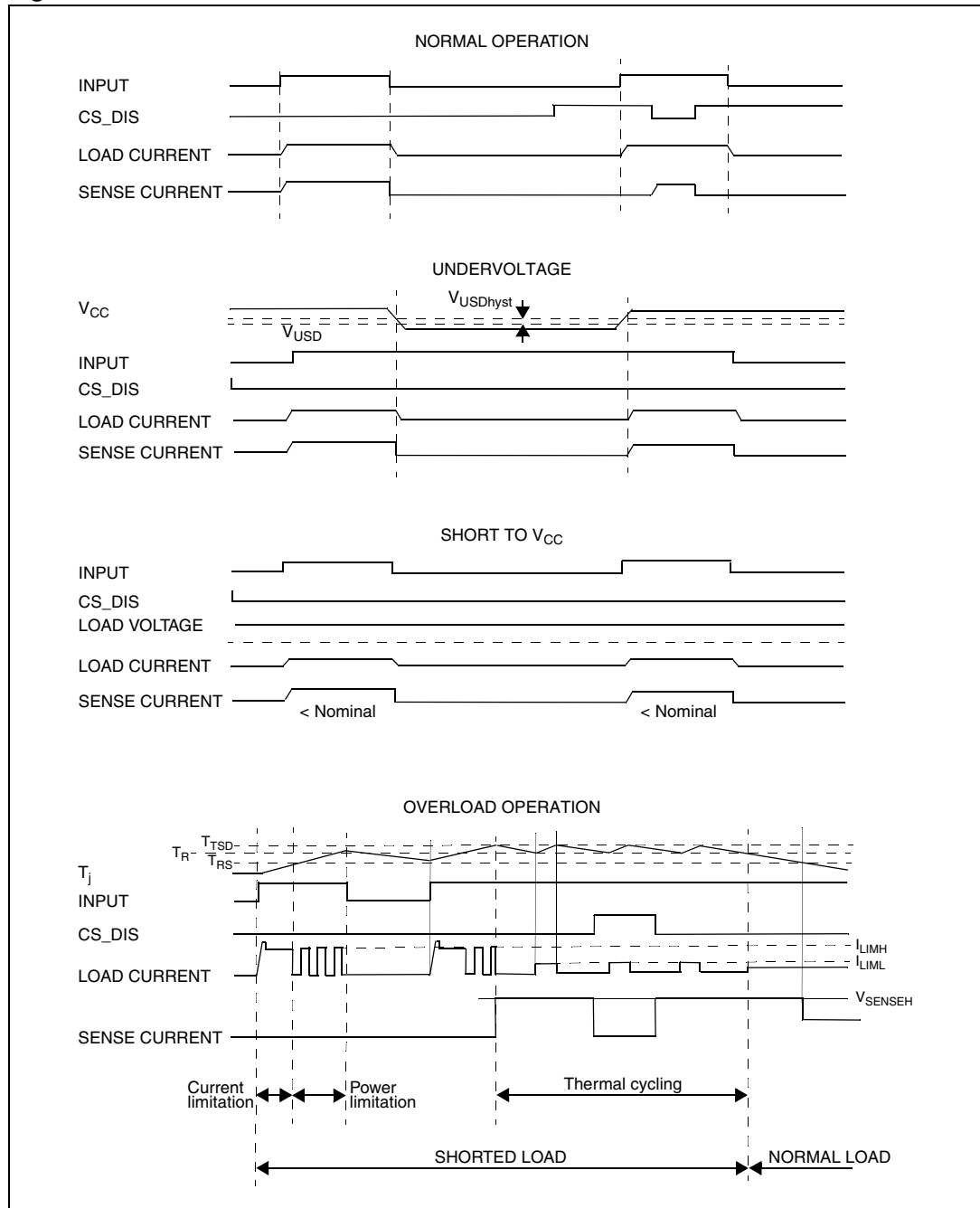

Figure 11. Off state output current

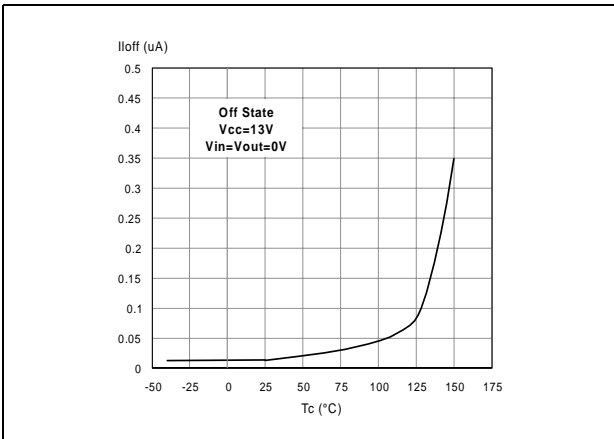

Figure 12. High level input current

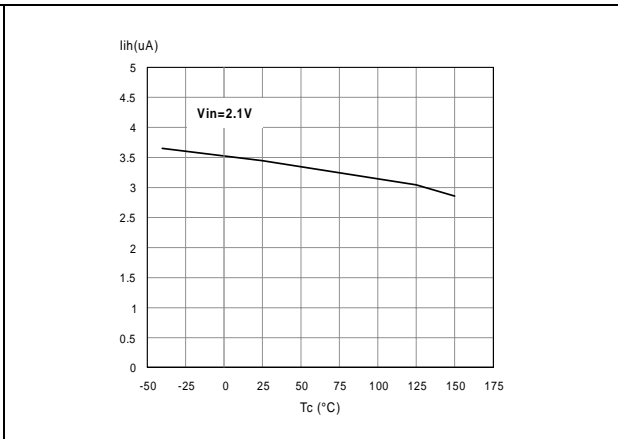

Figure 13. Input clamp voltage

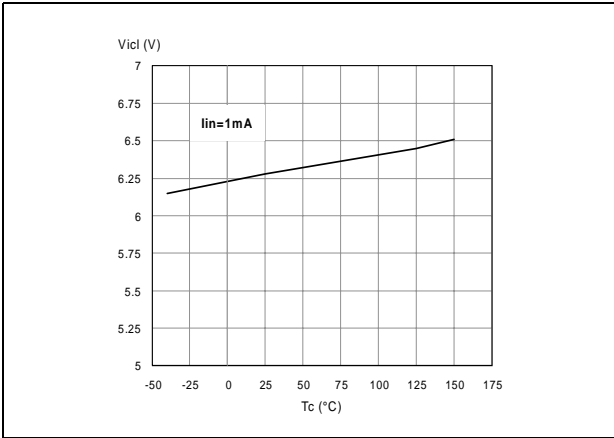

Figure 14. Input high level

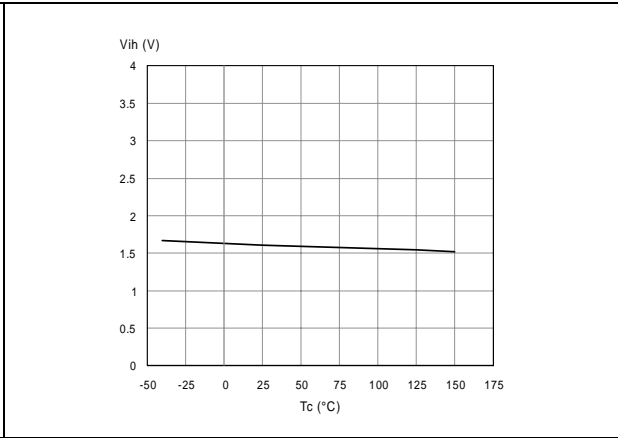

Figure 15. Input low level

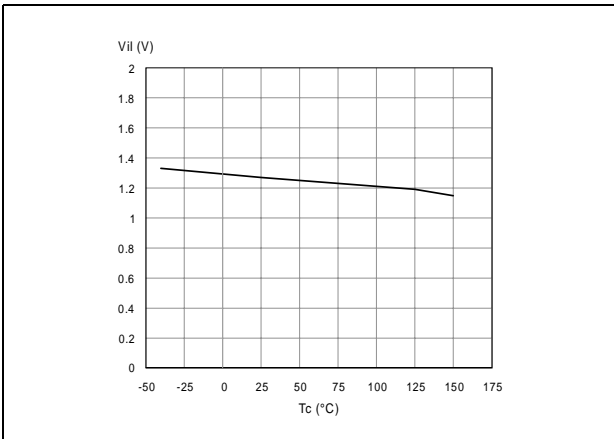

Figure 16. Input hysteresis voltage

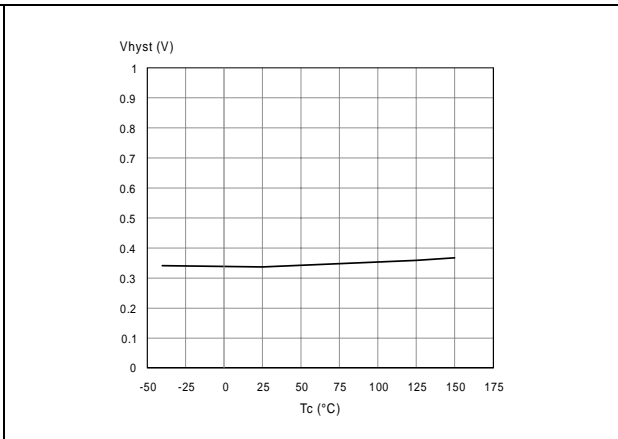

Figure 17. On state resistance vs T_{case}

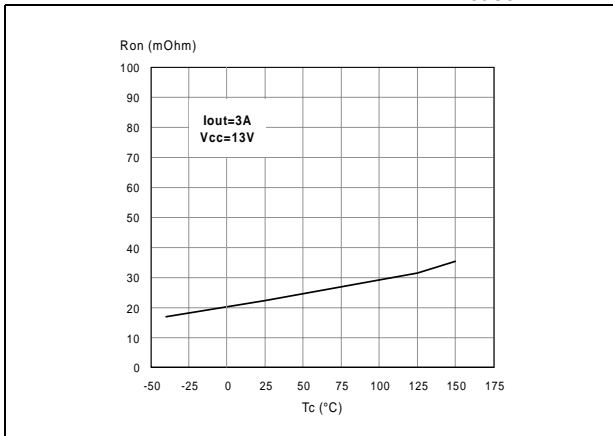

Figure 18. On state resistance vs V_{CC}

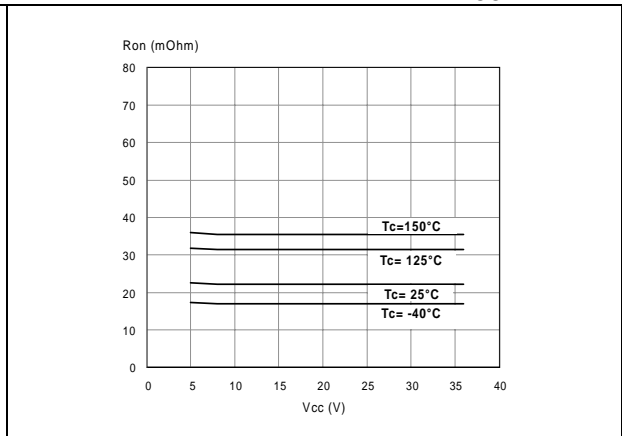

Figure 19. Undervoltage shutdown

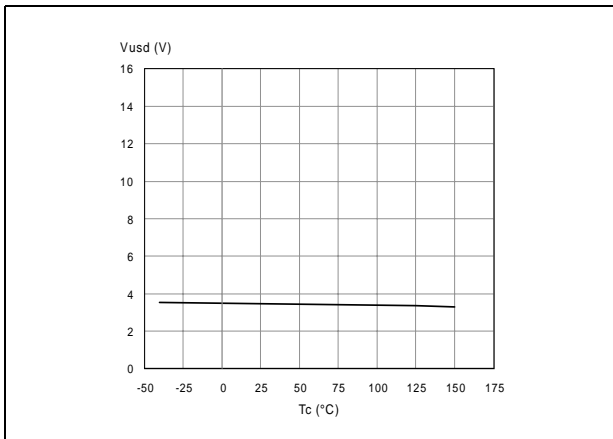

Figure 20. I_{LIMH} vs T_{case}

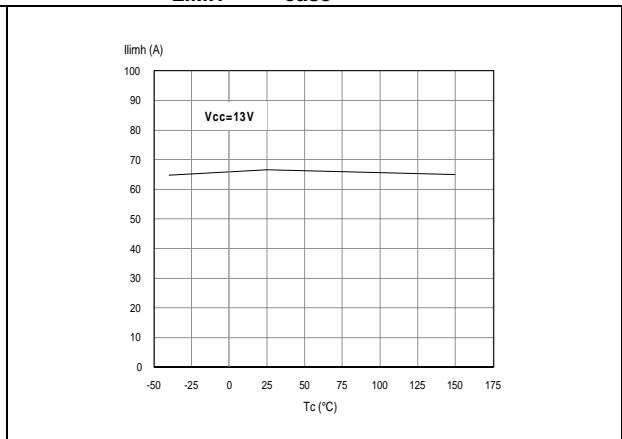

Figure 21. Turn-on voltage slope

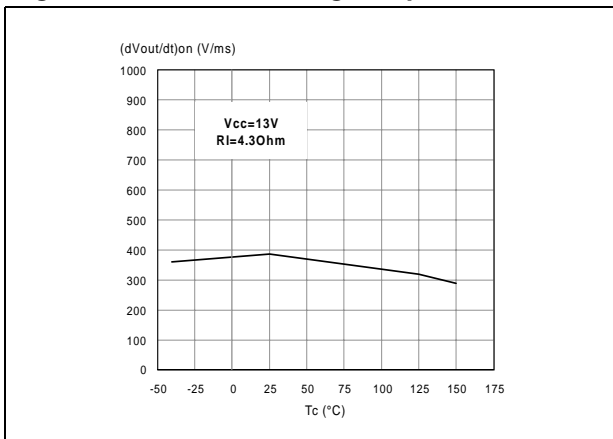

Figure 22. Turn-off voltage slope

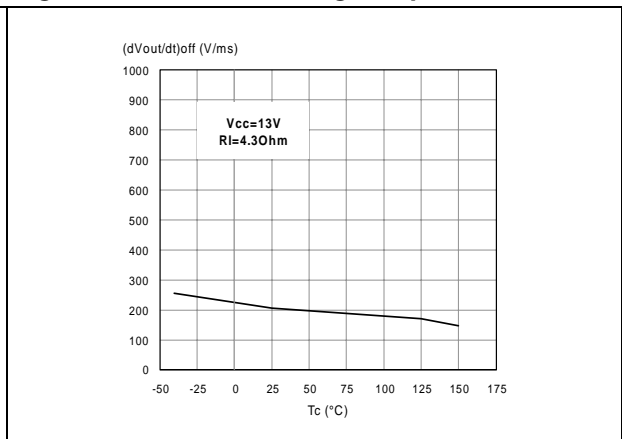

Figure 23. CS_DIS high level voltage

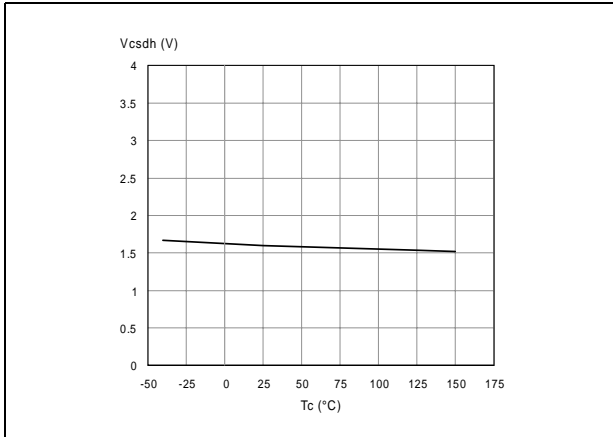

Figure 24. CS_DIS low level voltage

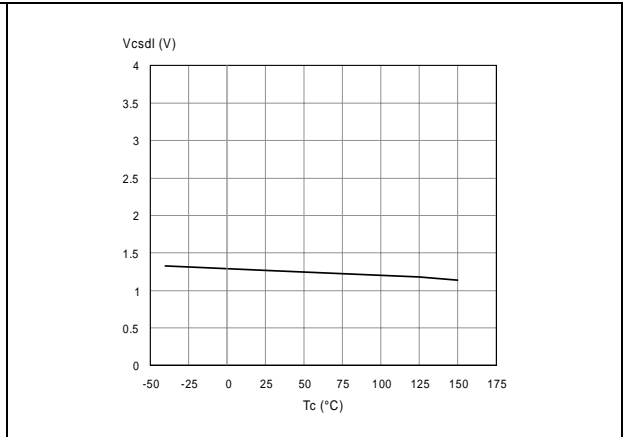
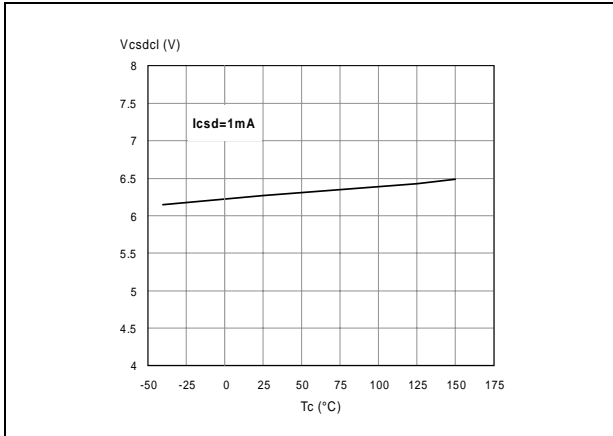
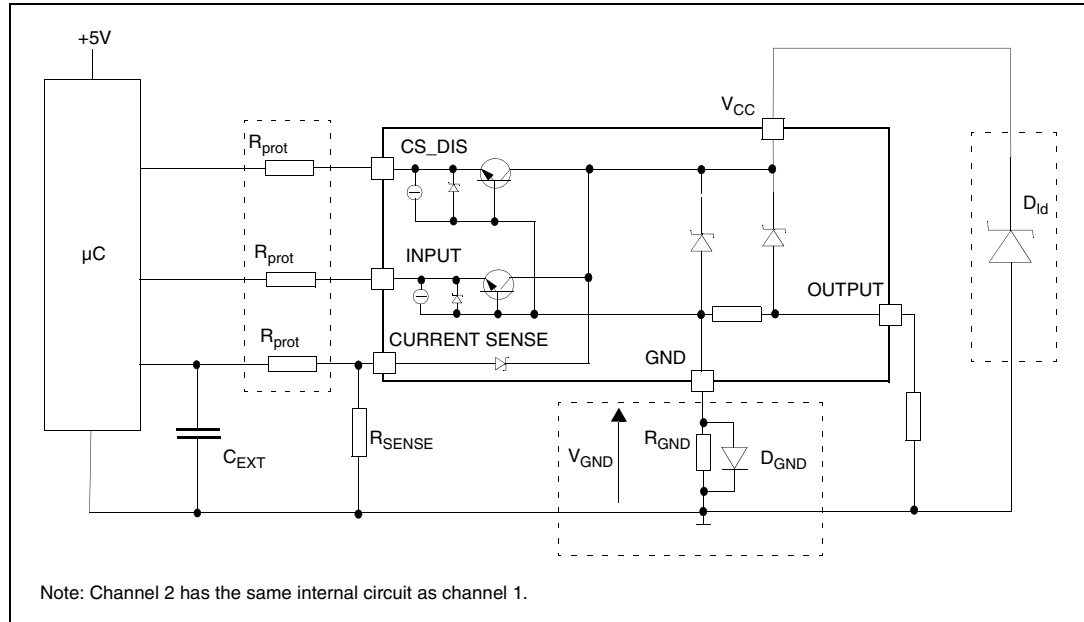

Figure 25. CS_DIS clamp voltage



3 Application information

Figure 26. Application schematic



3.1 GND protection network against reverse battery

This section provides two solutions for implementing a ground protection network against reverse battery.

3.1.1 Solution 1: Resistor in the ground line (R_{GND} only)

This first solution can be used with any type of load.

The following formulas indicate how to dimension the R_{GND} resistor:

1. $R_{GND} \leq 600\text{mV} / (I_{S(on)max})$
2. $R_{GND} \geq (-V_{CC}) / (-I_{GND})$

where -I_{GND} is the DC reverse ground pin current and can be found in the absolute maximum rating section of the device datasheet.

Power Dissipation in R_{GND} (when V_{CC} < 0 during reverse battery situations) is:

$$P_D = (-V_{CC})^2 / R_{GND}$$

This resistor can be shared among several different HSDs. Please note that the value of this resistor is calculated with formula (1), where I_{S(on)max} becomes the sum of the maximum on-state currents of the different devices.

Please note that if the microprocessor ground is not shared by the device ground, the R_{GND} produces a shift (I_{S(on)max} * R_{GND}) in the input thresholds and the status output values. This shift varies depending on how many devices are ON in the case of several high-side drivers sharing the same R_{GND}.

If the calculated power dissipation leads to a large resistor or several devices have to share the same resistor, then ST suggests to utilize the following Solution 2.

3.1.2 Solution 2: Diode (D_{GND}) in the ground line

If the device drives an inductive load, insert a resistor ($R_{GND} = 1k\Omega$) in parallel to D_{GND} .

This small signal diode can be safely shared among several different HSDs. Also in this case, the presence of the ground network produces a shift (j600mV) in the input threshold and in the status output values if the microprocessor ground is not common to the device ground. This shift does not vary if more than one HSD shares the same diode/resistor network.

3.2 Load dump protection

D_{ld} is necessary (Voltage Transient Suppressor) if the load dump peak voltage exceeds the V_{CC} maximum DC rating. The same applies if the device is subject to transients on the V_{CC} line that are greater than the ones shown in the ISO 7637-2:2004E table.

3.3 μC I/Os protection

If a ground protection network is used and negative transients are present on the V_{CC} line, the control pins are pulled negative. ST suggests to insert an in-line resistor (R_{prot}) to prevent the μC I/Os pins from latch-up.

The value of these resistors is a compromise between the leakage current of μC and the current required by the HSD I/Os (input levels compatibility) with the latch-up limit of μC I/Os.

$$-V_{CCpeak}/I_{latchup} \leq R_{prot} \leq (V_{OH\mu C} - V_{IH} - V_{GND}) / I_{IHmax}$$

Calculation example:

$$\text{For } V_{CCpeak} = -100V \text{ and } I_{latchup} \geq 20mA; V_{OH\mu C} \geq 4.5V$$

$$5k\Omega \leq R_{prot} \leq 65k\Omega$$

$$\text{Recommended values: } R_{prot} = 10k\Omega, C_{EXT} = 10nF$$

3.4 Maximum demagnetization energy ($V_{CC} = 13.5V$)

Figure 27. Maximum turn off current versus inductance (for each channel)

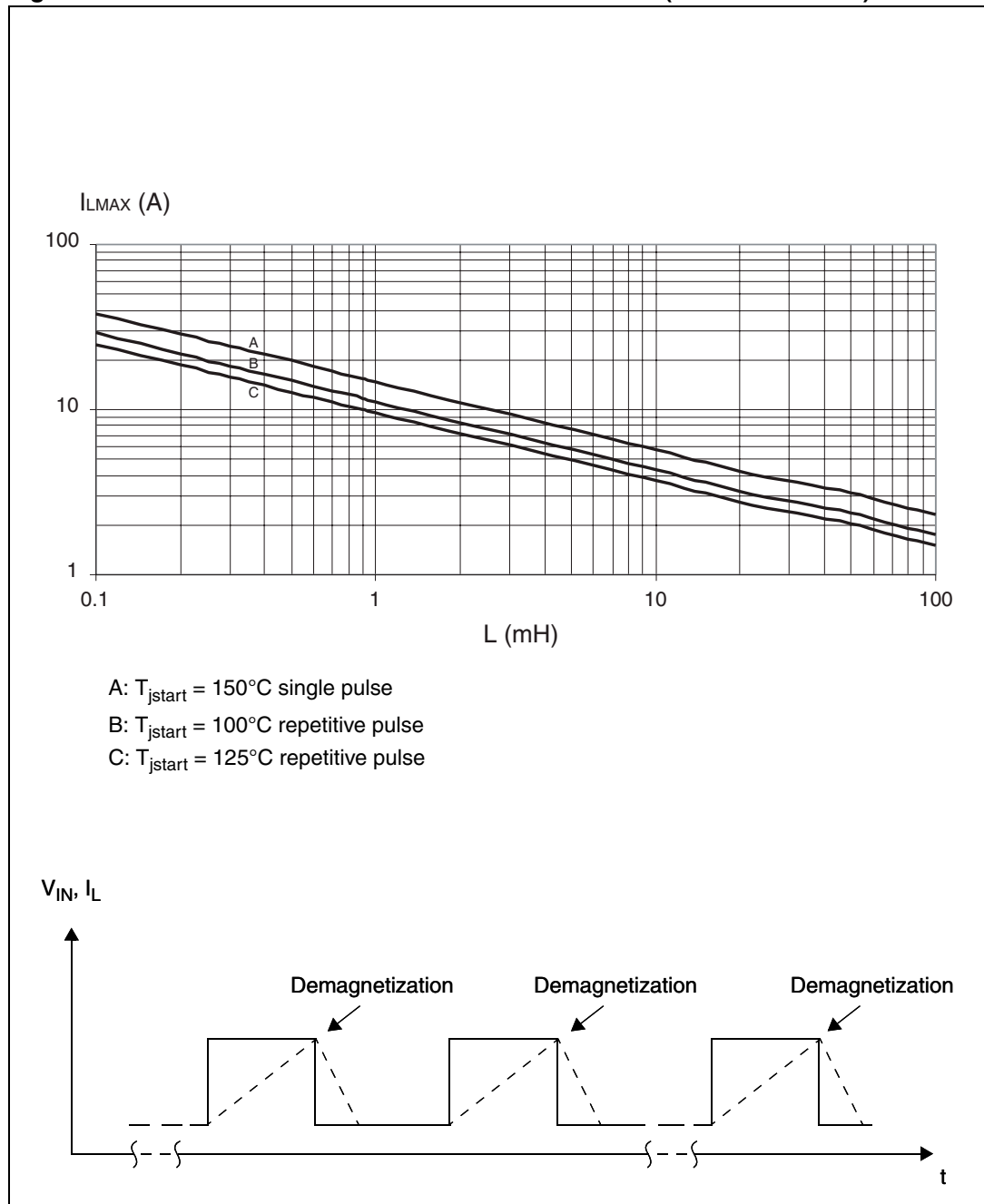

Note: Values are generated with $R_L = 0\Omega$
 In case of repetitive pulses, T_{jstart} (at beginning of each demagnetization) of every pulse must not exceed the temperature specified above for curves A and B.

4 Package and thermal data

4.1 PowerSSO-24™ thermal data

Figure 28. PowerSSO-24™ PC board

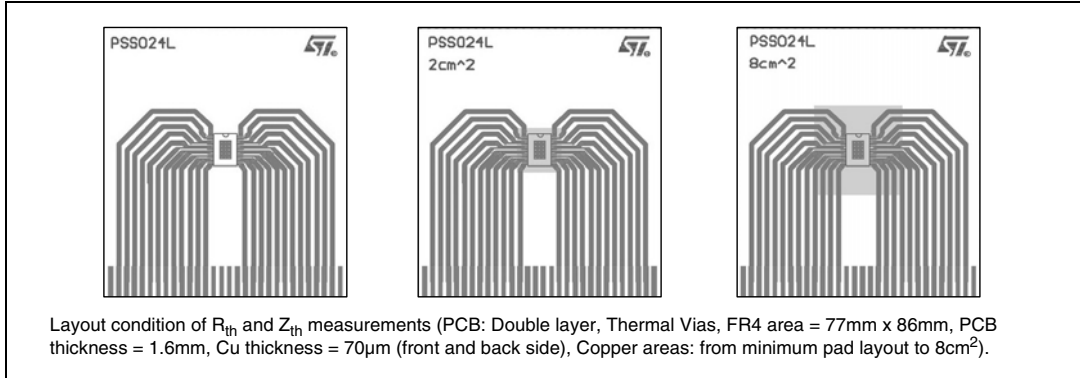

Figure 29. $R_{thj-amb}$ vs PCB copper area in open box free air condition (with one channel ON)

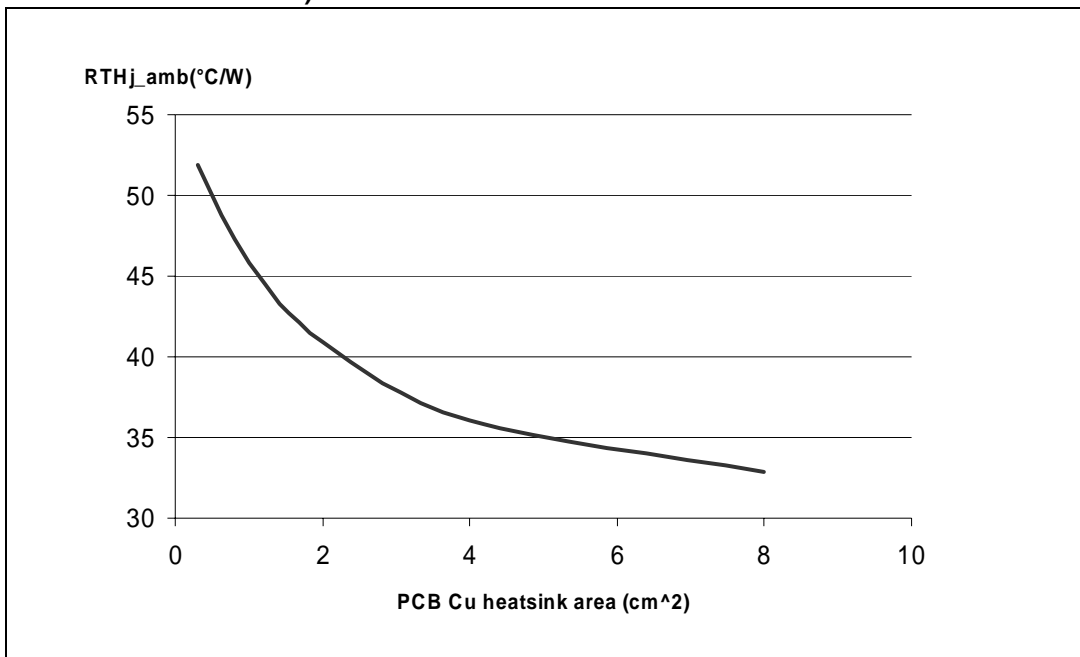

Figure 30. PowerSSO-24™ thermal impedance junction to ambient single pulse (with one channel ON)

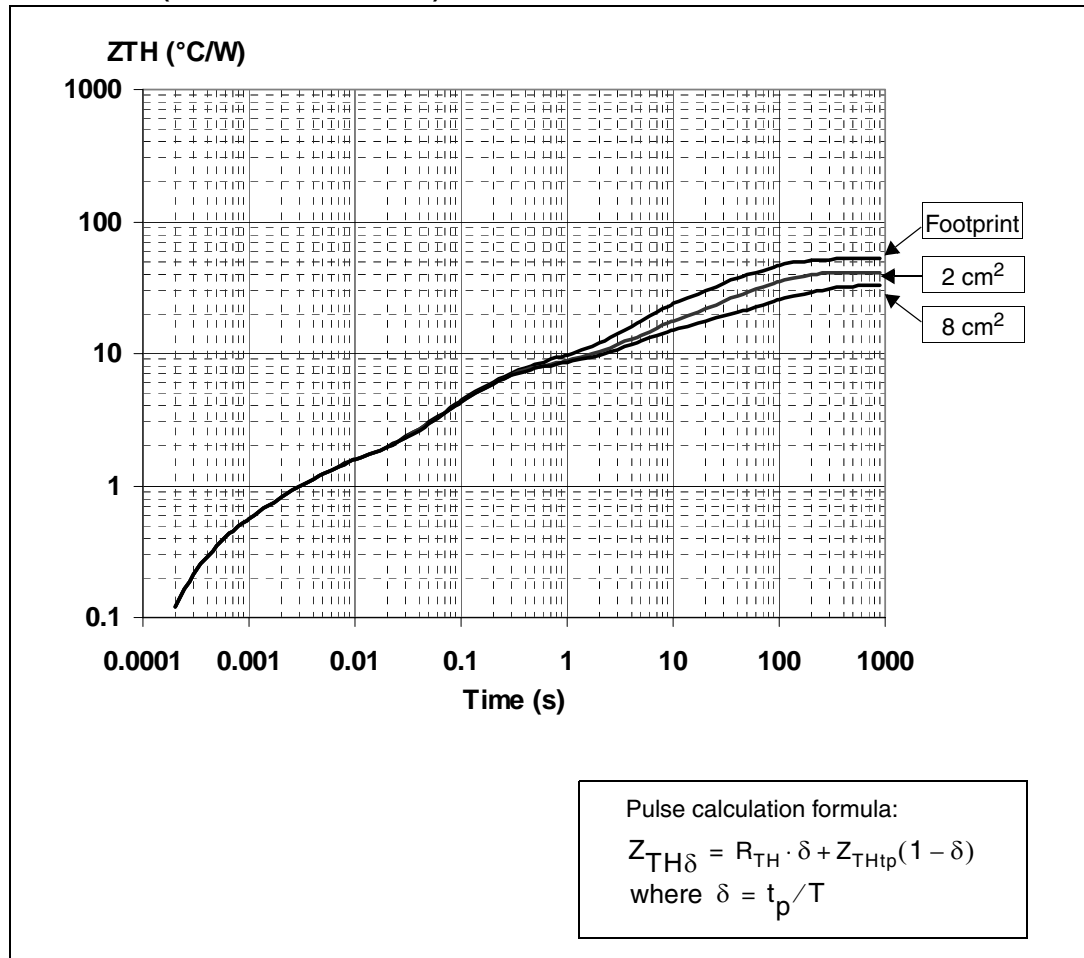
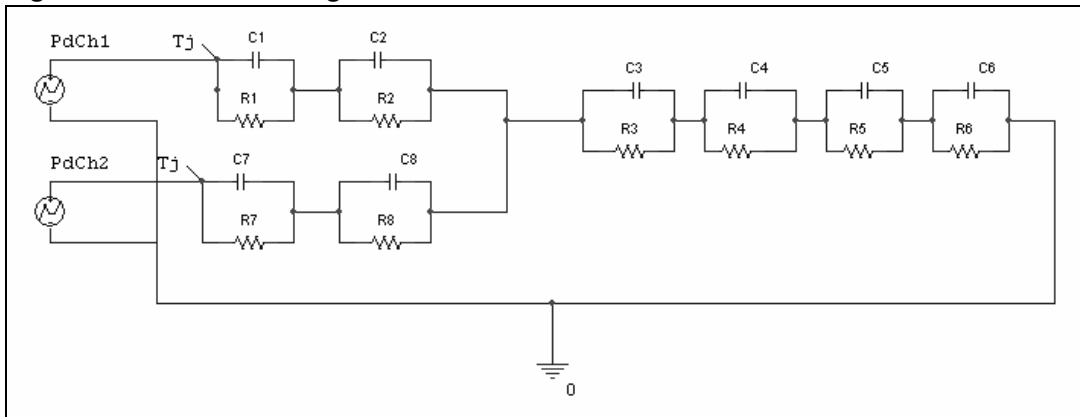

Figure 31. Thermal fitting model of a double channel HSD in PowerSSO-24™(1)



1. Values are given in [Table 12](#)

Table 12. Thermal parameters

Area/Island (cm ²)	Footprint	2	8
R1 (°C/W)	0.28		
R2 (°C/W)	0.9		
R3 (°C/W)	6		
R4 (°C/W)	7.7		
R5 (°C/W)	9	9	8
R6 (°C/W)	28	17	10
R7 (°C/W)	0.28		
R8 (°C/W)	0.9		
C1 (W.s/°C)	0.001		
C2 (W.s/°C)	0.003		
C3 (W.s/°C)	0.025		
C4 (W.s/°C)	0.75		
C5 (W.s/°C)	1	4	9
C6 (W.s/°C)	2.2	5	17
C7 (W.s/°C)	0.001		
C8 (W.s/°C)	0.003		

5 Package and packing information

5.1 ECOPACK[®] packages

In order to meet environmental requirements, ST offers these devices in ECOPACK[®] packages. ECOPACK[®] packages are lead-free. The category of Second Level Interconnect is marked on the package and on the inner box label, in compliance with JEDEC Standard JESD97. The maximum ratings related to soldering conditions are also marked on the inner box label.

ECOPACK is an ST trademark. ECOPACK specifications are available at www.st.com.

5.2 Package mechanical

Table 13. PowerSSO-24[™] mechanical data

Symbol	Millimeters		
	Min	Typ	Max
A	1.9		2.22
A2	1.9		2.15
a1	0		0.07
b	0.34	0.4	0.46
c	0.23		0.32
D	10.2		10.4
E	7.4		7.6
e		0.8	
e3		8.8	
G			0.1
G1			0.06
H	10.1		10.5
h			0.4
L	0.55		0.85
N			10°
X	3.9		4.3
Y	6.1		6.5

Figure 32. PowerSSO-24™ package dimensions

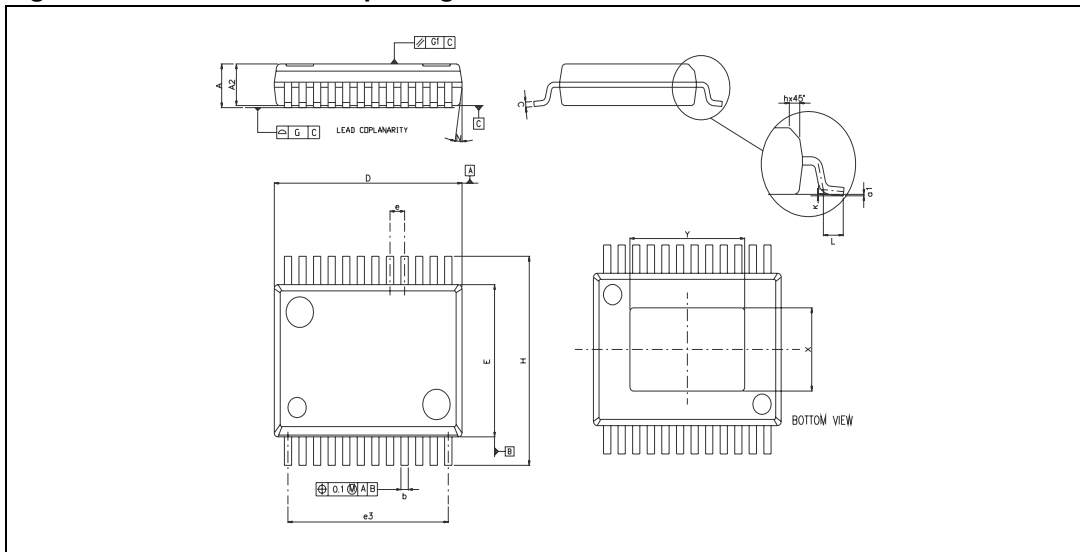

5.3 Packing information

Figure 33. PowerSSO-24™ tube shipment (no suffix)

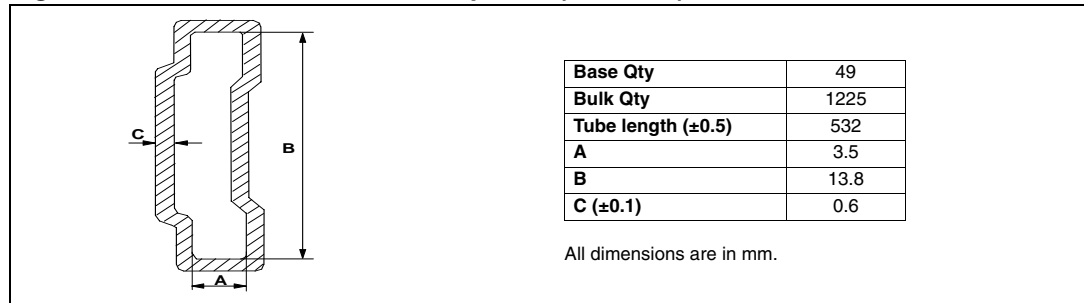
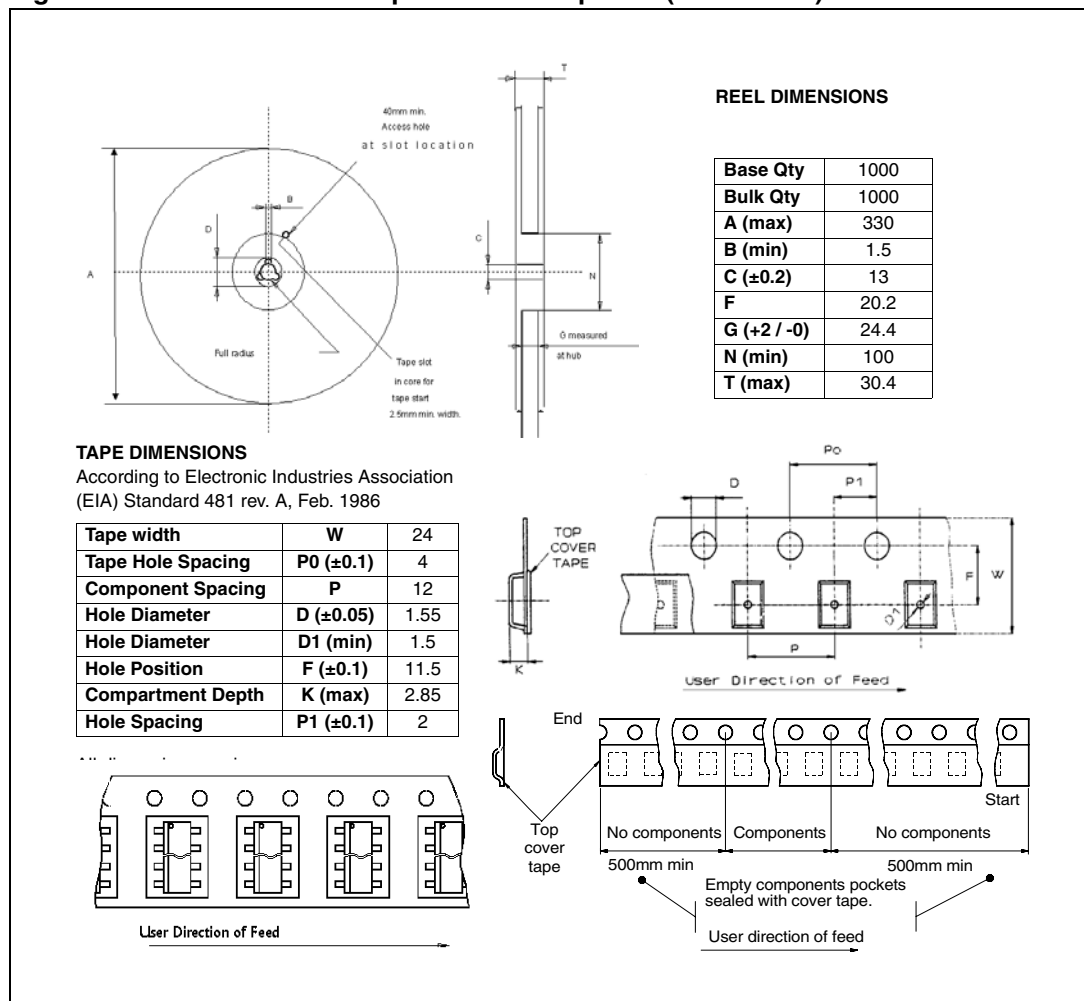

Figure 34. PowerSSO-24™ tape and reel shipment (suffix “TR”)



6 Revision history

Table 14. Document revision history

Date	Revision	Changes
16-Feb-2007	1	Initial release
23-Feb-2007	2	<i>Table 9: Current sense (8V < VCC < 16V)</i> : Error in dK_3/K_3 current sense ratio drift row corrected.
28-Mar-2007	3	<i>Protection</i> section updated to correct editing error.

Please Read Carefully:

Information in this document is provided solely in connection with ST products. STMicroelectronics NV and its subsidiaries ("ST") reserve the right to make changes, corrections, modifications or improvements, to this document, and the products and services described herein at any time, without notice.

All ST products are sold pursuant to ST's terms and conditions of sale.

Purchasers are solely responsible for the choice, selection and use of the ST products and services described herein, and ST assumes no liability whatsoever relating to the choice, selection or use of the ST products and services described herein.

No license, express or implied, by estoppel or otherwise, to any intellectual property rights is granted under this document. If any part of this document refers to any third party products or services it shall not be deemed a license grant by ST for the use of such third party products or services, or any intellectual property contained therein or considered as a warranty covering the use in any manner whatsoever of such third party products or services or any intellectual property contained therein.

UNLESS OTHERWISE SET FORTH IN ST'S TERMS AND CONDITIONS OF SALE ST DISCLAIMS ANY EXPRESS OR IMPLIED WARRANTY WITH RESPECT TO THE USE AND/OR SALE OF ST PRODUCTS INCLUDING WITHOUT LIMITATION IMPLIED WARRANTIES OF MERCHANTABILITY, FITNESS FOR A PARTICULAR PURPOSE (AND THEIR EQUIVALENTS UNDER THE LAWS OF ANY JURISDICTION), OR INFRINGEMENT OF ANY PATENT, COPYRIGHT OR OTHER INTELLECTUAL PROPERTY RIGHT.

UNLESS EXPRESSLY APPROVED IN WRITING BY AN AUTHORIZED ST REPRESENTATIVE, ST PRODUCTS ARE NOT RECOMMENDED, AUTHORIZED OR WARRANTED FOR USE IN MILITARY, AIR CRAFT, SPACE, LIFE SAVING, OR LIFE SUSTAINING APPLICATIONS, NOR IN PRODUCTS OR SYSTEMS WHERE FAILURE OR MALFUNCTION MAY RESULT IN PERSONAL INJURY, DEATH, OR SEVERE PROPERTY OR ENVIRONMENTAL DAMAGE. ST PRODUCTS WHICH ARE NOT SPECIFIED AS "AUTOMOTIVE GRADE" MAY ONLY BE USED IN AUTOMOTIVE APPLICATIONS AT USER'S OWN RISK.

Resale of ST products with provisions different from the statements and/or technical features set forth in this document shall immediately void any warranty granted by ST for the ST product or service described herein and shall not create or extend in any manner whatsoever, any liability of ST.

ST and the ST logo are trademarks or registered trademarks of ST in various countries.

Information in this document supersedes and replaces all information previously supplied.

The ST logo is a registered trademark of STMicroelectronics. All other names are the property of their respective owners.

© 2007 STMicroelectronics - All rights reserved

STMicroelectronics group of companies

Australia - Belgium - Brazil - Canada - China - Czech Republic - Finland - France - Germany - Hong Kong - India - Israel - Italy - Japan - Malaysia - Malta - Morocco - Singapore - Spain - Sweden - Switzerland - United Kingdom - United States of America

www.st.com

