

Single channel high-side driver with analog current sense for automotive applications

Datasheet – production data

Features

Max supply voltage	V_{CC}	41 V
Operating voltage range	V_{CC}	4.5 to 28V
Max on-state resistance	R_{ON}	50 m Ω
Current limitation (typ)	I_{LIMH}	27 A
Off-state supply current	I_S	2 μ A ⁽¹⁾

1. Typical value with all loads connected.

- General
 - Inrush current active management by power limitation
 - Very low standby current
 - 3.0 V CMOS compatible inputs
 - Optimized electromagnetic emissions
 - Very low electromagnetic susceptibility
 - Compliant with European directive 2002/95/EC
 - Very low current sense leakage
 - AEC-Q100 qualified
- Diagnostic functions
 - Proportional load current sense
 - High current sense precision for wide currents range
 - Current sense disable
 - Off-state open-load detection
 - Output short to V_{CC} detection
 - Overload and short to ground (power limitation) indication
 - Thermal shutdown indication
- Protections
 - Undervoltage shutdown
 - Overvoltage clamp
 - Load current limitation
 - Self limiting of fast thermal transients
 - Protection against loss of ground and loss of V_{CC}

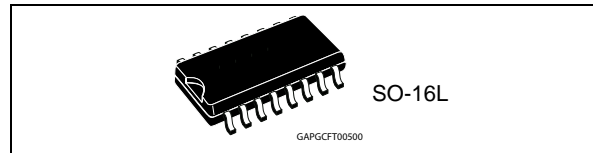

- Overtemperature shutdown with auto restart (thermal shutdown)
- Reverse battery protected
- Electrostatic discharge protection

Application

- All types of resistive, inductive and capacitive loads
- Suitable as LED driver

Description

The VN5E050ASO-E is a single channel high-side driver manufactured using ST proprietary VIPower[®] M0-5 technology and housed in the SO-16L package. The device is designed to drive 12 V automotive grounded loads, and to provide protection and diagnostics. It also implements a 3 V and 5 V CMOS-compatible interface for the use with any microcontroller.

The device integrates advanced protective functions such as load current limitation, inrush and overload active management by power limitation, overtemperature shut-off with auto-restart and overvoltage active clamp. A dedicated analog current sense pin is associated with every output channel providing enhanced diagnostic functions including fast detection of overload and short-circuit to ground through power limitation indication, overtemperature indication, short-circuit to V_{CC} diagnosis and on-state and off-state open-load detection.

The current sensing and diagnostic feedback of the whole device can be disabled by pulling the CS_DIS pin high to share the external sense resistor with similar devices.

Contents

1	Block diagram and pin description	5
2	Electrical specifications	7
2.1	Absolute maximum ratings	7
2.2	Thermal data	8
2.3	Electrical characteristics	8
2.4	Waveforms	18
2.5	Electrical characteristics curves	21
3	Application information	24
3.1	GND protection network against reverse battery	24
3.1.1	Solution 1: resistor in the ground line (RGND only)	24
3.1.2	Solution 2: diode (D _{GND}) in the ground line	25
3.2	Load dump protection	25
3.3	MCU I/O protection	25
3.4	Current sense and diagnostic	25
3.4.1	Short to VCC and off-state open-load detection	26
3.5	Maximum demagnetization energy (VCC = 13.5V)	28
4	Package and PCB thermal data	29
4.1	SO-16L thermal data	29
5	Package information	32
5.1	ECOPACK [®] packages	32
5.2	Package mechanical data	32
5.3	Packing information	34
6	Order codes	35
7	Revision history	36

List of tables

Table 1.	Pin function	5
Table 2.	Suggested connections for unused and not connected pins	6
Table 3.	Absolute maximum ratings	7
Table 4.	Thermal data	8
Table 5.	Power section	8
Table 6.	Switching ($V_{CC} = 13\text{ V}$; $T_j = 25\text{ °C}$)	9
Table 7.	Logic inputs	9
Table 8.	Protections and diagnostics	10
Table 9.	Current sense ($8\text{ V} < V_{CC} < 18\text{ V}$)	10
Table 10.	Open-load detection ($8\text{ V} < V_{CC} < 18\text{ V}$)	12
Table 11.	Truth table	16
Table 12.	Electrical transient requirements (part 1)	17
Table 13.	Electrical transient requirements (part 2)	17
Table 14.	Electrical transient requirements (part 3)	17
Table 15.	Thermal parameter	31
Table 16.	SO-16L mechanical data	33
Table 17.	Device summary	35
Table 18.	Document revision history	36

List of figures

Figure 1.	Block diagram	5
Figure 2.	Configuration diagram (top view)	6
Figure 3.	Current and voltage conventions	7
Figure 4.	Current sense delay characteristics	12
Figure 5.	Open-load off-state delay timing	13
Figure 6.	Switching characteristics	13
Figure 7.	Delay response time between rising edge of output current and rising edge of current sense (CS enabled)	14
Figure 8.	Output voltage drop limitation	14
Figure 9.	I_{OUT}/I_{SENSE} vs I_{OUT}	15
Figure 10.	Maximum current sense ratio drift vs load current	15
Figure 11.	Normal operation	18
Figure 12.	Overload or short to GND	18
Figure 13.	Intermittent overload	19
Figure 14.	Off-state open-load with external circuitry	19
Figure 15.	Short to V_{CC}	20
Figure 16.	T_j evolution in over load or short to GND	20
Figure 17.	Off-state output current	21
Figure 18.	High level input current	21
Figure 19.	Input clamp level	21
Figure 20.	Input low level	21
Figure 21.	Input high level	21
Figure 22.	Input hysteresis voltage	21
Figure 23.	On-state resistance vs T_{case}	22
Figure 24.	On-state resistance vs V_{CC}	22
Figure 25.	Undervoltage shutdown	22
Figure 26.	Turn-On voltage slope	22
Figure 27.	I_{LIMH} vs T_{case}	22
Figure 28.	Turn-Off voltage slope	22
Figure 29.	CS_DIS high level voltage	23
Figure 30.	CS_DIS clamp voltage	23
Figure 31.	CS_DIS low level voltage	23
Figure 32.	Application schematic	24
Figure 33.	Current sense and diagnostic	26
Figure 34.	Maximum turn-Off current versus inductance	28
Figure 35.	SO-16L PC board	29
Figure 36.	$R_{thj-amb}$ vs PCB copper area in open box free air condition	29
Figure 37.	SO-16L thermal impedance junction ambient single pulse	30
Figure 38.	Thermal fitting model of a single channel HSD in SO-16L	30
Figure 39.	SO-16L package dimensions	32
Figure 40.	SO-16L tube shipment (no suffix)	34
Figure 41.	SO-16L tape and reel shipment (suffix "TR")	34

1 Block diagram and pin description

Figure 1. Block diagram

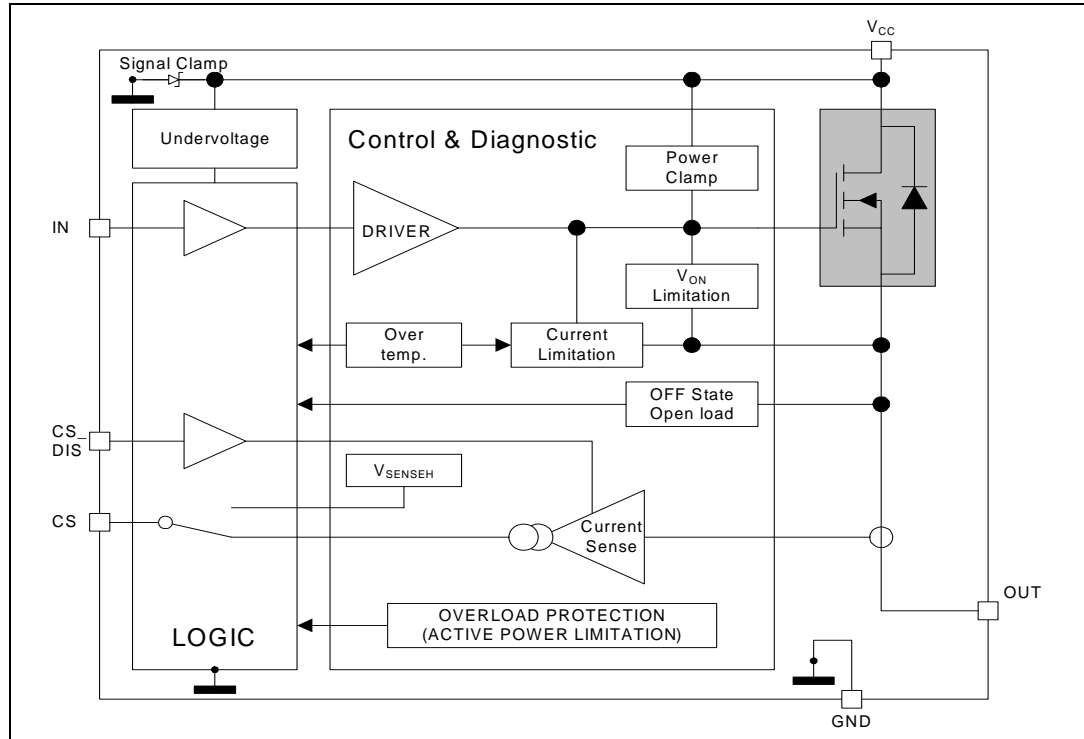

Table 1. Pin function

Name	Function
V _{CC}	Battery connection.
OUTPUT	Power output.
GND	Ground connection. Must be reverse battery protected by an external diode/resistor network.
INPUT	Voltage controlled input pin with hysteresis, CMOS compatible; it controls output switch state.
CURRENT SENSE	Analog current sense pin; it delivers a current proportional to the load current.
CS_DIS	Active high CMOS compatible pin, to disable the current sense pin.

Figure 2. Configuration diagram (top view)

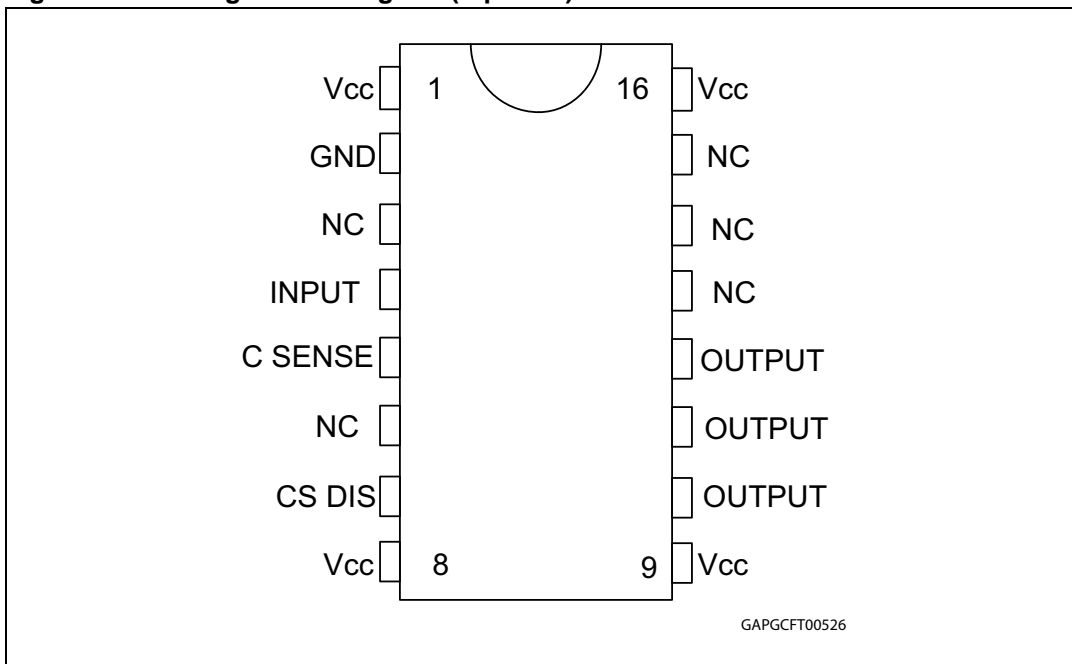
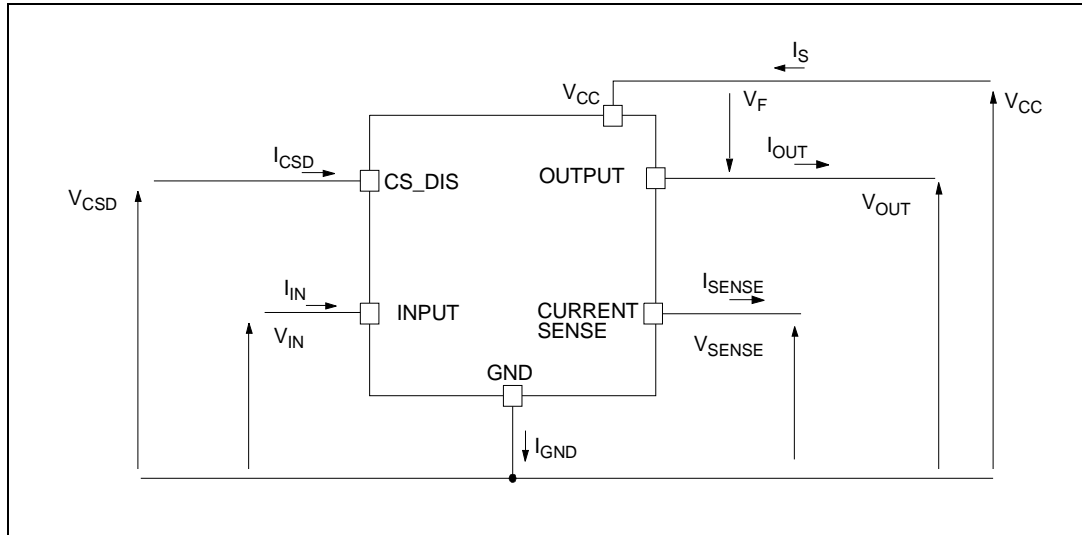

Table 2. Suggested connections for unused and not connected pins

Connection / pin	Current sense	N.C.	Output	Input	CS_DIS
Floating	Not allowed	X	X	X	X
To ground	Through 1 KΩ resistor	X	Through 22 KΩ resistor	Through 10 KΩ resistor	Through 10 KΩ resistor

2 Electrical specifications

Figure 3. Current and voltage conventions



Note: $V_F = V_{OUT} - V_{CC}$ during reverse battery condition.

2.1 Absolute maximum ratings

Stressing the device above the rating listed in [Table 3](#) may cause permanent damage to the device. These are stress ratings only and operation of the device at these or any other conditions above those indicated in the Operating sections of this specification is not implied. Exposure to Absolute Maximum Rating conditions for extended periods may affect device reliability.

Table 3. Absolute maximum ratings

Symbol	Parameter	Value	Unit
V_{CC}	DC supply voltage	41	V
$-V_{CC}$	Reverse DC supply voltage	0.3	V
$-I_{GND}$	DC reverse ground pin current	200	mA
I_{OUT}	DC output current	Internally limited	A
$-I_{OUT}$	Reverse DC output current	20	A
I_{IN}	DC input current	-1 to 10	mA
I_{CS_D}	DC current sense disable input current	-1 to 10	mA
$-I_{CS_{SENSE}}$	DC reverse CS pin current	200	mA
$V_{CS_{SENSE}}$	Current sense maximum voltage	$V_{CC} - 41$ to $+V_{CC}$	V
E_{MAX}	Maximum switching energy (single pulse) $L = 3 \text{ mH}; R_L = 0 \Omega; V_{bat} = 13.5 \text{ V}; T_{jstart} = 150^\circ\text{C}; I_{OUT} = I_{limL} (Typ.)$	104	mJ

Table 3. Absolute maximum ratings (continued)

Symbol	Parameter	Value	Unit
V _{ESD}	Electrostatic discharge (Human Body Model: R = 1.5 KΩ; C = 100 pF)		
	- INPUT	4000	V
	- CURRENT SENSE	2000	V
	- CS_DIS	4000	V
	- OUTPUT	5000	V
	- V _{CC}	5000	V
V _{ESD}	Charge device model (CDM-AEC-Q100-011)	750	V
T _j	Junction operating temperature	-40 to 150	°C
T _{stg}	Storage temperature	-55 to 150	°C

2.2 Thermal data

Table 4. Thermal data

Symbol	Parameter	Typ. value	Unit
R _{thj-pcb}	Thermal resistance junction-pcb ⁽¹⁾	18.5	°C/W
R _{thj-amb}	Thermal resistance junction - ambient on two layers pcb	See Figure 36	°C/W
R _{thj-amb}	Thermal resistance junction - ambient on two layers pcb ⁽²⁾	34.5	°C/W

1. The measure is done in accordance with the JESD 51-8.

2. Four Layers PCB characteristics:

- Cu thickness: 70 um outer layers, 35 um inner layers
- Board finish thickness 1.6 mm +/- 10%
- Thermal vias separation 1.2 mm
- Thermal via diameter 0.3 mm +/- 0.08 mm
- Cu thickness on vias 0.025 mm
- Device soldered at about 2 cm from the PCB edge with two sqcm of exposed copper.

2.3 Electrical characteristics

Values specified in this section are for 8 V < V_{CC} < 28 V; -40°C < T_j < 150°C, unless otherwise stated.

Table 5. Power section

Symbol	Parameter	Test conditions	Min.	Typ.	Max.	Unit
V _{CC}	Operating supply voltage		4.5	13	28	V
V _{USD}	Undervoltage shutdown			3.5	4.5	V
V _{USDhyst}	Undervoltage shutdown hysteresis			0.5		V

Table 5. Power section (continued)

Symbol	Parameter	Test conditions	Min.	Typ.	Max.	Unit
R _{ON}	On-state resistance	I _{OUT} = 2 A; T _j = 25°C		50		mΩ
		I _{OUT} = 2 A; T _j = 150°C			100	mΩ
		I _{OUT} = 2 A; V _{CC} = 5 V; T _j = 25°C			65	mΩ
V _{clamp}	Clamp voltage	I _S = 20 mA	41	46	52	V
I _S	Supply current	Off-state; V _{CC} = 13 V; T _j = 25°C; V _{IN} = V _{OUT} = V _{SENSE} = V _{CSD} = 0 V		2 ⁽¹⁾	5 ⁽¹⁾	μA
		On-state; V _{CC} = 13 V; V _{IN} = 5 V; I _{OUT} = 0 A		1.5	3	mA
I _{L(off1)}	Off-state output current	V _{IN} = V _{OUT} = 0 V; V _{CC} = 13 V; T _j = 25°C	0	0.01	3	μA
		V _{IN} = V _{OUT} = 0 V; V _{CC} = 13 V; T _j = 125°C	0		5	μA
V _F	Output - V _{CC} diode voltage	-I _{OUT} = 2 A; T _j = 150°C			0.7	V

1. PowerMOS leakage included.

Table 6. Switching (V_{CC} = 13 V; T_j = 25 °C)

Symbol	Parameter	Test conditions	Min.	Typ.	Max.	Unit
t _{d(on)}	Turn-on delay time	R _L = 6.5 Ω (see Figure 6)	—	20	—	μs
t _{d(off)}	Turn-off delay time	R _L = 6.5 Ω (see Figure 6)	—	40	—	μs
(dV _{OUT} /dt) _{on}	Turn-on voltage slope	R _L = 6.5 Ω	—	See Figure 26	—	V/μs
(dV _{OUT} /dt) _{off}	Turn-off voltage slope	R _L = 6.5 Ω	—	See Figure 28	—	V/μs
W _{ON}	Switching energy losses during t _{on}	R _L = 6.5 Ω (see Figure 6)	—	0.20	—	mJ
W _{OFF}	Switching energy losses during t _{off}	R _L = 6.5 Ω (see Figure 6)	—	0.3	—	mJ

Table 7. Logic inputs

Symbol	Parameter	Test conditions	Min.	Typ.	Max.	Unit
V _{IL}	Input low level voltage				0.9	V
I _{IL}	Low level input current	V _{IN} = 0.9 V	1			μA
V _{IH}	Input high level voltage		2.1			V
I _{IH}	High level input current	V _{IN} = 2.1 V			10	μA
V _{I(hyst)}	Input hysteresis voltage		0.25			V
V _{ICL}	Input clamp voltage	I _{IN} = 1 mA	5.5		7	V
		I _{IN} = -1 mA		-0.7		V

Table 7. Logic inputs (continued)

Symbol	Parameter	Test conditions	Min.	Typ.	Max.	Unit
V_{CSDL}	CS_DIS low level voltage				0.9	V
I_{CSDL}	Low level CS_DIS current	$V_{CSD} = 0.9\text{ V}$	1			μA
V_{CSDH}	CS_DIS high level voltage		2.1			V
I_{CSDH}	High level CS_DIS current	$V_{CSD} = 2.1\text{ V}$			10	μA
$V_{CSD(hyst)}$	CS_DIS hysteresis voltage		0.25			V
V_{CSCL}	CS_DIS clamp voltage	$I_{CSD} = 1\text{ mA}$	5.5		7	V
		$I_{CSD} = -1\text{ mA}$		-0.7		V

Table 8. Protections and diagnostics (1)

Symbol	Parameter	Test conditions	Min.	Typ.	Max.	Unit
I_{limH}	DC short circuit current	$V_{CC} = 13\text{ V}$	19	27	38	A
		$5\text{ V} < V_{CC} < 28\text{ V}$			38	A
I_{limL}	Short circuit current during thermal cycling	$V_{CC} = 13\text{ V}; T_R < T_J < T_{TSD}$		7		A
T_{TSD}	Shutdown temperature		150	175	200	$^{\circ}\text{C}$
T_R	Reset temperature		$T_{RS} + 1$	$T_{RS} + 5$		$^{\circ}\text{C}$
T_{RS}	Thermal reset of status		135			$^{\circ}\text{C}$
T_{HYST}	Thermal hysteresis ($T_{TSD} - T_R$)			7		$^{\circ}\text{C}$
V_{DEMAG}	Turn- Off output voltage clamp	$I_{OUT} = 2\text{ A}; V_{IN} = 0;$ $L = 6\text{ mH}$	$V_{CC}-41$	$V_{CC}-46$	$V_{CC}-52$	V
V_{ON}	Output voltage drop limitation	$I_{OUT} = 0.1\text{ A};$ $T_J = -40^{\circ}\text{C}$ to 150°C (see Figure 8)		25		mV

1. To ensure long term reliability under heavy overload or short circuit conditions, protection and related diagnostic signals must be used together with a proper software strategy. If the device is subjected to abnormal conditions, this software must limit the duration and number of activation cycles.

Table 9. Current sense ($8\text{ V} < V_{CC} < 18\text{ V}$)

Symbol	Parameter	Test conditions	Min.	Typ.	Max.	Unit
K_0	I_{OUT}/I_{SENSE}	$I_{OUT} = 0.05\text{ A}; V_{SENSE} = 0.5\text{ V};$ $V_{CSD} = 0\text{ V}; T_J = -40^{\circ}\text{C}$ to 150°C	1170	2000	3090	
K_1	I_{OUT}/I_{SENSE}	$I_{OUT} = 1\text{ A}; V_{SENSE} = 4\text{ V};$ $V_{CSD} = 0\text{ V};$ $T_J = -40^{\circ}\text{C}$ to 150°C	1575	2000	2750	
		$T_J = 25^{\circ}\text{C}$ to 150°C	1575	2000	2465	
$dK_1/K_1^{(1)}$	Current sense ratio drift	$I_{OUT} = 1\text{ A}; V_{SENSE} = 4\text{ V};$ $V_{CSD} = 0\text{ V};$ $T_J = -40^{\circ}\text{C}$ to 150°C	-10		10	%

Table 9. Current sense ($8\text{ V} < V_{CC} < 18\text{ V}$) (continued)

Symbol	Parameter	Test conditions	Min.	Typ.	Max.	Unit
K_2	I_{OUT}/I_{SENSE}	$I_{OUT} = 2\text{ A}; V_{SENSE} = 4\text{ V};$ $V_{CSD} = 0\text{ V};$ $T_j = -40^\circ\text{C to } 150^\circ\text{C}$ $T_j = 25^\circ\text{C to } 150^\circ\text{C}$	1765 1765	2000 2000	2315 2155	
$dK_2/K_2^{(1)}$	Current sense ratio drift	$I_{OUT} = 2\text{ A}; V_{SENSE} = 4\text{ V};$ $V_{CSD} = 0\text{ V};$ $T_j = -40^\circ\text{C to } 150^\circ\text{C}$	-7		7	%
K_3	I_{OUT}/I_{SENSE}	$I_{OUT} = 4\text{ A}; V_{SENSE} = 4\text{ V};$ $V_{CSD} = 0\text{ V};$ $T_j = -40^\circ\text{C to } 150^\circ\text{C}$ $T_j = 25^\circ\text{C to } 150^\circ\text{C}$	1840 1840	2000 2000	2135 2080	
$dK_3/K_3^{(1)}$	Current sense ratio drift	$I_{OUT} = 4\text{ A}; V_{SENSE} = 4\text{ V};$ $V_{CSD} = 0\text{ V};$ $T_j = -40^\circ\text{C to } 150^\circ\text{C}$	-4		4	%
I_{SENSE0}	Analog sense leakage current	$I_{OUT} = 0\text{ A}; V_{SENSE} = 0\text{ V};$ $V_{CSD} = 5\text{ V}; V_{IN} = 0\text{ V};$ $T_j = -40^\circ\text{C to } 150^\circ\text{C}$	0		1	μA
		$V_{CSD} = 0\text{ V}; V_{IN} = 5\text{ V};$ $T_j = -40^\circ\text{C to } 150^\circ\text{C}$	0		2	μA
		$I_{OUT} = 2\text{ A}; V_{SENSE} = 0\text{ V};$ $V_{CSD} = 5\text{ V}; V_{IN} = 5\text{ V};$ $T_j = -40^\circ\text{C to } 150^\circ\text{C}$	0		1	μA
I_{OL}	Open-load on-state current detection threshold	$V_{IN} = 5\text{ V}; 8\text{ V} < V_{CC} < 18\text{ V};$ $I_{SENSE} = 5\text{ }\mu\text{A}$	4		20	mA
V_{SENSE}	Max analog sense output voltage	$I_{OUT} = 4\text{ A}; V_{CSD} = 0\text{ V}$	5			V
V_{SENSEH}	Analog sense output voltage in fault condition ⁽²⁾	$V_{CC} = 13\text{ V}; R_{SENSE} = 3.9\text{ k}\Omega$		8		V
I_{SENSEH}	Analog sense output current in fault condition ⁽²⁾	$V_{CC} = 13\text{ V}; V_{SENSE} = 5\text{ V}$		9		mA
$t_{DSENSE1H}$	Delay response time from falling edge of CS_DIS pin	$V_{SENSE} < 4\text{ V};$ $0.5\text{ A} < I_{OUT} < 4\text{ A};$ $I_{SENSE} = 90\%$ of $I_{SENSE\text{ max}}$ (see Figure 4)		50	100	μs
$t_{DSENSE1L}$	Delay response time from rising edge of CS_DIS pin	$V_{SENSE} < 4\text{ V};$ $0.5\text{ A} < I_{OUT} < 4\text{ A};$ $I_{SENSE} = 10\%$ of $I_{SENSE\text{ max}}$ (see Figure 4)		5	20	μs
$t_{DSENSE2H}$	Delay response time from rising edge of INPUT pin	$V_{SENSE} < 4\text{ V};$ $0.5\text{ A} < I_{OUT} < 4\text{ A};$ $I_{SENSE} = 90\%$ of $I_{SENSE\text{ max}}$ (see Figure 4)		80	250	μs

Table 9. Current sense (8 V < V_{CC} < 18 V) (continued)

Symbol	Parameter	Test conditions	Min.	Typ.	Max.	Unit
$\Delta t_{\text{DSSENSE2H}}$	Delay response time between rising edge of output current and rising edge of current sense	$V_{\text{SENSE}} < 4 \text{ V}$; $I_{\text{SENSE}} = 90\% \text{ of } I_{\text{SENSEMAX}}$; $I_{\text{OUT}} = 90\% \text{ of } I_{\text{OUTMAX}}$; $I_{\text{OUTMAX}} = 2 \text{ A}$ (see Figure 7)			40	μs
$t_{\text{DSSENSE2L}}$	Delay response time from falling edge of INPUT pin	$V_{\text{SENSE}} < 4 \text{ V}$; $0.5 \text{ A} < I_{\text{OUT}} < 4 \text{ A}$; $I_{\text{SENSE}} = 10\% \text{ of } I_{\text{SENSE max}}$ (see Figure 4)		100	250	μs

1. Parameter guaranteed by design; it is not tested.
2. Fault condition includes: power limitation, overtemperature and open-load off-state detection.

Table 10. Open-load detection (8 V < V_{CC} < 18 V)

Symbol	Parameter	Test conditions	Min.	Typ.	Max.	Unit
V_{OL}	Open-load off-state voltage detection threshold	$V_{\text{IN}} = 0 \text{ V}$	2	See Figure 5	4	V
t_{DSTKON}	Output short circuit to V _{CC} detection delay at turn Off	See Figure 5	180		1200	μs
$I_{\text{L(off2)r}}$	Off-state output current at $V_{\text{OUT}} = 4 \text{ V}$	$V_{\text{IN}} = 0 \text{ V}$; $V_{\text{SENSE}} = 0 \text{ V}$; V_{OUT} rising from 0 V to 4 V	-120		0	μA
$I_{\text{L(off2)f}}$	Off-state output current at $V_{\text{OUT}} = 2 \text{ V}$	$V_{\text{IN}} = 0 \text{ V}$; $V_{\text{SENSE}} = V_{\text{SENSEH}}$; V_{OUT} falling from V _{CC} to 2 V	-50		90	μA
$t_{\text{d_vol}}$	Delay response from output rising edge to V _{SENSE} rising edge in open-load	$V_{\text{OUT}} = 4 \text{ V}$; $V_{\text{IN}} = 0 \text{ V}$; $V_{\text{SENSE}} = 90\% \text{ of } V_{\text{SENSEH}}$			20	μs

Figure 4. Current sense delay characteristics

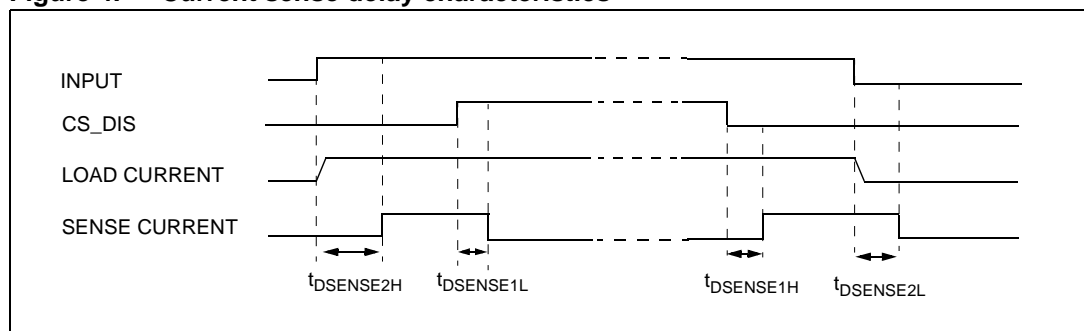

Figure 5. Open-load off-state delay timing

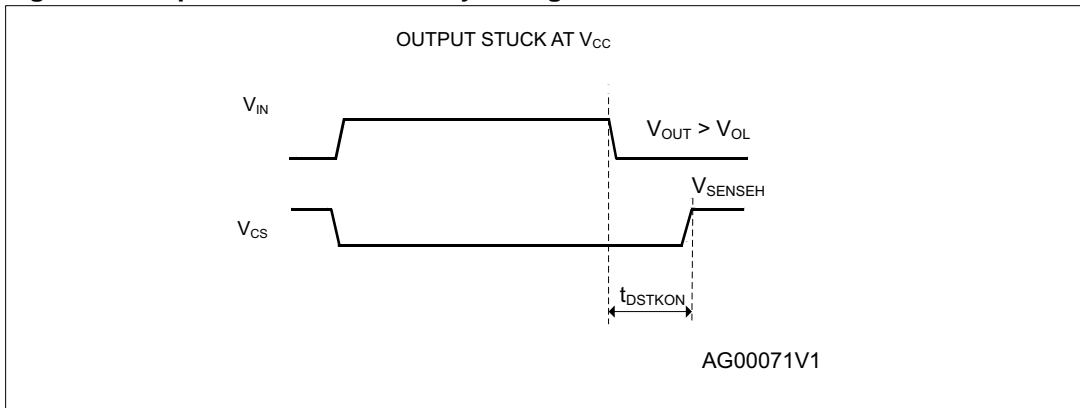

Figure 6. Switching characteristics

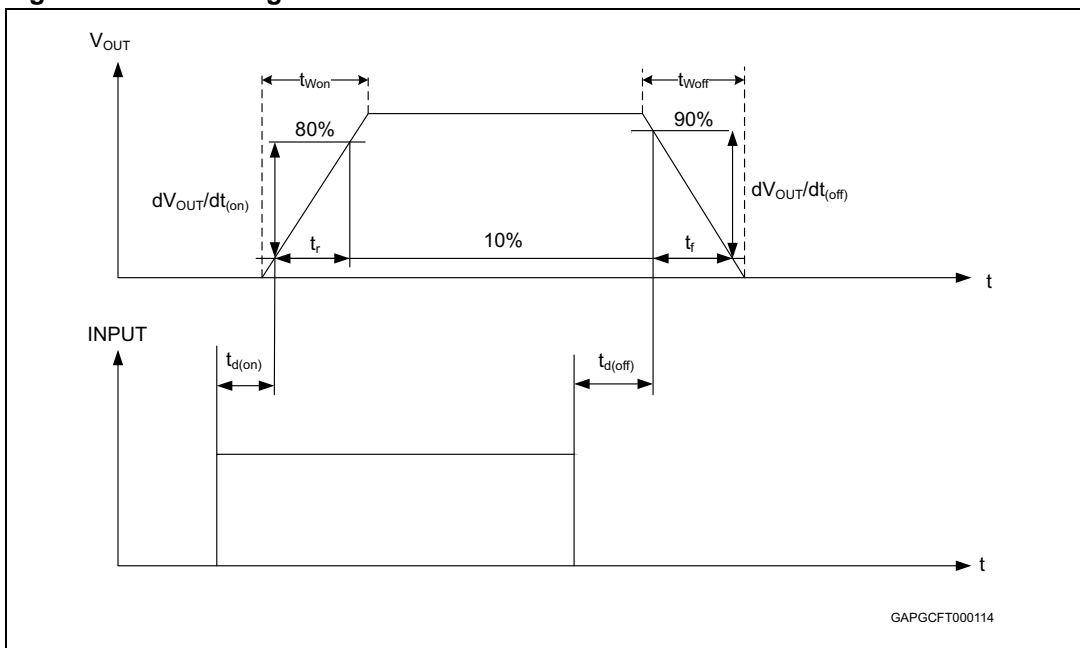

Figure 7. Delay response time between rising edge of output current and rising edge of current sense (CS enabled)

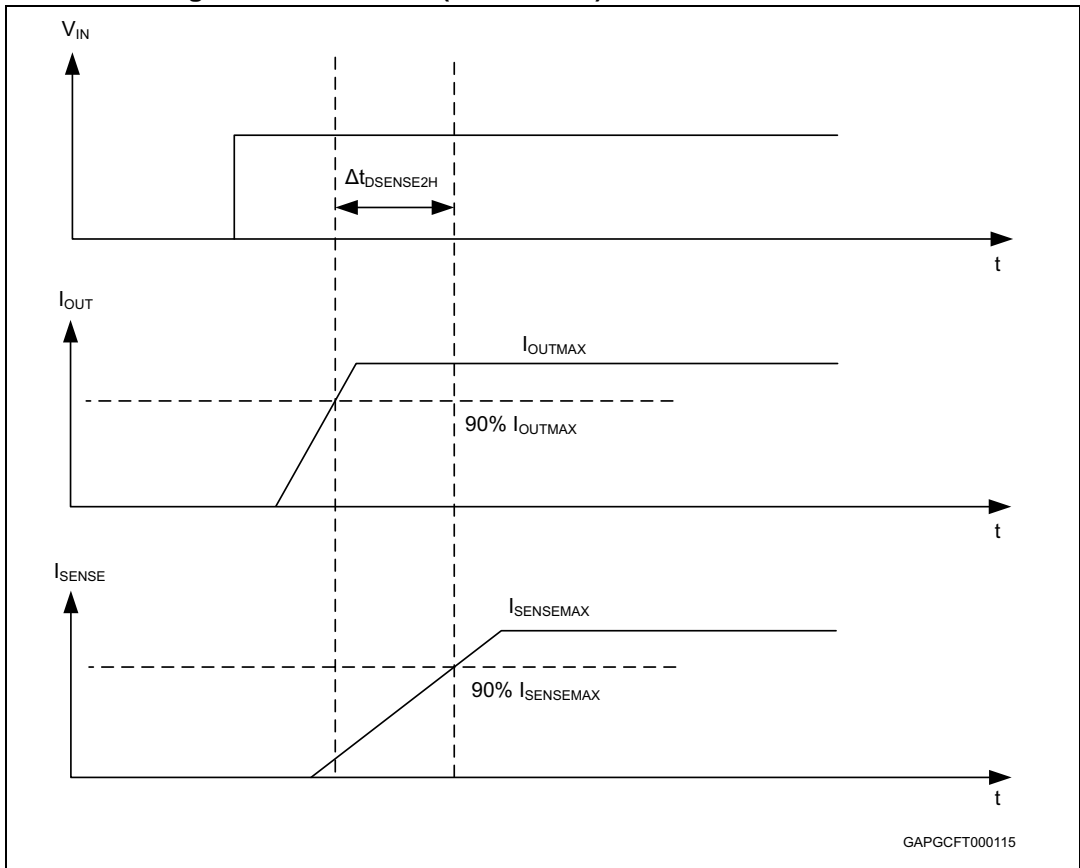

Figure 8. Output voltage drop limitation

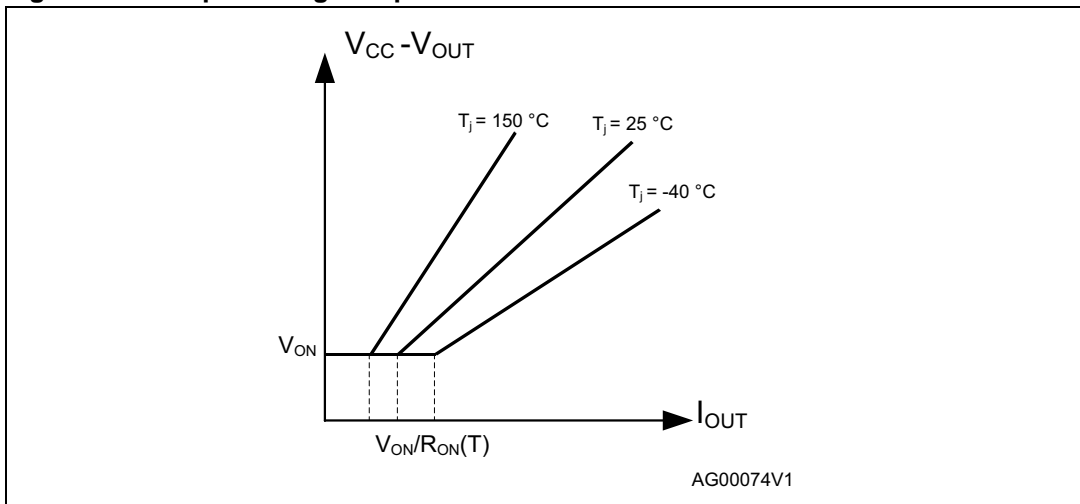

Figure 9. I_{OUT}/I_{SENSE} vs I_{OUT}

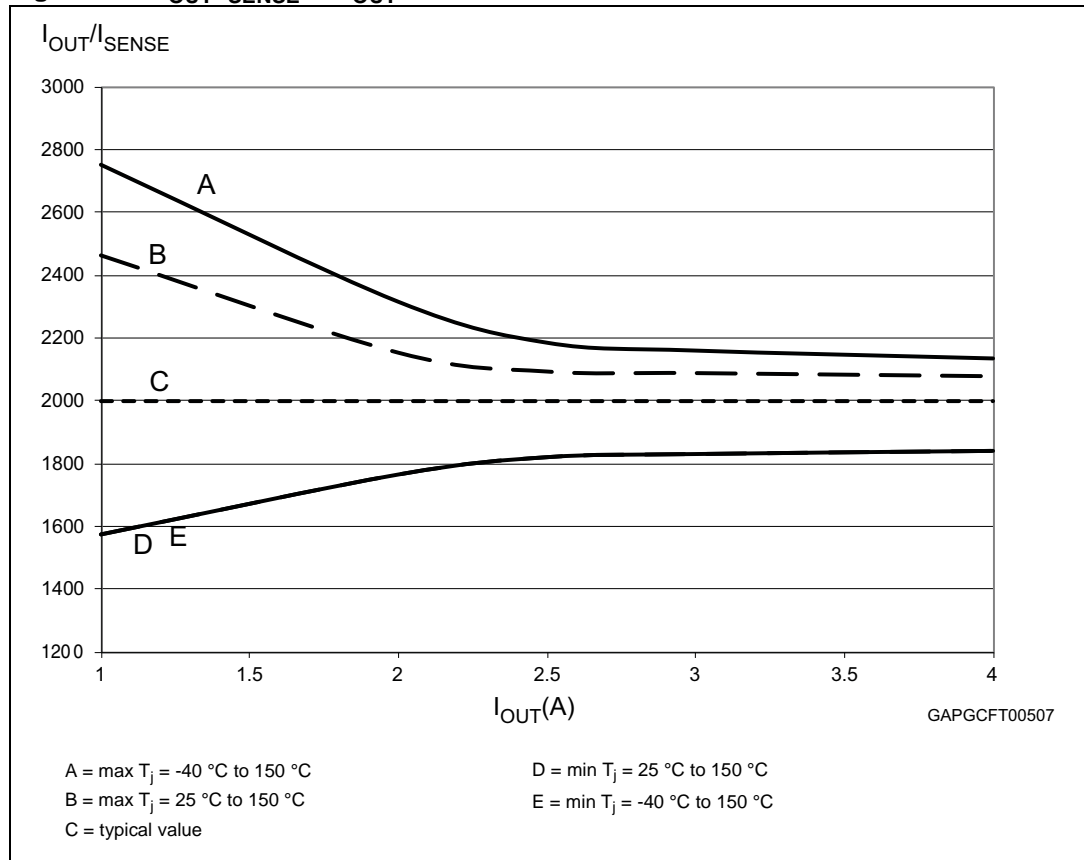
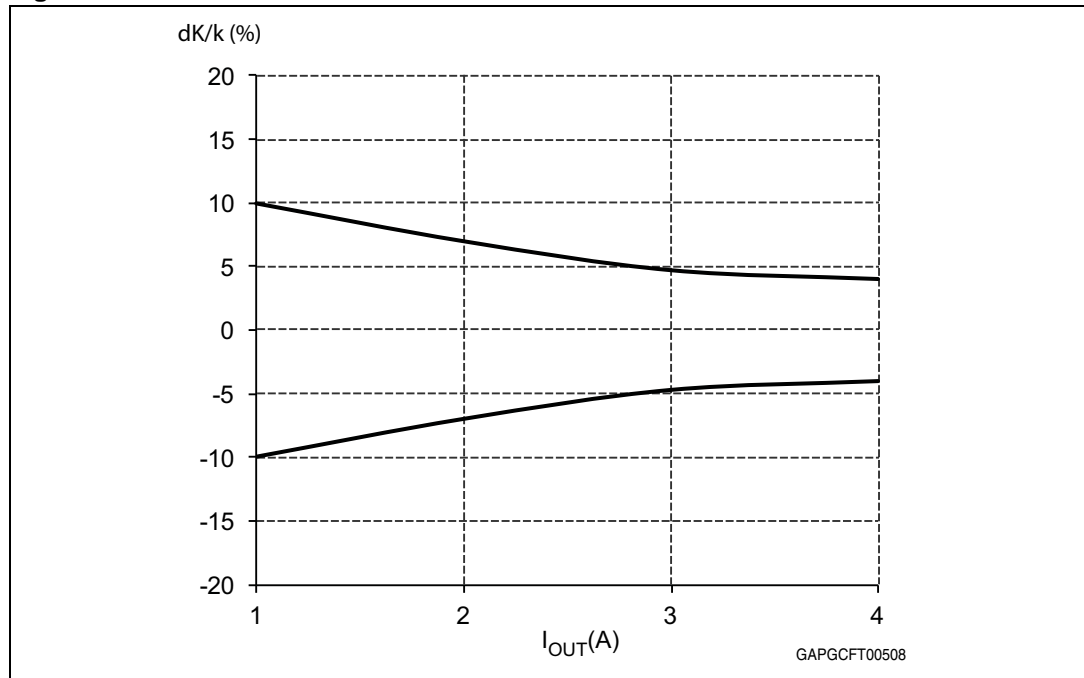

Figure 10. Maximum current sense ratio drift vs load current



Note: Parameter guaranteed by design; it is not tested.

Table 11. Truth table

Conditions	Input	Output	Sense ($V_{CSD} = 0\text{ V}$) ⁽¹⁾
Normal operation	L	L	0
	H	H	Nominal
Overtemperature	L	L	0
	H	L	V_{SENSEH}
Undervoltage	L	L	0
	H	L	0
Overload	H	X (no power limitation)	Nominal
	H	Cycling (power limitation)	V_{SENSEH}
Short circuit to GND (power limitation)	L	L	0
	H	L	V_{SENSEH}
Open-load off-state (with external pull-up)	L	H	V_{SENSEH}
Short circuit to V_{CC} (external pull-up disconnected)	L	H	V_{SENSEH}
	H	H	V_{SENSEH} < Nominal
Negative output voltage clamp	L	L	0

1. If the V_{CSD} is high, the SENSE output is at a high impedance, its potential depends on leakage currents and external circuit.

Table 12. Electrical transient requirements (part 1)

ISO 7637-2: 2004(E) Test pulse	Test levels ⁽¹⁾		Number of pulses or test times	Burst cycle/pulse repetition time		Delays and Impedance
	III	IV		Min.	Max.	
1	-75V	-100V	5000 pulses	0.5s	5s	2 ms, 10Ω
2a	+37V	+50V	5000 pulses	0.2s	5s	50μs, 2Ω
3a	-100V	-150V	1h	90ms	100ms	0.1μs, 50Ω
3b	+75V	+100V	1h	90ms	100ms	0.1μs, 50Ω
4	-6V	-7V	1 pulse			100ms, 0.01Ω
5b ⁽²⁾	+65V	+87V	1 pulse			400ms, 2Ω

1. The above test levels must be considered referred to $V_{CC} = 13.5\text{ V}$ except for pulse 5b.
2. Valid in case of external load dump clamp: 40 V maximum referred to ground.

Table 13. Electrical transient requirements (part 2)

ISO 7637-2: 2004E Test pulse	Test level results	
	III	VI
1	C	C
2a	C	C
3a	C	C
3b	C	C
4	C	C
5b ⁽¹⁾	C	C

1. Valid in case of external load dump clamp: 40V maximum referred to ground.

Table 14. Electrical transient requirements (part 3)

Class	Contents
C	All functions of the device performed as designed after exposure to disturbance.
E	One or more functions of the device did not perform as designed after exposure to disturbance and cannot be returned to proper operation without replacing the device.

2.4 Waveforms

Figure 11. Normal operation

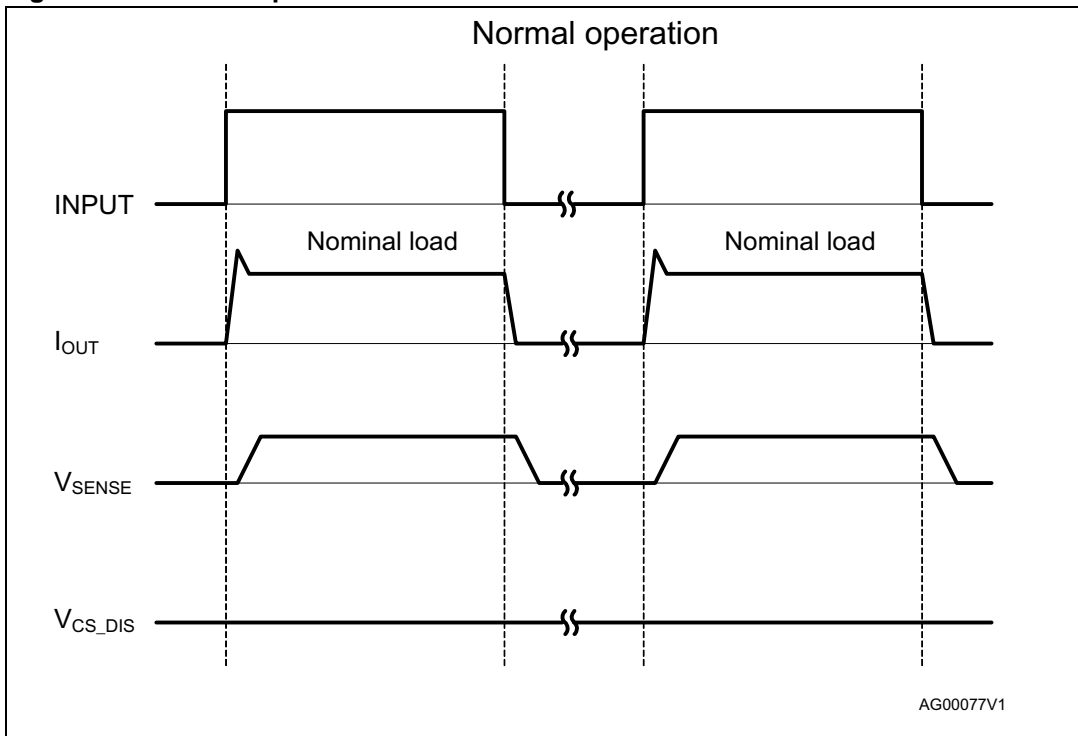

Figure 12. Overload or short to GND

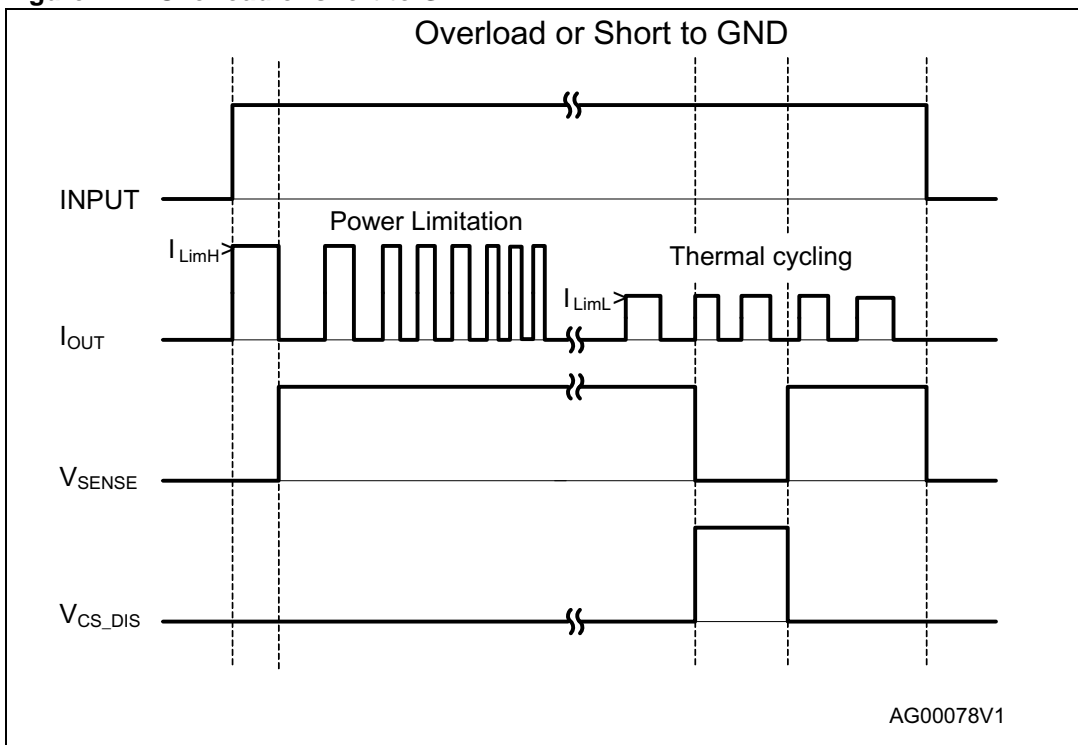
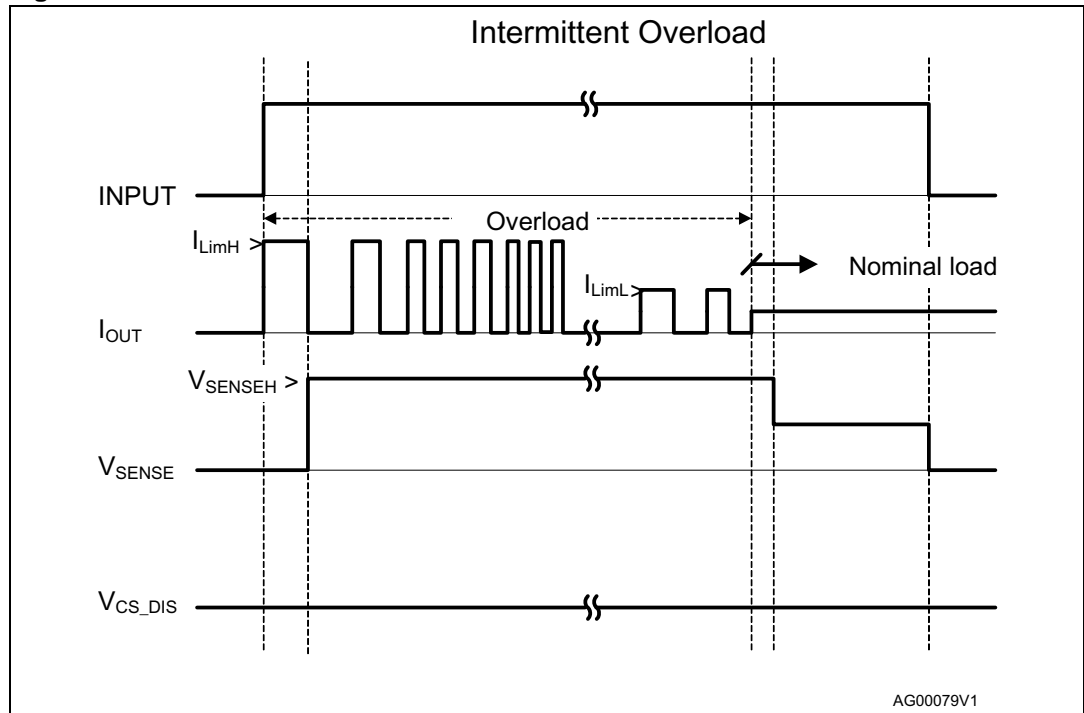
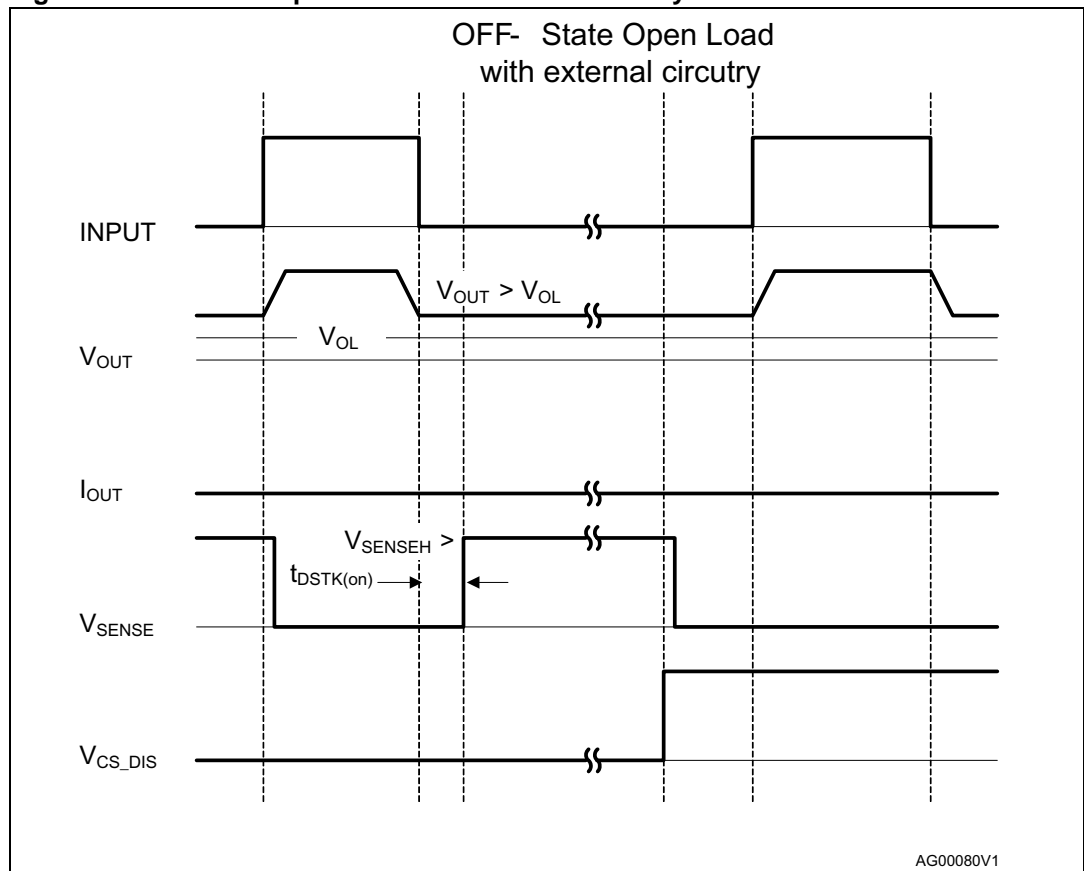

Figure 13. Intermittent overload



AG00079V1

Figure 14. Off-state open-load with external circuitry



AG00080V1

Figure 15. Short to V_{CC}

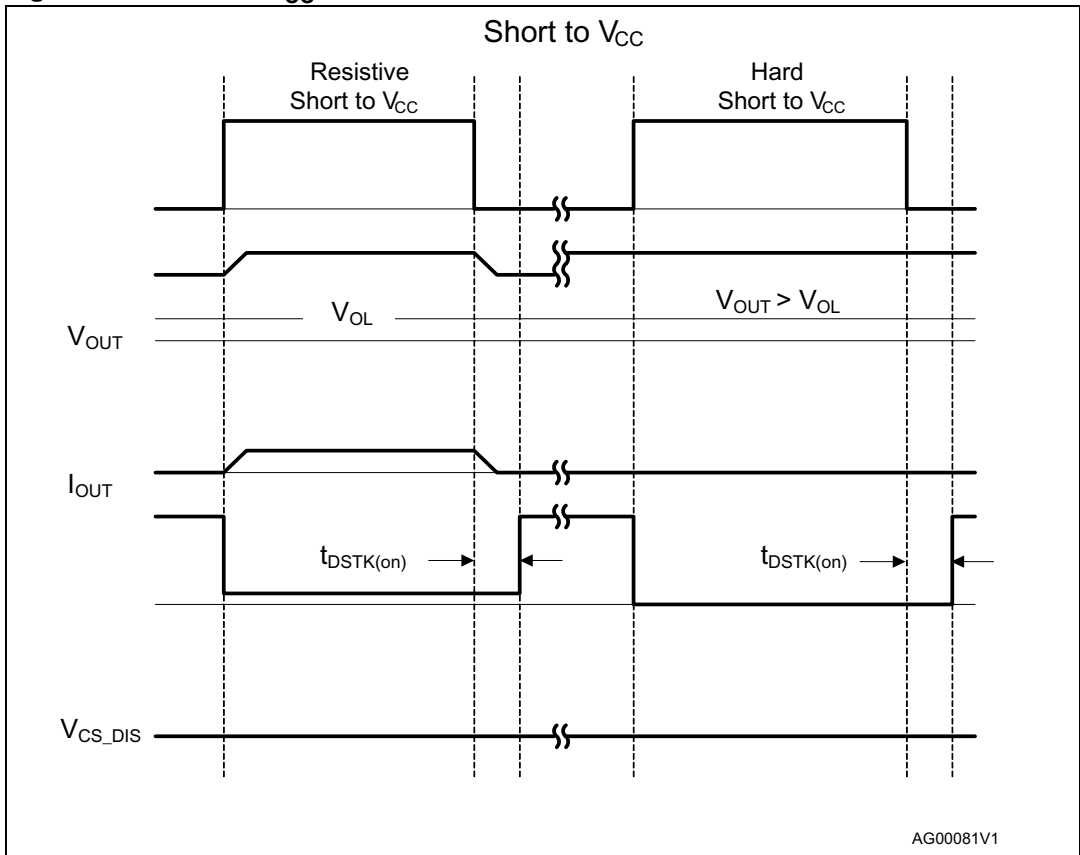
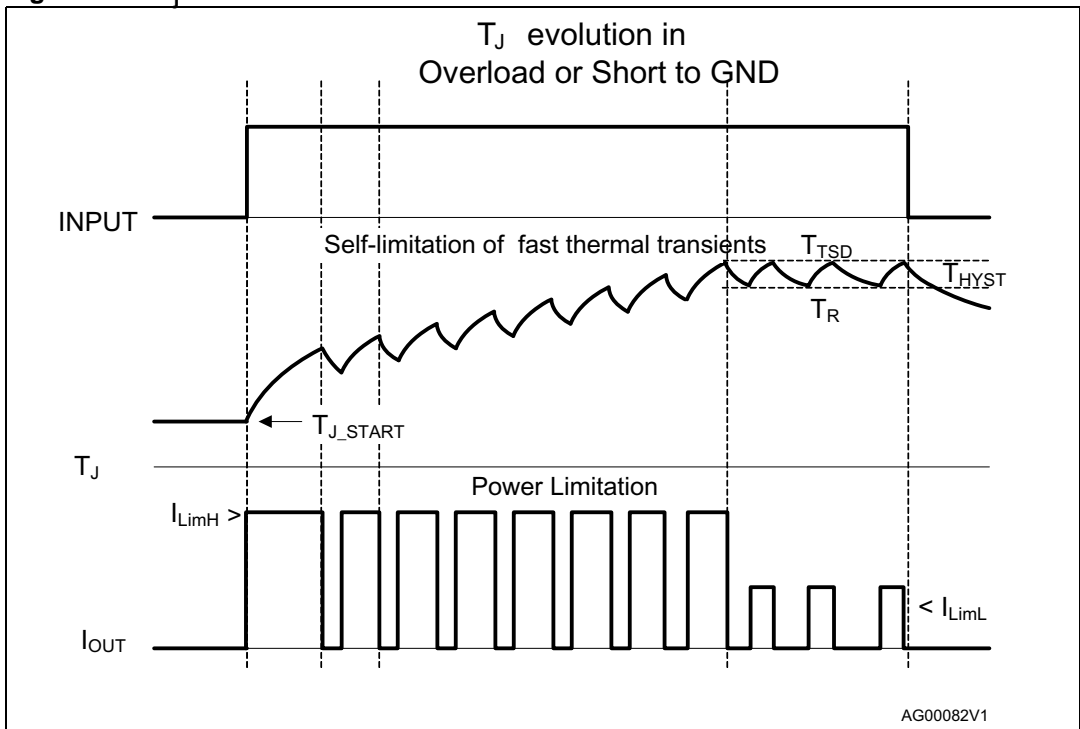

Figure 16. T_J evolution in over load or short to GND



2.5 Electrical characteristics curves

Figure 17. Off-state output current

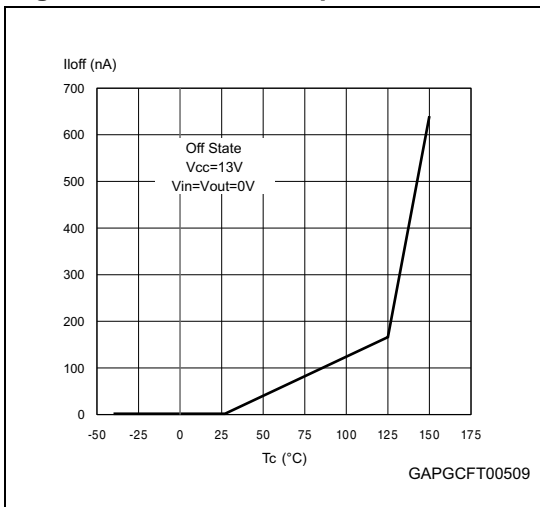

Figure 18. High level input current

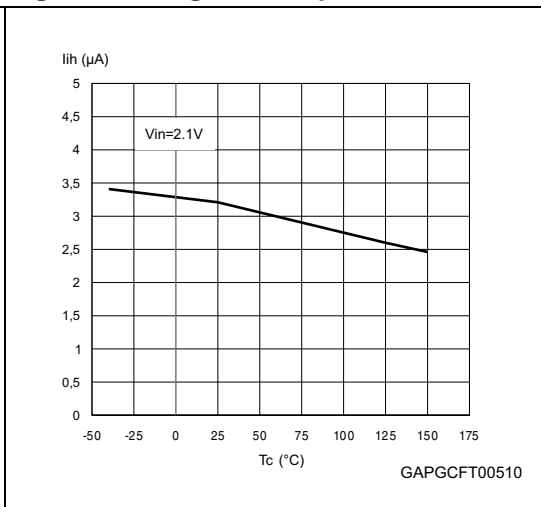

Figure 19. Input clamp level

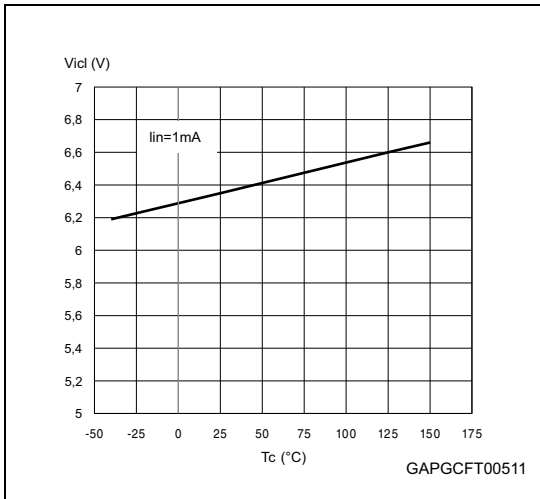

Figure 20. Input low level

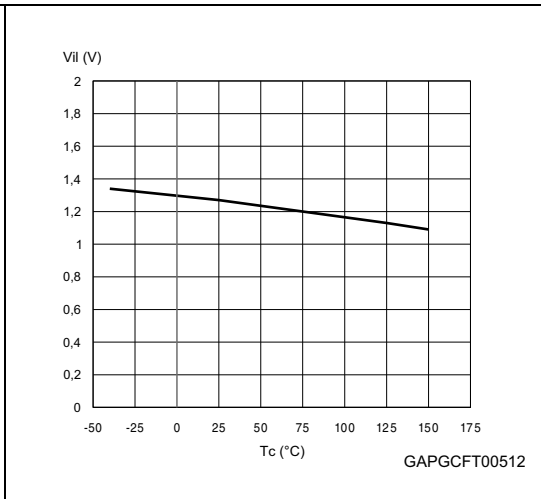

Figure 21. Input high level

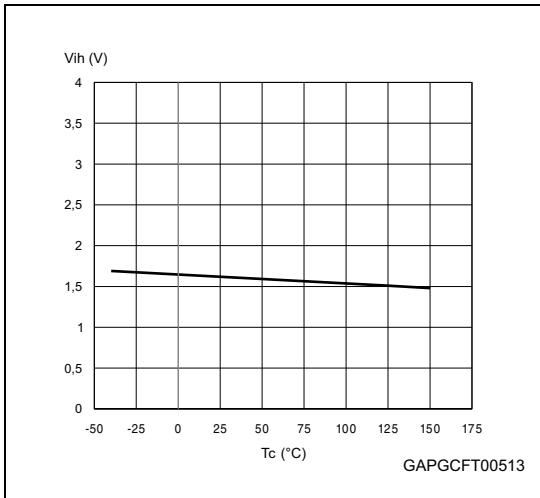

Figure 22. Input hysteresis voltage

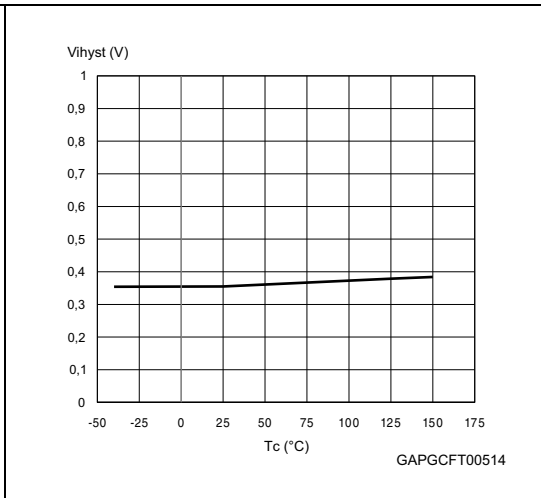

Figure 23. On-state resistance vs T_{case}

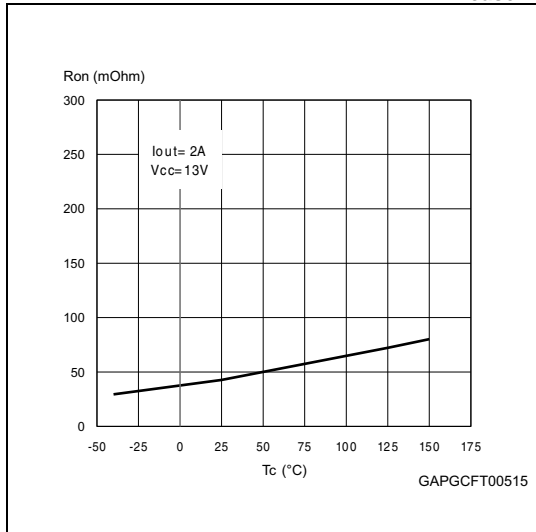

Figure 24. On-state resistance vs V_{CC}

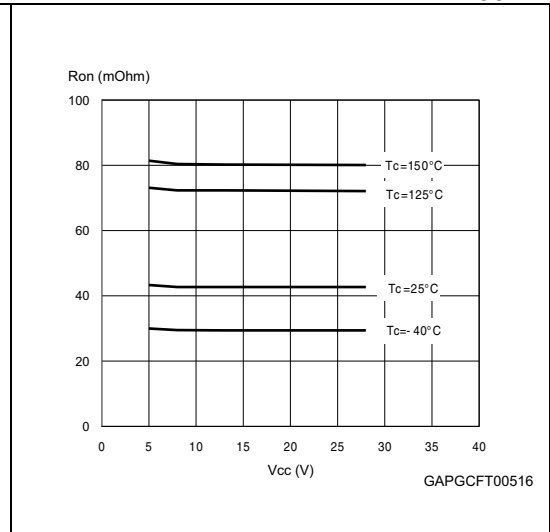

Figure 25. Undervoltage shutdown

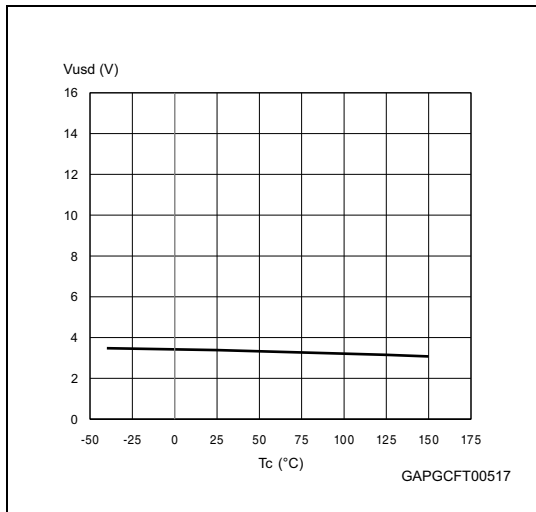

Figure 26. Turn-On voltage slope

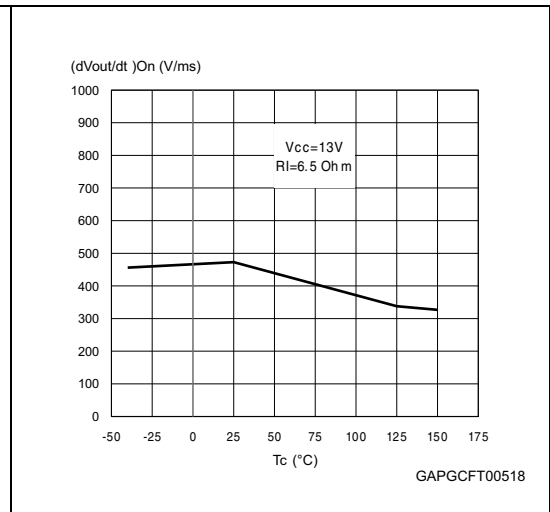

Figure 27. I_{LIMH} vs T_{case}

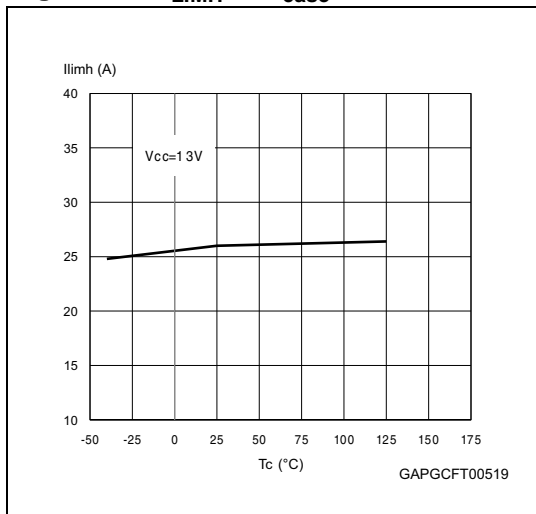

Figure 28. Turn-Off voltage slope

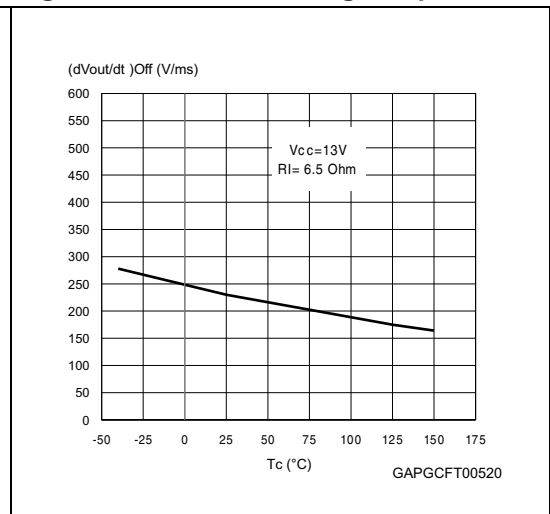

Figure 29. CS_DIS high level voltage

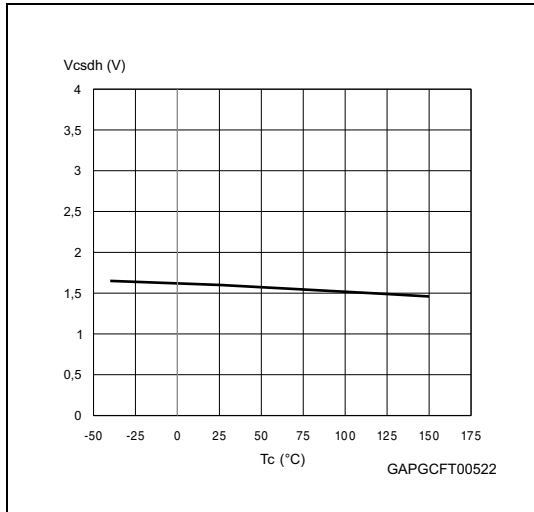

Figure 30. CS_DIS clamp voltage

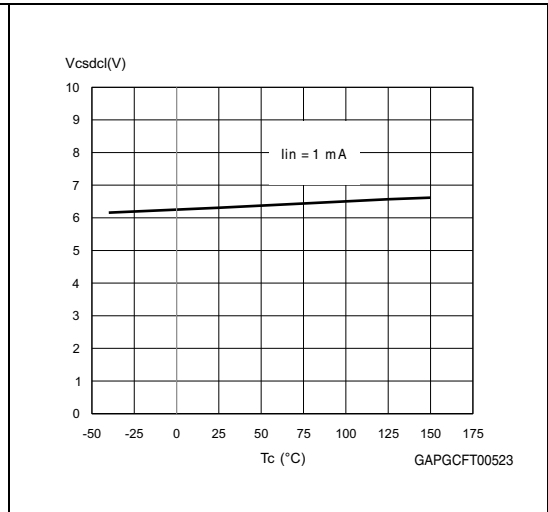
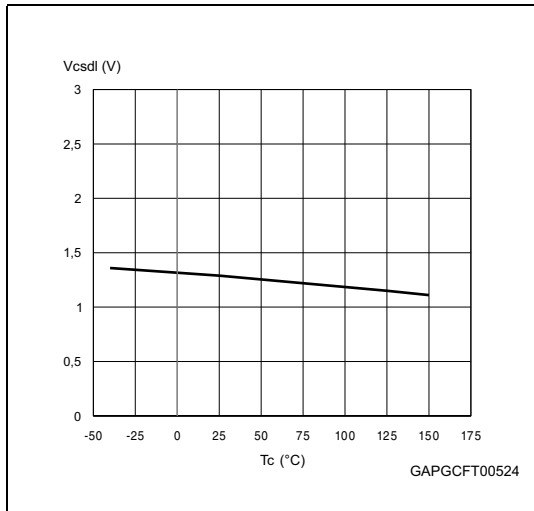
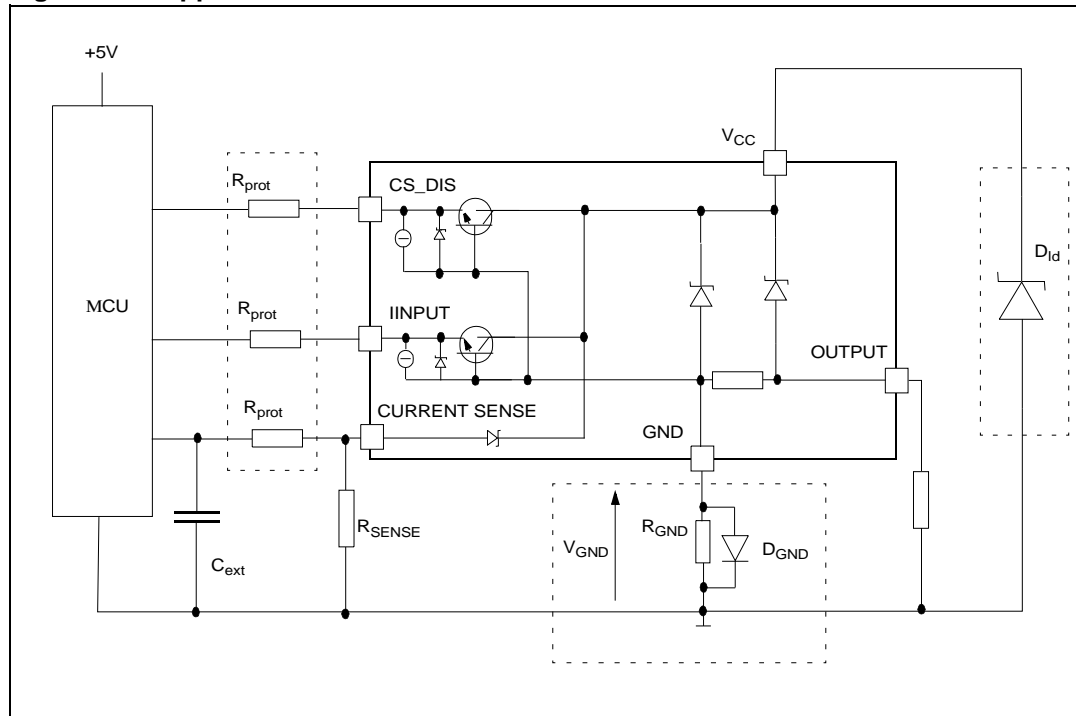

Figure 31. CS_DIS low level voltage



3 Application information

Figure 32. Application schematic



3.1 GND protection network against reverse battery

This section provides two solutions to implement a ground protection network against reverse battery.

3.1.1 Solution 1: resistor in the ground line (R_{GND} only)

This can be used with any type of load.

The following description shows how to select the R_{GND} resistor:

1. $R_{GND} \leq 600 \text{ mV} / (I_{S(on)max})$
2. $R_{GND} \geq (-V_{CC}) / (-I_{GND})$

where -I_{GND} is the DC reverse ground pin current and can be found in the absolute maximum rating section of the device datasheet.

Power dissipation in R_{GND} (when V_{CC} < 0 during reverse battery situations) is:

$$P_D = (-V_{CC})^2 / R_{GND}$$

This resistor can be shared amongst several different HSDs. Please note that the value of this resistor should be calculated with formula (1) where I_{S(on)max} becomes the sum of the maximum on-state currents of the different devices.

Please note that, if the microprocessor ground is not shared by the device ground, then the R_{GND} produces a shift (I_{S(on)max} * R_{GND}) in the input thresholds and in the status output

values. This shift varies depending on how many devices are ON in case of several high side drivers sharing the same R_{GND} .

If the calculated power dissipation requires the use of a large resistor, or several devices have to share the same resistor, then ST suggests to utilize [Section 3.1.2: Solution 2: diode \(\$D_{GND}\$ \) in the ground line](#).

3.1.2 Solution 2: diode (D_{GND}) in the ground line

Note that a resistor ($R_{GND} = 1 \text{ k}\Omega$) should be inserted in parallel to D_{GND} if the device drives an inductive load.

This small signal diode can be safely shared amongst several different HSDs. Also in this case, the presence of the ground network will produce a shift ($\approx 600 \text{ mV}$) in the input threshold and in the status output values if the microprocessor ground is not common to the device ground. This shift will not vary if more than one HSD shares the same diode/resistor network.

3.2 Load dump protection

D_{ld} is necessary (Voltage Transient Suppressor) if the load dump peak voltage exceeds the V_{CC} maximum DC rating. The same applies if the device is subject to transients on the V_{CC} line which are greater than the ones shown in the ISO 7637-2: 2004(E) table.

3.3 MCU I/O protection

If a ground protection network is used and negative transients are present on the V_{CC} line, the control pins are pulled negative. ST suggests to insert a resistor (R_{prot}) in line to prevent the microcontroller I/O pins from latching up.

The value of these resistors is a compromise between the leakage current of microcontroller and the current required by the HSD I/Os (Input levels compatibility) with the latch-up limit of microcontroller I/Os:

$$-V_{CCpeak}/I_{latchup} \leq R_{prot} \leq (V_{OH\mu C} - V_{IH} - V_{GND}) / I_{IHmax}$$

Calculation example:

For $V_{CCpeak} = -100 \text{ V}$ and $I_{latchup} \geq 20 \text{ mA}$; $V_{OH\mu C} \geq 4.5 \text{ V}$

$$5 \text{ k}\Omega \leq R_{prot} \leq 180 \text{ k}\Omega$$

Recommended values: $R_{prot} = 10 \text{ k}\Omega$, $C_{EXT} = 10 \text{ nF}$.

3.4 Current sense and diagnostic

The current sense pin performs a double function (see [Figure 33: Current sense and diagnostic](#)):

- **Current mirror of the load current in normal operation**, delivering a current proportional to the load current according to a known ratio K_X .
The current I_{SENSE} can be easily converted to a voltage V_{SENSE} by means of an external resistor R_{SENSE} . Linearity between I_{OUT} and V_{SENSE} is ensured up to 5V minimum (see parameter V_{SENSE} in [Table 9: Current sense \(8 V < VCC < 18 V\)](#)). The

current sense accuracy depends on the output current (refer to current sense electrical characteristics [Table 9: Current sense \(8 V < V_{CC} < 18 V\)](#)).

- **Diagnostic flag in fault conditions**, delivering a fixed voltage V_{SENSEH} up to a maximum current I_{SENSEH} in case of the following fault conditions (refer to [Table 11: Truth table](#)):
 - Power limitation activation
 - Overtemperature
 - Short to V_{CC} in off-state
 - Open-load in off-state with additional external components.

A logic level high the CS_DIS pin simultaneously sets all the current sense pins of the device in a high impedance state, thus disabling the current monitoring and diagnostic detection. This feature allows multiplexing of the microcontroller analog inputs by sharing the sense resistance and ADC line among different devices.

Figure 33. Current sense and diagnostic

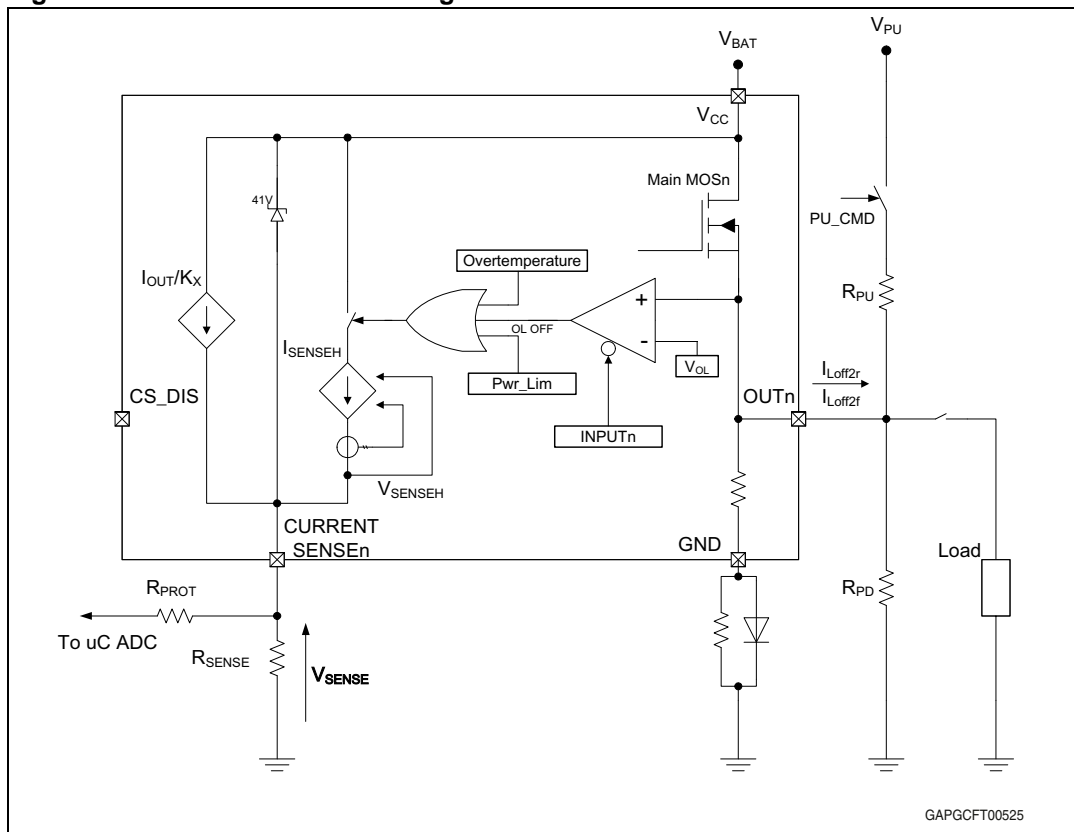

3.4.1 Short to V_{CC} and off-state open-load detection

Short to V_{CC}

A short circuit between V_{CC} and output is indicated by the relevant current sense pin set to V_{SENSEH} during the device off-state. Little or no current is delivered by the current sense during the on-state depending on the nature of the short circuit.

Off-state open-load with external circuitry

Detection of an open-load in off mode requires an external pull-up resistor (R_{PU}) connecting the output to a positive supply voltage (V_{PU}).

It is preferable that V_{PU} is switched off during the module standby mode to avoid an increase in overall standby current consumption in normal conditions, that is, when the load is connected.

An external pull-down resistor (R_{PD}) connected between output and GND is mandatory to avoid misdetection in case of floating outputs in off-state (see [Figure 33: Current sense and diagnostic](#)).

R_{PD} must be selected in order to ensure $V_{OUT} < V_{OLmin}$ unless pulled up by the external circuitry:

$$V_{OUT}|_{Pull-up_OFF} = R_{PD} \cdot I_{L(off)2f} < V_{OLmin} = 2V$$

$R_{PD} \leq 22 \text{ K}\Omega$ is recommended.

For proper open-load detection in off-state, the external pull-up resistor must be selected according to the following formula:

$$V_{OUT}|_{Pull-up_ON} = \frac{R_{PD} \cdot V_{PU} - R_{PU} \cdot R_{PD} \cdot I_{L(off)2r}}{R_{PU} + R_{PD}} > V_{OLmax} = 4V$$

For the values of V_{OLmin} , V_{OLmax} , $I_{L(off)2r}$ and $I_{L(off)2f}$ see [Table 10: Open-load detection \(8 V < VCC < 18 V\)](#).

3.5 Maximum demagnetization energy ($V_{CC} = 13.5V$)

Figure 34. Maximum turn-Off current versus inductance

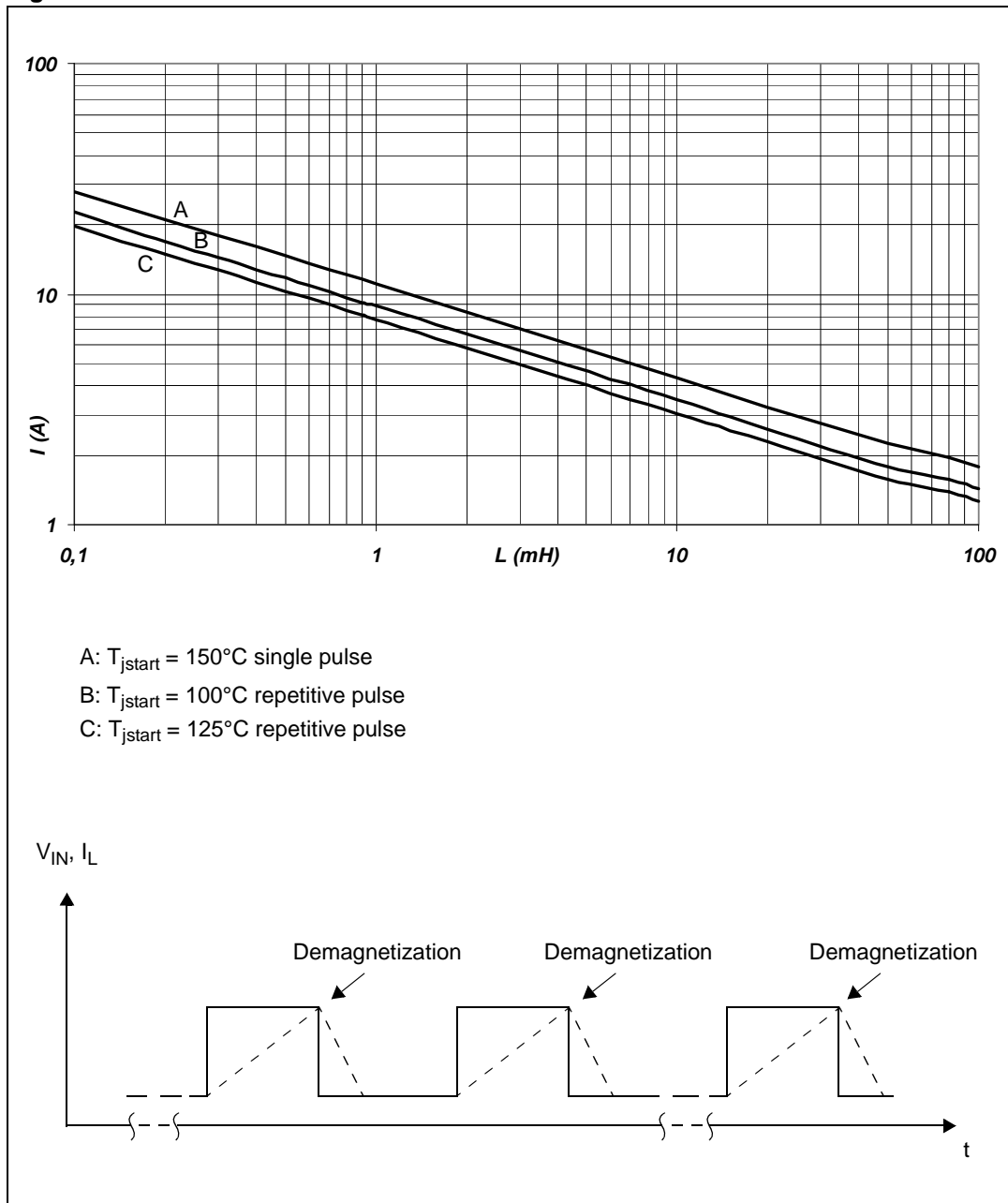

Note: Values are generated with $R_L = 0 \Omega$. In case of repetitive pulses, T_{jstart} (at the beginning of each demagnetization) of every pulse must not exceed the temperature specified above for curves A and B.

4 Package and PCB thermal data

4.1 SO-16L thermal data

Figure 35. SO-16L PC board

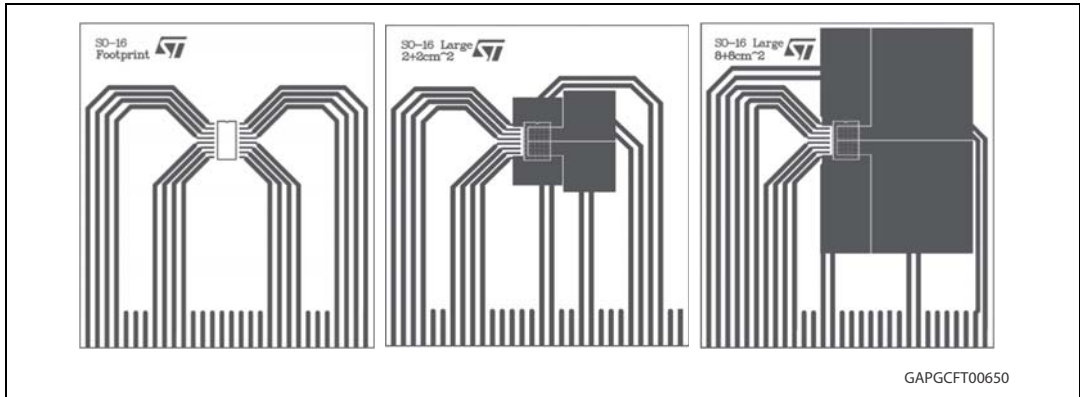

Note: Layout condition of R_{th} and Z_{th} measurements (PCB: Double layer, Thermal Vias, FR4 area = 77 mm x 86 mm, PCB thickness = 1.6 mm, Cu thickness = 70 μ m (front and back side), Copper areas: from minimum pad lay-out to 8 cm²).

Figure 36. $R_{thj-amb}$ vs PCB copper area in open box free air condition

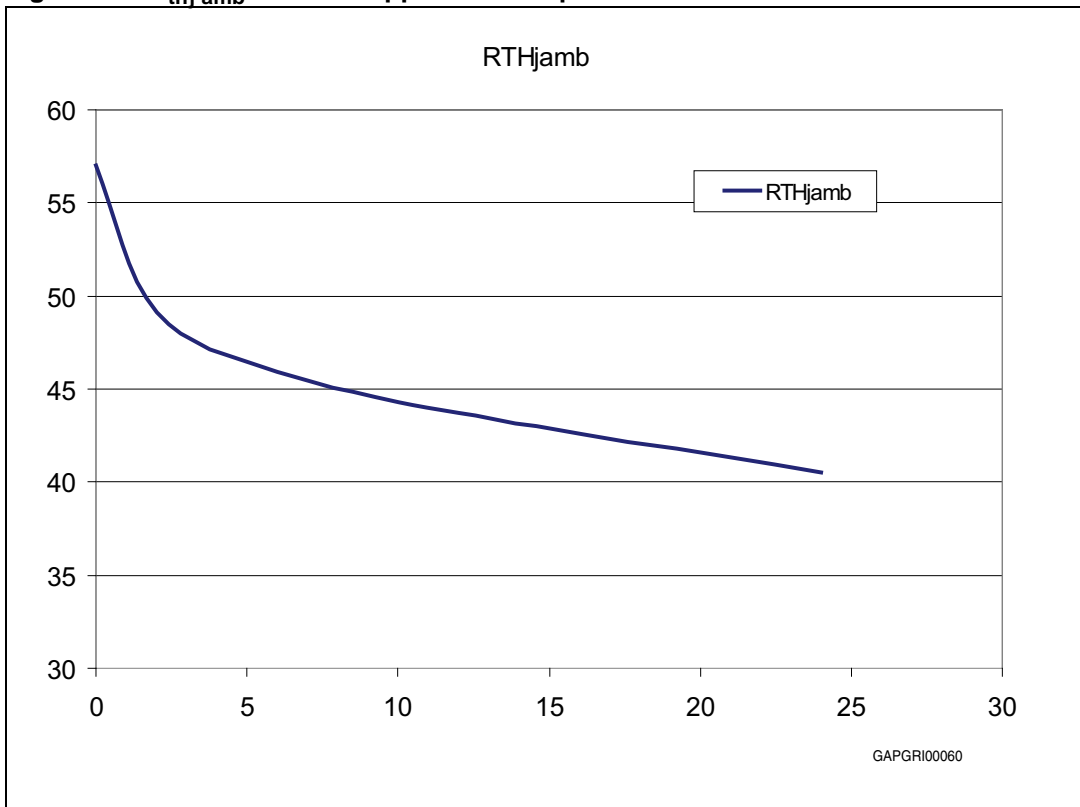
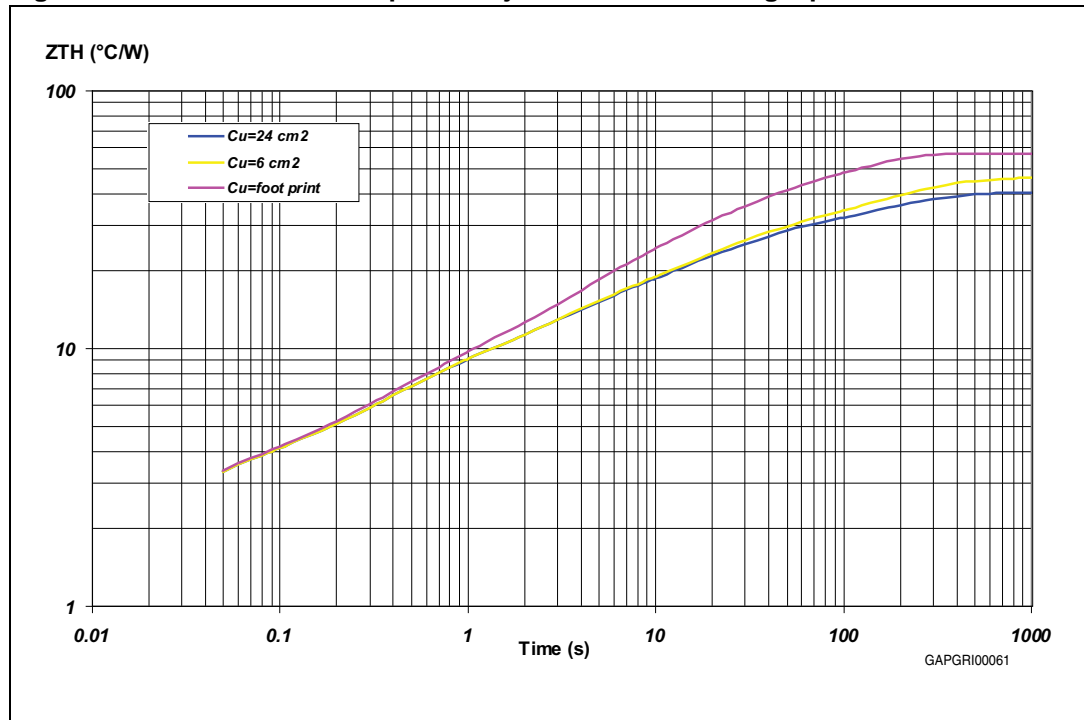

Figure 37. SO-16L thermal impedance junction ambient single pulse



Equation 1: pulse calculation formula

$$Z_{TH\delta} = R_{TH} \cdot \delta + Z_{THtp}(1 - \delta)$$

where $\delta = t_p/T$

Figure 38. Thermal fitting model of a single channel HSD in SO-16L (a)

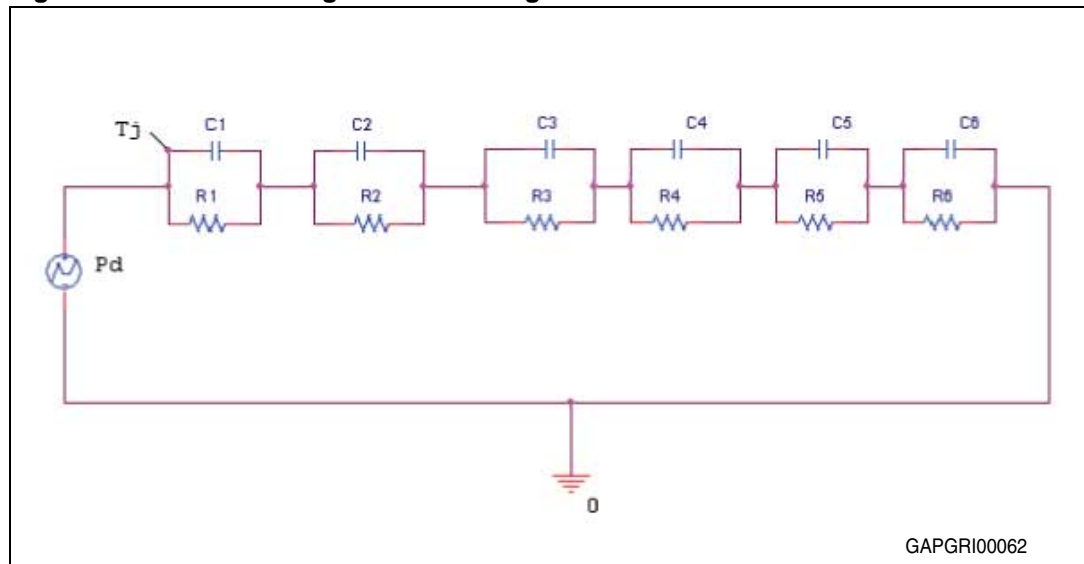

- a. The fitting model is a simplified thermal tool and is valid for transient evolutions where the embedded protections (power limitation or thermal cycling during thermal shutdown) are not triggered.

Table 15. Thermal parameter

Area/island (cm ²)	Footprint	2	8
R1 (°C/W)	0.7		
R2 (°C/W)	2.3		
R3 (°C/W)	4		
R4 (°C/W)	8	6	6
R5 (°C/W)	14	13	13
R6 (°C/W)	28	20	14.5
C1 (W.s/°C)	0.001		
C2 (W.s/°C)	0.01		
C3 (W.s/°C)	0.1		
C4 (W.s/°C)	0.5		
C5 (W.s/°C)	1	1.5	1.5
C6 (W.s/°C)	3	9	12

5 Package information

5.1 ECOPACK® packages

In order to meet environmental requirements, ST offers these devices in different grades of ECOPACK® packages, depending on their level of environmental compliance. ECOPACK® specifications, grade definitions and product status are available at: www.st.com.

ECOPACK® is an ST trademark.

5.2 Package mechanical data

Figure 39. SO-16L package dimensions

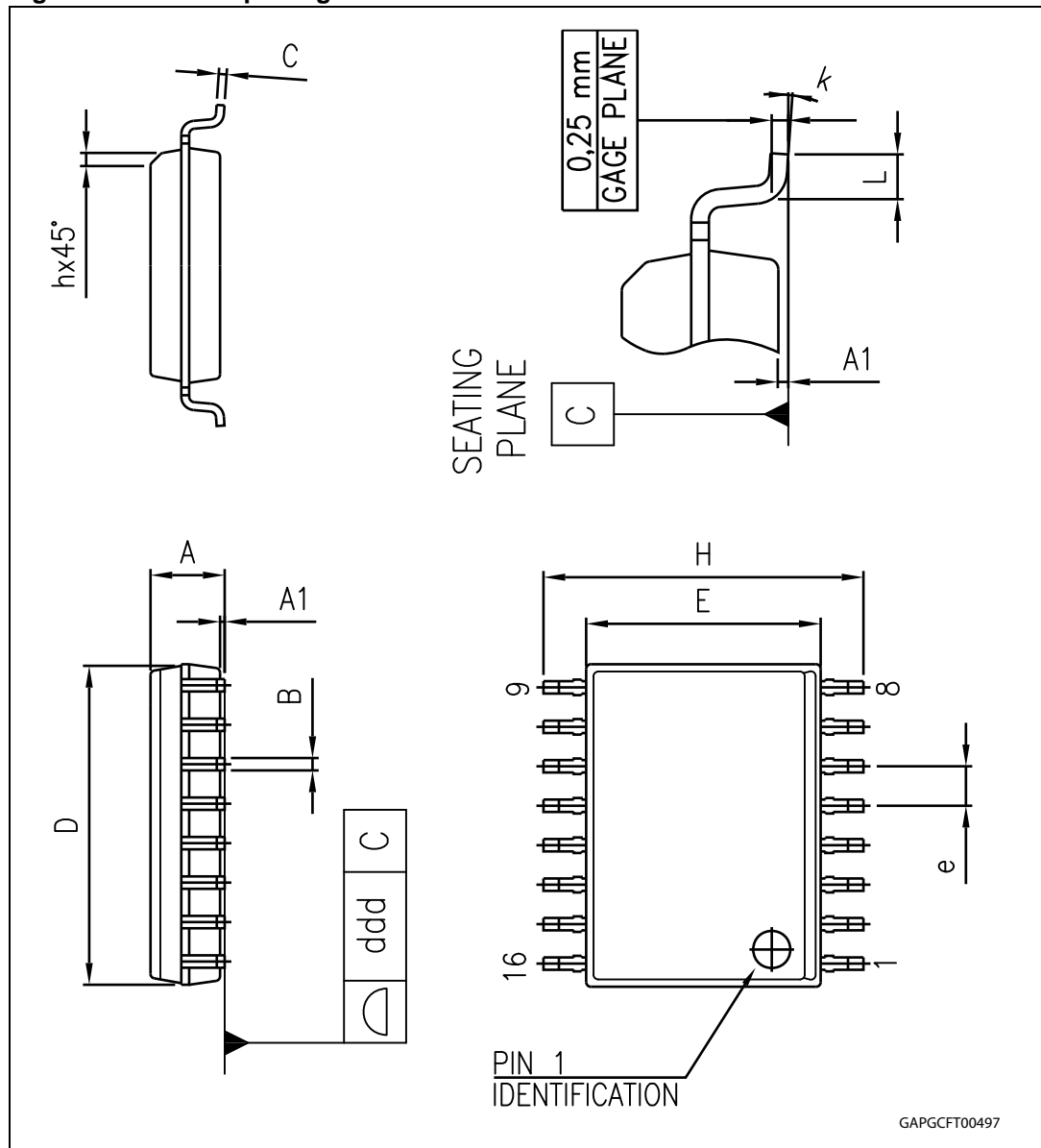

Table 16. SO-16L mechanical data

Symbol	Millimeters		
	Min	Typ	Max
A	2.35		2.65
A1	0.10		0.30
B	0.33		0.51
C	0.23		0.32
D	10.10		10.50
E	7.40		7.60
e		1.27	
H	10.00		10.65
h	0.25		0.75
L	0.40		1.27
k	0°		8°
ddd			0.10

5.3 Packing information

Figure 40. SO-16L tube shipment (no suffix)

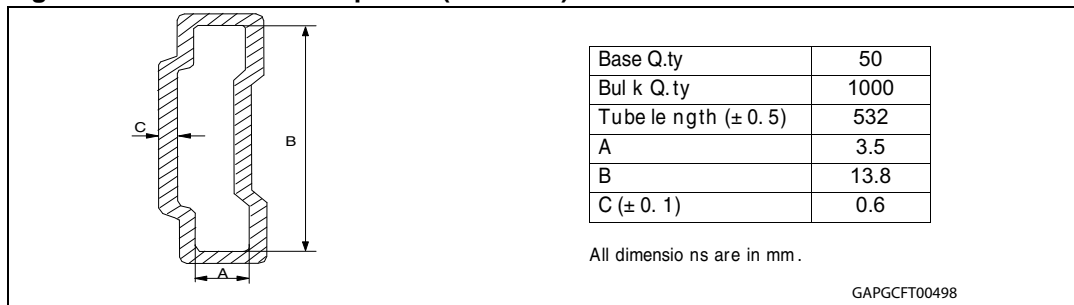
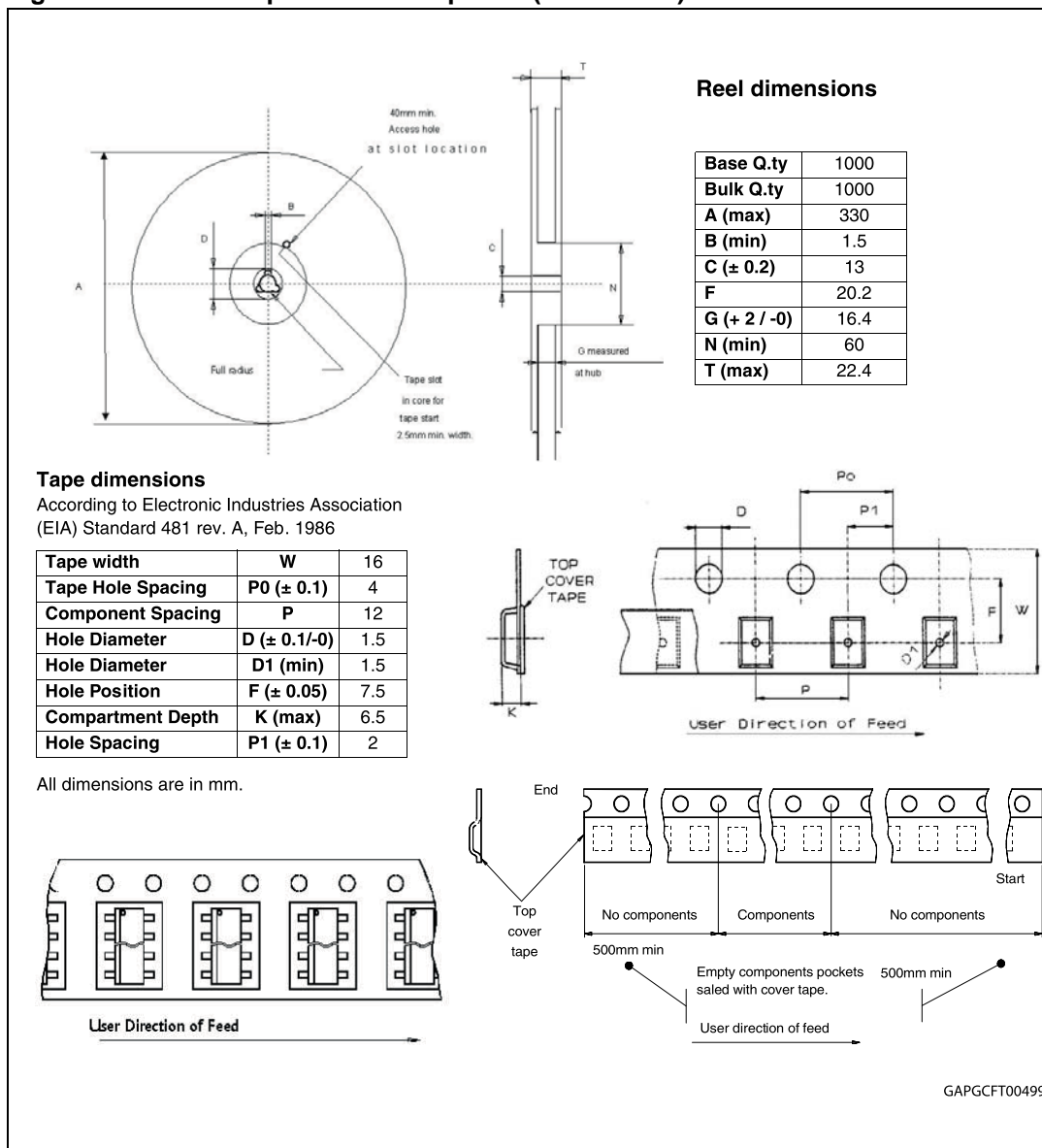

Figure 41. SO-16L tape and reel shipment (suffix "TR")



6 Order codes

Table 17. Device summary

Package	Order codes	
	Tube	Tape and reel
SO-16L	VN5E050ASO-E	VN5E050ASOTR-E

7 Revision history

Table 18. Document revision history

Date	Revision	Changes
14-Dec-2011	1	Initial release
16-Mar-2012	2	Added Section 4: Package and PCB thermal data and update Table 5 .
25-June-2012	3	Update Table 4 .
18-Sep-2012	4	Update Table 4 .
18-Sep-2013	5	Updated disclaimer.

Please Read Carefully:

Information in this document is provided solely in connection with ST products. STMicroelectronics NV and its subsidiaries ("ST") reserve the right to make changes, corrections, modifications or improvements, to this document, and the products and services described herein at any time, without notice.

All ST products are sold pursuant to ST's terms and conditions of sale.

Purchasers are solely responsible for the choice, selection and use of the ST products and services described herein, and ST assumes no liability whatsoever relating to the choice, selection or use of the ST products and services described herein.

No license, express or implied, by estoppel or otherwise, to any intellectual property rights is granted under this document. If any part of this document refers to any third party products or services it shall not be deemed a license grant by ST for the use of such third party products or services, or any intellectual property contained therein or considered as a warranty covering the use in any manner whatsoever of such third party products or services or any intellectual property contained therein.

UNLESS OTHERWISE SET FORTH IN ST'S TERMS AND CONDITIONS OF SALE ST DISCLAIMS ANY EXPRESS OR IMPLIED WARRANTY WITH RESPECT TO THE USE AND/OR SALE OF ST PRODUCTS INCLUDING WITHOUT LIMITATION IMPLIED WARRANTIES OF MERCHANTABILITY, FITNESS FOR A PARTICULAR PURPOSE (AND THEIR EQUIVALENTS UNDER THE LAWS OF ANY JURISDICTION), OR INFRINGEMENT OF ANY PATENT, COPYRIGHT OR OTHER INTELLECTUAL PROPERTY RIGHT.

ST PRODUCTS ARE NOT DESIGNED OR AUTHORIZED FOR USE IN: (A) SAFETY CRITICAL APPLICATIONS SUCH AS LIFE SUPPORTING, ACTIVE IMPLANTED DEVICES OR SYSTEMS WITH PRODUCT FUNCTIONAL SAFETY REQUIREMENTS; (B) AERONAUTIC APPLICATIONS; (C) AUTOMOTIVE APPLICATIONS OR ENVIRONMENTS, AND/OR (D) AEROSPACE APPLICATIONS OR ENVIRONMENTS. WHERE ST PRODUCTS ARE NOT DESIGNED FOR SUCH USE, THE PURCHASER SHALL USE PRODUCTS AT PURCHASER'S SOLE RISK, EVEN IF ST HAS BEEN INFORMED IN WRITING OF SUCH USAGE, UNLESS A PRODUCT IS EXPRESSLY DESIGNATED BY ST AS BEING INTENDED FOR "AUTOMOTIVE, AUTOMOTIVE SAFETY OR MEDICAL" INDUSTRY DOMAINS ACCORDING TO ST PRODUCT DESIGN SPECIFICATIONS. PRODUCTS FORMALLY ESCC, QML OR JAN QUALIFIED ARE DEEMED SUITABLE FOR USE IN AEROSPACE BY THE CORRESPONDING GOVERNMENTAL AGENCY.

Resale of ST products with provisions different from the statements and/or technical features set forth in this document shall immediately void any warranty granted by ST for the ST product or service described herein and shall not create or extend in any manner whatsoever, any liability of ST.

ST and the ST logo are trademarks or registered trademarks of ST in various countries.

Information in this document supersedes and replaces all information previously supplied.

The ST logo is a registered trademark of STMicroelectronics. All other names are the property of their respective owners.

© 2013 STMicroelectronics - All rights reserved

STMicroelectronics group of companies

Australia - Belgium - Brazil - Canada - China - Czech Republic - Finland - France - Germany - Hong Kong - India - Israel - Italy - Japan - Malaysia - Malta - Morocco - Philippines - Singapore - Spain - Sweden - Switzerland - United Kingdom - United States of America

www.st.com