

APPLICATIONS

Where transient overvoltage protection in sensitive equipment is required, such as:

- Universal Serial Bus ports
- RS-423 interfaces
- RS-485 interfaces
- ISDN equipment
- T1/E1 line cards
- HDSL / ASDL interfaces

FEATURES

- Full diode bridge with integrated clamping protection
- Breakdown voltage : $V_{BR} = 6V$ min.
- Peak pulse power dissipation : $P_{PP} = 500W$ (8/20 μ s)
- Very low capacitance, compatible with high debit data or signal rates.

DESCRIPTION

In order to prevent fast transients from leading to severe damages in a high speed data system, a specific protection has been developed by STMicroelectronics.

The **USB6Bx** protects the two input lines against overvoltage. Besides, this device also keeps the power rails in a safe limit thanks to the integrated Transil diode.

BENEFITS

- Provides protection for each line and between the supply voltage and GND : 25A , 8/20 μ s.
- High ESD protection level : up to level 3 per MIL STD 883C-Method 3015-6
- Separated inputs and outputs (so-called 4-point structure) to improve ESD susceptibility.
- Comprehensive package pin-out for immediate implementation.

COMPLIES WITH THE FOLLOWING STANDARDS:

MIL STD 883C - Method 3015-6

class 3 $C = 100$ pF $R = 1500$ Ω
3 positive strikes and 3 negative strikes ($F = 1$ Hz)

IEC-1000-4-2 level 4

15 kV (air discharge)
8 kV (contact discharge)

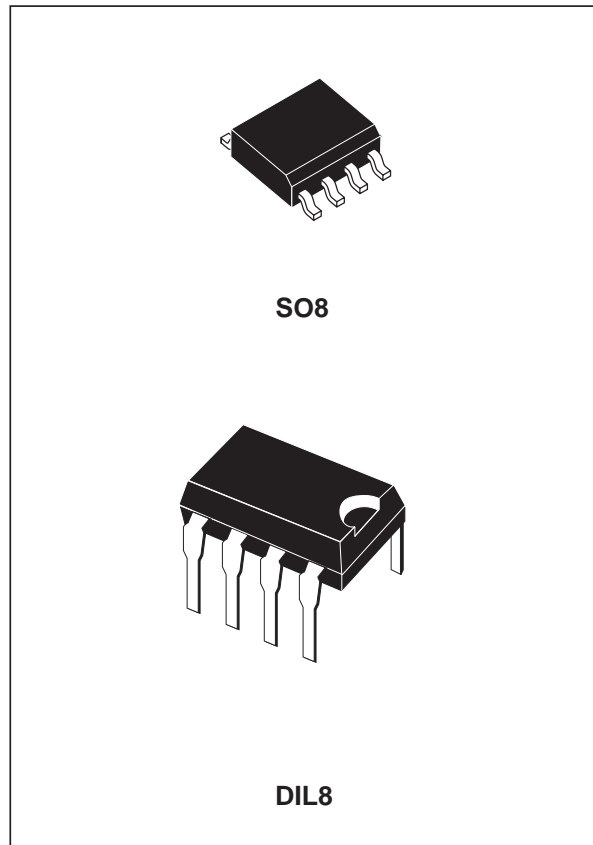

FUNCTIONAL DIAGRAM

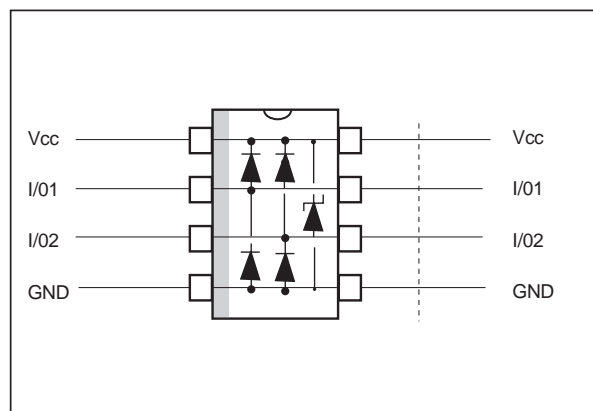

TM: ASD and TRANSIL are trademarks of ST Microelectronics.

USB6Bx

TECHNICAL INFORMATION

SURGE PROTECTION

The USB6Bx is particularly optimized to perform surge protection based on the rail to rail topology.

The clamping voltage V_{CL} can be estimated as follow:

$$\begin{aligned} V_{CL+} &= V_{CC} + V_F && \text{for positive surges} \\ V_{CL-} &= -V_F && \text{for negative surges} \end{aligned}$$

with: $V_F = V_t + r_d \cdot I_p$

(V_F forward drop voltage) / (V_t forward drop threshold voltage)

Note: the estimations do not take into account phenomena due to parasitic inductances.

Fig. A1 :

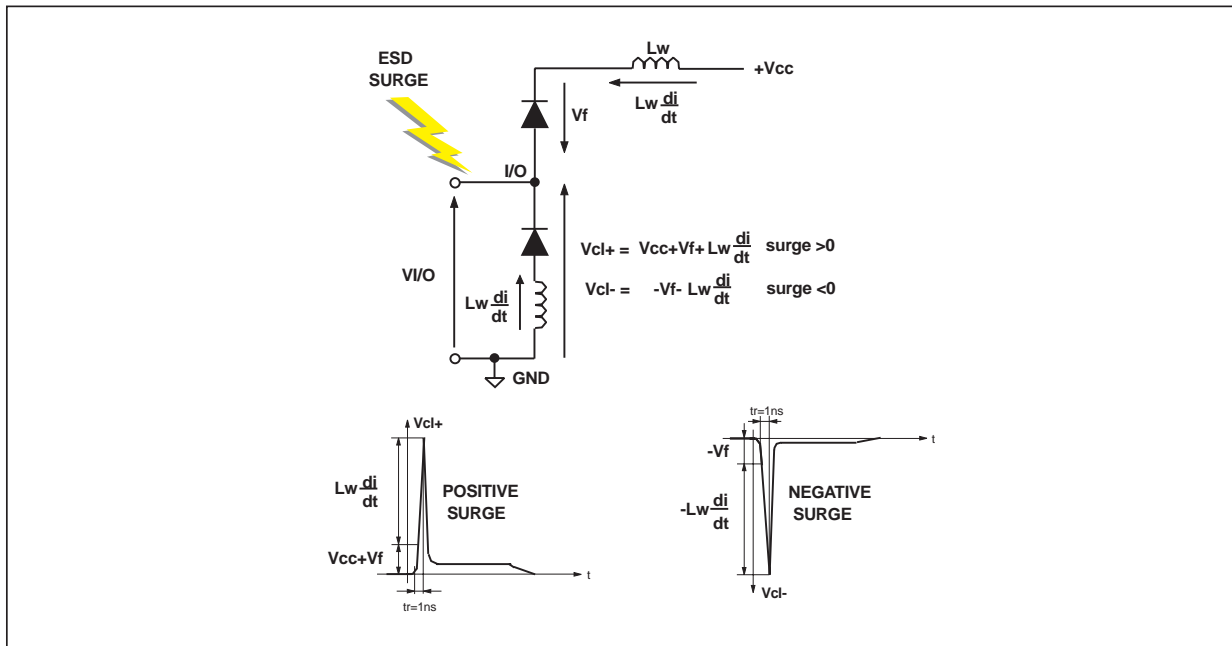

HOW TO ENSURE A GOOD ESD PROTECTION

While the USB6Bx provides a high immunity to ESD surge, an efficient protection depends on the layout of the board. In the same way, with the rail to rail topology, the track from the V_{CC} pin to the power supply and from the GND pin to GND voltage must be as short as possible to avoid overvoltages due to parasitic phenomena (see Fig A1).

It's often harder to connect the power supply near to the USB6Bx unlike the ground thanks to the ground plane that allows a short connection.

To ensure the same efficiency for positive surges when the connections can't be short enough, we recommend to put close to the USB6Bx between V_{CC} and ground, a capacitance of 100nF to prevent from these kinds of overvoltage disturbances (see Fig. A2).

The add of this capacitance will allow a better protection by providing during surge a constant voltage.

Fig. A3 shows the improvement of the ESD protection according to the recommendations described above.

Fig. A2: ESD behavior: optimized layout and add of a capacitance of 100nF.

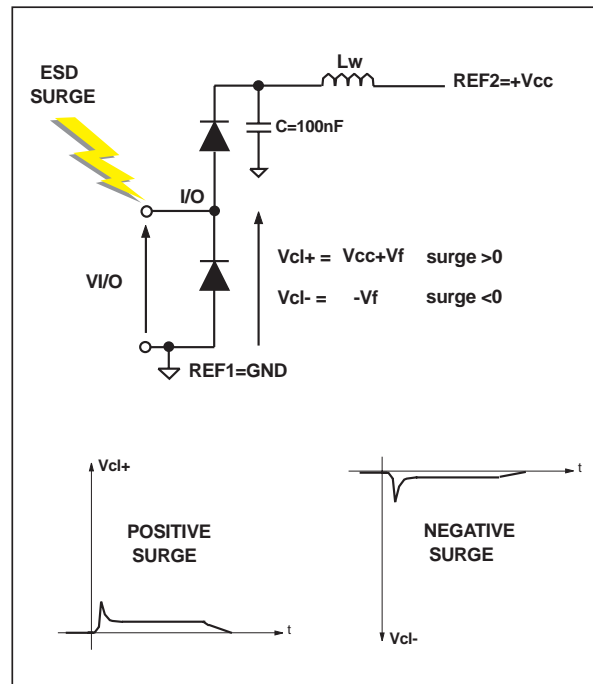

IMPORTANT:

A main precaution to take is to put the protection device closer to the disturbance source (generally the connection).

USB6Bx

TECHNICAL INFORMATION

Universal Serial Bus.

The new data transmission standard, Universal Serial Bus (USB) is being driven by market leaders in the world of Computer and Telecommunications, including Compaq, DEC, IBM, Intel, Microsoft, NEC and Nortel, and will become the leading transmission protocol within the next few years.

This standard mainly provides simplified interconnectivity. Specialized ports on the back of the present PC will largely be replaced by USB ports. Many peripherals such as printers, keyboards, monitors and joysticks will also host USB ports.

The USB offers high speed communication rates up to 12 Mbit/s. Only two wires (D+, D-) are required for data transfer. Additionally, limited amount of power for USB devices located on the

downstream can also be transmitted on two separate conductors within the same cable.

Protection to support USB.

Designers dealing with the USB chips are concerned about electrostatic discharge sensitivity (ESD) of their USB controller ICs.

The USB controller is more than just a driver / receiver; it acts as a microcontroller which manages power and direct signal traffic. This complexity increases its cost over conventional devices. Therefore, a failure of a USB port could result in costly computer failure.

In order to prevent these fast transients from leading to severe damages in a system, a specific protection has been developed by STMicroelectronics. The USB6Bx protects not only the two wires of data transmission, but also keep the power rails in a safe limit.

Fig. A3: recommended configuration for USB port protection.

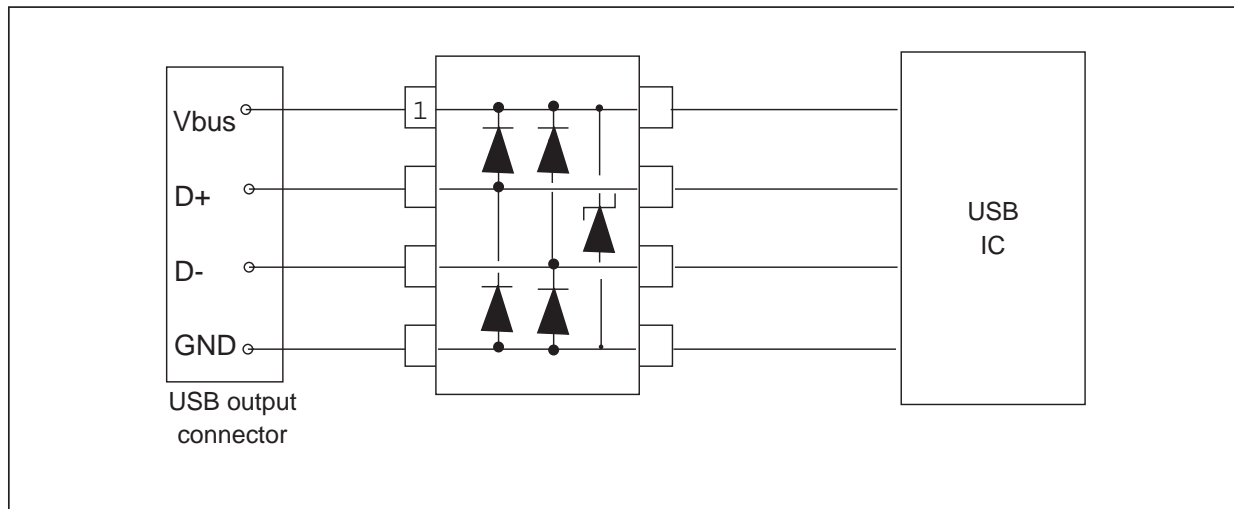

The capacitance between the I/O transmission wires provides no significant signal distortion at the 12 Mbit/s data rate, thus allowing full compatibility with USB standard.

Available either in a compact SO8 or in a through-hole DIL8 package, this protective element requires minimal board space and eases the PCB layout thanks to its direct compatibility with the USB connector pin-out.

TELECOM AND DATACOM APPLICATIONS

ISDN U interface protection.

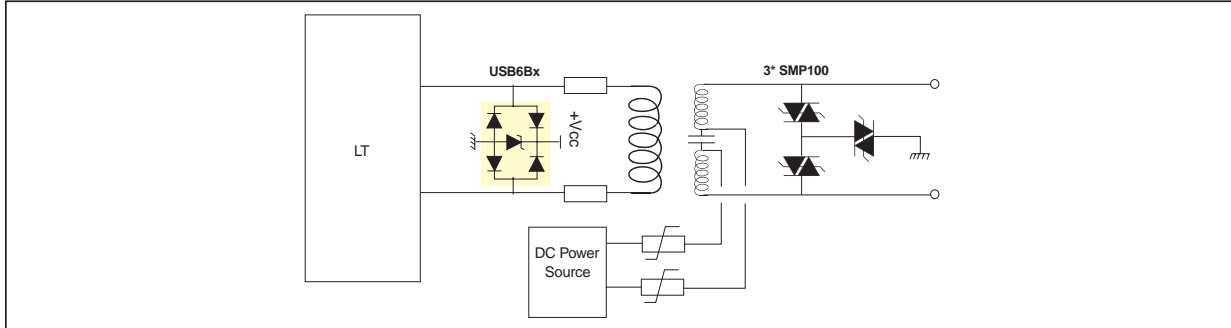

T1 / E1 Line Card Protection.

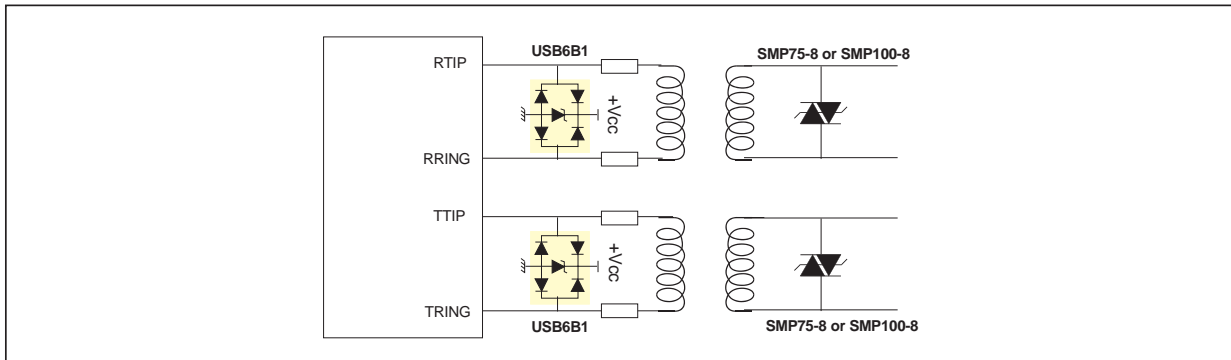

High Speed Line Driver / Receiver Protection.

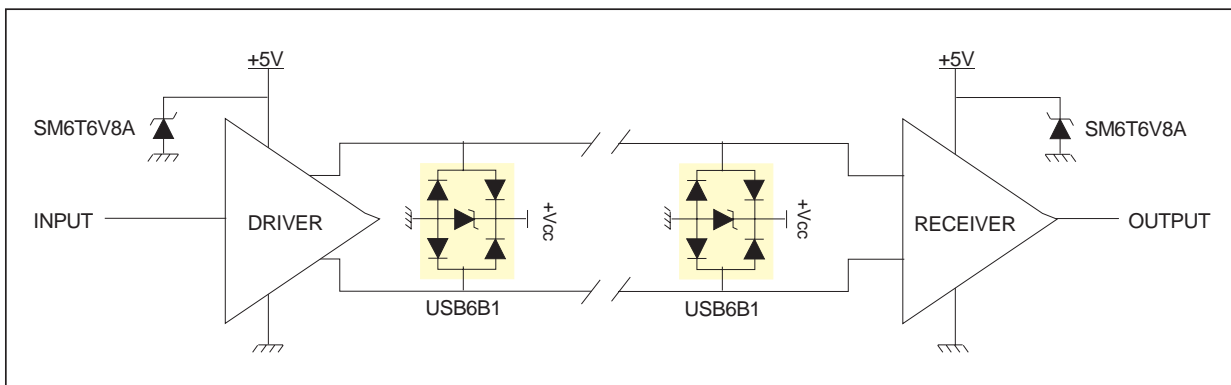

USB6Bx

ABSOLUTE MAXIMUM RATINGS ($T_{amb} = 25^{\circ}\text{C}$)

Symbol	Parameter		Value	Unit
V_{PP}	Peak pulse voltage	IEC1000-4-2 contact discharge IEC1000-4-2 air discharge MIL STD883C-Method 3015-6	8 15 4	kV
P_{PP}	Peak pulse power	8/20 μs	500	W
I_{PP}	Peak pulse current	8/20 μs	25	A
T_{stg} T_j	Storage temperature range Maximum junction temperature		- 55 to + 150 + 150	$^{\circ}\text{C}$ $^{\circ}\text{C}$
T_L	Lead solder temperature (10s duration)		260	$^{\circ}\text{C}$

ELECTRICAL CHARACTERISTICS ($T_{amb} = 25^{\circ}\text{C}$)

Symbol	Parameter		Value			Unit
			min.	typ.	max.	
V_{BR}	Breakdown voltage between V_{bus} and GND	$I_R=1\text{mA}$	6			V
I_{RM}	Leakage current	$V_{RM}=5.25\text{V}$			10	μA
C	Capacitance between pins D+ and D- $V_{OSC}=30\text{mV}$, $F=1\text{MHz}$, $V_R=0\text{V}$	V_{CC} not connected		15		pF
	Capacitance between pins D+ (or D-) and GND $V_{OSC}=30\text{mV}$, $F=1\text{MHz}$, $V_R=5\text{V}$	$V_{CC}=5\text{V}$		25		pF

Fig 1: Peak power dissipation versus initial junction temperature.

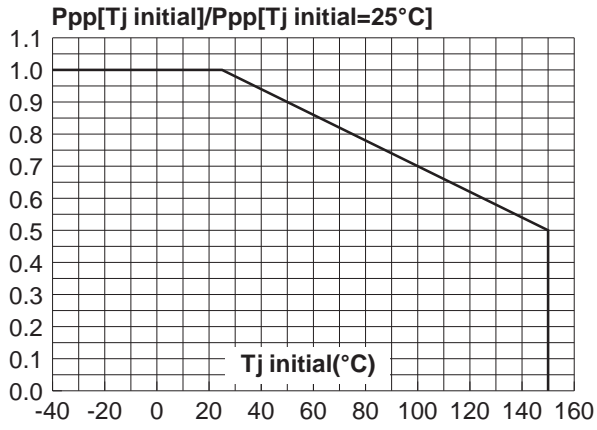

Fig 2: Relative variation of leakage current versus junction temperature (typical values).

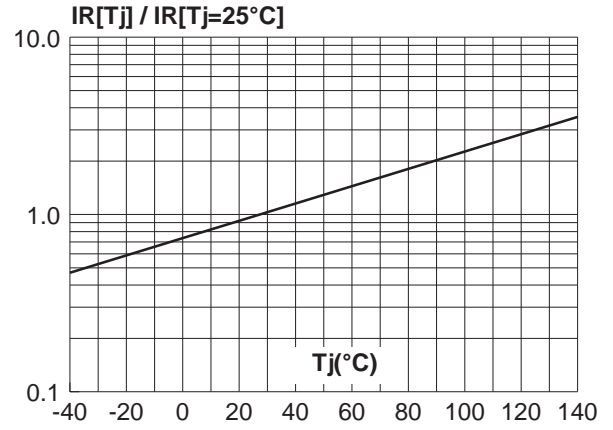
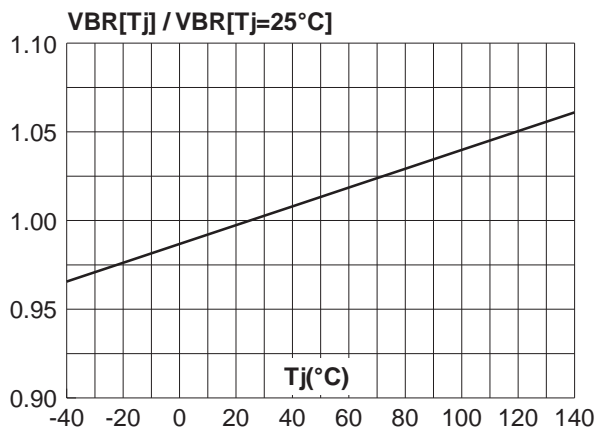

Fig 3: Relative variation of breakdown voltage versus junction temperature (typical values).



USB6Bx

ORDER CODE

<div style="display: flex; justify-content: space-around; font-weight: bold; font-size: 1.2em;"> USB 6 B1 RL </div> <div style="margin-top: 10px;"> <div style="display: flex; justify-content: space-around;"> <div style="text-align: center;"> <p>↓</p> <p>V_{BR} min</p> </div> <div style="text-align: center;"> <p>→</p> </div> </div> </div>	<p>PACKAGING: RL = tape and reel.(SO8 only) = tube</p> <p>PACKAGE: 1 = SO8 2 = DIL8</p>
---	---

PACKAGE MECHANICAL DATA.

SO8 Plastic

The drawings show the following dimensions:

- A**: Package height
- a1**: Lead thickness
- a2**: Lead height
- a3**: Lead width
- b**: Lead width
- b1**: Lead thickness
- C**: Lead thickness
- c1**: Lead angle
- D**: Package width
- E**: Package length
- e**: Lead pitch
- e3**: Lead pitch
- F**: Package width
- L**: Lead length
- M**: Lead length
- S**: Lead length

REF.	DIMENSIONS					
	Millimetres			Inches		
	Min.	Typ.	Max.	Min.	Typ.	Max.
A			1.75			0.069
a1	0.1		0.25	0.004		0.010
a2			1.65			0.065
a3	0.65		0.85	0.025		0.033
b	0.35		0.48	0.014		0.019
b1	0.19		0.25	0.007		0.010
C	0.25	0.50	0.50	0.010		0.020
c1	45° (typ)					
D	4.8		5.0	0.189		0.197
E	5.8		6.2	0.228		0.244
e		1.27			0.050	
e3		3.81			0.150	
F	3.8		4.0	0.15		0.157
L	0.4		1.27	0.016		0.050
M			0.6			0.024
S	8⊃ (max)					

PACKAGE MECHANICAL DATA.

DIL8 Plastic

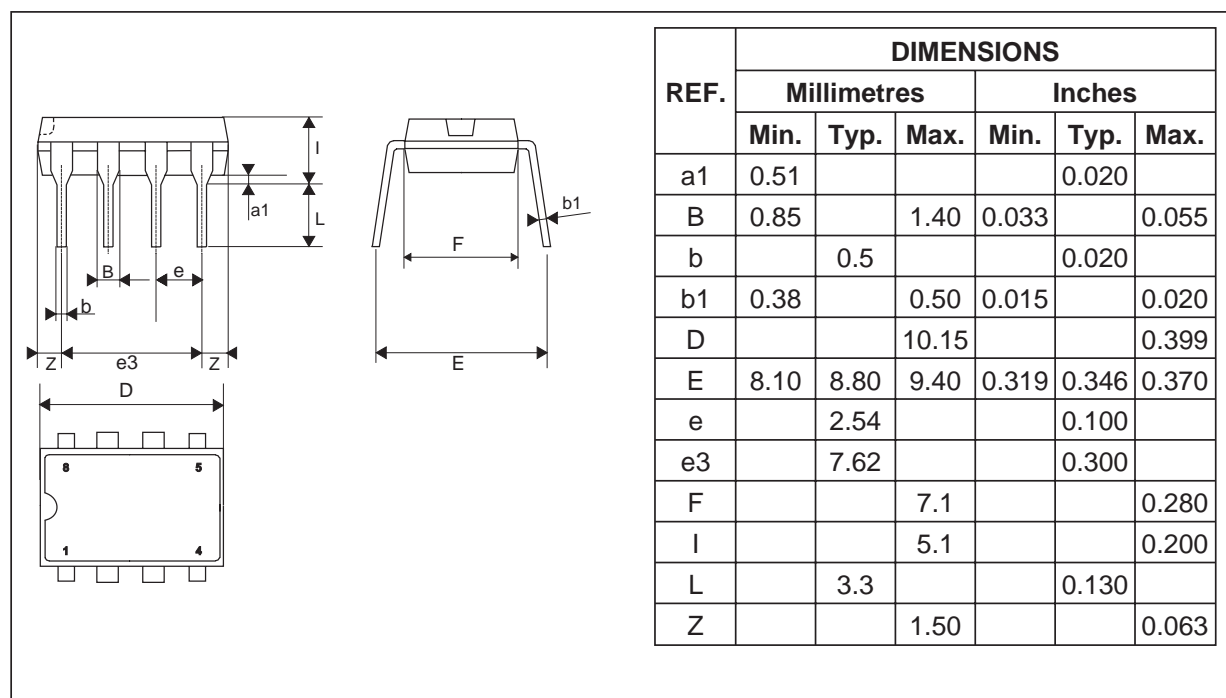
**MARKING**

Types	Package	Weight	Marking	ORDER CODE	Base Qty
USB6B1	SO8	0.077g	USB62	USB6B1	100 pcs (tube)
				USB6B1RL	2500 pcs (tape and reel)
USB6B2	DIL8	0.59g	USB62	USB6B2	50 pcs (tube)

- Epoxy meets UL94, V0

Information furnished is believed to be accurate and reliable. However, STMicroelectronics assumes no responsibility for the consequences of use of such information nor for any infringement of patents or other rights of third parties which may result from its use. No license is granted by implication or otherwise under any patent or patent rights of STMicroelectronics. Specifications mentioned in this publication are subject to change without notice. This publication supersedes and replaces all information previously supplied. STMicroelectronics products are not authorized for use as critical components in life support devices or systems without express written approval of STMicroelectronics.

The ST logo is a registered trademark of STMicroelectronics

© 1999 STMicroelectronics - Printed in Italy - All rights reserved.

STMicroelectronics GROUP OF COMPANIES

Australia - Brazil - China - Finland - France - Germany - Hong Kong - India - Italy - Japan - Malaysia
Malta - Morocco - Singapore - Spain - Sweden - Switzerland - United Kingdom - U.S.A.<http://www.st.com>