

---

---

## 4-Port SS/HS USB Controller Hub

---

---

### Highlights

- USB Hub Feature Controller IC with 4 USB 3.1 Gen 1 / USB 2.0 downstream ports
- USB-IF Battery Charger revision 1.2 support on up & downstream ports (DCP, CDP, SDP)
- **FlexConnect**: Downstream port able to swap with upstream port, allowing master capable devices to control other devices on the hub
- USB to I<sup>2</sup>C/UART/SPI/GPIO bridge endpoint support
- USB Link Power Management (LPM) support
- Enhanced OEM configuration options available through either OTP or SPI ROM
- Available in 64-pin (9 x 9 mm) VQFN lead-free, RoHS compliant package
- Commercial and industrial grade temperature support
- Configuration Straps: Predefined configuration of system level functions including GPIOs

### Target Applications

- Standalone USB Hubs
- Laptop Docks
- PC Motherboards
- PC Monitor Docks
- Multi-function USB 3.1 Gen 1 Peripherals

### Key Benefits

- USB 3.1 Gen 1 compliant 5 Gbps, 480 Mbps, 12 Mbps and 1.5 Mbps operation
  - 5 V tolerant USB 2.0 pins
  - 1.32 V tolerant USB 3.1 Gen 1 pins
  - Integrated termination & pull-up/pull-down resistors
- Supports per port battery charging of most popular battery powered devices
  - USB-IF Battery Charging rev. 1.2 support (DCP, CDP, SDP)
  - Apple<sup>®</sup> portable product charger emulation
  - Chinese YD/T 1591-2006 charger emulation
  - Chinese YD/T 1591-2009 charger emulation
  - European Union universal mobile charger support
  - Support for Microchip USC100x family of battery charging controllers
  - Supports additional portable devices
- Smart port controller operation
  - Firmware handling of companion port controllers
- On-chip microcontroller
  - Manages I/Os, VBUS, and other signals
- 8 KB RAM, 64 KB ROM
- 8 KB One Time Programmable (OTP) ROM
  - Includes on-chip charge pump
- Configuration programming via OTP ROM, SPI ROM, or SMBus
- **PortSwap**
  - Configurable differential intro-pair signal swapping
- **PHYBoost**<sup>™</sup>
  - Programmable USB transceiver drive strength for recovering signal integrity
- **VariSense**<sup>™</sup>
  - Programmable USB receiver sensitivity
- Compatible with Microsoft Windows 8, 7, XP, Apple OS X 10.4+, and Linux hub drivers
- Optimized for low-power operation and low thermal dissipation
- Package
  - 64-pin VQFN (9 x 9 mm)
- Environmental
  - 3 kV HBM JESD22-A114F ESD protection
  - Commercial temperature range (0°C to +70°C)
  - Industrial temperature range (-40°C to +85°C)

## TO OUR VALUED CUSTOMERS

It is our intention to provide our valued customers with the best documentation possible to ensure successful use of your Microchip products. To this end, we will continue to improve our publications to better suit your needs. Our publications will be refined and enhanced as new volumes and updates are introduced.

If you have any questions or comments regarding this publication, please contact the Marketing Communications Department via E-mail at [docerrors@microchip.com](mailto:docerrors@microchip.com). We welcome your feedback.

### Most Current Documentation

To obtain the most up-to-date version of this documentation, please register at our Worldwide Web site at:

<http://www.microchip.com>

You can determine the version of a data sheet by examining its literature number found on the bottom outside corner of any page. The last character of the literature number is the version number, (e.g., DS30000000A is version A of document DS30000000).

### Errata

An errata sheet, describing minor operational differences from the data sheet and recommended workarounds, may exist for current devices. As device/documentation issues become known to us, we will publish an errata sheet. The errata will specify the revision of silicon and revision of document to which it applies.

To determine if an errata sheet exists for a particular device, please check with one of the following:

- Microchip's Worldwide Web site; <http://www.microchip.com>
- Your local Microchip sales office (see last page)

When contacting a sales office, please specify which device, revision of silicon and data sheet (include -literature number) you are using.

### Customer Notification System

Register on our web site at [www.microchip.com](http://www.microchip.com) to receive the most current information on all of our products.

---

---

1.0 Preface .....	4
2.0 Introduction .....	6
3.0 Pin Description and Configuration .....	8
4.0 Device Connections .....	27
5.0 Modes of Operation .....	29
6.0 Device Configuration .....	32
7.0 Device Interfaces .....	34
8.0 Functional Descriptions .....	36
9.0 Operational Characteristics .....	42
10.0 Package Information .....	51

# USB5734

## 1.0 PREFACE

### 1.1 General Terms

TABLE 1-1: GENERAL TERMS

Term	Description
ADC	Analog-to-Digital Converter
Byte	8 bits
CDC	Communication Device Class
CSR	Control and Status Registers
DWORD	32 bits
EOP	End of Packet
EP	Endpoint
FIFO	First In First Out buffer
FS	Full-Speed
FSM	Finite State Machine
GPIO	General Purpose I/O
HS	Hi-Speed
HSOS	High Speed Over Sampling
Hub Feature Controller	The Hub Feature Controller, sometimes called a Hub Controller for short is the internal processor used to enable the unique features of the USB Controller Hub. This is not to be confused with the USB Hub Controller that is used to communicate the hub status back to the Host during a USB session.
I <sup>2</sup> C	Inter-Integrated Circuit
LS	Low-Speed
lsb	Least Significant Bit
LSB	Least Significant Byte
msb	Most Significant Bit
MSB	Most Significant Byte
N/A	Not Applicable
NC	No Connect
OTP	One Time Programmable
PCB	Printed Circuit Board
PCS	Physical Coding Sublayer
PHY	Physical Layer
PLL	Phase Lock Loop
RESERVED	Refers to a reserved bit field or address. Unless otherwise noted, reserved bits must always be zero for write operations. Unless otherwise noted, values are not guaranteed when reading reserved bits. Unless otherwise noted, do not read or write to reserved addresses.
SDK	Software Development Kit
SMBus	System Management Bus
UUID	Universally Unique Identifier
WORD	16 bits

## 1.2 Reference Documents

1. *UNICODE UTF-16LE For String Descriptors* USB Engineering Change Notice, December 29th, 2004, <http://www.usb.org>
2. *Universal Serial Bus Revision 3.1 Specification*, <http://www.usb.org>
3. *Battery Charging Specification*, Revision 1.2, Dec. 07, 2010, <http://www.usb.org>
4. *I<sup>2</sup>C-Bus Specification*, Version 1.1, <http://www.nxp.com>
5. *System Management Bus Specification*, Version 1.0, <http://smbus.org/specs>

# USB5734

---

## 2.0 INTRODUCTION

### 2.1 General Description

The Microchip USB5734 hub is low-power, OEM configurable, USB 3.1 Gen 1 hub feature controller with 4 downstream ports and advanced features for embedded USB applications. The USB5734 is fully compliant with the *Universal Serial Bus Revision 3.1 Specification* and *USB 2.0 Link Power Management Addendum*. The USB5734 supports 5 Gbps SuperSpeed (SS), 480 Mbps Hi-Speed (HS), 12 Mbps Full-Speed (FS), and 1.5 Mbps Low-Speed (LS) USB downstream devices on all enabled downstream ports.

The USB5734 supports the legacy USB speeds (HS/FS/LS) through a dedicated USB 2.0 hub feature controller that is the culmination of five generations of Microchip hub feature controller design and experience with proven reliability, interoperability, and device compatibility. The SuperSpeed hub feature controller operates in parallel with the USB 2.0 controller, decoupling the 5 Gbps SS data transfers from bottlenecks due to the slower USB 2.0 traffic.

The USB5734 enables OEMs to configure their system using “Configuration Straps.” These straps simplify the configuration process assigning default values to USB3.1 Gen 1 ports and GPIOs OEMs can disable ports, enable battery charging and define GPIO functions as default assignments on power up removing the need for OTP or external SPI ROM.

The USB5734 supports downstream battery charging. The USB5734 integrated battery charger detection circuitry supports the USB-IF Battery Charging (BC1.2) detection method and most Apple devices. The USB5734 provides the battery charging handshake and supports the following USB-IF BC1.2 charging profiles:

- DCP: Dedicated Charging Port (Power brick with no data)
- CDP: Charging Downstream Port (1.5A with data)
- SDP: Standard Downstream Port (0.5A with data)
- Custom profiles loaded via SMBus or OTP

The USB5734 provides an additional USB endpoint dedicated for use as a USB to I<sup>2</sup>C/UART/SPI/GPIO interface, allowing external circuits or devices to be monitored, controlled, or configured via the USB interface. Additionally, the USB5734 includes many powerful and unique features such as:

**FlexConnect**, which provides flexible connectivity options. One of the USB5734’s downstream ports can be reconfigured to become the upstream port, allowing master capable devices to control other devices on the hub.

**PortSwap**, which adds per-port programmability to USB differential-pair pin locations. PortSwap allows direct alignment of USB signals (D+/D-) to connectors to avoid uneven trace length or crossing of the USB differential signals on the PCB.

**PHYBoost**, which provides programmable levels of Hi-Speed USB signal drive strength in the downstream port transceivers. PHYBoost attempts to restore USB signal integrity in a compromised system environment. The graphic on the right shows an example of Hi-Speed USB eye diagrams before and after PHYBoost signal integrity restoration. in a compromised system environment

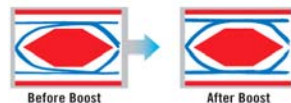

**VariSense**, which controls the USB receiver sensitivity enabling programmable levels of USB signal receive sensitivity. This capability allows operation in a sub-optimal system environment, such as when a captive USB cable is used.

The USB5734 can be configured for operation through internal default settings. Custom OEM configurations are supported through external SPI ROM or OTP ROM. All port control signal pins are under firmware control in order to allow for maximum operational flexibility, and are available as GPIOs for customer specific use.

The USB5734 is available in commercial (0°C to +70°C) and industrial (-40°C to +85°C) temperature ranges. An internal block diagram of the USB5734 is shown in [Figure 2-1](#).

FIGURE 2-1: INTERNAL BLOCK DIAGRAM

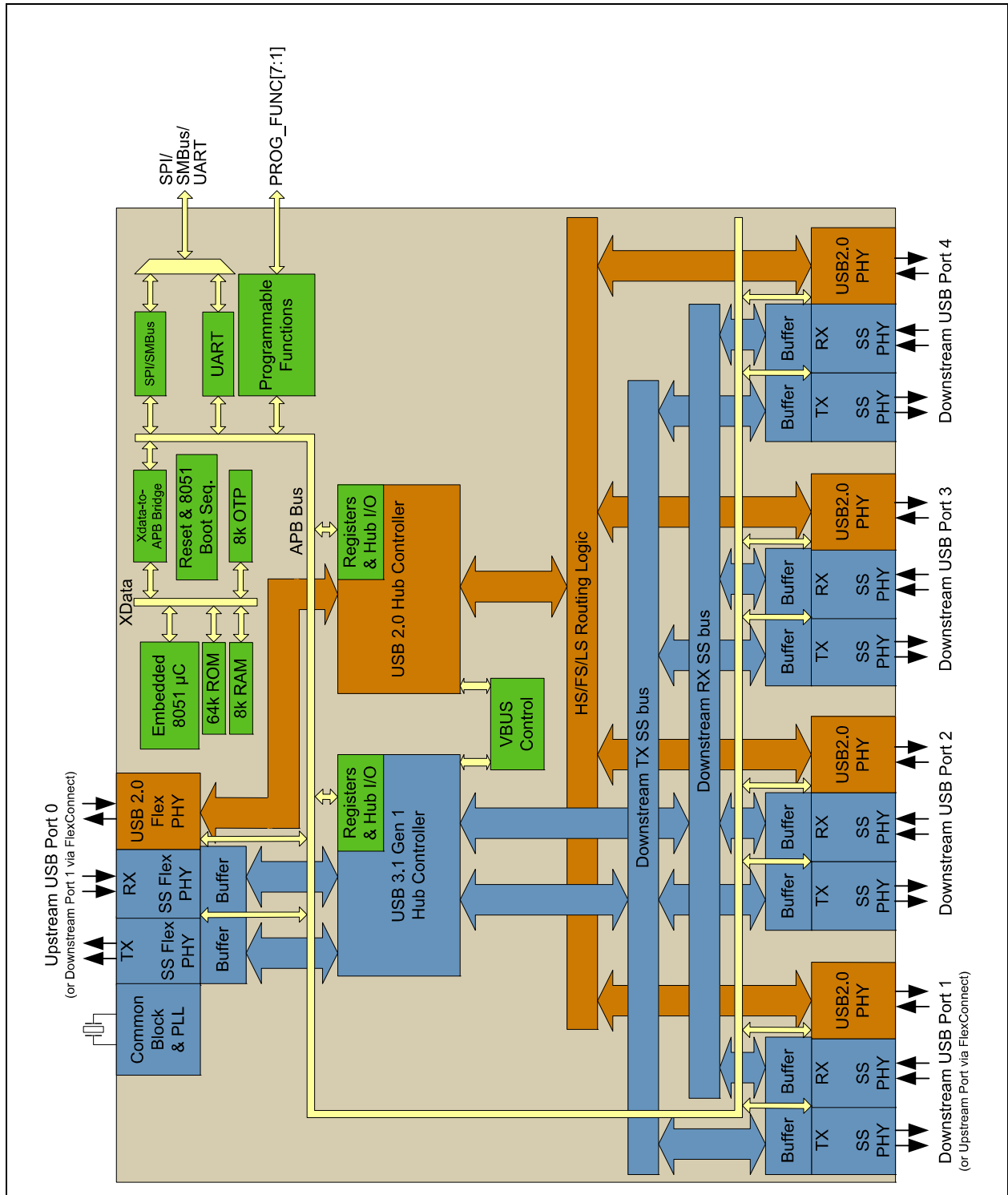

# USB5734

## 3.0 PIN DESCRIPTION AND CONFIGURATION

### 3.1 Pin Assignments

FIGURE 3-1: 64-VQFN PIN ASSIGNMENTS

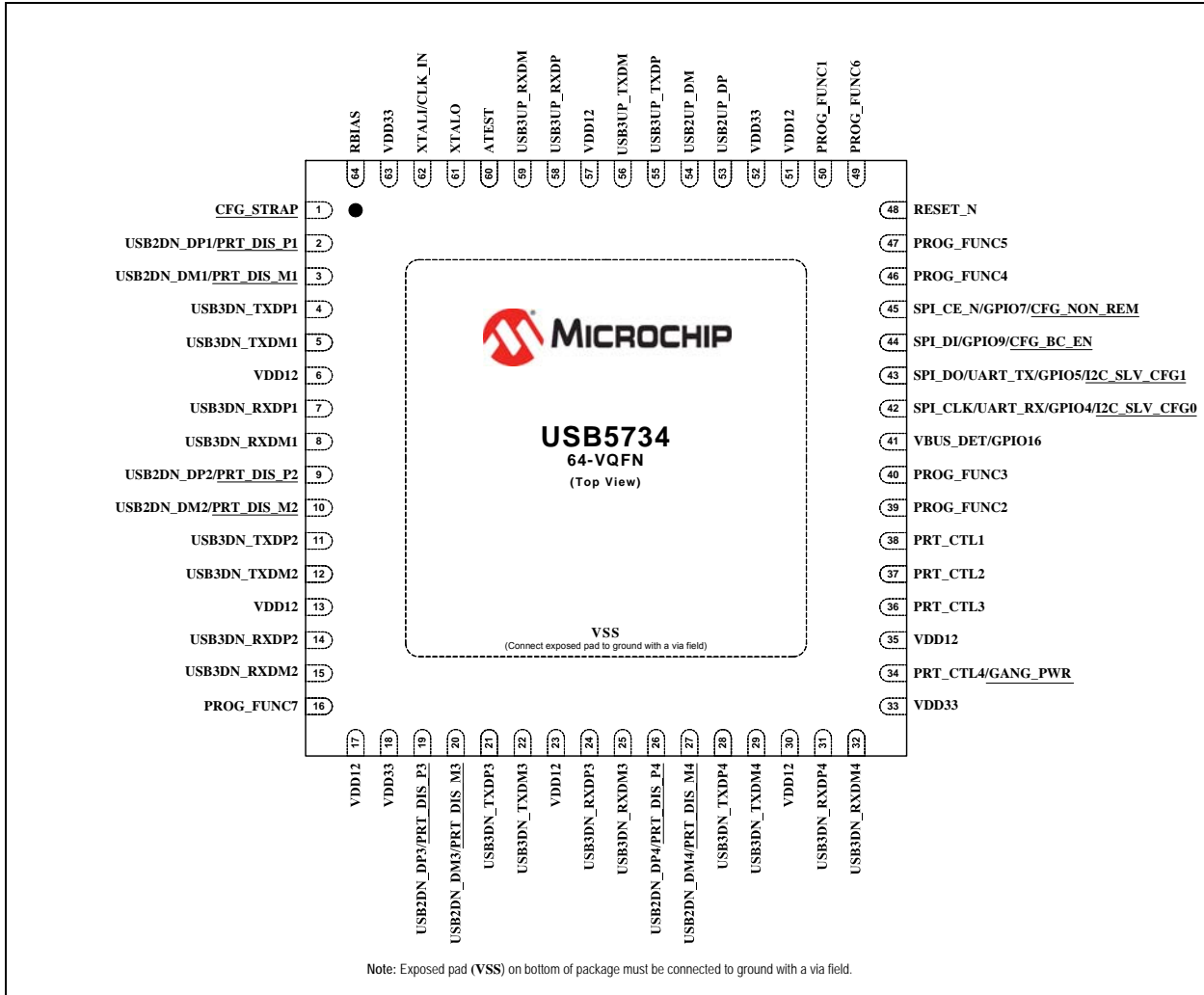

**Note 1:** Configuration straps are identified by an underlined symbol name. Signals that function as configurations traps must be augmented with an external resistor when connected to a load. Refer to [Section 3.4, "Configuration Straps and Programmable Functions"](#) for additional information.



Table 3-1 details the package pin assignments in table format.

**TABLE 3-1: 64-VQFN PIN ASSIGNMENTS**

Pin Number	Pin Name	Pin Number	Pin Name
1	<u>CFG_STRAP</u>	33	VDD33
2	USB2DN_DP1/ <u>PRT_DIS_P1</u>	34	<u>PRT_CTL4/GANG_PWR</u>
3	USB2DN_DM1/ <u>PRT_DIS_M1</u>	35	VDD12
4	USB3DN_TXDP1	36	PRT_CTL3
5	USB3DN_TXDM1	37	PRT_CTL2
6	VDD12	38	PRT_CTL1
7	USB3DN_RXDP1	39	PROG_FUNC2
8	USB3DN_RXDM1	40	PROG_FUNC3
9	USB2DN_DP2/ <u>PRT_DIS_P2</u>	41	VBUS_DET/GPIO16
10	USB2DN_DM2/ <u>PRT_DIS_M2</u>	42	<u>SPI_CLK/UART_RX/GPIO4/I2C_SLV_CFG0</u>
11	USB3DN_TXDP2	43	<u>SPI_DO/UART_TX/GPIO5/I2C_SLV_CFG1</u>
12	USB3DN_TXDM2	44	<u>SPI_DI/GPIO9/CFG_BC_EN</u>
13	VDD12	45	<u>SPI_CE_N/GPIO7/CFG_NON_REM</u>
14	USB3DN_RXDP2	46	PROG_FUNC4
15	USB3DN_RXDM2	47	PROG_FUNC5
16	PROG_FUNC7	48	RESET_N
17	VDD12	49	PROG_FUNC6
18	VDD33	50	PROG_FUNC1
19	USB2DN_DP3/ <u>PRT_DIS_P3</u>	51	VDD12
20	USB2DN_DM3/ <u>PRT_DIS_M3</u>	52	VDD33
21	USB3DN_TXDP3	53	USB2UP_DP
22	USB3DN_TXDM3	54	USB2UP_DM
23	VDD12	55	USB3UP_TXDP
24	USB3DN_RXDP3	56	USB3UP_TXDM
25	USB3DN_RXDM3	57	VDD12
26	USB2DN_DP4/ <u>PRT_DIS_P4</u>	58	USB3UP_RXDP
27	USB2DN_DM4/ <u>PRT_DIS_M4</u>	59	USB3UP_RXDM
28	USB3DN_TXDP4	60	ATEST
29	USB3DN_TXDM4	61	XTALO
30	VDD12	62	XTALI/CLK_IN
31	USB3DN_RXDP4	63	VDD33
32	USB3DN_RXDM4	64	RBIAS

# USB5734

TABLE 3-2: 56-VQFN PIN ASSIGNMENTS

1	USB2DN_DP1/ <u>PRT_DIS_P1</u>	29	NC
2	USB2DN_DM1/ <u>PRT_DIS_M1</u>	30	NC
3	USB3DN_TXDP1	31	VDD33
4	USB3DN_TXDM1	32	GPIO20/ <u>GANG_PWR</u>
5	VDD12	33	VDD12
6	USB3DN_RXDP1	34	GPIO19
7	USB3DN_RXDM1	35	PRT_CTL2
8	USB2DN_DP2/ <u>PRT_DIS_P2</u>	36	PRT_CTL1
9	USB2DN_DM2/ <u>PRT_DIS_M2</u>	37	VBUS_DET
10	USB3DN_TXDP2	38	SPI_CLK/SMCLK
11	USB3DN_TXDM2	39	SPI_DO/SMDAT
12	VDD12	40	SPI_DI/ <u>CFG_BC_EN</u>
13	USB3DN_RXDP2	41	SPI_CE_N/ <u>CFG_NON_REM</u>
14	USB3DN_RXDM2	42	RESET_N
15	VDD12	43	VDD12
16	VDD33	44	VDD33
17	NC	45	USB2UP_DP
18	NC	46	USB2UP_DM
19	NC	47	USB3UP_TXDP
20	NC	48	USB3UP_TXDM
21	VDD12	49	VDD12
22	NC	50	USB3UP_RXDP
23	NC	51	USB3UP_RXDM
24	NC	52	ATEST
25	NC	53	XTALO
26	NC	54	XTALI/CLK_IN
27	NC	55	VDD33
28	VDD12	56	RBIAS

## 3.2 Pin Descriptions

This section contains descriptions of the various USB5734 pins. This pin descriptions have been broken into functional groups as follows:

- [USB 3.1 Gen 1 Pin Descriptions](#)
- [USB 2.0 Pin Descriptions](#)
- [USB Port Control Pin Descriptions](#)
- [SPI/UART Pin Descriptions](#)
- [Programmable Function Pin Descriptions](#)
- [Miscellaneous Pin Descriptions](#)
- [Power and Ground Pin Descriptions](#)

The “\_N” symbol in the signal name indicates that the active, or asserted, state occurs when the signal is at a low voltage level. For example, **RESET\_N** indicates that the reset signal is active low. When “\_N” is not present after the signal name, the signal is asserted when at the high voltage level.

The terms assertion and negation are used exclusively. This is done to avoid confusion when working with a mixture of “active low” and “Active high” signals. The term assert, or assertion, indicates that a signal is active, independent of whether that level is represented by a high or low voltage. The term negate, or negation, indicates that a signal is inactive.

**Note:** The buffer type for each signal is indicated in the “Buffer Type” column of the pin description tables. A description of the buffer types is provided in [Section 3.3, "Buffer Types," on page 16](#). For additional information on configuration straps and configurable pins, refer to [Section 3.4, "Configuration Straps and Programmable Functions"](#).

**TABLE 3-3: USB 3.1 GEN 1 PIN DESCRIPTIONS**

Num Pins	Symbol	Buffer Type	Description
1	USB3UP_TXDP	IO-U	USB 3.1 Gen 1 upstream SuperSpeed transmit data plus.
1	USB3UP_TXDM	IO-U	USB 3.1 Gen 1 upstream SuperSpeed transmit data minus.
1	USB3UP_RXDP	IO-U	USB 3.1 Gen 1 upstream SuperSpeed receive data plus.
1	USB3UP_RXDM	IO-U	USB 3.1 Gen 1 upstream SuperSpeed receive data minus.
4	USBDN_TXDP[4:1]	IO-U	USB 3.1 Gen 1 downstream ports 4-1 SuperSpeed transmit data plus.
4	USBDN_TXDM[4:1]	IO-U	USB 3.1 Gen 1 downstream ports 4-1 SuperSpeed transmit data minus.
4	USBDN_RXDP[4:1]	IO-U	USB 3.1 Gen 1 downstream ports 4-1 SuperSpeed receive data plus.
4	USBDN_RXDM[4:1]	IO-U	USB 3.1 Gen 1 downstream ports 4-1 SuperSpeed receive data minus.

**TABLE 3-4: USB 2.0 PIN DESCRIPTIONS**

Num Pins	Symbol	Buffer Type	Description
1	USB2UP_DP	IO-U	USB 2.0 upstream data plus (D+).
1	USB2UP_DM	IO-U	USB 2.0 upstream data minus (D-).

# USB5734

**TABLE 3-4: USB 2.0 PIN DESCRIPTIONS (CONTINUED)**

Num Pins	Symbol	Buffer Type	Description
4	USB2DN_DP[4:1]	IO-U	USB 2.0 downstream ports 4-1 data plus (D+).
	<u>PRT_DIS_P[4:1]</u>	I	Port 4-1 D+ Disable Configuration Strap.  These configuration straps are used in conjunction with the corresponding <u>PRT_DIS_M[4:1]</u> straps to disable the related port (4-1). Refer to <a href="#">Section 3.4.2, "Port Disable Configuration (PRT_DIS_P[4:1] / PRT_DIS_M[4:1])"</a> for more information.  See <a href="#">Note 2</a> .
4	USB2DN_DM[4:1]	IO-U	USB 2.0 downstream ports 4-1 data minus (D-).
	<u>PRT_DIS_M[4:1]</u>	I	Port 4-1 D- Disable Configuration Strap.  These configuration straps are used in conjunction with the corresponding <u>PRT_DIS_P[4:1]</u> straps to disable the related port (4-1). Refer to <a href="#">Section 3.4.2, "Port Disable Configuration (PRT_DIS_P[4:1] / PRT_DIS_M[4:1])"</a> for more information.  See <a href="#">Note 2</a> .
1	VBUS_DET	IS	This signal detects the state of the upstream bus power.  When designing a detachable hub, this pin must be connected to the VBUS power pin of the upstream USB port through a resistor divider (50 kΩ by 100 kΩ) to provide 3.3 V.  For self-powered applications with a permanently attached host, this pin must be connected to either 3.3 V or 5.0 V through a resistor divider to provide 3.3 V.  In embedded applications, <b>VBUS_DET</b> may be controlled (toggled) when the host desires to renegotiate a connection without requiring a full reset of the device.
	GPIO16	I/O6	General purpose input/output 16.

**Note 2:** Configuration strap values are latched on Power-On Reset (POR) and the rising edge of **RESET\_N** (external chip reset). Configuration straps are identified by an underlined symbol name. Signals that function as configurations traps must be augmented with an external resistor when connected to a load. Refer to [Section 3.4, "Configuration Straps and Programmable Functions"](#) for additional information.

**TABLE 3-5: USB PORT CONTROL PIN DESCRIPTIONS**

Num Pins	Symbol	Buffer Type	Description
1	PRT_CTL1	I (PU)	Port 1 Power Enable / Overcurrent Sense.  As an output, this signal is an active high control signal used to enable power to the downstream port 1. As an input, this signal indicates an overcurrent condition from an external current monitor on USB port 1.
1	PRT_CTL2	I (PU)	Port 2 Power Enable / Overcurrent Sense.  As an output, this signal is an active high control signal used to enable power to the downstream port 2. As an input, this signal indicates an overcurrent condition from an external current monitor on USB port 2.

**TABLE 3-5: USB PORT CONTROL PIN DESCRIPTIONS (CONTINUED)**

Num Pins	Symbol	Buffer Type	Description
1	PRT_CTL3	I (PU)	Port 3 Power Enable / Overcurrent Sense.  As an output, this signal is an active high control signal used to enable power to the downstream port 3. As an input, this signal indicates an overcurrent condition from an external current monitor on USB port 3.
1	PRT_CTL4	I (PU)	Port 4 Power Enable / Overcurrent Sense.  As an output, this signal is an active high control signal used to enable power to the downstream port 4. As an input, this signal indicates an overcurrent condition from an external current monitor on USB port 4.
	<u>GANG_PWR</u>	I (PU)	When pulled high enables gang mode. Gang power pin when used in gang mode.

**TABLE 3-6: SPI/UART PIN DESCRIPTIONS**

Num Pins	Symbol	Buffer Type	Description
1	SPI_CE_N	O12	Active low SPI chip enable output.
	GPIO7	I/O12	General purpose input/output 7.
	<u>CFG_NON_REM</u>	I	Non-Removable Port Configuration Strap.  This configuration strap is used to configure the number of non-removable ports. Refer to <a href="#">Section 3.4.3, "Non-Removable Port Configuration (CFG_NON_REM)"</a> for more information.  See <a href="#">Note 3</a> .
1	SPI_CLK	O6	SPI clock output to the serial ROM, when configured for SPI operation.
	UART_RX	I	UART receive pin, when configured for UART operation.
	GPIO4	I/O6	General purpose input/output 4.
	<u>I2C_SLV_CFG0</u>	I	I <sup>2</sup> C Slave 0 Configuration Strap.  This configuration strap is used to configure I <sup>2</sup> C controller 0. Refer to <a href="#">Section 3.4.1, "SPI/SMBus/I2C/UART Configuration (I2C_SLV_CFG[1:0])"</a> for additional information.
1	SPI_DO	O6	SPI data output, when configured for SPI operation.
	UART_TX	O12	UART transmit pin, when configured for UART operation.
	GPIO5	I/O6	General purpose input/output 5.
	<u>I2C_SLV_CFG1</u>	I	I <sup>2</sup> C Slave 1 Configuration Strap.  This configuration strap is used to configure I <sup>2</sup> C controller 1. Refer to <a href="#">Section 3.4.1, "SPI/SMBus/I2C/UART Configuration (I2C_SLV_CFG[1:0])"</a> for additional information.

# USB5734

**TABLE 3-6: SPI/UART PIN DESCRIPTIONS (CONTINUED)**

Num Pins	Symbol	Buffer Type	Description
1	<b>SPI_DI</b>	IS	SPI data input, when configured for SPI operation.
	<b>GPIO9</b>	I/O12	General purpose input/output 9.
	<b><u>CFG_BC_EN</u></b>	I	Battery Charging Configuration Strap.  This configuration strap is used to enable battery charging. Refer to <a href="#">Section 3.4.4, "Battery Charging Configuration (CFG_BC_EN)"</a> for more information.  See <a href="#">Note 3</a> .

**Note 3:** Configuration strap values are latched on Power-On Reset (POR) and the rising edge of **RESET\_N** (external chip reset). Configuration straps are identified by an underlined symbol name. Signals that function as configurations traps must be augmented with an external resistor when connected to a load. Refer to [Section 3.4, "Configuration Straps and Programmable Functions"](#) for additional information.

**TABLE 3-7: PROGRAMMABLE FUNCTION PIN DESCRIPTIONS**

Num Pins	Symbol	Buffer Type	Description
7	<b>PROG_FUNC[7:1]</b>	<a href="#">Note 4</a>	Programmable function pins 7-1.  The functions of these pins are configured via the <b><u>CFG_STRAP</u></b> pin. Refer to <a href="#">Section 3.4.5, "Device Mode / PROG_FUNC[7:1] Configuration (CFG_STRAP)"</a> for additional information.
1	<b><u>CFG_STRAP</u></b>	I	Device Mode Configuration Strap.  This configuration strap is used to set the device mode. Refer to <a href="#">Section 3.4.5, "Device Mode / PROG_FUNC[7:1] Configuration (CFG_STRAP)"</a> for more information.  See <a href="#">Note 5</a> .

**Note 4:** The **PROG\_FUNC2** buffer type is I/O6. The **PROG\_FUNC7** buffer type is I/O10. All other **PROG\_FUNCx** pins have a buffer type of I/O12.

**Note 5:** Configuration strap values are latched on Power-On Reset (POR) and the rising edge of **RESET\_N** (external chip reset). Configuration straps are identified by an underlined symbol name. Signals that function as configurations traps must be augmented with an external resistor when connected to a load. Refer to [Section 3.4, "Configuration Straps and Programmable Functions"](#) for additional information.

**TABLE 3-8: MISCELLANEOUS PIN DESCRIPTIONS**

Num Pins	Symbol	Buffer Type	Description
1	RESET_N	IS	The RESET_N pin puts the device into Reset Mode, as the name of the pin and function then align.
1	XTALI	ICLK	External 25 MHz crystal input
	CLK_IN	ICLK	External reference clock input. The device may alternatively be driven by a single-ended clock oscillator. When this method is used, XTALO should be left unconnected.
1	XTALO	OCLK	External 25 MHz crystal output
1	RBIAS	AI	A 12.0 k $\Omega$ (+/- 1%) resistor is attached from ground to this pin to set the transceiver's internal bias settings.
1	ATEST	AI	Analog test pin.
			This signal is used for test purposes and must always be connected to ground.

**TABLE 3-9: POWER AND GROUND PIN DESCRIPTIONS**

Num Pins	Symbol	Buffer Type	Description
4	VDD33	P	+3.3 V power and internal regulator input Refer to <a href="#">Section 4.1, "Power Connections"</a> for power connection information.
8	VDD12	P	+1.2 V core power Refer to <a href="#">Section 4.1, "Power Connections"</a> for power connection information.
Pad	VSS	P	Common ground. This exposed pad must be connected to the ground plane with a via array.

# USB5734

## 3.3 Buffer Types

TABLE 3-10: BUFFER TYPES

Buffer Type	Description
I	Input
IS	Schmitt-triggered input
O6	Output with 6 mA sink and 6 mA source
O10	Output with 10 mA sink and 10 mA source
O12	Output with 12 mA sink and 12 mA source
OD12	Open-drain output with 12 mA sink
PU	50 $\mu$ A (typical) internal pull-up. Unless otherwise noted in the pin description, internal pull-ups are always enabled. Internal pull-up resistors prevent unconnected inputs from floating. Do not rely on internal resistors to drive signals external to the device. When connected to a load that must be pulled high, an external resistor must be added.
PD	50 $\mu$ A (typical) internal pull-down. Unless otherwise noted in the pin description, internal pull-downs are always enabled. Internal pull-down resistors prevent unconnected inputs from floating. Do not rely on internal resistors to drive signals external to the device. When connected to a load that must be pulled low, an external resistor must be added.
IO-U	Analog input/output as defined in USB specification
AI	Analog input
ICLK	Crystal oscillator input pin
OCLK	Crystal oscillator output pin
P	Power pin

**Note:** Refer to [Section 9.5, "DC Specifications"](#) for individual buffer DC electrical characteristics.



## 3.4 Configuration Straps and Programmable Functions

Configuration straps are multi-function pins that are used during Power-On Reset (POR) or external chip reset (**RESET\_N**) to determine the default configuration of a particular feature. The state of the signal is latched following de-assertion of the reset. Configuration straps are identified by an underlined symbol name. This section details the various device configuration straps and associated programmable pin functions.

**Note:** The system designer must guarantee that configuration straps meet the timing requirements specified in [Section 9.6.2, "Power-On and Configuration Strap Timing," on page 46](#) and [Section 9.6.3, "Reset and Configuration Strap Timing," on page 47](#). If configuration straps are not at the correct voltage level prior to being latched, the device may capture incorrect strap values.

### 3.4.1 SPI/SMBUS/I<sup>2</sup>C/UART CONFIGURATION (I2C SLV CFG[1:0])

The SPI/SMBus/I<sup>2</sup>C/UART pins can be configured into one of four functional modes:

- SPI Mode
- SMBus Slave Enable Mode
- I<sup>2</sup>C Bridging Mode
- UART Mode

If 10 kΩ pull-up resistors are detected on **SPI\_DO** and **SPI\_CLK**, the SPI/SMBus/I<sup>2</sup>C/UART pins are configured into SMBus Slave Enable Mode. If a 10 kΩ pull-down resistor is detected on **SPI\_DO**, the SPI/SMBus/I<sup>2</sup>C/UART pins are configured into UART Mode. If no pull-ups or pull-downs are detected on **SPI\_DO** and **SPI\_CLK**, the SPI/SMBus/I<sup>2</sup>C/UART pins are first configured into SPI Mode. If no valid SPI ROM is detected, the SPI/SMBus/I<sup>2</sup>C/UART pins are configured into I<sup>2</sup>C Bridging Mode. The strap settings for these supported modes are detailed in [Table 3-11](#). The individual pin function assignments for each mode are detailed in [Table 3-12](#). For additional device connection information, refer to [Section 4.0, "Device Connections"](#).

**Note:** The following interfaces cannot be used simultaneously:

- UART and SMBus Slave
- UART and SPI
- SMBus Slave and I<sup>2</sup>C Bridging interface

**TABLE 3-11: SPI/SMBUS/I<sup>2</sup>C/UART MODE CONFIGURATION SETTINGS**

Pin	SPI Mode ( <a href="#">Note 6</a> )	SMBus Slave Enable Mode ( <a href="#">Note 7</a> )	I <sup>2</sup> C Bridging Mode ( <a href="#">Note 8</a> )	UART Mode
43 ( <b>SPI_DO</b> )	No pull-up/down	10 kΩ pull-up	No pull-up/down	10 kΩ pull-down
42 ( <b>SPI_CLK</b> )	No pull-up/down	10 kΩ pull-up	No pull-up/down	No pull-up/down

**Note 6:** In order to use the SPI interface, an SPI ROM containing a valid signature of 2DFU (device firmware upgrade) beginning at address 0xFFFFA must be present. Refer to [Section 7.1, "SPI Master Interface"](#) for additional information.

**Note 7:** In order to use the SMBus slave interface, the **SPI\_DO** and **SPI\_CLK** pins must be configured for SMBus Slave Enable Mode and **CFG\_STRAP** must be configured to Configuration 1, 2, 3, or 6, which programs the **PROG\_FUNC4** and **PROG\_FUNC5** pins as **SMDAT** and **SMCLK**, respectively. When in Configuration 4 or 5, the SMBus slave interface is not usable. Refer to [Section 3.4.5, "Device Mode / PROG\\_FUNC\[7:1\] Configuration \(CFG\\_STRAP\)"](#) for additional information.

**Note 8:** In order to use the I<sup>2</sup>C Bridging interface, the **SPI\_DO** and **SPI\_CLK** pins must be configured for I<sup>2</sup>C Bridging Mode and **CFG\_STRAP** must be configured to Configuration 1, 2, 3, or 6, which programs the **PROG\_FUNC4** and **PROG\_FUNC5** pins as **SMDAT** and **SMCLK**, respectively. When in Configuration 4 or 5, the I<sup>2</sup>C Bridging interface is not usable. Additional hub register configuration is also required. Refer to [Section 3.4.5, "Device Mode / PROG\\_FUNC\[7:1\] Configuration \(CFG\\_STRAP\)"](#) and [Section 7.3, "I<sup>2</sup>C Bridge Interface"](#) for additional information.

# USB5734

**TABLE 3-12: SPI/SMBUS/I<sup>2</sup>C/UART MODE PIN ASSIGNMENTS**

Pin	SPI Mode	SMBus Slave Enable Mode	I <sup>2</sup> C Bridging Mode	UART Mode
45	SPI_CE_N	<u>CFG_NON_REM</u>	<u>CFG_NON_REM</u>	<u>CFG_NON_REM</u>
44	SPI_DI	<u>CFG_BC_EN</u>	<u>CFG_BC_EN</u>	<u>CFG_BC_EN</u>
43	SPI_DO	<u>I2C_SLV_CFG0</u>	-	UART_TX
42	SPI_CLK	<u>I2C_SLV_CFG1</u>	-	UART_RX

### 3.4.2 PORT DISABLE CONFIGURATION (PRT\_DIS\_P[4:1] / PRT\_DIS\_M[4:1])

The PRT\_DIS\_P[4:1] and PRT\_DIS\_M[4:1] configuration straps are used in conjunction to disable the related port (4-1).

For PRT\_DIS\_P<sub>x</sub> (where x is the corresponding port 4-1):

0 = Port x D+ Enabled

1 = Port x D+ Disabled

For PRT\_DIS\_M<sub>x</sub> (where x is the corresponding port 4-1):

0 = Port x D- Enabled

1 = Port x D- Disabled

**Note:** Both PRT\_DIS\_P<sub>x</sub> and PRT\_DIS\_M<sub>x</sub> (where x is the corresponding port) must be tied to 3.3 V to disable the associated downstream port. Disabling the USB 2.0 port will also disable the corresponding USB 3.1 Gen 1 port.

### 3.4.3 NON-REMOVABLE PORT CONFIGURATION (CFG\_NON\_REM)

The CFG\_NON\_REM configuration strap is used to configure the non-removable port settings of the device to one of five settings. These modes are selected by the configuration of an external resistor on the CFG\_NON\_REM pin. The resistor options are a 200 kΩ pull-down, 200 kΩ pull-up, 10 kΩ pull-down, 10 kΩ pull-up, and 10 Ω pull-down, as shown in [Table 3-13](#).

**TABLE 3-13: CFG\_NON\_REM RESISTOR ENCODING**

<u>CFG_NON_REM</u> Resistor Value	Setting
200 kΩ Pull-Down	All ports removable
200 kΩ Pull-Up	Port 1 non-removable
10 kΩ Pull-Down	Port 1, 2 non-removable
10 kΩ Pull-Up	Port 1, 2, 3, non-removable
10 Ω Pull-Down	Port 1, 2, 3, 4 non-removable

## 3.4.4 BATTERY CHARGING CONFIGURATION (CFG\_BC\_EN)

The CFG\_BC\_EN configuration strap is used to configure the battery charging port settings of the device to one of five settings. These modes are selected by the configuration of an external resistor on the CFG\_BC\_EN pin. The resistor options are a 200 k $\Omega$  pull-down, 200 k $\Omega$  pull-up, 10 k $\Omega$  pull-down, 10 k $\Omega$  pull-up, and 10  $\Omega$  pull-down, as shown in [Table 3-14](#).

**TABLE 3-14: CFG\_BC\_EN RESISTOR ENCODING**

<u>CFG_BC_EN</u> Resistor Value	Setting
200 k $\Omega$ Pull-Down	No battery charging
200 k $\Omega$ Pull-Up	Port 1 battery charging
10 k $\Omega$ Pull-Down	Port 1, 2 battery charging
10 k $\Omega$ Pull-Up	Port 1, 2, 3, battery charging
10 $\Omega$ Pull-Down	Port 1, 2, 3, 4 battery charging

## 3.4.5 DEVICE MODE / PROG\_FUNC[7:1] CONFIGURATION (CFG\_STRAP)

The CFG\_STRAP is used to configure the programmable function pins (PROG\_FUNC[7:1]) into one of six modes. These modes are selected by the configuration of an external resistor on the CFG\_STRAP pin. The resistor options are a 200 k $\Omega$  pull-down, 200 k $\Omega$  pull-up, 10 k $\Omega$  pull-down, 10 k $\Omega$  pull-up, 10  $\Omega$  pull-down, and 10  $\Omega$  pull-up, as shown in [Table 3-15](#). For details on each device mode, including pin assignments, refer to the following subsections.

**TABLE 3-15: CFG\_STRAP RESISTOR ENCODING**

<u>CFG_STRAP</u> Resistor Value	Mode
200 k $\Omega$ Pull-Down	<a href="#">Configuration 1 - Mixed Mode</a>
200 k $\Omega$ Pull-Up	<a href="#">Configuration 2 - FlexConnect Mode</a>
10 k $\Omega$ Pull-Down	<a href="#">Configuration 3 - Speed Indicator Mode</a>
10 k $\Omega$ Pull-Up	<a href="#">Configuration 4 - GPIO Mode (Reserved)</a>
10 $\Omega$ Pull-Down	<a href="#">Configuration 5 - Battery Charging / Power Delivery Indicator Mode</a>
10 $\Omega$ Pull-Up	<a href="#">Configuration 6 - Full UART Mode</a>

# USB5734

## 3.4.5.1 Configuration 1 - Mixed Mode

When the **CFG\_STRAP** is configured to this mode, the programmable function pins (**PROG\_FUNC[7:1]**) are set to provide an SMBus/I<sup>2</sup>C interface, 3 GPIOs, and FlexConnect capabilities. [Table 3-16](#) details the **PROG\_FUNC[7:1]** pin assignments in this mode.

**TABLE 3-16: CONFIGURATION 1 PROG\_FUNC[7:1] FUNCTION ASSIGNMENT**

Pin	Function	Buffer Type	Description
PROG_FUNC1	GPIO1	I/O12	<b>General Purpose Input/Output 1</b>
PROG_FUNC2	GPIO2	I/O6	<b>General Purpose Input/Output 2</b>
PROG_FUNC3	GPIO3	I/O12	<b>General Purpose Input/Output 3</b>
PROG_FUNC4	SMDAT	OD12	<b>SMBus/I<sup>2</sup>C Data</b> The SMBus/I <sup>2</sup> C interface acts as SMBus slave or I <sup>2</sup> C bridge dependent on the device configuration. Refer to <a href="#">Section 3.4.1</a> , " <a href="#">SPI/SMBus/I2C/UART Configuration (I2C_SLV_CFG[1:0])</a> ".
PROG_FUNC5	SMCLK	OD12	<b>SMBus/I<sup>2</sup>C Clock</b> The SMBus/I <sup>2</sup> C interface acts as SMBus slave or I <sup>2</sup> C bridge dependent on the device configuration. Refer to <a href="#">Section 3.4.1</a> , " <a href="#">SPI/SMBus/I2C/UART Configuration (I2C_SLV_CFG[1:0])</a> ".
PROG_FUNC6	FLEXCMD	IS	<b>FlexConnect Control</b> 0: Normal Operation (Port 0 upstream, Port 1 downstream) 1: Flex Operation (Port 1 upstream, Port 0 downstream) <b>Note:</b> Refer to <a href="#">Section 8.2</a> , " <a href="#">FlexConnect</a> " for additional information.
PROG_FUNC7	USB2_SUSP_IND	O10	<b>USB2.0 Suspend Indicator</b> USB2_SUSP_IND can be used as a sideband remote wakeup signal for the host when in USB2.0 suspend. <b>Note:</b> Refer to <a href="#">Section 8.5</a> , " <a href="#">Remote Wakeup Indicator</a> " for additional information.

## 3.4.5.2 Configuration 2 - FlexConnect Mode

When the **CFG\_STRAP** is configured to this mode, the programmable function pins (**PROG\_FUNC[7:1]**) are set to provide FlexConnect, an SMBus/I<sup>2</sup>C interface, and other additional features. [Table 3-17](#) details the **PROG\_FUNC[7:1]** pin assignments in this mode.

**TABLE 3-17: CONFIGURATION 2 PROG\_FUNC[7:1] FUNCTION ASSIGNMENT**

Pin	Function	Buffer Type	Description
PROG_FUNC1	HOST_TYPE0	O12	<p><b>Port 0 USB Host Type</b>            Tri-state: No USB host detected on Port 0            0: USB 3.1 Gen 1 Host detected on Port 0            1: USB 2.0 or USB 1.1 Host detected on Port 0</p> <p>A USB 2.0 Host is considered detected when the USB 2.0 hub address register holds a non-zero value. A USB 3.1 Gen 1 Host is considered detected when the USB 3.1 Gen 1 hub address register holds a non-zero value.</p>
PROG_FUNC2	HOST_TYPE1	O6	<p><b>Port 1 USB Host Type</b>            Tri-state: No USB host detected on Port 1            0: USB 3.1 Gen 1 Host detected on Port 1            1: USB 2.0 or USB 1.1 Host detected on Port 1</p> <p>A USB 2.0 Host is considered detected when the USB 2.0 hub address register holds a non-zero value. A USB 3.1 Gen 1 Host is considered detected when the USB 3.1 Gen 1 hub address register holds a non-zero value.</p>
PROG_FUNC3	FLEX_STATE_N	O12	<p><b>FlexConnect State Compliment Indicator</b>            This signal reflects the inverse of the current state of FLEX-CMD.            0: Flex Operation (Port 1 upstream, Port 0 downstream)            1: Normal Operation (Port 0 upstream, Port 1 downstream)</p> <p><b>Note:</b> Refer to <a href="#">Section 8.2, "FlexConnect"</a> for additional information.</p>
PROG_FUNC4	SMDAT	OD12	<p><b>SMBus/I<sup>2</sup>C Data</b>            The SMBus/I<sup>2</sup>C interface acts as SMBus slave or I<sup>2</sup>C bridge dependent on the device configuration. Refer to <a href="#">Section 3.4.1, "SPI/SMBus/I2C/UART Configuration (I2C_SLV_CFG[1:0])"</a>.</p>
PROG_FUNC5	SMCLK	OD12	<p><b>SMBus/I<sup>2</sup>C Clock</b>            The SMBus/I<sup>2</sup>C interface acts as SMBus slave or I<sup>2</sup>C bridge dependent on the device configuration. Refer to <a href="#">Section 3.4.1, "SPI/SMBus/I2C/UART Configuration (I2C_SLV_CFG[1:0])"</a>.</p>
PROG_FUNC6	FLEXCMD	IS	<p><b>FlexConnect Control</b>            0: Normal Operation (Port 0 upstream, Port 1 downstream)            1: Flex Operation (Port 1 upstream, Port 0 downstream)</p> <p><b>Note:</b> Refer to the <a href="#">Section 8.2, "FlexConnect"</a> for additional information.</p>
PROG_FUNC7	FLEX_STATE	O10	<p><b>FlexConnect State Indicator</b>            This signal reflects the current state of FLEXCMD.            0: Normal Operation (Port 0 upstream, Port 1 downstream)            1: Flex Operation (Port 1 upstream, Port 0 downstream)</p> <p><b>Note:</b> Refer to <a href="#">Section 8.2, "FlexConnect"</a> for additional information.</p>

# USB5734

## 3.4.5.3 Configuration 3 - Speed Indicator Mode

When the **CFG\_STRAP** is configured to this mode, the programmable function pins (**PROG\_FUNC[7:1]**) are set to indicate speed status, host type, and provide an SMBus/I<sup>2</sup>C interface. [Table 3-18](#) details the **PROG\_FUNC[7:1]** pin assignments in this mode.

**TABLE 3-18: CONFIGURATION 3 PROG\_FUNC[7:1] FUNCTION ASSIGNMENT**

Pin	Function	Buffer Type	Description
PROG_FUNC1	SPEED_IND1	O12	<b>Port 1 Speed Indicator</b> Tri-state: Not connected 0: USB 2.0 / USB 1.1 1: USB 3.1 Gen 1
PROG_FUNC2	SPEED_IND2	O6	<b>Port 2 Speed Indicator</b> Tri-state: Not connected 0: USB 2.0 / USB 1.1 1: USB 3.1 Gen 1
PROG_FUNC3	SPEED_IND3	O12	<b>Port 3 Speed Indicator</b> Tri-state: Not connected 0: USB 2.0 / USB 1.1 1: USB 3.1 Gen 1
PROG_FUNC4	SMDAT	OD12	<b>SMBus/I<sup>2</sup>C Data</b> The SMBus/I <sup>2</sup> C interface acts as SMBus slave or I <sup>2</sup> C bridge dependent on the device configuration. Refer to <a href="#">Section 3.4.1</a> , " <a href="#">SPI/SMBus/I2C/UART Configuration (I2C_SLV_CFG[1:0])</a> ".
PROG_FUNC5	SMCLK	OD12	<b>SMBus/I<sup>2</sup>C Clock</b> The SMBus/I <sup>2</sup> C interface acts as SMBus slave or I <sup>2</sup> C bridge dependent on the device configuration. Refer to <a href="#">Section 3.4.1</a> , " <a href="#">SPI/SMBus/I2C/UART Configuration (I2C_SLV_CFG[1:0])</a> ".
PROG_FUNC6	SPEED_IND4	O12	<b>Port 4 Speed Indicator</b> Tri-state: Not connected 0: USB 2.0 / USB 1.1 1: USB 3.1 Gen 1
PROG_FUNC7	HOST_TYPE	O10	<b>Port 0 USB Host Type</b> Tri-state: No USB host detected on Port 0 0: USB 3.1 Gen 1 Host detected on Port 0 1: USB 2.0 or USB 1.1 Host detected on Port 0  A USB 2.0 Host is considered detected when the USB 2.0 hub address register holds a non-zero value. A USB 3.1 Gen 1 Host is considered detected when the USB 3.1 Gen 1 hub address register holds a non-zero value.

**FIGURE 3-2: CONFIGURATION 3 PROG\_FUNC[7:1] PIN CONNECTIONS**

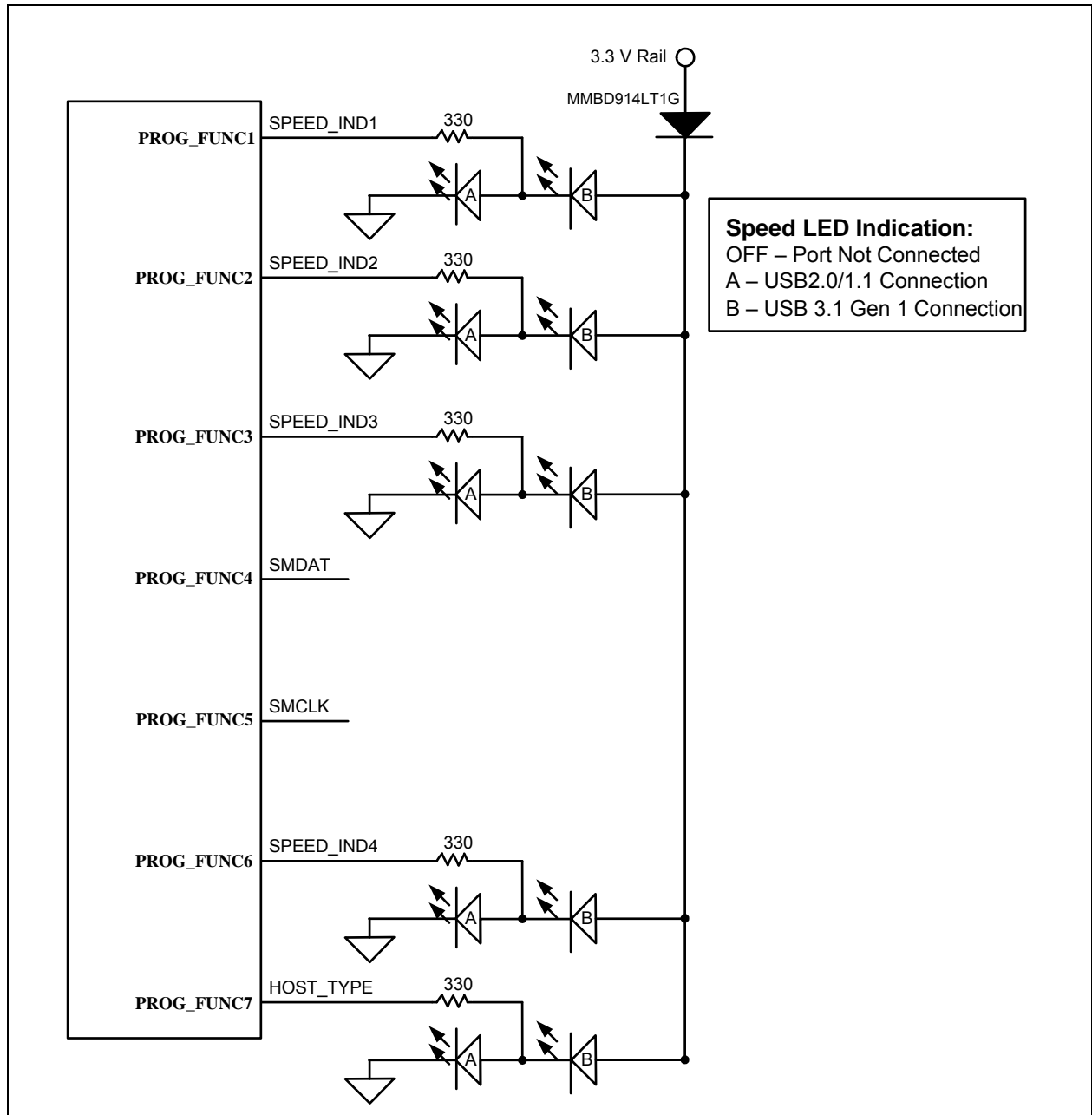

# USB5734

## 3.4.5.4 Configuration 4 - GPIO Mode (Reserved)

When the **CFG\_STRAP** is configured to this mode, the programmable function pins (**PROG\_FUNC[7:1]**) are set to provide 7 general purpose I/Os that can be used for GPIO bridging. [Table 3-19](#) details the **PROG\_FUNC[7:1]** pin assignments in this mode.

**TABLE 3-19: CONFIGURATION 4 PROG\_FUNC[7:1] FUNCTION ASSIGNMENT**

Pin	Function	Buffer Type	Description
PROG_FUNC1	GPIO1	I/O12	General Purpose Input/Output 1
PROG_FUNC2	GPIO2	I/O6	General Purpose Input/Output 2
PROG_FUNC3	GPIO3	I/O12	General Purpose Input/Output 3
PROG_FUNC4	GPIO6	I/O12	General Purpose Input/Output 4
PROG_FUNC5	GPIO8	I/O12	General Purpose Input/Output 5
PROG_FUNC6	GPIO10	I/O12	General Purpose Input/Output 6
PROG_FUNC7	GPIO11	I/O10	General Purpose Input/Output 7

## 3.4.5.5 Configuration 5 - Battery Charging / Power Delivery Indicator Mode

When the **CFG\_STRAP** is configured to this mode, the programmable function pins (**PROG\_FUNC[7:1]**) are set to indicate battery charging and 3 general purpose I/Os. [Table 3-20](#) details the **PROG\_FUNC[7:1]** pin assignments in this mode.

**TABLE 3-20: CONFIGURATION 5 PROG\_FUNC[7:1] FUNCTION ASSIGNMENT**

Pin	Function	Buffer Type	Description
PROG_FUNC1	BC_IND1	O12	<b>Port 1 Battery Charging Indicator</b> Tri-state: Battery Charging not enabled 0: In BC 1.2 Mode 1: Battery Charging enabled
PROG_FUNC2	BC_IND2	O6	<b>Port 2 Battery Charging Indicator</b> Tri-state: Battery Charging not enabled 0: In BC 1.2 Mode 1: Battery Charging enabled
PROG_FUNC3	BC_IND3	O12	<b>Port 3 Battery Charging Indicator</b> Tri-state: Battery Charging not enabled 0: In BC 1.2 Mode 1: Battery Charging enabled
PROG_FUNC4	BC_IND4	O12	<b>Port 4 Battery Charging Indicator</b> Tri-state: Battery Charging not enabled 0: In BC 1.2 Mode 1: Battery Charging enabled
PROG_FUNC5	GPIO8	I/O12	General Purpose Input/Output 8
PROG_FUNC6	GPIO10	I/O12	General Purpose Input/Output 10
PROG_FUNC7	GPIO11	I/O10	General Purpose Input/Output 11



**FIGURE 3-3: CONFIGURATION 5 PROG\_FUNC[7:1] PIN CONNECTIONS**

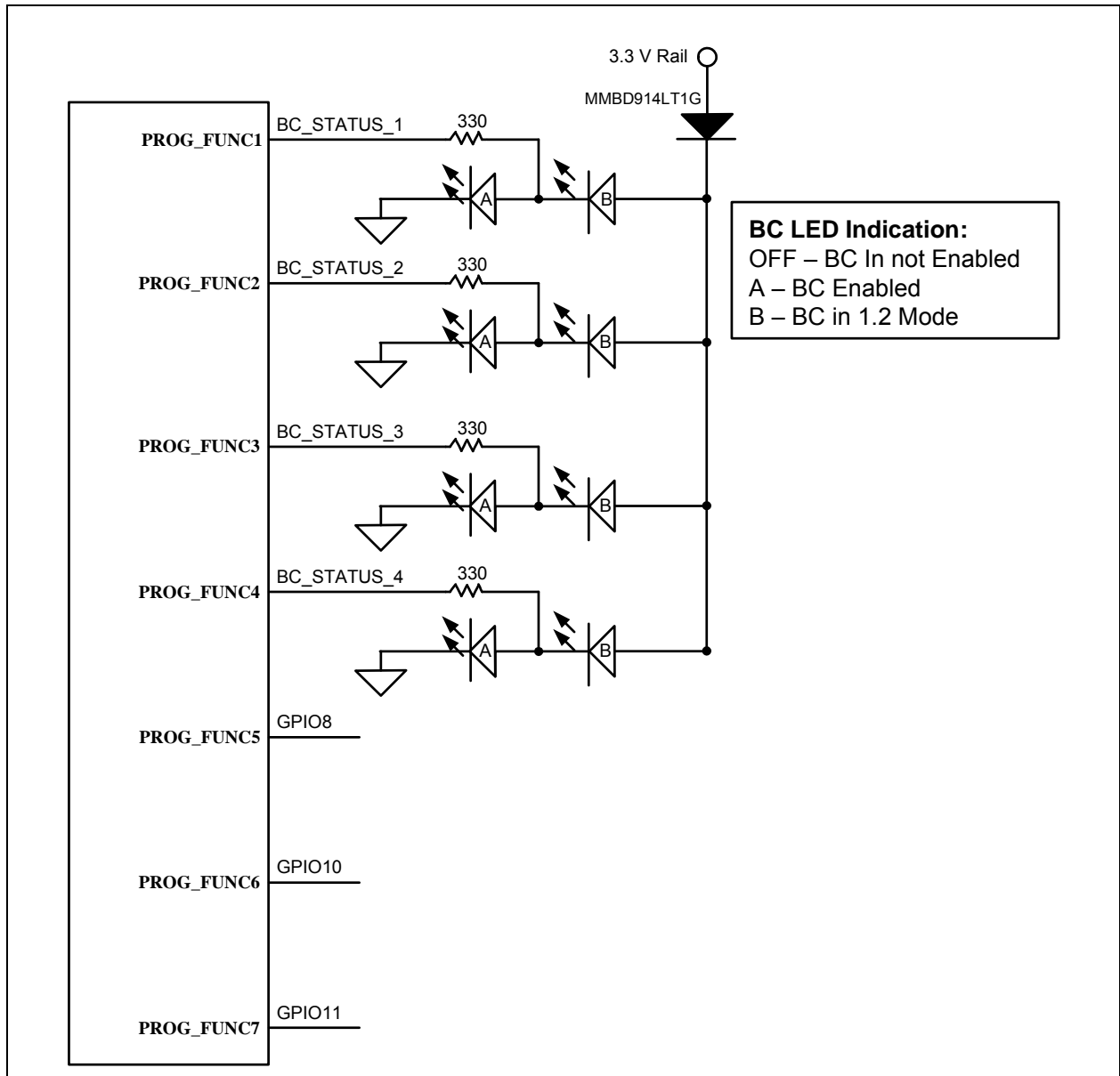

# USB5734

## 3.4.5.6 Configuration 6 - Full UART Mode

When the **CFG\_STRAP** is configured to this mode, the programmable function pins (**PROG\_FUNC[7:1]**) are set for full UART configuration and also provide an SMBus/I<sup>2</sup>C interface. In this mode the **PROG\_FUNCx** pins are used in conjunction with the **UART\_TX** and **UART\_RX** pins for a full UART interface. [Table 3-21](#) details the **PROG\_FUNC[7:1]** pin assignments in this mode.

**Note:** When flow control is disabled, **UART\_nCTS**, **UART\_nDCD**, and **UART\_nDSR** must not be left floating. In this case, these pins should include external pull-downs to maintain UART communication in Full UART Mode with no flow control.

**TABLE 3-21: CONFIGURATION 6 PROG\_FUNC[7:1] FUNCTION ASSIGNMENT**

Pin	Function	Buffer Type	Description
<b>PROG_FUNC1</b>	UART_nRTS	I/O12	<b>UART Request To Send</b>
<b>PROG_FUNC2</b>	UART_nCTS	I/O6	<b>UART Clear To Send</b>
<b>PROG_FUNC3</b>	UART_nDCD	I/O12	<b>UART Data Carrier Detect</b>
<b>PROG_FUNC4</b>	SMDAT	OD12	<b>SMBus/I<sup>2</sup>C Data</b> The SMBus/I <sup>2</sup> C interface acts as SMBus slave or I <sup>2</sup> C bridge dependent on the device configuration. Refer to <a href="#">Section 3.4.1</a> , " <a href="#">SPI/SMBus/I2C/UART Configuration (I2C_SLV_CFG[1:0])</a> ".
<b>PROG_FUNC5</b>	SMCLK	OD12	<b>SMBus/I<sup>2</sup>C Clock</b> The SMBus/I <sup>2</sup> C interface acts as SMBus slave or I <sup>2</sup> C bridge dependent on the device configuration. Refer to <a href="#">Section 3.4.1</a> , " <a href="#">SPI/SMBus/I2C/UART Configuration (I2C_SLV_CFG[1:0])</a> ".
<b>PROG_FUNC6</b>	UART_nDTR	I/O12	<b>UART Data Terminal Ready</b>
<b>PROG_FUNC7</b>	UART_nDSR	I/O10	<b>UART Data Set Ready</b>

## 4.0 DEVICE CONNECTIONS

### 4.1 Power Connections

Figure 4-1 illustrates the device power connections.

**FIGURE 4-1: POWER CONNECTIONS**

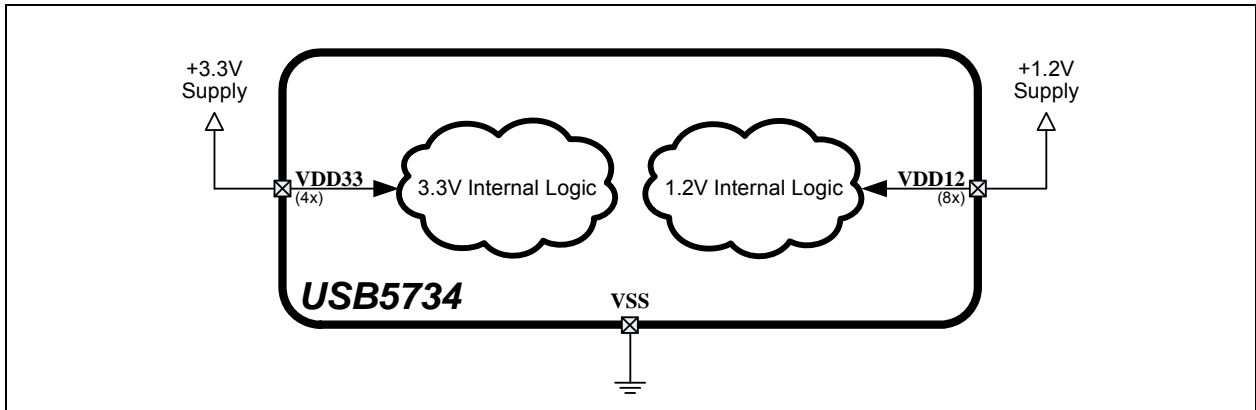

### 4.2 SPI ROM Connections

Figure 4-2 illustrates the device SPI ROM connections. Refer to Section 7.1, "SPI Master Interface," on page 34 for additional information on this device interface.

**FIGURE 4-2: SPI ROM CONNECTIONS**

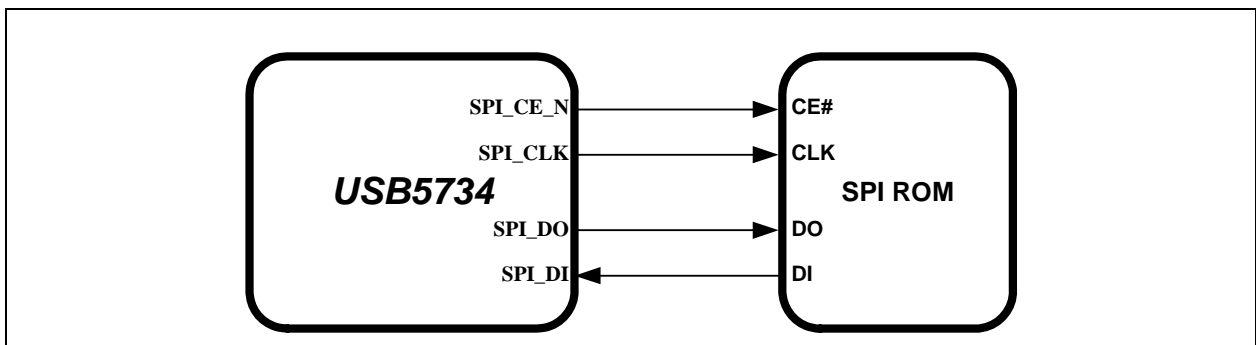

# USB5734

## 4.3 SMBus Slave Connections

Figure 4-3 illustrates the device SMBus slave connections. Refer to [Section 7.2, "SMBus Slave Interface,"](#) on page 34 for additional information on this device interface.

FIGURE 4-3: SMBUS SLAVE CONNECTIONS

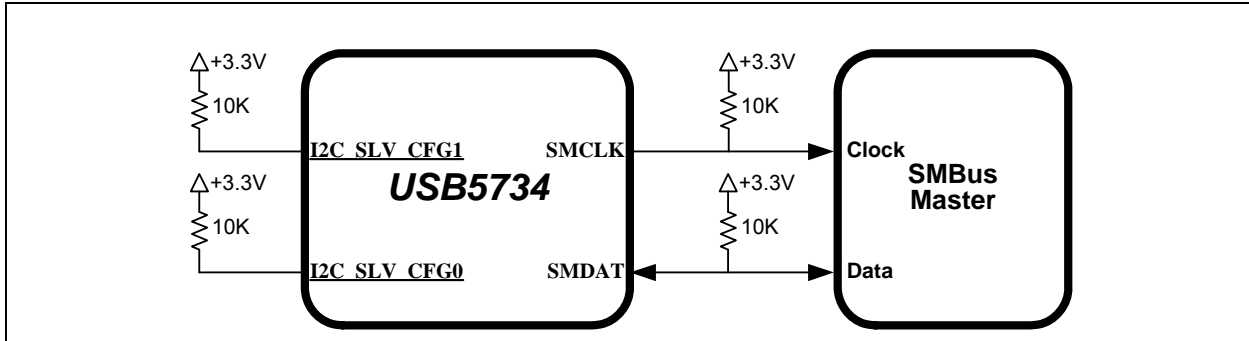

## 4.4 I<sup>2</sup>C Bridge Connections

Figure 4-4 illustrates the device I<sup>2</sup>C bridge connections. Refer to [Section 7.3, "I<sup>2</sup>C Bridge Interface,"](#) on page 34 for additional information on this device interface.

FIGURE 4-4: I<sup>2</sup>C BRIDGE CONNECTIONS

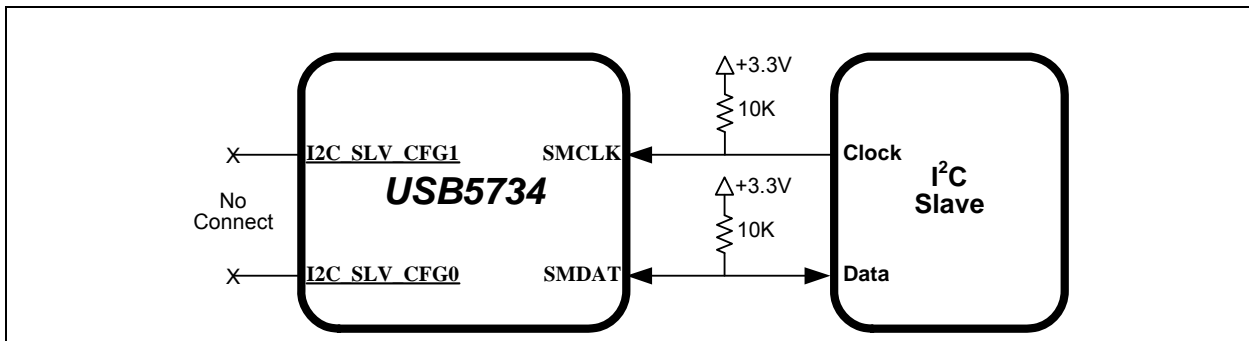

## 4.5 UART Bridge Connections

Figure 4-5 illustrates the device UART bridge connections. Refer to [Section 7.4, "Two Pin Serial Port \(UART\) Interface,"](#) on page 35 for additional information on this device interface.

FIGURE 4-5: UART BRIDGE CONNECTIONS

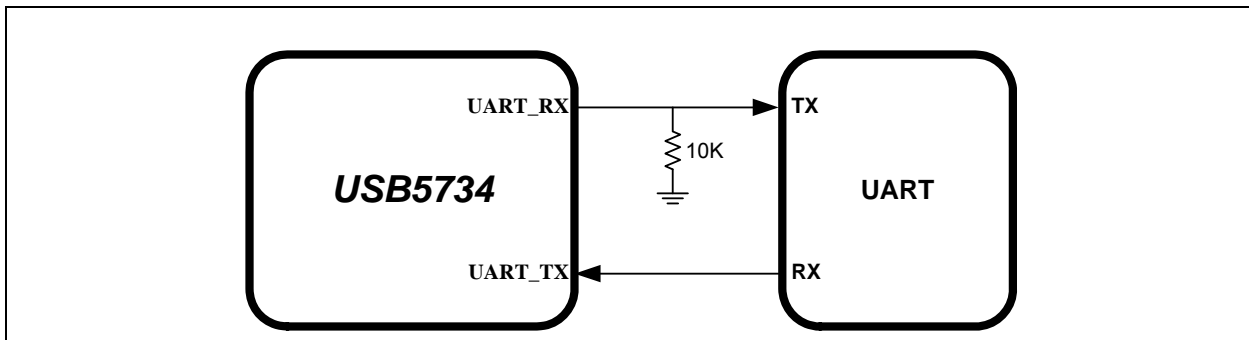

## 5.0 MODES OF OPERATION

The device provides two main modes of operation: Standby Mode and Hub Mode. These modes are controlled via the **RESET\_N** pin, as shown in [Table 5-1](#).

**TABLE 5-1: MODES OF OPERATION**

RESET_N Input	Summary
0	<b>Standby Mode:</b> This is the lowest power mode of the device. No functions are active other than monitoring the <b>RESET_N</b> input. All port interfaces are high impedance and the PLL is halted. Refer to <a href="#">Section 8.3.2, "External Chip Reset (RESET_N)"</a> for additional information on <b>RESET_N</b> .
1	<b>Hub (Normal) Mode:</b> The device operates as a configurable USB hub with battery charger detection. This mode has various sub-modes of operation, as detailed in <a href="#">Figure 5-1</a> . Power consumption is based on the number of active ports, their speed, and amount of data received.

The flowchart in [Figure 5-1](#) details the modes of operation and details how the device traverses through the Hub Mode stages (shown in bold). The remaining sub-sections provide more detail on each stage of operation.

**FIGURE 5-1: HUB MODE FLOWCHART**

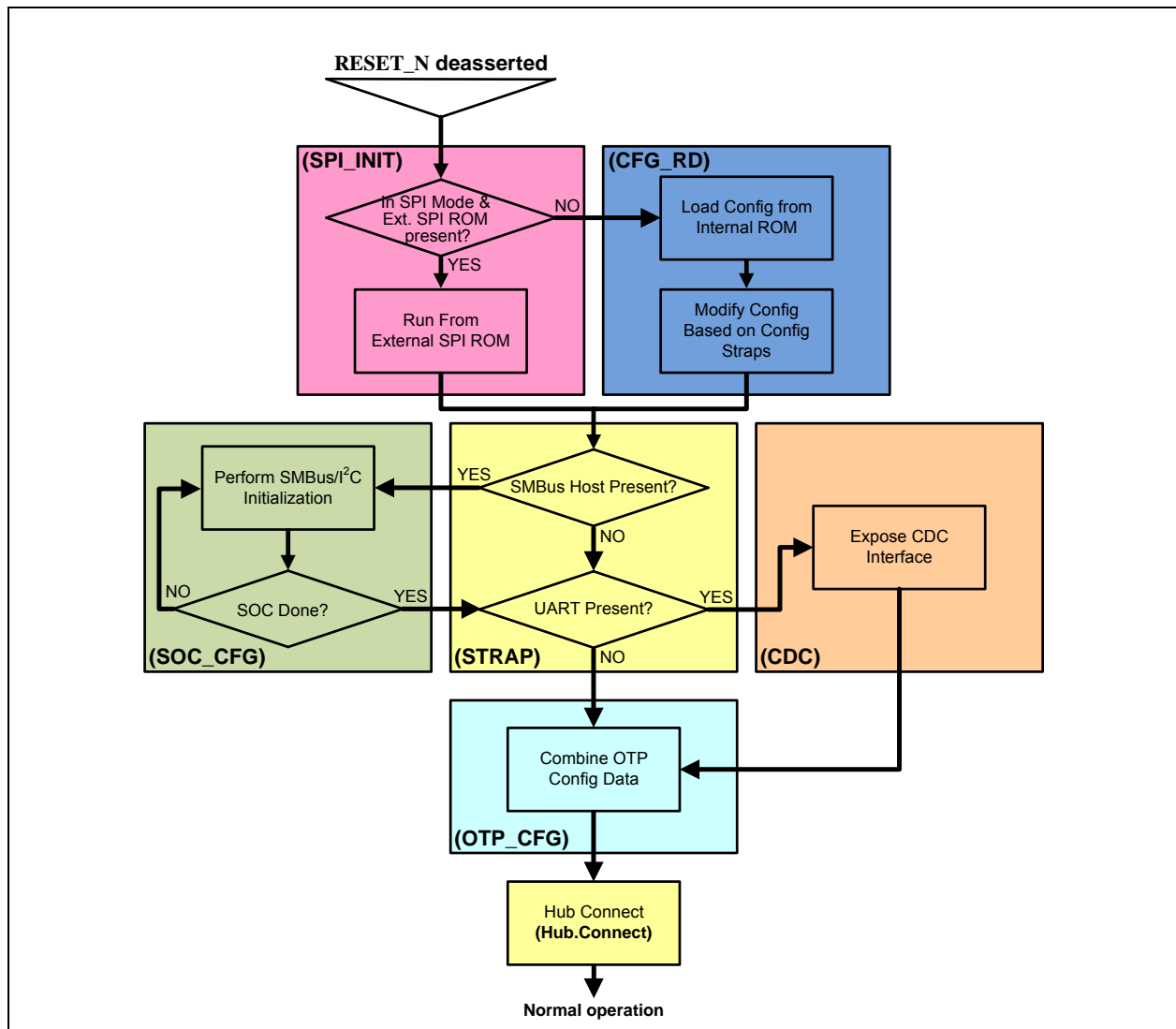

# USB5734

---

---

## 5.1 Boot Sequence

### 5.1.1 STANDBY MODE

If the **RESET\_N** pin is asserted, the hub will be in Standby Mode. This mode provides a very low power state for maximum power efficiency when no signaling is required. This is the lowest power state. In Standby Mode all downstream ports are disabled, the USB data pins are held in a high-impedance state, all transactions immediately terminate (no states saved), all internal registers return to their default state, the PLL is halted, and core logic is powered down in order to minimize power consumption. Because core logic is powered off, no configuration settings are retained in this mode and must be re-initialized after **RESET\_N** is negated high.

### 5.1.2 SPI INITIALIZATION STAGE (SPI\_INIT)

The first stage, the initialization stage, occurs on the deassertion of **RESET\_N**. In this stage, the internal logic is reset, the PLL locks if a valid clock is supplied, and the configuration registers are initialized to their default state. The internal firmware then checks for an external SPI ROM. The firmware looks for an external SPI flash device that contains a valid signature of "2DFU" (device firmware upgrade) beginning at address 0xFFFFA. If a valid signature is found, then the external ROM is enabled and the code execution begins at address 0x0000 in the external SPI device. If a valid signature is not found, then execution continues from internal ROM (CFG\_RD stage).

When using an external SPI ROM, a 1 Mbit, 60 MHz or faster ROM must be used. Both 1- and 2-bit SPI operation are supported. For optimum throughput, a 2-bit SPI ROM is recommended. Both mode 0 and mode 3 SPI ROMs are also supported.

If the system is not strapped for SPI Mode, code execution will continue from internal ROM (CFG\_RD stage).

### 5.1.3 CONFIGURATION READ STAGE (CFG\_RD)

In this stage, the internal firmware loads the default values from the internal ROM and then uses the configuration strapping options to override the default values. Refer to [Section 3.4, "Configuration Straps and Programmable Functions"](#) for information on usage of the various device configuration straps.

### 5.1.4 STRAP READ STAGE (STRAP)

In this stage, the firmware registers the configuration strap settings on the **SPI\_DO** and **SPI\_CLK** pins. Refer to [Section 3.4.1, "SPI/SMBus/I2C/UART Configuration \(I2C\\_SLV\\_CFG\[1:0\]\)"](#) for information on configuring these straps. If configured for SMBus Slave Mode, the next state will be SOC\_CFG. If configured for UART Mode, the device will become a UART bridging combination device and the next state will be CDC. If neither condition is met, the next state is OTP\_CFG.

### 5.1.5 SOC CONFIGURATION STAGE (SOC\_CFG)

In this stage, the SOC can modify any of the default configuration settings specified in the integrated ROM, such as USB device descriptors and port electrical settings.

There is no time limit on this mode. In this stage the firmware will wait indefinitely for the SMBus/I<sup>2</sup>C configuration. When the SOC has completed configuring the device, it must write to register 0xFF to end the configuration.

### 5.1.6 CDC CONFIGURATION STAGE (CDC)

If the device is configured in UART Mode, (UART Bridge), the hub feature controller will identify itself as a CDC UART device and move to the OTP\_CFG. Refer to [Section 3.4.1, "SPI/SMBus/I2C/UART Configuration \(I2C\\_SLV\\_CFG\[1:0\]\)"](#) for information on configuring the UART Mode.

### 5.1.7 OTP CONFIGURATION STAGE (OTP\_CFG)

Once the SOC has indicated that it is done with configuration, all configuration data is combined in this stage. The default data, the SOC configuration data, and the OTP data are all combined in the firmware and the device is programmed.

After the device is fully configured, it will go idle and then into suspend if there is no VBUS or Hub.Connect present. Once VBUS is present, and battery charging is enabled, the device will transition to the Battery Charger Detection Stage. If VBUS is present, and battery charging is not enabled, the device will transition to the Connect stage.

## 5.1.8 HUB CONNECT STAGE (HUB.CONNECT)

Once the CHGDET stage is completed, the device enters the Hub Connect stage. USB connect can be initiated by asserting the VBUS pin function high. The device will remain in the Hub Connect stage indefinitely until the VBUS pin function is deasserted.

## 5.1.9 NORMAL MODE

Lastly, the hub enters Normal Mode of operation. In this stage full USB operation is supported under control of the USB Host on the upstream port. The device will remain in the normal mode until the operating mode is changed by the system.

If **RESET\_N** is asserted low, then Standby Mode is entered. The device may then be placed into any of the designated hub stages. Asserting a soft disconnect on the upstream port will cause the hub to return to the Hub.Connect stage until the soft disconnect is negated.

# USB5734

---

---

## 6.0 DEVICE CONFIGURATION

The device supports a large number of features (some mutually exclusive), and must be configured in order to correctly function when attached to a USB host controller. The hub can be configured either internally or externally depending on the implemented interface.

Microchip provides a comprehensive software programming tool, Pro-Touch, for configuring the USB5734 functions, registers and OTP memory. All configuration is to be performed via the Pro-Touch programming tool. For additional information on the Pro-Touch programming tool, refer to the Software Libraries within the Microchip USB5734 product page at [www.microchip.com/USB5734](http://www.microchip.com/USB5734).

**Note:** Device configuration straps and programmable pins are detailed in [Section 3.4, "Configuration Straps and Programmable Functions," on page 17](#). Refer to [Section 7.0, "Device Interfaces"](#) for detailed information on each device interface.

## 6.1 Customer Accessible Functions

The following USB or SMBus accessible functions are available to the customer via the Pro-Touch Programming Tool.

**Note:** For additional programming details, refer to the Pro-Touch programming tool.

### 6.1.1 USB ACCESSIBLE FUNCTIONS

#### 6.1.1.1 I<sup>2</sup>C Bridging Access over USB

Access to I<sup>2</sup>C devices is performed as a pass-through operation from the USB Host. The device firmware has no knowledge of the operation of the attached I<sup>2</sup>C device. For more information, refer to the Microchip USB5734 product page and SDK at [www.microchip.com/USB5734](http://www.microchip.com/USB5734).

**Note:** Refer to [Section 7.3, "I<sup>2</sup>C Bridge Interface," on page 34](#) for additional information on the I<sup>2</sup>C interface.

#### 6.1.1.2 SPI Access over USB

Access to an attached SPI device is performed as a pass-through operation from the USB Host. The device firmware has no knowledge of the operation of the attached SPI device. For more information, refer to the Microchip USB5734 product page and SDK at [www.microchip.com/USB5734](http://www.microchip.com/USB5734).

**Note:** Refer to [Section 7.1, "SPI Master Interface," on page 34](#) for additional information on the SPI.

#### 6.1.1.3 UART Access over USB

Access to UART devices is performed as a pass-through operation from the USB Host. The device firmware has no knowledge of the operation of the attached UART device. For more information, refer to the Microchip USB5734 product page and SDK at [www.microchip.com/USB5734](http://www.microchip.com/USB5734).

**Note:** Refer to [Section 7.4, "Two Pin Serial Port \(UART\) Interface," on page 35](#) for additional information on the UART interface.

#### 6.1.1.4 OTP Access over USB

The OTP ROM in the device is accessible via the USB bus. All OTP parameters can be modified to the USB Host. The OTP operates in Single Ended mode. For more information, refer to the Microchip USB5734 product page and SDK at [www.microchip.com/USB5734](http://www.microchip.com/USB5734).

#### 6.1.1.5 Battery Charging Access over USB

The Battery charging behavior of the device can be dynamically changed by the USB Host when something other than the preprogrammed or OTP programmed behavior is desired. For more information, refer to the Microchip USB5734 product page and SDK at [www.microchip.com/USB5734](http://www.microchip.com/USB5734).



## 6.1.2 SMBUS ACCESSIBLE FUNCTIONS

OTP access and configuration of specific device functions are possible via the USB5734 SMBus. All OTP parameters can be modified via the SMBus Host. The OTP can be programmed to operate in Single-Ended, Differential, Redundant, or Differential Redundant mode, depending on the level of reliability required. For more information, refer to AN1903 - "Configuration Options for the USB5734 and USB5744" application note at [www.microchip.com/AN1903](http://www.microchip.com/AN1903).

# USB5734

---

## 7.0 DEVICE INTERFACES

The USB5734 provides multiple interfaces for configuration and external memory access. This section details the various device interfaces and their usage:

- [SPI Master Interface](#)
- [SMBus Slave Interface](#)
- [I2C Bridge Interface](#)
- [Two Pin Serial Port \(UART\) Interface](#)

**Note:** For details on how to enable each interface, refer to [Section 3.4.1, "SPI/SMBus/I2C/UART Configuration \(I2C\\_SLV\\_CFG\[1:0\]\)"](#).

For information on device connections, refer to [Section 4.0, "Device Connections"](#). For information on device configuration, refer to [Section 6.0, "Device Configuration"](#).

Microchip provides a comprehensive software programming tool, Pro-Touch, for configuring the USB5734 functions, registers and OTP memory. All configuration is to be performed via the Pro-Touch programming tool. For additional information on the Pro-Touch programming tool, refer to Software Libraries within Microchip USB5734 product page at [www.microchip.com/USB5734](http://www.microchip.com/USB5734).

### 7.1 SPI Master Interface

The device is capable of code execution from an external SPI ROM. When configured for SPI Mode, on power up the firmware looks for an external SPI flash device that contains a valid signature of 2DFU (device firmware upgrade) beginning at address 0xFFFA. If a valid signature is found, then the external ROM is enabled and the code execution begins at address 0x0000 in the external SPI device. If a valid signature is not found, then execution continues from internal ROM.

**Note:** For SPI timing information, refer to [Section 9.6.7, "SPI Timing"](#).

### 7.2 SMBus Slave Interface

The device includes an integrated SMBus slave interface, which can be used to access internal device run time registers or program the internal OTP memory. SMBus slave detection is accomplished by detection of pull-up resistors on both the SMDAT and SMCLK signals. Refer to [Section 3.4.1, "SPI/SMBus/I2C/UART Configuration \(I2C\\_SLV\\_CFG\[1:0\]\)"](#) for additional information.

**Note:** All device configuration must be performed via the Pro-Touch Programming Tool. For additional information on the Pro-Touch programming tool, refer to Software Libraries within Microchip USB5734 product page at [www.microchip.com/USB5734](http://www.microchip.com/USB5734).

### 7.3 I<sup>2</sup>C Bridge Interface

The I<sup>2</sup>C Bridge interface implements a subset of the I<sup>2</sup>C Master Specification (Please refer to the *Philips Semiconductor Standard I<sup>2</sup>C-Bus Specification* for details on I<sup>2</sup>C bus protocols). The I<sup>2</sup>C Bridge conforms to the Fast-Mode I<sup>2</sup>C Specification (400 kbit/s transfer rate and 7-bit addressing) for protocol and electrical compatibility. The device acts as the master and generates the serial clock SCL, controls the bus access (determines which device acts as the transmitter and which device acts as the receiver), and generates the START and STOP conditions. The I<sup>2</sup>C Bridge interface frequency is configurable through the I<sup>2</sup>C Bridging commands. I<sup>2</sup>C Bridge frequencies are derived from the formula 626KHz/n, where n is any integer from 1 to 256. Refer to [Section 3.4.1, "SPI/SMBus/I2C/UART Configuration \(I2C\\_SLV\\_CFG\[1:0\]\)"](#) for additional information.

**Note:** Extensions to the I<sup>2</sup>C Specification are not supported.

All device configuration must be performed via the Pro-Touch Programming Tool. For additional information on the Pro-Touch programming tool, contact your local sales representative.

## 7.4 Two Pin Serial Port (UART) Interface

The device incorporates a fully programmable, universal asynchronous receiver/transmitter (UART) that is functionally compatible with the NS 16550AF, 16450, 16450 ACE registers and the 16C550A. The UART performs serial-to-parallel conversion on received characters and parallel-to-serial conversion on transmit characters. Two sets of baud rates are provided: 24 Mhz and 16 MHz. When the 24 Mhz source clock is selected, standard baud rates from 50 to 115.2 K are available. When the source clock is 16 MHz, baud rates from 125 K to 1,000 K are available. The character options are programmable for the transmission of data in word lengths of from five to eight, 1 start bit; 1, 1.5 or 2 stop bits; even, odd, sticky or no parity; and prioritized interrupts. The UART contains a programmable baud rate generator that is capable of dividing the input clock or crystal by a number from 1 to 65535. The UART is also capable of supporting the MIDI data rate.

### 7.4.1 TRANSMIT OPERATION

Transmission is initiated by writing the data to be sent to the TX Holding Register or TX FIFO (if enabled). The data is then transferred to the TX Shift Register together with a start bit and parity and stop bits as determined by settings in the Line Control Register. The bits to be transmitted are then shifted out of the TX Shift Register in the order Start bit, Data bits (LSB first), Parity bit, Stop bit, using the output from the Baud Rate Generator (divided by 16) as the clock.

If enabled, a TX Holding Register Empty interrupt will be generated when the TX Holding Register or the TX FIFO (if enabled) becomes empty.

When FIFOs are enabled (i.e. bit 0 of the FIFO Control Register is set), the UART can store up to 16 bytes of data for transmission at a time. Transmission will continue until the TX FIFO is empty. The FIFO's readiness to accept more data is indicated by interrupt.

### 7.4.2 RECEIVE OPERATION

Data is sampled into the RX Shift Register using the Receive clock, divided by 16. The Receive clock is provided by the Baud Rate Generator. A filter is used to remove spurious inputs that last for less than two periods of the Receive clock. When the complete word has been clocked into the receiver, the data bits are transferred to the RX Buffer Register or to the RX FIFO (if enabled) to be read by the CPU. (The first bit of the data to be received is placed in bit 0 of this register.) The receiver also checks that the parity bit and stop bits are as specified by the Line Control Register.

If enabled, an RX Data Received interrupt will be generated when the data has been transferred to the RX Buffer Register or, if FIFOs are enabled, when the RX Trigger Level has been reached. Interrupts can also be generated to signal RX FIFO Character Timeout, incorrect parity, a missing stop bit (frame error) or other Line Status errors.

When FIFOs are enabled (i.e. bit 0 of the FIFO Control Register is set), the UART can store up to 16 bytes of received data at a time. Depending on the selected RX Trigger Level, interrupt will go active to indicate that data is available when the RX FIFO contains 1, 4, 8 or 14 bytes of data.

# USB5734

## 8.0 FUNCTIONAL DESCRIPTIONS

This section details various USB5734 functions, including:

- [Downstream Battery Charging](#)
- [FlexConnect](#)
- [Resets](#)
- [Link Power Management \(LPM\)](#)
- [Remote Wakeup Indicator](#)
- [Port Control Interface](#)

### 8.1 Downstream Battery Charging

The device can be configured by an OEM to have any of the downstream ports support battery charging. The hub's role in battery charging is to provide acknowledgment to a device's query as to whether the hub system supports USB battery charging. The hub silicon does not provide any current or power FETs or any additional circuitry to actually charge the device. Those components must be provided externally by the OEM.

**FIGURE 8-1: BATTERY CHARGING EXTERNAL POWER SUPPLY**

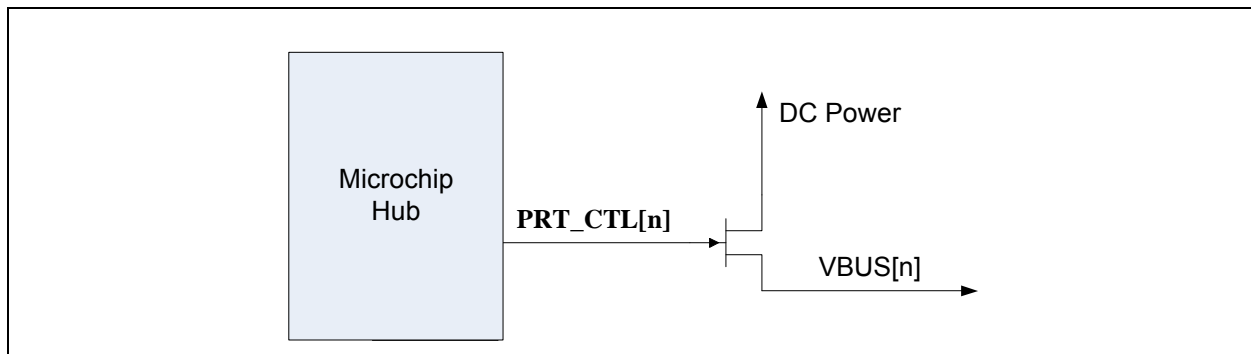

If the OEM provides an external supply capable of supplying current per the battery charging specification, the hub can be configured to indicate the presence of such a supply from the device. This indication, via the **PRT\_CTL[4:1]** pins, is on a per port basis. For example, the OEM can configure two ports to support battery charging through high current power FETs and leave the other two ports as standard USB ports.

For additional information, refer to the Microchip USB5734 Battery Charging application note on the Microchip.com USB5734 product page at [www.microchip.com/USB5734](http://www.microchip.com/USB5734).

### 8.2 FlexConnect

This feature allows the upstream port to be swapped with downstream physical port 1. Only downstream port 1 can be swapped physically. Using port remapping, any logical port (number assignment) can be swapped with the upstream port (non-physical).

FlexConnect is enabled/disabled via the FLEXCONNECT control bit in the Connect Configuration register (address 0x318E). The FLEXCONNECT configuration bit switches the port. This bit can be controlled via the I<sup>2</sup>C interface or via the FLEXCMD pin (**PROG\_FUNC6** in configurations 1 or 2). Toggling of FLEXCMD will cause an interrupt to the device firmware. The firmware will then change the port direction based on the input value. Refer to [Section 3.4.5, "Device Mode / PROG\\_FUNC\[7:1\] Configuration \(CFG\\_STRAP\)"](#) for additional information.

For additional information, refer to the Microchip USB5734 FlexConnect application note on the Microchip.com USB5734 product page.

## 8.3 Resets

The device includes the following chip-level reset sources:

- [Power-On Reset \(POR\)](#)
- [External Chip Reset \(RESET\\_N\)](#)
- [USB Bus Reset](#)

### 8.3.1 POWER-ON RESET (POR)

A power-on reset occurs whenever power is initially supplied to the device, or if power is removed and reapplied to the device. A timer within the device will assert the internal reset per the specifications listed in [Section 9.6.2, "Power-On and Configuration Strap Timing," on page 46](#).

### 8.3.2 EXTERNAL CHIP RESET (RESET\_N)

A valid hardware reset is defined as assertion of **RESET\_N**, after all power supplies are within operating range, per the specifications in [Section 9.6.3, "Reset and Configuration Strap Timing," on page 47](#). While reset is asserted, the device (and its associated external circuitry) enters Standby Mode and consumes minimal current.

Assertion of **RESET\_N** causes the following:

1. The PHY is disabled and the differential pairs will be in a high-impedance state.
2. All transactions immediately terminate; no states are saved.
3. All internal registers return to the default state.
4. The external crystal oscillator is halted.
5. The PLL is halted.

**Note:** All power supplies must have reached the operating levels mandated in [Section 9.2, "Operating Conditions\\*\\*," on page 42](#), prior to (or coincident with) the assertion of **RESET\_N**.

### 8.3.3 USB BUS RESET

In response to the upstream port signaling a reset to the device, the device performs the following:

**Note:** The device does not propagate the upstream USB reset to downstream devices.

1. Sets default address to 0.
2. Sets configuration to Unconfigured.
3. Moves device from suspended to active (if suspended).
4. Complies with the USB Specification for behavior after completion of a reset sequence.

The host then configures the device in accordance with the USB Specification.

## 8.4 Link Power Management (LPM)

The device supports the L0 (On), L1 (Sleep), and L2 (Suspend) link power management states. These supported LPM states offer low transitional latencies in the tens of microseconds versus the much longer latencies of the traditional USB suspend/resume in the tens of milliseconds. The supported LPM states are detailed in [Table 8-1](#).

**TABLE 8-1: LPM STATE DEFINITIONS**

State	Description	Entry/Exit Time to L0
L2	Suspend	Entry: ~3 ms Exit: ~2 ms (from start of RESUME)
L1	Sleep	Entry: <10 us Exit: <50 us
L0	Fully Enabled (On)	-

# USB5734

## 8.5 Remote Wakeup Indicator

The remote wakeup indicator feature uses USB2\_SUSP\_IND as a side band signal to wake up the host when in USB2.0 suspend. This feature is enabled and disabled via the HUB\_RESUME\_INHIBIT configuration bit in the hub configuration space register CFG3. The only way to control the bit is by configuration EEPROM, SMBus or internal ROM default setting. The state is only modified during a power on reset, or hardware reset. No dynamic reconfiguring of this capability is possible.

When HUB\_RESUME\_INHIBIT = '0', Normal Resume Behavior per the USB 2.0 specification

When HUB\_RESUME\_INHIBIT = '1', Modified Resume Behavior is enabled

**Note:** The USB2\_SUSP\_IND signal only indicates the USB2.0 state.

For additional information, refer to the Microchip USB5734 Suspend Indicator application note on the Microchip.com USB5734 product page.

## 8.6 Port Control Interface

Port power and over-current sense share the same pin (**PRT\_CTLx**) for each port. These functions can be controlled directly from the USB hub, or via the processor. Additionally, smart port controllers can be controlled via the I<sup>2</sup>C interface.

The device can be configured into the following port control modes:

- Ganged Mode
- Combined Mode

Port connection in various modes are detailed in the following subsections.

### 8.6.1 PORT CONNECTION IN GANGED MODE

In this mode, one pin (**GANG\_PWR**) is used to control port power and over-current sensing.

### 8.6.2 PORT CONNECTION IN COMBINED MODE

#### 8.6.2.1 Port Power Control using USB Power Switch

When operating in combined mode, the device will have one port power control and over-current sense pin for each downstream port. When disabling port power, the driver will actively drive a '0'. To avoid unnecessary power dissipation, the pull-up resistor will be disabled at that time. When port power is enabled, it will disable the output driver and enable the pull-up resistor, making it an open drain output. If there is an over-current situation, the USB Power Switch will assert the open drain OCS signal. The Schmidt trigger input will recognize that as a low. The open drain output does not interfere. The over-current sense filter handles the transient conditions such as low voltage while the device is powering up.

**FIGURE 8-2: PORT POWER CONTROL WITH USB POWER SWITCH**

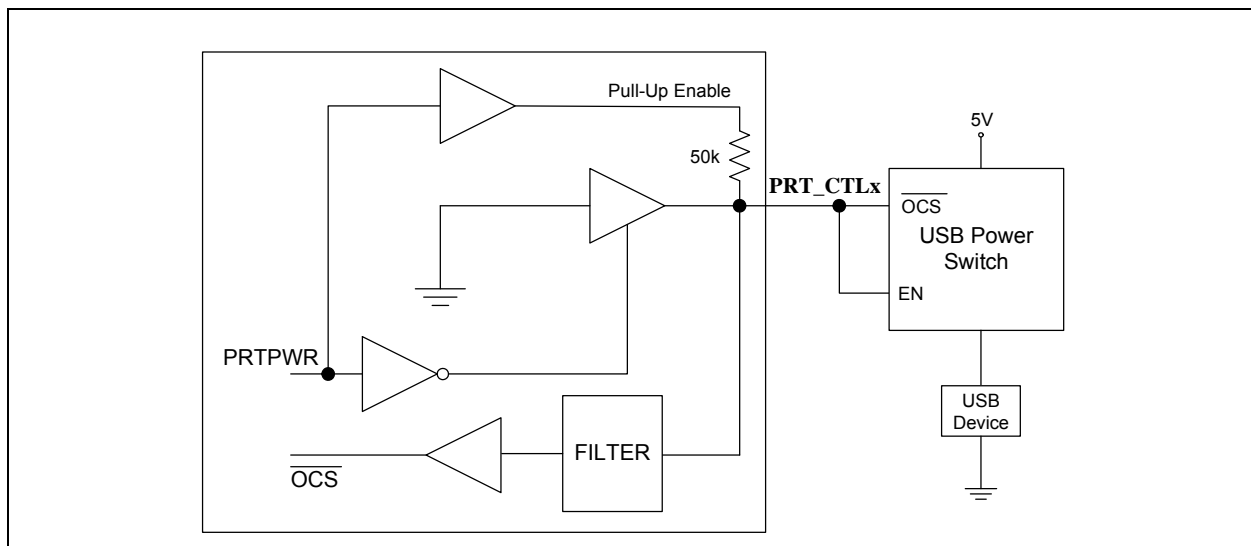

When the port is enabled, the **PRT\_CTLx** pin input is constantly sampled. Overcurrent events can be detected in one of two ways:

- Single, continuous low pulse (consecutive low samples over  $t_{ocs\_single}$ ), as shown in [Figure 8-3](#).
- Two short low pulses within a rolling window (two groupings of 1 or more low samples over  $t_{ocs\_double}$ ), as shown in [Figure 8-4](#).

**FIGURE 8-3: SINGLE LOW PULSE OVERCURRENT DETECTION**

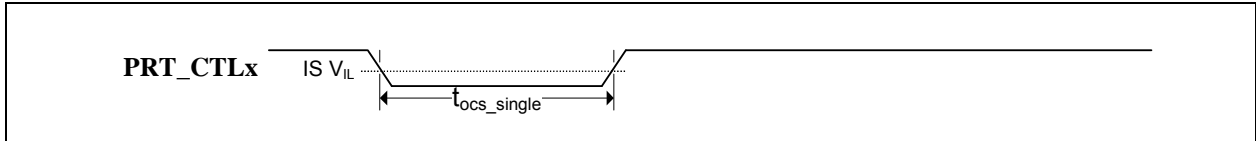

**FIGURE 8-4: DOUBLE LOW PULSE OVERCURRENT DETECTION**

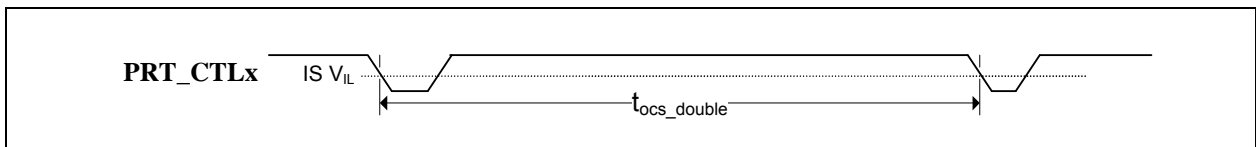

**TABLE 8-2: OVERCURRENT PULSE TIMING**

Symbol	Description	Min	Max	Units
$t_{ocs\_single}$	single low pulse assertion time	5	-	ms
$t_{ocs\_double}$	double low pulse window	-	20	ms

### 8.6.2.2 Port Power Control using Poly Fuse

When using the device with a poly fuse, there is no need for an output power control. To maintain consistency, the same circuit will be used. A single port power control and over-current sense for each downstream port is still used from the Hub's perspective. When disabling port power, the driver will actively drive a '0'. This will have no effect as the external diode will isolate pin from the load. When port power is enabled, it will disable the output driver and enable the pull-up resistor. This means that the pull-up resistor is providing 3.3 volts to the anode of the diode. If there is an over-current situation, the poly fuse will open. This will cause the cathode of the diode to go to 0 volts. The anode of the diode will be at 0.7 volts, and the Schmidt trigger input will register this as a low resulting in an over-current detection. The open drain output does not interfere.

**Note:** The USB 2.0 and USB 3.1 Gen 1 bPwrOn2PwrGood descriptors must be set to 0 when using poly-fuse mode. Refer to Microchip application note AN1903 "Configuration Options for the USB5734 and USB5744" for details on how to change these values.

**FIGURE 8-5: PORT POWER CONTROL USING A POLY FUSE**

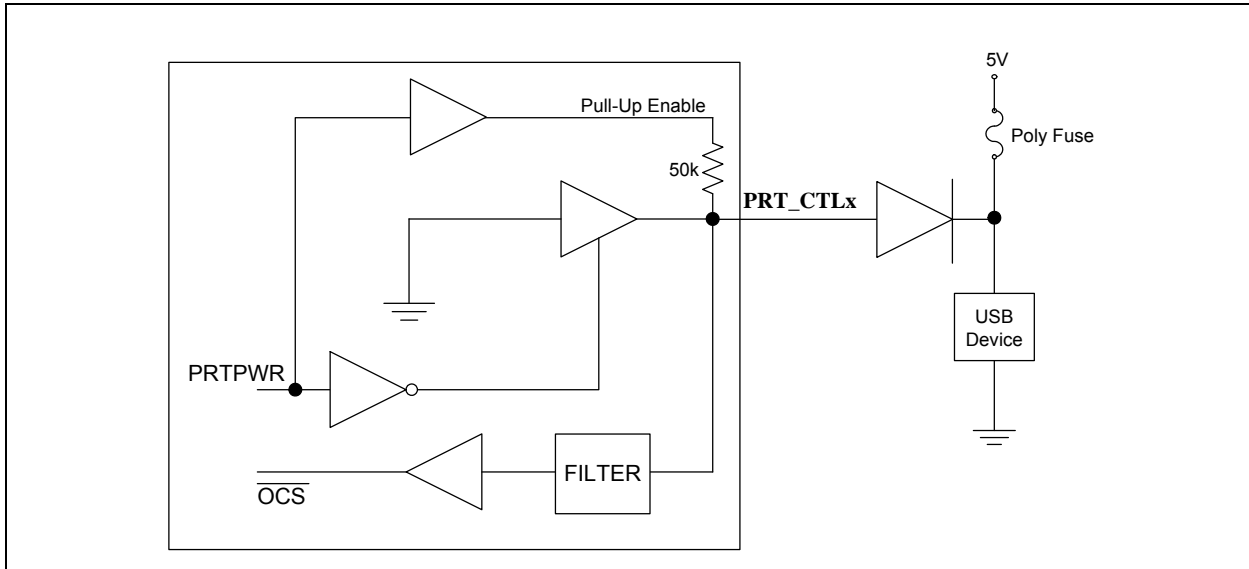

### 8.6.2.3 Port Power Control with Single Poly Fuse and Multiple Loads

Many customers use a single poly fuse to power all their devices. For the ganged situation, all power control pins must be tied together.

**FIGURE 8-6: PORT POWER CONTROL WITH GANGED CONTROL WITH POLY FUSE**

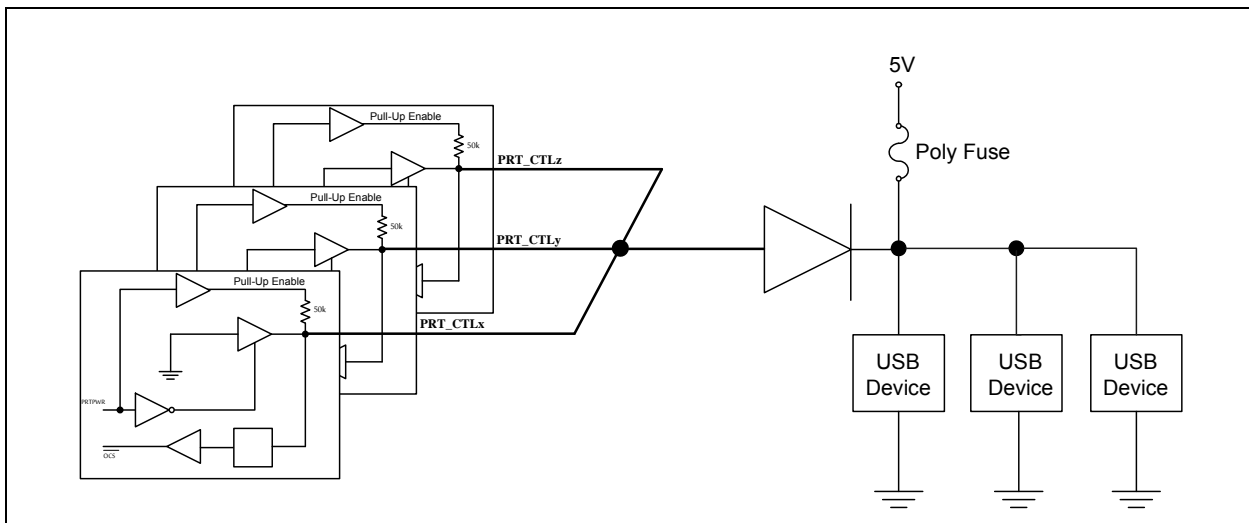



## 8.6.3 PORT CONTROLLER CONNECTION EXAMPLE

**FIGURE 8-7: USB5734 WITH 4 GENERIC PORT POWER CONTROLLERS (2 BC ENABLED)**

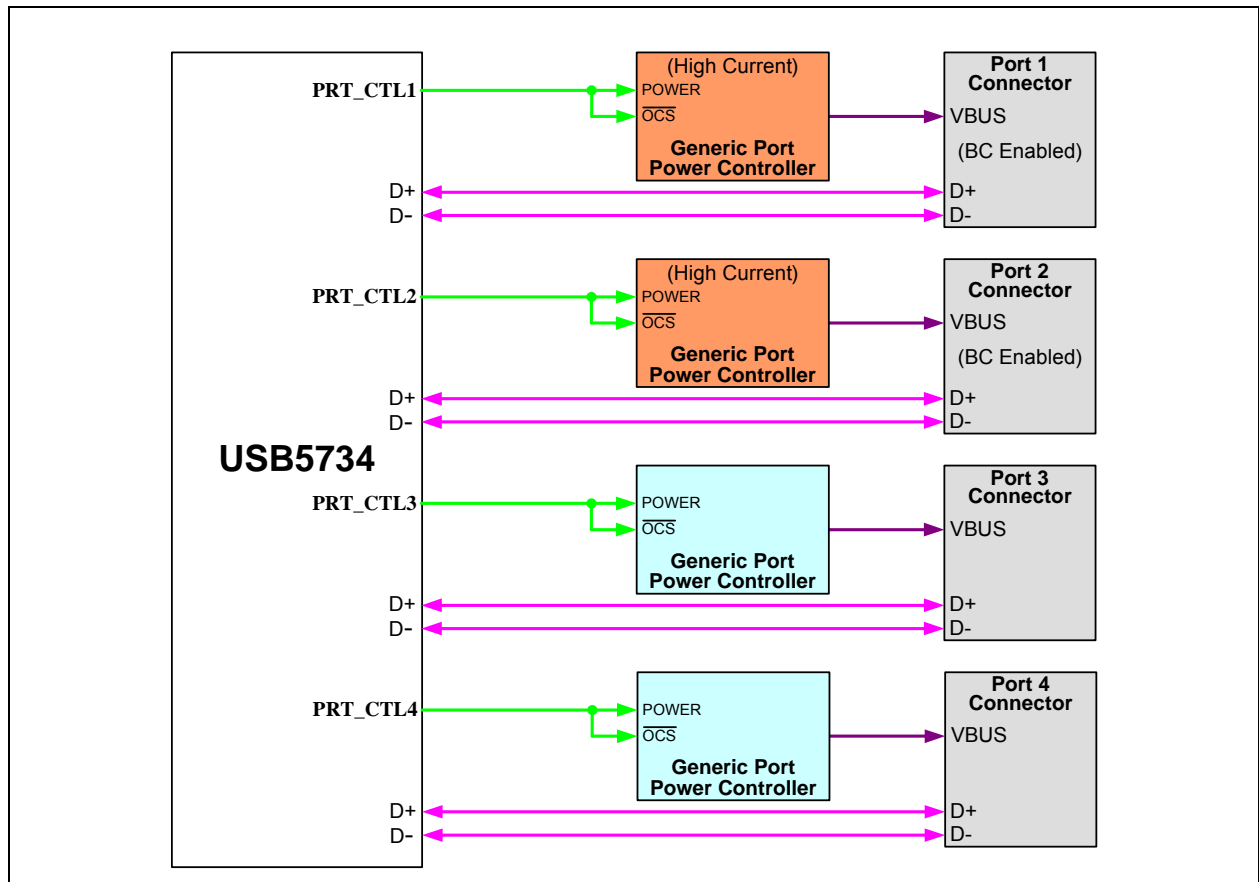

**Note:** The CFG\_BC\_EN configuration strap must be properly configured to enable battery charging on the appropriate ports. For example, in the application shown in [Figure 8-7](#), CFG\_BC\_EN must be connected to an external 10 kΩ pull-down resistor to enable battery charging on Ports 1 and 2. For more information on the CFG\_BC\_EN configuration strap, refer to [Section 3.4.4, "Battery Charging Configuration \(CFG\\_BC\\_EN\)"](#).

# USB5734

## 9.0 OPERATIONAL CHARACTERISTICS

### 9.1 Absolute Maximum Ratings\*

+1.2 V Supply Voltage (VDD12) (Note 1)	-0.5 V to +1.32 V
+3.3 V Supply Voltage (VDD33) (Note 1)	-0.5 V to +4.6 V
Positive voltage on input signal pins, with respect to ground (Note 2)	+4.6 V
Negative voltage on input signal pins, with respect to ground	-0.5 V
Positive voltage on XTALI/CLK_IN, with respect to ground	+3.63 V
Positive voltage on USB DP/DM signal pins, with respect to ground	+6.0 V
Positive voltage on USB 3.1 Gen 1 USB3UP_XXXX and USB3DN_XXXX signal pins, with respect to ground	1.32 V
Storage Temperature	-55°C to +150°C
Junction Temperature	+125°C
Lead Temperature Range	Refer to JEDEC Spec. J-STD-020
HBM ESD Performance	3 kV

**Note 1:** When powering this device from laboratory or system power supplies, it is important that the absolute maximum ratings not be exceeded or device failure can result. Some power supplies exhibit voltage spikes on their outputs when AC power is switched on or off. In addition, voltage transients on the AC power line may appear on the DC output. If this possibility exists, it is suggested to use a clamp circuit.

**Note 2:** This rating does not apply to the following pins: All USB DM/DP pins, XTALI/CLK\_IN, and XTALO

\*Stresses exceeding those listed in this section could cause permanent damage to the device. This is a stress rating only. Exposure to absolute maximum rating conditions for extended periods may affect device reliability. Functional operation of the device at any condition exceeding those indicated in [Section 9.2, "Operating Conditions\\*\\*"](#), [Section 9.5, "DC Specifications"](#), or any other applicable section of this specification is not implied.

### 9.2 Operating Conditions\*\*

+1.2 V Supply Voltage (VDD12)	+1.08 V to +1.32 V
+3.3 V Supply Voltage (VDD33)	+3.0 V to +3.6 V
Input Signal Pins Voltage (Note 2)	-0.3 V to +3.6 V
XTALI/CLK_IN Voltage	-0.3 V to +3.6 V
USB 2.0 DP/DM Signal Pins Voltage	-0.3 V to +5.5 V
USB 3.1 Gen 1 USB3UP_XXXX and USB3DN_XXXX Signal Pins Voltage	-0.3 V to +1.32 V
Ambient Operating Temperature in Still Air (T <sub>A</sub> )	<a href="#">Note 3</a>
+1.2 V Supply Voltage Rise Time (T <sub>RT</sub> in <a href="#">Figure 9-1</a> )	400 μs
+3.3 V Supply Voltage Rise Time (T <sub>RT</sub> in <a href="#">Figure 9-1</a> )	400 μs

**Note 3:** 0°C to +70°C for commercial version, -40°C to +85°C for industrial version.

\*\*Proper operation of the device is guaranteed only within the ranges specified in this section.

**Note:** Do not drive input signals without power supplied to the device.

**FIGURE 9-1: SUPPLY RISE TIME MODEL**

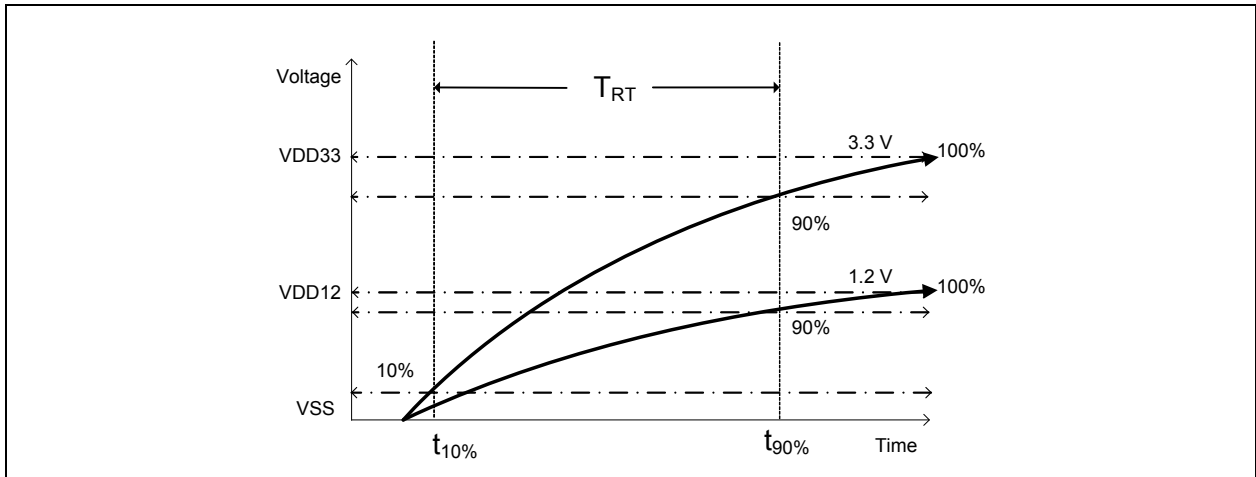

### 9.3 Package Thermal Specifications

**TABLE 9-1: PACKAGE THERMAL PARAMETERS**

Symbol	°C/W	Velocity (Meters/s)
$\Theta_{JA}$	25	0
	22	1
$\Psi_{JT}$	0.2	0
	0.3	1
$\Theta_{JC}$	2.5	0
	2.5	1

**Note:** Thermal parameters are measured or estimated for devices in a multi-layer 2S2P PCB per JESDN51.

**TABLE 9-2: MAXIMUM POWER DISSIPATION**

Parameter	Value	Units
PD(max)	1400	mW

# USB5734

---

---

## 9.4 Power Consumption

This section details the power consumption of the device as measured during various modes of operation. Power dissipation is determined by temperature, supply voltage, and external source/sink requirements.

**TABLE 9-3: DEVICE POWER CONSUMPTION**

	Typical (mA)		Typical Power (mW)
	VDD33	VDD12	
Reset	0.8	1.8	4.8
No VBUS	2.0	5.0	12.6
Global Suspend	2.0	5.2	12.9
4 FS Ports	39	35	170
4 HS Ports	53	42	222
4 SS Ports	55	683	1001
4 SS/HS Ports	93	688	1132

## 9.5 DC Specifications

**TABLE 9-4: I/O DC ELECTRICAL CHARACTERISTICS**

Parameter	Symbol	Min	Typical	Max	Units	Notes
<b>I Type Input Buffer</b>						
Low Input Level	$V_{IL}$			0.9	V	
High Input Level	$V_{IH}$	2.1			V	
<b>IS Type Input Buffer</b>						
Low Input Level	$V_{IL}$			0.9	V	
High Input Level	$V_{IH}$	1.9			V	
Schmitt Trigger Hysteresis ( $V_{IHT} - V_{ILT}$ )	$V_{HYS}$	9	20	40	mV	Note 4
<b>O6 Type Output Buffer</b>						
Low Output Level	$V_{OL}$			0.4	V	$I_{OL} = 6 \text{ mA}$
High Output Level	$V_{OH}$	VDD33-0.4			V	$I_{OH} = -6 \text{ mA}$
<b>O10 Type Output Buffer</b>						
Low Output Level	$V_{OL}$			0.4	V	$I_{OL} = 10 \text{ mA}$
High Output Level	$V_{OH}$	VDD33-0.4			V	$I_{OH} = -10 \text{ mA}$
<b>O12 Type Output Buffer</b>						
Low Output Level	$V_{OL}$			0.4	V	$I_{OL} = 12 \text{ mA}$
High Output Level	$V_{OH}$	VDD33-0.4			V	$I_{OH} = -12 \text{ mA}$
<b>OD12 Type Output Buffer</b>						
Low Output Level	$V_{OL}$			0.4	V	$I_{OL} = 12 \text{ mA}$
<b>ICLK Type Input Buffer (XTALI Input)</b>						
Low Input Level	$V_{IL}$			0.50	V	Note 5
High Input Level	$V_{IH}$	0.85		VDD33	V	
<b>IO-U Type Buffer (See Note 6)</b>						
						Note 6

**Note 4:** The PROG\_FUNC3 pin has a Schmitt trigger hysteresis minimum of 10 mV and a maximum of 60 mV.

**Note 5:** XTALI can optionally be driven from a 25 MHz singled-ended clock oscillator.

**Note 6:** Refer to the USB 3.1 Gen 1 Specification for USB DC electrical characteristics.

# USB5734

## 9.6 AC Specifications

This section details the various AC timing specifications of the device.

### 9.6.1 POWER SUPPLY AND RESET\_N SEQUENCE TIMING

Figure 9-2 illustrates the recommended power supply sequencing and timing for the device. **VDD33** should rise after or at the same rate as **VDD12**. Similarly, **RESET\_N** and/or **VBUS\_DET** should rise after or at the same rate as **VDD33**. **VBUS\_DET** and **RESET\_N** do not have any other timing dependencies.

**FIGURE 9-2: POWER SUPPLY AND RESET\_N SEQUENCE TIMING**

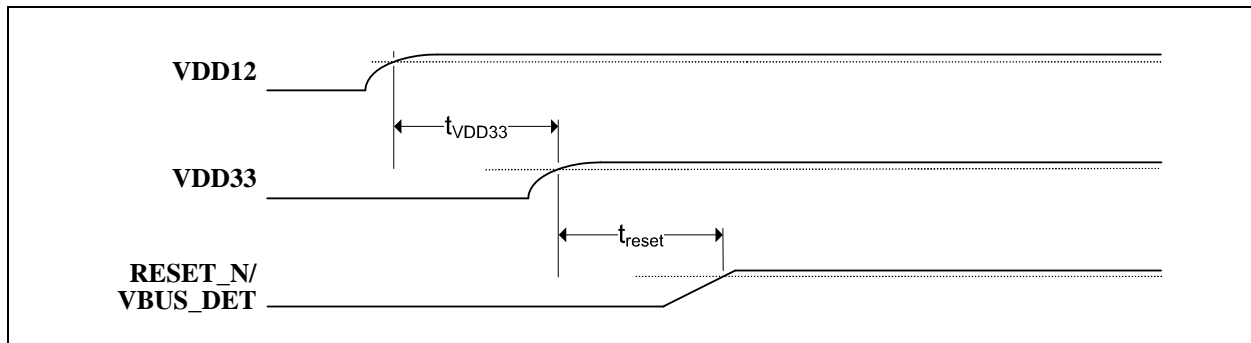

**TABLE 9-5: POWER SUPPLY AND RESET\_N SEQUENCE TIMING**

Symbol	Description	Min	Typ	Max	Units
t <sub>VDD33</sub>	VDD12 to VDD33 rise time	0			ms
t <sub>reset</sub>	VDD33 to RESET_N/VBUS_DET rise time	0			ms

### 9.6.2 POWER-ON AND CONFIGURATION STRAP TIMING

Figure 9-3 illustrates the configuration strap valid timing requirements in relation to power-on, for applications where **RESET\_N** is not used at power-on. In order for valid configuration strap values to be read at power-on, the following timing requirements must be met. The operational levels (V<sub>opp</sub>) for the external power supplies are detailed in Section 9.2, "Operating Conditions\*\*," on page 42.

**FIGURE 9-3: POWER-ON CONFIGURATION STRAP VALID TIMING**

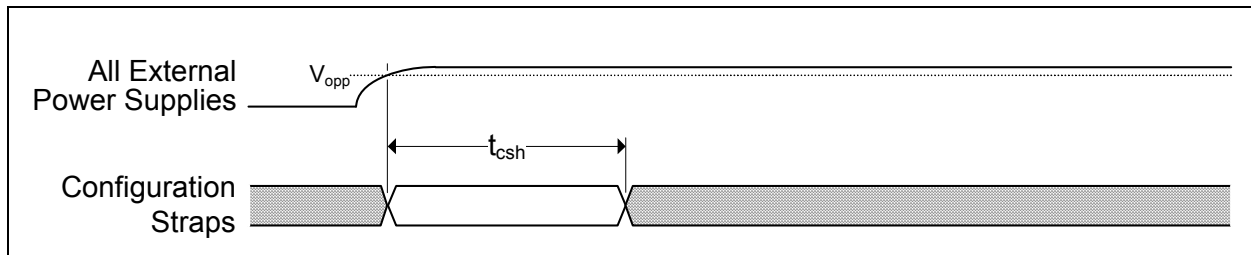

**TABLE 9-6: POWER-ON CONFIGURATION STRAP LATCHING TIMING**

Symbol	Description	Min	Typ	Max	Units
t <sub>csh</sub>	Configuration strap hold after external power supplies at operational levels	1			ms

Device configuration straps are also latched as a result of **RESET\_N** assertion. Refer to Section 9.6.3, "Reset and Configuration Strap Timing" for additional details.

## 9.6.3 RESET AND CONFIGURATION STRAP TIMING

Figure 9-4 illustrates the **RESET\_N** pin timing requirements and its relation to the configuration strap pins. Assertion of **RESET\_N** is not a requirement. However, if used, it must be asserted for the minimum period specified. Refer to Section 8.3, "Resets" for additional information on resets. Refer to Section 3.4, "Configuration Straps and Programmable Functions" for additional information on configuration straps.

**FIGURE 9-4: RESET\_N CONFIGURATION STRAP TIMING**

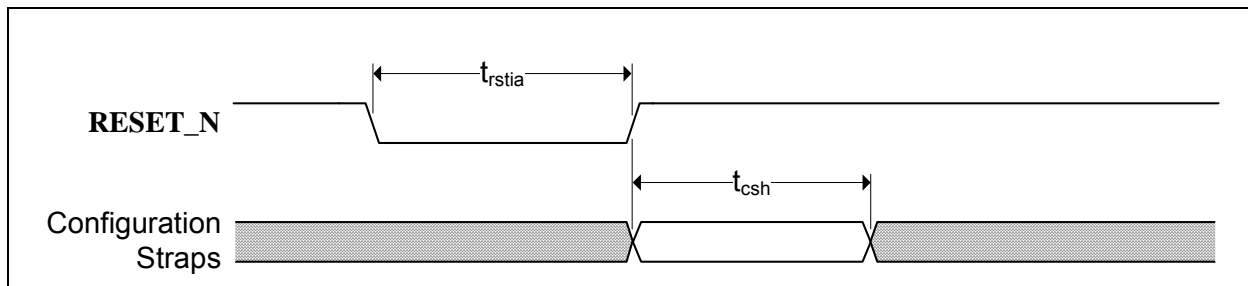

**TABLE 9-7: RESET\_N CONFIGURATION STRAP TIMING**

Symbol	Description	Min	Typ	Max	Units
$t_{rstia}$	<b>RESET_N</b> input assertion time	5			$\mu$ s
$t_{csh}$	Configuration strap pins hold after <b>RESET_N</b> deassertion	1			ms

**Note:** The clock input must be stable prior to **RESET\_N** deassertion.

Configuration strap latching and output drive timings shown assume that the Power-On reset has finished first otherwise the timings in Section 9.6.2, "Power-On and Configuration Strap Timing" apply.

## 9.6.4 USB TIMING

All device USB signals conform to the voltage, power, and timing characteristics/specifications as set forth in the *Universal Serial Bus Specification*. Please refer to the *Universal Serial Bus Revision 3.1 Specification*, available at <http://www.usb.org/developers/docs>.

## 9.6.5 I<sup>2</sup>C TIMING

All device I<sup>2</sup>C signals conform to the 400KHz Fast Mode (Fm) voltage, power, and timing characteristics/specifications as set forth in the *I<sup>2</sup>C-Bus Specification*. Please refer to the *I<sup>2</sup>C-Bus Specification*, available at [http://www.nxp.com/documents/user\\_manual/UM10204.pdf](http://www.nxp.com/documents/user_manual/UM10204.pdf).

## 9.6.6 SMBUS TIMING

All device SMBus signals conform to the voltage, power, and timing characteristics/specifications as set forth in the *System Management Bus Specification*. Please refer to the *System Management Bus Specification*, Version 1.0, available at <http://smbus.org/specs>.

# USB5734

## 9.6.7 SPI TIMING

This section specifies the SPI timing requirements for the device.

**FIGURE 9-5: SPI TIMING**

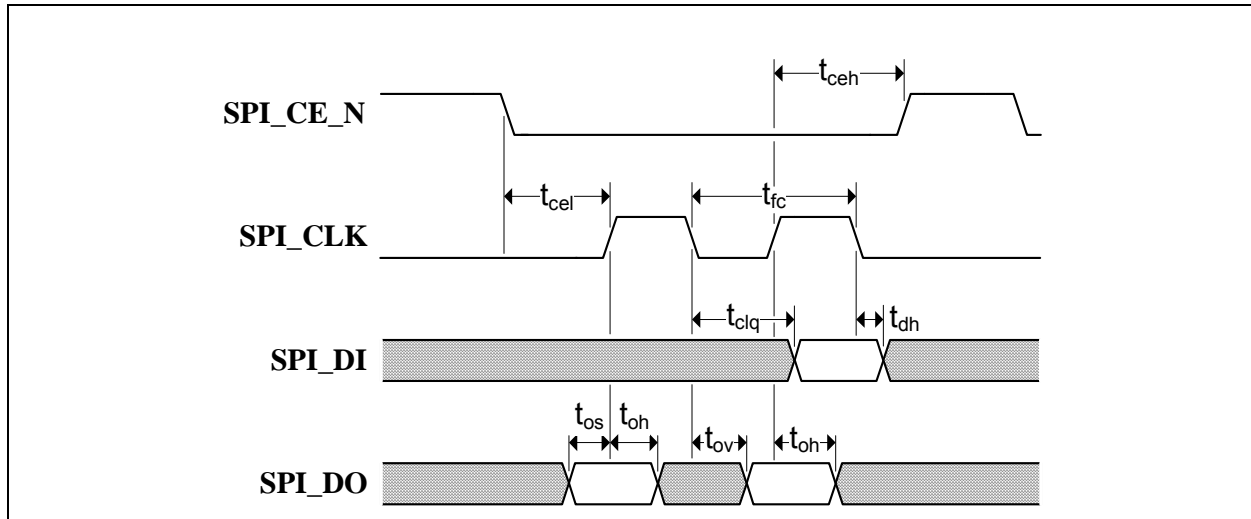

**TABLE 9-8: SPI TIMING (30 MHZ OPERATION)**

Symbol	Description	Min	Typ	Max	Units
$t_{fc}$	Clock frequency			30	MHz
$t_{ceh}$	Chip enable (SPI_CE_EN) high time	100			ns
$t_{clq}$	Clock to input data			13	ns
$t_{dh}$	Input data hold time	0			ns
$t_{os}$	Output setup time	5			ns
$t_{oh}$	Output hold time	5			ns
$t_{ov}$	Clock to output valid	4			ns
$t_{cel}$	Chip enable (SPI_CE_EN) low to first clock	12			ns
$t_{ceh}$	Last clock to chip enable (SPI_CE_EN) high	12			ns

**TABLE 9-9: SPI TIMING (60 MHZ OPERATION)**

Symbol	Description	Min	Typ	Max	Units
$t_{fc}$	Clock frequency			60	MHz
$t_{ceh}$	Chip enable (SPI_CE_EN) high time	50			ns
$t_{clq}$	Clock to input data			9	ns
$t_{dh}$	Input data hold time	0			ns
$t_{os}$	Output setup time	5			ns
$t_{oh}$	Output hold time	5			ns
$t_{ov}$	Clock to output valid	4			ns
$t_{cel}$	Chip enable (SPI_CE_EN) low to first clock	12			ns
$t_{ceh}$	Last clock to chip enable (SPI_CE_EN) high	12			ns



## 9.7 Clock Specifications

The device can accept either a 25MHz crystal or a 25MHz single-ended clock oscillator ( $\pm 50\text{ppm}$ ) input. If the single-ended clock oscillator method is implemented, **XTALO** should be left unconnected and **XTALI/CLK\_IN** should be driven with a nominal 0-3.3V clock signal. The input clock duty cycle is 40% minimum, 50% typical and 60% maximum.

It is recommended that a crystal utilizing matching parallel load capacitors be used for the crystal input/output signals (**XTALI/XTALO**). The following circuit design (Figure 9-6) and specifications (Table 9-10) are required to ensure proper operation.

**FIGURE 9-6: 25MHZ CRYSTAL CIRCUIT**

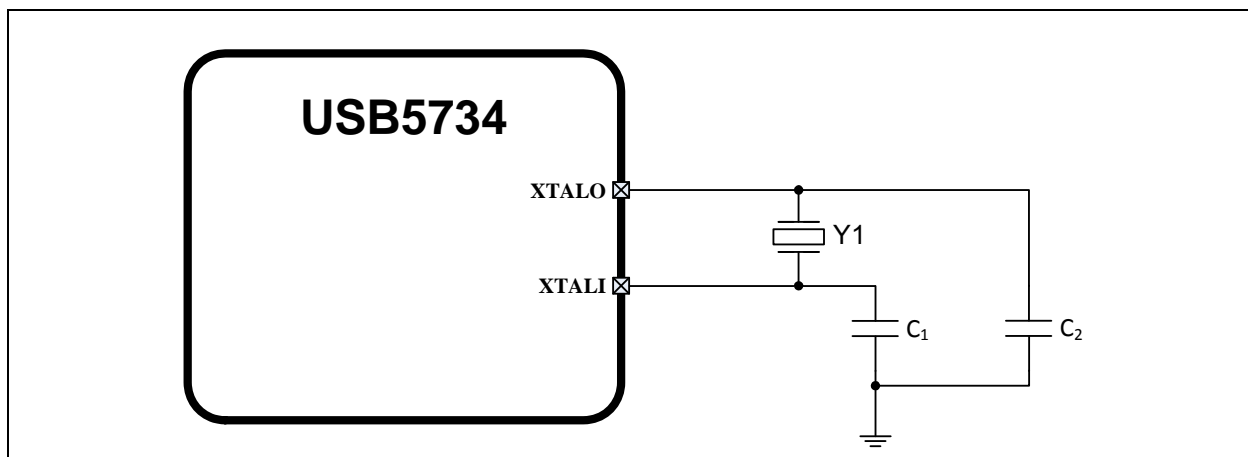

### 9.7.1 CRYSTAL SPECIFICATIONS

It is recommended that a crystal utilizing matching parallel load capacitors be used for the crystal input/output signals (**XTALI/XTALO**). Refer to Table 9-10 for the recommended crystal specifications.

**TABLE 9-10: CRYSTAL SPECIFICATIONS**

Parameter	Symbol	Min	Nom	Max	Units	Notes
Crystal Cut		AT, typ				
Crystal Oscillation Mode		Fundamental Mode				
Crystal Calibration Mode		Parallel Resonant Mode				
Frequency	$F_{\text{fund}}$	-	25.000	-	MHz	
Frequency Tolerance @ 25°C	$F_{\text{tol}}$	-	-	$\pm 50$	PPM	Note 7
Frequency Stability Over Temp	$F_{\text{temp}}$	-	-	$\pm 50$	PPM	Note 7
Frequency Deviation Over Time	$F_{\text{age}}$	-	$\pm 3$ to 5	-	PPM	
Total Allowable PPM Budget		-	-	$\pm 100$	PPM	Note 8
Shunt Capacitance	$C_O$	-	7 typ	-	pF	
Load Capacitance	$C_L$	-	20 typ	-	pF	
Drive Level	$P_W$	100	-	-	uW	
Equivalent Series Resistance	$R_1$	-	-	50	$\Omega$	
Operating Temperature Range		Note 8	-	Note 9	°C	
<b>XTALI/CLK_IN</b> Pin Capacitance		-	3 typ	-	pF	Note 10
<b>XTALO</b> Pin Capacitance		-	3 typ	-	pF	Note 10

**Note 7:** Frequency Deviation Over Time is also referred to as Aging.

# USB5734

---

**Note 8:** 0 °C for commercial version, -40 °C for industrial version.

**Note 9:** +70 °C for commercial version, +85 °C for industrial version.

**Note 10:** This number includes the pad, the bond wire and the lead frame. PCB capacitance is not included in this value. The **XTALI/CLK\_IN** pin, **XTALO** pin and PCB capacitance values are required to accurately calculate the value of the two external load capacitors. These two external load capacitors determine the accuracy of the 25.000 MHz frequency.

## 9.7.2 EXTERNAL REFERENCE CLOCK (**CLK\_IN**)

When using an external reference clock, the following input clock specifications are suggested:

- 25 MHz
- 50% duty cycle  $\pm 10\%$ ,  $\pm 100$  ppm
- Jitter < 100 ps RMS

## 10.0 PACKAGE INFORMATION

### 10.1 Package Marking Information

64-VQFN (9x9 mm)

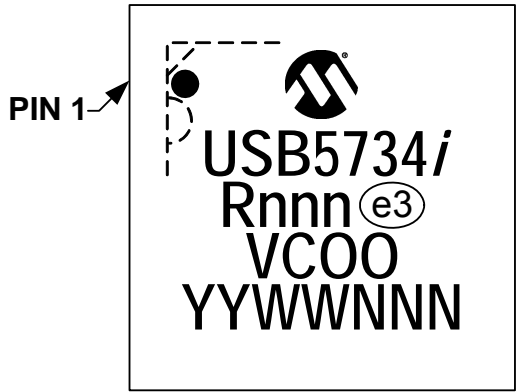

PIN 1

USB5734*i*  
Rnnn e3  
V  
COO  
YYWWNNN

<b>Legend:</b>	<i>i</i>	Temperature range designator (Blank = commercial, <i>i</i> = industrial)
	R	Product revision
	nnn	Internal code
	e3	Pb-free JEDEC® designator for Matte Tin (Sn)
	V	Plant of assembly
	COO	Country of origin
	YY	Year code (last two digits of calendar year)
	WW	Week code (week of January 1 is week '01')
	NNN	Alphanumeric traceability code

**Note:** In the event the full Microchip part number cannot be marked on one line, it will be carried over to the next line, thus limiting the number of available characters for customer-specific information.

\* Standard device marking consists of Microchip part number, year code, week code and traceability code. For device marking beyond this, certain price adders apply. Please check with your Microchip Sales Office. For QTP devices, any special marking adders are included in QTP price.

# USB5734

## 10.2 Package Drawings

**Note:** For the most current package drawings, see the Microchip Packaging Specification at: <http://www.microchip.com/packaging>.

**FIGURE 10-1: 64-VQFN PACKAGE (DRAWING)**

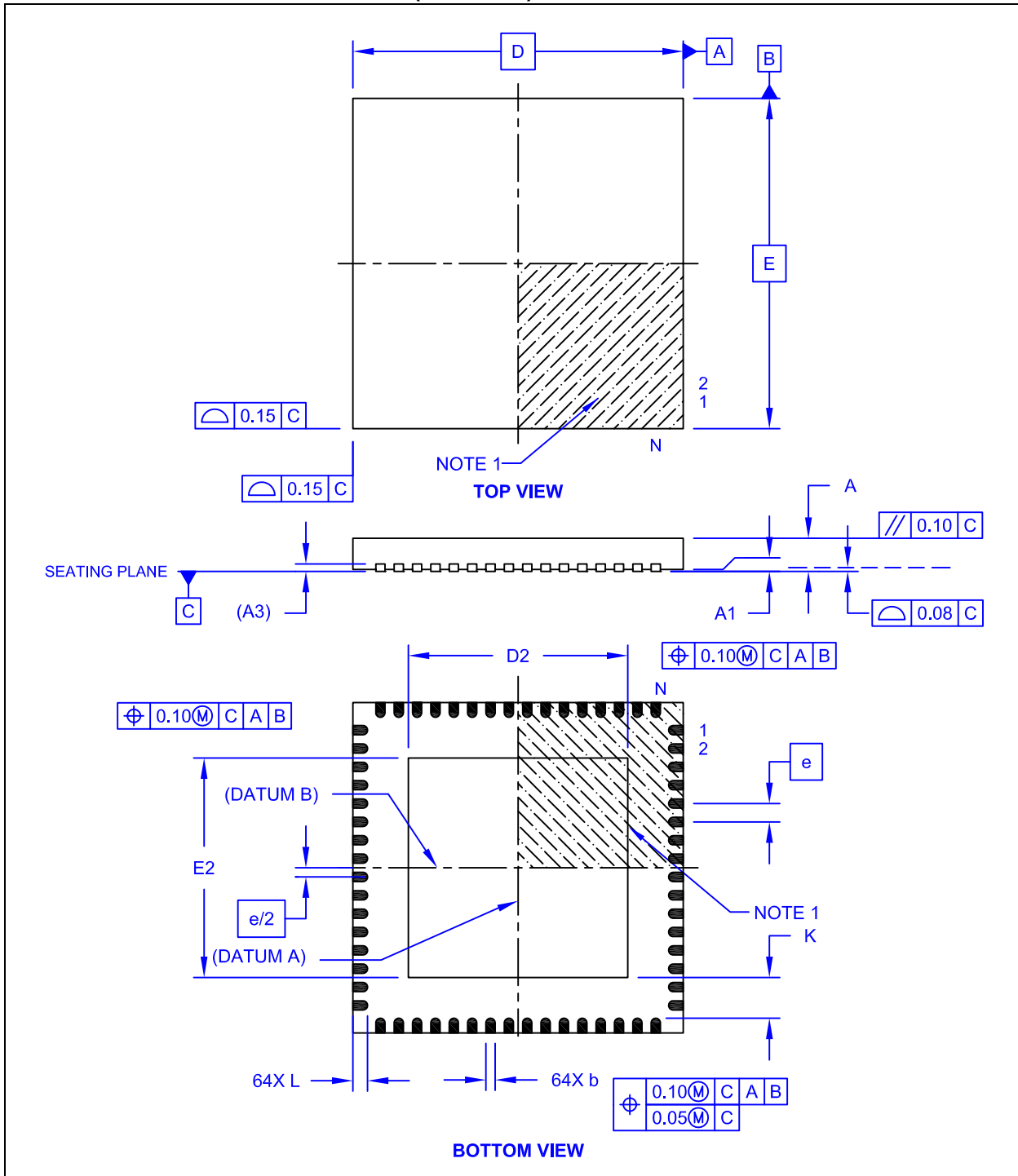

**FIGURE 10-2: 64-VQFN PACKAGE (DIMENSIONS)**

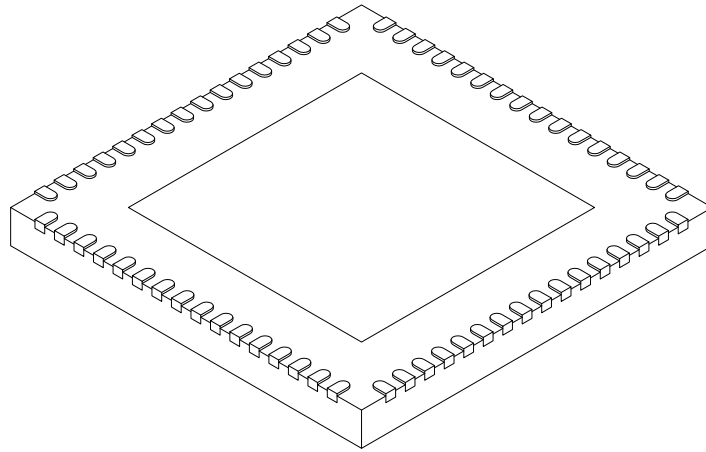

Dimension Limits	Units	MILLIMETERS		
		MIN	NOM	MAX
Number of Pins	N	64		
Pitch	e	0.50 BSC		
Overall Height	A	0.80	0.90	1.00
Standoff	A1	0.00	0.02	0.05
Contact Thickness	A3	0.20 REF		
Overall Width	E	9.00 BSC		
Exposed Pad Width	E2	5.90	6.00	6.10
Overall Length	D	9.00 BSC		
Exposed Pad Length	D2	5.90	6.00	6.10
Contact Width	b	0.18	0.25	0.30
Contact Length	L	0.30	0.40	0.50
Contact-to-Exposed Pad	K	0.90	1.10	-

**Notes:**

1. Pin 1 visual index feature may vary, but must be located within the hatched area.
2. Package is saw singulated.
3. Dimensioning and tolerancing per ASME Y14.5M.
  - BSC: Basic Dimension. Theoretically exact value shown without tolerances.
  - REF: Reference Dimension, usually without tolerance, for information purposes only.

# USB5734

FIGURE 10-3: 64-VQFN LAND PATTERN

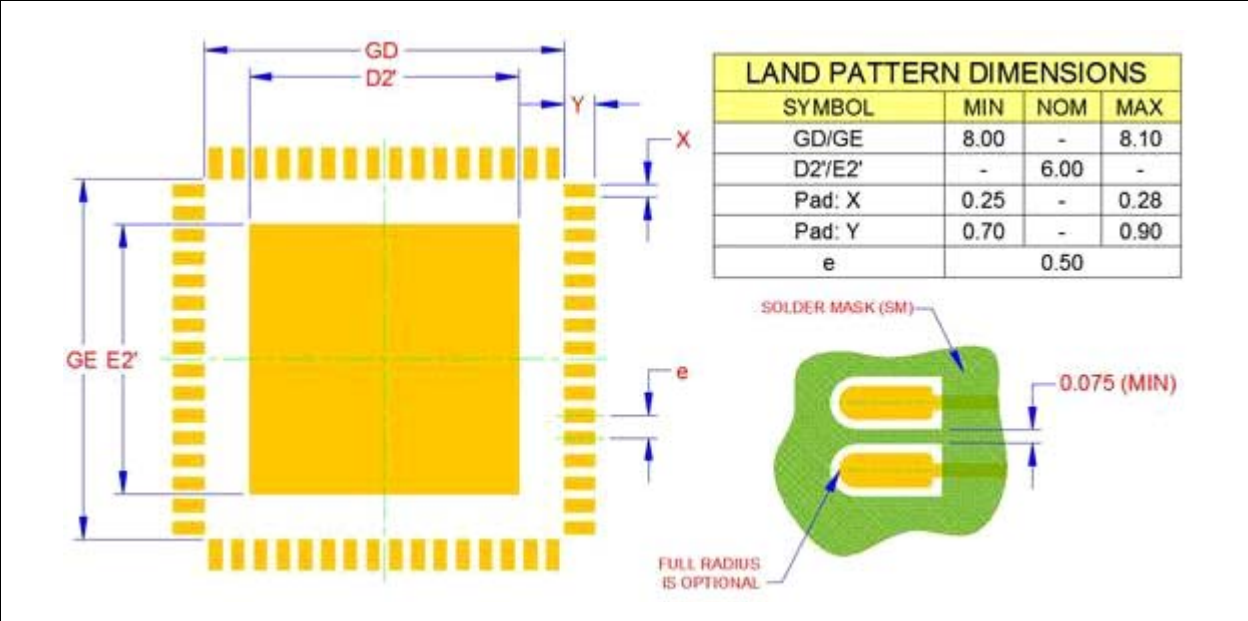

## APPENDIX A: DATA SHEET REVISION HISTORY

TABLE A-1: REVISION HISTORY

Revision Level & Date	Section/Figure/Entry	Correction
DS00001854D (06-02-16)	<a href="#">Section 10.0, Package Information</a>	Added top marking information and land pattern drawing.
	All	Updated "SQFN" references to "VQFN". Name change only.
	<a href="#">Section 8.6.2.1, Port Power Control using USB Power Switch</a>	Added additional information on overcurrent detection methods.
	<a href="#">Section 9.6.1, Power Supply and RESET_N Sequence Timing</a>	Added Power Supply and RESET_N Sequence Timing section.
	<a href="#">Section 9.6.5, I2C Timing</a>	"100kHz Standard Mode (Sm)" updated to "400kHz Fast Mode (Fm)", since the device supports up to 400kHz I <sup>2</sup> C operation.
DS00001854C (06-22-15)	All	<ul style="list-style-type: none"> <li>Updated "USB 3.0" references to "USB 3.1 Gen 1" throughout the document</li> <li>Updated USB specification references</li> <li>Misc. typos</li> </ul>
DS00001854B (04-16-15)	Features	Changed Environmental feature bullet from "4kV HBM JESD22-A114F ESD protection" to "3kV HBM JESD22-A114F ESD protection"
	<a href="#">Section 9.2, Operating Conditions**</a>	Changed XTALI/CLK_IN Voltage to -0.3V to +3.6V
	<a href="#">Table 9-10, "Crystal Specifications"</a>	Total Allowable PPM budget changed to 100ppm, removed notes under table regarding "Frequency Tolerance" and "Frequency and Transmitter Clock Frequency"
	<a href="#">Section 9.7.2, External Reference Clock (CLK_IN)</a>	Changed +-350ppm to +-100 ppm
	<a href="#">Figure 3-1, "64-VQFN Pin Assignments", Table 3-1, "64-VQFN Pin Assignments"</a>	Modified pin 32 from "PRT_CTL4/GANG_PWR" to "PRT_CTL4/ <u>GANG_PWR</u> "
	<a href="#">Table 3-5, "USB Port Control Pin Descriptions"</a>	Revised description of Pin 1, <b>GANG_PWR</b>
	<a href="#">Table 1-1, "General Terms" and throughout document</a>	Replaced the term Hub Controller with Hub Feature Controller, added definition in <a href="#">Table 1-1, "General Terms"</a> .
	<a href="#">Section 6.1.2, SMBus Accessible Functions</a>	Added web link to AN1903
		Removed PortMap feature throughout document.
	<a href="#">Table 3-8, "Miscellaneous Pin Descriptions"</a>	Modified RESET_N pin description
	<a href="#">Section 8.4, Link Power Management (LPM)</a>	Removed "per the USB 3.0 Specification" from the first sentence. Removed last sentence "For additional information, refer to the USB 3.0 Specification."
	<a href="#">Table 9-2, "MAXIMUM Power Dissipation"</a>	Added <a href="#">Table 9-2</a> .

# USB5734

**TABLE A-1: REVISION HISTORY (CONTINUED)**

Revision Level & Date	Section/Figure/Entry	Correction
	Section 9.7, "Clock Specifications", Figure 9-6, Table 9-10, "Crystal Specifications"	Updated these sections.
	Section 9.7.2, External Reference Clock (CLK_IN)	Oscillator changed from "35MHz" to "25 MHz"
	Section 9.6.7, SPI Timing	Removed SPI interface configure note
	Section 9.1, Absolute Maximum Ratings*	Added "Positive voltage on USB 3.0 USB3UP_ <i>xxxx</i> and USB3DN_ <i>xxxx</i> signal pins, with respect to ground...1.32 V
		Changed XTALI positive voltage from 2.1V to 3.63V.
		Changed "USB 3.0 DP/DM Signal Pins Voltage" to "USB 3.0 USB3UP_ <i>xxxx</i> and USB3DN_ <i>xxxx</i> Signal Pins Voltage"
	Section 8.6.2, "Port Connection in Combined Mode," on page 38	Added note under <a href="#">Section 8.6.2</a>
	Product Identification System on page 59	Updated ordering information
	Section 9.1, "Absolute Maximum Ratings*," on page 42	Updated +1.2V supply voltage absolute max value. Added HBM ESD performance specification.
	Table 9-1, "Package Thermal Parameters," on page 43	Added package thermal parameters.
	Worldwide Sales and Service	Updated Worldwide Sales Listing
	Table 9-4, "I/O DC Electrical Characteristics," on page 45	Updated I buffer type high input level max. Added IS buffer type Schmitt trigger hysteresis values and note for <b>PROG_FUNC3</b> pin.
	Cover, All	Updated document title to "4-Port SS/HS Controller Hub" Removed PortMap references. Removed sentence: "These circuits are used to detect the attachment and type of a USB charger and provide an interrupt output to indicate charger information is available to be read from the device's status registers via the serial interface."
	FIGURE 3-1: 64-VQFN Pin Assignments on page 8	Added configuration strap note under figure.
	Table 3-7, "Programmable Function Pin Descriptions," on page 14, Table 3-16, Table 3-17, Table 3-18, Table 3-19, Table 3-20, Table 3-21	Added note to <b>PROG_FUNC[7:1]</b> buffer type column, which indicates the following: "The <b>PROG_FUNC2</b> buffer type is I/O6. The <b>PROG_FUNC7</b> buffer type is I/O10. All other <b>PROG_FUNCx</b> pins have a buffer type of I/O12."
	Table 3-16, Table 3-17, Table 3-18, Table 3-19, Table 3-20, Table 3-21	Updated <b>PROG_FUNC2</b> and <b>PROG_FUNC7</b> buffer type definitions to reflect O6 and O10 outputs, respectively.
	Table 3-10, "Buffer Types," on page 16, Table 9-4, "I/O DC Electrical Characteristics," on page 45	Added O10 buffer type



**TABLE A-1: REVISION HISTORY (CONTINUED)**

Revision Level & Date	Section/Figure/Entry	Correction
	<a href="#">Table 3-16, "Configuration 1 PROG_FUNC[7:1] Function Assignment," on page 20</a>	Updated <b>PROG_FUNC7</b> name in Configuration 1 - Mixed Mode from <b>SUSP_IND</b> to <b>USB2_SUSP_IND</b> and clarified description.
	<a href="#">Section 3.4.5.6, "Configuration 6 - Full UART Mode," on page 26</a>	Added note: "When flow control is disabled, <b>UART_nCTS</b> , <b>UART_nDCD</b> , and <b>UART_nDSR</b> must not be left floating. In this case, these pins should include external pull-downs to maintain UART communication in Full UART Mode with no flow control."
	<a href="#">Section 8.2, "FlexConnect," on page 36</a>	Updated second paragraph to clarify proper <b>FLEXCONNECT</b> operation.
	<a href="#">Section 8.5, "Remote Wakeup Indicator," on page 38</a>	Updated <b>SUSP_IND</b> to <b>USB2_SUSP_IND</b> and clarified the function is for <b>USB2.0</b> only.
DS00001854A (12-15-14)	All	Initial Release

# USB5734

---

---

## THE MICROCHIP WEB SITE

Microchip provides online support via our WWW site at [www.microchip.com](http://www.microchip.com). This web site is used as a means to make files and information easily available to customers. Accessible by using your favorite Internet browser, the web site contains the following information:

- **Product Support** – Data sheets and errata, application notes and sample programs, design resources, user's guides and hardware support documents, latest software releases and archived software
- **General Technical Support** – Frequently Asked Questions (FAQ), technical support requests, online discussion groups, Microchip consultant program member listing
- **Business of Microchip** – Product selector and ordering guides, latest Microchip press releases, listing of seminars and events, listings of Microchip sales offices, distributors and factory representatives

## CUSTOMER CHANGE NOTIFICATION SERVICE

Microchip's customer notification service helps keep customers current on Microchip products. Subscribers will receive e-mail notification whenever there are changes, updates, revisions or errata related to a specified product family or development tool of interest.

To register, access the Microchip web site at [www.microchip.com](http://www.microchip.com). Under "Support", click on "Customer Change Notification" and follow the registration instructions.

## CUSTOMER SUPPORT

Users of Microchip products can receive assistance through several channels:

- Distributor or Representative
- Local Sales Office
- Field Application Engineer (FAE)
- Technical Support

Customers should contact their distributor, representative or field application engineer (FAE) for support. Local sales offices are also available to help customers. A listing of sales offices and locations is included in the back of this document.

**Technical support is available through the web site at: <http://www.microchip.com/support>**

## PRODUCT IDENTIFICATION SYSTEM

To order or obtain information, e.g., on pricing or delivery, refer to the factory or the listed sales office.

<u>PART NO.</u>	[X]	[-X]	/	XX
Device	Tape & Reel Option	Temperature Range		Package
<b>Device:</b> USB5734  <b>Tape and Reel Option:</b> Blank = Standard packaging (tray) T = Tape and Reel ( <a href="#">Note 1</a> )  <b>Temperature Range:</b> Blank = 0°C to +70°C (Commercial) I = -40°C to +85°C (Industrial)  <b>Package:</b> MR = 64-pin VQFN				
				<b>Examples:</b> a) USB5734/MR Tray, Commercial temp., 64-pin VQFN  b) USB5734-I/MR Tray, Industrial temp., 64-pin VQFN  c) USB5734T-I/MR Tape & reel, Industrial temp., 64-pin VQFN  d) USB5734T/MR Tape & reel, Commercial temp., 64-pin VQFN
				<b>Note 1:</b> Tape and Reel identifier only appears in the catalog part number description. This identifier is used for ordering purposes and is not printed on the device package. Check with your Microchip Sales Office for package availability with the Tape and Reel option.

# USB5734

---

---

## Note the following details of the code protection feature on Microchip devices:

- Microchip products meet the specification contained in their particular Microchip Data Sheet.
- Microchip believes that its family of products is one of the most secure families of its kind on the market today, when used in the intended manner and under normal conditions.
- There are dishonest and possibly illegal methods used to breach the code protection feature. All of these methods, to our knowledge, require using the Microchip products in a manner outside the operating specifications contained in Microchip's Data Sheets. Most likely, the person doing so is engaged in theft of intellectual property.
- Microchip is willing to work with the customer who is concerned about the integrity of their code.
- Neither Microchip nor any other semiconductor manufacturer can guarantee the security of their code. Code protection does not mean that we are guaranteeing the product as “unbreakable.”

Code protection is constantly evolving. We at Microchip are committed to continuously improving the code protection features of our products. Attempts to break Microchip's code protection feature may be a violation of the Digital Millennium Copyright Act. If such acts allow unauthorized access to your software or other copyrighted work, you may have a right to sue for relief under that Act.

---

Information contained in this publication regarding device applications and the like is provided only for your convenience and may be superseded by updates. It is your responsibility to ensure that your application meets with your specifications. MICROCHIP MAKES NO REPRESENTATIONS OR WARRANTIES OF ANY KIND WHETHER EXPRESS OR IMPLIED, WRITTEN OR ORAL, STATUTORY OR OTHERWISE, RELATED TO THE INFORMATION, INCLUDING BUT NOT LIMITED TO ITS CONDITION, QUALITY, PERFORMANCE, MERCHANTABILITY OR FITNESS FOR PURPOSE. Microchip disclaims all liability arising from this information and its use. Use of Microchip devices in life support and/or safety applications is entirely at the buyer's risk, and the buyer agrees to defend, indemnify and hold harmless Microchip from any and all damages, claims, suits, or expenses resulting from such use. No licenses are conveyed, implicitly or otherwise, under any Microchip intellectual property rights unless otherwise stated.

## Trademarks

The Microchip name and logo, the Microchip logo, AnyRate, dsPIC, FlashFlex, flexPWR, Helder, JukeBlox, KeeLoq, KeeLoq logo, Klear, LANCheck, LINK MD, MediaLB, MOST, MOST logo, MPLAB, OptoLyzer, PIC, PICSTART, PIC32 logo, RightTouch, SpyNIC, SST, SST Logo, SuperFlash and UNI/O are registered trademarks of Microchip Technology Incorporated in the U.S.A. and other countries.

ClockWorks, The Embedded Control Solutions Company, ETHERSYNCH, Hyper Speed Control, HyperLight Load, IntelliMOS, mTouch, Precision Edge, and QUIET-WIRE are registered trademarks of Microchip Technology Incorporated in the U.S.A.

Analog-for-the-Digital Age, Any Capacitor, AnyIn, AnyOut, BodyCom, chipKIT, chipKIT logo, CodeGuard, dsPICDEM, dsPICDEM.net, Dynamic Average Matching, DAM, ECAN, EtherGREEN, In-Circuit Serial Programming, ICSP, Inter-Chip Connectivity, JitterBlocker, KlearNet, KlearNet logo, MiWi, motorBench, MPASM, MPF, MPLAB Certified logo, MPLIB, MPLINK, MultiTRAK, NetDetach, Omniscient Code Generation, PICDEM, PICDEM.net, PICkit, PICtail, PureSilicon, RightTouch logo, REAL ICE, Ripple Blocker, Serial Quad I/O, SQI, SuperSwitcher, SuperSwitcher II, Total Endurance, TSHARC, USBCheck, VariSense, ViewSpan, WiperLock, Wireless DNA, and ZENA are trademarks of Microchip Technology Incorporated in the U.S.A. and other countries.

SQTP is a service mark of Microchip Technology Incorporated in the U.S.A.

Silicon Storage Technology is a registered trademark of Microchip Technology Inc. in other countries.

GestIC is a registered trademarks of Microchip Technology Germany II GmbH & Co. KG, a subsidiary of Microchip Technology Inc., in other countries.

All other trademarks mentioned herein are property of their respective companies.

© 2015-2016, Microchip Technology Incorporated, Printed in the U.S.A., All Rights Reserved.

ISBN: 9781522406600

**QUALITY MANAGEMENT SYSTEM**  
**CERTIFIED BY DNV**  
**== ISO/TS 16949 ==**

*Microchip received ISO/TS-16949:2009 certification for its worldwide headquarters, design and wafer fabrication facilities in Chandler and Tempe, Arizona; Gresham, Oregon and design centers in California and India. The Company's quality system processes and procedures are for its PIC® MCUs and dsPIC® DSCs, KEELoq® code hopping devices, Serial EEPROMs, microperipherals, nonvolatile memory and analog products. In addition, Microchip's quality system for the design and manufacture of development systems is ISO 9001:2000 certified.*



## Worldwide Sales and Service

### AMERICAS

**Corporate Office**  
2355 West Chandler Blvd.  
Chandler, AZ 85224-6199  
Tel: 480-792-7200  
Fax: 480-792-7277  
Technical Support:  
<http://www.microchip.com/support>  
Web Address:  
[www.microchip.com](http://www.microchip.com)

**Atlanta**  
Duluth, GA  
Tel: 678-957-9614  
Fax: 678-957-1455

**Austin, TX**  
Tel: 512-257-3370

**Boston**  
Westborough, MA  
Tel: 774-760-0087  
Fax: 774-760-0088

**Chicago**  
Itasca, IL  
Tel: 630-285-0071  
Fax: 630-285-0075

**Cleveland**  
Independence, OH  
Tel: 216-447-0464  
Fax: 216-447-0643

**Dallas**  
Addison, TX  
Tel: 972-818-7423  
Fax: 972-818-2924

**Detroit**  
Novi, MI  
Tel: 248-848-4000

**Houston, TX**  
Tel: 281-894-5983

**Indianapolis**  
Noblesville, IN  
Tel: 317-773-8323  
Fax: 317-773-5453

**Los Angeles**  
Mission Viejo, CA  
Tel: 949-462-9523  
Fax: 949-462-9608

**New York, NY**  
Tel: 631-435-6000

**San Jose, CA**  
Tel: 408-735-9110

**Canada - Toronto**  
Tel: 905-673-0699  
Fax: 905-673-6509

### ASIA/PACIFIC

**Asia Pacific Office**  
Suites 3707-14, 37th Floor  
Tower 6, The Gateway  
Harbour City, Kowloon

**Hong Kong**  
Tel: 852-2943-5100  
Fax: 852-2401-3431

**Australia - Sydney**  
Tel: 61-2-9868-6733  
Fax: 61-2-9868-6755

**China - Beijing**  
Tel: 86-10-8569-7000  
Fax: 86-10-8528-2104

**China - Chengdu**  
Tel: 86-28-8665-5511  
Fax: 86-28-8665-7889

**China - Chongqing**  
Tel: 86-23-8980-9588  
Fax: 86-23-8980-9500

**China - Dongguan**  
Tel: 86-769-8702-9880

**China - Hangzhou**  
Tel: 86-571-8792-8115  
Fax: 86-571-8792-8116

**China - Hong Kong SAR**  
Tel: 852-2943-5100  
Fax: 852-2401-3431

**China - Nanjing**  
Tel: 86-25-8473-2460  
Fax: 86-25-8473-2470

**China - Qingdao**  
Tel: 86-532-8502-7355  
Fax: 86-532-8502-7205

**China - Shanghai**  
Tel: 86-21-5407-5533  
Fax: 86-21-5407-5066

**China - Shenyang**  
Tel: 86-24-2334-2829  
Fax: 86-24-2334-2393

**China - Shenzhen**  
Tel: 86-755-8864-2200  
Fax: 86-755-8203-1760

**China - Wuhan**  
Tel: 86-27-5980-5300  
Fax: 86-27-5980-5118

**China - Xian**  
Tel: 86-29-8833-7252  
Fax: 86-29-8833-7256

### ASIA/PACIFIC

**China - Xiamen**  
Tel: 86-592-2388138  
Fax: 86-592-2388130

**China - Zhuhai**  
Tel: 86-756-3210040  
Fax: 86-756-3210049

**India - Bangalore**  
Tel: 91-80-3090-4444  
Fax: 91-80-3090-4123

**India - New Delhi**  
Tel: 91-11-4160-8631  
Fax: 91-11-4160-8632

**India - Pune**  
Tel: 91-20-3019-1500

**Japan - Osaka**  
Tel: 81-6-6152-7160  
Fax: 81-6-6152-9310

**Japan - Tokyo**  
Tel: 81-3-6880-3770  
Fax: 81-3-6880-3771

**Korea - Daegu**  
Tel: 82-53-744-4301  
Fax: 82-53-744-4302

**Korea - Seoul**  
Tel: 82-2-554-7200  
Fax: 82-2-558-5932 or  
82-2-558-5934

**Malaysia - Kuala Lumpur**  
Tel: 60-3-6201-9857  
Fax: 60-3-6201-9859

**Malaysia - Penang**  
Tel: 60-4-227-8870  
Fax: 60-4-227-4068

**Philippines - Manila**  
Tel: 63-2-634-9065  
Fax: 63-2-634-9069

**Singapore**  
Tel: 65-6334-8870  
Fax: 65-6334-8850

**Taiwan - Hsin Chu**  
Tel: 886-3-5778-366  
Fax: 886-3-5770-955

**Taiwan - Kaohsiung**  
Tel: 886-7-213-7828

**Taiwan - Taipei**  
Tel: 886-2-2508-8600  
Fax: 886-2-2508-0102

**Thailand - Bangkok**  
Tel: 66-2-694-1351  
Fax: 66-2-694-1350

### EUROPE

**Austria - Wels**  
Tel: 43-7242-2244-39  
Fax: 43-7242-2244-393

**Denmark - Copenhagen**  
Tel: 45-4450-2828  
Fax: 45-4485-2829

**France - Paris**  
Tel: 33-1-69-53-63-20  
Fax: 33-1-69-30-90-79

**Germany - Dusseldorf**  
Tel: 49-2129-3766400

**Germany - Karlsruhe**  
Tel: 49-721-625370

**Germany - Munich**  
Tel: 49-89-627-144-0  
Fax: 49-89-627-144-44

**Italy - Milan**  
Tel: 39-0331-742611  
Fax: 39-0331-466781

**Italy - Venice**  
Tel: 39-049-7625286

**Netherlands - Drunen**  
Tel: 31-416-690399  
Fax: 31-416-690340

**Poland - Warsaw**  
Tel: 48-22-3325737

**Spain - Madrid**  
Tel: 34-91-708-08-90  
Fax: 34-91-708-08-91

**Sweden - Stockholm**  
Tel: 46-8-5090-4654

**UK - Wokingham**  
Tel: 44-118-921-5800  
Fax: 44-118-921-5820

07/14/15