

UJA1164A

Mini high-speed CAN system basis chip with Standby mode & watchdog

Rev. 1 — 23 August 2019

Product data sheet

1. General description

The UJA1164A is a mini high-speed CAN System Basis Chip (SBC) containing an ISO 11898-2:2016 and SAE J2284-1 to SAE J2284-5 compliant HS-CAN transceiver and an integrated 5 V/100 mA supply for a microcontroller. It also features a watchdog and a Serial Peripheral Interface (SPI). The UJA1164A can be operated in very-low-current Standby mode with bus wake-up capability and supports 11898-2:2016 compliant autonomous CAN biasing.

This implementation enables reliable communication in the CAN FD fast phase at data rates up to 5 Mbit/s.

A number of configuration settings are stored in non-volatile memory, allowing the SBC to be adapted for use in a specific application. This makes it possible to configure the power-on behavior of the UJA1164A to meet the requirements of different applications.

2. Features and benefits

2.1 General

- ISO 11898-2:2016 and SAE J2284-1 to SAE J2284-5 compliant high-speed CAN transceiver
- Hardware and software compatible with the UJA116x product family and with improved EMC performance
- Loop delay symmetry timing enables reliable communication at data rates up to 5 Mbit/s in the CAN FD fast phase
- Autonomous bus biasing according to ISO 11898-6
- Fully integrated 5 V/100 mA low-drop voltage regulator for 5 V microcontroller supply (V1)
- Bus connections are truly floating when power to pin BAT is off

2.2 Designed for automotive applications

- ± 8 kV ElectroStatic Discharge (ESD) protection, according to the Human Body Model (HBM) on the CAN bus pins
- ± 6 kV ESD protection, according to IEC TS 62228 on the CAN bus pins and on pin BAT
- CAN bus pins short-circuit proof to ± 58 V
- Battery and CAN bus pins protected against automotive transients according to ISO 7637-3
- Very low quiescent current in Standby mode with full wake-up capability



- Leadless HVSON14 package (3.0 mm × 4.5 mm) with improved Automated Optical Inspection (AOI) capability and low thermal resistance
- Dark green product (halogen free and Restriction of Hazardous Substances (RoHS) compliant)

2.3 Low-drop voltage regulator for 5 V microcontroller supply (V1)

- 5 V nominal output; ±2 % accuracy
- 100 mA output current capability
- Current limiting above 150 mA
- On-resistance of 5 Ω (max)
- Support for microcontroller RAM retention down to a battery voltage of 2 V
- Undervoltage reset with selectable detection thresholds: 60 %, 70 %, 80 % or 90 % of output voltage
- Excellent transient response with a 4.7 μF ceramic output capacitor
- Short-circuit to GND/overload protection on pin V1

2.4 Power Management

- Standby mode featuring very low supply current; voltage V1 remains active to maintain the supply to the microcontroller
- Remote wake-up capability via standard CAN wake-up pattern
- Wake-up source recognition
- Remote wake-up can be disabled to reduce current consumption

2.5 System control and diagnostic features

- Mode control via the Serial Peripheral Interface (SPI)
- Overtemperature warning and shutdown
- Watchdog with independent clock source
- Watchdog can be operated in Window, Timeout and Autonomous modes
- Optional cyclic wake-up in watchdog Timeout mode
- Watchdog automatically re-enabled when wake-up event captured
- Watchdog period selectable between 8 ms and 4 s
- Supports remote flash programming via the CAN bus
- 16-, 24- and 32-bit SPI for configuration, control and diagnosis
- Bidirectional reset pin with variable power-on reset length to support a variety of microcontrollers
- Configuration of selected functions via non-volatile memory

3. Ordering information

Table 1. Ordering information

Type number	Package		
	Name	Description	Version
UJA1164ATK	HVSON14	plastic thermal enhanced very thin small outline package; no leads; 14 terminals; body 3 ´ 4.5 ´ 0.85 mm	SOT1086-2

4. Block diagram

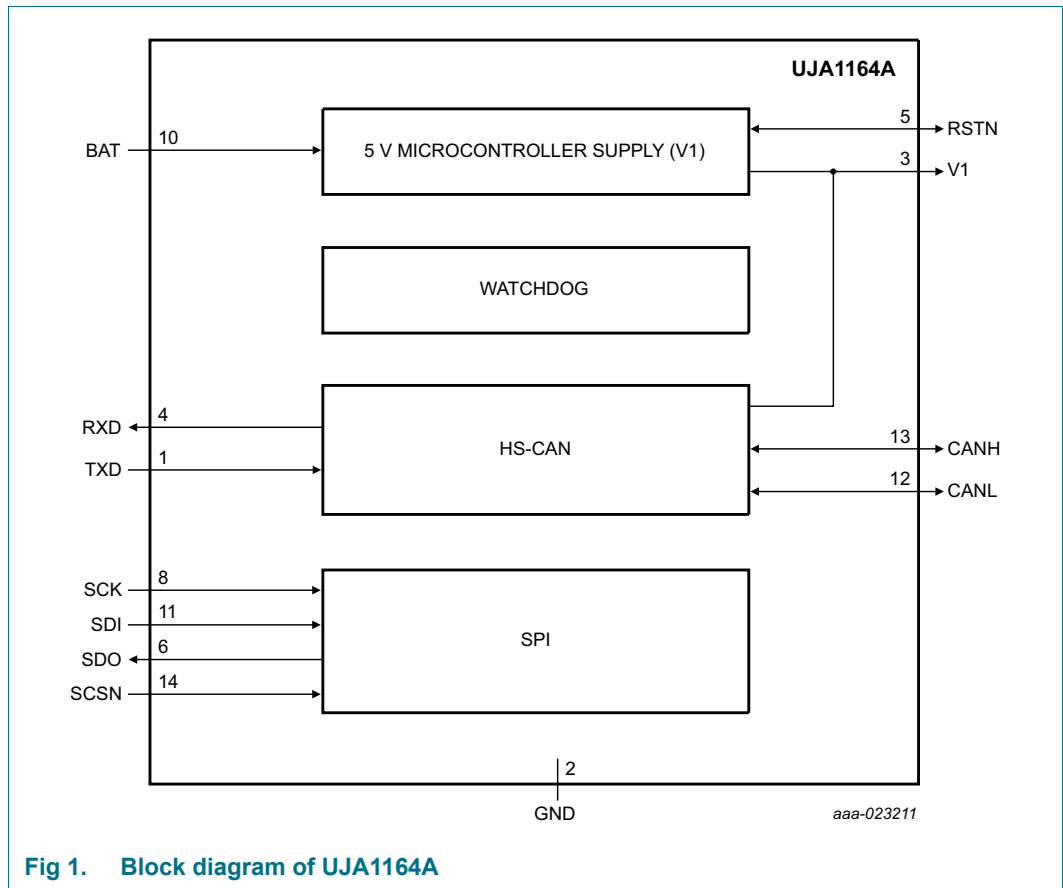
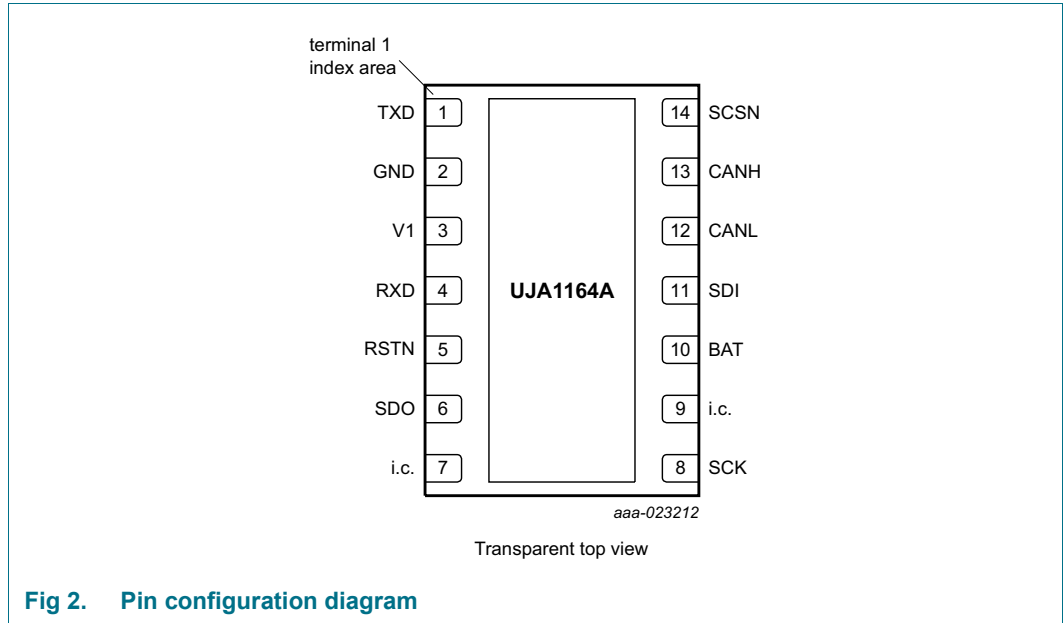

Fig 1. Block diagram of UJA1164A

5. Pinning information

5.1 Pinning



5.2 Pin description

Table 2. Pin description

Symbol	Pin	Description
TXD	1	transmit data input
GND	2 ^[1]	ground
V1	3	5 V microcontroller supply voltage
RXD	4	receive data output; reads out data from the bus lines
RSTN	5	reset input/output
SDO	6	SPI data output
i.c.	7	internally connected; should be left floating or connected to GND
SCK	8	SPI clock input
i.c.	9	internally connected; should be left floating or connected to GND
BAT	10	battery supply voltage
SDI	11	SPI data input
CANL	12	LOW-level CAN bus line
CANH	13	HIGH-level CAN bus line
SCSN	14	SPI chip select input

[1] The exposed die pad at the bottom of the package allows for better heat dissipation and grounding from the SBC via the printed circuit board. For enhanced thermal and electrical performance, it is recommended to solder the exposed die pad to GND.

6. Functional description

6.1 System controller

The system controller manages register configuration and controls the internal functions of the UJA1164A. Detailed device status information is collected and made available to the microcontroller.

6.1.1 Operating modes

The system controller contains a state machine that supports six operating modes: Normal, Standby, Reset, Forced Normal, Overtemp and Off. The state transitions are illustrated in [Figure 3](#).

6.1.1.1 Normal mode

Normal mode is the active operating mode. In this mode, all the hardware on the device is available and can be activated (see [Table 3](#)). Voltage regulator V1 is enabled to supply the microcontroller.

The CAN interface can be configured to be active and thus to support normal CAN communication. Depending on the SPI register settings, the watchdog may be running in Window or Timeout mode.

Normal mode can be selected from Standby mode via an SPI command (MC = 111).

6.1.1.2 Standby mode

Standby mode is the UJA1164A's power saving mode, offering reduced current consumption. The transceiver is unable to transmit or receive data in Standby mode. The SPI remains enabled and V1 is still active; the watchdog is active (in Timeout mode) if enabled.

If remote CAN wake-up is enabled (CWE = 1; see [Table 24](#)), the receiver monitors bus activity for a wake-up request. The bus pins are biased to GND (via $R_{i(cm)}$) when the bus is inactive for $t > t_{to(silence)}$ and at approximately 2.5 V when there is activity on the bus (autonomous biasing).

Pin RXD is forced LOW when any enabled wake-up event is detected. This can be either a regular wake-up (via the CAN bus) or a diagnostic wake-up such as an overtemperature event (see [Section 6.8](#)).

The UJA1164A switches to Standby mode via Reset mode:

- from Off mode if the battery voltage rises above the power-on detection threshold ($V_{th(det)pon}$)
- from Overtemp mode if the chip temperature falls below the overtemperature protection release threshold, $T_{th(rel)otp}$

Standby mode can also be selected from Normal mode via an SPI command (MC = 100).

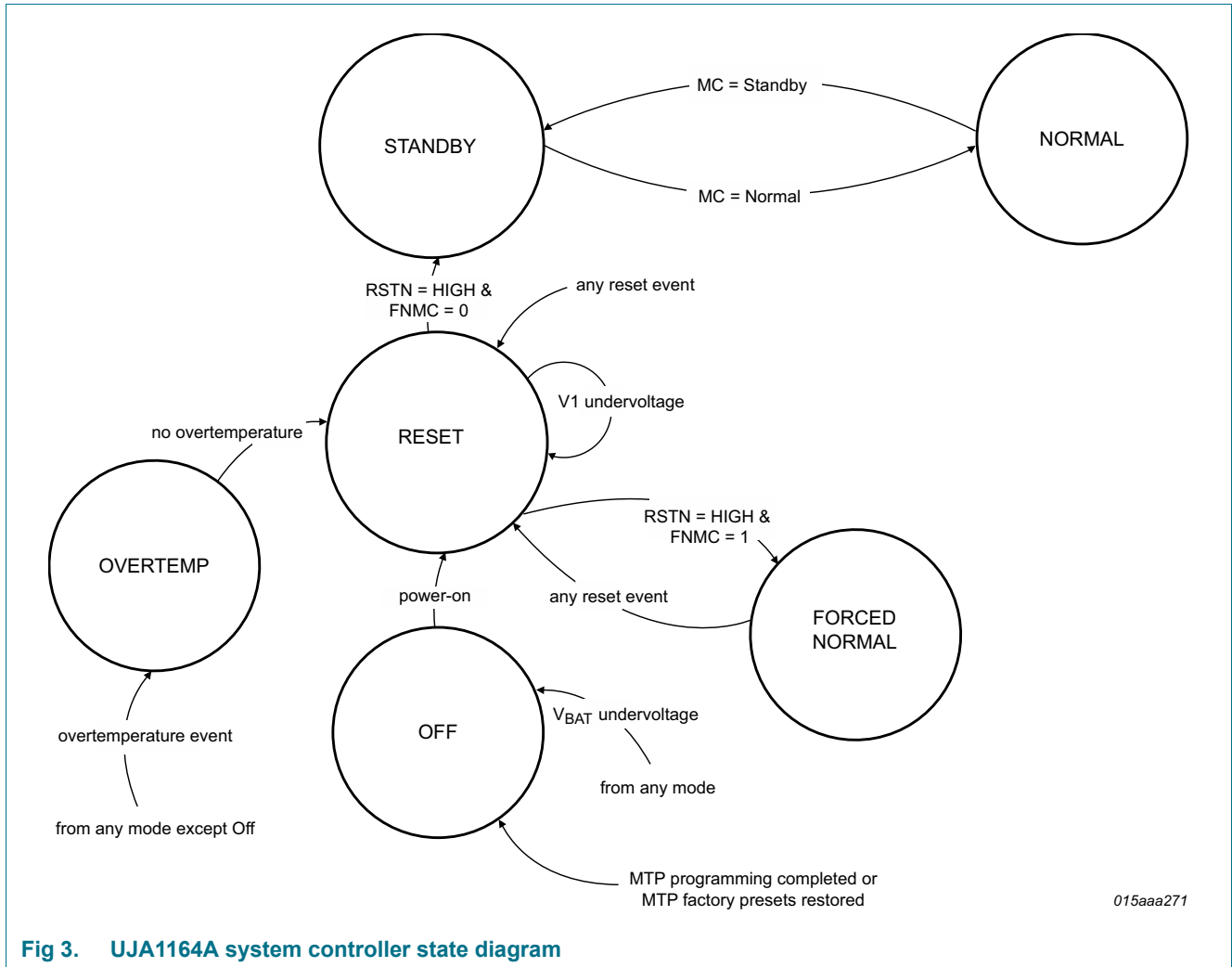

Fig 3. UJA1164A system controller state diagram

6.1.1.3 Reset mode

Reset mode is the reset execution state of the SBC. This mode ensures that pin RSTN is pulled down for a defined time to allow the microcontroller to start up in a controlled manner.

The transceiver is unable to transmit or receive data in Reset mode. The SPI is inactive; the watchdog is disabled; V1 and overtemperature detection are active.

The UJA1164A switches to Reset mode from any mode in response to a reset event (see [Table 5](#) for a list of reset sources).

The UJA1164A exits Reset mode:

- and switches to Standby mode if pin RSTN is released HIGH
- and switches to Forced Normal mode if bit FNMC = 1
- if the SBC is forced into Off or Overtemp mode

If a V1 undervoltage event forced the transition to Reset mode, the UJA1164A will remain in Reset mode until the voltage on pin V1 has recovered.

6.1.1.4 Off mode

The UJA1164A switches to Off mode when the battery is first connected or from any mode when $V_{BAT} < V_{th(det)poff}$. Only power-on detection is enabled; all other modules are inactive. The UJA1164A starts to boot up when the battery voltage rises above the power-on detection threshold $V_{th(det)pon}$ (triggering an initialization process) and switches to Reset mode after $t_{startup}$. In Off mode, the CAN pins disengage from the bus (zero load; high-ohmic).

6.1.1.5 Overtemp mode

Overtemp mode is provided to prevent the UJA1164A being damaged by excessive temperatures. The UJA1164A switches immediately to Overtemp mode from any mode (other than Off mode) when the global chip temperature rises above the overtemperature protection activation threshold, $T_{th(act)otp}$.

To help prevent the loss of data due to overheating, the UJA1164A issues a warning when the IC temperature rises above the overtemperature warning threshold ($T_{th(warn)otp}$). When this happens, status bit OTWS is set and an overtemperature warning event is captured (OTW = 1), if enabled (OTWE = 1).

In Overtemp mode, the CAN transmitter and receiver are disabled and the CAN pins are in a high-ohmic state. No wake-up event will be detected, but a pending wake-up will still be signalled by a LOW level on pin RXD, which will persist after the overtemperature event has been cleared. V1 is off and pin RSTN is driven LOW.

The UJA1164A exits Overtemp mode:

- and switches to Reset mode if the chip temperature falls below the overtemperature protection release threshold, $T_{th(rel)otp}$
- if the device is forced to switch to Off mode ($V_{BAT} < V_{th(det)poff}$)

6.1.1.6 Forced Normal mode

Forced Normal mode simplifies SBC testing and is useful for initial prototyping and failure detection, as well as first flashing of the microcontroller. The watchdog is disabled in Forced Normal mode. The low-drop voltage regulator (V1) and the CAN transceiver are active.

Bit FNMC is factory preset to 1, so the UJA1164A initially boots up in Forced Normal mode (see [Table 8](#)). This allows a newly installed device to be run in Normal mode without a watchdog. So the microcontroller can be flashed via the CAN bus in the knowledge that a watchdog timer overflow will not trigger a system reset.

The register containing bit FNMC (address 74h) is stored in non-volatile memory (see [Section 6.9](#)). So once bit FNMC is programmed to 0, the SBC will no longer boot up in Forced Normal mode, allowing the watchdog to be enabled.

Even in Forced Normal mode, a reset event (e.g. an external reset or a V1 undervoltage) will trigger a transition to Reset mode with normal Reset mode behavior (except that the transmitter remains active if there is no V1 undervoltage). However, the UJA1164A will return to Forced Normal mode instead of switching to Standby mode when it exits Reset mode.

In Forced Normal mode, only the Main status register, the Watchdog status register, the Identification register and registers stored in non-volatile memory can be read. The non-volatile memory area is fully accessible for writing as long as the UJA1164A is in the factory preset state (for details see [Section 6.9](#)).

The UJA1164A switches from Reset mode to Forced Normal mode if bit FNMC = 1.

6.1.1.7 Hardware characterization for the UJA1164A operating modes

Table 3. Hardware characterization by functional block

Block	Operating mode					
	Off	Forced Normal	Standby	Normal	Reset	Overtemp
V1	off ^[1]	on	on	on	on	off
RSTN	LOW	HIGH	HIGH	HIGH	LOW	LOW
SPI	disabled	active	active	active	disabled	disabled
Watchdog	off	off	determined by bits WMC (see Table 7) ^[2]	determined by bits WMC ^[2]	off	off
CAN	off	Active	Offline	Active/ Offline/ Listen-only (determined by bits CMC; see Table 14)	Offline	off
RXD	V1 level	CAN bit stream	V1 level/LOW if wake-up detected	CAN bit stream if CMC = 01/10/11; otherwise same as Standby	V1 level/LOW if wake-up detected	V1 level/LOW if wake-up detected

[1] When the SBC switches from Reset, Standby or Normal mode to Off mode, V1 behaves as a current source during power down while V_{BAT} is between 3 V and 2 V.

[2] Window mode is only active in Normal mode.

6.1.2 System control registers

The operating mode is selected via bits MC in the Mode control register. The Mode control register is accessed via SPI address 0x01 (see [Section 6.13](#)).

Table 4. Mode control register (address 01h)

Bit	Symbol	Access	Value	Description
7:3	reserved	R	-	
2:0	MC	R/W		mode control:
			100	Standby mode
			111	Normal mode

The Main status register can be accessed to monitor the status of the overtemperature warning flag and to determine whether the UJA1164A has entered Normal mode after initial power-up. It also indicates the source of the most recent reset event.

Table 5. Main status register (address 03h)

Bit	Symbol	Access	Value	Description
7	reserved	R	-	
6	OTWS	R		overtemperature warning status:
			0	IC temperature below overtemperature warning threshold
			1	IC temperature above overtemperature warning threshold

Table 5. Main status register (address 03h) ...continued

Bit	Symbol	Access	Value	Description
5	NMS	R		Normal mode status:
			0	UJA1164A has entered Normal mode (after power-up)
			1	UJA1164A has powered up but has not yet switched to Normal mode
4:0	RSS	R		reset source status:
			00000	exited Off mode (power-on)
			01110	watchdog triggered too early (Window mode)
			01111	watchdog overflow (Window mode or Timeout mode with WDF = 1)
			10000	illegal watchdog mode control access
			10001	RSTN pulled down externally
			10010	exited Overtemp mode
			10011	V1 undervoltage

6.2 Watchdog

The UJA1164A contains a watchdog that supports three operating modes: Window, Timeout and Autonomous. In Window mode (available only in SBC Normal mode), a watchdog trigger event within a closed watchdog window resets the watchdog timer. In Timeout mode, the watchdog runs continuously and can be reset at any time within the timeout time by a watchdog trigger. Watchdog timeout mode can also be used for cyclic wake-up of the microcontroller. In Autonomous mode, the watchdog can be off or in Timeout mode (see [Section 6.2.4](#)).

The watchdog mode is selected via bits WMC in the Watchdog control register ([Table 7](#)). The SBC must be in Standby mode when the watchdog mode and/or period is changed. If Window mode is selected (WMC = 100), the watchdog will remain in (or switch to) Timeout mode until the SBC enters Normal mode. Any attempt to change the watchdog operating mode (via WMC) or period (via NWP) while the SBC is in Normal mode will cause the UJA1164A to switch to Reset mode. The reset source status bits (RSS) will be set to 10000 ('illegal watchdog mode control access'; see [Table 5](#)) and an SPI failure (SPIF) event triggered, if enabled.

Eight watchdog periods are supported, from 8 ms to 4096 ms. The watchdog period is programmed via bits NWP. The selected period is valid for both Window and Timeout modes. The default watchdog period is 128 ms.

A watchdog trigger event resets the watchdog timer. A watchdog trigger event is any valid write access to the Watchdog control register. If the watchdog mode or the watchdog period have changed as a result of the write access, the new values are immediately valid.

Table 6. Watchdog configuration

Operating/watchdog mode					
FNMC (Forced Normal mode control)	0	0	0	0	1
SDMC (Software Development mode control)	x	x	0	1	x
WMC (watchdog mode control)	100 (Window)	010 (Timeout)	001 (Autonomous)	001 (Autonomous)	n.a.

Table 6. Watchdog configuration

Operating/watchdog mode						
SBC Operating Mode	Normal mode	Window	Timeout	Timeout	off	off
	Standby mode (RXD HIGH) ^[1]	Timeout	Timeout	off	off	off
	Standby mode (RXD LOW) ^[1]	Timeout	Timeout	Timeout	off	off
	Sleep mode	Timeout	Timeout	off	off	off
	Other modes	off	off	off	off	off

[1] RXD LOW signals a pending wake-up.

Table 7. Watchdog control register (address 00h)

Bit	Symbol	Access	Value	Description
7:5	WMC	R/W		watchdog mode control:
			001 ^[1]	Autonomous mode
			010 ^[2]	Timeout mode
			100 ^[3]	Window mode
4	reserved	R	-	
3:0	NWP	R/W		nominal watchdog period
			1000	8 ms
			0001	16 ms
			0010	32 ms
			1011	64 ms
			0100 ^[2]	128 ms
			1101	256 ms
			1110	1024 ms
0111	4096 ms			

[1] Default value if SDMC = 1 (see [Section 6.2.1](#))

[2] Default value.

[3] Selected in Standby mode but only activated when the SBC switches to Normal mode.

The watchdog is a valuable safety mechanism, so it is critical that it is configured correctly. Two features are provided to prevent watchdog parameters being changed by mistake:

- redundant states of configuration bits WMC and NWP
- reconfiguration protection in Normal mode

Redundant states associated with control bits WMC and NWP ensure that a single bit error cannot cause the watchdog to be configured incorrectly (at least two bits must be changed to reconfigure WMC or NWP). If an attempt is made to write an invalid code to WMC or NWP (e.g. 011 or 1001 respectively), the SPI operation is abandoned and an SPI failure event is captured, if enabled (see [Section 6.8](#)).

Two operating modes have a major impact on the operation of the watchdog: Forced Normal mode and Software Development mode (Software Development mode is provided for test purposes and is not an SBC operating mode; the UJA1164A can be in any mode with Software Development mode enabled; see [Section 6.2.1](#)). These modes are enabled and disabled via bits FNMC and SDMC respectively in the SBC configuration control

register (see [Table 8](#)). Note that this register is located in the non-volatile memory area (see [Section 6.8](#)). In Forced Normal mode (FNM), the watchdog is completely disabled. In Software Development mode (SDM), the watchdog can be disabled or activated for test purposes.

Information on the status of the watchdog is available from the Watchdog status register ([Table 9](#)). This register also indicates whether Forced Normal and Software Development modes are active.

Table 8. SBC configuration control register (address 74h)

Bit	Symbol	Access	Value	Description
7:6	reserved	R	-	
5:4	V1RTSUC	R/W		V1 reset threshold (defined by bit V1RTC) at start-up:
			00 ^[1]	V1 undervoltage detection at 90 % of nominal value at start-up (V1RTC = 00)
			01	V1 undervoltage detection at 80 % of nominal value at start-up (V1RTC = 01)
			10	V1 undervoltage detection at 70 % of nominal value at start-up (V1RTC = 10)
3	FNMC	R/W		Forced Normal mode control:
			0	Forced Normal mode disabled
2	SDMC	R/W		Software Development mode control:
			0 ^[1]	Software Development mode disabled
1	reserved	R	1	Software Development mode enabled
			-	

[1] Factory preset value.

Table 9. Watchdog status register (address 05h)

Bit	Symbol	Access	Value	Description
7:4	reserved	R	-	
3	FNMS	R	0	SBC is not in Forced Normal mode
			1	SBC is in Forced Normal mode
2	SDMS	R	0	SBC is not in Software Development mode
			1	SBC is in Software Development mode
1:0	WDS	R		watchdog status:
			00	watchdog is off
			01	watchdog is in first half of window
			10	watchdog is in second half of window
			11	reserved

6.2.1 Software Development mode

Software Development mode is provided to simplify the software design process. When Software Development mode is enabled, the watchdog starts up in Autonomous mode (WMC = 001) and is inactive after a system reset, overriding the default value (see [Table 7](#)). The watchdog is always off in Autonomous mode if Software Development mode is enabled (SDMC = 1; see [Table 10](#)).

Software can be run without a watchdog in Software Development mode. However, it is possible to activate and deactivate the watchdog for test purposes by selecting Window or Timeout mode via bits WMC while the SBC is in Standby mode (note that Window mode will only be activated when the SBC switches to Normal mode). Software Development mode is activated via bits SDMC in non-volatile memory (see [Table 8](#)).

6.2.2 Watchdog behavior in Window mode

The watchdog runs continuously in Window mode. The watchdog will be in Window mode if WMC = 100 and the UJA1164A is in Normal mode.

In Window mode, the watchdog can only be triggered during the second half of the watchdog period. If the watchdog overflows, or is triggered in the first half of the watchdog period (before $t_{trig(wd)1}$), a system reset is performed. After the system reset, the reset source (either 'watchdog triggered too early' or 'watchdog overflow') can be read via the reset source status bits (RSS) in the Main Status register ([Table 5](#)). If the watchdog is triggered in the second half of the watchdog period (after $t_{trig(wd)1}$ but before $t_{trig(wd)2}$), the watchdog timer is restarted.

6.2.3 Watchdog behavior in Timeout mode

The watchdog runs continuously in Timeout mode. The watchdog will be in Timeout mode if WMC = 010 and the UJA1164A is in Normal or Standby mode. The watchdog will also be in Timeout mode if WMC = 100 and the UJA1164A is in Standby mode. If Autonomous mode is selected (WMC = 001), the watchdog will be in Timeout mode if one of the conditions for Timeout mode listed in [Table 10](#) has been satisfied.

In Timeout mode, the watchdog timer can be reset at any time by a watchdog trigger. If the watchdog overflows, a watchdog failure event (WDF) is captured. If a WDF is already pending when the watchdog overflows, a system reset is performed. In Timeout mode, the watchdog can be used as a cyclic wake-up source for the microcontroller when the UJA1164A is in Standby mode.

6.2.4 Watchdog behavior in Autonomous mode

Autonomous mode is selected when WMC = 001. In Autonomous mode, the watchdog is either off or in Timeout mode, according to the conditions detailed in [Table 10](#).

Table 10. Watchdog status in Autonomous mode

UJA1164A operating mode	Watchdog status	
	SDMC = 0	SDMC = 1
Normal	Timeout mode	off
Standby; RXD HIGH	off	off
any other mode	off	off
Standby; RXD LOW	Timeout mode	off

When Autonomous mode is selected, the watchdog will be in Timeout mode if the SBC is in Normal mode or Standby mode with RXD LOW, provided Software Development mode has been disabled (SDMC = 0). Otherwise the watchdog will be off.

In Autonomous mode, the watchdog will not be running when the SBC is in Standby mode (RXD HIGH). If a wake-up event is captured, pin RXD is forced LOW to signal the event and the watchdog is automatically restarted in Timeout mode.

6.3 System reset

When a system reset occurs, the SBC switches to Reset mode and initiates a process that generates a low-level pulse on pin RSTN.

6.3.1 Characteristics of pin RSTN

Pin RSTN is a bidirectional open drain low side driver with integrated pull-up resistance, as shown in [Figure 4](#). With this configuration, the SBC can detect the pin being pulled down externally, e.g. by the microcontroller. The input reset pulse width must be at least $t_{w(rst)}$.

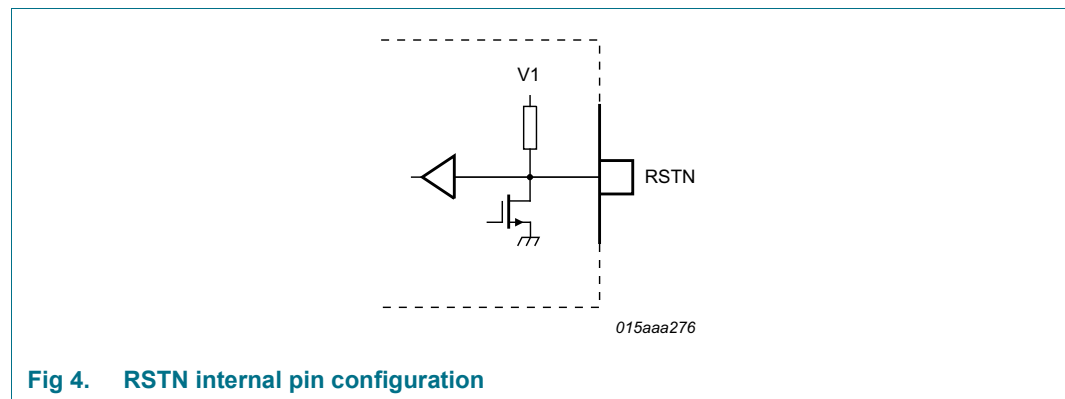

Fig 4. RSTN internal pin configuration

6.3.2 Selecting the output reset pulse width

The duration of the output reset pulse is selected via bits RLC in the Start-up control register ([Table 11](#)). The SBC distinguishes between a cold start and a warm start. A cold start is performed if the reset event was combined with a V1 undervoltage event (power-on reset, overtemperature reset, V1 undervoltage before entering or while in Reset mode). The output reset pulse width for a cold start is determined by the setting of bits RLC.

If any other reset event occurs without a V1 undervoltage (external reset, watchdog failure, watchdog change attempt in Normal mode) the SBC uses the shortest reset length ($t_{w(rst)} = 1 \text{ ms to } 1.5 \text{ ms}$). This is called warm start of the microcontroller.

Table 11. Start-up control register (address 73h)

Bit	Symbol	Access	Value	Description
7:6	reserved	R	-	

Table 11. Start-up control register (address 73h) ...continued

Bit	Symbol	Access	Value	Description
5:4	RLC	R/W		RSTN output reset pulse width:
			00 ^[1]	$t_{w(\text{rst})} = 20 \text{ ms to } 25 \text{ ms}$
			01	$t_{w(\text{rst})} = 10 \text{ ms to } 12.5 \text{ ms}$
			10	$t_{w(\text{rst})} = 3.6 \text{ ms to } 5 \text{ ms}$
			11	$t_{w(\text{rst})} = 1 \text{ ms to } 1.5 \text{ ms}$
3:0	reserved	R	-	

[1] Factory preset value.

6.3.3 Reset sources

The following events will cause the UJA1164A to switch to Reset mode:

- V_{V1} drops below the selected V1 undervoltage threshold defined by bits V1RTC
- pin RSTN is pulled down externally
- the watchdog overflows in Window mode
- the watchdog is triggered too early in Window mode (before $t_{\text{trig}(\text{wd})1}$)
- the watchdog overflows in Timeout mode with WDF = 1 (watchdog failure pending)
- an attempt is made to reconfigure the Watchdog control register while the SBC is in Normal mode
- the SBC leaves Off or Overtemp mode

6.4 Global temperature protection

The temperature of the UJA1164A is monitored continuously, except in Off mode. The SBC switches to Overtemp mode if the temperature exceeds the overtemperature protection activation threshold, $T_{\text{th}(\text{act})\text{otp}}$. In addition, pin RSTN is driven LOW and V1 and the CAN transceiver are switched off. When the temperature drops below the overtemperature protection release threshold, $T_{\text{th}(\text{rel})\text{otp}}$, the SBC switches to Standby mode via Reset mode.

In addition, the UJA1164A provides an overtemperature warning. When the IC temperature rises about the overtemperature warning threshold ($T_{\text{th}(\text{warn})\text{otp}}$), status bit OTWS is set and an overtemperature warning event is captured (OTW = 1).

6.5 Power supplies

6.5.1 Battery supply voltage (V_{BAT})

The internal circuitry is supplied from the battery via pin BAT. The device needs to be protected against negative supply voltages, e.g. by using an external series diode. If V_{BAT} falls below the power-off detection threshold, $V_{\text{th}(\text{det})\text{poff}}$, the SBC switches to Off mode. However, the microcontroller supply voltage (V1) remains active until V_{BAT} falls below 2 V.

The SBC switches from Off mode to Reset mode t_{startup} after the battery voltage rises above the power-on detection threshold, $V_{\text{th}(\text{det})\text{pon}}$. Power-on event status bit PO is set to 1 to indicate the UJA1164A has powered up and left Off mode (see [Table 19](#)).

6.5.2 Low-drop voltage supply for 5 V microcontroller (V1)

V1 is intended to supply the microcontroller and the internal CAN transceiver and delivers up to 150 mA at 5 V. The output voltage on V1 is monitored. A system reset is generated if the voltage on V1 drops below the selected undervoltage threshold (60 %, 70 %, 80 % or 90 % of the nominal V1 output voltage, selected via V1RTC in the V1 control register; see [Table 12](#)).

The internal CAN transceiver consumes 50 mA (max) when the bus is continuously dominant, leaving 100 mA available for the external load on pin V1. In practice, the typical current consumption of the CAN transceiver is lower (≈ 25 mA), depending on the application, leaving more current available for the load.

The default value of the undervoltage threshold at power-up is determined by the value of bits V1RTSUC in the SBC configuration control register ([Table 8](#)). The SBC configuration control register is in non-volatile memory, allowing the user to define the undervoltage threshold (V1RTC) at start-up.

In addition, an undervoltage warning (a V1U event; see [Section 6.8](#)) is generated if the voltage on V1 falls below 90 % of the nominal value (and V1U event detection is enabled, V1UE = 1; see [Table 23](#)). This information can be used as a warning, when the 60 %, 70 % or 80 % threshold is selected, to indicate that the level on V1 is outside the nominal supply range. The status of V1, whether it is above or below the 90 % undervoltage threshold, can be read via bit V1S in the Supply voltage status register ([Table 13](#)).

Table 12. V1 control register (address 10h)

Bit	Symbol	Access	Value	Description
7:2	reserved	R	-	
1:0	V1RTC ^[1]	R/W		set V1 reset threshold:
			00	reset threshold set to 90 % of V1 nominal output voltage
			01	reset threshold set to 80 % of V1 nominal output voltage
			10	reset threshold set to 70 % of V1 nominal output voltage
			11	reset threshold set to 60 % of V1 nominal output voltage

[1] Default value at power-up defined by setting of bits V1RTSUC (see [Table 8](#)).

Table 13. Supply voltage status register (address 1Bh)

Bit	Symbol	Access	Value	Description
7:1	reserved	R	-	
0	V1S	R/W		V1 status:
			0 ^[1]	V1 output voltage above 90 % undervoltage threshold
			1	V1 output voltage below 90 % undervoltage threshold

[1] Default value at power-up.

6.6 High-speed CAN transceiver

The integrated high-speed CAN transceiver is designed for active communication at bit rates up to 1 Mbit/s, providing differential transmit and receive capability to a CAN protocol controller. The transceiver is ISO 11898-2:2016 compliant. The CAN transmitter is

supplied from V1. The UJA1164A includes additional timing parameters on loop delay symmetry to ensure reliable communication in fast phase at data rates up to 5 Mbit/s, as used in CAN FD networks.

The CAN transceiver supports autonomous CAN biasing, which helps to minimize RF emissions. CANH and CANL are always biased to 2.5 V when the transceiver is in Active or Listen-only modes (CMC = 01/10/11).

Autonomous biasing is active in CAN Offline mode - to 2.5 V if there is activity on the bus (CAN Offline Bias mode) and to GND if there is no activity on the bus for $t > t_{to(silence)}$ (CAN Offline mode).

This is useful when the node is disabled due to a malfunction in the microcontroller. The SBC ensures that the CAN bus is correctly biased to avoid disturbing ongoing communication between other nodes. The autonomous CAN bias voltage is derived directly from V_{BAT} .

6.6.1 CAN operating modes

The integrated CAN transceiver supports four operating modes: Active, Listen-only, Offline and Offline Bias (see [Figure 5](#)). The CAN transceiver operating mode depends on the UJA1164A operating mode and on the setting of bits CMC in the CAN control register ([Table 14](#)).

When the UJA1164A is in Normal mode, the CAN transceiver operating mode (Active, Listen-only or Offline) can be selected via bits CMC in the CAN control register ([Table 14](#)). When the UJA1164A is in Standby mode, the transceiver is forced to Offline or Offline Bias mode (depending on bus activity).

6.6.1.1 CAN Active mode

In CAN Active mode, the transceiver can transmit and receive data via CANH and CANL. The differential receiver converts the analog data on the bus lines into digital data, which is output on pin RXD. The transmitter converts digital data generated by the CAN controller (input on pin TXD) into analog signals suitable for transmission over the CANH and CANL bus lines.

CAN Active mode is selected when CMC = 01 or 10. When CMC = 01, V1/CAN undervoltage detection is enabled and the transceiver will go to CAN Offline or CAN Offline Bias mode when the voltage on V1 drops below the 90 % threshold. When CMC = 10, V1/CAN undervoltage detection is disabled. The transmitter will remain active until the voltage on V1 drops below the V1 reset threshold (selected via bits V1RTC). The SBC will then switch to Reset mode and the transceiver will switch to CAN Offline or CAN Offline Bias mode.

The CAN transceiver is in Active mode when:

- the UJA1164A is in Normal mode (MC = 111) and the CAN transceiver has been enabled by setting bits CMC in the CAN control register to 01 or 10 (see [Table 14](#)) and:
 - if CMC = 01, the voltage on pin V1 is above the 90 % undervoltage threshold
 - if CMC = 10, the voltage on pin V1 is above the V1 reset threshold

If pin TXD is held LOW (e.g. by a short-circuit to GND) when CAN Active mode is selected via bits CMC, the transceiver will not enter CAN Active mode but will switch to or remain in CAN Listen-only mode. It will remain in Listen-only mode until pin TXD goes HIGH in order to prevent a hardware and/or software application failure from driving the bus lines to an unwanted dominant state.

In CAN Active mode, the CAN bias voltage is derived from V1.

The application can determine whether the CAN transceiver is ready to transmit/receive data or is disabled by reading the CAN Transceiver Status (CTS) bit in the Transceiver Status Register ([Table 15](#)).

6.6.1.2 CAN Listen-only mode

CAN Listen-only mode allows the UJA1164A to monitor bus activity while the transceiver is inactive, without influencing bus levels. This facility could be used by development tools that need to listen to the bus but do not need to transmit or receive data or for software-driven selective wake-up. Dedicated microcontrollers could be used for selective wake-up, providing an embedded low-power CAN engine designed to monitor the bus for potential wake-up events.

In Listen-only mode the CAN transmitter is disabled, reducing current consumption. The CAN receiver and CAN biasing remain active. This enables the host microcontroller to switch to a low-power mode in which an embedded CAN protocol controller remains active, waiting for a signal to wake up the microcontroller.

The CAN transceiver is in Listen-only mode when:

- the UJA1164A is in Normal mode and CMC = 11

The CAN transceiver will not leave Listen-only mode while TXD is LOW or CAN Active mode is selected with CMC = 01 while the voltage on V1 is below the 90 % undervoltage threshold.

6.6.1.3 CAN Offline and Offline Bias modes

In CAN Offline mode, the transceiver monitors the CAN bus for a wake-up event, provided CAN wake-up detection is enabled (CWE = 1). CANH and CANL are biased to GND.

CAN Offline Bias mode is the same as CAN Offline mode, with the exception that the CAN bus is biased to 2.5 V. This mode is activated automatically when activity is detected on the CAN bus while the transceiver is in CAN Offline mode. The transceiver will return to CAN Offline mode if the CAN bus is silent (no CAN bus edges) for longer than $t_{to(silence)}$.

The CAN transceiver switches to CAN Offline mode from CAN Active mode or CAN Listen-only mode if:

- the SBC switches to Reset or Standby mode OR
- the SBC is in Normal mode and CMC = 00

provided the CAN-bus has been inactive for at least $t_{to(silence)}$. If the CAN-bus has been inactive for less than $t_{to(silence)}$, the CAN transceiver switches first to CAN Offline Bias mode and then to CAN Offline mode once the bus has been silent for $t_{to(silence)}$.

The CAN transceiver switches to CAN Offline/Offline Bias mode from CAN Active mode if CMC = 01 and the voltage on V1 drops below the 90 % undervoltage threshold or CMC = 10 and the voltage on V1 drops below the V1 reset threshold.

The CAN transceiver switches to CAN Offline mode:

- from CAN Offline Bias mode if no activity is detected on the bus (no CAN edges) for $t > t_{\text{to(silence)}}$ OR
- when the SBC switches from Off or Overtemp mode to Reset mode

The CAN transceiver switches from CAN Offline mode to CAN Offline Bias mode if:

- a standard wake-up pattern is detected on the CAN bus OR
- the SBC is in Normal mode, CMC = 01 or 10 and $V_{V1} < 90\%$

6.6.1.4 CAN Off mode

The CAN transceiver is switched off completely with the bus lines floating when:

- the SBC switches to Off or Overtemp mode OR
- V_{BAT} falls below the CAN receiver undervoltage detection threshold, $V_{\text{uvd(CAN)}}$

It will be switched on again on entering CAN Offline mode when V_{BAT} rises above the undervoltage recovery threshold ($V_{\text{uvr(CAN)}}$) and the SBC is no longer in Off/Overtemp mode. CAN Off mode prevents reverse currents flowing from the bus when the battery supply to the SBC is lost.

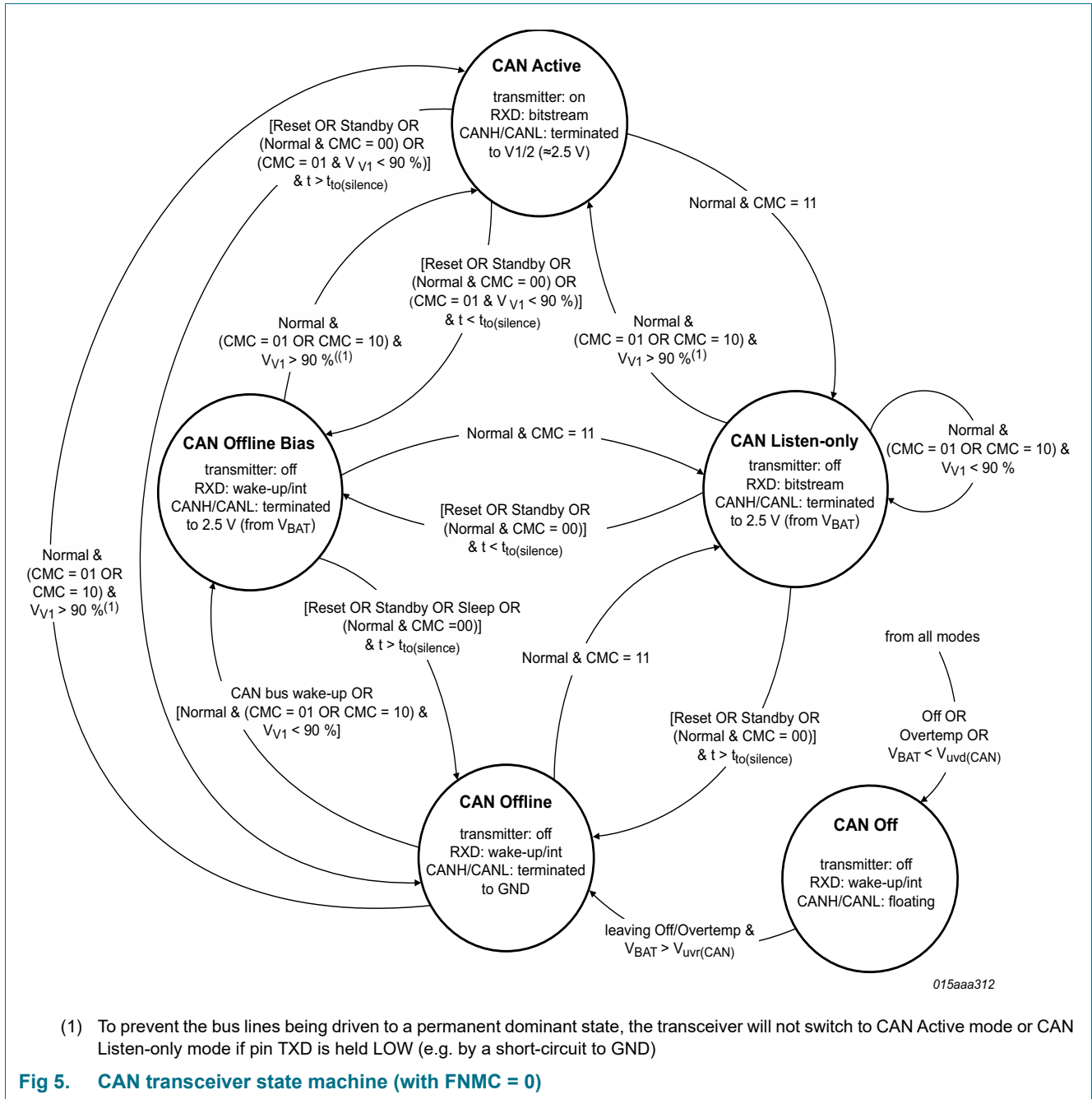

6.6.2 CAN standard wake-up

If the CAN transceiver is in Offline mode and CAN wake-up is enabled ($CWE = 1$), the UJA1164A will monitor the bus for a wake-up pattern.

A filter at the receiver input prevents unwanted wake-up events occurring due to automotive transients or EMI. A dominant-recessive-dominant wake-up pattern must be transmitted on the CAN bus within the wake-up timeout time ($t_{to(wake)}$) to pass the wake-up filter and trigger a wake-up event (see Figure 6; note that additional pulses may occur between the recessive/dominant phases). The recessive and dominant phases must last at least $t_{wake(busrec)}$ and $t_{wake(busdom)}$, respectively.

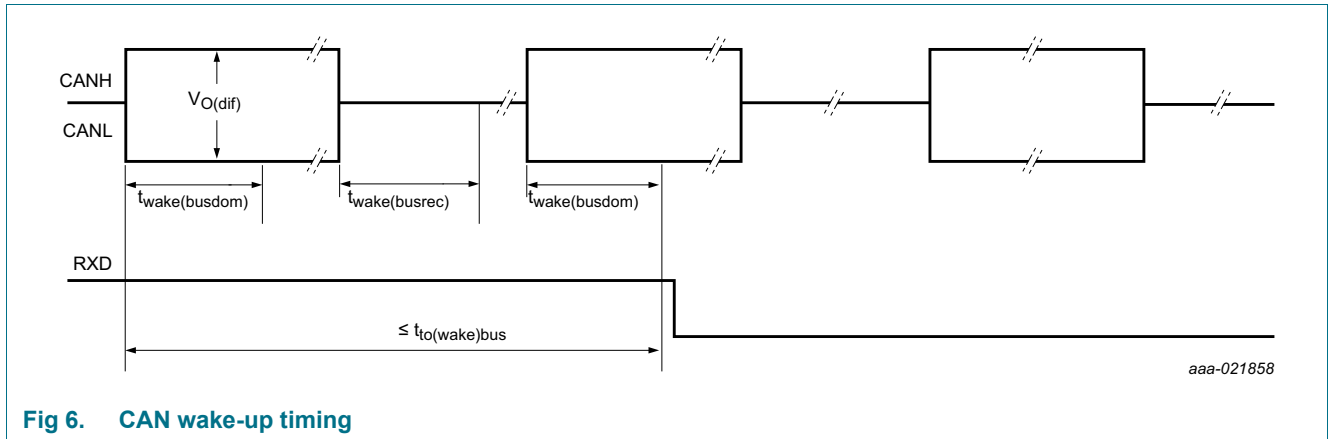

Fig 6. CAN wake-up timing

When a valid CAN wake-up pattern is detected on the bus, wake-up bit CW in the Transceiver event status register is set (see [Table 21](#)) and pin RXD is driven LOW.

6.6.3 CAN control and Transceiver status registers

Table 14. CAN control register (address 20h)

Bit	Symbol	Access	Value	Description
7:2	reserved	R/W	-	
1:0	CMC	R/W		CAN transceiver operating mode selection (available when UJA1164A is in Normal mode; MC = 111):
			00	Offline mode
			01	Active mode; see Section 6.6.1.1 and Section 6.6.1.3
			10	Active mode; see Section 6.6.1.1 and Section 6.6.1.3
	11	Listen-only mode		

Table 15. Transceiver status register (address 22h)

Bit	Symbol	Access	Value	Description
7	CTS	R	0	CAN transceiver not in Active mode
			1	CAN transceiver in Active mode
6:4	reserved	R	-	
3	CBSS	R	0	CAN bus active (communication detected on bus)
			1	CAN bus inactive (for longer than $t_{to(silence)}$)
2	reserved	R	-	
1	VCS ^[1]	R	0	the output voltage on V1 is above the 90 % threshold
			1	the output voltage on V1 is below the 90 % threshold
0	CFS	R	0	no TXD dominant timeout event detected
			1	CAN transmitter disabled due to a TXD dominant timeout event

[1] Only active when CMC = 01.

6.7 CAN fail-safe features

6.7.1 TXD dominant timeout

A TXD dominant time-out timer is started when pin TXD is forced LOW while the transceiver is in CAN Active Mode. If the LOW state on pin TXD persists for longer than the TXD dominant time-out time ($t_{to(dom)TXD}$), the transmitter is disabled, releasing the bus lines to recessive state. This function prevents a hardware and/or software application failure from driving the bus lines to a permanent dominant state (blocking all network communications). The TXD dominant time-out timer is reset when pin TXD goes HIGH. The TXD dominant time-out time also defines the minimum possible bit rate of 4.4 kbit/s.

When the TXD dominant time-out time is exceeded, a CAN failure event is captured (CF = 1; see [Table 21](#)), if enabled (CFE = 1; see [Table 24](#)). In addition, the status of the TXD dominant timeout can be read via the CFS bit in the Transceiver status register ([Table 15](#)) and bit CTS is cleared.

6.7.2 Pull-up on TXD pin

Pin TXD has an internal pull-up towards V1 to ensure a safe defined recessive driver state in case the pin is left floating.

6.7.3 V1 undervoltage event

When CMC = 01, a CAN failure event is captured (CF = 1) and status bit VCS is set to 1 when the supply to the CAN transceiver (V_{V1}) falls below 90 % of its nominal value (assuming CAN failure detection is enabled; CFE = 1).

6.7.4 Loss of power at pin BAT

A loss of power at pin BAT has no influence on the bus lines or on the microcontroller. No reverse currents will flow from the bus.

6.8 Wake-up and interrupt event diagnosis via pin RXD

Wake-up and interrupt event diagnosis in the UJA1164A is intended to provide the microcontroller with information on the status of a range of features and functions. This information is stored in the event status registers ([Table 19](#) to [Table 21](#)) and is signaled on pin RXD, if enabled.

A distinction is made between regular CAN wake-up events and interrupt events.

Table 16. Regular events

Symbol	Event	Power-on	Description
CW	CAN wake-up	disabled	a CAN wake-up event was detected while the transceiver was in CAN Offline mode.

Table 17. Diagnostic/interrupt events

Symbol	Event	Power-on	Description
PO	power-on	always enabled	the UJA1164A has exited Off mode (after battery power has been restored/connected)
OTW	overtemperature warning	disabled	the IC temperature has exceeded the overtemperature warning threshold
SPIF	SPI failure	disabled	SPI clock count error (only 16-, 24- and 32-bit commands are valid), illegal WMC, NWP or MC code or attempted write access to locked register
WDF	watchdog failure	always enabled	watchdog overflow in Window or Timeout mode or watchdog triggered too early in Window mode; a system reset is triggered immediately in response to a watchdog failure in Window mode; when the watchdog overflows in Timeout mode, a system reset is only performed if a WDF is already pending (WDF = 1)
V1U	V1 undervoltage	disabled	voltage on V1 has dropped below the 90 % undervoltage threshold when V1 is active. V1U event capture is independent of the setting of bits V1RTC.
CBS	CAN bus silence	disabled	no activity on CAN bus for $t_{to(silence)}$ (detected only when CBSE = 1 while bus active)
CF	CAN failure	disabled	one of the following CAN failure events detected: <ul style="list-style-type: none"> - CAN transceiver deactivated due to a V1 undervoltage - CAN transceiver deactivated due to a dominant clamped TXD.

PO and WDF interrupts are always captured. Wake-up and interrupt detection can be enabled/disabled for the remaining events individually via the event capture enable registers (Table 22 to Table 24).

If an event occurs while the associated event capture function is enabled, the relevant event status bit is set. If the transceiver is in CAN Offline mode with V1 active (SBC Normal or Standby mode), pin RXD is forced LOW to indicate that a wake-up or interrupt event has been detected.

The microcontroller can monitor events via the event status registers. An extra status register, the Global event status register (Table 18), is provided to help speed up software polling routines. By polling the Global event status register, the microcontroller can quickly determine the type of event captured (system, supply or transceiver) and then query the relevant table (Table 19, Table 20 or Table 21 respectively).

After the event source has been identified, the status flag should be cleared (set to 0) by writing 1 to the relevant bit (writing 0 will have no effect). A number of status bits can be cleared in a single write operation by writing 1 to all relevant bits.

It is strongly recommended to clear only the status bits that were set to 1 when the status registers were last read. This precaution ensures that events triggered just before the write access are not lost.

6.8.1 Interrupt/wake-up delay

If interrupt or wake-up events occur very frequently while the transceiver is in CAN Offline mode, they can have a significant impact on the software processing time (because pin RXD is repeatedly driven LOW, requiring a response from the microcontroller each time an interrupt/wake-up is generated). The UJA1164A incorporates an event delay timer to limit the disturbance to the software.

When one of the event capture status bits is cleared, pin RXD is released (HIGH) and a timer is started. If further events occur while the timer is running, the relevant status bits are set. If one or more events are pending when the timer expires after $t_{d(event)}$, pin RXD goes LOW again to alert the microcontroller.

In this way, the microcontroller is interrupted once to process a number of events rather than several times to process individual events.

If all events are cleared while the timer is running, RXD remains HIGH after the timer expires, since there are no pending events. The event capture registers can be read at any time.

The event capture delay timer is stopped immediately when pin RSTN goes low (triggered by a HIGH-to-LOW transition on the pin). RSTN is driven LOW when the SBC enters Reset, Overtemp and Off modes.

6.8.2 Event status and event capture registers

After an event source has been identified, the status flag should be cleared (set to 0) by writing 1 to the relevant status bit (writing 0 will have no effect).

Table 18. Global event status register (address 60h)

Bit	Symbol	Access	Value	Description
7:3	reserved	R	-	
2	TRXE	R	0	no pending transceiver event
			1	transceiver event pending at address 0x63
1	SUPE	R	0	no pending supply event
			1	supply event pending at address 0x62
0	SYSE	R	0	no pending system event
			1	system event pending at address 0x61

Table 19. System event status register (address 61h)

Bit	Symbol	Access	Value	Description
7:5	reserved	R	-	
4	PO	R/W	0	no recent power-on
			1	the UJA1164A has left Off mode after power-on
3	reserved	R	-	
2	OTW	R/W	0	overtemperature not detected
			1	the global chip temperature has exceeded the overtemperature warning threshold ($T_{th(warm)otp}$)
1	SPIF	R/W	0	no SPI failure detected
			1	SPI failure detected
0	WDF	R/W	0	no watchdog failure event captured
			1	watchdog failure event captured

Table 20. Supply event status register (address 62h)

Bit	Symbol	Access	Value	Description
7:1	reserved	R	-	
0	V1U	R/W	0	no V1 undervoltage event captured
			1	V1 undervoltage event captured

Table 21. Transceiver event status register (address 63h)

Bit	Symbol	Access	Value	Description
7:5	reserved	R	-	
4	CBS	R/W	0	CAN bus active
			1	no activity on CAN bus for $t_{to(silence)}$
3:2	reserved	R	-	
1	CF	R/W	0	no CAN failure detected
			1	(CMC = 01 & CAN transceiver deactivated due to V1 undervoltage) OR dominant clamped TXD
0	CW	R/W	0	no CAN wake-up event detected
			1	CAN wake-up event detected while the transceiver is in CAN Offline Mode

Table 22. System event capture enable register (address 04h)

Bit	Symbol	Access	Value	Description
7:3	reserved	R	-	
2	OTWE	R/W		overtemperature warning event capture:
			0	overtemperature warning disabled
			1	overtemperature warning enabled
1	SPIFE	R/W		SPI failure detection:
			0	SPI failure detection disabled
			1	SPI failure detection enabled
0	reserved	R	-	

Table 23. Supply event capture enable register (address 1Ch)

Bit	Symbol	Access	Value	Description
7:1	reserved	R	-	
0	V1UE	R/W		V1 undervoltage detection:
			0	V1 undervoltage detection disabled
			1	V1 undervoltage detection enabled

Table 24. Transceiver event capture enable register (address 23h)

Bit	Symbol	Access	Value	Description
7:5	reserved	R	-	
4	CBSE	R/W		CAN bus silence detection:
			0	CAN bus silence detection disabled
			1	CAN bus silence detection enabled
3:2	reserved	R	-	

Table 24. Transceiver event capture enable register (address 23h)

Bit	Symbol	Access	Value	Description
1	CFE	R/W		CAN failure detection
			0	CAN failure detection disabled
			1	CAN failure detection enabled
0	CWE	R/W		CAN wake-up detection:
			0	CAN wake-up detection disabled
			1	CAN wake-up detection enabled

6.9 Non-volatile SBC configuration

The UJA1164A contains Multiple Time Programmable Non-Volatile (MTPNV) memory cells that allow some of the default device settings to be reconfigured. The MTPNV memory address range is from 0x73 to 0x74. An overview of the MTPNV registers is given in [Table 25](#).

Table 25. Overview of MTPNV registers

Address	Register Name	Bit:							
		7	6	5	4	3	2	1	0
0x73	Start-up control (see Table 11)	reserved		RLC		reserved			
0x74	SBC configuration control (see Table 8)	reserved		V1RTSUC		FNMC	SDMC	reserved	

6.9.1 Programming MTPNV cells

The UJA1164A must be in Forced Normal mode and the MTPNV cells must contain the factory preset values before the non-volatile memory can be reprogrammed. The UJA1164A will switch to Forced Normal mode after a reset event (e.g. pin RSTN LOW) when the MTPNV cells contain the factory preset values (since FNMC = 1).

The factory presets may need to be restored before reprogramming can begin (see [Section 6.9.2](#)). When the factory presets have been restored, a system reset is generated automatically and UJA1164A switches to Forced Normal mode. This ensures that the programming cycle cannot be interrupted by the watchdog.

Programming of the non-volatile memory registers is performed in two steps. Firstly, the required values are written to addresses 0x73 and 0x74. In the second step, reprogramming is confirmed by writing the correct CRC value to the MTPNV CRC control register (see [Section 6.9.1.1](#)). The SBC starts reprogramming the MTPNV cells as soon as the CRC value has been validated. If the CRC value is not correct, reprogramming is aborted. On completion, a system reset is generated to indicate that the MTPNV cells have been reprogrammed successfully. Note that the MTPNV cells cannot be read while they are being reprogrammed.

After an MTPNV programming cycle has been completed, the non-volatile memory is protected from being overwritten via a standard SPI write operation.

The MTPNV cells can be reprogrammed a maximum of 200 times ($N_{cy(W)MTP}$; see [Table 42](#)). Bit NVMP5 in the MTPNV status register ([Table 26](#)) indicates whether or not the non-volatile cells can be reprogrammed. This register also contains a write counter, WRCNTS, that is incremented each time the MTPNV cells are reprogrammed (up to a

maximum value of 111111; there is no overflow; performing a factory reset also increments the counter). This counter is provided for information purposes only; reprogramming will not be rejected when it reaches its maximum value.

An error correction code status bit, ECCS, is set to indicate that the CRC check mechanism in the SBC has detected a single bit failure in non-volatile memory. If more than one bit failure is detected, the SBC will not restart after MTPNV reprogramming. Check the ECCS flag at the end of the production cycle to verify the content of non-volatile memory. When this flag is set, it indicates a device or ECU failure.

Table 26. MTPNV status register (address 70h)

Bit	Symbol	Access	Value	Description
7:2	WRCNTS	R		write counter status:
			xxxxxx	contains the number of times the MTPNV cells were reprogrammed
1	ECCS	R/W		error correction code status:
			0	no bit failure detected in non-volatile memory
			1	bit failure detected and corrected in non-volatile memory
0	NVMP5	R/W		non-volatile memory programming status:
			0	MTPNV memory cannot be overwritten
			1 ^[1]	MTPNV memory is ready to be reprogrammed

[1] Factory preset value.

6.9.1.1 Calculating the CRC value for MTP programming

The cyclic redundancy check value stored in bits CRCC in the MTPNV CRC control register is calculated using the data written to registers 0x73 and 0x74.

Table 27. MTPNV CRC control register (address 75h)

Bit	Symbol	Access	Value	Description
7:0	CRCC	R/W	-	CRC control data

The CRC value is calculated using the data representation shown in [Figure 7](#) and the modulo-2 division with the generator polynomial: $X^8 + X^5 + X^3 + X^2 + X + 1$. The result of this operation must be bitwise inverted.

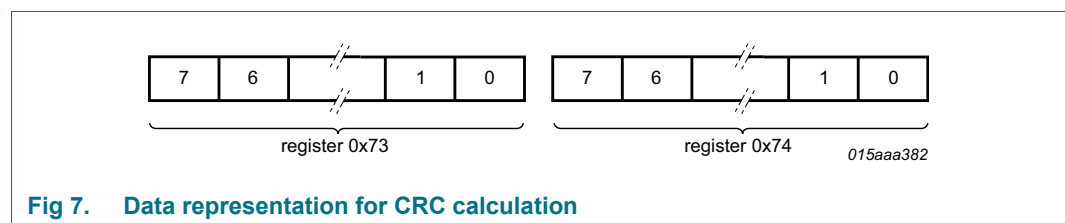

Fig 7. Data representation for CRC calculation

The following parameters can be used to calculate the CRC value (e.g. via the Autosar method):

Table 28. Parameters for CRC coding

Parameter	Value
CRC result width	8 bits
Polynomial	0x2F
Initial value	0xFF
Input data reflected	no
Result data reflected	no
XOR value	0xFF

Alternatively, the following algorithm can be used:

```

data = 0 // unsigned byte
crc = 0xFF
for i = 0 to 1
    data = content_of_address(0x73 + i) EXOR crc
    for j = 0 to 7
        if data >= 128
            data = data * 2 // shift left by 1
            data = data EXOR 0x2F
        else
            data = data * 2 // shift left by 1
    next j
    crc = data
next i
crc = crc EXOR 0xFF
    
```

6.9.2 Restoring factory preset values

Factory preset values are restored if the following conditions apply for at least $t_{d(MTPNV)}$ during power-up:

- pin RSTN is held LOW
- CANH is pulled up to V_{BAT}
- CANL is pulled down to GND

After the factory preset values have been restored, the SBC performs a system reset and enters Forced normal Mode. Since the CAN bus is clamped dominant, pin RXDC is forced LOW. During the factory preset restore process, this pin is forced HIGH; a falling edge on this pin caused by bit PO being set after power-on then clearly indicates that the process has been completed.

Note that the write counter, WRCNTS, in the MTPNV status register is incremented every time the factory presets are restored.

6.10 Device ID

A byte is reserved at address 0x7E for a UJA1164A identification code.

Table 29. Identification register (address 7Eh)

Bit	Symbol	Access	Value	Description
7:0	IDS[7:0]	R	80h	device identification code

6.11 Lock control register

Sections of the register address area can be write-protected to protect against unintended modifications. Note that this facility only protects locked bits from being modified via the SPI and will not prevent the UJA1164A updating status registers etc.

Table 30. Lock control register (address 0Ah)

Bit	Symbol	Access	Value	Description
7	reserved	R	-	cleared for future use
6	LK6C	R/W		lock control 6: address area 0x68 to 0x6F
			0	SPI write-access enabled
			1	SPI write-access disabled
5	LK5C	R/W		lock control 5: address area 0x50 to 0x5F
			0	SPI write-access enabled
			1	SPI write-access disabled
4	LK4C	R/W		lock control 4: address area 0x40 to 0x4F
			0	SPI write-access enabled
			1	SPI write-access disabled
3	LK3C	R/W		lock control 3: address area 0x30 to 0x3F
			0	SPI write-access enabled
			1	SPI write-access disabled
2	LK2C	R/W		lock control 2: address area 0x20 to 0x2F - transceiver control
			0	SPI write-access enabled
			1	SPI write-access disabled
1	LK1C	R/W		lock control 1: address area 0x10 to 0x1F - regulator control
			0	SPI write-access enabled
			1	SPI write-access disabled
0	LK0C	R/W		lock control 0: address area 0x06 to 0x09 - general purpose memory
			0	SPI write-access enabled
			1	SPI write-access disabled

6.12 General purpose memory

UJA1164A allocates 4 bytes of RAM as general purpose registers for storing user information. The general purpose registers can be accessed via the SPI at address 0x06 to 0x09 (see [Table 31](#)).

6.13 SPI

6.13.1 Introduction

The Serial Peripheral Interface (SPI) provides the communication link with the microcontroller, supporting multi-slave operations. The SPI is configured for full duplex data transfer, so status information is returned when new control data is shifted in. The interface also offers a read-only access option, allowing registers to be read back by the application without changing the register content.

The SPI uses four interface signals for synchronization and data transfer:

- SCSN: SPI chip select; active LOW
- SCK: SPI clock; default level is LOW due to low-power concept (pull-down)
- SDI: SPI data input
- SDO: SPI data output; floating when pin SCSN is HIGH

Bit sampling is performed on the falling edge of the clock and data is shifted in/out on the rising edge, as illustrated in [Figure 8](#).

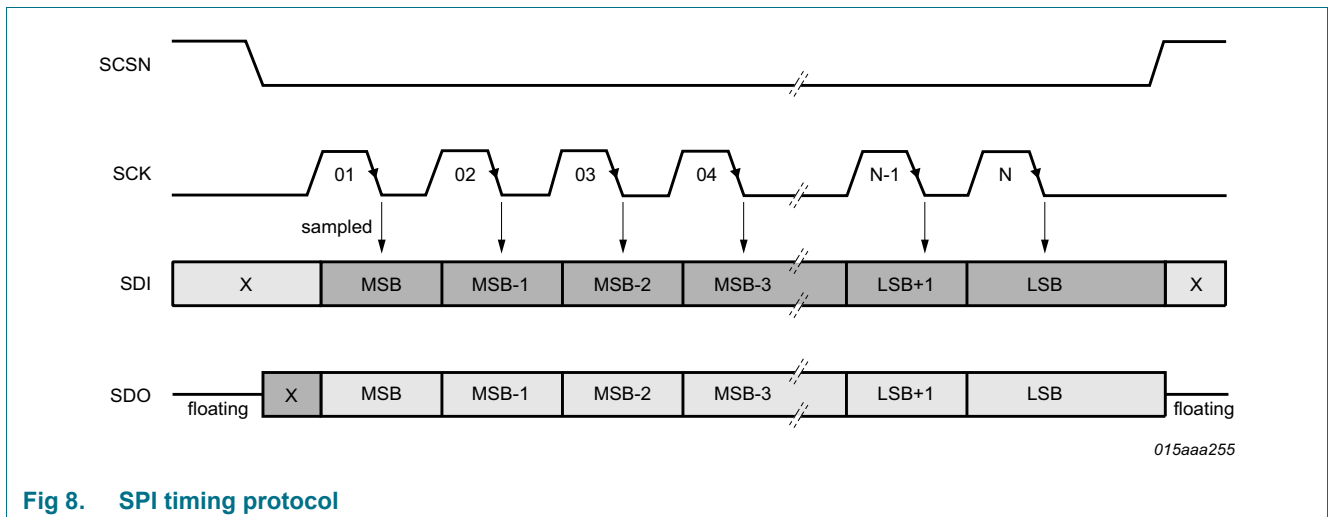

Fig 8. SPI timing protocol

The SPI data in the UJA1164A is stored in a number of dedicated 8-bit registers. Each register is assigned a unique 7-bit address. Two bytes must be transmitted to the SBC for a single register write operation. The first byte contains the 7-bit address along with a 'read-only' bit (the LSB). The read-only bit must be 0 to indicate a write operation (if this bit is 1, a read operation is assumed and any data on the SDI pin is ignored). The second byte contains the data to be written to the register.

24- and 32-bit read and write operations are also supported. The register address is automatically incremented, once for a 24-bit operation and twice for a 32-bit operation, as illustrated in [Figure 9](#).

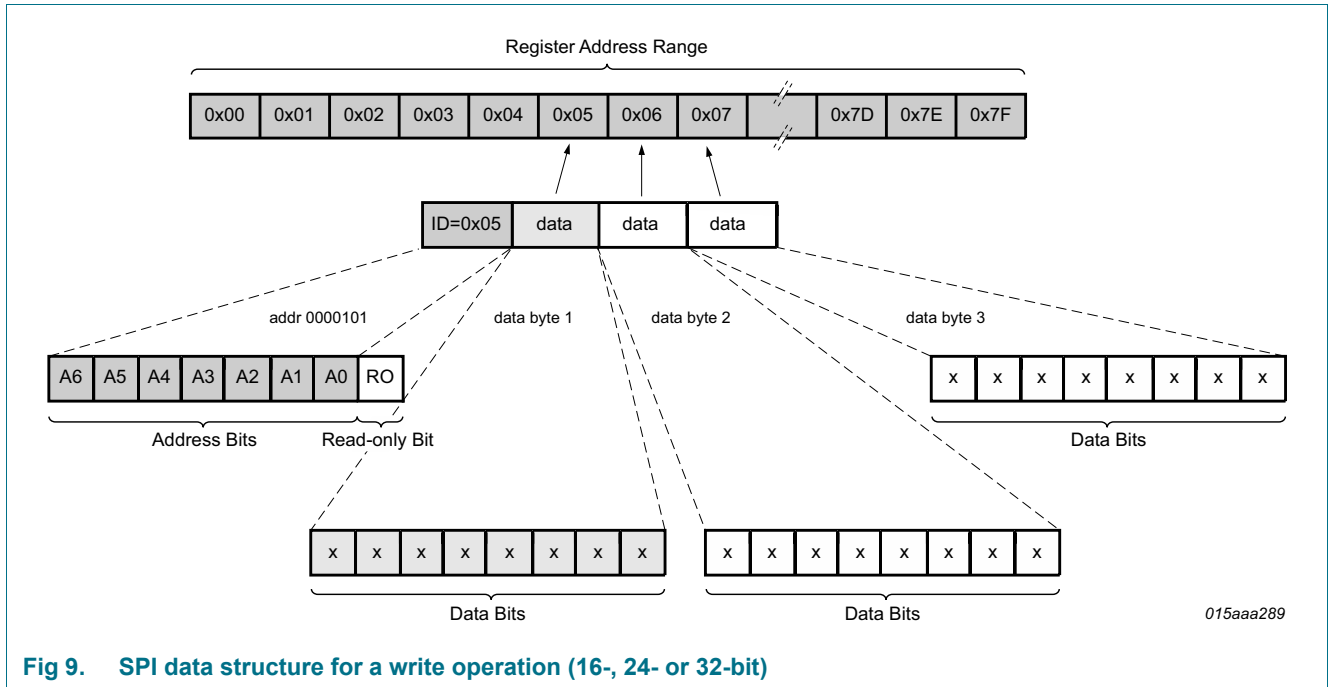

Fig 9. SPI data structure for a write operation (16-, 24- or 32-bit)

During an SPI data read or write operation, the contents of the addressed register(s) is returned via pin SDO.

The UJA1164A tolerates attempts to write to registers that don't exist. If the available address space is exceeded during a write operation, the data above the valid address range is ignored (without generating an SPI failure event).

During a write operation, the UJA1164A monitors the number of SPI bits transmitted. If the number recorded is not 16, 24 or 32, then the write operation is aborted and an SPI failure event is captured (SPIF = 1).

If more than 32 bits are clocked in on pin SDI during a read operation, the data stream on SDI is reflected on SDO from bit 33 onwards.

6.13.2 Register map

The addressable register space contains 128 registers with addresses from 0x00 to 0x7F. An overview of the register mapping is provided in [Table 31](#) to [Table 38](#). The functionality of individual bits is discussed in more detail in relevant sections of the data sheet.

Table 31. Overview of primary control registers

Address	Register Name	Bit:								
		7	6	5	4	3	2	1	0	
0x00	Watchdog control	WMC			reserved	NWP				
0x01	Mode control	reserved					MC			
0x03	Main status	reserved	OTWS	NMS	RSS					
0x04	System event enable	reserved					OTWE	SPIFE	reserved	
0x05	Watchdog status	reserved				FNMS	SDMS	WDS		
0x06	Memory 0	GPM[7:0]								
0x07	Memory 1	GPM[15:8]								
0x08	Memory 2	GPM[23:16]								
0x09	Memory 3	GPM[31:24]								
0x0A	Lock control	reserved	LK6C	LK5C	LK4C	LK3C	LK2C	LK1C	LK0C	

Table 32. Overview of V1 and transceiver control registers

Address	Register Name	Bit:								
		7	6	5	4	3	2	1	0	
0x10	V1 control	reserved							V1RTC	
0x1B	Supply status	reserved								V1S
0x1C	Supply event enable	reserved								V1UE
0x20	CAN control	reserved							CMC	
0x22	Transceiver status	CTS	reserved			CBSS	reserved	VCS	CFS	
0x23	Transceiver event enable	reserved			CBSE	reserved	CFE	CWE		

Table 33. Overview of event capture registers

Address	Register Name	Bit:								
		7	6	5	4	3	2	1	0	
0x60	Global event status	reserved					TRXE	SUPE	SYSE	
0x61	System event status	reserved			PO	reserved	OTW	SPIF	WDF	
0x62	Supply event status	reserved								V1U
0x63	Transceiver event status	reserved			CBS	reserved	CF	CW		

Table 34. Overview of MTPNV status register

Address	Register Name	Bit:							
		7	6	5	4	3	2	1	0
0x70	MTPNV status	WRCNTS						ECCS	NVMPS

Table 35. Overview of Startup control register

Address	Register Name	Bit:							
		7	6	5	4	3	2	1	0
0x73	Startup control	reserved		RLC		reserved			

Table 36. Overview of SBC configuration control register

Address	Register Name	Bit:							
		7	6	5	4	3	2	1	0
0x74	SBC configuration control	reserved		V1RTSUC		FNMC	SDMC	reserved	

Table 37. Overview of CRC control register

Address	Register Name	Bit:							
		7	6	5	4	3	2	1	0
0x75	MTPNV CRC control	CRCC[7:0]							

Table 38. Overview of Identification register

Address	Register Name	Bit:							
		7	6	5	4	3	2	1	0
0x7E	Identification	IDS[7:0]							

6.13.3 Register configuration in UJA1164A operating modes

A number of register bits may change state automatically when the UJA1164A switches from one operating mode to another. This is particularly evident when the UJA1164A switches to Off mode. These changes are summarized in [Table 39](#). If an SPI transmission is in progress when the UJA1164A changes state, the transmission is ignored (automatic state changes have priority).

Table 39. Register bit settings in UJA1164A operating modes

Symbol	Off (power-on default)	Standby	Normal	Overtemp	Reset
CBS	0	no change	no change	no change	no change
CBSE	0	no change	no change	no change	no change
CBSS	1	actual state	actual state	actual state	actual state
CF	0	no change	no change	no change	no change
CFE	0	no change	no change	no change	no change
CFS	0	actual state	actual state	actual state	actual state
CMC	00	no change	no change	no change	no change
CRCC	00000000	no change	no change	no change	no change
CTS	0	0	actual state	0	0
CW	0	no change	no change	no change	no change
CWE	0	no change	no change	no change	no change
ECCS	actual state	actual state	actual state	actual state	actual state
FNMC	MTPNV	MTPNV	MTPNV	MTPNV	MTPNV
FNMS	0	actual state	actual state	actual state	actual state
GPMn	00000000	no change	no change	no change	no change

Table 39. Register bit settings in UJA1164A operating modes ...continued

Symbol	Off (power-on default)	Standby	Normal	Overtemp	Reset
IDS	see Table 29	no change	no change	no change	no change
LKnC	0	no change	no change	no change	no change
MC	100	100	111	don't care	100
NMS	1	no change	0	no change	no change
NVMPS	actual state	actual state	actual state	actual state	actual state
NWP	0100	no change	no change	0100	0100
OTW	0	no change	no change	no change	no change
OTWE	0	no change	no change	no change	no change
OTWS	0	actual state	actual state	actual state	actual state
PO	1	no change	no change	no change	no change
RLC	MTPNV	MTPNV	MTPNV	MTPNV	MTPNV
RSS	00000	no change	no change	10010	reset source
SDMC	MTPNV	MTPNV	MTPNV	MTPNV	MTPNV
SDMS	0	actual state	actual state	actual state	actual state
SPIF	0	no change	no change	no change	no change
SPIFE	0	no change	no change	no change	no change
SUPE	0	no change	no change	no change	no change
SYSE	1	no change	no change	no change	no change
TRXE	0	no change	no change	no change	no change
V1RTC	defined by V1RTSUC	no change	no change	no change	no change
V1RTSUC	MTPNV	MTPNV	MTPNV	MTPNV	MTPNV
V1S	0	actual state	actual state	actual state	actual state
V1UE	0	no change	no change	no change	no change
V1U	0	no change	no change	no change	no change
VCS	0	actual state	actual state	actual state	actual state
WDF	0	no change	no change	no change	no change
WDS	0	actual state	actual state	actual state	actual state
WMC	[1]	no change	no change	no change	[1]
WRCNTS	actual state	actual state	actual state	actual state	actual state

[1] 001 if SDMC = 1; otherwise 010.

7. Limiting values

Table 40. Limiting values

In accordance with the Absolute Maximum Rating System (IEC 60134).

Symbol	Parameter	Conditions	Min	Max	Unit
V _x	voltage on pin x ^[1]	pin V1 ^[2]	-0.2	+6	V
		pins TXD, RXD, SDI, SDO, SCK, SCSN, RSTN ^[3]	-0.2	V _{V1} + 0.2	V
		pin BAT	-0.2	+40	V
		pins CANH and CANL with respect to any other pin	-58	+58	V
V _(CANH-CANL)	voltage between pin CANH and pin CANL		-40	+40	V
V _{trt}	transient voltage	on pins CANL, CANH, BAT ^[4]			
		pulse 1	-100	-	V
		pulse 2a	-	75	V
		pulse 3a	-150	-	V
		pulse 3b	-	100	V
V _{ESD}	electrostatic discharge voltage	IEC 61000-4-2 (150 pF, 330 Ω) discharge circuit ^[5]			
		on pins CANH and CANL; pin BAT with capacitor	-6	+6	kV
		Human Body Model (HBM)			
		on any pin ^[6]	-2	+2	kV
		on pins BAT ^[7]	-4	+4	kV
		on pins CANH, CANL ^[8]	-8	+8	kV
		Machine Model (MM) ^[9]			
		on any pin	-100	+100	V
		Charged Device Model (CDM) ^[10]			
		on corner pins	-750	+750	V
on any other pin	-500	+500	V		
T _{vj}	virtual junction temperature	^[11]	-40	+150	°C
		when programming the MTPNV cells	0	+125	°C
T _{stg}	storage temperature		-55	+150	°C

- [1] The device can sustain voltages up to the specified values over the product lifetime, provided applied voltages (including transients) never exceed these values.
- [2] When the device is not powered up, I_{V1} (max) = 25 mA.
- [3] Maximum voltage should never exceed 6 V.
- [4] Verified by an external test house according to IEC TS 62228, Section 4.2.4; parameters for standard pulses defined in ISO7637 part 2.
- [5] Verified by an external test house according to IEC TS 62228, Section 4.3.
- [6] According to AEC-Q100-002.
- [7] Pins stressed to reference group containing all grounds, emulating the application circuit (Figure 14). HBM pulse as specified in AEC-Q100-002 used.
- [8] Pins stressed to reference group containing all ground and supply pins, emulating the application circuit (Figure 14). HBM pulse as specified in AEC-Q100-002 used.
- [9] According to AEC-Q100-003.
- [10] According to AEC-Q100-011.

[11] In accordance with IEC 60747-1. An alternative definition of virtual junction temperature is: $T_{vj} = T_{amb} + P \times R_{th(j-a)}$, where $R_{th(j-a)}$ is a fixed value used in the calculation of T_{vj} . The rating for T_{vj} limits the allowable combinations of power dissipation (P) and ambient temperature (T_{amb}).

8. Thermal characteristics

Table 41. Thermal characteristics

Symbol	Parameter	Conditions	Typ	Unit
$R_{th(vj-a)}$	thermal resistance from virtual junction to ambient		[1] 60	K/W

[1] According to JEDEC JESD51-2, JESD51-5 and JESD51-7 at natural convection on 2s2p board. Board with two inner copper layers (thickness: 35 μ m) and thermal via array under the exposed pad connected to the first inner copper layer (thickness: 70 μ m).

9. Static characteristics

Table 42. Static characteristics

$T_{vj} = -40\text{ }^{\circ}\text{C}$ to $+150\text{ }^{\circ}\text{C}$; $V_{BAT} = 3\text{ V}$ to 28 V ; $R_L = R_{(CANH-CANL)} = 60\ \Omega$; all voltages are defined with respect to ground; positive currents flow into the IC; typical values are given at $V_{BAT} = 13\text{ V}$; unless otherwise specified. [1]

Symbol	Parameter	Conditions	Min	Typ	Max	Unit
Supply; pin BAT						
$V_{th(det)pon}$	power-on detection threshold voltage	V_{BAT} rising	4.2	-	4.55	V
$V_{th(det)poff}$	power-off detection threshold voltage	V_{BAT} falling	2.8	-	3	V
$V_{uvr(CAN)}$	CAN undervoltage recovery voltage	V_{BAT} rising	4.5	-	5	V
$V_{uvd(CAN)}$	CAN undervoltage detection voltage	V_{BAT} falling	4.2	-	4.55	V
I_{BAT}	battery supply current	Normal mode; MC = 111; CAN Active mode				
		CAN recessive; $V_{TXD} = V_{V1}$	-	4	7.5	mA
		CAN dominant; $V_{TXD} = 0\text{ V}$	-	46	67	mA
		Standby mode; MC = 100; CWE = 1; CAN Offline mode; $I_{V1} = 0\ \mu\text{A}$; $V_{BAT} = 7\text{ V}$ to 18 V ; $-40\text{ }^{\circ}\text{C} < T_{vj} < 85\text{ }^{\circ}\text{C}$	-	[2]	91	μA
	additional current in CAN Offline Bias mode; $-40\text{ }^{\circ}\text{C} < T_{vj} < 85\text{ }^{\circ}\text{C}$	-	38	55	μA	
Voltage source: pin V1						
V_O	output voltage	$V_{BAT} = 5.5\text{ V}$ to 28 V ; $I_{V1} = -120\text{ mA}$ to 0 mA ; $V_{TXD} = V_{V1}$	4.9	5	5.1	V
		$V_{BAT} = 5.65\text{ V}$ to 28 V ; $V_{TXD} = V_{V1}$; $I_{V1} = -150\text{ mA}$ to 0 mA ;	4.9	5	5.1	V
		$V_{BAT} = 5.65\text{ V}$ to 28 V ; $I_{V1} = -100\text{ mA}$ to 0 mA ; $V_{TXD} = 0\text{ V}$; $V_{CANH} = 0\text{ V}$	4.9	5	5.1	V
$\Delta V_{ret(RAM)}$	RAM retention voltage difference	$V_{BAT} = 2\text{ V}$ to 3 V ; $I_{V1} = -2\text{ mA}$	-	-	100	mV
		$V_{BAT} = 2\text{ V}$ to 3 V ; $I_{V1} = -200\ \mu\text{A}$			10	mV

Table 42. Static characteristics ...continued

$T_{vj} = -40\text{ °C to }+150\text{ °C}$; $V_{BAT} = 3\text{ V to }28\text{ V}$; $R_L = R_{(CANH-CANL)} = 60\ \Omega$; all voltages are defined with respect to ground; positive currents flow into the IC; typical values are given at $V_{BAT} = 13\text{ V}$; unless otherwise specified. [1]

Symbol	Parameter	Conditions	Min	Typ	Max	Unit
$R_{(BAT-V1)}$	resistance between pin BAT and pin V1	$V_{BAT} = 4\text{ V to }6\text{ V}$; $I_{V1} = -120\text{ mA}$; $T_{vj} < 150\text{ °C}$	-	-	5	Ω
		$V_{BAT} = 3\text{ V to }4\text{ V}$; $I_{V1} = -40\text{ mA}$	-	2.625	-	Ω
V_{uvd}	undervoltage detection voltage	$V_{uvd(nom)} = 90\%$	4.5	-	4.75	V
		$V_{uvd(nom)} = 80\%$	4	-	4.25	V
		$V_{uvd(nom)} = 70\%$	3.5	-	3.75	V
		$V_{uvd(nom)} = 60\%$	3	-	3.25	V
V_{uvr}	undervoltage recovery voltage		4.5	-	4.75	V
$I_{O(sc)}$	short-circuit output current		-300	-	-150	mA
$I_{CAN(int)V1}$	internal CAN supply current from V1	Normal mode; MC = 111; CAN Active mode; CAN dominant; $V_{TXD} = 0\text{ V}$; short-circuit on bus lines; $-3\text{ V} < (V_{CANH} = V_{CANL}) < +18\text{ V}$	-	-	59	mA
Serial peripheral interface inputs; pins SDI, SCK and SCSN						
$V_{th(sw)}$	switching threshold voltage		$0.25V_{V1}$	-	$0.75V_{V1}$	V
$V_{th(sw)hys}$	switching threshold voltage hysteresis		$0.05V_{V1}$	-	-	V
$R_{pd(SCK)}$	pull-down resistance on pin SCK		40	60	80	k Ω
$R_{pu(SCSN)}$	pull-up resistance on pin SCSN		40	60	80	k Ω
$R_{pd(SDI)}$	pull-down resistance on pin SDI	$V_{SDI} < V_{th(sw)}$	40	60	80	k Ω
$R_{pu(SDI)}$	pull-up resistance on pin SDI	$V_{SDI} > V_{th(sw)}$	40	60	80	k Ω
Serial peripheral interface data output; pin SDO						
V_{OH}	HIGH-level output voltage	$I_{OH} = -4\text{ mA}$	$V_{V1} - 0.4$	-	-	V
V_{OL}	LOW-level output voltage	$I_{OL} = 4\text{ mA}$	-	-	0.4	V
$I_{LO(off)}$	off-state output leakage current	$V_{SCSN} = V_{V1}$; $V_O = 0\text{ V to }V_{V1}$	-5	-	+5	μA
CAN transmit data input; pin TXD						
$V_{th(sw)}$	switching threshold voltage		$0.25V_{V1}$	-	$0.75V_{V1}$	V
$V_{th(sw)hys}$	switching threshold voltage hysteresis		$0.05V_{V1}$	-	-	V
R_{pu}	pull-up resistance		40	60	80	k Ω
CAN receive data output; pin RXD						
V_{OH}	HIGH-level output voltage	$I_{OH} = -4\text{ mA}$	$V_{V1} - 0.4$	-	-	V
V_{OL}	LOW-level output voltage	$I_{OL} = 4\text{ mA}$	-	-	0.4	V
R_{pu}	pull-up resistance	CAN Offline mode	40	60	80	k Ω
High-speed CAN bus lines; pins CANH and CANL						
$V_{O(dom)}$	dominant output voltage	CAN Active mode; $V_{TXD} = 0\text{ V}$; $t < t_{to(dom)TXD}$				
		pin CANH; $R_L = 50\ \Omega\text{ to }65\ \Omega$	2.75	3.5	4.5	V
		pin CANL; $R_L = 50\ \Omega\text{ to }65\ \Omega$	0.5	1.5	2.25	V

Table 42. Static characteristics ...continued

$T_{vj} = -40\text{ }^{\circ}\text{C}$ to $+150\text{ }^{\circ}\text{C}$; $V_{BAT} = 3\text{ V}$ to 28 V ; $R_L = R_{(CANH-CANL)} = 60\ \Omega$; all voltages are defined with respect to ground; positive currents flow into the IC; typical values are given at $V_{BAT} = 13\text{ V}$; unless otherwise specified. [1]

Symbol	Parameter	Conditions	Min	Typ	Max	Unit	
$V_{\text{dom(TX)sym}}$	transmitter dominant voltage symmetry	$V_{\text{dom(TX)sym}} = V_{V1} - V_{\text{CANH}} - V_{\text{CANL}}$; $V_{V1} = 5\text{ V}$	-400	-	+400	mV	
V_{TXsym}	transmitter voltage symmetry	$V_{\text{TXsym}} = V_{\text{CANH}} + V_{\text{CANL}}$; $f_{\text{TXD}} = 250\text{ kHz}$, 1 MHz or 2.5 MHz ; $C_{\text{SPLIT}} = 4.7\text{ nF}$	0.9 V_{V1} [3]	-	1.1 V_{V1} [4]	V	
$V_{\text{O(dif)}}$	differential output voltage	CAN Active mode (dominant); $V_{\text{TXD}} = 0\text{ V}$; $V_{V1} = 4.75\text{ V}$ to 5.5 V ; $t < t_{\text{to(dom)TXD}}$					
		$R_L = 50\ \Omega$ to $65\ \Omega$	1.5	-	3	V	
		$R_L = 45\ \Omega$ to $70\ \Omega$	1.4	-	3.3	V	
		$R_L = 2240\ \Omega$	1.5	-	5	V	
		recessive; $R_L = \text{no load}$					
		CAN Active/Listen-only/Offline Bias mode; $V_{\text{TXD}} = V_{V1}$	-50	-	+50	mV	
$V_{\text{O(rec)}}$	recessive output voltage	CAN Active mode; $V_{\text{TXD}} = V_{V1}$ $R_L = \text{no load}$	2	0.5 V_{V1}	3	V	
		CAN Offline mode; $R_L = \text{no load}$	-0.1	-	+0.1	V	
		CAN Offline Bias/Listen-only modes; $R_L = \text{no load}$	2	2.5	3	V	
$I_{\text{O(sc)dom}}$	dominant short-circuit output current	CAN Active mode; $V_{\text{TXD}} = 0\text{ V}$; $V_{V1} = 5\text{ V}$					
		pin CANH; $V_{\text{CANH}} = -3\text{ V}$ to $+27\text{ V}$	-55	-	-	mA	
		pin CANL; $V_{\text{CANL}} = -15\text{ V}$ to $+18\text{ V}$	-	-	+55	mA	
$I_{\text{O(sc)rec}}$	recessive short-circuit output current	$V_{\text{CANL}} = V_{\text{CANH}} = -27\text{ V}$ to $+32\text{ V}$; $V_{\text{TXD}} = V_{V1}$	-3	-	+3	mA	
$V_{\text{th(RX)dif}}$	differential receiver threshold voltage	$-12\text{ V} \leq V_{\text{CANL}} \leq +12\text{ V}$; $-12\text{ V} \leq V_{\text{CANH}} \leq +12\text{ V}$					
		CAN Active/Listen-only modes	0.5	0.7	0.9	V	
		CAN Offline mode	0.4	0.7	1.15	V	
$V_{\text{rec(RX)}}$	receiver recessive voltage	$-12\text{ V} \leq V_{\text{CANL}} \leq +12\text{ V}$; $-12\text{ V} \leq V_{\text{CANH}} \leq +12\text{ V}$					
		CAN Active/Listen-only modes	-4 [3]	-	+0.5	V	
		CAN Offline/Offline Bias modes	-4 [3]	-	+0.4	V	
$V_{\text{dom(RX)}}$	receiver dominant voltage	$-12\text{ V} \leq V_{\text{CANL}} \leq +12\text{ V}$; $-12\text{ V} \leq V_{\text{CANH}} \leq +12\text{ V}$					
		CAN Active/Listen-only modes	0.9	-	9.0 [3]	V	
		CAN Offline/Offline Bias modes	1.15	-	9.0 [3]	V	
$V_{\text{hys(RX)dif}}$	differential receiver hysteresis voltage	CAN Active/Listen-only modes; $-12\text{ V} \leq V_{\text{CANL}} \leq +12\text{ V}$; $-12\text{ V} \leq V_{\text{CANH}} \leq +12\text{ V}$	1	30	60	mV	

Table 42. Static characteristics ...continued

$T_{vj} = -40\text{ °C to }+150\text{ °C}$; $V_{BAT} = 3\text{ V to }28\text{ V}$; $R_L = R_{(CANH-CANL)} = 60\ \Omega$; all voltages are defined with respect to ground; positive currents flow into the IC; typical values are given at $V_{BAT} = 13\text{ V}$; unless otherwise specified. [1]

Symbol	Parameter	Conditions	Min	Typ	Max	Unit
R_i	input resistance	$-2\text{ V} \leq V_{CANL} \leq +7\text{ V}$; $-2\text{ V} \leq V_{CANH} \leq +7\text{ V}$	9	15	28	k Ω
ΔR_i	input resistance deviation	$0\text{ V} \leq V_{CANL} \leq +5\text{ V}$; $0\text{ V} \leq V_{CANH} \leq +5\text{ V}$	-1	-	+1	%
$R_{i(dif)}$	differential input resistance	$-2\text{ V} \leq V_{CANL} \leq +7\text{ V}$; $-2\text{ V} \leq V_{CANH} \leq +7\text{ V}$	19	30	52	k Ω
$C_{i(cm)}$	common-mode input capacitance	[3]	-	-	20	pF
$C_{i(dif)}$	differential input capacitance	[3]	-	-	10	pF
I_L	leakage current	$V_{BAT} = V_{V1} = 0\text{ V}$ or $V_{BAT} = V_{V1} =$ shorted to ground via 47 k Ω ; $V_{CANH} = V_{CANL} = 5\text{ V}$	-5	-	+5	μA
Temperature protection						
$T_{th(act)otp}$	overtemperature protection activation threshold temperature		167	177	187	$^{\circ}\text{C}$
$T_{th(rel)otp}$	overtemperature protection release threshold temperature		127	137	147	$^{\circ}\text{C}$
$T_{th(warn)otp}$	overtemperature protection warning threshold temperature		127	137	147	$^{\circ}\text{C}$
Reset output; pin RSTN						
V_{OL}	LOW-level output voltage	$V_{V1} = 1.0\text{ V to }5.5\text{ V}$; pull-up resistor to $V_{V1} \geq 900\ \Omega$	0	-	$0.2V_{V1}$	V
R_{pu}	pull-up resistance		40	60	80	k Ω
$V_{th(sw)}$	switching threshold voltage		$0.25V_{V1}$	-	$0.75V_{V1}$	V
$V_{th(sw)hys}$	switching threshold voltage hysteresis		$0.05V_{V1}$	-	-	V
MTP non-volatile memory						
$N_{cy(W)MTP}$	number of MTP write cycles	$V_{BAT} = 6\text{ V to }28\text{ V}$; $T_{vj} = 0\text{ °C to }+125\text{ °C}$	-	-	200	-

- [1] All parameters are guaranteed over the virtual junction temperature range by design. Factory testing uses correlated test conditions to cover the specified temperature and power supply voltage range.
- [2] See [Figure 10](#).
- [3] Not tested in production; guaranteed by design.
- [4] The test circuit used to measure the bus output voltage symmetry (which includes C_{SPLIT}) is shown in [Figure 16](#).

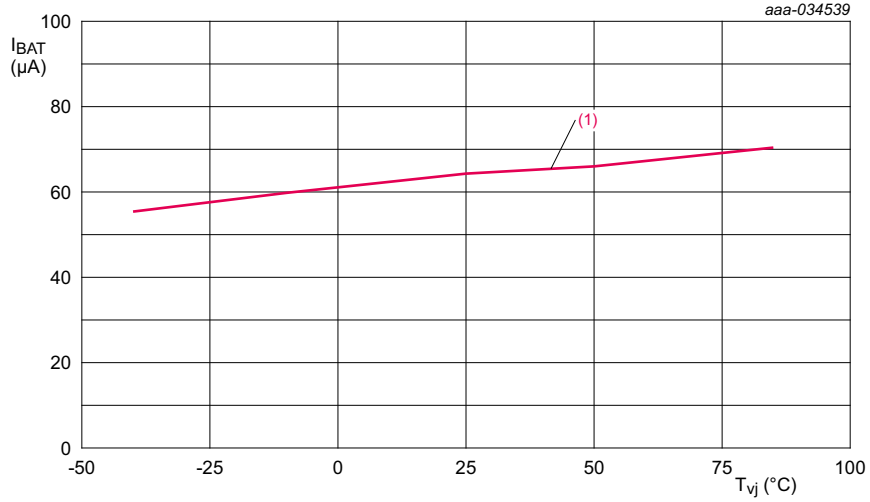

(1) Standby Mode: MC = 100, CWE = 1, CAN Offline mode, V_{BAT} = 12 V, I_{V1} = 0 μA.

Fig 10. UJA1164A typical Standby quiescent current (μA)

10. Dynamic characteristics

Table 43. Dynamic characteristics

$T_{Vj} = -40\text{ °C to }+150\text{ °C}$; $V_{BAT} = 3\text{ V to }28\text{ V}$; $R_L = R_{(CANH-CANL)} = 60\ \Omega$; all voltages are defined with respect to ground; positive currents flow into the IC; typical values are given at $V_{BAT} = 13\text{ V}$; unless otherwise specified.^[1]

Symbol	Parameter	Conditions	Min	Typ	Max	Unit	
Voltage source; pin V1							
t_{startup}	start-up time	from V_{BAT} exceeding the power-on detection threshold until V_{V1} exceeds the 90 % undervoltage threshold; $C_{V1} = 4.7\ \mu\text{F}$	-	2.8	4.7	ms	
$t_{\text{d(uvd)}}$	undervoltage detection delay time		6	-	54	μs	
$t_{\text{d(uvd-RSTNL)}}$	delay time from undervoltage detection to RSTN LOW	undervoltage on V1	-	-	63	μs	
$t_{\text{d(buswake-VOH)}}$	delay time from bus wake-up to HIGH-level output voltage	HIGH = $0.8V_{O(V1)}$; $I_{V1} \leq 100\text{ mA}$	-	-	5	ms	
Serial peripheral interface timing; pins SCSN, SCK, SDI and SDO; see Figure 13							
$t_{\text{cy(clk)}}$	clock cycle time		250	-	-	ns	
t_{SPILEAD}	SPI enable lead time		50	-	-	ns	
t_{SPILAG}	SPI enable lag time		50	-	-	ns	
$t_{\text{clk(H)}}$	clock HIGH time		100	-	-	ns	
$t_{\text{clk(L)}}$	clock LOW time		100	-	-	ns	
$t_{\text{su(D)}}$	data input set-up time		50	-	-	ns	
$t_{\text{h(D)}}$	data input hold time		50	-	-	ns	
$t_{\text{v(Q)}}$	data output valid time	pin SDO; $C_L = 20\text{ pF}$	-	-	50	ns	
$t_{\text{d(SDI-SDO)}}$	SDI to SDO delay time	SPI address bits and read-only bit; $C_L = 20\text{ pF}$	-	-	50	ns	
$t_{\text{WH(S)}}$	chip select pulse width HIGH	pin SCSN	250	-	-	ns	
$t_{\text{d(SCKL-SCSNL)}}$	delay time from SCK LOW to SCSN LOW		50	-	-	ns	
CAN transceiver timing; pins CANH, CANL, TXD and RXD							
$t_{\text{d(TXD-busdom)}}$	delay time from TXD to bus dominant		^[2]	-	80	-	ns
$t_{\text{d(TXD-busrec)}}$	delay time from TXD to bus recessive		^[2]	-	80	-	ns
$t_{\text{d(busdom-RXD)}}$	delay time from bus dominant to RXD		^[2]	-	105	-	ns
$t_{\text{d(busrec-RXD)}}$	delay time from bus recessive to RXD		^[2]	-	120	-	ns
$t_{\text{d(TXDL-RXD)}}$	delay time from TXD LOW to RXD LOW	$t_{\text{bit(TXD)}} = 200\text{ ns}$	^[3]	-	-	255	ns
$t_{\text{d(TXDH-RXD)}}$	delay time from TXD HIGH to RXD HIGH	$t_{\text{bit(TXD)}} = 200\text{ ns}$	^[3]	-	-	255	ns
$t_{\text{bit(bus)}}$	transmitted recessive bit width	$t_{\text{bit(TXD)}} = 500\text{ ns}$	^[3]	435	-	530	ns
		$t_{\text{bit(TXD)}} = 200\text{ ns}$	^[3]	155	-	210	ns

Table 43. Dynamic characteristics ...continued

$T_{vj} = -40\text{ }^{\circ}\text{C to } +150\text{ }^{\circ}\text{C}$; $V_{BAT} = 3\text{ V to } 28\text{ V}$; $R_L = R_{(CANH-CANL)} = 60\text{ }\Omega$; all voltages are defined with respect to ground; positive currents flow into the IC; typical values are given at $V_{BAT} = 13\text{ V}$; unless otherwise specified. [1]

Symbol	Parameter	Conditions	Min	Typ	Max	Unit
$t_{bit(RXD)}$	bit time on pin RXD	$t_{bit(TXD)} = 500\text{ ns}$ [3]	400	-	550	ns
		$t_{bit(TXD)} = 200\text{ ns}$ [3]	120	-	220	ns
Δt_{rec}	receiver timing symmetry	$t_{bit(TXD)} = 500\text{ ns}$	-65	-	+40	ns
		$t_{bit(TXD)} = 200\text{ ns}$	-45	-	+15	ns
$t_{wake(busdom)}$	bus dominant wake-up time	first pulse (after first recessive) for wake-up on pins CANH and CANL; CAN Offline mode	0.5	-	1.8	μs
		second pulse for wake-up on pins CANH and CANL	0.5	-	1.8	μs
$t_{wake(busrec)}$	bus recessive wake-up time	first pulse for wake-up on pins CANH and CANL; CAN Offline mode	0.5	-	1.8	μs
		second pulse (after first dominant) for wake-up on pins CANH and CANL	0.5	-	1.8	μs
$t_{to(wake)bus}$	bus wake-up time-out time	between first and second dominant pulses; CAN Offline mode	0.8	-	10	ms
$t_{to(dom)TXD}$	TXD dominant time-out time	CAN Active mode; $V_{TXD} = 0\text{ V}$	2.7	-	3.3	ms
$t_{to(silence)}$	bus silence time-out time	recessive time measurement started in all CAN modes	0.95	-	1.17	s
$t_d(busact-bias)$	delay time from bus active to bias		-	-	200	μs
$t_{startup(CAN)}$	CAN start-up time	when switching to Active mode (CTS = 1)	-	-	220	μs
Pin RXD: event capture timing (valid in CAN Offline mode only)						
$t_d(event)$	event capture delay time	CAN Offline mode	0.9	-	1.1	ms
t_{blank}	blanking time	when switching from Offline to Active/Listen-only mode	-	-	25	μs
Watchdog						
$t_{trig(wd)1}$	watchdog trigger time 1	Normal mode; watchdog Window mode only [4]	$0.45 \times$ NWP [5]	-	$0.55 \times$ NWP [5]	ms
$t_{trig(wd)2}$	watchdog trigger time 2	Normal/Standby mode [6]	$0.9 \times$ NWP [5]	-	$1.11 \times$ NWP [5]	ms
$t_d(SCSNH-RSTNL)$	delay time from SCSN HIGH to RSTN LOW	rising edge to falling edge; watchdog in window mode, triggered in the first half of the watchdog period (before $t_{trig(wd)1}$) [7]	-	-	0.2	ms
Pin RSTN: reset pulse width						
$t_w(rst)$	reset pulse width	output pulse width				
		RLC = 00	20	-	25	ms
		RLC = 01	10	-	12.5	ms
		RLC = 10	3.6	-	5	ms
		RLC = 11	1	-	1.5	ms
		input pulse width	18	-	-	μs
MTP non-volatile memory						

Table 43. Dynamic characteristics ...continued

$T_{vj} = -40\text{ °C to }+150\text{ °C}$; $V_{BAT} = 3\text{ V to }28\text{ V}$; $R_L = R_{(CANH-CANL)} = 60\ \Omega$; all voltages are defined with respect to ground; positive currents flow into the IC; typical values are given at $V_{BAT} = 13\text{ V}$; unless otherwise specified. [1]

Symbol	Parameter	Conditions	Min	Typ	Max	Unit
$t_{ret(data)}$	data retention time	$T_{vj} = 90\text{ °C}$	20	-	-	year
$t_{d(MTPNV)}$	MTPNV delay time	before factory presets are restored; $V_{BAT} = 6\text{ V to }28\text{ V}$	0.9	-	1.1	s
$t_{prog(MTPNV)}$	MTPNV programming time	correct CRC code received at address 0x75; $V_{BAT} = 6\text{ V to }28\text{ V}$	10	12	14	ms
Mode transition						
$t_{d(act)norm}$	normal mode activation delay time	MC = 111; delay before CAN transceiver gets activated after the SBC switches to Normal mode	-	-	320	μs

- [1] All parameters are guaranteed over the virtual junction temperature range by design. Factory testing uses correlated test conditions to cover the specified temperature and power supply voltage range.
- [2] See [Figure 11](#) and [Figure 15](#).
- [3] See [Figure 12](#) and [Figure 15](#).
- [4] A system reset will be performed if the watchdog is in Window mode and is triggered less than $t_{trig(wd)1}$ after the start of the watchdog period (or in the first half of the watchdog period).
- [5] The nominal watchdog period is programmed via the NWP control bits.
- [6] The watchdog will be reset if it is in window mode and is triggered at least $t_{trig(wd)1}$, but not more than $t_{trig(wd)2}$, after the start of the watchdog period (or in the second half of the watchdog period). A system reset will be performed if the watchdog is triggered more than $t_{trig(wd)2}$ after the start of the watchdog period (watchdog overflows).
- [7] Not tested in production; guaranteed by design.

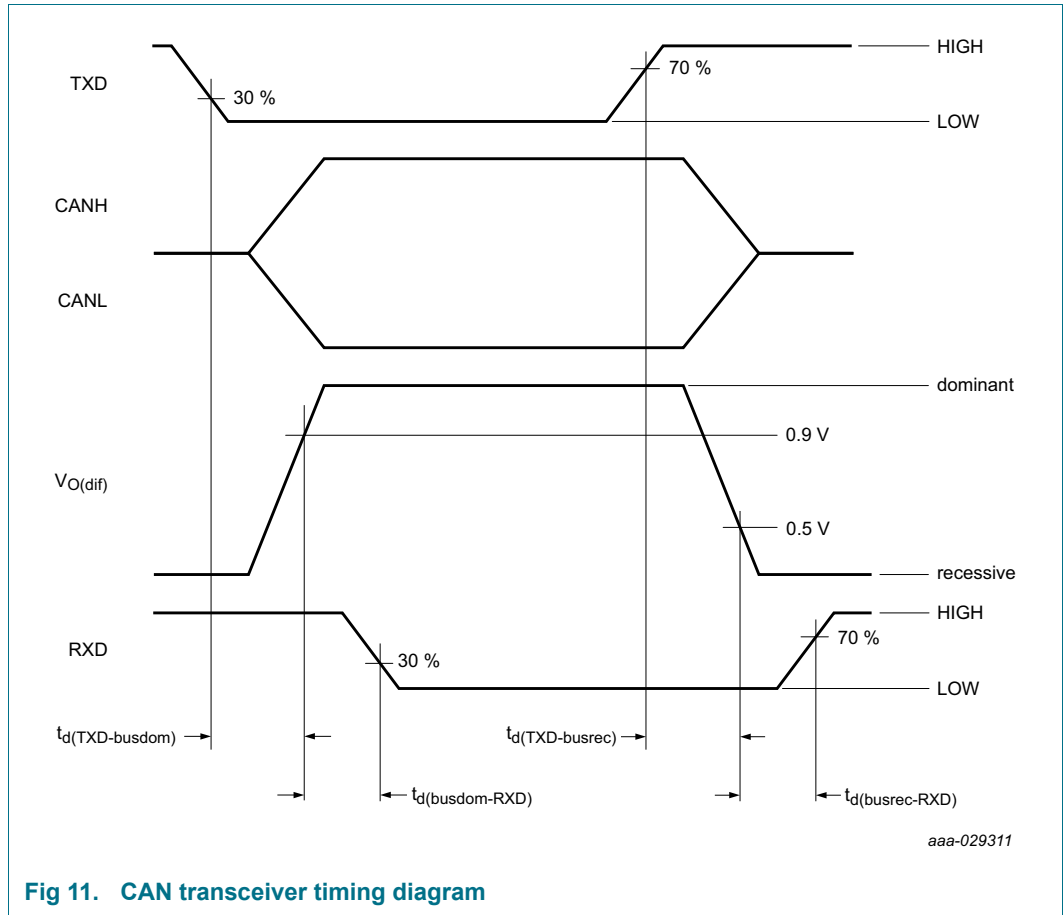

Fig 11. CAN transceiver timing diagram

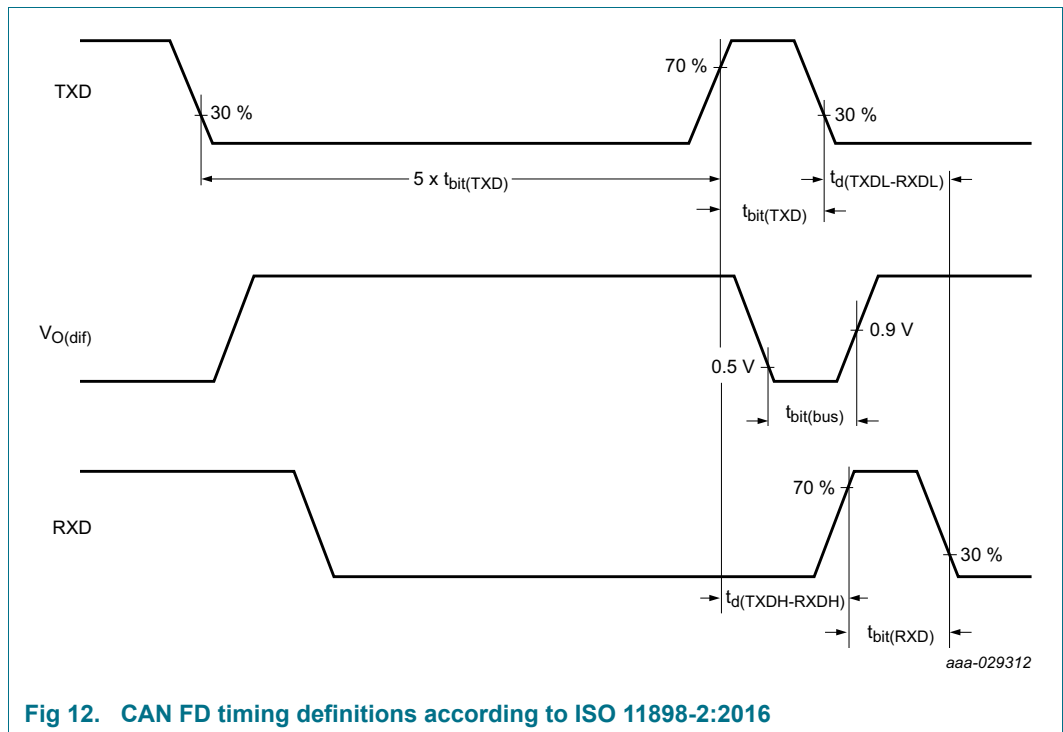
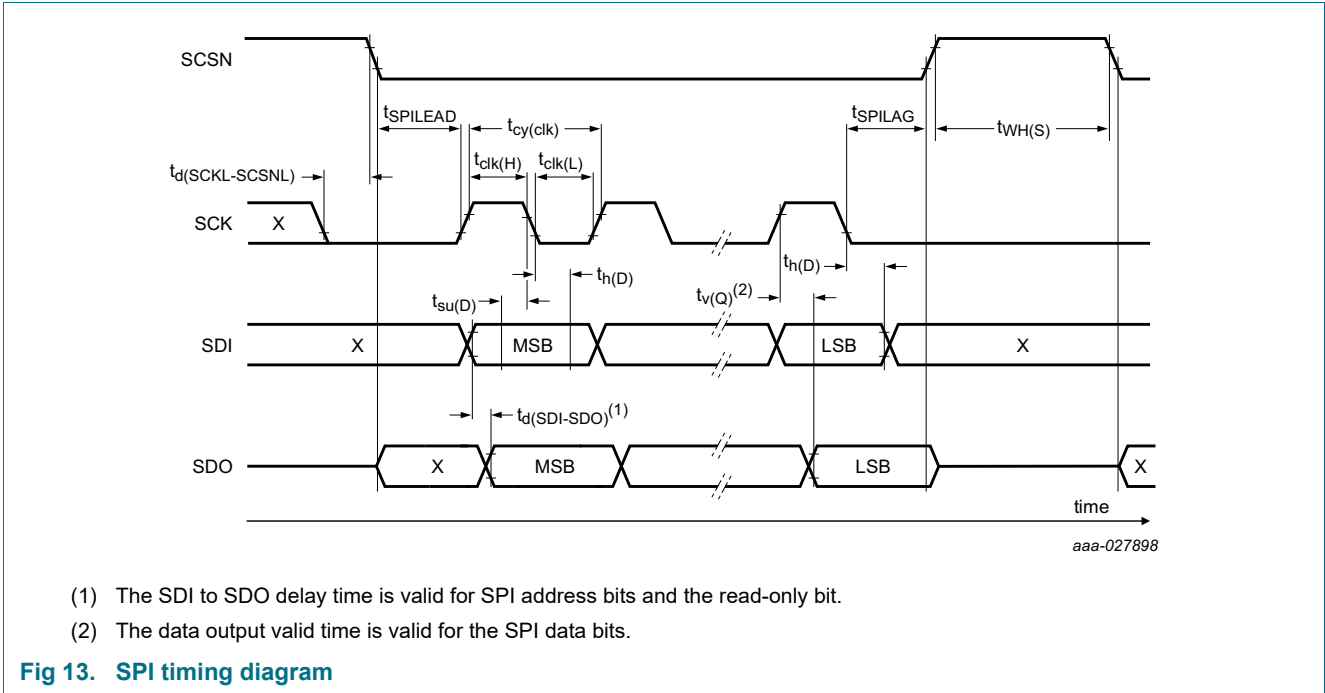

Fig 12. CAN FD timing definitions according to ISO 11898-2:2016



- (1) The SDI to SDO delay time is valid for SPI address bits and the read-only bit.
- (2) The data output valid time is valid for the SPI data bits.

Fig 13. SPI timing diagram

11. Application information

11.1 Application diagram

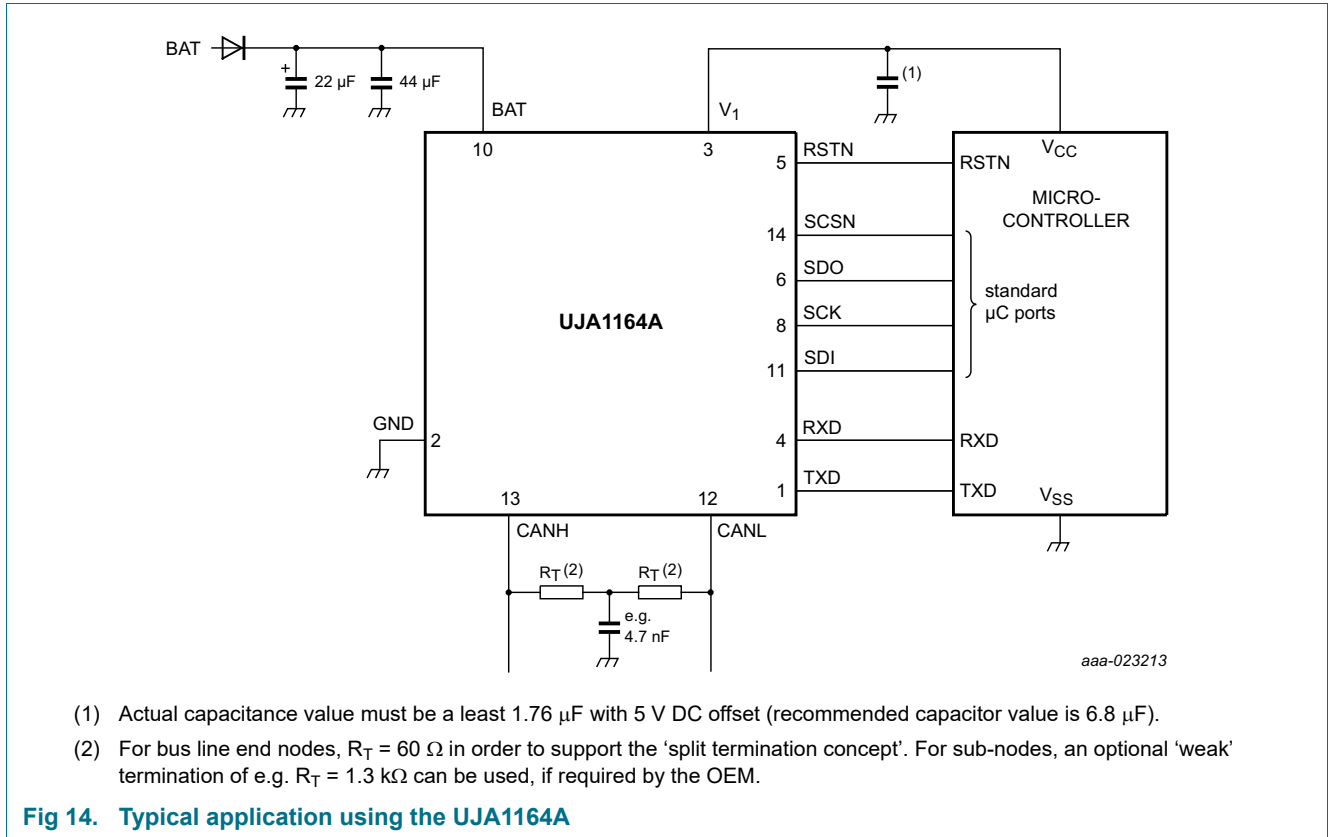

11.2 Application hints

Further information on the application of the UJA1164A can be found in the NXP application hints document *AH1902 Application Hints - Mini high speed CAN system basis chips UJA116xA*.

12. Test information

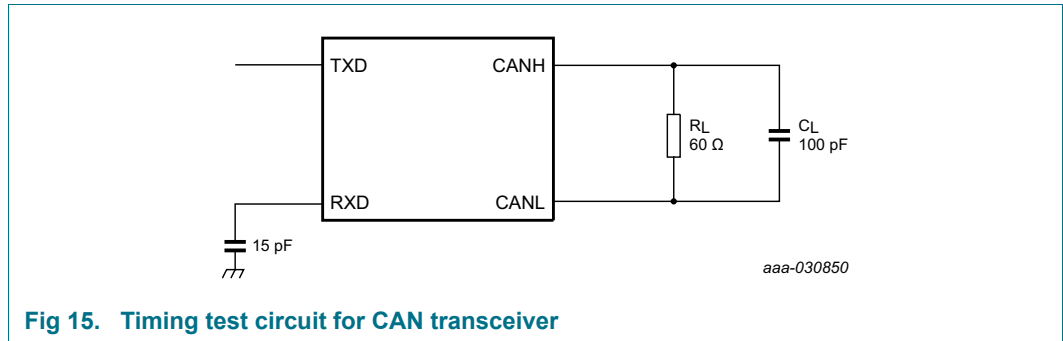

Fig 15. Timing test circuit for CAN transceiver

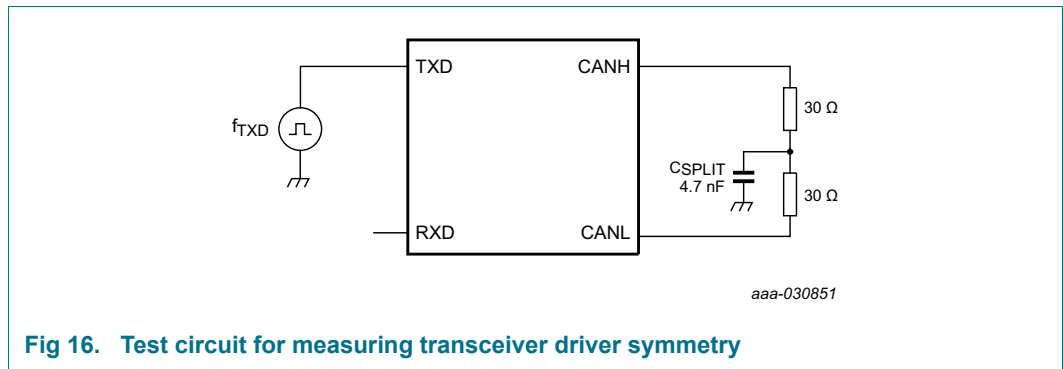

Fig 16. Test circuit for measuring transceiver driver symmetry

12.1 Quality information

This product has been qualified in accordance with the Automotive Electronics Council (AEC) standard Q100 Rev-G - *Failure mechanism based stress test qualification for integrated circuits*, and is suitable for use in automotive applications.

13. Package outline

HVSON14: plastic, thermal enhanced very thin small outline package; no leads; 14 terminals; body 3 x 4.5 x 0.85 mm

SOT1086-2

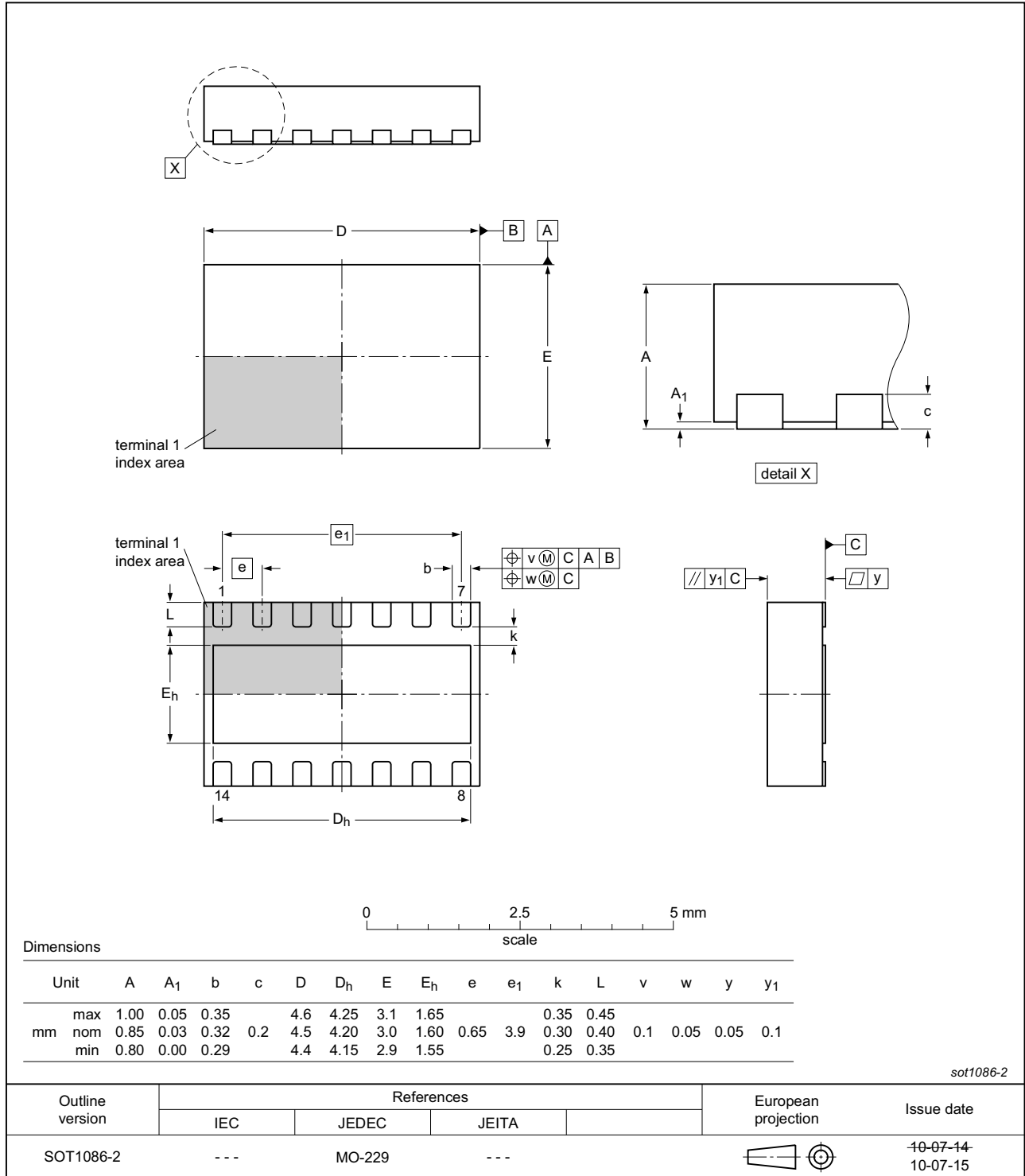

Fig 17. Package outline SOT1086-2 (HVSON14)

14. Handling information

All input and output pins are protected against ElectroStatic Discharge (ESD) under normal handling. When handling ensure that the appropriate precautions are taken as described in *JESD625-A* or equivalent standards.

15. Soldering of SMD packages

This text provides a very brief insight into a complex technology. A more in-depth account of soldering ICs can be found in Application Note *AN10365 "Surface mount reflow soldering description"*.

15.1 Introduction to soldering

Soldering is one of the most common methods through which packages are attached to Printed Circuit Boards (PCBs), to form electrical circuits. The soldered joint provides both the mechanical and the electrical connection. There is no single soldering method that is ideal for all IC packages. Wave soldering is often preferred when through-hole and Surface Mount Devices (SMDs) are mixed on one printed wiring board; however, it is not suitable for fine pitch SMDs. Reflow soldering is ideal for the small pitches and high densities that come with increased miniaturization.

15.2 Wave and reflow soldering

Wave soldering is a joining technology in which the joints are made by solder coming from a standing wave of liquid solder. The wave soldering process is suitable for the following:

- Through-hole components
- Leaded or leadless SMDs, which are glued to the surface of the printed circuit board

Not all SMDs can be wave soldered. Packages with solder balls, and some leadless packages which have solder lands underneath the body, cannot be wave soldered. Also, leaded SMDs with leads having a pitch smaller than ~0.6 mm cannot be wave soldered, due to an increased probability of bridging.

The reflow soldering process involves applying solder paste to a board, followed by component placement and exposure to a temperature profile. Leaded packages, packages with solder balls, and leadless packages are all reflow solderable.

Key characteristics in both wave and reflow soldering are:

- Board specifications, including the board finish, solder masks and vias
- Package footprints, including solder thieves and orientation
- The moisture sensitivity level of the packages
- Package placement
- Inspection and repair
- Lead-free soldering versus SnPb soldering

15.3 Wave soldering

Key characteristics in wave soldering are:

- Process issues, such as application of adhesive and flux, clinching of leads, board transport, the solder wave parameters, and the time during which components are exposed to the wave
- Solder bath specifications, including temperature and impurities

15.4 Reflow soldering

Key characteristics in reflow soldering are:

- Lead-free versus SnPb soldering; note that a lead-free reflow process usually leads to higher minimum peak temperatures (see [Figure 18](#)) than a SnPb process, thus reducing the process window
- Solder paste printing issues including smearing, release, and adjusting the process window for a mix of large and small components on one board
- Reflow temperature profile; this profile includes preheat, reflow (in which the board is heated to the peak temperature) and cooling down. It is imperative that the peak temperature is high enough for the solder to make reliable solder joints (a solder paste characteristic). In addition, the peak temperature must be low enough that the packages and/or boards are not damaged. The peak temperature of the package depends on package thickness and volume and is classified in accordance with [Table 44](#) and [45](#)

Table 44. SnPb eutectic process (from J-STD-020D)

Package thickness (mm)	Package reflow temperature (°C)	
	Volume (mm ³)	
	< 350	≥ 350
< 2.5	235	220
≥ 2.5	220	220

Table 45. Lead-free process (from J-STD-020D)

Package thickness (mm)	Package reflow temperature (°C)		
	Volume (mm ³)		
	< 350	350 to 2000	> 2000
< 1.6	260	260	260
1.6 to 2.5	260	250	245
> 2.5	250	245	245

Moisture sensitivity precautions, as indicated on the packing, must be respected at all times.

Studies have shown that small packages reach higher temperatures during reflow soldering, see [Figure 18](#).

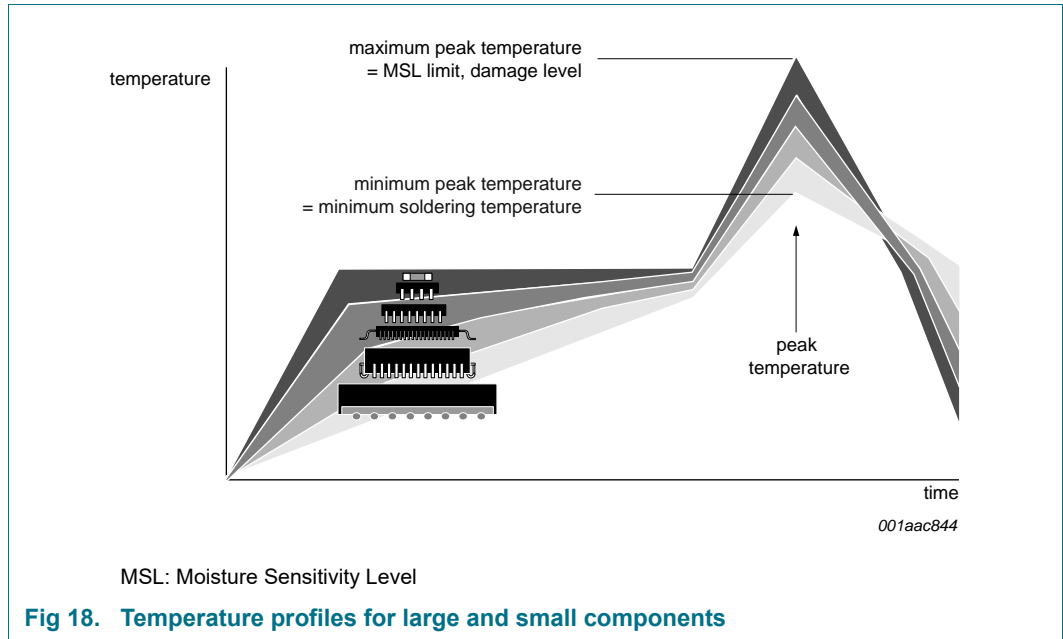

For further information on temperature profiles, refer to Application Note *AN10365* “*Surface mount reflow soldering description*”.

16. Soldering of HVSON packages

[Section 15](#) contains a brief introduction to the techniques most commonly used to solder Surface Mounted Devices (SMD). A more detailed discussion on soldering HVSON leadless package ICs can found in the following application notes:

- *AN10365* “*Surface mount reflow soldering description*”
- *AN10366* “*HVQFN application information*”

17. Appendix: ISO 11898-2:201x parameter cross-reference list

Table 46. ISO 11898-2:201x to NXP data sheet parameter conversion

ISO 11898-2:201x		NXP data sheet	
Parameter	Notation	Symbol	Parameter
HS-PMA dominant output characteristics			
Single ended voltage on CAN_H	V_{CAN_H}	$V_{O(dom)}$	dominant output voltage
Single ended voltage on CAN_L	V_{CAN_L}		
Differential voltage on normal bus load	V_{Diff}	$V_{O(dif)}$	differential output voltage
Differential voltage on effective resistance during arbitration			
Optional: Differential voltage on extended bus load range			
HS-PMA driver symmetry			
Driver symmetry	V_{SYM}	V_{TXsym}	transmitter voltage symmetry
Maximum HS-PMA driver output current			
Absolute current on CAN_H	I_{CAN_H}	$I_{O(sc)dom}$	dominant short-circuit output current
Absolute current on CAN_L	I_{CAN_L}		
HS-PMA recessive output characteristics, bus biasing active/inactive			
Single ended output voltage on CAN_H	V_{CAN_H}	$V_{O(rec)}$	recessive output voltage
Single ended output voltage on CAN_L	V_{CAN_L}		
Differential output voltage	V_{Diff}	$V_{O(dif)}$	differential output voltage
Optional HS-PMA transmit dominant timeout			
Transmit dominant timeout, long	t_{dom}	$t_{to(dom)TXD}$	TXD dominant time-out time
Transmit dominant timeout, short			
HS-PMA static receiver input characteristics, bus biasing active/inactive			
Recessive state differential input voltage range	V_{Diff}	$V_{th(RX)dif}$	differential receiver threshold voltage
Dominant state differential input voltage range		$V_{rec(RX)}$	receiver recessive voltage
		$V_{dom(RX)}$	receiver dominant voltage
HS-PMA receiver input resistance (matching)			
Differential internal resistance	R_{Diff}	$R_{i(dif)}$	differential input resistance
Single ended internal resistance	R_{CAN_H} R_{CAN_L}	R_i	input resistance
Matching of internal resistance	MR	ΔR_i	input resistance deviation
HS-PMA implementation loop delay requirement			
Loop delay	t_{Loop}	$t_{d(TXDH-RXDH)}$	delay time from TXD HIGH to RXD HIGH
		$t_{d(TXDL-RXDL)}$	delay time from TXD LOW to RXD LOW
Optional HS-PMA implementation data signal timing requirements for use with bit rates above 1 Mbit/s up to 2 Mbit/s and above 2 Mbit/s up to 5 Mbit/s			
Transmitted recessive bit width @ 2 Mbit/s / @ 5 Mbit/s, intended	$t_{Bit(Bus)}$	$t_{bit(bus)}$	transmitted recessive bit width
Received recessive bit width @ 2 Mbit/s / @ 5 Mbit/s	$t_{Bit(RXD)}$	$t_{bit(RXD)}$	bit time on pin RXD
Receiver timing symmetry @ 2 Mbit/s / @ 5 Mbit/s	Δt_{Rec}	Δt_{rec}	receiver timing symmetry

Table 46. ISO 11898-2:201x to NXP data sheet parameter conversion

ISO 11898-2:201x		NXP data sheet	
Parameter	Notation	Symbol	Parameter
HS-PMA maximum ratings of V_{CAN_H}, V_{CAN_L} and V_{Diff}			
Maximum rating V _{Diff}	V _{Diff}	V _(CANH-CANL)	voltage between pin CANH and pin CANL
General maximum rating V _{CAN_H} and V _{CAN_L}	V _{CAN_H}	V _x	voltage on pin x
Optional: Extended maximum rating V _{CAN_H} and V _{CAN_L}	V _{CAN_L}		
HS-PMA maximum leakage currents on CAN_H and CAN_L, unpowered			
Leakage current on CAN_H, CAN_L	I _{CAN_H} I _{CAN_L}	I _L	leakage current
HS-PMA bus biasing control timings			
CAN activity filter time, long	t _{Filter}	t _{wake(busdom)} ^[1]	bus dominant wake-up time
CAN activity filter time, short		t _{wake(busrec)} ^[1]	bus recessive wake-up time
Wake-up timeout, short	t _{Wake}	t _{to(wake)bus}	bus wake-up time-out time
Wake-up timeout, long			
Timeout for bus inactivity	t _{Silence}	t _{to(silence)}	bus silence time-out time
Bus Bias reaction time	t _{Bias}	t _{d(busact-bias)}	delay time from bus active to bias

[1] t_{fltr(wake)bus} - bus wake-up filter time, in devices with basic wake-up functionality

18. Revision history

Table 47. Revision history

Document ID	Release date	Data sheet status	Change notice	Supersedes
UJA1164A v.1	20190823	Product data sheet	-	-

19. Legal information

19.1 Data sheet status

Document status ^{[1][2]}	Product status ^[3]	Definition
Objective [short] data sheet	Development	This document contains data from the objective specification for product development.
Preliminary [short] data sheet	Qualification	This document contains data from the preliminary specification.
Product [short] data sheet	Production	This document contains the product specification.

[1] Please consult the most recently issued document before initiating or completing a design.

[2] The term 'short data sheet' is explained in section "Definitions".

[3] The product status of device(s) described in this document may have changed since this document was published and may differ in case of multiple devices. The latest product status information is available on the Internet at URL <http://www.nxp.com>.

19.2 Definitions

Draft — The document is a draft version only. The content is still under internal review and subject to formal approval, which may result in modifications or additions. NXP Semiconductors does not give any representations or warranties as to the accuracy or completeness of information included herein and shall have no liability for the consequences of use of such information.

Short data sheet — A short data sheet is an extract from a full data sheet with the same product type number(s) and title. A short data sheet is intended for quick reference only and should not be relied upon to contain detailed and full information. For detailed and full information see the relevant full data sheet, which is available on request via the local NXP Semiconductors sales office. In case of any inconsistency or conflict with the short data sheet, the full data sheet shall prevail.

Product specification — The information and data provided in a Product data sheet shall define the specification of the product as agreed between NXP Semiconductors and its customer, unless NXP Semiconductors and customer have explicitly agreed otherwise in writing. In no event however, shall an agreement be valid in which the NXP Semiconductors product is deemed to offer functions and qualities beyond those described in the Product data sheet.

19.3 Disclaimers

Limited warranty and liability — Information in this document is believed to be accurate and reliable. However, NXP Semiconductors does not give any representations or warranties, expressed or implied, as to the accuracy or completeness of such information and shall have no liability for the consequences of use of such information. NXP Semiconductors takes no responsibility for the content in this document if provided by an information source outside of NXP Semiconductors.

In no event shall NXP Semiconductors be liable for any indirect, incidental, punitive, special or consequential damages (including - without limitation - lost profits, lost savings, business interruption, costs related to the removal or replacement of any products or rework charges) whether or not such damages are based on tort (including negligence), warranty, breach of contract or any other legal theory.

Notwithstanding any damages that customer might incur for any reason whatsoever, NXP Semiconductors' aggregate and cumulative liability towards customer for the products described herein shall be limited in accordance with the *Terms and conditions of commercial sale* of NXP Semiconductors.

Right to make changes — NXP Semiconductors reserves the right to make changes to information published in this document, including without limitation specifications and product descriptions, at any time and without notice. This document supersedes and replaces all information supplied prior to the publication hereof.

Suitability for use in automotive applications — This NXP Semiconductors product has been qualified for use in automotive applications. Unless otherwise agreed in writing, the product is not designed, authorized or warranted to be suitable for use in life support, life-critical or safety-critical systems or equipment, nor in applications where failure or malfunction of an NXP Semiconductors product can reasonably be expected to result in personal injury, death or severe property or environmental damage. NXP Semiconductors and its suppliers accept no liability for inclusion and/or use of NXP Semiconductors products in such equipment or applications and therefore such inclusion and/or use is at the customer's own risk.

Applications — Applications that are described herein for any of these products are for illustrative purposes only. NXP Semiconductors makes no representation or warranty that such applications will be suitable for the specified use without further testing or modification.

Customers are responsible for the design and operation of their applications and products using NXP Semiconductors products, and NXP Semiconductors accepts no liability for any assistance with applications or customer product design. It is customer's sole responsibility to determine whether the NXP Semiconductors product is suitable and fit for the customer's applications and products planned, as well as for the planned application and use of customer's third party customer(s). Customers should provide appropriate design and operating safeguards to minimize the risks associated with their applications and products.

NXP Semiconductors does not accept any liability related to any default, damage, costs or problem which is based on any weakness or default in the customer's applications or products, or the application or use by customer's third party customer(s). Customer is responsible for doing all necessary testing for the customer's applications and products using NXP Semiconductors products in order to avoid a default of the applications and the products or of the application or use by customer's third party customer(s). NXP does not accept any liability in this respect.

Limiting values — Stress above one or more limiting values (as defined in the Absolute Maximum Ratings System of IEC 60134) will cause permanent damage to the device. Limiting values are stress ratings only and (proper) operation of the device at these or any other conditions above those given in the Recommended operating conditions section (if present) or the Characteristics sections of this document is not warranted. Constant or repeated exposure to limiting values will permanently and irreversibly affect the quality and reliability of the device.

Terms and conditions of commercial sale — NXP Semiconductors products are sold subject to the general terms and conditions of commercial sale, as published at <http://www.nxp.com/profile/terms>, unless otherwise agreed in a valid written individual agreement. In case an individual agreement is concluded only the terms and conditions of the respective agreement shall apply. NXP Semiconductors hereby expressly objects to applying the customer's general terms and conditions with regard to the purchase of NXP Semiconductors products by customer.

No offer to sell or license — Nothing in this document may be interpreted or construed as an offer to sell products that is open for acceptance or the grant, conveyance or implication of any license under any copyrights, patents or other industrial or intellectual property rights.

Export control — This document as well as the item(s) described herein may be subject to export control regulations. Export might require a prior authorization from competent authorities.

Translations — A non-English (translated) version of a document is for reference only. The English version shall prevail in case of any discrepancy between the translated and English versions.

19.4 Trademarks

Notice: All referenced brands, product names, service names and trademarks are the property of their respective owners.

20. Contact information

For more information, please visit: <http://www.nxp.com>

For sales office addresses, please send an email to: salesaddresses@nxp.com

21. Contents

1	General description	1	6.7	CAN fail-safe features	21
2	Features and benefits	1	6.7.1	TXD dominant timeout	21
2.1	General	1	6.7.2	Pull-up on TXD pin	21
2.2	Designed for automotive applications	1	6.7.3	V1 undervoltage event	21
2.3	Low-drop voltage regulator for 5 V microcontroller supply (V1)	2	6.7.4	Loss of power at pin BAT	21
2.4	Power Management	2	6.8	Wake-up and interrupt event diagnosis via pin RXD	21
2.5	System control and diagnostic features	2	6.8.1	Interrupt/wake-up delay	22
3	Ordering information	2	6.8.2	Event status and event capture registers	23
4	Block diagram	3	6.9	Non-volatile SBC configuration	25
5	Pinning information	4	6.9.1	Programming MTPNV cells	25
5.1	Pinning	4	6.9.1.1	Calculating the CRC value for MTP programming	26
5.2	Pin description	4	6.9.2	Restoring factory preset values	27
6	Functional description	5	6.10	Device ID	27
6.1	System controller	5	6.11	Lock control register	28
6.1.1	Operating modes	5	6.12	General purpose memory	28
6.1.1.1	Normal mode	5	6.13	SPI	29
6.1.1.2	Standby mode	5	6.13.1	Introduction	29
6.1.1.3	Reset mode	6	6.13.2	Register map	31
6.1.1.4	Off mode	7	6.13.3	Register configuration in UJA1164A operating modes	32
6.1.1.5	Overtemp mode	7	7	Limiting values	34
6.1.1.6	Forced Normal mode	7	8	Thermal characteristics	35
6.1.1.7	Hardware characterization for the UJA1164A operating modes	8	9	Static characteristics	35
6.1.2	System control registers	8	10	Dynamic characteristics	40
6.2	Watchdog	9	11	Application information	45
6.2.1	Software Development mode	12	11.1	Application diagram	45
6.2.2	Watchdog behavior in Window mode	12	11.2	Application hints	45
6.2.3	Watchdog behavior in Timeout mode	12	12	Test information	46
6.2.4	Watchdog behavior in Autonomous mode	12	12.1	Quality information	46
6.3	System reset	13	13	Package outline	47
6.3.1	Characteristics of pin RSTN	13	14	Handling information	48
6.3.2	Selecting the output reset pulse width	13	15	Soldering of SMD packages	48
6.3.3	Reset sources	14	15.1	Introduction to soldering	48
6.4	Global temperature protection	14	15.2	Wave and reflow soldering	48
6.5	Power supplies	14	15.3	Wave soldering	48
6.5.1	Battery supply voltage (V _{BAT})	14	15.4	Reflow soldering	49
6.5.2	Low-drop voltage supply for 5 V microcontroller (V1)	15	16	Soldering of HVSON packages	50
6.6	High-speed CAN transceiver	15	17	Appendix: ISO 11898-2:201x parameter cross-reference list	51
6.6.1	CAN operating modes	16	18	Revision history	53
6.6.1.1	CAN Active mode	16	19	Legal information	54
6.6.1.2	CAN Listen-only mode	17	19.1	Data sheet status	54
6.6.1.3	CAN Offline and Offline Bias modes	17	19.2	Definitions	54
6.6.1.4	CAN Off mode	18			
6.6.2	CAN standard wake-up	19			
6.6.3	CAN control and Transceiver status registers	20			

continued >>

19.3 Disclaimers 54
19.4 Trademarks 55
20 Contact information 55
21 Contents 56

Please be aware that important notices concerning this document and the product(s) described herein, have been included in section 'Legal information'.

© NXP Semiconductors N.V. 2019. All rights reserved.

For more information, please visit: <http://www.nxp.com>
For sales office addresses, please send an email to: salesaddresses@nxp.com

Date of release: 23 August 2019
Document identifier: UJA1164A