

UJA1163A

Mini high-speed CAN system basis chip with Standby mode

Rev. 1 — 23 August 2019

Product data sheet

1. General description

The UJA1163A is a mini high-speed CAN System Basis Chip (SBC) containing an ISO 11898-2:2016 and SAE J2284-1 to SAE J2284-5 compliant HS-CAN transceiver and an integrated 5 V/100 mA supply for a microcontroller. The UJA1163A can be operated in very-low-current Standby mode with bus wake-up capability and supports ISO 11898-6 compliant autonomous CAN biasing.

This implementation enables reliable communication in the CAN FD fast phase at data rates up to 5 Mbit/s.

2. Features and benefits

2.1 General

- ISO 11898-2:2016 and SAE J2284-1 to SAE J2284-5 compliant high-speed CAN transceiver
- Hardware and software compatible with the UJA116x product family and with improved EMC performance
- Loop delay symmetry timing enables reliable communication at data rates up to 5 Mbit/s in the CAN FD fast phase
- Autonomous bus biasing according to ISO 11898-6
- Fully integrated 5 V/100 mA low-drop voltage regulator for 5 V microcontroller supply (V1)
- Bus connections are truly floating when power to pin BAT is off

2.2 Designed for automotive applications

- ± 8 kV ElectroStatic Discharge (ESD) protection, according to the Human Body Model (HBM) on the CAN bus pins
- ± 6 kV ESD protection, according to IEC TS 62228 on the CAN bus pins and on pin BAT
- CAN bus pins short-circuit proof to ± 58 V
- Battery and CAN bus pins protected against automotive transients according to ISO 7637-3
- Very low quiescent current in Standby mode with full wake-up capability
- Leadless HVSON14 package (3.0 mm \times 4.5 mm) with improved Automated Optical Inspection (AOI) capability and low thermal resistance
- Dark green product (halogen free and Restriction of Hazardous Substances (RoHS) compliant)



2.3 Low-drop voltage regulator for 5 V microcontroller supply (V1)

- 5 V nominal output; ±2 % accuracy
- 100 mA output current capability
- Current limiting above 150 mA
- On-resistance of 5 Ω (max)
- Support for microcontroller RAM retention down to a battery voltage of 2 V
- Undervoltage reset at 90 % of nominal value
- Excellent transient response with a 4.7 μF ceramic output capacitor
- Short-circuit to GND/overload protection on pin V1

2.4 Power Management

- Standby mode featuring very low supply current; voltage V1 remains active to maintain the supply to the microcontroller
- Remote wake-up capability via standard CAN wake-up pattern

2.5 System control and diagnostic features

- Mode control via pin STBN
- Overtemperature shutdown
- Bidirectional reset pin

3. Ordering information

Table 1. Ordering information

Type number	Package		
	Name	Description	Version
UJA1163ATK	HVSON14	plastic thermal enhanced very thin small outline package; no leads; 14 terminals; body 3 × 4.5 × 0.85 mm	SOT1086-2

4. Block diagram

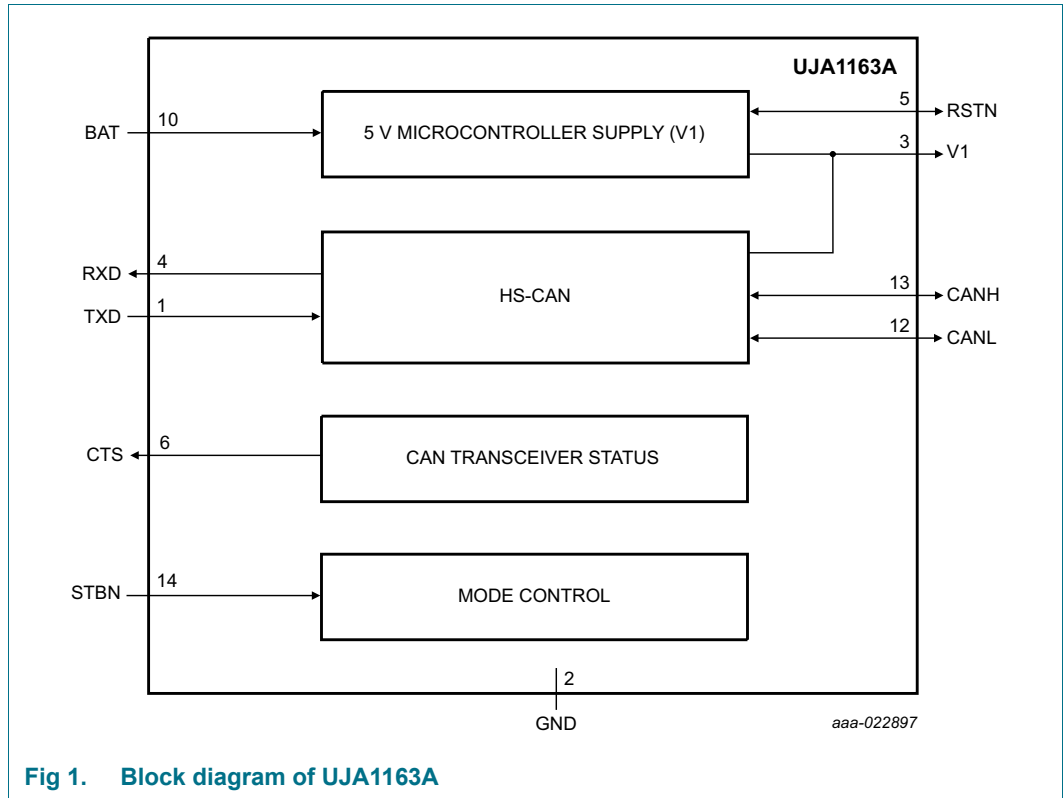

Fig 1. Block diagram of UJA1163A

5. Pinning information

5.1 Pinning

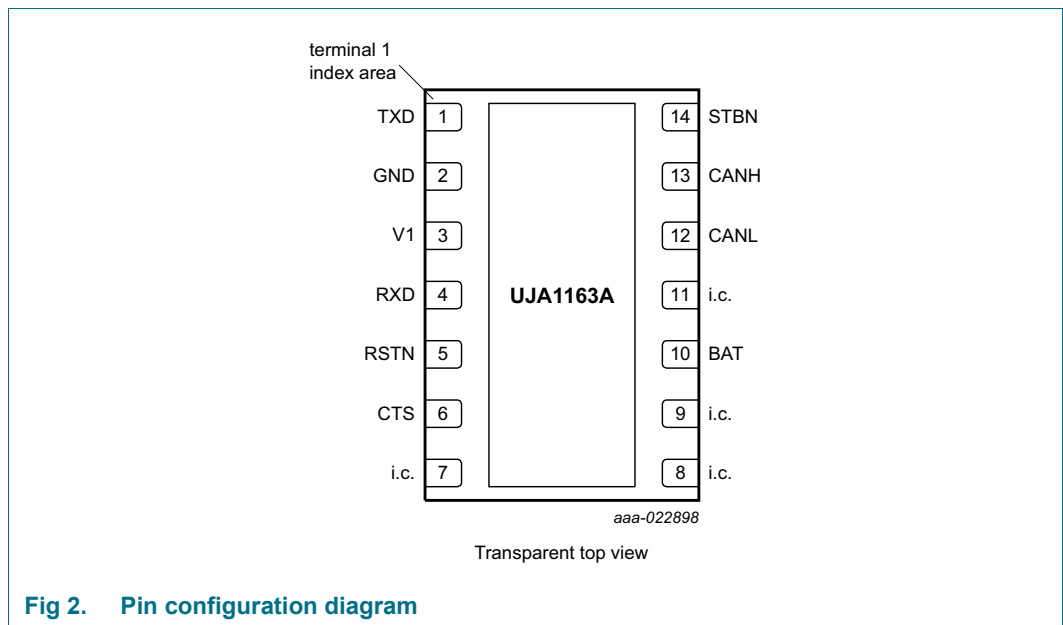

Fig 2. Pin configuration diagram

5.2 Pin description

Table 2. Pin description

Symbol	Pin	Description
TXD	1	transmit data input
GND	2 ^[1]	ground
V1	3	5 V microcontroller supply voltage
RXD	4	receive data output; reads out data from the bus lines
RSTN	5	reset input/output
CTS	6	CAN transceiver status output
i.c.	7	internally connected; should be left floating or connected to GND
i.c.	8	internally connected; should be left floating or connected to GND
i.c.	9	internally connected; should be left floating or connected to GND
BAT	10	battery supply voltage
i.c.	11	internally connected; should be left floating or connected to GND
CANL	12	LOW-level CAN bus line
CANH	13	HIGH-level CAN bus line
STBN	14	standby control input (active LOW)

[1] The exposed die pad at the bottom of the package allows for better heat dissipation and grounding from the SBC via the printed circuit board. For enhanced thermal and electrical performance, it is recommended to solder the exposed die pad to GND.

6. Functional description

6.1 System controller

The system controller controls the internal functions of the UJA1163A.

6.1.1 Operating modes

The system controller contains a state machine that supports five operating modes: Normal, Standby, Reset, Overtemp and Off. The state transitions are illustrated in [Figure 3](#).

6.1.1.1 Normal mode

Normal mode is the active operating mode. In this mode, all the hardware on the device is available and can be activated (see [Table 3](#)). Voltage regulator V1 is enabled to supply the microcontroller.

The CAN interface can be configured to be active and thus to support normal CAN communication.

Normal mode can be selected from Standby mode by setting pin STBN HIGH. Pending wake-up events (power-on, CAN bus wake-up) are cleared when the UJA1163A enters Normal mode.

6.1.1.2 Standby mode

Standby mode is the power saving mode of the UJA1163A, offering reduced current consumption. The transceiver is unable to transmit or receive data in Standby mode. V1 remains active.

The receiver monitors bus activity for a wake-up request. The bus pins are biased to GND (via $R_{i(cm)}$) when the bus is inactive for $t > t_{to(silence)}$ and at approximately 2.5 V when there is activity on the bus (autonomous biasing).

Pin RXD is forced LOW when a wake-up event is detected on the CAN bus.

The UJA1163A switches to Standby mode via Reset mode:

- from Off mode if the battery voltage rises above the power-on detection threshold ($V_{th(det)pon}$)
- from Overtemp mode if the chip temperature falls below the overtemperature protection release threshold, $T_{th(rel)otp}$

Standby mode can also be selected from Normal by setting pin STBN LOW.

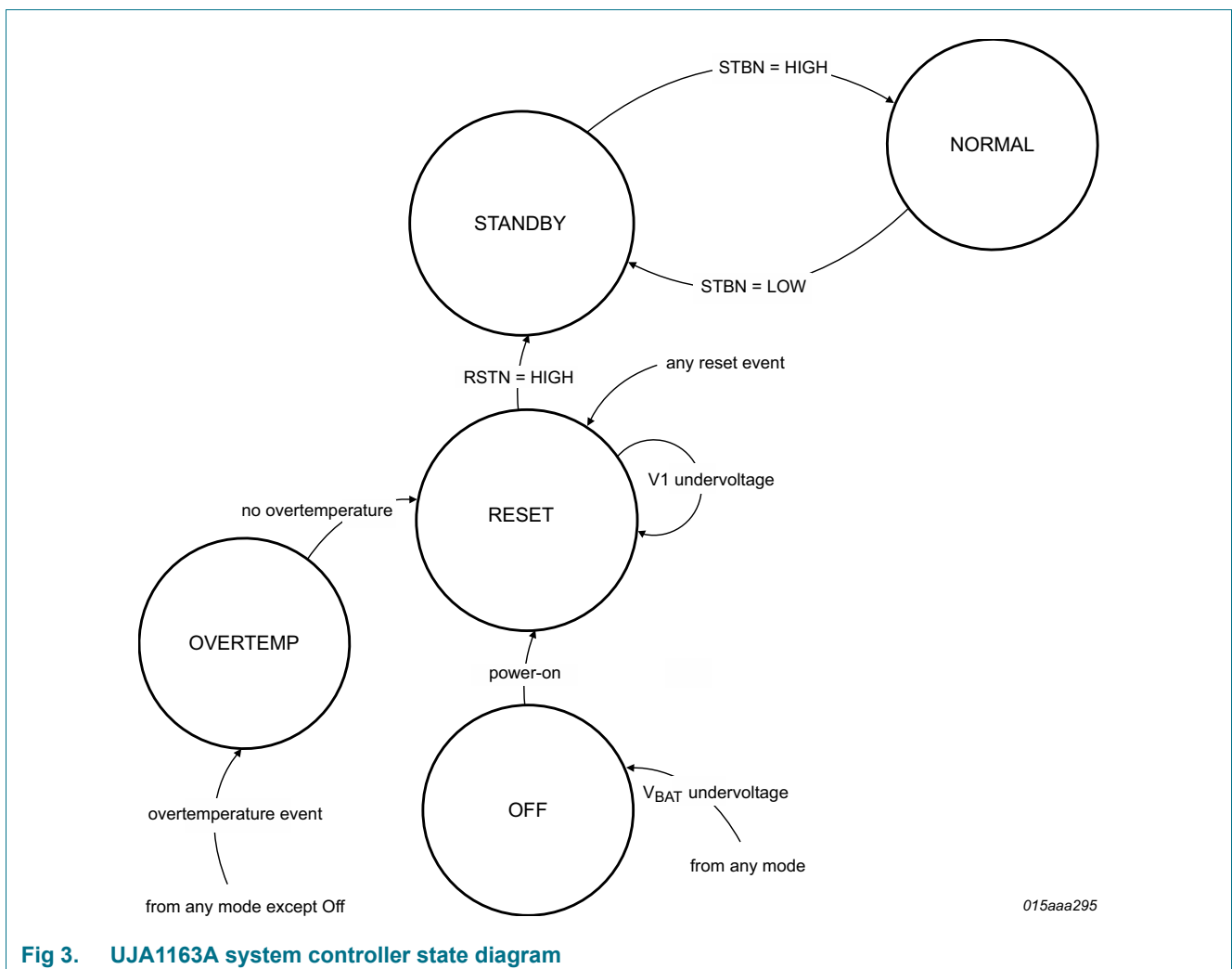

Fig 3. UJA1163A system controller state diagram

6.1.1.3 Reset mode

Reset mode is the reset execution state of the SBC. This mode ensures that pin RSTN is pulled down for a defined time to allow the microcontroller to start up in a controlled manner.

The transceiver is unable to transmit or receive data in Reset mode. V1 and overtemperature detection are active.

The UJA1163A switches to Reset mode from any mode in response to a reset event.

The UJA1163A exits Reset mode:

- and switches to Standby mode if pin RSTN is released HIGH
- if the SBC is forced into Off or Overtemp mode

If a V1 undervoltage event forced the transition to Reset mode, the UJA1163A will remain in Reset mode until the voltage on pin V1 has recovered.

6.1.1.4 Off mode

The UJA1163A switches to Off mode when the battery is first connected or from any mode when $V_{BAT} < V_{th(det)poff}$. Only power-on detection is enabled; all other modules are inactive. The UJA1163A starts to boot up when the battery voltage rises above the power-on detection threshold $V_{th(det)pon}$ (triggering an initialization process) and switches to Reset mode after $t_{startup}$. Pin RXD is driven LOW when the UJA1163A switches from Off mode to Standby mode, to indicate a power-on event has occurred.

In Off mode, the CAN pins disengage from the bus (zero load; high-ohmic).

6.1.1.5 Overtemp mode

Overtemp mode is provided to prevent the UJA1163A being damaged by excessive temperatures. The UJA1163A switches immediately to Overtemp mode from any mode (other than Off mode) when the global chip temperature rises above the overtemperature protection activation threshold, $T_{th(act)otp}$.

In Overtemp mode, the CAN transmitter and receiver are disabled and the CAN pins are in a high-ohmic state. No wake-up event will be detected, but a pending wake-up will still be signalled by a LOW level on pin RXD, which will persist after the overtemperature event has been cleared. V1 is off and pin RSTN is driven LOW.

The UJA1163A exits Overtemp mode:

- and switches to Reset mode if the chip temperature falls below the overtemperature protection release threshold, $T_{th(rel)otp}$
- if the device is forced to switch to Off mode ($V_{BAT} < V_{th(det)poff}$)

6.1.1.6 Hardware characterization for the UJA1163A operating modes

Table 3. Hardware characterization by functional block

Block	Operating mode				
	Off	Standby	Normal	Reset	Overtemp
V1	off ^[1]	on	on	on	off
RSTN	LOW	HIGH	HIGH	LOW	LOW
CAN	off	Offline	Active	Offline	off
RXD	V ₁ level	V ₁ level/LOW if wake-up detected	CAN bit stream	V ₁ level/LOW if wake-up detected	V ₁ level/LOW if wake-up detected

[1] When the SBC switches from Reset, Standby or Normal mode to Off mode, V1 behaves as a current source during power down while V_{BAT} is between 3 V and 2V.

6.1.2 Mode control via pin STBN

The UJA1163A can be switched between Normal and Standby modes via the STBN control input (see Figure 3). When STBN goes LOW, the UJA1163A switches to Standby mode. When STBN goes HIGH, the UJA1163A switches to Normal mode.

6.2 System reset

When a system reset occurs, the SBC switches to Reset mode and initiates a process that generates a low-level pulse on pin RSTN.

6.2.1 Characteristics of pin RSTN

Pin RSTN is a bidirectional open drain low side driver with integrated pull-up resistance, as shown in Figure 4. With this configuration, the SBC can detect the pin being pulled down externally, e.g. by the microcontroller. The input reset pulse width must be at least $t_{w(rst)}$.

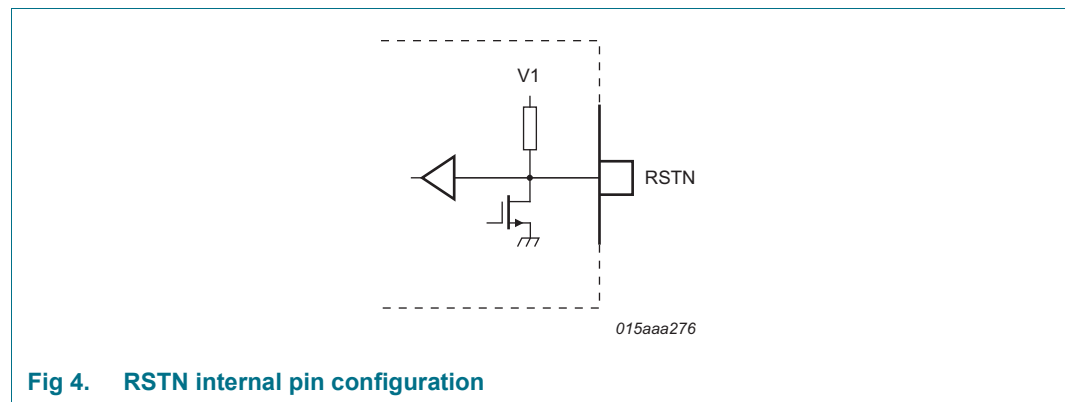

Fig 4. RSTN internal pin configuration

6.2.2 Output reset pulse width

The SBC distinguishes between a cold start and a warm start. A cold start is performed on start-up if the reset event was combined with a V1 undervoltage event (power-on reset, overtemperature reset, V1 undervoltage before entering or while in Reset mode). The cold start output reset pulse width ($t_{w(rst)}$) is between 20 ms and 25 ms.

If the reset event was triggered externally (by pulling RSTN LOW), the output reset pulse is between 1 ms and 1.5 ms. This is called warm start of the microcontroller.

6.2.3 Reset sources

The following events will cause the UJA1163A to switch to Reset mode:

- V_{V1} drops below the 90 % undervoltage threshold
- pin RSTN is pulled down externally
- the SBC leaves Off mode
- the SBC leaves Overtemp mode

6.3 Global temperature protection

The temperature of the UJA1163A is monitored continuously, except in Off mode. The SBC switches to Overtemp mode if the temperature exceeds the overtemperature protection activation threshold, $T_{th(act)otp}$. In addition, pin RSTN is driven LOW and V1 and the CAN transceiver are switched off. When the temperature drops below the overtemperature protection release threshold, $T_{th(rel)otp}$, the SBC switches to Standby mode via Reset mode.

6.4 Power supplies

6.4.1 Battery supply voltage (V_{BAT})

The internal circuitry is supplied from the battery via pin BAT. The device needs to be protected against negative supply voltages, e.g. by using an external series diode. If V_{BAT} falls below the power-off detection threshold, $V_{th(det)poff}$, the SBC switches to Off mode. However, the microcontroller supply voltage (V1) remains active until V_{BAT} falls below 2 V.

The SBC switches from Off mode to Reset mode $t_{startup}$ after the battery voltage rises above the power-on detection threshold, $V_{th(det)pon}$. A power-on event is indicated by a LOW level on pin RXD. RXD remains LOW from the moment UJA1163A exits Off mode until it switches to Normal mode.

6.4.2 Low-drop voltage supply for 5 V microcontroller (V1)

V1 is intended to supply the microcontroller and the internal CAN transceiver and delivers up to 150 mA at 5 V. The output voltage on V1 is monitored. A system reset is generated if the voltage on V1 drops below the 90 % undervoltage threshold (90 % of the nominal V1 output voltage).

The internal CAN transceiver consumes 50 mA (max) when the bus is continuously dominant, leaving 100 mA available for the external load on pin V1. In practice, the typical current consumption of the CAN transceiver is lower (≈ 25 mA), depending on the application, leaving more current available for the load.

6.5 High-speed CAN transceiver

The integrated high-speed CAN transceiver is designed for active communication at bit rates up to 1 Mbit/s, providing differential transmit and receive capability to a CAN protocol controller. The transceiver is ISO 11898-2:2016 compliant. The CAN transmitter is supplied from V1. The UJA1163A includes additional timing parameters on loop delay symmetry to ensure reliable communication in fast phase at data rates up to 5 Mbit/s, as used in CAN FD networks.

The CAN transceiver supports autonomous CAN biasing, which helps to minimize RF emissions. CANH and CANL are always biased to 2.5 V when the UJA1163A is in Normal mode. Autonomous biasing is active when the UJA1163A is in Standby mode and the CAN transceiver is in CAN Offline mode - to 2.5 V if there is activity on the bus (CAN Offline Bias mode) and to GND if there is no activity on the bus for $t > t_{to(silence)}$ (CAN Offline mode).

This is useful when the node is disabled due to a malfunction in the microcontroller. The SBC ensures that the CAN bus is correctly biased to avoid disturbing ongoing communication between other nodes. The autonomous CAN bias voltage is derived directly from V_{BAT} .

6.5.1 CAN operating modes

The integrated CAN transceiver supports three operating modes: Active, Offline and Offline Bias (see [Figure 6](#)). The CAN transceiver operating mode depends on the UJA1163A operating mode and the output voltage on V1.

6.5.1.1 CAN Active mode

In CAN Active mode, the transceiver can transmit and receive data via CANH and CANL. The differential receiver converts the analog data on the bus lines into digital data, which is output on pin RXD. The transmitter converts digital data generated by the CAN controller (input on pin TXD) into analog signals suitable for transmission over the CANH and CANL bus lines.

The CAN transceiver is in Active mode when:

- the UJA1163A is in Normal mode (STBN = 1) AND
- the voltage on pin V1 is above the 90 % threshold

If pin TXD is LOW when the transceiver switches to CAN Active mode (UJA1163A in Normal mode), the transmitter and receiver will remain disabled until TXD goes HIGH. This prevents network traffic being blocked for $t_{to(dom)TXD}$ (i.e. while the TXD dominant time-out timer is running; see [Section 6.7.1](#)) every time the transceiver enters Active mode, if the TXD pin is clamped permanently LOW.

In CAN Active mode, the CAN bias voltage is derived from V1.

6.5.1.2 CAN Offline and Offline Bias modes

In CAN Offline mode, the transceiver monitors the CAN bus for a wake-up event. CANH and CANL are biased to GND.

CAN Offline Bias mode is the same as CAN Offline mode, with the exception that the CAN bus is biased to 2.5 V. This mode is activated automatically when activity is detected on the CAN bus while the transceiver is in CAN Offline mode. The transceiver will return to CAN Offline mode if the CAN bus is silent (no CAN bus edges) for longer than $t_{to(silence)}$.

The CAN transceiver switches to CAN Offline mode from CAN Active mode if:

- the SBC switches to Reset or Standby mode

provided the CAN-bus has been inactive for at least $t_{to(silence)}$. If the CAN-bus has been inactive for less than $t_{to(silence)}$, the CAN transceiver switches first to CAN Offline Bias mode and then to CAN Offline mode once the bus has been silent for $t_{to(silence)}$.

The CAN transceiver switches to CAN Offline Bias mode from CAN Active mode if the voltage on V1 drops below the 90 % undervoltage threshold.

The CAN transceiver switches to CAN Offline mode:

- from CAN Offline Bias mode if no activity is detected on the bus (no CAN edges) for $t > t_{to(silence)}$ OR
- when the SBC switches from Off or Overtemp mode to Reset mode

The CAN transceiver switches from CAN Offline mode to CAN Offline Bias mode if:

- a standard wake-up pattern is detected on the CAN bus OR
- the SBC is in Normal mode with $V_{V1} < 90\%$

6.5.1.3 CAN Off mode

The CAN transceiver is switched off completely with the bus lines floating when:

- the SBC switches to Off or Overtemp mode OR
- V_{BAT} falls below the CAN receiver undervoltage detection threshold, $V_{uvd(CAN)}$

It will be switched on again on entering CAN Offline mode when V_{BAT} rises above the undervoltage recovery threshold ($V_{uvr(CAN)}$) and the SBC is no longer in Off/Overtemp mode. CAN Off mode prevents reverse currents flowing from the bus when the battery supply to the SBC is lost.

6.5.2 CAN standard wake-up

The UJA1163A monitors the bus for a wake-up pattern when the CAN transceiver is in Offline mode.

A filter at the receiver input prevents unwanted wake-up events occurring due to automotive transients or EMI. A dominant-recessive-dominant wake-up pattern must be transmitted on the CAN bus within the wake-up timeout time ($t_{to(wake)}$) to pass the wake-up filter and trigger a wake-up event (see [Figure 5](#); note that additional pulses may occur between the recessive/dominant phases). The recessive and dominant phases must last at least $t_{wake(busrec)}$ and $t_{wake(busdom)}$, respectively.

Pin RXD is driven LOW when a valid CAN wake-up pattern is detected on the bus.

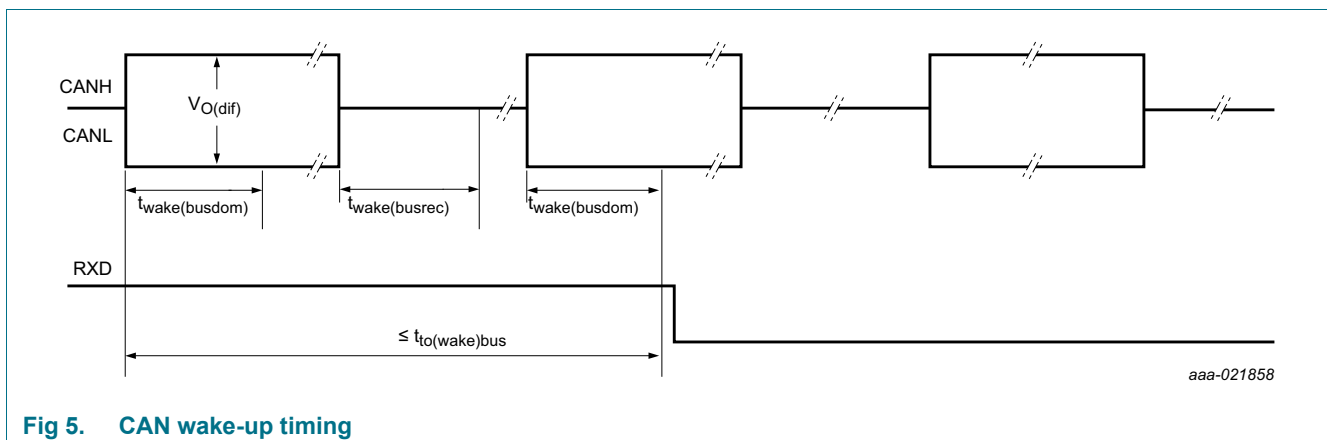

Fig 5. CAN wake-up timing

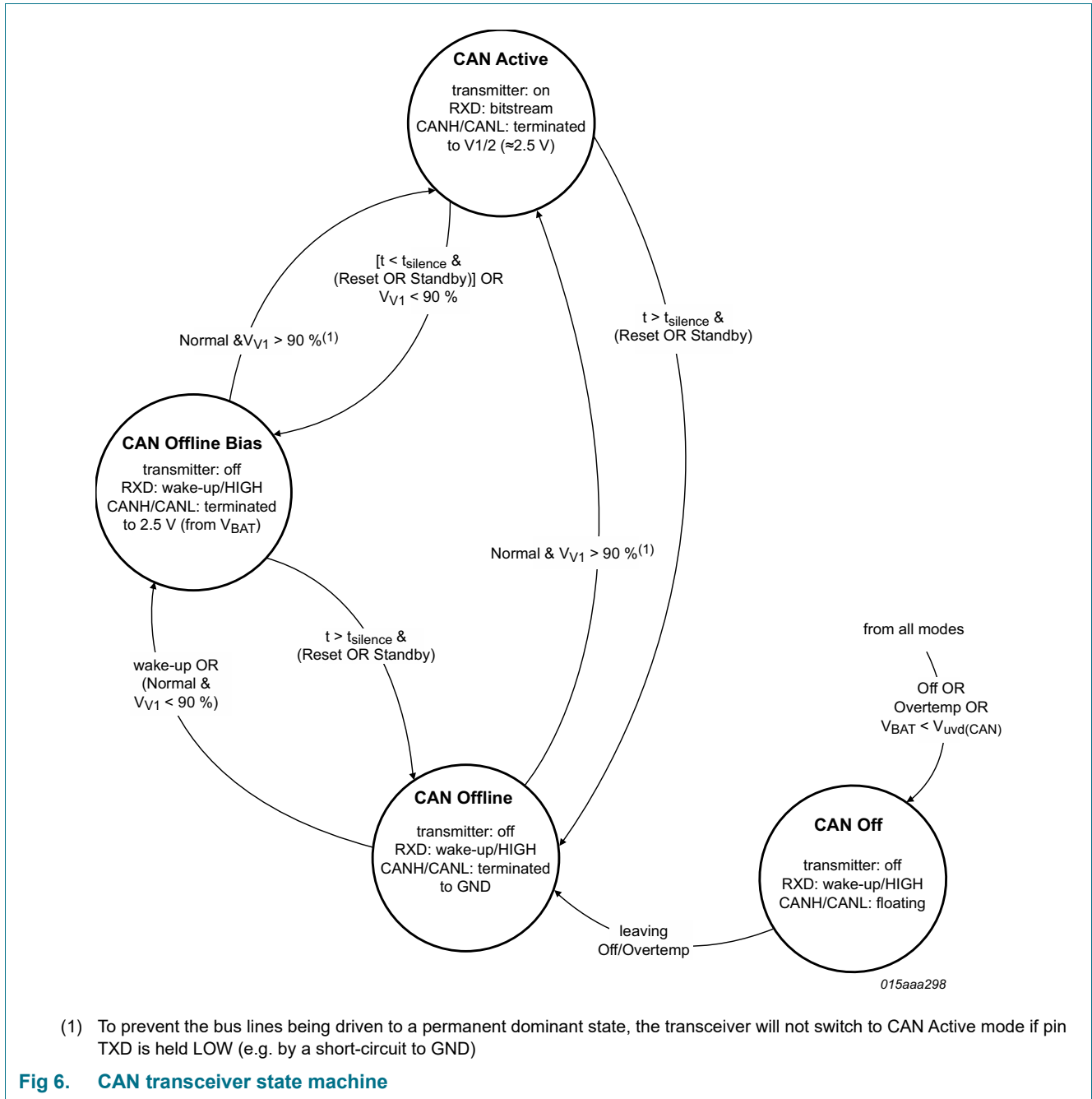

Fig 6. CAN transceiver state machine

6.6 CAN transceiver status pin (CTS)

Pin CTS is driven HIGH to indicate to microcontroller that the transceiver is fully enabled and data can be transmitted and received via the TXD/RXD pins.

Pin CTS is actively driven LOW:

- while the transceiver is starting up (e.g. during a transition from Standby to Normal) or
- if pin TXD is clamped LOW for $t > t_{\text{to(dom)TXD}}$ OR
- if an undervoltage is detected on V1

6.7 CAN fail-safe features

6.7.1 TXD dominant timeout

A TXD dominant time-out timer is started when pin TXD is forced LOW while the transceiver is in CAN Active Mode. If the LOW state on pin TXD persists for longer than the TXD dominant time-out time ($t_{to(dom)TXD}$), the transmitter is disabled, releasing the bus lines to recessive state. This function prevents a hardware and/or software application failure from driving the bus lines to a permanent dominant state (blocking all network communications). The TXD dominant time-out timer is reset when pin TXD goes HIGH. The TXD dominant time-out time also defines the minimum possible bit rate of 4.4 kbit/s.

6.7.2 Pull-up on TXD pin

Pin TXD has an internal pull-up towards V1 to ensure a safe defined recessive driver state in case the pin is left floating.

6.7.3 Pull-down on STBN pin

Pin STBN has an internal pull-down (to GND) to ensure the UJA1163A switches to Standby mode if STBN is left floating.

6.7.4 Loss of power at pin BAT

A loss of power at pin BAT has no influence on the bus lines or on the microcontroller. No reverse currents will flow from the bus.

7. Limiting values

Table 4. Limiting values

In accordance with the Absolute Maximum Rating System (IEC 60134).

Symbol	Parameter	Conditions	Min	Max	Unit
V _x	voltage on pin x ^[1]	pin V1 ^[2]	-0.2	+6	V
		pins TXD, RXD, RSTN, CTS, STBN ^[3]	-0.2	V _{V1} + 0.2	V
		pin BAT	-0.2	+40	V
		pins CANH and CANL with respect to any other pin	-58	+58	V
V _(CANH-CANL)	voltage between pin CANH and pin CANL		-40	+40	V
V _{trt}	transient voltage	on pins CANL, CANH, WAKE, BAT ^[4]			
		pulse 1	-100	-	V
		pulse 2a	-	75	V
		pulse 3a	-150	-	V
		pulse 3b	-	100	V
V _{ESD}	electrostatic discharge voltage	IEC 61000-4-2 (150 pF, 330 Ω) discharge circuit ^[5]			
		on pins CANH and CANL; pin BAT with capacitor	-6	+6	kV
		Human Body Model (HBM)			
		on any pin ^[6]	-2	+2	kV
		on pin BAT ^[7]	-4	+4	kV
		on pins CANH, CANL ^[8]	-8	+8	kV
		Machine Model (MM) ^[9]			
		on any pin	-100	+100	V
		Charged Device Model (CDM) ^[10]			
		on corner pins	-750	+750	V
on any other pin	-500	+500	V		
T _{vj}	virtual junction temperature	^[11]	-40	+150	°C
T _{stg}	storage temperature		-55	+150	°C

- [1] The device can sustain voltages up to the specified values over the product lifetime, provided applied voltages (including transients) never exceed these values.
- [2] When the device is not powered up, I_{V1} (max) = 25 mA.
- [3] Maximum voltage should never exceed 6 V.
- [4] Verified by an external test house according to IEC TS 62228, Section 4.2.4; parameters for standard pulses defined in ISO7637 part 2.
- [5] Verified by an external test house according to IEC TS 62228, Section 4.3.
- [6] According to AEC-Q100-002.
- [7] Pins stressed to reference group containing all grounds, emulating the application circuit (Figure 10). HBM pulse as specified in AEC-Q100-002 used.
- [8] Pins stressed to reference group containing all ground and supply pins, emulating the application circuit (Figure 10). HBM pulse as specified in AEC-Q100-002 used.
- [9] According to AEC-Q100-003.
- [10] According to AEC-Q100-011.
- [11] In accordance with IEC 60747-1. An alternative definition of virtual junction temperature is: T_{vj} = T_{amb} + P × R_{th(j-a)}, where R_{th(j-a)} is a fixed value used in the calculation of T_{vj}. The rating for T_{vj} limits the allowable combinations of power dissipation (P) and ambient temperature (T_{amb}).

8. Thermal characteristics

Table 5. Thermal characteristics

Symbol	Parameter	Conditions	Typ	Unit
$R_{th(vj-a)}$	thermal resistance from virtual junction to ambient		[1] 60	K/W

[1] According to JEDEC JESD51-2, JESD51-5 and JESD51-7 at natural convection on 2s2p board. Board with two inner copper layers (thickness: 35 μm) and thermal via array under the exposed pad connected to the first inner copper layer (thickness: 70 μm).

9. Static characteristics

Table 6. Static characteristics

$T_{vj} = -40\text{ }^{\circ}\text{C}$ to $+150\text{ }^{\circ}\text{C}$; $V_{BAT} = 3\text{ V}$ to 28 V ; $R_L = R_{(CANH-CANL)} = 60\text{ }\Omega$; all voltages are defined with respect to ground; positive currents flow into the IC; typical values are given at $V_{BAT} = 13\text{ V}$; unless otherwise specified. [\[1\]](#)

Symbol	Parameter	Conditions	Min	Typ	Max	Unit
Supply; pin BAT						
$V_{th(det)pon}$	power-on detection threshold voltage	V_{BAT} rising	4.2	-	4.55	V
$V_{th(det)poff}$	power-off detection threshold voltage	V_{BAT} falling	2.8	-	3	V
$V_{uvr(CAN)}$	CAN undervoltage recovery voltage	V_{BAT} rising	4.5	-	5	V
$V_{uvd(CAN)}$	CAN undervoltage detection voltage	V_{BAT} falling	4.2	-	4.55	V
I_{BAT}	battery supply current	Normal mode; MC = 111; CAN Active mode				
		CAN recessive; $V_{TXD} = V_{V1}$	-	4	7.5	mA
		CAN dominant; $V_{TXD} = 0\text{ V}$	-	46	67	mA
		Standby mode; $I_{V1} = 0\text{ }\mu\text{A}$; $-40\text{ }^{\circ}\text{C} < T_{vj} < 85\text{ }^{\circ}\text{C}$; $V_{BAT} = 7\text{ V}$ to 18 V	-	[2]	91	μA
Voltage source: pin V1						
V_O	output voltage	$V_{BAT} = 5.5\text{ V}$ to 28 V ; $V_{TXD} = V_{V1}$; $I_{V1} = -120\text{ mA}$ to 0 mA	4.9	5	5.1	V
		$V_{BAT} = 5.65\text{ V}$ to 28 V ; $V_{TXD} = V_{V1}$; $I_{V1} = -150\text{ mA}$ to 0 mA	4.9	5	5.1	V
		$V_{BAT} = 5.65\text{ V}$ to 28 V ; $I_{V1} = -100\text{ mA}$ to 0 mA ; $V_{TXD} = 0\text{ V}$; $V_{CANH} = 0\text{ V}$	4.9	5	5.1	V
$\Delta V_{ret(RAM)}$	RAM retention voltage difference	$V_{BAT} = 2\text{ V}$ to 3 V ; $I_{V1} = -2\text{ mA}$	-	-	100	mV
		$V_{BAT} = 2\text{ V}$ to 3 V ; $I_{V1} = -200\text{ }\mu\text{A}$			10	mV
$R_{(BAT-V1)}$	resistance between pin BAT and pin V1	$V_{BAT} = 4\text{ V}$ to 6 V ; $I_{V1} = -120\text{ mA}$; $T_{vj} < 150\text{ }^{\circ}\text{C}$	-	-	5	Ω
		$V_{BAT} = 3\text{ V}$ to 4 V ; $I_{V1} = -40\text{ mA}$	-	2.625	-	Ω
V_{uvd}	undervoltage detection voltage	$V_{uvd(nom)} = 90\text{ }\%$	4.5	-	4.75	V
V_{uvr}	undervoltage recovery voltage		4.5	-	4.75	V
$I_{O(sc)}$	short-circuit output current		-300	-	-150	mA

Table 6. Static characteristics ...continued

$T_{vj} = -40\text{ °C to }+150\text{ °C}$; $V_{BAT} = 3\text{ V to }28\text{ V}$; $R_L = R_{(CANH-CANL)} = 60\ \Omega$; all voltages are defined with respect to ground; positive currents flow into the IC; typical values are given at $V_{BAT} = 13\text{ V}$; unless otherwise specified. [1]

Symbol	Parameter	Conditions	Min	Typ	Max	Unit
$I_{CAN(int)V1}$	internal CAN supply current from V1	Normal mode; CAN Active mode; CAN dominant; $V_{TXD} = 0\text{ V}$; short-circuit on bus lines; $-3\text{ V} < (V_{CANH} = V_{CANL}) < +18\text{ V}$	-	-	59	mA
Standby mode control input; pin STBN						
$V_{th(sw)}$	switching threshold voltage		$0.25V_{V1}$	-	$0.75V_{V1}$	V
R_{pd}	pull-down resistance		40	60	80	k Ω
CAN transmit data input; pin TXD						
$V_{th(sw)}$	switching threshold voltage		$0.25V_{V1}$	-	$0.75V_{V1}$	V
$V_{th(sw)hys}$	switching threshold voltage hysteresis		$0.05V_{V1}$	-	-	V
R_{pu}	pull-up resistance		40	60	80	k Ω
CAN transmitter status; pin CTS						
I_{OH}	HIGH-level output current	$V_{CTS} = V_{V1} - 0.4\text{ V}$; transmitter on	-	-	-4	mA
I_{OL}	LOW-level output current	$V_{CTS} = 0.4\text{ V}$; transmitter off	4	-	-	mA
CAN receive data output; pin RXD						
V_{OH}	HIGH-level output voltage	$I_{OH} = -4\text{ mA}$	$V_{V1} - 0.4$	-	-	V
V_{OL}	LOW-level output voltage	$I_{OL} = 4\text{ mA}$	-	-	0.4	V
R_{pu}	pull-up resistance	CAN Offline mode	40	60	80	k Ω
High-speed CAN bus lines; pins CANH and CANL						
$V_{O(dom)}$	dominant output voltage	CAN Active mode; $V_{TXD} = 0\text{ V}$; $V_{V1} = 4.5\text{ V to }5.5\text{ V}$; $t < t_{to(dom)TXD}$				
		pin CANH; $R_L = 50\ \Omega\text{ to }65\ \Omega$	2.75	3.5	4.5	V
		pin CANL; $R_L = 50\ \Omega\text{ to }65\ \Omega$	0.5	1.5	2.25	V
$V_{dom(TX)sym}$	transmitter dominant voltage symmetry	$V_{dom(TX)sym} = V_{V1} - V_{CANH} - V_{CANL}$; $V_{V1} = 5\text{ V}$	-400	-	+400	mV
V_{TXsym}	transmitter voltage symmetry	$V_{TXsym} = V_{CANH} + V_{CANL}$; $f_{TXD} = 250\text{ kHz, }1\text{ MHz or }2.5\text{ MHz}$; $C_{SPLIT} = 4.7\text{ nF}$	[3] $0.9V_{V1}$	-	$1.1V_{V1}$	V
$V_{O(dif)}$	differential output voltage	CAN Active mode (dominant); $V_{TXD} = 0\text{ V}$; $V_{BAT} > 5.5\text{ V}$; $t < t_{to(dom)TXD}$				
		$R_L = 50\ \Omega\text{ to }65\ \Omega$	1.5	-	3	V
		$R_L = 45\ \Omega\text{ to }70\ \Omega$	1.4	-	3.3	V
		$R_L = 2240\ \Omega$	1.5	-	5	V
		recessive; $R_L = \text{no load}$; $V_{BAT} > 5.5\text{ V}$				
		CAN Active/Offline Bias mode; $V_{TXD} = V_{IO}$	-50	-	+50	mV
		CAN Offline mode	-0.2	-	+0.2	V

Table 6. Static characteristics ...continued

$T_{vj} = -40\text{ }^{\circ}\text{C}$ to $+150\text{ }^{\circ}\text{C}$; $V_{BAT} = 3\text{ V}$ to 28 V ; $R_L = R_{(CANH-CANL)} = 60\ \Omega$; all voltages are defined with respect to ground; positive currents flow into the IC; typical values are given at $V_{BAT} = 13\text{ V}$; unless otherwise specified. [1]

Symbol	Parameter	Conditions	Min	Typ	Max	Unit
$V_{O(rec)}$	recessive output voltage	CAN Active mode; $V_{TXD} = V_{V1}$ $R_L = \text{no load}$	2	$0.5V_{V1}$	3	V
		CAN Offline mode; $R_L = \text{no load}$	-0.1	-	+0.1	V
		CAN Offline Bias mode; $R_L = \text{no load}$	2	2.5	3	V
$I_{O(sc)dom}$	dominant short-circuit output current	CAN Active mode; $V_{BAT} > 5.5\text{ V}$; $V_{TXD} = 0\text{ V}$				
		pin CANH; $V_{CANH} = -3\text{ V}$ to $+27\text{ V}$	-55	-	-	mA
		pin CANL; $V_{CANL} = -15\text{ V}$ to $+18\text{ V}$	-	-	+55	mA
$I_{O(sc)rec}$	recessive short-circuit output current	$V_{CANL} = V_{CANH} = -27\text{ V}$ to $+32\text{ V}$; $V_{TXD} = V_{V1}$	-3	-	+3	mA
$V_{th(RX)dif}$	differential receiver threshold voltage	$-12\text{ V} \leq V_{CANL} \leq +12\text{ V}$; $-12\text{ V} \leq V_{CANH} \leq +12\text{ V}$				
		CAN Active mode	0.5	0.7	0.9	V
		CAN Offline mode	0.4	0.7	1.15	V
$V_{rec(RX)}$	receiver recessive voltage	$-12\text{ V} \leq V_{CANL} \leq +12\text{ V}$; $-12\text{ V} \leq V_{CANH} \leq +12\text{ V}$				
		CAN Active mode	-4 ^[3]	-	+0.5	V
		CAN Offline/Offline Bias modes	-4 ^[3]	-	+0.4	V
$V_{dom(RX)}$	receiver dominant voltage	$-12\text{ V} \leq V_{CANL} \leq +12\text{ V}$; $-12\text{ V} \leq V_{CANH} \leq +12\text{ V}$				
		CAN Active mode	0.9	-	9.0 ^[3]	V
		CAN Offline/Offline Bias modes	1.15	-	9.0 ^[3]	V
$V_{hys(RX)dif}$	differential receiver hysteresis voltage	CAN Active mode; $-12\text{ V} \leq V_{CANL} \leq +12\text{ V}$; $-12\text{ V} \leq V_{CANH} \leq +12\text{ V}$	1	30	60	mV
R_i	input resistance	$-2\text{ V} \leq V_{CANL} \leq +7\text{ V}$; $-2\text{ V} \leq V_{CANH} \leq +7\text{ V}$	9	15	28	k Ω
ΔR_i	input resistance deviation	$0\text{ V} \leq V_{CANL} \leq +5\text{ V}$; $0\text{ V} \leq V_{CANH} \leq +5\text{ V}$	-1	-	+1	%
$R_{i(dif)}$	differential input resistance	$-2\text{ V} \leq V_{CANL} \leq +7\text{ V}$; $-2\text{ V} \leq V_{CANH} \leq +7\text{ V}$	19	30	52	k Ω
$C_{i(cm)}$	common-mode input capacitance		^[3]	-	20	pF
$C_{i(dif)}$	differential input capacitance		^[3]	-	10	pF
I_L	leakage current	$V_{BAT} = V_{V1} = 0\text{ V}$ or $V_{BAT} = V_{V1} =$ shorted to ground via $47\text{ k}\Omega$; $V_{CANH} = V_{CANL} = 5\text{ V}$	-5	-	+5	μA
Temperature protection						
$T_{th(act)otp}$	overtemperature protection activation threshold temperature		167	177	187	$^{\circ}\text{C}$

Table 6. Static characteristics ...continued

$T_{vj} = -40\text{ °C to }+150\text{ °C}$; $V_{BAT} = 3\text{ V to }28\text{ V}$; $R_L = R_{(CANH-CANL)} = 60\ \Omega$; all voltages are defined with respect to ground; positive currents flow into the IC; typical values are given at $V_{BAT} = 13\text{ V}$; unless otherwise specified. [1]

Symbol	Parameter	Conditions	Min	Typ	Max	Unit
$T_{th(rel)otp}$	overtemperature protection release threshold temperature		127	137	147	°C
Reset output; pin RSTN						
V_{OL}	LOW-level output voltage	$V_{V1} = 1.0\text{ V to }5.5\text{ V}$; pull-up resistor to $V_{V1} \geq 900\ \Omega$	0	-	$0.2V_{V1}$	V
R_{pu}	pull-up resistance		40	60	80	k Ω
$V_{th(sw)}$	switching threshold voltage		$0.25V_{V1}$	-	$0.75V_{V1}$	V
$V_{th(sw)hys}$	switching threshold voltage hysteresis		$0.05V_{V1}$	-	-	V

- [1] All parameters are guaranteed over the virtual junction temperature range by design. Factory testing uses correlated test conditions to cover the specified temperature and power supply voltage range.
- [2] See [Figure 7](#).
- [3] Not tested in production; guaranteed by design.
- [4] The test circuit used to measure the bus output voltage symmetry (which includes C_{SPLIT}) is shown in [Figure 12](#).

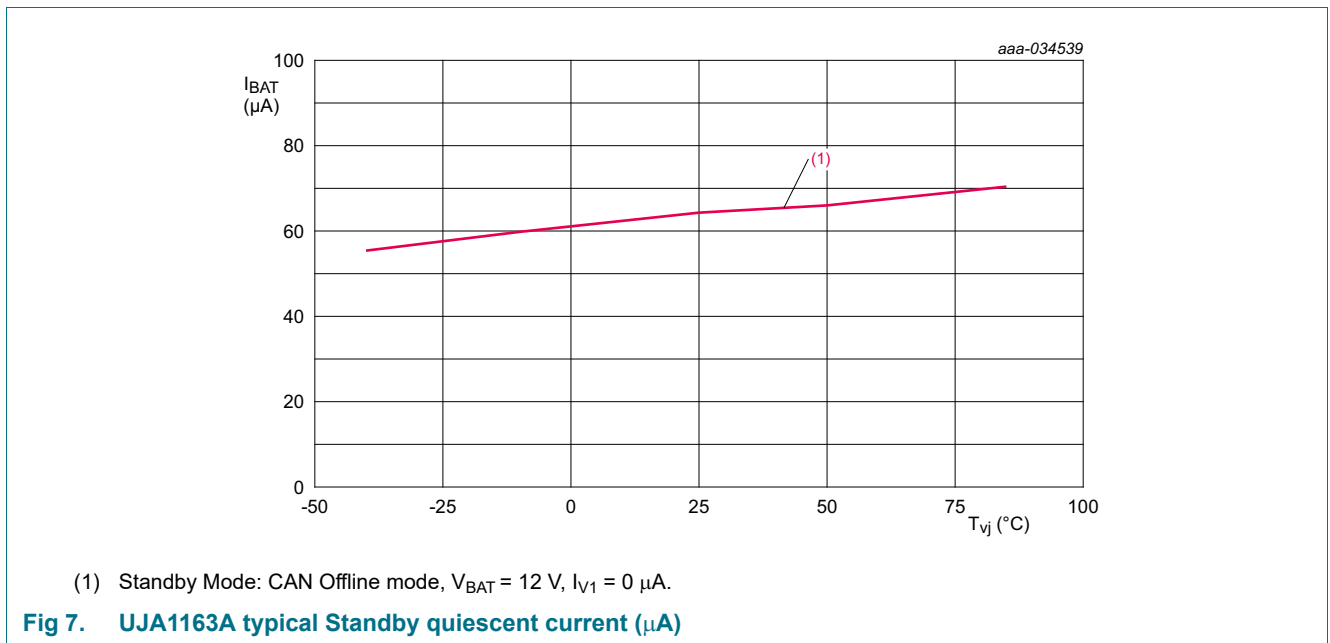

10. Dynamic characteristics

Table 7. Dynamic characteristics

$T_{vj} = -40\text{ °C to }+150\text{ °C}$; $V_{BAT} = 3\text{ V to }28\text{ V}$; $R_L = R_{(CANH-CANL)} = 60\ \Omega$; all voltages are defined with respect to ground; positive currents flow into the IC; typical values are given at $V_{BAT} = 13\text{ V}$; unless otherwise specified. [1]

Symbol	Parameter	Conditions	Min	Typ	Max	Unit
Voltage source; pin V1						
$t_{startup}$	start-up time	from V_{BAT} exceeding the power-on detection threshold until V_{V1} exceeds the 90 % undervoltage threshold; $C_{V1} = 4.7\ \mu\text{F}$	-	2.8	4.7	ms
$t_{d(uvad)}$	undervoltage detection delay time		6	-	54	μs
$t_{d(uvad-RSTNL)}$	delay time from undervoltage detection to RSTN LOW	undervoltage on V1	-	-	63	μs
CAN transceiver timing; pins CANH, CANL, TXD and RXD						
$t_{d(TXD-busdom)}$	delay time from TXD to bus dominant		[2]	-	80	- ns
$t_{d(TXD-busrec)}$	delay time from TXD to bus recessive		[2]	-	80	- ns
$t_{d(busdom-RXD)}$	delay time from bus dominant to RXD		[2]	-	105	- ns
$t_{d(busrec-RXD)}$	delay time from bus recessive to RXD		[2]	-	120	- ns
$t_{d(TXDL-RXDL)}$	delay time from TXD LOW to RXD LOW	$t_{bit(TXD)} = 200\text{ ns}$	[3]	-	-	255 ns
$t_{d(TXDH-RXDH)}$	delay time from TXD HIGH to RXD HIGH	$t_{bit(TXD)} = 200\text{ ns}$	[3]	-	-	255 ns
$t_{bit(bus)}$	transmitted recessive bit width	$t_{bit(TXD)} = 500\text{ ns}$	[4]	435	-	530 ns
		$t_{bit(TXD)} = 200\text{ ns}$	[4]	155	-	210 ns
$t_{bit(RXD)}$	bit time on pin RXD	$t_{bit(TXD)} = 500\text{ ns}$	[4]	400	-	550 ns
		$t_{bit(TXD)} = 200\text{ ns}$	[4]	120	-	220 ns
Δt_{rec}	receiver timing symmetry	$t_{bit(TXD)} = 500\text{ ns}$		-65	-	+40 ns
		$t_{bit(TXD)} = 200\text{ ns}$		-45	-	+15 ns
$t_{wake(busdom)}$	bus dominant wake-up time	first pulse (after first recessive) for wake-up on pins CANH and CANL; CAN Offline mode		0.5	-	1.8 μs
		second pulse for wake-up on pins CANH and CANL		0.5	-	1.8 μs
$t_{wake(busrec)}$	bus recessive wake-up time	first pulse for wake-up on pins CANH and CANL; CAN Offline mode		0.5	-	1.8 μs
		second pulse (after first dominant) for wake-up on pins CANH and CANL		0.5	-	1.8 μs
$t_{to(wake)bus}$	bus wake-up time-out time	between first and second dominant pulses; CAN Offline mode		0.8	-	10 ms
$t_{to(dom)TXD}$	TXD dominant time-out time	CAN Active mode; $V_{TXD} = 0\text{ V}$		2.7	-	3.3 ms
$t_{to(silence)}$	bus silence time-out time	recessive time measurement started in all CAN modes		0.95	-	1.17 s

Table 7. Dynamic characteristics ...continued

$T_{vj} = -40\text{ °C to }+150\text{ °C}$; $V_{BAT} = 3\text{ V to }28\text{ V}$; $R_L = R_{(CANH-CANL)} = 60\ \Omega$; all voltages are defined with respect to ground; positive currents flow into the IC; typical values are given at $V_{BAT} = 13\text{ V}$; unless otherwise specified.^[1]

Symbol	Parameter	Conditions	Min	Typ	Max	Unit
$t_{d(\text{busact-bias})}$	delay time from bus active to bias		-	-	200	μs
$t_{\text{startup(CAN)}}$	CAN start-up time	when switching to Active mode (CTS = HIGH)	-	-	220	μs
Pin RSTN: reset pulse width						
$t_{w(\text{rst})}$	reset pulse width	output pulse width				
		cold start	20	-	25	ms
		warm start	1	-	1.5	ms
		input pulse width	18	-	-	μs
Mode transition						
$t_{d(\text{act})\text{norm}}$	normal mode activation delay time	delay before CAN transceiver is activated after the UJA1163A enters Normal mode	-	-	320	μs

- [1] All parameters are guaranteed over the virtual junction temperature range by design. Factory testing uses correlated test conditions to cover the specified temperature and power supply voltage range.
- [2] See [Figure 8](#) and [Figure 11](#).
- [3] See [Figure 9](#) and [Figure 11](#).
- [4] See [Figure 9](#).

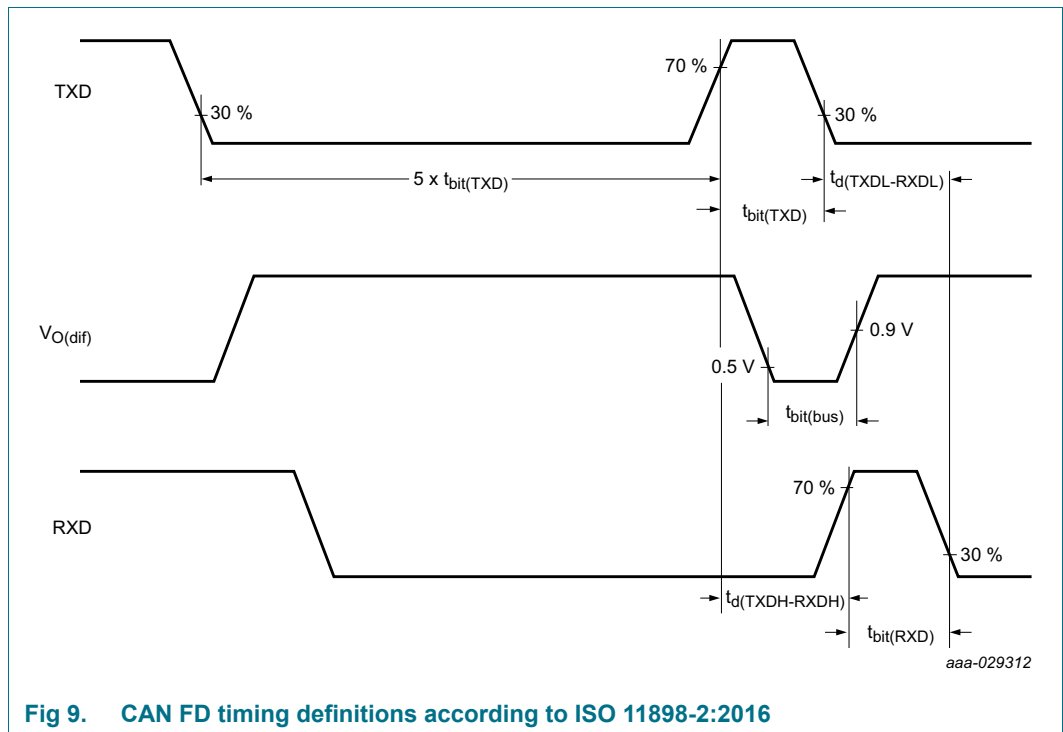
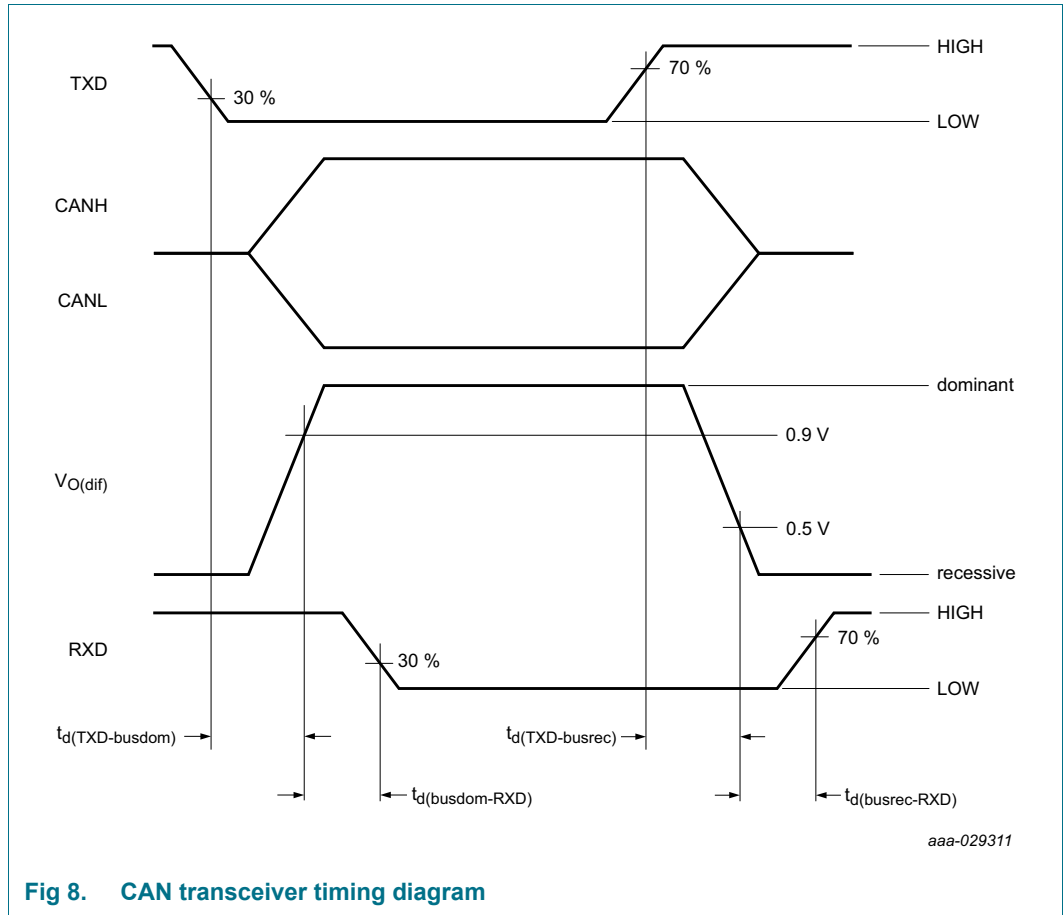

11. Application information

11.1 Application diagram

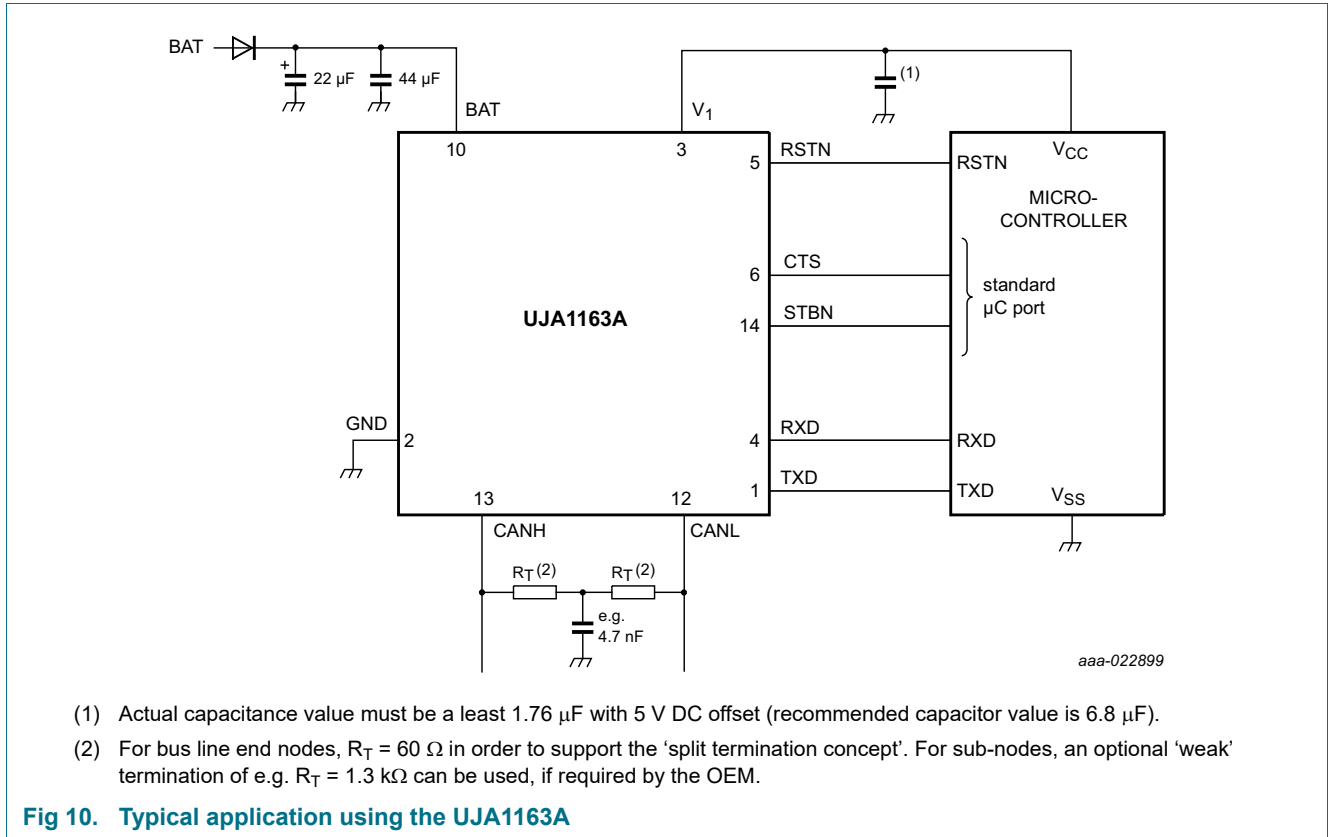

11.2 Application hints

Further information on the application of the UJA1163A can be found in the NXP application hints document *AH1902 Application Hints - Mini high speed CAN system basis chips UJA116xA*.

12. Test information

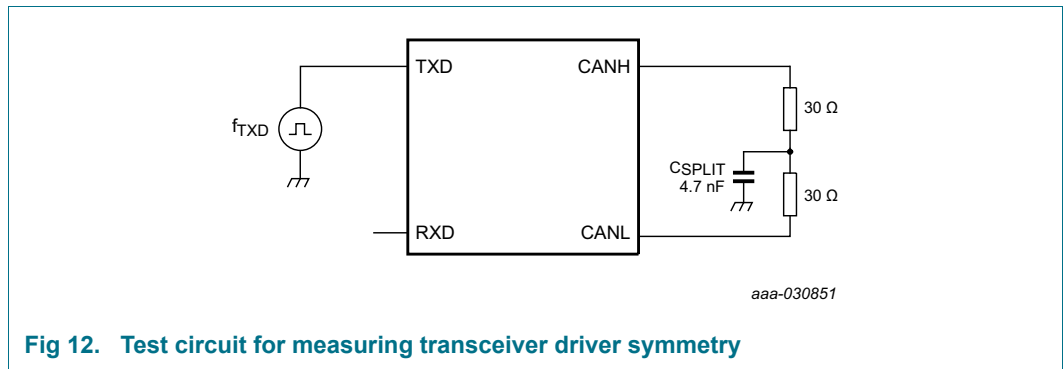
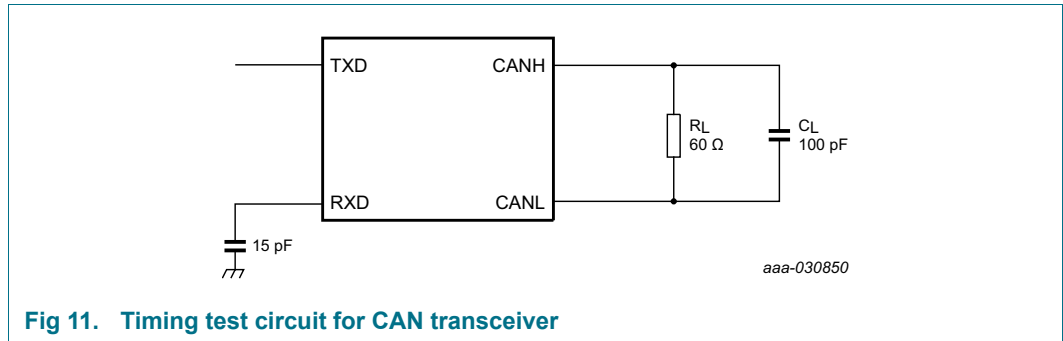

12.1 Quality information

This product has been qualified in accordance with the Automotive Electronics Council (AEC) standard Q100 Rev-G - *Failure mechanism based stress test qualification for integrated circuits*, and is suitable for use in automotive applications.

13. Package outline

HVSON14: plastic, thermal enhanced very thin small outline package; no leads; 14 terminals; body 3 x 4.5 x 0.85 mm

SOT1086-2

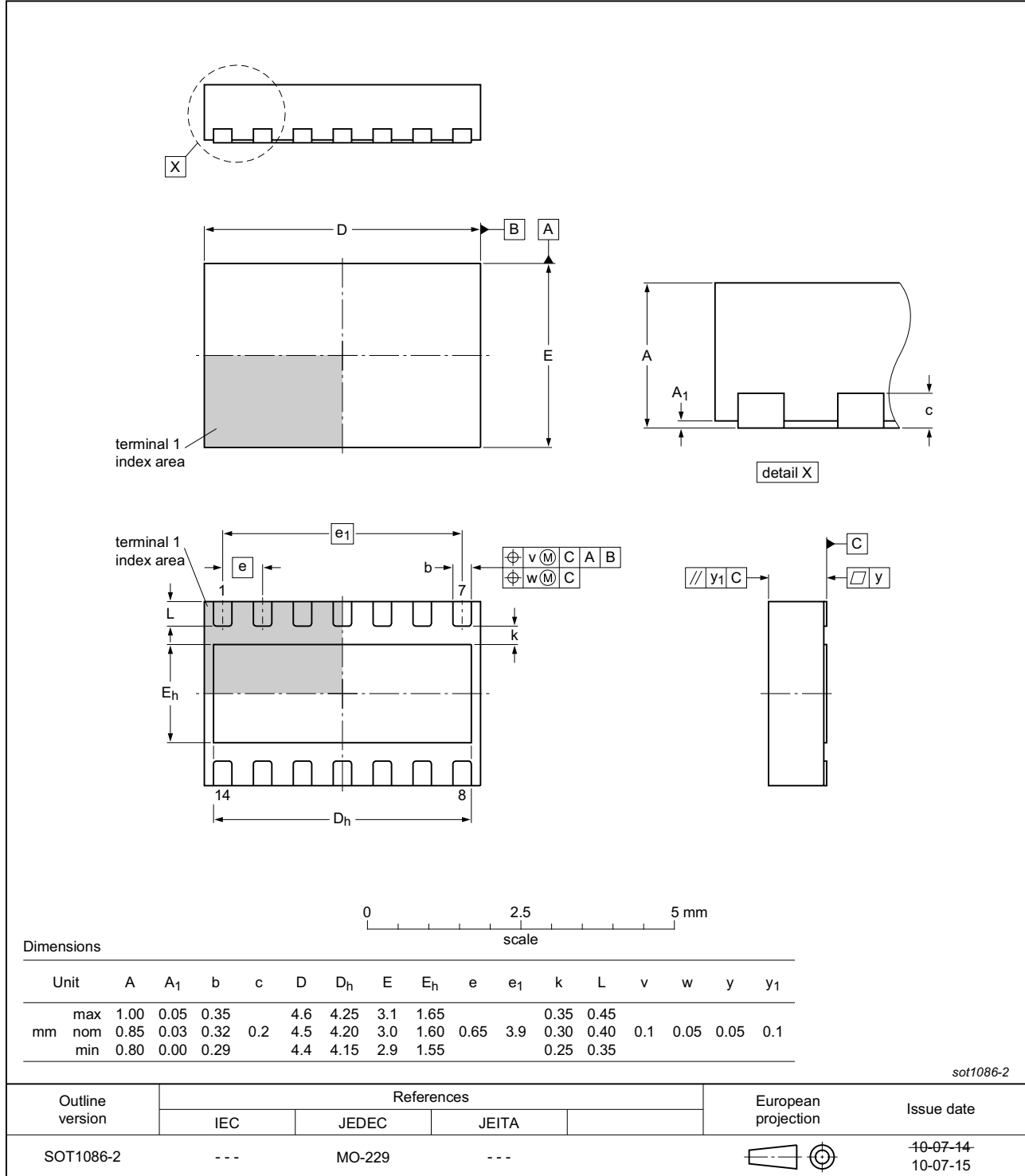

Fig 13. Package outline SOT1086-2 (HVSON14)

14. Handling information

All input and output pins are protected against ElectroStatic Discharge (ESD) under normal handling. When handling ensure that the appropriate precautions are taken as described in *JESD625-A* or equivalent standards.

15. Soldering of SMD packages

This text provides a very brief insight into a complex technology. A more in-depth account of soldering ICs can be found in Application Note *AN10365 "Surface mount reflow soldering description"*.

15.1 Introduction to soldering

Soldering is one of the most common methods through which packages are attached to Printed Circuit Boards (PCBs), to form electrical circuits. The soldered joint provides both the mechanical and the electrical connection. There is no single soldering method that is ideal for all IC packages. Wave soldering is often preferred when through-hole and Surface Mount Devices (SMDs) are mixed on one printed wiring board; however, it is not suitable for fine pitch SMDs. Reflow soldering is ideal for the small pitches and high densities that come with increased miniaturization.

15.2 Wave and reflow soldering

Wave soldering is a joining technology in which the joints are made by solder coming from a standing wave of liquid solder. The wave soldering process is suitable for the following:

- Through-hole components
- Leaded or leadless SMDs, which are glued to the surface of the printed circuit board

Not all SMDs can be wave soldered. Packages with solder balls, and some leadless packages which have solder lands underneath the body, cannot be wave soldered. Also, leaded SMDs with leads having a pitch smaller than ~0.6 mm cannot be wave soldered, due to an increased probability of bridging.

The reflow soldering process involves applying solder paste to a board, followed by component placement and exposure to a temperature profile. Leaded packages, packages with solder balls, and leadless packages are all reflow solderable.

Key characteristics in both wave and reflow soldering are:

- Board specifications, including the board finish, solder masks and vias
- Package footprints, including solder thieves and orientation
- The moisture sensitivity level of the packages
- Package placement
- Inspection and repair
- Lead-free soldering versus SnPb soldering

15.3 Wave soldering

Key characteristics in wave soldering are:

- Process issues, such as application of adhesive and flux, clinching of leads, board transport, the solder wave parameters, and the time during which components are exposed to the wave
- Solder bath specifications, including temperature and impurities

15.4 Reflow soldering

Key characteristics in reflow soldering are:

- Lead-free versus SnPb soldering; note that a lead-free reflow process usually leads to higher minimum peak temperatures (see [Figure 14](#)) than a SnPb process, thus reducing the process window
- Solder paste printing issues including smearing, release, and adjusting the process window for a mix of large and small components on one board
- Reflow temperature profile; this profile includes preheat, reflow (in which the board is heated to the peak temperature) and cooling down. It is imperative that the peak temperature is high enough for the solder to make reliable solder joints (a solder paste characteristic). In addition, the peak temperature must be low enough that the packages and/or boards are not damaged. The peak temperature of the package depends on package thickness and volume and is classified in accordance with [Table 8](#) and [9](#)

Table 8. SnPb eutectic process (from J-STD-020D)

Package thickness (mm)	Package reflow temperature (°C)	
	Volume (mm ³)	
	< 350	≥ 350
< 2.5	235	220
≥ 2.5	220	220

Table 9. Lead-free process (from J-STD-020D)

Package thickness (mm)	Package reflow temperature (°C)		
	Volume (mm ³)		
	< 350	350 to 2000	> 2000
< 1.6	260	260	260
1.6 to 2.5	260	250	245
> 2.5	250	245	245

Moisture sensitivity precautions, as indicated on the packing, must be respected at all times.

Studies have shown that small packages reach higher temperatures during reflow soldering, see [Figure 14](#).

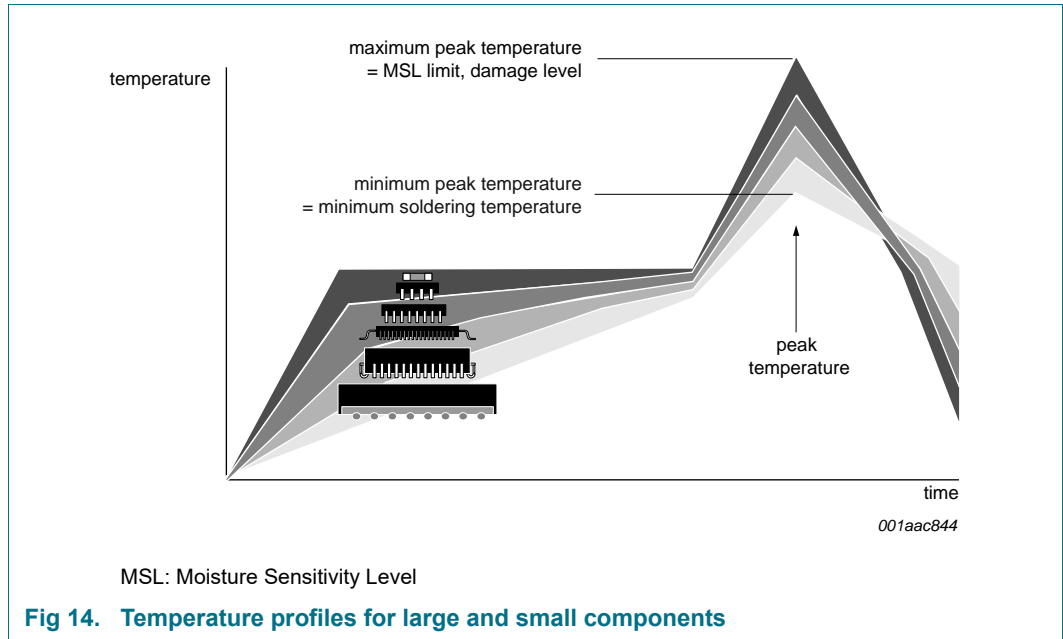

For further information on temperature profiles, refer to Application Note *AN10365* “*Surface mount reflow soldering description*”.

16. Soldering of HVSON packages

[Section 15](#) contains a brief introduction to the techniques most commonly used to solder Surface Mounted Devices (SMD). A more detailed discussion on soldering HVSON leadless package ICs can found in the following application notes:

- *AN10365* “*Surface mount reflow soldering description*”
- *AN10366* “*HVQFN application information*”

17. Appendix: ISO 11898-2:201x parameter cross-reference list

Table 10. ISO 11898-2:201x to NXP data sheet parameter conversion

ISO 11898-2:201x		NXP data sheet	
Parameter	Notation	Symbol	Parameter
HS-PMA dominant output characteristics			
Single ended voltage on CAN_H	V_{CAN_H}	$V_{O(dom)}$	dominant output voltage
Single ended voltage on CAN_L	V_{CAN_L}		
Differential voltage on normal bus load	V_{Diff}	$V_{O(dif)}$	differential output voltage
Differential voltage on effective resistance during arbitration			
Optional: Differential voltage on extended bus load range			
HS-PMA driver symmetry			
Driver symmetry	V_{SYM}	V_{TXsym}	transmitter voltage symmetry
Maximum HS-PMA driver output current			
Absolute current on CAN_H	I_{CAN_H}	$I_{O(sc)dom}$	dominant short-circuit output current
Absolute current on CAN_L	I_{CAN_L}		
HS-PMA recessive output characteristics, bus biasing active/inactive			
Single ended output voltage on CAN_H	V_{CAN_H}	$V_{O(rec)}$	recessive output voltage
Single ended output voltage on CAN_L	V_{CAN_L}		
Differential output voltage	V_{Diff}	$V_{O(dif)}$	differential output voltage
Optional HS-PMA transmit dominant timeout			
Transmit dominant timeout, long	t_{dom}	$t_{to(dom)TXD}$	TXD dominant time-out time
Transmit dominant timeout, short			
HS-PMA static receiver input characteristics, bus biasing active/inactive			
Recessive state differential input voltage range	V_{Diff}	$V_{th(RX)dif}$	differential receiver threshold voltage
Dominant state differential input voltage range		$V_{rec(RX)}$	receiver recessive voltage
		$V_{dom(RX)}$	receiver dominant voltage
HS-PMA receiver input resistance (matching)			
Differential internal resistance	R_{Diff}	$R_{i(dif)}$	differential input resistance
Single ended internal resistance	R_{CAN_H} R_{CAN_L}	R_i	input resistance
Matching of internal resistance	MR	ΔR_i	input resistance deviation
HS-PMA implementation loop delay requirement			
Loop delay	t_{Loop}	$t_{d(TXDH-RXDH)}$	delay time from TXD HIGH to RXD HIGH
		$t_{d(TXDL-RXDL)}$	delay time from TXD LOW to RXD LOW
Optional HS-PMA implementation data signal timing requirements for use with bit rates above 1 Mbit/s up to 2 Mbit/s and above 2 Mbit/s up to 5 Mbit/s			
Transmitted recessive bit width @ 2 Mbit/s / @ 5 Mbit/s, intended	$t_{Bit(Bus)}$	$t_{bit(bus)}$	transmitted recessive bit width
Received recessive bit width @ 2 Mbit/s / @ 5 Mbit/s	$t_{Bit(RXD)}$	$t_{bit(RXD)}$	bit time on pin RXD
Receiver timing symmetry @ 2 Mbit/s / @ 5 Mbit/s	Δt_{Rec}	Δt_{rec}	receiver timing symmetry

Table 10. ISO 11898-2:201x to NXP data sheet parameter conversion

ISO 11898-2:201x		NXP data sheet	
Parameter	Notation	Symbol	Parameter
HS-PMA maximum ratings of V_{CAN_H}, V_{CAN_L} and V_{Diff}			
Maximum rating V _{Diff}	V _{Diff}	V _(CANH-CANL)	voltage between pin CANH and pin CANL
General maximum rating V _{CAN_H} and V _{CAN_L}	V _{CAN_H}	V _x	voltage on pin x
Optional: Extended maximum rating V _{CAN_H} and V _{CAN_L}	V _{CAN_L}		
HS-PMA maximum leakage currents on CAN_H and CAN_L, unpowered			
Leakage current on CAN_H, CAN_L	I _{CAN_H} I _{CAN_L}	I _L	leakage current
HS-PMA bus biasing control timings			
CAN activity filter time, long	t _{Filter}	t _{wake(busdom)} ^[1]	bus dominant wake-up time
CAN activity filter time, short		t _{wake(busrec)} ^[1]	bus recessive wake-up time
Wake-up timeout, short	t _{Wake}	t _{to(wake)bus}	bus wake-up time-out time
Wake-up timeout, long			
Timeout for bus inactivity	t _{Silence}	t _{to(silence)}	bus silence time-out time
Bus Bias reaction time	t _{Bias}	t _{d(busact-bias)}	delay time from bus active to bias

[1] t_{fltr(wake)bus} - bus wake-up filter time, in devices with basic wake-up functionality

18. Revision history

Table 11. Revision history

Document ID	Release date	Data sheet status	Change notice	Supersedes
UJA1163A v.1	20190823	Product data sheet	-	-

19. Legal information

19.1 Data sheet status

Document status ^{[1][2]}	Product status ^[3]	Definition
Objective [short] data sheet	Development	This document contains data from the objective specification for product development.
Preliminary [short] data sheet	Qualification	This document contains data from the preliminary specification.
Product [short] data sheet	Production	This document contains the product specification.

[1] Please consult the most recently issued document before initiating or completing a design.

[2] The term 'short data sheet' is explained in section "Definitions".

[3] The product status of device(s) described in this document may have changed since this document was published and may differ in case of multiple devices. The latest product status information is available on the Internet at URL <http://www.nxp.com>.

19.2 Definitions

Draft — The document is a draft version only. The content is still under internal review and subject to formal approval, which may result in modifications or additions. NXP Semiconductors does not give any representations or warranties as to the accuracy or completeness of information included herein and shall have no liability for the consequences of use of such information.

Short data sheet — A short data sheet is an extract from a full data sheet with the same product type number(s) and title. A short data sheet is intended for quick reference only and should not be relied upon to contain detailed and full information. For detailed and full information see the relevant full data sheet, which is available on request via the local NXP Semiconductors sales office. In case of any inconsistency or conflict with the short data sheet, the full data sheet shall prevail.

Product specification — The information and data provided in a Product data sheet shall define the specification of the product as agreed between NXP Semiconductors and its customer, unless NXP Semiconductors and customer have explicitly agreed otherwise in writing. In no event however, shall an agreement be valid in which the NXP Semiconductors product is deemed to offer functions and qualities beyond those described in the Product data sheet.

19.3 Disclaimers

Limited warranty and liability — Information in this document is believed to be accurate and reliable. However, NXP Semiconductors does not give any representations or warranties, expressed or implied, as to the accuracy or completeness of such information and shall have no liability for the consequences of use of such information. NXP Semiconductors takes no responsibility for the content in this document if provided by an information source outside of NXP Semiconductors.

In no event shall NXP Semiconductors be liable for any indirect, incidental, punitive, special or consequential damages (including - without limitation - lost profits, lost savings, business interruption, costs related to the removal or replacement of any products or rework charges) whether or not such damages are based on tort (including negligence), warranty, breach of contract or any other legal theory.

Notwithstanding any damages that customer might incur for any reason whatsoever, NXP Semiconductors' aggregate and cumulative liability towards customer for the products described herein shall be limited in accordance with the *Terms and conditions of commercial sale* of NXP Semiconductors.

Right to make changes — NXP Semiconductors reserves the right to make changes to information published in this document, including without limitation specifications and product descriptions, at any time and without notice. This document supersedes and replaces all information supplied prior to the publication hereof.

Suitability for use in automotive applications — This NXP Semiconductors product has been qualified for use in automotive applications. Unless otherwise agreed in writing, the product is not designed, authorized or warranted to be suitable for use in life support, life-critical or safety-critical systems or equipment, nor in applications where failure or malfunction of an NXP Semiconductors product can reasonably be expected to result in personal injury, death or severe property or environmental damage. NXP Semiconductors and its suppliers accept no liability for inclusion and/or use of NXP Semiconductors products in such equipment or applications and therefore such inclusion and/or use is at the customer's own risk.

Applications — Applications that are described herein for any of these products are for illustrative purposes only. NXP Semiconductors makes no representation or warranty that such applications will be suitable for the specified use without further testing or modification.

Customers are responsible for the design and operation of their applications and products using NXP Semiconductors products, and NXP Semiconductors accepts no liability for any assistance with applications or customer product design. It is customer's sole responsibility to determine whether the NXP Semiconductors product is suitable and fit for the customer's applications and products planned, as well as for the planned application and use of customer's third party customer(s). Customers should provide appropriate design and operating safeguards to minimize the risks associated with their applications and products.

NXP Semiconductors does not accept any liability related to any default, damage, costs or problem which is based on any weakness or default in the customer's applications or products, or the application or use by customer's third party customer(s). Customer is responsible for doing all necessary testing for the customer's applications and products using NXP Semiconductors products in order to avoid a default of the applications and the products or of the application or use by customer's third party customer(s). NXP does not accept any liability in this respect.

Limiting values — Stress above one or more limiting values (as defined in the Absolute Maximum Ratings System of IEC 60134) will cause permanent damage to the device. Limiting values are stress ratings only and (proper) operation of the device at these or any other conditions above those given in the Recommended operating conditions section (if present) or the Characteristics sections of this document is not warranted. Constant or repeated exposure to limiting values will permanently and irreversibly affect the quality and reliability of the device.

Terms and conditions of commercial sale — NXP Semiconductors products are sold subject to the general terms and conditions of commercial sale, as published at <http://www.nxp.com/profile/terms>, unless otherwise agreed in a valid written individual agreement. In case an individual agreement is concluded only the terms and conditions of the respective agreement shall apply. NXP Semiconductors hereby expressly objects to applying the customer's general terms and conditions with regard to the purchase of NXP Semiconductors products by customer.

No offer to sell or license — Nothing in this document may be interpreted or construed as an offer to sell products that is open for acceptance or the grant, conveyance or implication of any license under any copyrights, patents or other industrial or intellectual property rights.

Export control — This document as well as the item(s) described herein may be subject to export control regulations. Export might require a prior authorization from competent authorities.

Translations — A non-English (translated) version of a document is for reference only. The English version shall prevail in case of any discrepancy between the translated and English versions.

19.4 Trademarks

Notice: All referenced brands, product names, service names and trademarks are the property of their respective owners.

20. Contact information

For more information, please visit: <http://www.nxp.com>

For sales office addresses, please send an email to: salesaddresses@nxp.com

21. Contents

1	General description	1	8	Thermal characteristics	14
2	Features and benefits	1	9	Static characteristics	14
2.1	General	1	10	Dynamic characteristics	18
2.2	Designed for automotive applications	1	11	Application information	21
2.3	Low-drop voltage regulator for 5 V microcontroller supply (V1)	2	11.1	Application diagram	21
2.4	Power Management	2	11.2	Application hints	21
2.5	System control and diagnostic features	2	12	Test information	22
3	Ordering information	2	12.1	Quality information	22
4	Block diagram	3	13	Package outline	23
5	Pinning information	3	14	Handling information	24
5.1	Pinning	3	15	Soldering of SMD packages	24
5.2	Pin description	4	15.1	Introduction to soldering	24
6	Functional description	4	15.2	Wave and reflow soldering	24
6.1	System controller	4	15.3	Wave soldering	24
6.1.1	Operating modes	4	15.4	Reflow soldering	25
6.1.1.1	Normal mode	4	16	Soldering of HVSON packages	26
6.1.1.2	Standby mode	5	17	Appendix: ISO 11898-2:201x parameter cross-reference list	27
6.1.1.3	Reset mode	6	18	Revision history	29
6.1.1.4	Off mode	6	19	Legal information	30
6.1.1.5	Overtemp mode	6	19.1	Data sheet status	30
6.1.1.6	Hardware characterization for the UJA1163A operating modes	7	19.2	Definitions	30
6.1.2	Mode control via pin STBN	7	19.3	Disclaimers	30
6.2	System reset	7	19.4	Trademarks	31
6.2.1	Characteristics of pin RSTN	7	20	Contact information	31
6.2.2	Output reset pulse width	7	21	Contents	32
6.2.3	Reset sources	8			
6.3	Global temperature protection	8			
6.4	Power supplies	8			
6.4.1	Battery supply voltage (V _{BAT})	8			
6.4.2	Low-drop voltage supply for 5 V microcontroller (V1)	8			
6.5	High-speed CAN transceiver	8			
6.5.1	CAN operating modes	9			
6.5.1.1	CAN Active mode	9			
6.5.1.2	CAN Offline and Offline Bias modes	9			
6.5.1.3	CAN Off mode	10			
6.5.2	CAN standard wake-up	10			
6.6	CAN transceiver status pin (CTS)	11			
6.7	CAN fail-safe features	12			
6.7.1	TXD dominant timeout	12			
6.7.2	Pull-up on TXD pin	12			
6.7.3	Pull-down on STBN pin	12			
6.7.4	Loss of power at pin BAT	12			
7	Limiting values	13			

Please be aware that important notices concerning this document and the product(s) described herein, have been included in section 'Legal information'.

© NXP Semiconductors N.V. 2019. All rights reserved.

For more information, please visit: <http://www.nxp.com>
 For sales office addresses, please send an email to: salesaddresses@nxp.com

Date of release: 23 August 2019
 Document identifier: UJA1163A