

UCC27212A-Q1 Automotive 120-V Boot, 4-A Peak, High-Frequency High-Side and Low-Side Driver

1 Features

- Qualified for Automotive Applications
- AECA-Q100 Qualified with the following results:
 - Device temperature grade -40°C to $+140^{\circ}\text{C}$
 - Device HBM classification level 2
 - Device CDM classification level C6
- 5-V Turn-off Under Voltage Lockout (UVLO)
- Drives Two N-Channel MOSFETs in High-Side and Low-Side Configuration With Independent Inputs
- Maximum Boot Voltage 120-V DC
- 4-A Sink, 4-A Source Output Currents
- 0.9- Ω Pullup and Pulldown Resistance
- Input Pins Can Tolerate -10 V to $+20\text{ V}$ and are Independent of Supply Voltage Range
- TTL Compatible Inputs
- 5-V to 17-V VDD Operating Range, (20-V ABS Maximum)
- 7.2-ns Rise and 5.5-ns Fall Time With 1000-pF Load
- Fast Propagation Delay Times (20-ns typical)
- 4-ns Typical Delay Matching
- Available in the SOIC8(Powerpad) package

2 Applications

- Power Supplies in Automotive Applications
- Half-Bridge and Full-Bridge Converters
- High-Voltage Synchronous-Buck Converters
- Two-Switch Forward Converters
- Push-Pull and Active-Clamp Forward Converters
- Class-D Audio Amplifiers

3 Description

The UCC27212A-Q1 device driver is based on the popular UCC27211 MOSFET drivers. In addition, UCC27212A-Q1 offers extended operating range all the way down to 5 V which helps lower power losses.

The peak output pullup and pulldown current is 4-A source and 4-A sink, and pullup and pulldown resistance is 0.9 Ω . This allows for the ability to drive large power MOSFETs with minimized switching losses during the transition through the Miller Plateau of the MOSFET.

The input structure can directly handle -10 V , which increases robustness and also allows direct interface to gate-drive transformers without using rectification diodes. The inputs are also independent of supply voltage and have a 20-V maximum rating.

The switching node of the UCC27212A-Q1 (HS pin) can handle -18-V maximum, which allows the high-side channel to be protected from inherent negative voltages caused by parasitic inductance and stray capacitance. The UCC27212A-Q1 has increased hysteresis that allows for interface to analog or digital PWM controllers with enhanced noise immunity.

The low-side and high-side gate drivers are independently controlled and matched to 4 ns between the turn on and turn off of each other.

An on-chip 100-V rated bootstrap diode eliminates the external discrete diodes. Undervoltage lockout is provided for both the high-side and the low-side drivers which provides symmetric turn on and turn off behavior and forces the outputs low if the drive voltage is below the specified threshold.

Device Information⁽¹⁾

PART NUMBER	PACKAGE	BODY SIZE (NOM)
UCC27212A-Q1	SOIC8(Powerpad)	5.0 mm x 6.0 mm

(1) For all available packages, see the orderable addendum at the end of the data sheet.



Typical Application Diagram

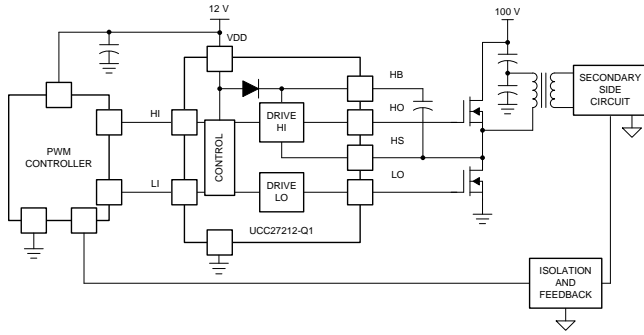

Copyright © 2017, Texas Instruments Incorporated

Propagation Delays vs Supply Voltage T = 25°C

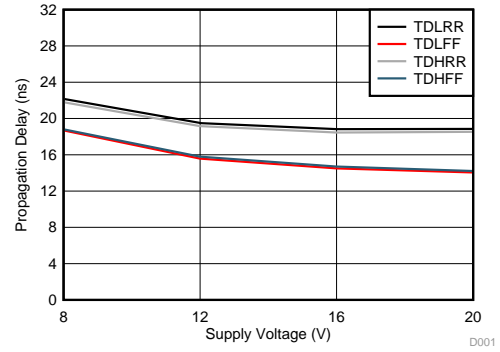

D001

Table of Contents

1	Features	1	7.4	Device Functional Modes.....	16
2	Applications	1	8	Application and Implementation	17
3	Description	1	8.1	Application Information.....	17
4	Revision History	4	8.2	Typical Application	17
5	Pin Configuration and Functions	5	9	Power Supply Recommendations	21
6	Specifications	6	10	Layout	22
6.1	Absolute Maximum Ratings	6	10.1	Layout Guidelines	22
6.2	ESD Ratings	6	10.2	Layout Example	23
6.3	Recommended Operating Conditions.....	7	11	Device and Documentation Support	24
6.4	Thermal Information	7	11.1	Documentation Support	24
6.5	Electrical Characteristics.....	7	11.2	Receiving Notification of Documentation Updates	24
6.6	Switching Characteristics	8	11.3	Community Resources.....	24
6.7	Typical Characteristics	11	11.4	Trademarks	24
7	Detailed Description	14	11.5	Electrostatic Discharge Caution.....	24
7.1	Overview	14	11.6	Glossary	24
7.2	Functional Block Diagram	15	12	Mechanical, Packaging, and Orderable Information	24
7.3	Feature Description.....	15			

4 Revision History

DATE	REVISION	NOTES
July 2017	*	Initial release.

5 Pin Configuration and Functions

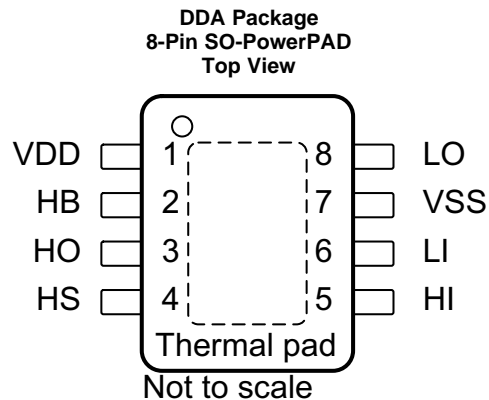

Pin Functions

PIN		TYPE	DESCRIPTION
NO.	NAME		
2	HB	P	High-side bootstrap supply. The bootstrap diode is on-chip but the external bootstrap capacitor is required. Connect positive side of the bootstrap capacitor to this pin. Typical range of HB bypass capacitor is 0.022 μF to 0.1 μF . The capacitor value is dependant on the gate charge of the high-side MOSFET and must also be selected based on speed and ripple criteria.
5	HI	I	High-side input. ⁽¹⁾
3	HO	O	High-side output. Connect to the gate of the high-side power MOSFET.
4	HS	P	High-side source connection. Connect to source of high-side power MOSFET. Connect the negative side of bootstrap capacitor to this pin.
6	LI	I	Low-side input. ⁽¹⁾
8	LO	O	Low-side output. Connect to the gate of the low-side power MOSFET.
1	VDD	P	Positive supply to the lower-gate driver. De-couple this pin to V_{SS} (GND). Typical decoupling capacitor range is 0.22 μF to 4.7 μF (See ⁽²⁾).
7	VSS	—	Negative supply terminal for the device that is generally grounded.
Pad	Thermal pad ⁽³⁾	—	Electrically referenced to V_{SS} (GND). Connect to a large thermal mass trace or GND plane to dramatically improve thermal performance.

(1) HI or LI input is assumed to connect to a low impedance source signal. The source output impedance is assumed less than 100 Ω . If the source impedance is greater than 100 Ω , add a bypassing capacitor, each, between HI and VSS and between LI and VSS. The added capacitor value depends on the noise levels presented on the pins, typically from 1 nF to 10 nF should be effective to eliminate the possible noise effect. When noise is present on two pins, HI or LI, the effect is to cause HO and LO malfunctions to have wrong logic outputs.

(2) For cold temperature applications TI recommends the upper capacitance range. Follow the for PCB layout.

(3) The thermal pad is not directly connected to any leads of the package; however, it is electrically and thermally connected to the substrate which is the ground of the device.

6 Specifications

6.1 Absolute Maximum Ratings

 over operating free-air temperature range (unless otherwise noted)⁽¹⁾

		MIN	MAX	UNIT
$V_{DD}^{(2)}$, $V_{HB} - V_{HS}$	Supply voltage range	-0.3	20	V
V_{LI} , V_{HI}	Input voltages on LI and HI	-10	20	V
V_{LO}	Output voltage on LO	DC	$V_{DD} + 0.3$	V
		Repetitive pulse < 100 ns ⁽³⁾	$V_{DD} + 0.3$	V
V_{HO}	Output voltage on HO	DC	$V_{HS} - 0.3$	V
		Repetitive pulse < 100 ns ⁽³⁾	$V_{HS} - 2$	V
V_{HS}	Voltage on HS	DC	100	V
		Repetitive pulse < 100 ns ⁽³⁾	$-(24\text{ V} - V_{DD})$	V
V_{HB}	Voltage on HB	-0.3	120	V
T_J	Operating virtual junction temperature range	-40	150	°C
Storage temperature, T_{stg}		-65	150	°C

- (1) Stresses beyond those listed under *Absolute Maximum Ratings* may cause permanent damage to the device. These are stress ratings only, which do not imply functional operation of the device at these or any other conditions beyond those indicated under *Recommended Operating Conditions*. Exposure to absolute-maximum-rated conditions for extended periods may affect device reliability.
- (2) All voltages are with respect to V_{SS} unless otherwise noted. Currents are positive into and negative out of the specified terminal.
- (3) Verified at bench characterization. V_{DD} is the value used in an application design.

6.2 ESD Ratings

		VALUE	UNIT
$V_{(ESD)}$	Electrostatic discharge	Human-body model (HBM), per AEC Q100-002	±2000
		Charged-device model (CDM), per AEC Q100-011	±1500

6.3 Recommended Operating Conditions

over operating free-air temperature range, all voltages are with respect to VSS; currents are positive into and negative out of the specified terminal. $-40^{\circ}\text{C} < T_J = T_A < 140^{\circ}\text{C}$ (unless otherwise noted)

		MIN	NOM	MAX	UNIT
V _{DD}	Supply voltage range, V _{HB} – V _{HS}	7	12	17	V
V _{HS}	Voltage on HS	–1		100	V
V _{HS}	Voltage on HS (repetitive pulse < 100 ns)	–(20 V – V _{DD})		110	V
V _{HB}	Voltage on HB	V _{HS} + 8		115	V
	Voltage slew rate on HS			50	V/ns
	Operating junction temperature	–40		140	°C

6.4 Thermal Information

THERMAL METRIC ⁽¹⁾	UCC27212A-Q1		UNIT
	DDA (SOIC8 Powerpad)		
	8 PINS		
R _{θJA}	Junction-to-ambient thermal resistance	37.7	°C/W
R _{θJC(top)}	Junction-to-case (top) thermal resistance	47.2	°C/W
R _{θJB}	Junction-to-board thermal resistance	9.6	°C/W
Ψ _{JT}	Junction-to-top characterization parameter	2.8	°C/W
Ψ _{JB}	Junction-to-board characterization parameter	9.4	°C/W
R _{θJC(bot)}	Junction-to-case (bottom) thermal resistance	3.6	°C/W

(1) For more information about traditional and new thermal metrics, see the [Semiconductor and IC Package Thermal Metrics](#) application report.

6.5 Electrical Characteristics

over operating free-air temperature range, V_{HS} = V_{SS} = 0 V, no load on LO or HO, T_A = T_J = -40°C to $+140^{\circ}\text{C}$, (unless otherwise noted)

PARAMETER	TEST CONDITIONS	MIN	TYP	MAX	UNIT	
SUPPLY CURRENTS, V_{DD} = V_{HB} = 12 V						
I _{DD}	V _{DD} quiescent current	V _(LI) = V _(HI) = 0 V	0.05	0.085	0.17	mA
I _{DDO}	V _{DD} operating current	f = 500 kHz, C _{LOAD} = 0	2.1	2.5	6.5	mA
I _{HB}	Boot voltage quiescent current	V _(LI) = V _(HI) = 0 V	0.015	0.065	0.1	mA
I _{HBO}	Boot voltage operating current	f = 500 kHz, C _{LOAD} = 0	1.5	2.5	5.1	mA
I _{HBS}	HB to V _{SS} quiescent current	V _(HS) = V _(HB) = 115 V		0.0005	1	μA
I _{HBSO}	HB to V _{SS} operating current	f = 500 kHz, C _{LOAD} = 0		0.07	1.2	mA
SUPPLY CURRENTS, V_{DD} = V_{HB} = 6.8 V						
I _{DD}	V _{DD} quiescent current	V _(LI) = V _(HI) = 0 V	0.02	0.065	0.14	mA
I _{DDO}	V _{DD} operating current	f = 500 kHz, C _{LOAD} = 0	0.7	1.4	6.5	mA
I _{HB}	Boot voltage quiescent current	V _(LI) = V _(HI) = 0 V	0.01	0.04	0.08	mA
I _{HBO}	Boot voltage operating current	f = 500 kHz, C _{LOAD} = 0	0.5	1.23	5.1	mA
I _{HBS}	HB to V _{SS} quiescent current	V _(HS) = V _(HB) = 115 V		0.0005	1	μA
I _{HBSO}	HB to V _{SS} operating current	f = 500 kHz, C _{LOAD} = 0		0.07	1.2	mA
INPUT, V_{DD} = V_{HB} = 12 V						
V _{HIT}	Input voltage threshold		1.7	2.3	2.55	V
V _{LIT}	Input voltage threshold		1.2	1.6	1.9	V
V _{IHYS}	Input voltage hysteresis			700		mV
R _{IN}	Input pulldown resistance			68		kΩ
INPUT, V_{DD} = V_{HB} = 6.8 V						
V _{HIT}	Input voltage threshold		1.6	2.0	2.6	V

Electrical Characteristics (continued)

over operating free-air temperature range, $V_{HS} = V_{SS} = 0$ V, no load on LO or HO, $T_A = T_J = -40^\circ\text{C}$ to $+140^\circ\text{C}$, (unless otherwise noted)

PARAMETER	TEST CONDITIONS	MIN	TYP	MAX	UNIT	
V_{LIT}	Input voltage threshold	1.1	1.5	2.1	V	
V_{IHYS}	Input voltage hysteresis		500		mV	
R_{IN}	Input pulldown resistance		68		k Ω	
UNDER-VOLTAGE LOCKOUT (UVLO), $V_{DD} = V_{HB} = 12$ V						
V_{DDR}	V_{DD} turnon threshold	4.9	5.7	6.4	V	
V_{DDHYS}	Hysteresis		0.4		V	
V_{HBR}	V_{HB} turnon threshold	4.35	5.3	6.3	V	
V_{HBHYS}	Hysteresis		0.3		V	
BOOTSTRAP DIODE, $V_{DD} = V_{HB} = 12$ V						
V_F	Low-current forward voltage	$I_{VDD-HB} = 100 \mu\text{A}$	0.65	0.8	V	
V_{FI}	High-current forward voltage	$I_{VDD-HB} = 100 \text{mA}$	0.85	0.95	V	
R_D	Dynamic resistance, $\Delta V/\Delta I$	$I_{VDD-HB} = 100 \text{mA}$ and 80mA	0.3	0.5	Ω	
BOOTSTRAP DIODE, $V_{DD} = V_{HB} = 6.8$ V						
V_F	Low-current forward voltage	$I_{VDD-HB} = 100 \mu\text{A}$	0.65	0.8	V	
V_{FI}	High-current forward voltage	$I_{VDD-HB} = 100 \text{mA}$	0.85	0.95	V	
R_D	Dynamic resistance, $\Delta V/\Delta I$	$I_{VDD-HB} = 100 \text{mA}$ and 80mA	0.3	0.5	Ω	
LO GATE DRIVER, $V_{DD} = V_{HB} = 12$ V						
V_{LOL}	Low-level output voltage		0.05	0.1	0.19	V
V_{LOH}	High level output voltage		0.1	0.16	0.29	V
	Peak pullup current ⁽¹⁾		3.7		A	
	Peak pulldown current ⁽¹⁾		4.5		A	
LO GATE DRIVER, $V_{DD} = V_{HB} = 6.8$ V						
V_{LOL}	Low-level output voltage	$I_{LO} = 100 \text{mA}$	0.04	0.13	0.35	V
V_{LOH}	High level output voltage	$I_{LO} = -100 \text{mA}$, $V_{LOH} = V_{DD} - V_{LO}$	0.12	0.23	0.42	V
	Peak pullup current	$V_{LO} = 0$ V	1.3		A	
	Peak pulldown current	$V_{LO} = 12$ V for $V_{DD} = 6.8$ V	1.7		A	
HO GATE DRIVER, $V_{DD} = V_{HB} = 12$ V						
V_{HOL}	Low-level output voltage		0.05	0.1	0.19	V
V_{HOH}	High-level output voltage		0.1	0.16	0.29	V
	Peak pullup current ⁽¹⁾		3.7		A	
	Peak pulldown current ⁽¹⁾		4.5		A	
HO GATE DRIVER, $V_{DD} = V_{HB} = 6.8$ V						
V_{LOL}	Low-level output voltage	$I_{HO} = 100 \text{mA}$	0.04	0.13	0.35	V
V_{LOH}	High level output voltage	$I_{HO} = -100 \text{mA}$, $V_{HOH} = V_{HB} - V_{HO}$	0.12	0.23	0.42	V
	Peak pullup current	$V_{HO} = 0$ V	1.3		A	
	Peak pulldown current	$V_{HO} = 12$ V for $V_{DD} = 6.8$ V	1.7		A	

(1) Ensured by design.

6.6 Switching Characteristics

over operating free-air temperature range (unless otherwise noted)

PARAMETER	TEST CONDITIONS	MIN	TYP	MAX	UNIT	
PROPAGATION DELAYS, $V_{DD} = V_{HB} = 12$ V						
T_{DLFF}	V_{LI} falling to V_{LO} falling	$C_{LOAD} = 0$	10	16	30	ns
T_{DHFF}	V_{HI} falling to V_{HO} falling	$C_{LOAD} = 0$	10	16	30	ns
T_{DLRR}	V_{LI} rising to V_{LO} rising	$C_{LOAD} = 0$	10	20	42	ns

Switching Characteristics (continued)

over operating free-air temperature range (unless otherwise noted)

PARAMETER		TEST CONDITIONS	MIN	TYP	MAX	UNIT
T_{DHRR}	V_{HI} rising to V_{HO} rising	$C_{LOAD} = 0$	10	20	42	ns
PROPAGATION DELAYS, $V_{DD} = V_{HB} = 6.8$ V						
T_{DLFF}	V_{LI} falling to V_{LO} falling	$C_{LOAD} = 0$	10	24	50	ns
T_{DHFF}	V_{HI} falling to V_{HO} falling	$C_{LOAD} = 0$	10	24	50	ns
T_{DLRR}	V_{LI} rising to V_{LO} rising	$C_{LOAD} = 0$	13	28	57	ns
T_{DHRR}	V_{HI} rising to V_{HO} rising	$C_{LOAD} = 0$	13	28	57	ns
DELAY MATCHING, $V_{DD} = V_{HB} = 12$ V						
T_{MON}	From HO OFF to LO ON	$T_J = 25^\circ\text{C}$		4	9.5	ns
		$T_J = -40^\circ\text{C}$ to $+140^\circ\text{C}$		4	17	ns
T_{MOFF}	From LO OFF to HO ON	$T_J = 25^\circ\text{C}$		4	9.5	ns
		$T_J = -40^\circ\text{C}$ to $+140^\circ\text{C}$		4	17	ns
DELAY MATCHING, $V_{DD} = V_{HB} = 6.8$ V						
T_{MON}	From HO OFF to LO ON	$T_J = 25^\circ\text{C}$		8		ns
		$T_J = -40^\circ\text{C}$ to $+140^\circ\text{C}$		8	18	ns
T_{MOFF}	From LO OFF to HO ON	$T_J = 25^\circ\text{C}$		6		ns
		$T_J = -40^\circ\text{C}$ to $+140^\circ\text{C}$		6	18	ns
OUTPUT RISE AND FALL TIME, $V_{DD} = V_{HB} = 12$ V						
t_R	LO rise time	$C_{LOAD} = 1000$ pF, from 10% to 90%		7.8		ns
t_R	HO rise time	$C_{LOAD} = 1000$ pF, from 10% to 90%		7.8		ns
t_F	LO fall time	$C_{LOAD} = 1000$ pF, from 90% to 10%		6.0		ns
t_F	HO fall time	$C_{LOAD} = 1000$ pF, from 90% to 10%		6.0		ns
t_R	LO, HO	$C_{LOAD} = 0.1$ μF , (3 V to 9 V)		0.36	0.6	μs
t_F	LO, HO	$C_{LOAD} = 0.1$ μF , (9 V to 3 V)		0.20	0.4	μs
OUTPUT RISE AND FALL TIME, $V_{DD} = V_{HB} = 6.8$ V						
t_R	LO rise time	$C_{LOAD} = 1000$ pF, from 10% to 90%		9.5		ns
t_R	HO rise time	$C_{LOAD} = 1000$ pF, from 10% to 90%		13.0		ns
t_F	LO fall time	$C_{LOAD} = 1000$ pF, from 90% to 10%		9.5		ns
t_F	HO fall time	$C_{LOAD} = 1000$ pF, from 90% to 10%		13.0		ns
t_R	LO, HO	$C_{LOAD} = 0.1$ μF , (30% to 70%)		0.45	0.7	μs
t_F	LO, HO	$C_{LOAD} = 0.1$ μF , (70% to 30%)		0.2	0.5	μs
MISCELLANEOUS						
Minimum input pulse width that changes the output					100	ns
Bootstrap diode turnoff time ⁽¹⁾⁽²⁾		$I_F = 20$ mA, $I_{REV} = 0.5$ A ⁽³⁾		20		ns
Extended output pulse		when $V_{DD} = V_{HB} = 6.8$ V, $V_{HS} = 100$ V, and input pulse width is 100 ns		250		ns

(1) Ensured by design.

 (2) I_F : Forward current applied to bootstrap diode, I_{REV} : Reverse current applied to bootstrap diode.

 (3) Typical values for $T_A = 25^\circ\text{C}$.

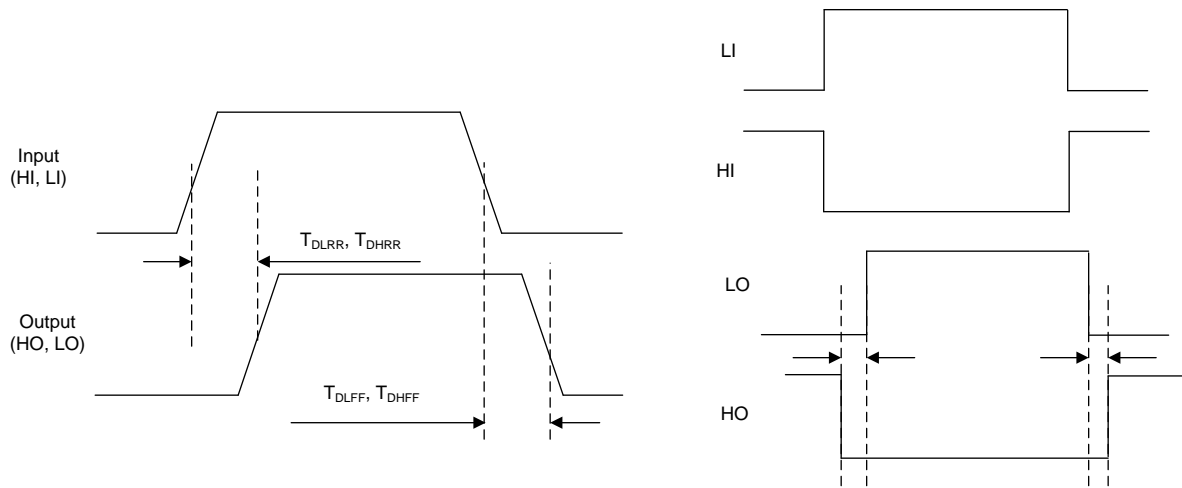

Figure 1. Timing Diagram

6.7 Typical Characteristics

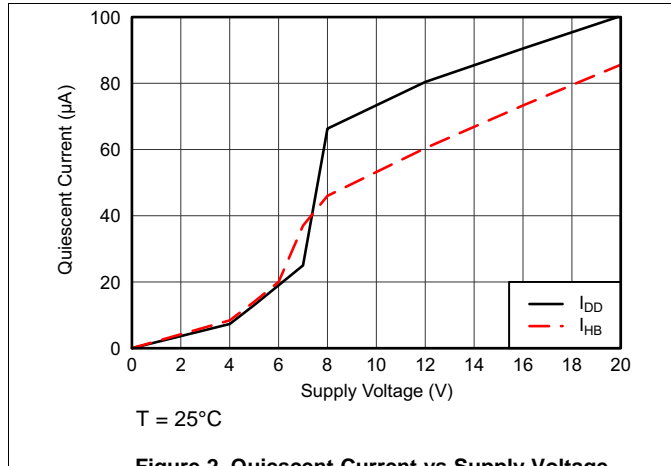

Figure 2. Quiescent Current vs Supply Voltage

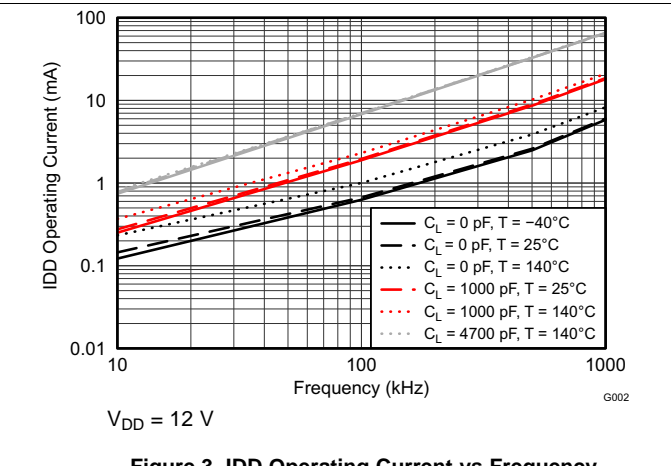

Figure 3. IDD Operating Current vs Frequency

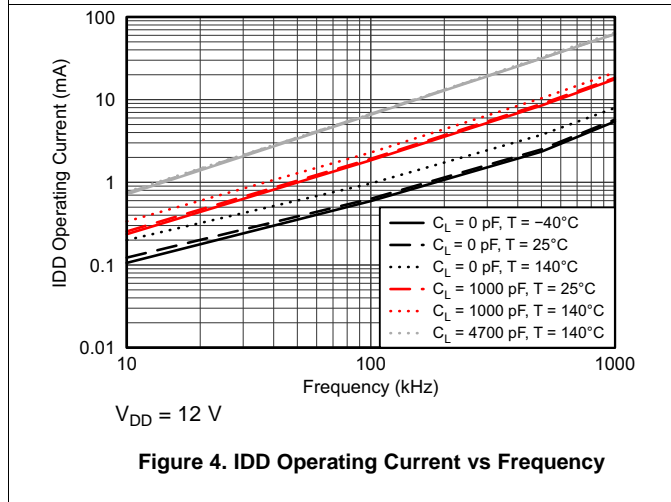

Figure 4. IDD Operating Current vs Frequency

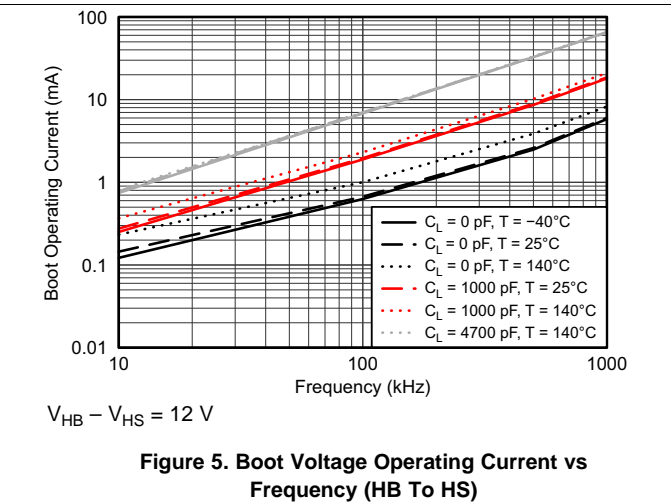

Figure 5. Boot Voltage Operating Current vs Frequency (HB To HS)

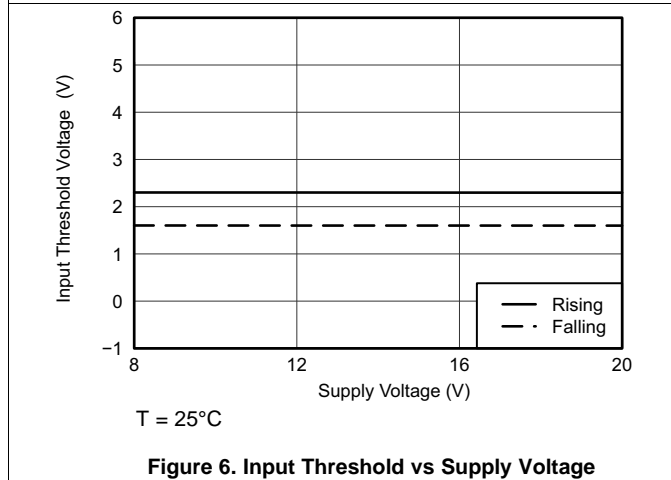

Figure 6. Input Threshold vs Supply Voltage

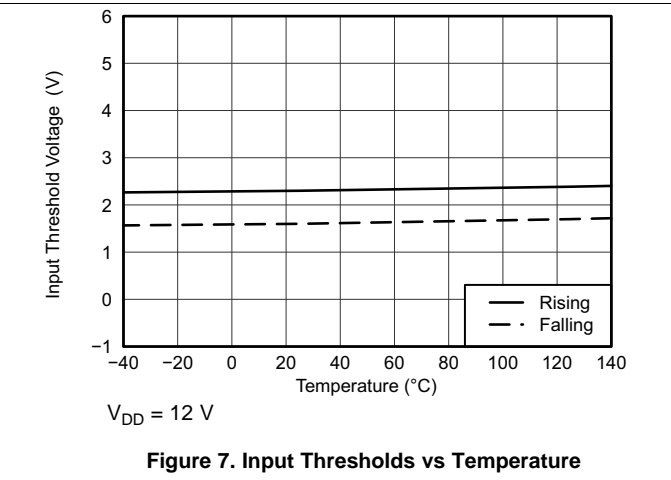
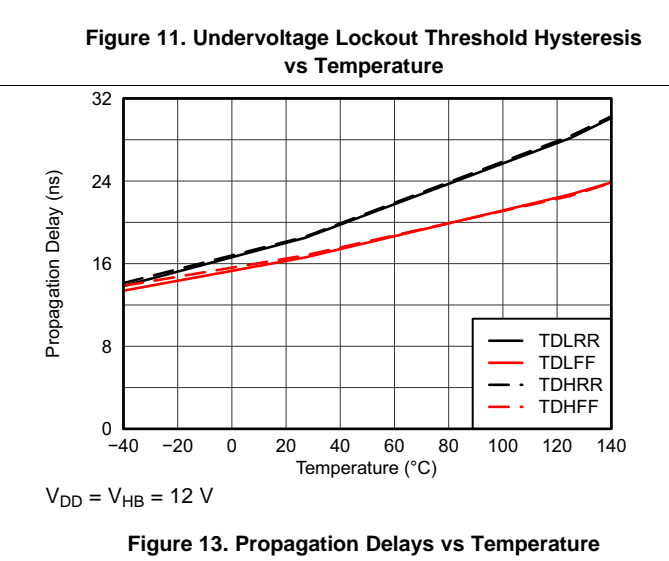
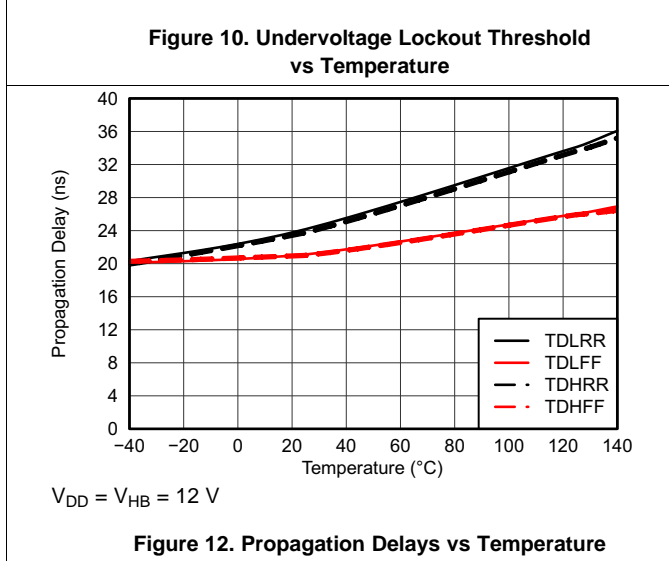
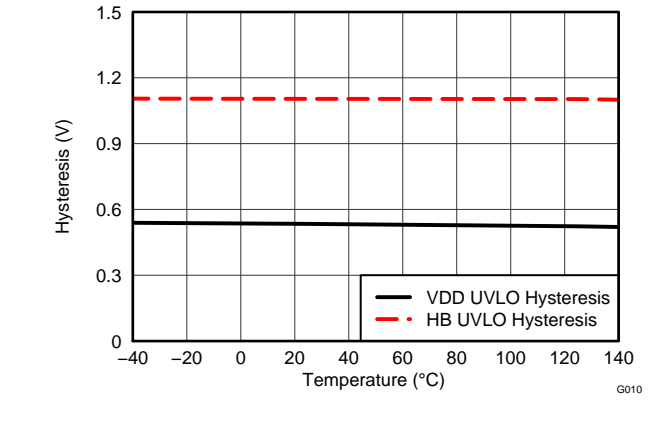
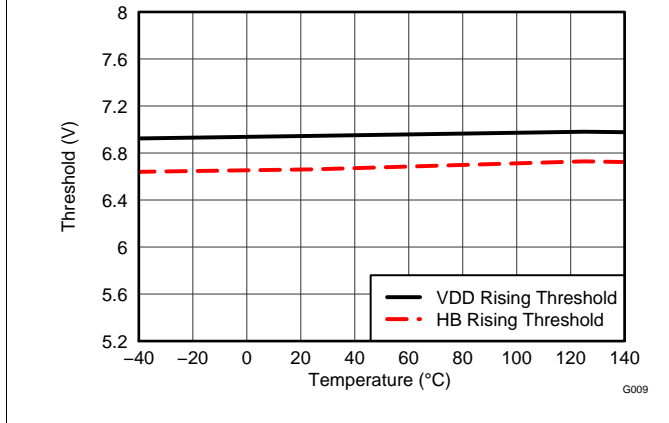
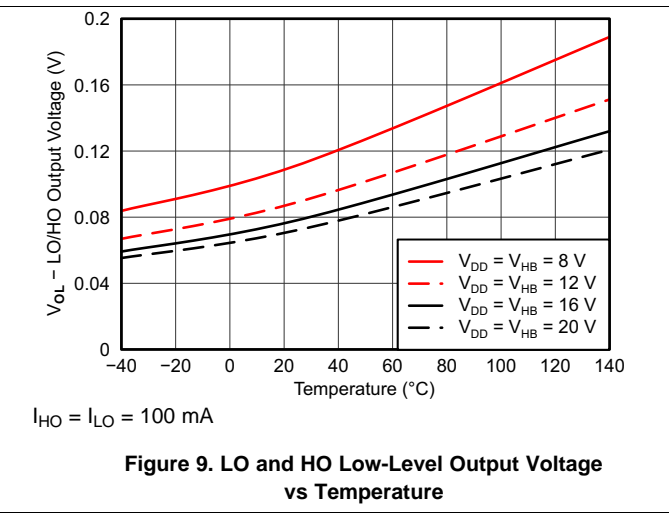
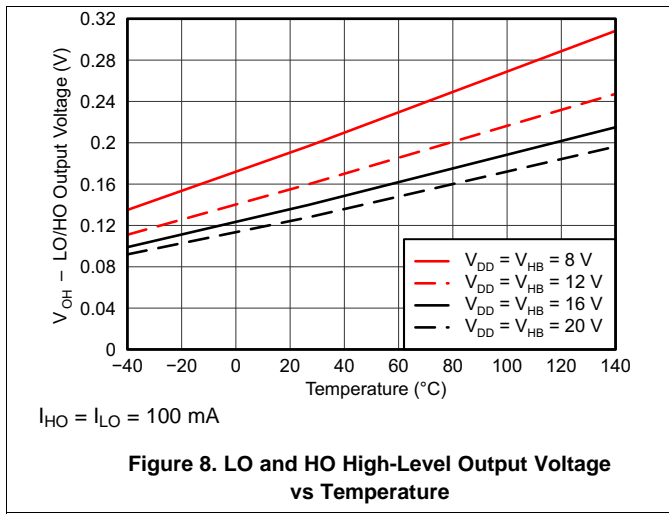
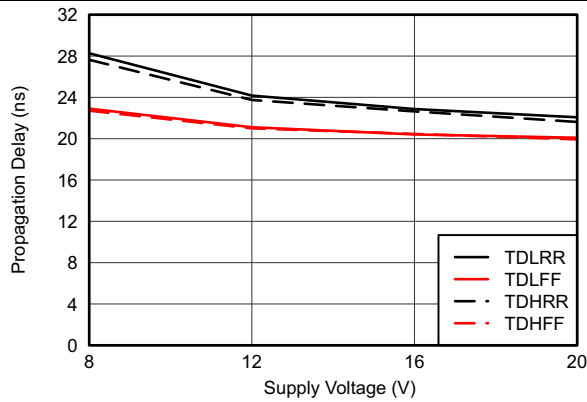

Figure 7. Input Thresholds vs Temperature

Typical Characteristics (continued)



Typical Characteristics (continued)



T = 25°C

Figure 14. Propagation Delays vs Supply Voltage (V_{DD} = V_{HB})

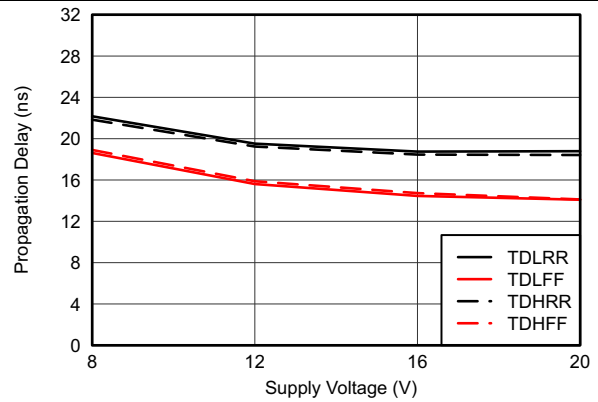

T = 25°C

Figure 15. Propagation Delays vs Supply Voltage (V_{DD} = V_{HB})

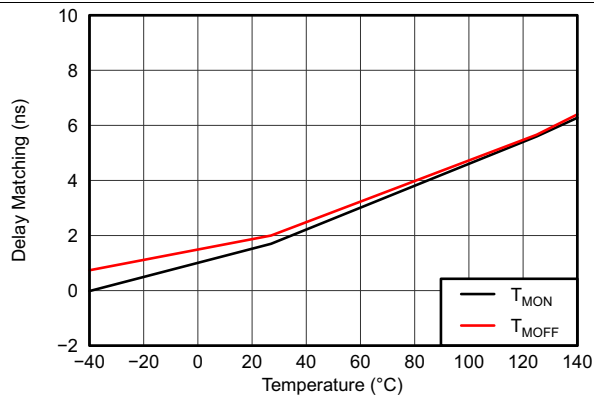

V_{DD} = V_{HB} = 12 V

Figure 16. Delay Matching vs Temperature

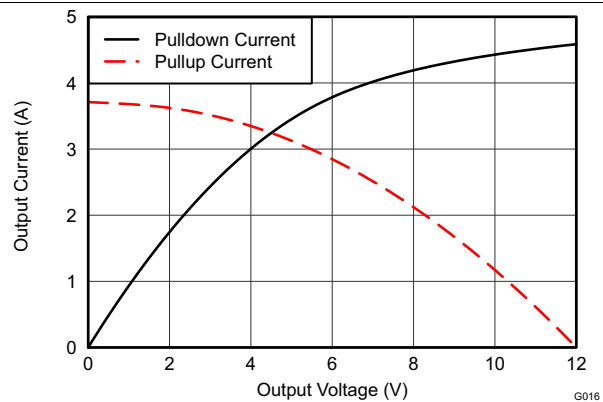

V_{DD} = V_{HB} = 12 V

Figure 17. Output Current vs Output Voltage

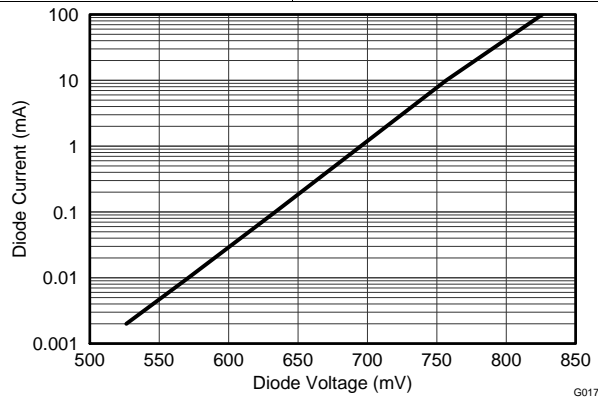

Figure 18. Diode Current vs Diode Voltage

7 Detailed Description

7.1 Overview

The UCC27212A-Q1 device represents Texas Instruments' latest generation of high-voltage gate drivers, which are designed to drive both the high-side and low-side of N-Channel MOSFETs in a half- and full-bridge or synchronous-buck configuration. The floating high-side driver can operate with supply voltages of up to 120 V, which allows for N-Channel MOSFET control in half-bridge, full-bridge, push-pull, two-switch forward, and active clamp forward converters.

The UCC27212A-Q1 device feature 4-A source and sink capability, industry best-in-class switching characteristics and a host of other features listed in [Table 1](#). These features combine to ensure efficient, robust and reliable operation in high-frequency switching power circuits.

Table 1. UCC27212A-Q1 Highlights

FEATURE	BENEFIT
4-A source and sink current with 0.9-Ω output resistance	High peak current ideal for driving large power MOSFETs with minimal power loss (fast-drive capability at Miller plateau)
Input pins (HI and LI) can directly handle –10 VDC up to 20 VDC	Increased robustness and ability to handle undershoot and overshoot can interface directly to gate-drive transformers without having to use rectification diodes.
120-V internal boot diode	Provides voltage margin to meet telecom 100-V surge requirements
Switch node (HS pin) able to handle –18 V maximum for 100 ns	Allows the high-side channel to have extra protection from inherent negative voltages caused by parasitic inductance and stray capacitance
Robust ESD circuitry to handle voltage spikes	Excellent immunity to large dV/dT conditions
18-ns propagation delay with 7.2-ns rise time and 5.5-ns fall time	Best-in-class switching characteristics and extremely low-pulse transmission distortion
2-ns (typical) delay matching between channels	Avoids transformer volt-second offset in bridge
Symmetrical UVLO circuit	Ensures high-side and low-side shut down at the same time
TTL optimized thresholds with increased hysteresis	Complementary to analog or digital PWM controllers; increased hysteresis offers added noise immunity

In the UCC27212A-Q1 device, the high side and low side each have independent inputs that allow maximum flexibility of input control signals in the application. The boot diode for the high-side driver bias supply is internal to the UCC27212A-Q1. The UCC27212A-Q1 is the TTL or logic compatible version. The high-side driver is referenced to the switch node (HS), which is typically the source pin of the high-side MOSFET and drain pin of the low-side MOSFET. The low-side driver is referenced to V_{SS} , which is typically ground. The UCC27212A-Q1 functions are divided into the input stages, UVLO protection, level shift, boot diode, and output driver stages.

7.2 Functional Block Diagram

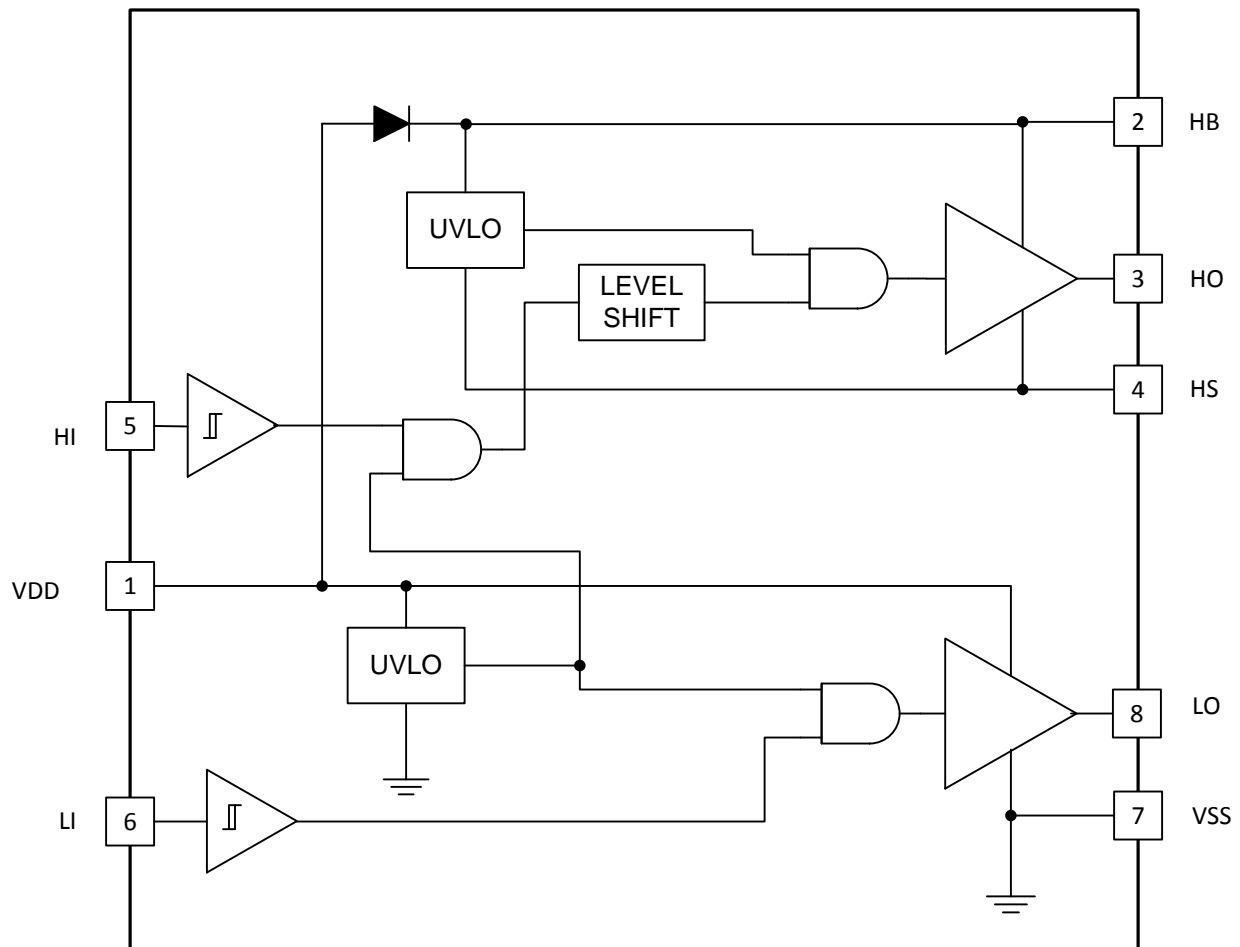

Copyright © 2017, Texas Instruments Incorporated

7.3 Feature Description

7.3.1 Input Stages

The input stages provide the interface to the PWM output signals. The input stages of the UCC27212A-Q1 device have impedance of 70-k Ω nominal and input capacitance is approximately 2 pF. Pulldown resistance to V_{SS} (ground) is 70 k Ω . The logic level compatible input provides a rising threshold of 2.3 V and a falling threshold of 1.6 V. There is enough input hysteresis to avoid noise related jitter issues on the input.

7.3.2 Undervoltage Lockout (UVLO)

The bias supplies for the high-side and low-side drivers have UVLO protection. V_{DD} as well as V_{HB} to V_{HS} differential voltages are monitored. The V_{DD} UVLO disables both drivers when V_{DD} is below the specified threshold. The rising V_{DD} threshold is 5.7 V with 0.4-V hysteresis. The V_{HB} UVLO disables only the high-side driver when the V_{HB} to V_{HS} differential voltage is below the specified threshold. The V_{HB} UVLO rising threshold is 5.3 V with 0.4 V hysteresis.

Feature Description (continued)

7.3.3 Level Shift

The level shift circuit is the interface from the high-side input to the high-side driver stage which is referenced to the switch node (HS). The level shift allows control of the HO output referenced to the HS pin and provides excellent delay matching with the low-side driver.

7.3.4 Boot Diode

The boot diode necessary to generate the high-side bias is included in the UCC27212A-Q1 family of drivers. The diode anode is connected to V_{DD} and cathode connected to V_{HB} . With the V_{HB} capacitor connected to HB and the HS pins, the V_{HB} capacitor charge is refreshed every switching cycle when HS transitions to ground. The boot diode provides fast recovery times, low diode resistance, and voltage rating margin to allow for efficient and reliable operation.

7.3.5 Output Stages

The output stages are the interface to the power MOSFETs in the power train. High slew rate, low resistance and high peak current capability of both output drivers allow for efficient switching of the power MOSFETs. The low-side output stage is referenced from V_{DD} to V_{SS} and the high side is referenced from V_{HB} to V_{HS} .

7.4 Device Functional Modes

The device operates in normal mode and UVLO mode. See the [Undervoltage Lockout \(UVLO\)](#) section for information on UVLO operation mode. In the normal mode the output state is dependent on states of the HI and LI pins. [Table 2](#) lists the output states for different input pin combinations.

Table 2. Device Logic Table

HI PIN	LI PIN	HO ⁽¹⁾	LO ⁽²⁾
L	L	L	L
L	H	L	H
H	L	H	L
H	H	H	H

(1) HO is measured with respect to HS.

(2) LO is measured with respect to VSS.

8 Application and Implementation

NOTE

Information in the following applications sections is not part of the TI component specification, and TI does not warrant its accuracy or completeness. TI's customers are responsible for determining suitability of components for their purposes. Customers should validate and test their design implementation to confirm system functionality.

8.1 Application Information

To affect fast switching of power devices and reduce associated switching power losses, a powerful gate driver is employed between the PWM output of controllers and the gates of the power semiconductor devices. Also, gate drivers are indispensable when it is impossible for the PWM controller to directly drive the gates of the switching devices. With the advent of digital power, this situation will be often encountered because the PWM signal from the digital controller is often a 3.3-V logic signal which cannot effectively turn on a power switch. Level shifting circuitry is needed to boost the 3.3-V signal to the gate-drive voltage (such as 12 V) in order to fully turn on the power device and minimize conduction losses. Traditional buffer drive circuits based on NPN/PNP bipolar transistors in totem-pole arrangement, being emitter follower configurations, prove inadequate with digital power because they lack level-shifting capability. Gate drivers effectively combine both the level-shifting and buffer-drive functions. Gate drivers also find other needs such as minimizing the effect of high-frequency switching noise by locating the high-current driver physically close to the power switch, driving gate-drive transformers, and controlling floating power-device gates, reducing power dissipation and thermal stress in controllers by moving gate charge power losses from the controller into the driver.

Finally, emerging wide band-gap power device technologies such as GaN based switches, which are capable of supporting very high switching frequency operation, are driving very special requirements in terms of gate drive capability. These requirements include operation at low VDD voltages (5 V or lower), low propagation delays and availability in compact, low-inductance packages with good thermal capability. Gate-driver devices are extremely important components in switching power, and they combine the benefits of high-performance, low-cost component count and board-space reduction as well as simplified system design.

8.2 Typical Application

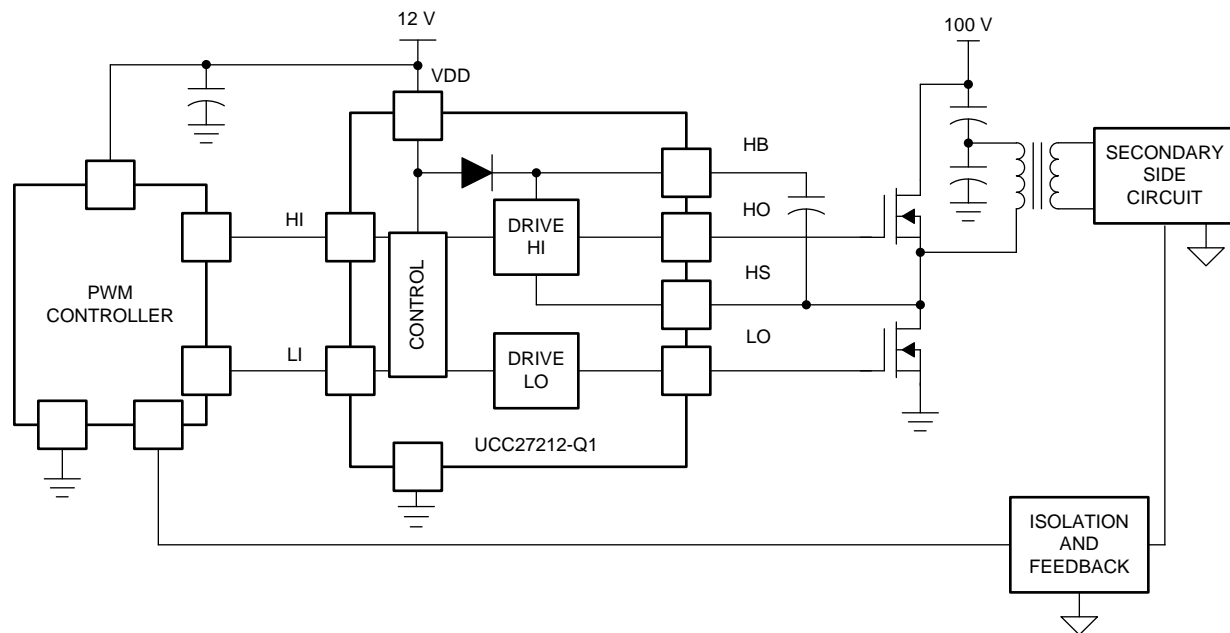

Copyright © 2017, Texas Instruments Incorporated

Figure 19. UCC27212A-Q1 Typical Application

Typical Application (continued)

8.2.1 Design Requirements

For this design example, use the parameters listed in [Table 3](#).

Table 3. Design Specifications

DESIGN PARAMETER	EXAMPLE VALUE
Supply voltage, VDD	12 V
Voltage on HS, VHS	0 V to 100 V
Voltage on HB, VHB	12 V to 112 V
Output current rating, IO	–4 A to 4 A
Operating frequency	500 kHz

8.2.2 Detailed Design Procedure

8.2.2.1 Power Dissipation

Power dissipation of the gate driver has two portions as shown in [Equation 1](#).

$$P_{DISS} = P_{DC} + P_{SW} \quad (1)$$

Use [Equation 2](#) to calculate the DC portion of the power dissipation (PDC).

$$PDC = I_Q \times V_{DD}$$

where

- I_Q is the quiescent current for the driver. (2)

The quiescent current is the current consumed by the device to bias all internal circuits such as input stage, reference voltage, logic circuits, protections, and also any current associated with switching of internal devices when the driver output changes state (such as charging and discharging of parasitic capacitances, parasitic shoot-through, and so forth). The UCC27212A-Q1 features very low quiescent currents (less than 0.17 mA, refer to the table and contain internal logic to eliminate any shoot-through in the output driver stage. Thus the effect of the PDC on the total power dissipation within the gate driver can be safely assumed to be negligible. The power dissipated in the gate-driver package during switching (PSW) depends on the following factors:

- Gate charge required of the power device (usually a function of the drive voltage VG, which is very close to input bias supply voltage VDD)
- Switching frequency
- Use of external gate resistors. When a driver device is tested with a discrete, capacitive load calculating the power that is required from the bias supply is fairly simple. The energy that must be transferred from the bias supply to charge the capacitor is given by [Equation 3](#).

$$EG = \frac{1}{2} C_{LOAD} \times V_{DD}^2$$

where

- C_{LOAD} is load capacitor
- V_{DD} is bias voltage feeding the driver (3)

There is an equal amount of energy dissipated when the capacitor is charged and when it is discharged. This leads to a total power loss given by [Equation 4](#).

$$PG = C_{LOAD} \times V_{DD}^2 \times f_{SW}$$

where

- f_{SW} is the switching frequency (4)

The switching load presented by a power MOSFET/IGBT is converted to an equivalent capacitance by examining the gate charge required to switch the device. This gate charge includes the effects of the input capacitance plus the added charge needed to swing the drain voltage of the power device as it switches between the ON and OFF states. Most manufacturers provide specifications of typical and maximum gate charge, in nC, to switch the device under specified conditions. Using the gate charge Qg, determine the power that must be dissipated when switching a capacitor which is calculated using the equation $Q_G = C_{LOAD} \times V_{DD}$ to provide [Equation 5](#) for power.

$$P_G = C_{LOAD} \times V_{DD}^2 \times f_{SW} = Q_G \times V_{DD} \times f_{SW} \quad (5)$$

This power P_G is dissipated in the resistive elements of the circuit when the MOSFET/IGBT is being turned on and off. Half of the total power is dissipated when the load capacitor is charged during turnon, and the other half is dissipated when the load capacitor is discharged during turnoff. When no external gate resistor is employed between the driver and MOSFET/IGBT, this power is completely dissipated inside the driver package. With the use of external gate-drive resistors, the power dissipation is shared between the internal resistance of driver and external gate resistor.

8.2.3 Application Curves

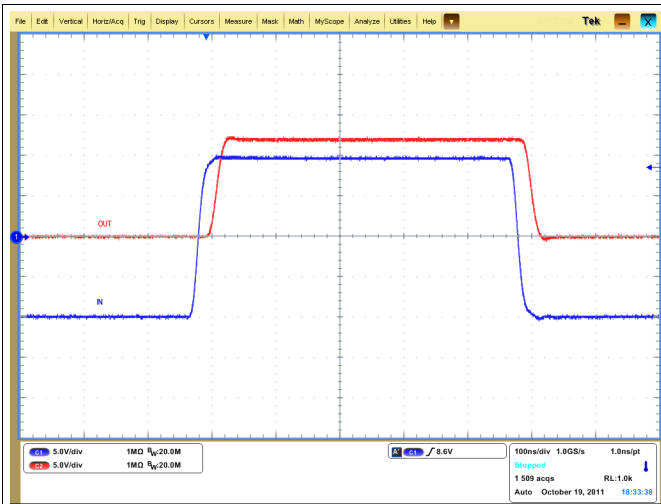

Figure 20. Negative 10-V Input

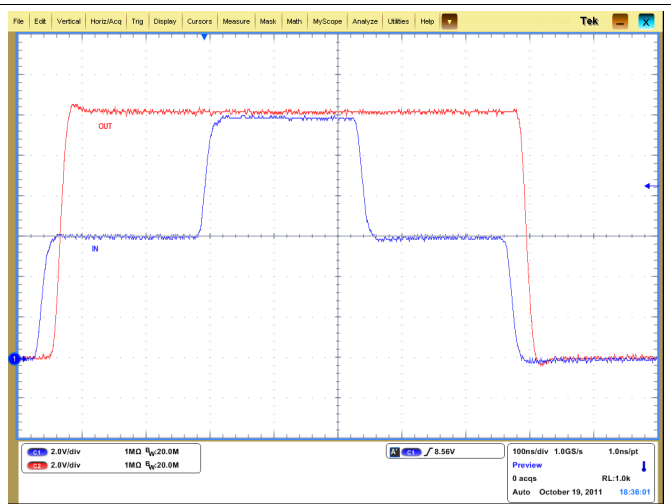

Figure 21. Step Input

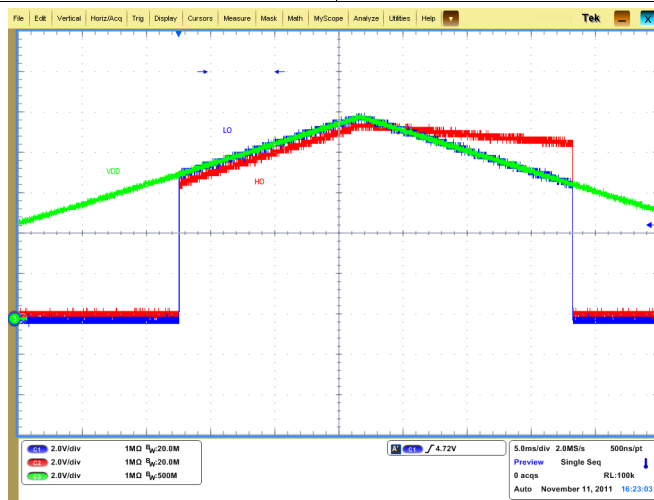

Figure 22. Symmetrical UVLO

9 Power Supply Recommendations

The bias supply voltage range for which the UCC27212A-Q1 device is recommended to operate is from 7 V to 17 V. The lower end of this range is governed by the internal undervoltage-lockout (UVLO) protection feature on the V_{DD} pin supply circuit blocks. Whenever the driver is in UVLO condition when the V_{DD} pin voltage is below the $V_{(ON)}$ supply start threshold, this feature holds the output low, regardless of the status of the inputs. The upper end of this range is driven by the 20-V absolute maximum voltage rating of the V_{DD} pin of the device (which is a stress rating). Keeping a 3-V margin to allow for transient voltage spikes, the maximum recommended voltage for the V_{DD} pin is 17 V. The UVLO protection feature also involves a hysteresis function, which means that when the V_{DD} pin bias voltage has exceeded the threshold voltage and device begins to operate, and if the voltage drops, then the device continues to deliver normal functionality unless the voltage drop exceeds the hysteresis specification $V_{DD(hys)}$. Therefore, ensuring that, while operating at or near the 7 V range, the voltage ripple on the auxiliary power supply output is smaller than the hysteresis specification of the device is important to avoid triggering device shutdown. During system shutdown, the device operation continues until the V_{DD} pin voltage has dropped below the $V_{(OFF)}$ threshold, which must be accounted for while evaluating system shutdown timing design requirements. Likewise, at system start-up the device does not begin operation until the V_{DD} pin voltage has exceeded the $V_{(ON)}$ threshold.

The quiescent current consumed by the internal circuit blocks of the device is supplied through the V_{DD} pin. Although this fact is well known, it is important to recognize that the charge for source current pulses delivered by the HO pin is also supplied through the same V_{DD} pin. As a result, every time a current is sourced out of the HO pin, a corresponding current pulse is delivered into the device through the V_{DD} pin. Thus, ensure that a local bypass capacitor is provided between the V_{DD} and GND pins and located as close to the device as possible for the purpose of decoupling is important. A low-ESR, ceramic surface-mount capacitor is required. TI recommends using a capacitor in the range 0.22 μF to 4.7 μF between V_{DD} and GND. In a similar manner, the current pulses delivered by the HO pin are sourced from the HB pin. Therefore a 0.022- μF to 0.1- μF local decoupling capacitor is recommended between the HB and HS pins.

10 Layout

10.1 Layout Guidelines

To improve the switching characteristics and efficiency of a design, the following layout rules must be followed.

- Locate the driver as close as possible to the MOSFETs.
- Locate the $V_{DD} - V_{SS}$ and $V_{HB} - V_{HS}$ (bootstrap) capacitors as close as possible to the device (see).
- Pay close attention to the GND trace. Use the thermal pad of the package as GND by connecting it to the VSS pin (GND). The GND trace from the driver goes directly to the source of the MOSFET, but must not be in the high current path of the MOSFET drain or source current.
- Use similar rules for the HS node as for GND for the high-side driver.
- For systems using multiple UCC27212A-Q1 devices, TI recommends that dedicated decoupling capacitors be located at $V_{DD} - V_{SS}$ for each device.
- Care must be taken to avoid placing VDD traces close to LO, HS, and HO signals.
- Use wide traces for LO and HO closely following the associated GND or HS traces. A width of 60 to 100 mils is preferable where possible.
- Use as least two or more vias if the driver outputs or SW node must be routed from one layer to another. For GND, the number of vias must be a consideration of the thermal pad requirements as well as parasitic inductance.
- Avoid LI and HI (driver input) going close to the HS node or any other high dV/dT traces that can induce significant noise into the relatively high impedance leads.

A poor layout can cause a significant drop in efficiency or system malfunction, and it can even lead to decreased reliability of the whole system.

10.2 Layout Example

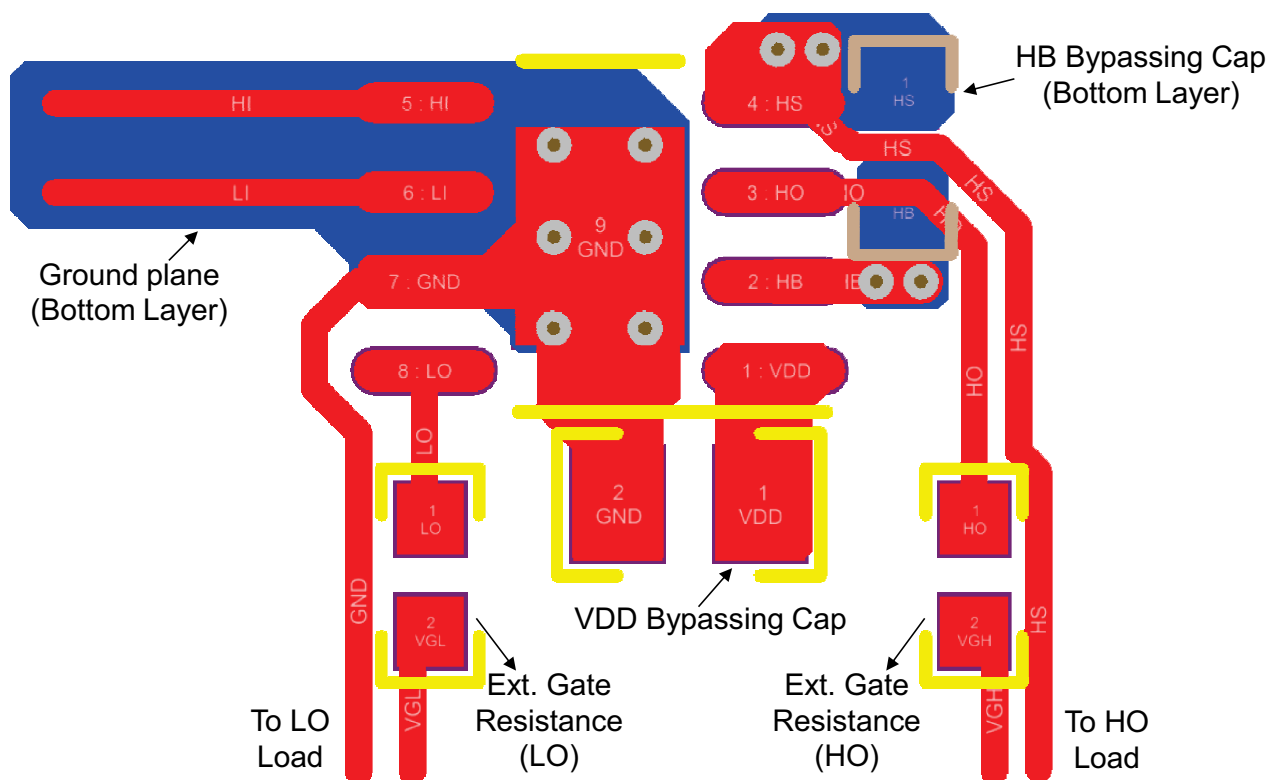

Figure 23. UCC27212A-Q1 Layout Example

10.2.1 Thermal Considerations

The useful range of a driver is greatly affected by the drive-power requirements of the load and the thermal characteristics of the package. For a gate driver to be useful over a particular temperature range, the package must allow for efficient removal of the heat produced while keeping the junction temperature within rated limits. The thermal metrics for the driver package are listed in . For detailed information regarding the table, refer to the Application Note from Texas Instruments entitled *Semiconductor and IC Package Thermal Metrics (SPRA953)*. The UCC27212A-Q1 device is offered in SOIC (8) and VSON (8). The section lists the thermal performance metrics related to the SOT-23 package.

11 Device and Documentation Support

11.1 Documentation Support

11.1.1 Related Documentation

For related documentation see the following:

- [PowerPAD™ Thermally Enhanced Package](#), Application Report
- [PowerPAD™ Made Easy](#), Application Report

11.2 Receiving Notification of Documentation Updates

To receive notification of documentation updates, navigate to the device product folder on ti.com. In the upper right corner, click on *Alert me* to register and receive a weekly digest of any product information that has changed. For change details, review the revision history included in any revised document.

11.3 Community Resources

The following links connect to TI community resources. Linked contents are provided "AS IS" by the respective contributors. They do not constitute TI specifications and do not necessarily reflect TI's views; see TI's [Terms of Use](#).

TI E2E™ Online Community *TI's Engineer-to-Engineer (E2E) Community*. Created to foster collaboration among engineers. At e2e.ti.com, you can ask questions, share knowledge, explore ideas and help solve problems with fellow engineers.

Design Support *TI's Design Support* Quickly find helpful E2E forums along with design support tools and contact information for technical support.

11.4 Trademarks

E2E is a trademark of Texas Instruments.

All other trademarks are the property of their respective owners.

11.5 Electrostatic Discharge Caution



This integrated circuit can be damaged by ESD. Texas Instruments recommends that all integrated circuits be handled with appropriate precautions. Failure to observe proper handling and installation procedures can cause damage.

ESD damage can range from subtle performance degradation to complete device failure. Precision integrated circuits may be more susceptible to damage because very small parametric changes could cause the device not to meet its published specifications.

11.6 Glossary

[SLYZ022](#) — *TI Glossary*.

This glossary lists and explains terms, acronyms, and definitions.

12 Mechanical, Packaging, and Orderable Information

The following pages include mechanical, packaging, and orderable information. This information is the most current data available for the designated devices. This data is subject to change without notice and revision of this document. For browser-based versions of this data sheet, refer to the left-hand navigation.

PACKAGING INFORMATION

Orderable Device	Status (1)	Package Type	Package Drawing	Pins	Package Qty	Eco Plan (2)	Lead/Ball Finish (6)	MSL Peak Temp (3)	Op Temp (°C)	Device Marking (4/5)	Samples
UCC27212AQDDARQ1	ACTIVE	SO PowerPAD	DDA	8	2500	Green (RoHS & no Sb/Br)	CU NIPDAUAG	Level-2-260C-1 YEAR	-40 to 140	27212Q	Samples

(1) The marketing status values are defined as follows:

ACTIVE: Product device recommended for new designs.

LIFEBUY: TI has announced that the device will be discontinued, and a lifetime-buy period is in effect.

NRND: Not recommended for new designs. Device is in production to support existing customers, but TI does not recommend using this part in a new design.

PREVIEW: Device has been announced but is not in production. Samples may or may not be available.

OBSOLETE: TI has discontinued the production of the device.

(2) **RoHS:** TI defines "RoHS" to mean semiconductor products that are compliant with the current EU RoHS requirements for all 10 RoHS substances, including the requirement that RoHS substance do not exceed 0.1% by weight in homogeneous materials. Where designed to be soldered at high temperatures, "RoHS" products are suitable for use in specified lead-free processes. TI may reference these types of products as "Pb-Free".

RoHS Exempt: TI defines "RoHS Exempt" to mean products that contain lead but are compliant with EU RoHS pursuant to a specific EU RoHS exemption.

Green: TI defines "Green" to mean the content of Chlorine (Cl) and Bromine (Br) based flame retardants meet JS709B low halogen requirements of <=1000ppm threshold. Antimony trioxide based flame retardants must also meet the <=1000ppm threshold requirement.

(3) MSL, Peak Temp. - The Moisture Sensitivity Level rating according to the JEDEC industry standard classifications, and peak solder temperature.

(4) There may be additional marking, which relates to the logo, the lot trace code information, or the environmental category on the device.

(5) Multiple Device Markings will be inside parentheses. Only one Device Marking contained in parentheses and separated by a "~" will appear on a device. If a line is indented then it is a continuation of the previous line and the two combined represent the entire Device Marking for that device.

(6) Lead/Ball Finish - Orderable Devices may have multiple material finish options. Finish options are separated by a vertical ruled line. Lead/Ball Finish values may wrap to two lines if the finish value exceeds the maximum column width.

Important Information and Disclaimer:The information provided on this page represents TI's knowledge and belief as of the date that it is provided. TI bases its knowledge and belief on information provided by third parties, and makes no representation or warranty as to the accuracy of such information. Efforts are underway to better integrate information from third parties. TI has taken and continues to take reasonable steps to provide representative and accurate information but may not have conducted destructive testing or chemical analysis on incoming materials and chemicals. TI and TI suppliers consider certain information to be proprietary, and thus CAS numbers and other limited information may not be available for release.

In no event shall TI's liability arising out of such information exceed the total purchase price of the TI part(s) at issue in this document sold by TI to Customer on an annual basis.

DDA (R-PDSO-G8)

PowerPAD™ PLASTIC SMALL-OUTLINE

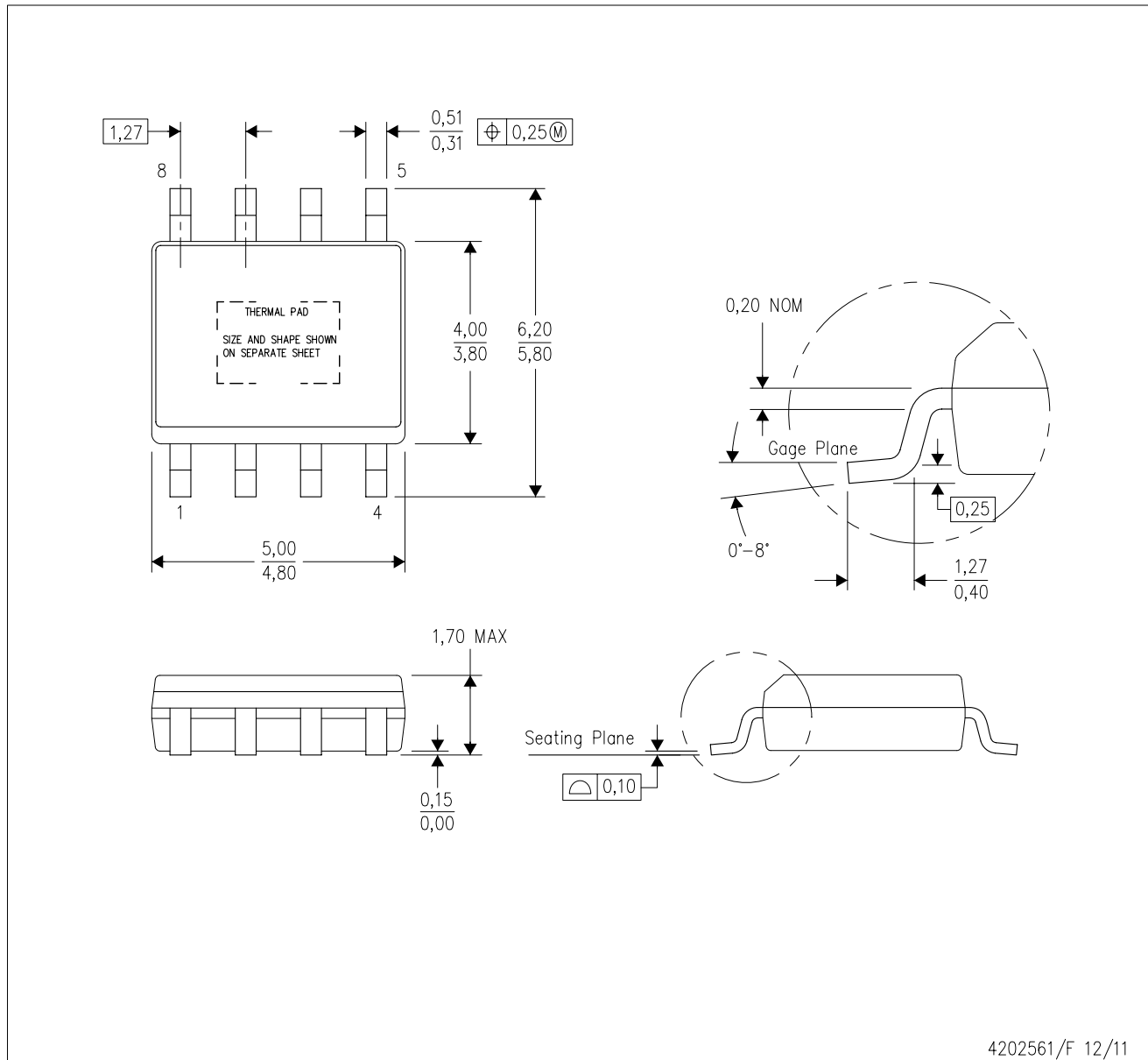

4202561/F 12/11

- NOTES:
- All linear dimensions are in millimeters. Dimensioning and tolerancing per ASME Y14.5-1994.
 - This drawing is subject to change without notice.
 - Body dimensions do not include mold flash or protrusion not to exceed 0,15.
 - This package is designed to be soldered to a thermal pad on the board. Refer to Technical Brief, PowerPad Thermally Enhanced Package, Texas Instruments Literature No. SLMA002 for information regarding recommended board layout. This document is available at www.ti.com <<http://www.ti.com>>.
 - See the additional figure in the Product Data Sheet for details regarding the exposed thermal pad features and dimensions.
 - This package complies to JEDEC MS-012 variation BA

PowerPAD is a trademark of Texas Instruments.

DDA (R-PDSO-G8)

PowerPAD™ PLASTIC SMALL OUTLINE

THERMAL INFORMATION

This PowerPAD™ package incorporates an exposed thermal pad that is designed to be attached to a printed circuit board (PCB). The thermal pad must be soldered directly to the PCB. After soldering, the PCB can be used as a heatsink. In addition, through the use of thermal vias, the thermal pad can be attached directly to the appropriate copper plane shown in the electrical schematic for the device, or alternatively, can be attached to a special heatsink structure designed into the PCB. This design optimizes the heat transfer from the integrated circuit (IC).

For additional information on the PowerPAD package and how to take advantage of its heat dissipating abilities, refer to Technical Brief, PowerPAD Thermally Enhanced Package, Texas Instruments Literature No. SLMA002 and Application Brief, PowerPAD Made Easy, Texas Instruments Literature No. SLMA004. Both documents are available at www.ti.com.

The exposed thermal pad dimensions for this package are shown in the following illustration.



Exposed Thermal Pad Dimensions

4206322-6/L 05/12

NOTE: A. All linear dimensions are in millimeters

PowerPAD is a trademark of Texas Instruments

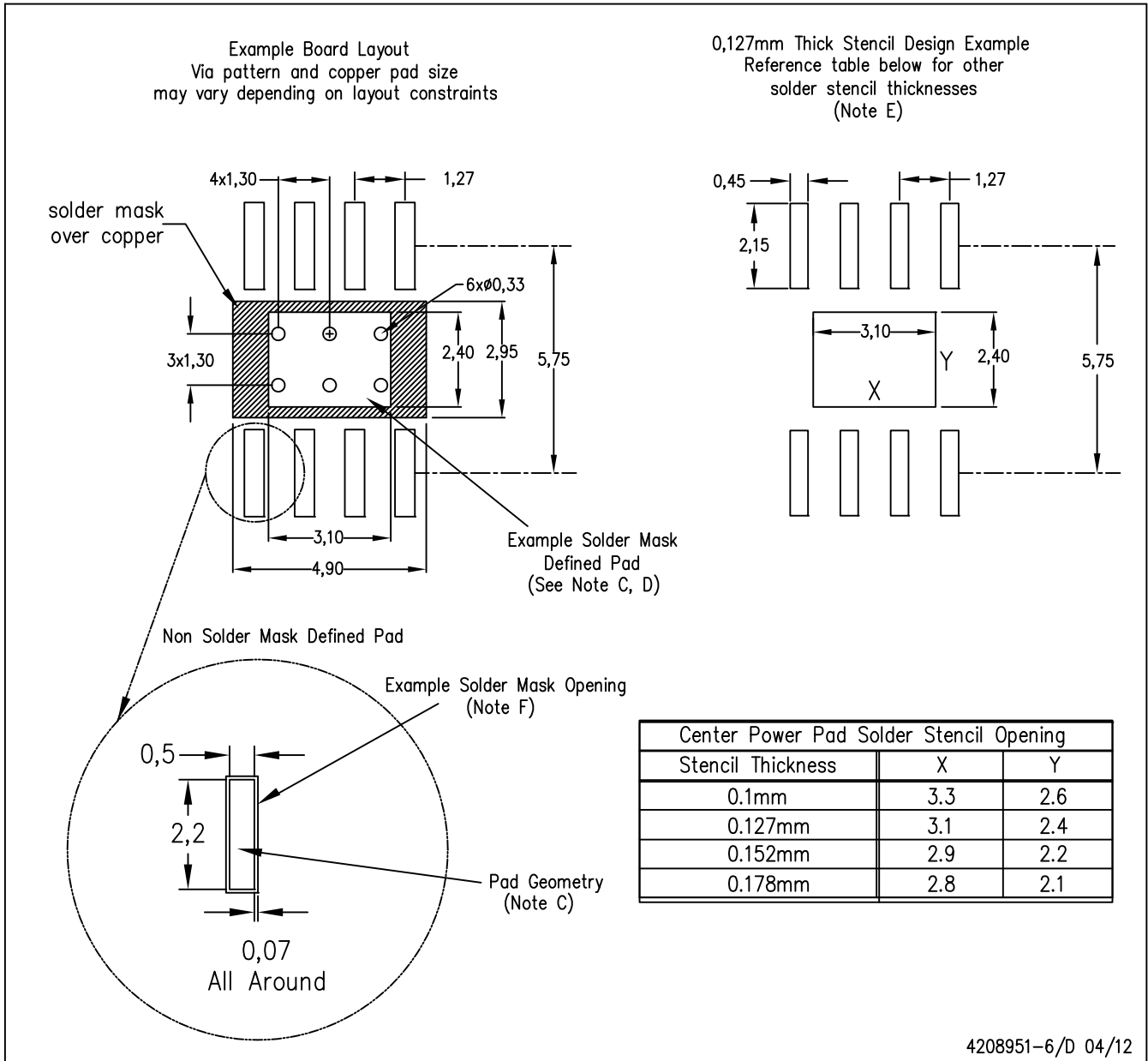

- NOTES:
- A. All linear dimensions are in millimeters.
 - B. This drawing is subject to change without notice.
 - C. Publication IPC-7351 is recommended for alternate designs.
 - D. This package is designed to be soldered to a thermal pad on the board. Refer to Technical Brief, PowerPad Thermally Enhanced Package, Texas Instruments Literature No. SLMA002, SLMA004, and also the Product Data Sheets for specific thermal information, via requirements, and recommended board layout. These documents are available at www.ti.com <<http://www.ti.com>>. Publication IPC-7351 is recommended for alternate designs.
 - E. Laser cutting apertures with trapezoidal walls and also rounding corners will offer better paste release. Customers should contact their board assembly site for stencil design recommendations. Example stencil design based on a 50% volumetric metal load solder paste. Refer to IPC-7525 for other stencil recommendations.
 - F. Customers should contact their board fabrication site for solder mask tolerances between and around signal pads.

PowerPAD is a trademark of Texas Instruments.

IMPORTANT NOTICE

Texas Instruments Incorporated (TI) reserves the right to make corrections, enhancements, improvements and other changes to its semiconductor products and services per JESD46, latest issue, and to discontinue any product or service per JESD48, latest issue. Buyers should obtain the latest relevant information before placing orders and should verify that such information is current and complete.

TI's published terms of sale for semiconductor products (<http://www.ti.com/sc/docs/stdterms.htm>) apply to the sale of packaged integrated circuit products that TI has qualified and released to market. Additional terms may apply to the use or sale of other types of TI products and services.

Reproduction of significant portions of TI information in TI data sheets is permissible only if reproduction is without alteration and is accompanied by all associated warranties, conditions, limitations, and notices. TI is not responsible or liable for such reproduced documentation. Information of third parties may be subject to additional restrictions. Resale of TI products or services with statements different from or beyond the parameters stated by TI for that product or service voids all express and any implied warranties for the associated TI product or service and is an unfair and deceptive business practice. TI is not responsible or liable for any such statements.

Buyers and others who are developing systems that incorporate TI products (collectively, "Designers") understand and agree that Designers remain responsible for using their independent analysis, evaluation and judgment in designing their applications and that Designers have full and exclusive responsibility to assure the safety of Designers' applications and compliance of their applications (and of all TI products used in or for Designers' applications) with all applicable regulations, laws and other applicable requirements. Designer represents that, with respect to their applications, Designer has all the necessary expertise to create and implement safeguards that (1) anticipate dangerous consequences of failures, (2) monitor failures and their consequences, and (3) lessen the likelihood of failures that might cause harm and take appropriate actions. Designer agrees that prior to using or distributing any applications that include TI products, Designer will thoroughly test such applications and the functionality of such TI products as used in such applications.

TI's provision of technical, application or other design advice, quality characterization, reliability data or other services or information, including, but not limited to, reference designs and materials relating to evaluation modules, (collectively, "TI Resources") are intended to assist designers who are developing applications that incorporate TI products; by downloading, accessing or using TI Resources in any way, Designer (individually or, if Designer is acting on behalf of a company, Designer's company) agrees to use any particular TI Resource solely for this purpose and subject to the terms of this Notice.

TI's provision of TI Resources does not expand or otherwise alter TI's applicable published warranties or warranty disclaimers for TI products, and no additional obligations or liabilities arise from TI providing such TI Resources. TI reserves the right to make corrections, enhancements, improvements and other changes to its TI Resources. TI has not conducted any testing other than that specifically described in the published documentation for a particular TI Resource.

Designer is authorized to use, copy and modify any individual TI Resource only in connection with the development of applications that include the TI product(s) identified in such TI Resource. NO OTHER LICENSE, EXPRESS OR IMPLIED, BY ESTOPPEL OR OTHERWISE TO ANY OTHER TI INTELLECTUAL PROPERTY RIGHT, AND NO LICENSE TO ANY TECHNOLOGY OR INTELLECTUAL PROPERTY RIGHT OF TI OR ANY THIRD PARTY IS GRANTED HEREIN, including but not limited to any patent right, copyright, mask work right, or other intellectual property right relating to any combination, machine, or process in which TI products or services are used. Information regarding or referencing third-party products or services does not constitute a license to use such products or services, or a warranty or endorsement thereof. Use of TI Resources may require a license from a third party under the patents or other intellectual property of the third party, or a license from TI under the patents or other intellectual property of TI.

TI RESOURCES ARE PROVIDED "AS IS" AND WITH ALL FAULTS. TI DISCLAIMS ALL OTHER WARRANTIES OR REPRESENTATIONS, EXPRESS OR IMPLIED, REGARDING RESOURCES OR USE THEREOF, INCLUDING BUT NOT LIMITED TO ACCURACY OR COMPLETENESS, TITLE, ANY EPIDEMIC FAILURE WARRANTY AND ANY IMPLIED WARRANTIES OF MERCHANTABILITY, FITNESS FOR A PARTICULAR PURPOSE, AND NON-INFRINGEMENT OF ANY THIRD PARTY INTELLECTUAL PROPERTY RIGHTS. TI SHALL NOT BE LIABLE FOR AND SHALL NOT DEFEND OR INDEMNIFY DESIGNER AGAINST ANY CLAIM, INCLUDING BUT NOT LIMITED TO ANY INFRINGEMENT CLAIM THAT RELATES TO OR IS BASED ON ANY COMBINATION OF PRODUCTS EVEN IF DESCRIBED IN TI RESOURCES OR OTHERWISE. IN NO EVENT SHALL TI BE LIABLE FOR ANY ACTUAL, DIRECT, SPECIAL, COLLATERAL, INDIRECT, PUNITIVE, INCIDENTAL, CONSEQUENTIAL OR EXEMPLARY DAMAGES IN CONNECTION WITH OR ARISING OUT OF TI RESOURCES OR USE THEREOF, AND REGARDLESS OF WHETHER TI HAS BEEN ADVISED OF THE POSSIBILITY OF SUCH DAMAGES.

Unless TI has explicitly designated an individual product as meeting the requirements of a particular industry standard (e.g., ISO/TS 16949 and ISO 26262), TI is not responsible for any failure to meet such industry standard requirements.

Where TI specifically promotes products as facilitating functional safety or as compliant with industry functional safety standards, such products are intended to help enable customers to design and create their own applications that meet applicable functional safety standards and requirements. Using products in an application does not by itself establish any safety features in the application. Designers must ensure compliance with safety-related requirements and standards applicable to their applications. Designer may not use any TI products in life-critical medical equipment unless authorized officers of the parties have executed a special contract specifically governing such use. Life-critical medical equipment is medical equipment where failure of such equipment would cause serious bodily injury or death (e.g., life support, pacemakers, defibrillators, heart pumps, neurostimulators, and implantables). Such equipment includes, without limitation, all medical devices identified by the U.S. Food and Drug Administration as Class III devices and equivalent classifications outside the U.S.

TI may expressly designate certain products as completing a particular qualification (e.g., Q100, Military Grade, or Enhanced Product). Designers agree that it has the necessary expertise to select the product with the appropriate qualification designation for their applications and that proper product selection is at Designers' own risk. Designers are solely responsible for compliance with all legal and regulatory requirements in connection with such selection.

Designer will fully indemnify TI and its representatives against any damages, costs, losses, and/or liabilities arising out of Designer's non-compliance with the terms and provisions of this Notice.