

UCC21750-Q1 10-A Source/Sink Reinforced Isolated Single Channel Gate Driver for SiC/IGBT with Active Protection, Isolated Analog Sensing and High-CMTI

1 Features

- 5.7-kV_{RMS} single channel isolated gate driver
- AEC-Q100 qualified for automotive applications
- SiC MOSFETs and IGBTs up to 2121V_{pk}
- 33-V maximum output drive voltage (VDD-VEE)
- ±10-A drive strength and split output
- 150-V/ns minimum CMTI
- 200ns response time fast DESAT protection
- 4-A Internal active miller clamp
- 400mA soft turn-off when fault happens
- Isolated analog sensor with PWM output for
 - Temperature sensing with NTC, PTC or thermal diode
 - High voltage DC-Link or phase voltage
- Alarm $\overline{\text{FLT}}$ on over current and reset from $\overline{\text{RST/EN}}$
- Fast enable/disable response on $\overline{\text{RST/EN}}$
- Reject <40ns noise transient and pulse on input pins
- 12V VDD UVLO with power good on RDY
- Inputs/outputs with over/under-shoot transient voltage Immunity up to 5 V
- 130-ns (maximum) propagation delay and 30-ns (maximum) pulse/part skew
- SOIC-16 DW package with creepage and clearance distance > 8mm
- Operating junction temperature –40°C to 150°C

2 Applications

- Traction inverter for EVs
- On-board charger and charging pile
- DC/DC Converter for HEV/EVs

3 Description

The UCC21750-Q1 is a galvanic isolated single channel gate driver designed for SiC MOSFETs and IGBTs up to 2121-V DC operating voltage with advanced protection features, best-in-class dynamic performance and robustness. UCC21750-Q1 has up to ±10-A peak source and sink current.

The input side is isolated from the output side with SiO₂ capacitive isolation technology, supporting up to 1.5-kV_{RMS} working voltage, 12.8-kV_{PK} surge immunity with longer than 40 years Isolation barrier life, as well as providing low part-to-part skew, >150V/ns common mode noise immunity (CMTI).

The UCC21750-Q1 includes the state-of-art protection features, such as fast overcurrent and short circuit detection, shunt current sensing support, fault reporting, active miller clamp, input and output side power supply UVLO to optimize SiC and IGBT switching behavior and robustness. The isolated analog to PWM sensor can be utilized for easier temperature or voltage sensing, further increasing the drivers' versatility and simplifying the system design effort, size and cost.

Device Information⁽¹⁾

| PART NUMBER | PACKAGE | BODY SIZE (NOM) |
|-------------|------------|------------------|
| UCC21750-Q1 | DW SOIC-16 | 10.3 mm × 7.5 mm |

(1) For all available packages, see the orderable addendum at the end of the data sheet.

Device Pin Configuration

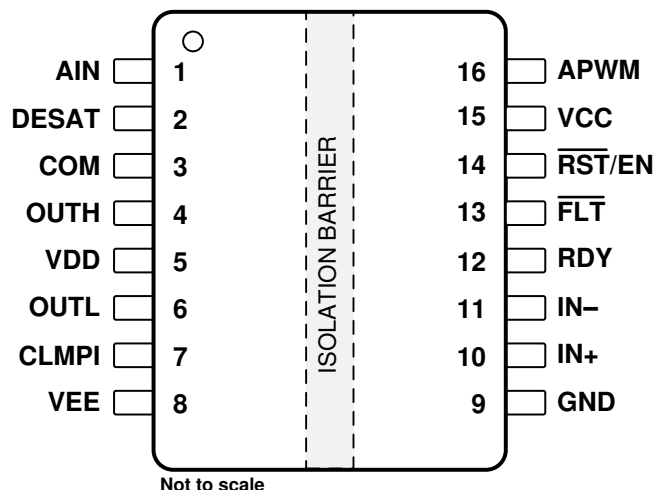

Table of Contents

| | | | |
|--|-----------|--|-----------|
| 1 Features | 1 | 7.4 Under Voltage Lockout (UVLO) | 19 |
| 2 Applications | 1 | 7.5 Desaturation (DESAT) Protection | 21 |
| 3 Description | 1 | 8 Detailed Description | 23 |
| 4 Revision History | 2 | 8.1 Overview | 23 |
| 5 Pin Configuration and Functions | 3 | 8.2 Functional Block Diagram | 24 |
| 6 Specifications | 5 | 8.3 Feature Description | 24 |
| 6.1 Absolute Maximum Ratings | 5 | 8.4 Device Functional Modes | 31 |
| 6.2 ESD Ratings | 5 | 9 Applications and Implementation | 32 |
| 6.3 Recommended Operating Conditions | 5 | 9.1 Application Information | 32 |
| 6.4 Thermal Information | 5 | 9.2 Typical Application | 32 |
| 6.5 Power Ratings | 6 | 10 Power Supply Recommendations | 43 |
| 6.6 Insulation Specifications | 7 | 11 Layout | 44 |
| 6.7 Safety-Related Certifications | 8 | 11.1 Layout Guidelines | 44 |
| 6.8 Safety Limiting Values | 8 | 11.2 Layout Example | 45 |
| 6.9 Electrical Characteristics | 9 | 12 Device and Documentation Support | 46 |
| 6.10 Switching Characteristics | 11 | 12.1 Documentation Support | 46 |
| 6.11 Insulation Characteristics Curves | 12 | 12.2 Receiving Notification of Documentation Updates | 46 |
| 6.12 Typical Characteristics | 13 | 12.3 Community Resource | 46 |
| 7 Parameter Measurement Information | 16 | 12.4 Trademarks | 46 |
| 7.1 Propagation Delay | 16 | 12.5 Electrostatic Discharge Caution | 46 |
| 7.2 Input Deglitch Filter | 17 | 12.6 Glossary | 46 |
| 7.3 Active Miller Clamp | 18 | 13 Mechanical, Packaging, and Orderable Information | 46 |

4 Revision History

NOTE: Page numbers for previous revisions may differ from page numbers in the current version.

| DATE | REVISION | NOTES |
|----------------|----------|-----------------------------|
| September 2019 | * | Advance Information release |

5 Pin Configuration and Functions

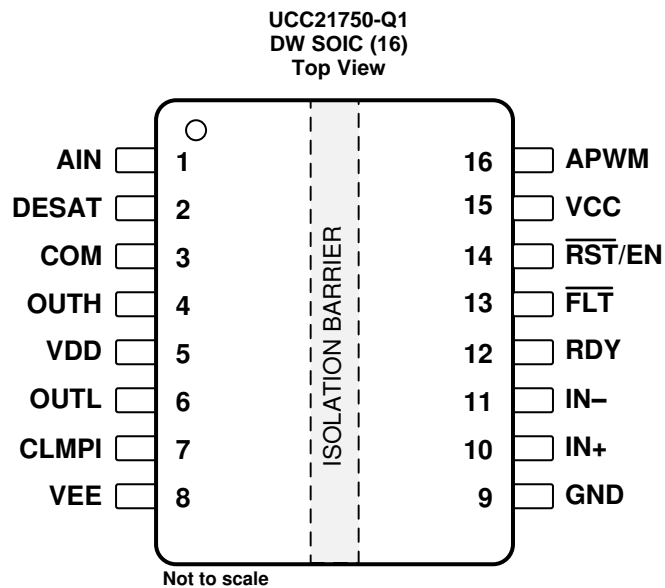

ADVANCE INFORMATION

Pin Functions

| PIN | | I/O ⁽¹⁾ | DESCRIPTION |
|----------------------------|-----|--------------------|--|
| NAME | NO. | | |
| AIN | 1 | I | Isolated analog sensing input, parallel a small capacitor to COM for better noise immunity |
| DESAT | 2 | I | Denaturation current protection input |
| COM | 3 | P | Common ground reference, connecting to emitter pin for IGBT and source pin for SiC-MOSFET |
| OUTH | 4 | O | Gate driver output pull up |
| VDD | 5 | P | Positive supply rail for gate drive voltage, Bypassing a >220nF capacitor to COM to support specified gate driver source peak current capability |
| OUTL | 6 | O | Gate driver output pull down |
| CLMPI | 7 | I | Internal Active miller clamp, connecting this pin directly to the gate of the power transistor |
| VEE | 8 | P | Negative supply rail for gate drive voltage. Bypassing a >220nF capacitor to COM to support specified gate driver sink peak current capability |
| GND | 9 | P | Input power supply and logic ground reference |
| IN+ | 10 | I | Non-inverting gate driver control input |
| IN- | 11 | I | Inverting gate driver control input |
| RDY | 12 | O | Power good for VCC-GND and VDD-COM. RDY is open drain configuration and can be paralleled with other RDY signals |
| $\overline{\text{FLT}}$ | 13 | O | Active low fault alarm output upon over current or short circuit. $\overline{\text{FLT}}$ is in open drain configuration and can be paralleled with other faults |
| $\overline{\text{RST/EN}}$ | 14 | I | The $\overline{\text{RST/EN}}$ serves two purposes: 1) Enable / shutdown of the output side. The FET is turned off by a general turn-off, if terminal EN is set to low; 2) Resets the DESAT condition signaled on $\overline{\text{FLT}}$ pin. if terminal $\overline{\text{RST/EN}}$ is set to low for more than 1000ns. A reset of signal $\overline{\text{FLT}}$ is asserted at the rising edge of terminal $\overline{\text{RST/EN}}$. For automatic RESET function, this pin only serves as an EN pin. Enable / shutdown of the output side. The FET is turned off by a general turn-off, if terminal EN is set to low. |
| VCC | 15 | P | Input power supply from 3V to 5.5V, bypassing a >100nF capacitor to GND |
| APWM | 16 | O | Isolated Analog Sensing PWM output |

(1) P = Power, G = Ground, I = Input, O = Output

6 Specifications

6.1 Absolute Maximum Ratings

over operating free-air temperature range (unless otherwise noted)⁽¹⁾

| PARAMETER | | MIN | MAX | UNIT | |
|--|---|--|---------|---------|---|
| VCC | VCC – GND | –0.3 | 6 | V | |
| VDD | VDD – COM | –0.3 | 36 | V | |
| VEE | VEE – COM | –17.5 | 0.3 | V | |
| V _{MAX} | VDD – VEE | –0.3 | 36 | V | |
| IN+, IN–, $\overline{\text{RST}}/\text{EN}$ | | DC | GND–0.3 | VCC | V |
| | | Transient, less than 100 ns ⁽²⁾ | GND–5.0 | VCC+5.0 | V |
| DESAT | Reference to COM | COM–0.3 | VDD+0.3 | V | |
| AIN | Reference to COM | –0.3 | 5 | V | |
| OUTH, OUTL, CLMPI | | DC | VEE–0.3 | VDD | V |
| | | Transient, less than 100 ns ⁽²⁾ | VEE–5.0 | VDD+5.0 | V |
| CLMPE | Reference to VEE | –0.3 | 5 | V | |
| RDY, $\overline{\text{FLT}}$, APWM | | GND–0.3 | VCC | V | |
| I _{$\overline{\text{FLT}}$} , I _{RDY} | $\overline{\text{FLT}}$, and RDY pin input current | | 20 | mA | |
| I _{APWM} | APWM pin output current | | 20 | mA | |
| T _J | Junction temperature range | –40 | 150 | °C | |
| T _{stg} | Storage temperature range | –65 | 150 | °C | |

- (1) Stresses beyond those listed under *absolute maximum ratings* may cause permanent damage to the device. These are stress ratings only and functional operation of the device at these or any other conditions beyond those indicated under *recommended operating conditions* is not implied. Exposure to absolute-maximum-rated conditions for extended periods may affect device reliability.
- (2) Values are verified by characterization on bench.

6.2 ESD Ratings

| | | VALUE | UNIT |
|--------------------|-------------------------|---|-------|
| V _(ESD) | Electrostatic discharge | Human-body model (HBM), per AEC Q100-002 ⁽¹⁾ | ±4000 |
| | | Charged-device model (CDM), per AEC Q100-011 | ±1500 |

- (1) AEC Q100-002 indicates that HBM stressing shall be in accordance with the ANSI/ESDA/JEDEC JS-001 specification.

6.3 Recommended Operating Conditions

| PARAMETER | | MIN | MAX | UNIT | |
|---|--|--------------------------|---------|---------|---|
| VCC | VCC–GND | 3.0 | 5.5 | V | |
| VDD | VDD–COM | 13 | 33 | V | |
| V _{MAX} | VDD–VEE | – | 33 | V | |
| IN+, IN–, $\overline{\text{RST}}/\text{EN}$ | Reference to GND | High level input voltage | 0.7×VCC | VCC | V |
| | | Low level input voltage | 0 | 0.3×VCC | |
| AIN | Reference to COM | 0.6 | 4.5 | V | |
| t _{RST/EN} | Minimum pulse width that reset the fault | 1000 | | ns | |
| T _A | Ambient Temperature | –40 | 125 | °C | |
| T _J | Junction temperature | –40 | 150 | °C | |

6.4 Thermal Information

| THERMAL METRIC ⁽¹⁾ | | UCC21750-Q1 | UNIT |
|-------------------------------|--|-------------|------|
| | | DW (SOIC) | |
| | | 16 | |
| R _{0JA} | Junction-to-ambient thermal resistance | 68.3 | °C/W |

- (1) For more information about traditional and new thermal metrics, see the [Semiconductor and IC Package Thermal Metrics](#) application report.

Thermal Information (continued)

| THERMAL METRIC ⁽¹⁾ | | UCC21750-Q1 | UNIT |
|-------------------------------|--|-------------|------|
| | | DW (SOIC) | |
| | | 16 | |
| $R_{\theta JC(top)}$ | Junction-to-case (top) thermal resistance | 27.5 | °C/W |
| $R_{\theta JB}$ | Junction-to-board thermal resistance | 32.9 | °C/W |
| Ψ_{JT} | Junction-to-top characterization parameter | 14.1 | °C/W |
| Ψ_{JB} | Junction-to-board characterization parameter | 32.3 | °C/W |

6.5 Power Ratings

| PARAMETER | | TEST CONDITIONS | Value | UNIT |
|-----------|---|---|-------|------|
| P_D | Maximum power dissipation (both sides) | VCC = 5V, VDD-COM = 20V, COM-VEE = 5V, IN+/- = 5V, 150kHz, 50% Duty Cycle for 10nF load, T _a =25°C | 985 | mW |
| P_{D1} | Maximum power dissipation by transmitter side | | 20 | mW |
| P_{D2} | Maximum power dissipation by receiver side | | 965 | mW |

6.6 Insulation Specifications

| PARAMETER | | TEST CONDITIONS | VALUE | UNIT |
|--|---|--|--------------------|------------------|
| GENERAL | | | | |
| CLR | External clearance ⁽¹⁾ | Shortest terminal-to-terminal distance through air | > 8 | mm |
| CPG | External creepage ⁽¹⁾ | Shortest terminal-to-terminal distance across the package surface | > 8 | mm |
| DTI | Distance through the insulation | Minimum internal gap (Internal clearance) of the double insulation (2 × 0.0085 mm) | > 17 | µm |
| CTI | Comparative tracking index | DIN EN 60112 (VDE 0303-11); IEC 60112 | > 600 | V |
| | Material group | According to IEC 60664-1 | I | |
| | Overvoltage Category per IEC 60664-1 | Rated mains voltage ≤ 300 V _{RMS} | I-IV | |
| | | Rated mains voltage ≤ 600 V _{RMS} | I-IV | |
| | | Rated mains voltage ≤ 1000 V _{RMS} | I-III | |
| DIN V VDE V 0884-11 (VDE V 0884-11):2017-01⁽²⁾ | | | | |
| V _{IORM} | Maximum repetitive peak isolation voltage | AC voltage (bipolar) | 2121 | V _{PK} |
| V _{IOWM} | Maximum isolation working voltage | AC voltage (sine wave) Time dependent dielectric breakdown (TDDB) test | 1500 | V _{RMS} |
| | | DC voltage | 2121 | V _{DC} |
| V _{IOTM} | Maximum transient isolation voltage | V _{TEST} =V _{IOTM} , t = 60 s (qualification test) | 8000 | V _{PK} |
| | | V _{TEST} =1.2 × V _{IOTM} , t = 1 s (100% production test) | 9600 | |
| V _{IOSM} | Maximum surge isolation voltage ⁽³⁾ | Test method per IEC 62368-1, 1.2/50 µs waveform, V _{TEST} = 1.6 × V _{IOSM} = 12800 V _{PK} (qualification) | 8000 | V _{PK} |
| q _{pd} | Apparent charge ⁽⁴⁾ | Method a: After I/O safety test subgroup 2/3, V _{ini} = V _{IOTM} , t _{ini} = 60 s; V _{pd(m)} = 1.2 × V _{IORM} = 2545 V _{PK} , t _m = 10 s | ≤ 5 | pC |
| | | Method a: After environmental tests subgroup 1, V _{ini} = V _{IOTM} , t _{ini} = 60 s; V _{pd(m)} = 1.6 × V _{IORM} = 3394 V _{PK} , t _m = 10 s | ≤ 5 | |
| | | Method b1: At routine test (100% production) and preconditioning (type test) V _{ini} = V _{IOTM} , t _{ini} = 1 s; V _{pd(m)} = 1.875 × V _{IORM} = 3977 V _{PK} , t _m = 1 s | ≤ 5 | |
| C _{IO} | Barrier capacitance, input to output ⁽⁵⁾ | V _{IO} = 0.5 sin (2πft), f = 1 MHz | ~ 1 | pF |
| R _{IO} | Insulation resistance, input to output ⁽⁵⁾ | V _{IO} = 500 V, T _A = 25°C | ≥ 10 ¹² | Ω |
| | | V _{IO} = 500 V, 100°C ≤ T _A ≤ 125°C | ≥ 10 ¹¹ | |
| | | V _{IO} = 500 V at T _S = 150°C | ≥ 10 ⁹ | |
| | Pollution degree | | 2 | |
| | Climatic category | | 40/125/21 | |
| UL 1577 | | | | |
| V _{ISO} | Withstand isolation voltage | V _{TEST} = V _{ISO} = 5700 V _{RMS} , t = 60 s (qualification); V _{TEST} = 1.2 × V _{ISO} = 6840 V _{RMS} , t = 1 s (100% production) | 5700 | V _{RMS} |

- (1) Apply creepage and clearance requirements according to the specific equipment isolation standards of an application. Care must be taken to maintain the creepage and clearance distance of a board design to ensure that the mounting pads of the isolator on the printed circuit board (PCB) do not reduce this distance. Creepage and clearance on a PCB become equal in certain cases. Techniques such as inserting grooves and ribs on the PCB are used to help increase these specifications.
- (2) This coupler is suitable for safe electrical insulation only within the safety ratings. Compliance with the safety ratings shall be ensured by means of suitable protective circuits.
- (3) Testing is carried out in air or oil to determine the intrinsic surge immunity of the isolation barrier.
- (4) Apparent charge is electrical discharge caused by a partial discharge (pd).
- (5) All pins on each side of the barrier tied together creating a two-terminal device

6.7 Safety-Related Certifications

| VDE | UL | CSA | CQC | TUV |
|--|--|---|---|---|
| Plan to certify according to DIN V VDE V 0884-11 (VDE V 0884-11):2017-01; DIN EN 61010-1 (VDE 0411-1):2011-07 | Plan to certify according to UL 1577 Component Recognition Program | Plan to certify according to CSA Component Acceptance Notice 5A, IEC 60950-1, and IEC 60601-1 | Plan to certify according to GB4943.1-2011 | Plan to certify according to EN 61010-1:2010 (3rd Ed) and EN 60950-1:2006/A11:2009/A1:2010/A12:2011/A2:2013 |
| Reinforced insulation Maximum transient isolation voltage, 8000 V _{PK} ; Maximum repetitive peak isolation voltage, 2121 V _{PK} ; Maximum surge isolation voltage, 8000 V _{PK} | Single protection, 5700 V _{RMS} | Isolation Rating of 5700 V _{RMS} ; Reinforced insulation per CSA 60950-1-07+A1+A2 and IEC 60950-1 (2nd Ed.), 1450 V _{RMS} max working voltage (pollution degree 2, material group I) ; 2 MOPP (Means of Patient Protection) per CSA 60601-1:14 and IEC 60601-1 Ed. 3.1, 250 V _{RMS} (354 V _{PK}) max working voltage | Reinforced Insulation, Altitude ≤ 5000m, Tropical climate, 400 V _{RMS} maximum working voltage | 5700 V _{RMS} Reinforced insulation per EN 61010-1:2010 (3rd Ed) up to working voltage of 1000 V _{RMS} 5700 V _{RMS} Reinforced insulation per EN 60950-1:2006/A11:2009/A1:2010/A12:2011/A2:2013 up to working voltage of 1450 V _{RMS} |
| Certification Planned | Certification Planned | Certification Planned | Certification Planned | Certification Planned |

6.8 Safety Limiting Values

The safety-limiting constraint is the maximum junction temperature specified in the data sheet. The power dissipation and junction-to-air thermal impedance of the device installed in the application hardware determines the junction temperature. The assumed junction-to-air thermal resistance in the *Thermal Information* table is that of a device installed on a high-K test board for leaded surface-mount packages. The power is the recommended maximum input voltage times the current. The junction temperature is then the ambient temperature plus the power times the junction-to-air thermal resistance. These limits vary with the ambient temperature, the junction-to-air thermal resistance, and the power supply voltages in different applications.

| PARAMETER | TEST CONDITIONS | MIN | TYP | MAX | UNIT |
|--|--|-----|-----|------|------|
| I _S Safety input, output, or supply current | R _{θJA} = 68.3°C/W, V _{DD} = 15V, V _{EE} = -5V, T _J = 150°C, T _A = 25°C | | | 91 | mA |
| | R _{θJA} = 68.3°C/W, V _{DD} = 20V, V _{EE} = -5V, T _J = 150°C, T _A = 25°C | | | 73 | |
| P _S Safety input, output, or total power | R _{θJA} = 68.3°C/W, V _{DD} = 20V, V _{EE} = -5V, T _J = 150°C, T _A = 25°C | | | 1830 | mW |
| T _S Safety temperature | | | | 150 | °C |

ADVANCE INFORMATION

6.9 Electrical Characteristics

VCC = 3.3 V or 5.0 V, 1- μ F capacitor from VCC to GND, VDD – COM = 20 V, 18 V or 15 V, COM – VEE = 0 V, 5 V, 8 V or 15 V, C_L = 100 pF, –40°C < T_J < 150°C (unless otherwise noted)⁽¹⁾⁽²⁾.

| PARAMETER | TEST CONDITIONS | MIN | TYP | MAX | UNIT | |
|---|--|--|------|-----------|------------|----|
| VCC UVLO THRESHOLD AND DELAY | | | | | | |
| V _{VCC_ON} | | 2.55 | 2.7 | 2.85 | V | |
| V _{VCC_OFF} | VCC–GND | 2.35 | 2.5 | 2.65 | | |
| V _{VCC_HYS} | | | 0.2 | | | |
| t _{VCCFIL} | VCC UVLO Deglitch time | | 10 | | μ s | |
| t _{VCC+ to OUT} | VCC UVLO on delay to output high | IN+ = VCC, IN– = GND | 37.8 | | | |
| t _{VCC– to OUT} | VCC UVLO off delay to output low | | 10 | | | |
| t _{VCC+ to RDY} | VCC UVLO on delay to RDY high | $\overline{\text{RST}}/\text{EN} = \text{VCC}$ | 37.8 | | | |
| t _{VCC– to RDY} | VCC UVLO off delay to RDY low | | 10 | | | |
| VDD UVLO THRESHOLD AND DELAY | | | | | | |
| V _{VDD_ON} | | 11.2 | 12.0 | 12.8 | V | |
| V _{VDD_OFF} | VDD–COM | 9.9 | 10.7 | 11.5 | | |
| V _{VDD_HYS} | | | 0.8 | | | |
| t _{VDDFIL} | VDD UVLO Deglitch time | | 5 | | μ s | |
| t _{VDD+ to OUT} | VDD UVLO on delay to output high | IN+ = VCC, IN– = GND | 5 | | | |
| t _{VDD– to OUT} | VDD UVLO off delay to output low | | 5 | | | |
| t _{VDD+ to RDY} | VDD UVLO on delay to RDY high | $\overline{\text{RST}}/\text{EN} = \overline{\text{FLT}} = \text{High}$ | 10 | | | |
| t _{VDD– to RDY} | VDD UVLO off delay to RDY low | | 10 | | | |
| VCC, VDD QUIESCENT CURRENT | | | | | | |
| I _{VCCQ} | VCC quiescent current | OUT(H) = High, f _S = 0Hz, AIN=2V | 3 | | mA | |
| | | OUT(L) = Low, f _S = 0Hz, AIN=2V | 2 | | | |
| I _{VDDQ} | VDD quiescent current | OUT(H) = High, f _S = 0Hz, AIN=2V | 4 | | mA | |
| | | OUT(L) = Low, f _S = 0Hz, AIN=2V | 3.7 | | | |
| LOGIC INPUTS — IN+, IN– and $\overline{\text{RST}}/\text{EN}$ | | | | | | |
| V _{INH} | Input high threshold | V _{CC} =3.3V | 1.85 | 2.31 | V | |
| V _{INL} | Input low threshold | V _{CC} =3.3V | 0.99 | 1.52 | V | |
| V _{INHYS} | Input threshold hysteresis | V _{CC} =3.3V | 0.33 | | V | |
| I _{IH} | Input high level input leakage current | V _{IN} = VCC | 90 | | μ A | |
| I _{IL} | Input low level input leakage | V _{IN} = GND | –90 | | μ A | |
| R _{IND} | Input pins pull down resistance | see Detailed Description for more information | 55 | | k Ω | |
| R _{INU} | Input pins pull up resistance | see Detailed Description for more information | 55 | | | |
| T _{INFIL} | IN+, IN– and $\overline{\text{RST}}/\text{EN}$ deglitch (ON and OFF) filter time | f _S = 50kHz | 28 | 40 | ns | |
| T _{RSTFIL} | Deglitch filter time to reset /FLT | | 500 | 650 | 800 | ns |
| GATE DRIVER STAGE | | | | | | |
| I _{OUT} , I _{OUTH} | Peak source current | C _L =0.18 μ F, f _S =1kHz | –10 | | A | |
| I _{OUT} , I _{OUTL} | Peak sink current | | 10 | | A | |
| R _{OUTH} | Output pull-up resistance | I _{OUT} = –0.1A | 2.5 | | Ω | |
| R _{OUTL} | Output pull-down resistance | I _{OUT} = 0.1A | 0.3 | | Ω | |
| V _{OUTH} | High level output voltage | I _{OUT} = –0.2A, V _{DD} =15V | 14.5 | | V | |
| V _{OUTL} | Low level output voltage | I _{OUT} = 0.2A | 60 | | mV | |
| ACTIVE PULLDOWN | | | | | | |
| V _{OUTPD} | Output active pull down on OUT, OUTL | I _{OUTL} or I _{OUT} = 0.1 × I _{OUT(L)(typ)} , VDD=OPEN, VEE=COM | | 2.5 | V | |
| INTERNAL ACTIVE MILLER CLAMP | | | | | | |
| V _{CLMPH} | Miller clamp threshold voltage | Reference to VEE | 1.7 | 2.0 | 2.3 | V |
| V _{CLMPI} | Output low clamp voltage | I _{CLMPI} = 1A | | VEE + 0.5 | | V |

(1) Current are positive into and negative out of the specified terminal.

(2) All voltages are referenced to COM unless otherwise notified.

Electrical Characteristics (continued)

VCC = 3.3 V or 5.0 V, 1- μ F capacitor from VCC to GND, VDD – COM = 20 V, 18 V or 15 V, COM – VEE = 0 V, 5 V, 8 V or 15 V, C_L = 100 pF, -40°C < T_J < 150°C (unless otherwise noted)⁽¹⁾⁽²⁾.

| PARAMETER | | TEST CONDITIONS | MIN | TYP | MAX | UNIT |
|--|---|---|------|-----|-----|----------|
| I _{CLMPI} | Output low clamp current | V _{CLMPI} = 0V, VEE = -2.5V | | 4 | | A |
| R _{CLMPI} | Miller clamp pull down resistance | I _{CLMPI} = 0.2A | | 0.6 | | Ω |
| t _{DCLMPI} | Miller clamp ON delay time | C _L = 1.8nF | | 25 | 50 | ns |
| SHORT CIRCUIT CLAMPING | | | | | | |
| V _{CLP-OUT(H)} | V _{OUT} -VDD, V _{OUTH} -VDD | OUT = Low, I _{OUT(H)} = 500mA, t _{CLP} =10us | | 0.9 | | V |
| V _{CLP-OUT(L)} | V _{OUT} -VDD, V _{OUTL} -VDD | OUT = High, I _{OUT(L)} = 500mA, t _{CLP} =10us | | 1.8 | | V |
| V _{CLP-CLMPI} | V _{CLMPI} -VDD | OUT = High, I _{CLMPI} = -20mA, t _{CLP} =10us | | 1.0 | | V |
| DESAT PROTECTION | | | | | | |
| I _{CHG} | Blanking capacitor charge current | V _{DESAT} = 2.0V | 450 | 500 | 550 | μ A |
| I _{DCHG} | Blanking capacitor discharge current | V _{DESAT} = 6.0V | 10 | 15 | | mA |
| V _{DESAT} | Detection Threshold | | 8.5 | 9.0 | 9.5 | V |
| V _{DESATL} | Voltage when OUT(L) = LOW, Reference to COM | I _{DESAT} = 15mA | | | 1 | V |
| t _{DESATLEB} | Leading edge blank time | | | 200 | | ns |
| t _{DESATFIL} | DESAT deglitch filter | | | 150 | | ns |
| t _{DESATOFF} | DESAT propagation delay to OUT(L) 90% | | | 200 | | ns |
| t _{DESATFLT} | DESAT to $\overline{\text{FLT}}$ low delay | | | 600 | | ns |
| INTERNAL SOFT TURN-OFF | | | | | | |
| I _{STO} | Soft turn-off current on fault conditions | | | 400 | | mA |
| ISOLATED TEMPERATURE SENSE AND MONITOR (AIN-APWM) | | | | | | |
| V _{AIN} | Analog sensing voltage range | | 0.5 | | 4.5 | V |
| I _{AIN} | Internal current source | V _{AIN} =2.5V, -40°C < T _J < 150°C | 196 | 200 | 206 | μ A |
| f _{APWM} | APWM output frequency | V _{AIN} =2.5V | 360 | 400 | 440 | kHz |
| BW _{AIN} | AIN-APWM bandwidth | | | 10 | | kHz |
| D _{APWM} | APWM Duty cycle | V _{AIN} = 0.5V | 85 | 90 | 95 | % |
| | | V _{AIN} = 2.5V | 45 | 50 | 55 | |
| | | V _{AIN} = 4.5V | 5 | 10 | 15 | |
| FLT AND RDY REPORTING | | | | | | |
| t _{RDYHLD} | VDD UVLO RDY low minimum holding time | | 0.55 | | 1 | ms |
| t _{FLTMUTE} | Output mute time on fault | Reset fault through $\overline{\text{RST/EN}}$ | 0.55 | | 1 | ms |
| R _{ODON} | Open drain output on resistance | I _{ODON} = 5mA | | 30 | | Ω |
| V _{ODL} | Open drain low output voltage | I _{ODON} = 5mA | | | 0.3 | V |
| COMMON MODE TRANSIENT IMMUNITY | | | | | | |
| CMTI | Common-mode transient immunity | | 150 | | | V/ns |

6.10 Switching Characteristics

VCC=5.0V, 1uF capacitor from VCC to GND, VDD–COM=20V, 18V or 15V, COM–VEE = 3V, 5V or 8V, C_L=100pF, –40°C<T_J<150°C (unless otherwise noted)

| PARAMETER | | TEST CONDITIONS | MIN | TYP | MAX | UNIT |
|--------------------|---|-------------------------------------|-----|-----|-----|------|
| t _{PDHL} | Propagation delay time – High to Low | | | 90 | | ns |
| t _{PDLH} | Propagation delay time – Low to High | | | 90 | | |
| PWD | Pulse width distortion t _{PDHL} – t _{PDLH} | | | | 25 | |
| t _{sk-pp} | Part to Part skew | Rising or Falling Propagation Delay | | | 30 | |
| t _r | Driver output rise time | C _L =10nF | | | 28 | |
| t _f | Driver output fall time | C _L =10nF | | | 24 | |
| f _{MAX} | Maximum switching frequency | | | | 1 | MHz |

6.11 Insulation Characteristics Curves

ADVANCE INFORMATION

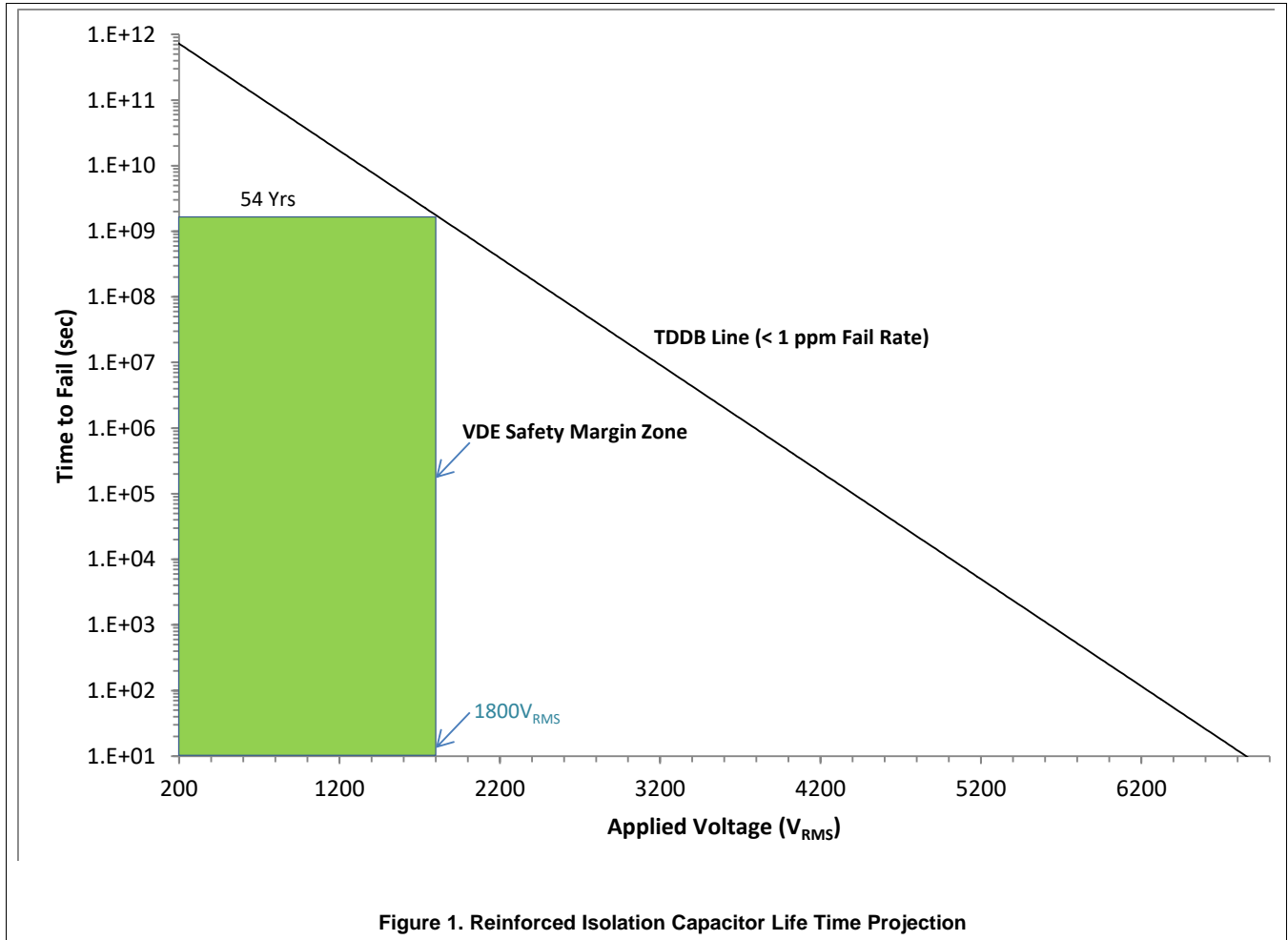

Figure 1. Reinforced Isolation Capacitor Life Time Projection

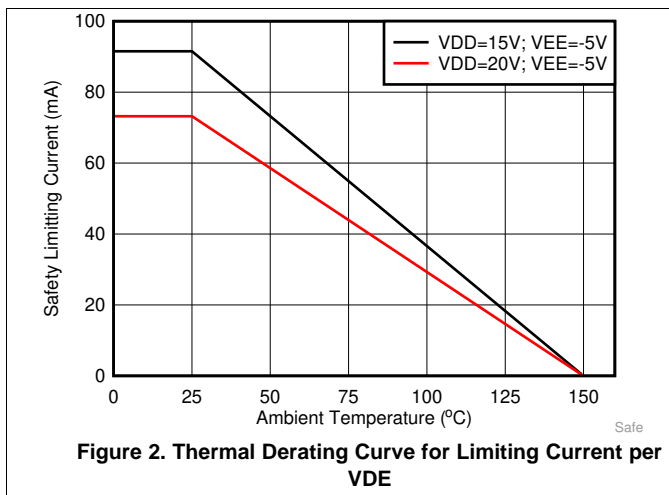

Figure 2. Thermal Derating Curve for Limiting Current per VDE

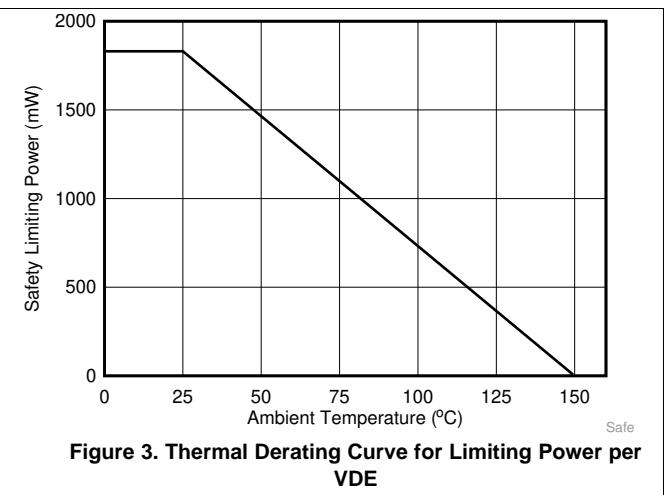
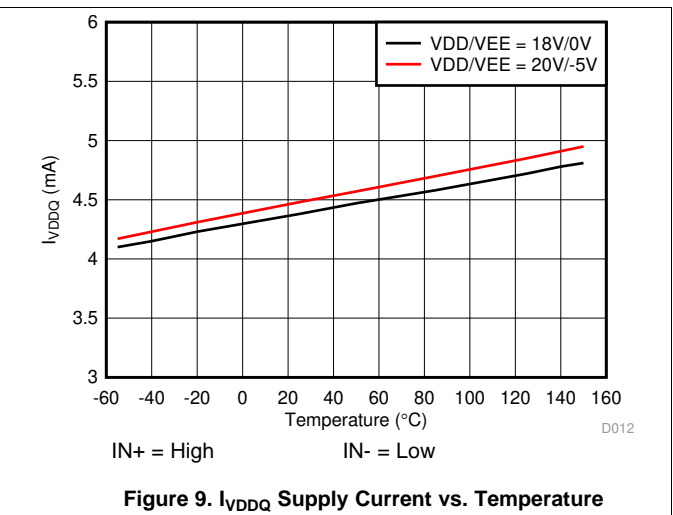
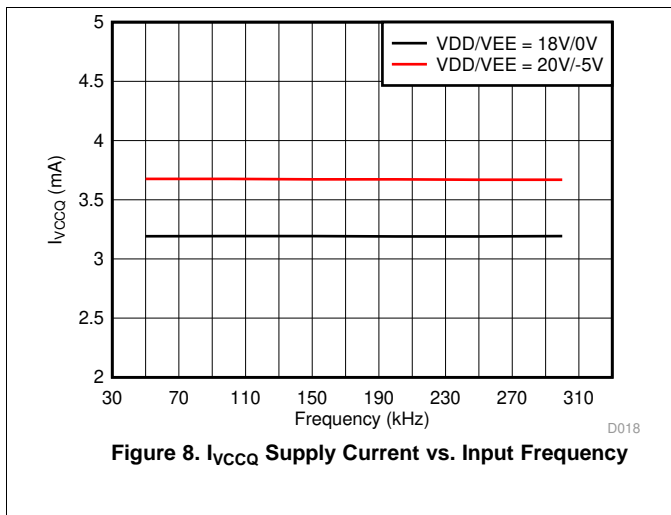
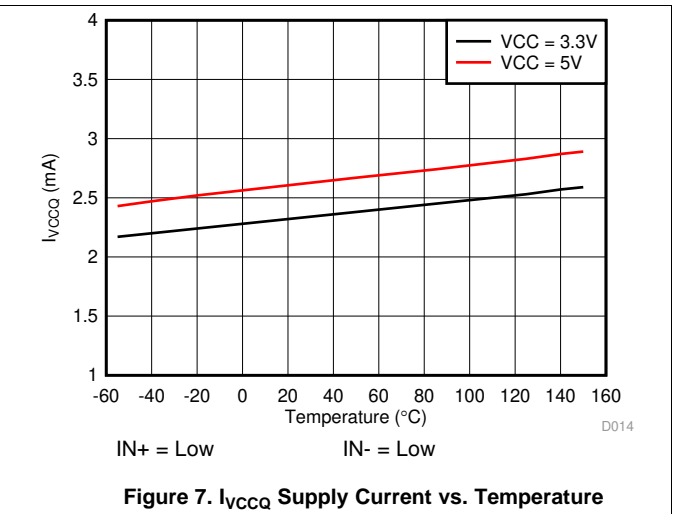
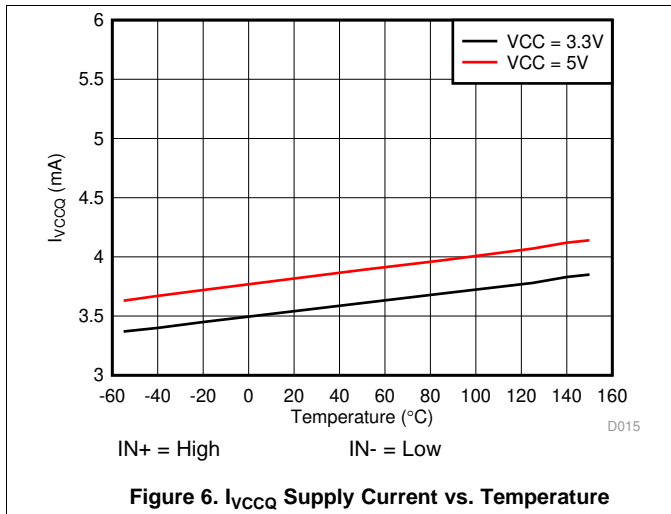
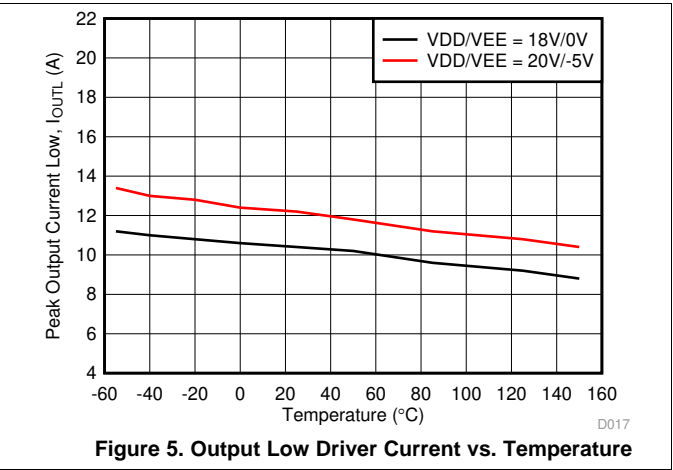
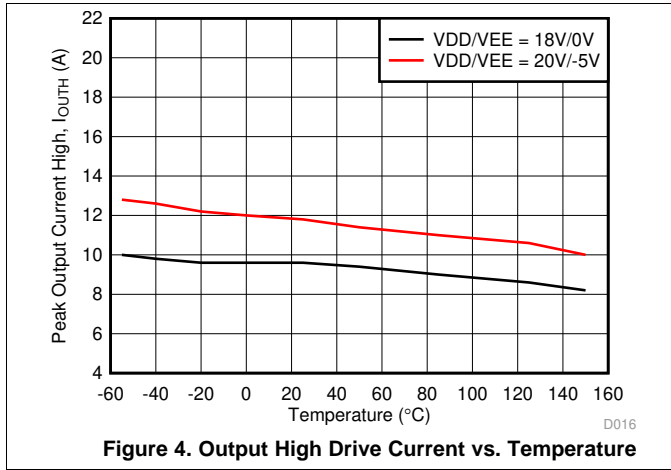

Figure 3. Thermal Derating Curve for Limiting Power per VDE

6.12 Typical Characteristics



ADVANCE INFORMATION

Typical Characteristics (continued)

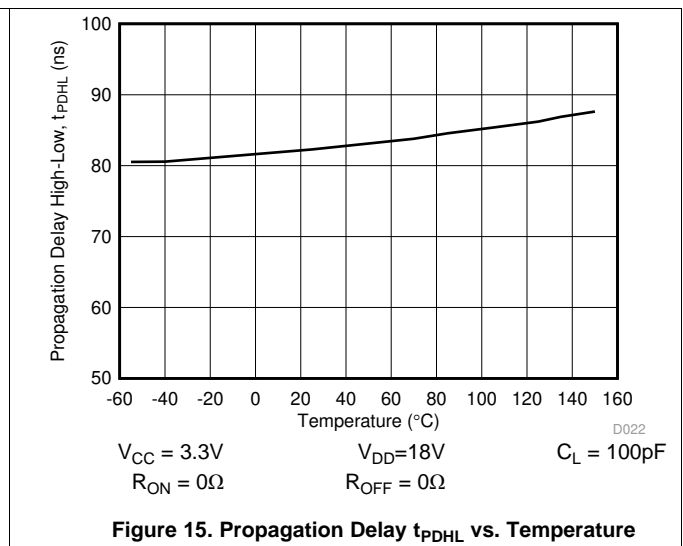
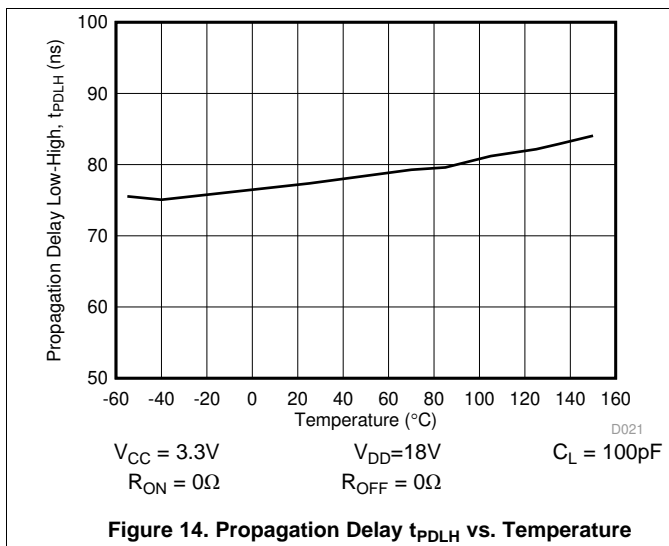
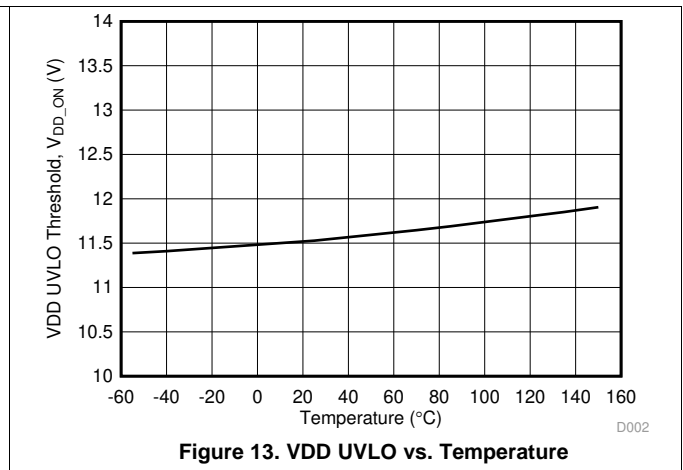
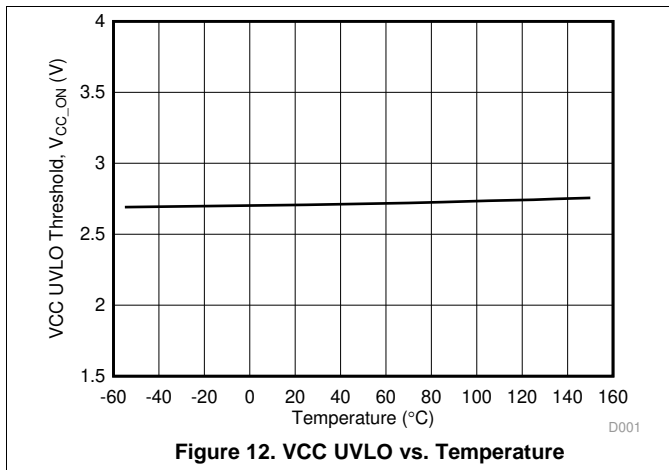
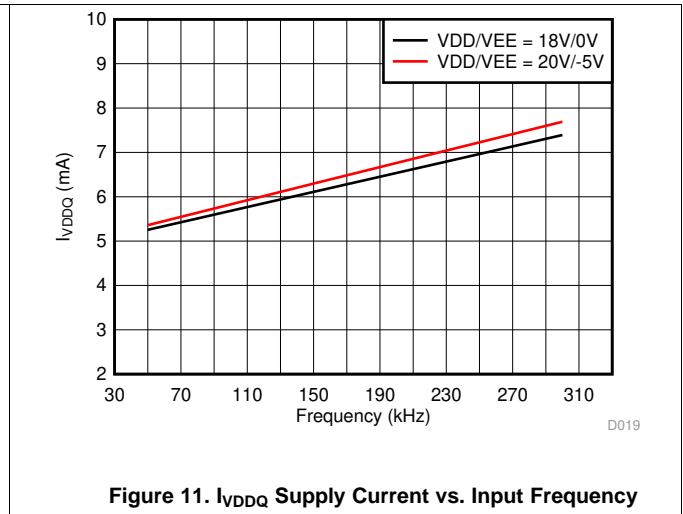
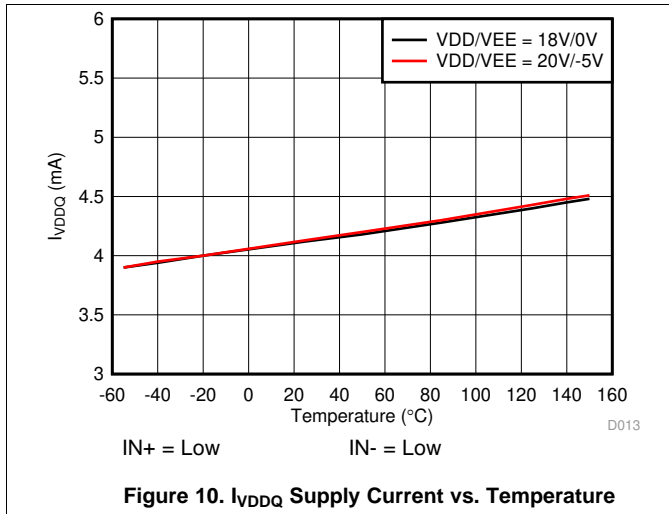

ADVANCE INFORMATION

Typical Characteristics (continued)

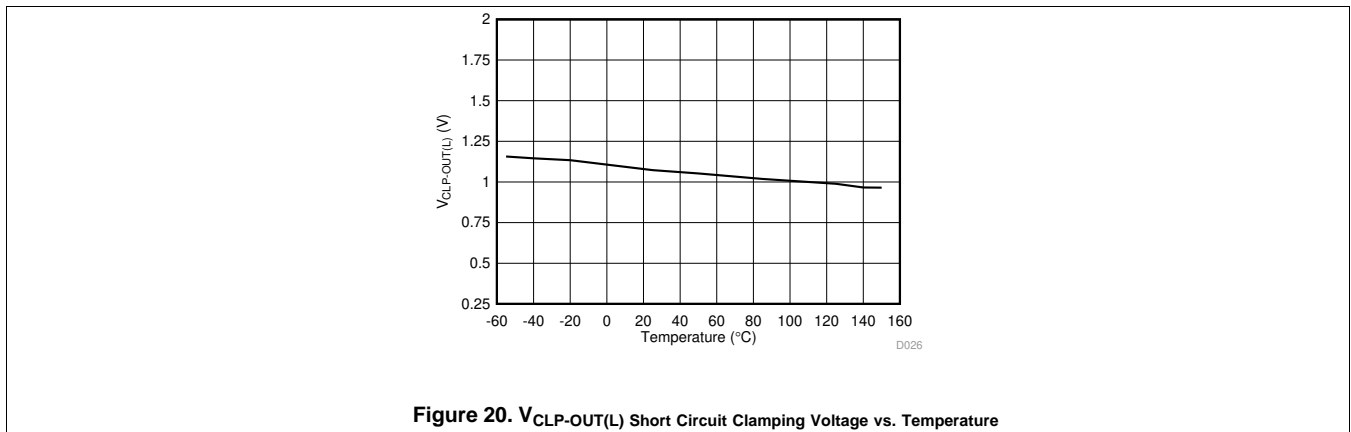
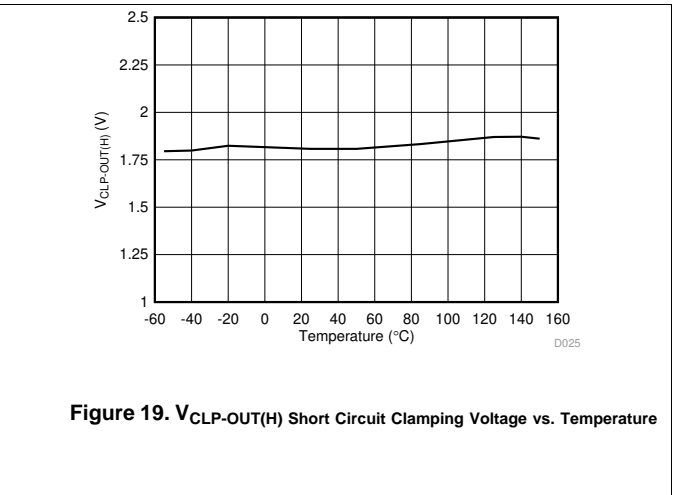
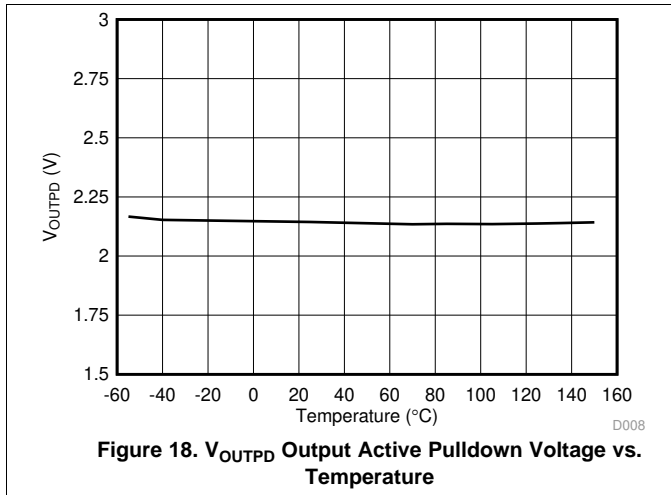
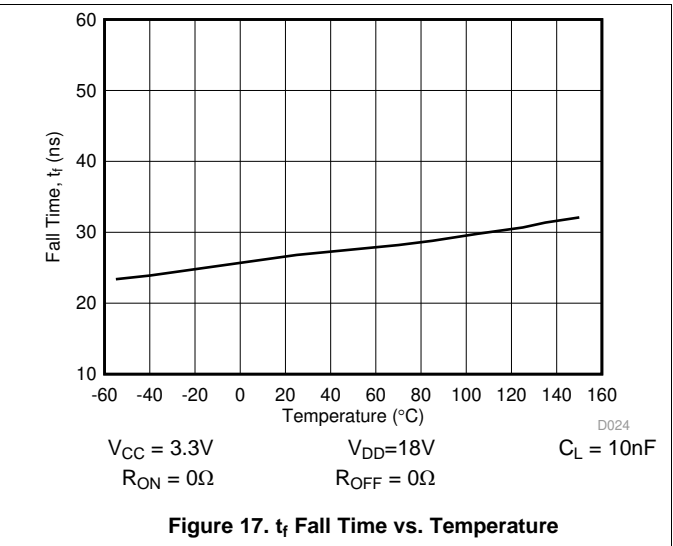
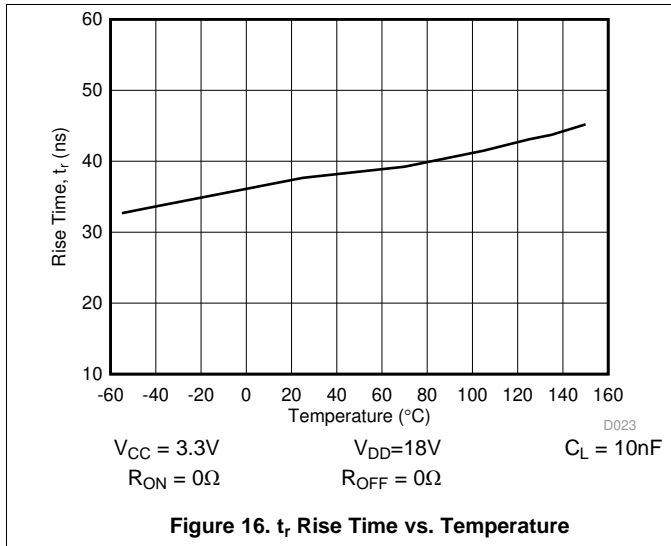

ADVANCE INFORMATION

7 Parameter Measurement Information

7.1 Propagation Delay

7.1.1 Regular Turn-OFF

Figure 21 shows the propagation delay measurement for non-inverting configurations. Figure 22 shows the propagation delay measurement with the inverting configurations.

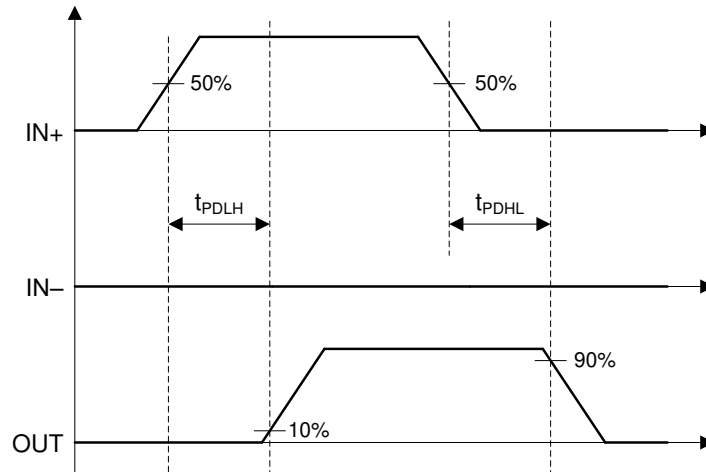

Figure 21. Non-inverting Logic Propagation Delay Measurement

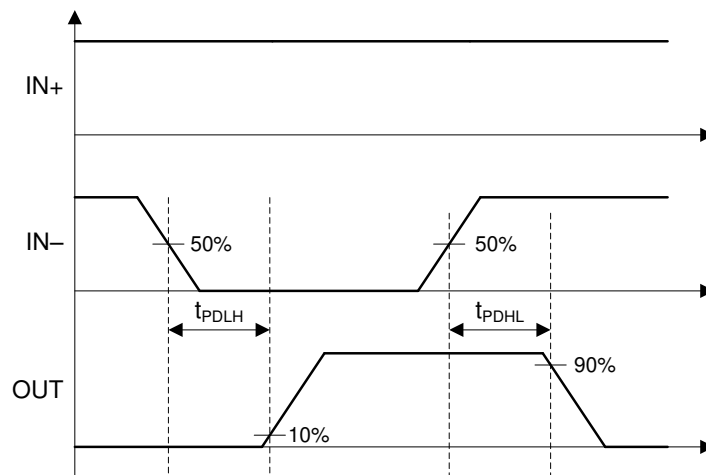

Figure 22. Inverting Logic Propagation Delay Measurement

7.2 Input Deglitch Filter

In order to increase the robustness of gate driver over noise transient and accidental small pulses on the input pins, i.e. IN+, IN-, RST/EN, a 40ns deglitch filter is designed to filter out the transients and make sure there is no faulty output responses or accidental driver malfunctions. When the IN+ or IN- PWM pulse is smaller than the input deglitch filter width, T_{INFIL} , there will be no responses on OUT drive signal. Figure 23 and Figure 24 shows the IN+ pin ON and OFF pulse deglitch filter effect. Figure 25 and Figure 26 shows the IN- pin ON and OFF pulse deglitch filter effect.

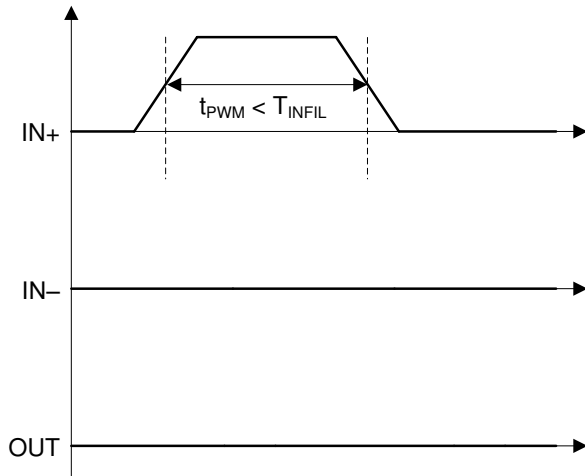

Figure 23. IN+ ON Deglitch Filter

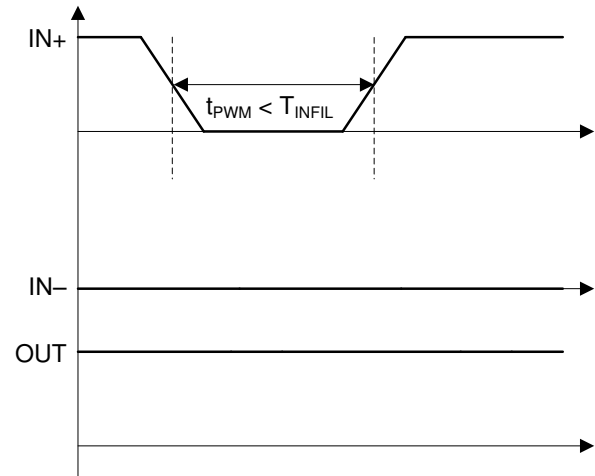

Figure 24. IN+ OFF Deglitch Filter

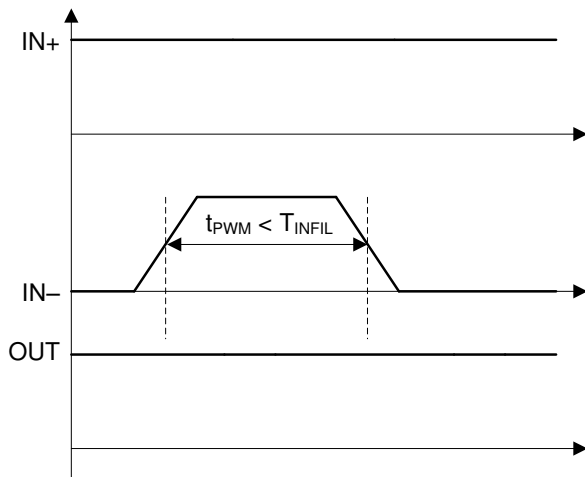

Figure 25. IN- ON Deglitch Filter

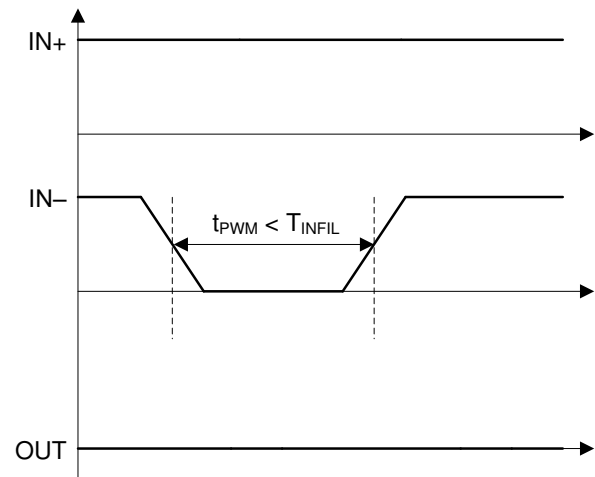

Figure 26. IN- OFF Deglitch Filter

ADVANCE INFORMATION

7.3 Active Miller Clamp

7.3.1 Internal On-chip Active Miller Clamp

For gate driver application with unipolar bias supply or bipolar supply with small negative turn-off voltage, active miller clamp can help add a additional low impedance path to bypass the miller current and prevent the high dV/dt introduced unintentional turn-on through the miller capacitance. Figure 27 shows the timing diagram for on-chip internal miller clamp function.

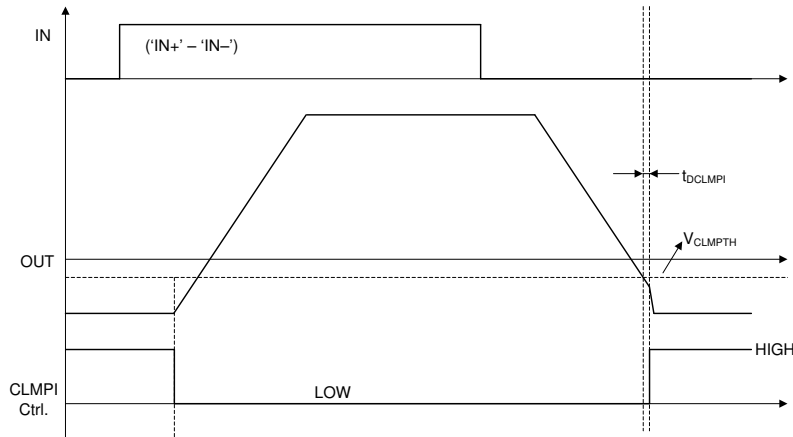

Figure 27. Timing Diagram for Internal Active Miller Clamp Function

7.4 Under Voltage Lockout (UVLO)

UVLO is one of the key protection features designed to protect the system in case of bias supply failures on VCC — primary side power supply, and VDD — secondary side power supply.

7.4.1 VCC UVLO

The VCC UVLO protection details are discussed in this section. Figure 28 shows the timing diagram illustrating the definition of UVLO ON/OFF threshold, deglitch filter, response time, RDY and AIN-APWM.

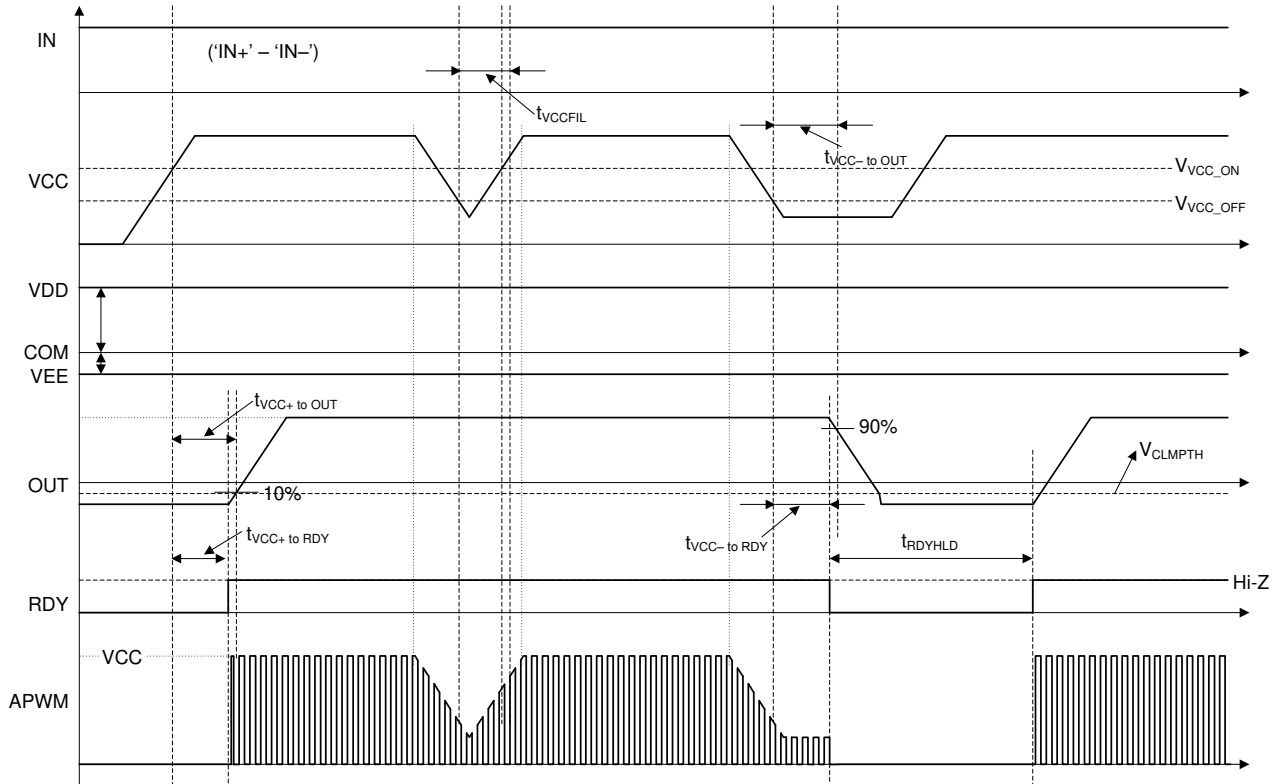

Figure 28. VCC UVLO Protection Timing Diagram

ADVANCE INFORMATION

Under Voltage Lockout (UVLO) (continued)

7.4.2 VDD UVLO

The VDD UVLO protection details are discussed in this section. Figure 29 shows the timing diagram illustrating the definition of UVLO ON/OFF threshold, deglitch filter, response time, RDY and AIN–APWM.

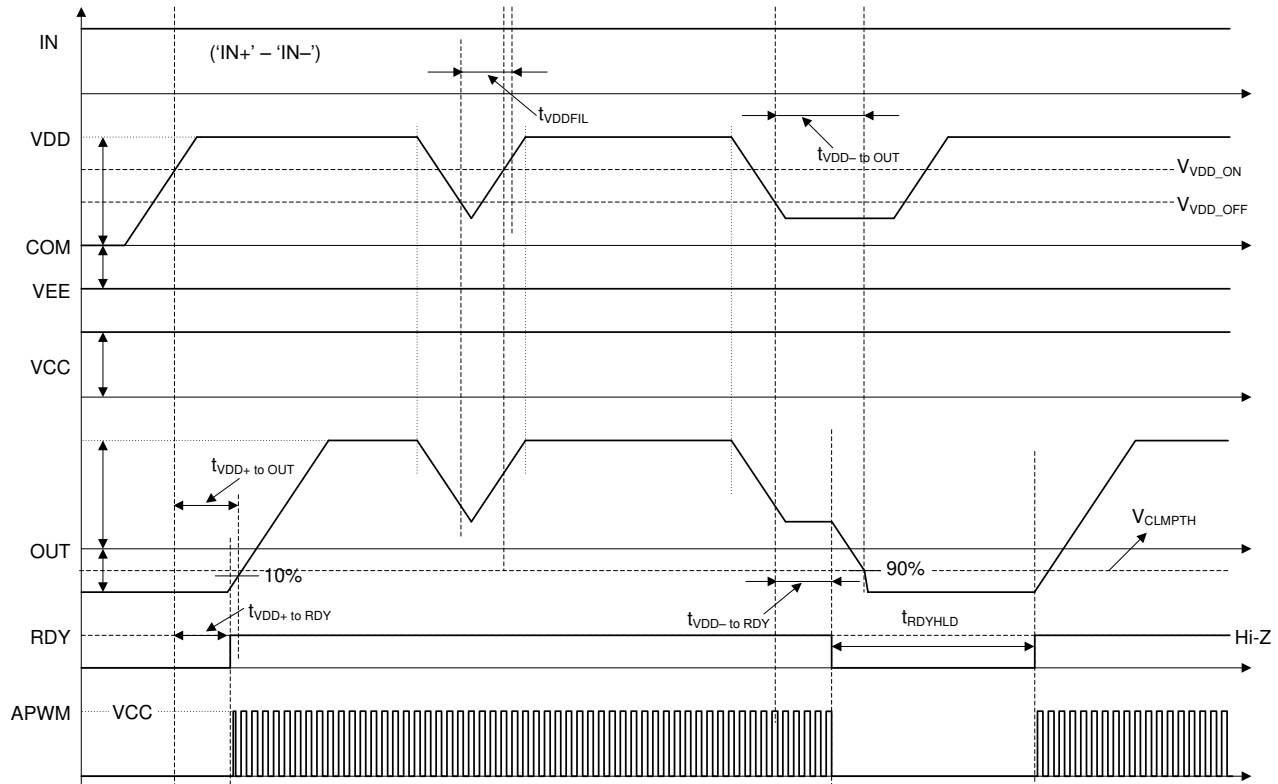

Figure 29. VDD UVLO Protection Timing Diagram

7.5 Desaturation (DESAT) Protection

7.5.1 DESAT Protection with Soft Turn-OFF

DESAT function is used to detect V_{DS} for SiC-MOSFETs or V_{CE} for IGBTs under over current conditions. Figure 30 shows the timing diagram of DESAT operation with soft turn-off during the turning on transition.

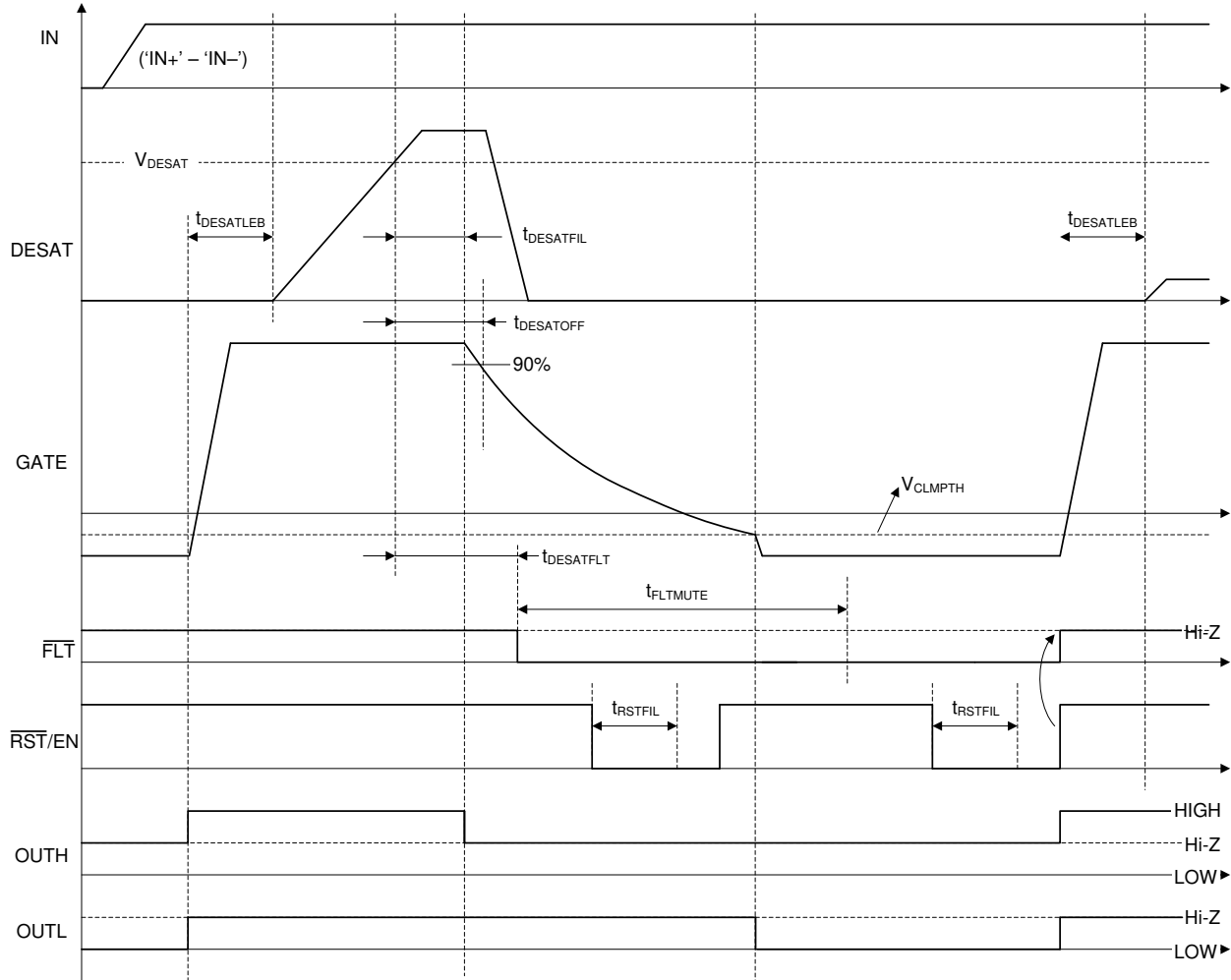

Figure 30. DESAT Protection with Soft Turn-OFF During Turn-on Transition

Desaturation (DESAT) Protection (continued)

Figure 31 shows the timing diagram of DESAT protection while the power device is already turned on.

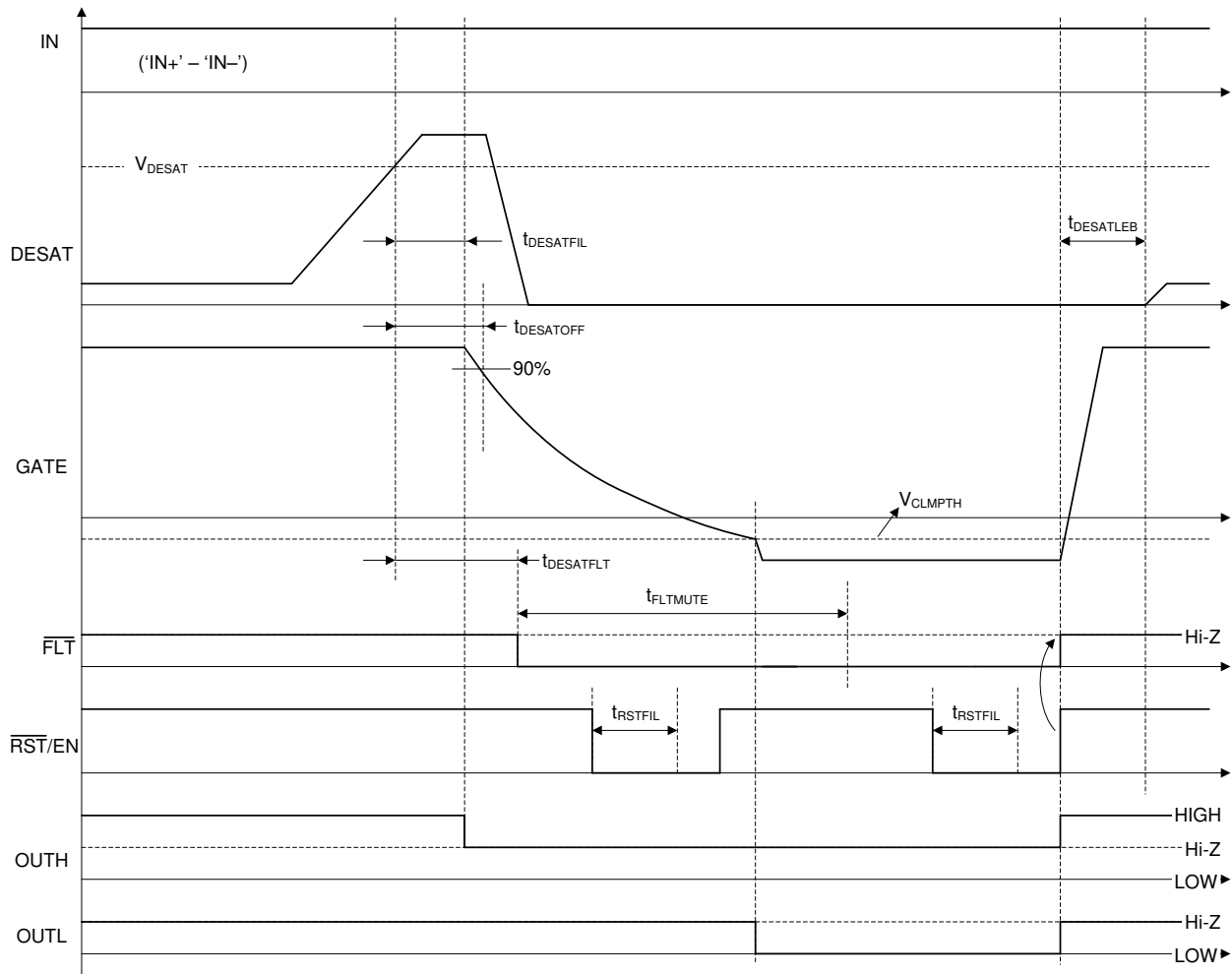

Figure 31. DESAT Protection with Soft Turn-OFF While Power Device is ON

ADVANCE INFORMATION

8 Detailed Description

8.1 Overview

The UCC21750-Q1 device is an advanced isolated gate driver with state-of-art protection and sensing features for SiC MOSFETs and IGBTs. The device can support up to 2121V DC operating voltage based on SiC MOSFETs and IGBTs, and can be used to above 10kW applications such as HEV/EV traction inverter, motor drive, on-board and off-board battery charger, solar inverter, etc. The galvanic isolation is implemented by the capacitive isolation technology, which can realize a reliable reinforced isolation between the low voltage DSP/MCU and high voltage side.

The $\pm 10\text{A}$ peak sink and source current of UCC21750-Q1 can drive the SiC MOSFET modules and IGBT modules directly without an extra buffer. The driver can also be used to drive higher power modules or parallel modules with external buffer stage. The input side is isolated with the output side with a reinforced isolation barrier based on capacitive isolation technology. The device can support up to 1.5-kV_{RMS} working voltage, 12.8-kV_{PK} surge immunity with longer than 40 years isolation barrier life. The strong drive strength helps to switch the device fast and reduce the switching loss. While the 150V/ns minimum CMTI guarantees the reliability of the system with fast switching speed. The small propagation delay and part-to-part skew can minimize the deadtime setting, so the conduction loss can be reduced.

The device includes extensive protection and monitor features to increase the reliability and robustness of the SiC MOSFET and IGBT based systems. The 12V output side power supply UVLO is suitable for switches with gate voltage $\geq 15\text{V}$. The active miller clamp feature prevents the false turn on causing by miller capacitance during fast switching. The device has the state-of-art DESAT detection time, and fault reporting function to the low voltage side DSP/MCU. The soft turn off is triggered when the DESAT fault is detected, minimizing the short circuit energy while reducing the overshoot voltage on the switches.

The isolated analog to PWM sensor can be used as switch temperature sensing, DC bus voltage sensing, auxiliary power supply sensing, etc. The PWM signal can be fed directly to DSP/MCU or through a low-pass-filter as an analog signal.

8.2 Functional Block Diagram

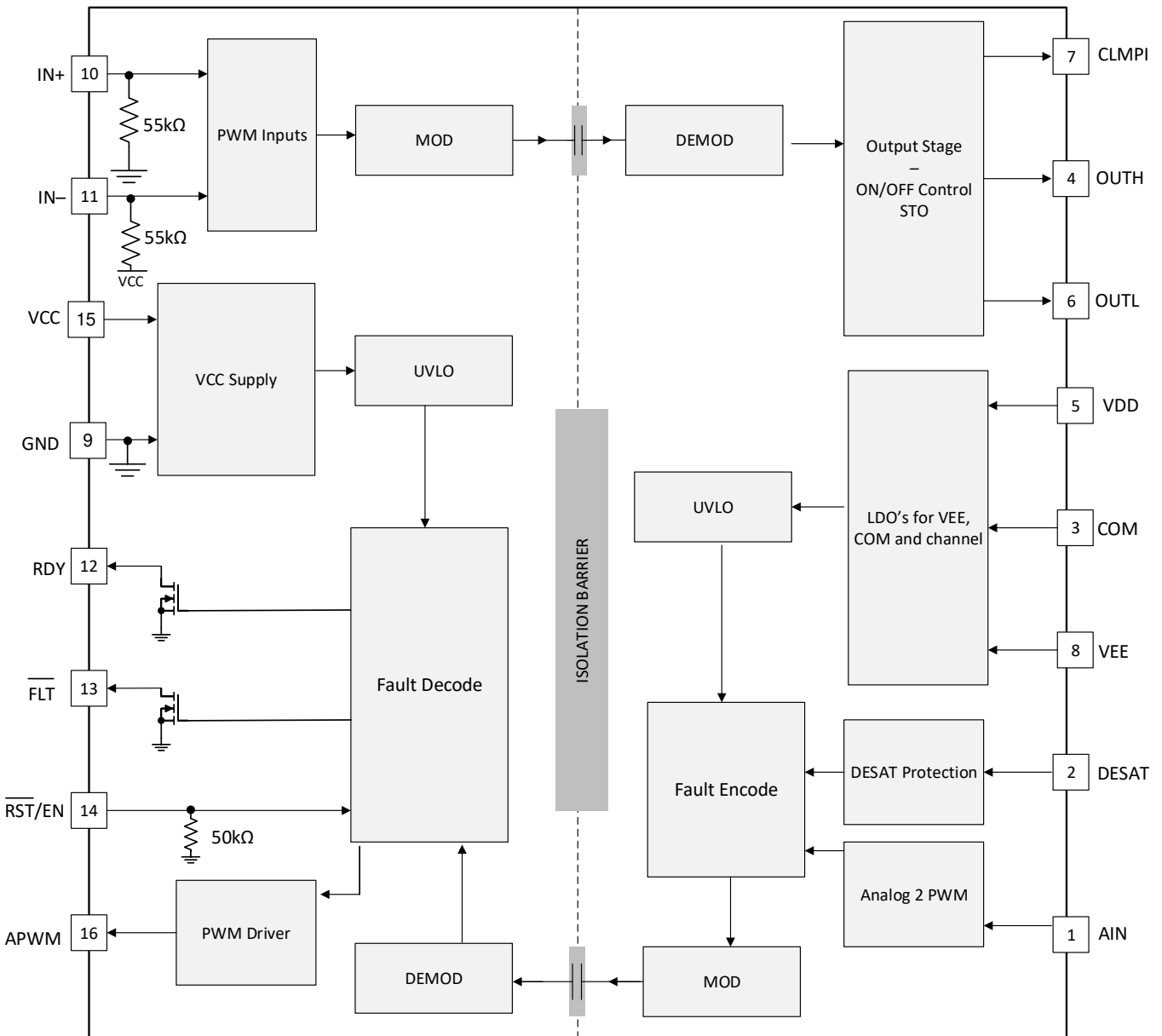

ADVANCE INFORMATION

8.3 Feature Description

8.3.1 Power Supply

The input side power supply VCC can support a wide voltage range from 3V to 5.5V. The device supports both unipolar and bipolar power supply on the output side, with a wide range from 13V to 33V from VDD to VEE. The negative power supply with respect to switch source or emitter is usually adopted to avoid false turn on when the other switch in the phase leg is turned on. The negative voltage is especially important for SiC MOSFET due to its fast switching speed.

Feature Description (continued)

8.3.2 Driver Stage

UCC21750-Q1 has $\pm 10A$ peak drive strength and is suitable for high power applications. The high drive strength can drive a SiC MOSFET module, IGBT module or paralleled discrete devices directly without extra buffer stage. UCC21750-Q1 can also be used to drive higher power modules or parallel modules with extra buffer stage. Regardless of the values of VDD, the peak sink and source current can be kept at 10A. The driver features an important safety function wherein, when the input pins are in floating condition, the OUTH/OUTL is held in LOW state. The split output of the driver stage is depicted in . The driver has rail-to-rail output by implementing a hybrid pull-up structure with a P-Channel MOSFET in parallel with an N-Channel MOSFET, and an N-Channel MOSFET to pulldown. The pull-up NMOS is the same as the pull down NMOS, so the on resistance R_{NMOS} is the same as R_{OL} . The hybrid pull-up structure delivers the highest peak-source current when it is most needed, during the miller plateau region of the power semiconductor turn-on transient. The R_{OH} in represents the on-resistance of the pull-up P-Channel MOSFET. However, the effective pull-up resistance is much smaller than R_{OH} . Since the pull-up N-Channel MOSFET has much smaller on-resistance than the P-Channel MOSFET, the pull-up N-Channel MOSFET dominates most of the turn-on transient, until the voltage on OUTH pin is about 3V below VDD voltage. The effective resistance of the hybrid pull-up structure during this period is about $2 \times R_{OL}$. Then the P-Channel MOSFET pulls up the OUTH voltage to VDD rail. The low pull-up impedance results in strong drive strength during the turn-on transient, which shortens the charging time of the input capacitance of the power semiconductor and reduces the turn on switching loss.

The pull-down structure of the driver stage is implemented solely by a pull-down N-Channel MOSFET. The on-resistance of the N-Channel MOSFET R_{OL} can be found in the . This MOSFET can ensure the OUTL voltage be pulled down to VEE rail. The low pull-down impedance not only results in high sink current to reduce the turn-off time, but also helps to increase the noise immunity considering the miller effect.

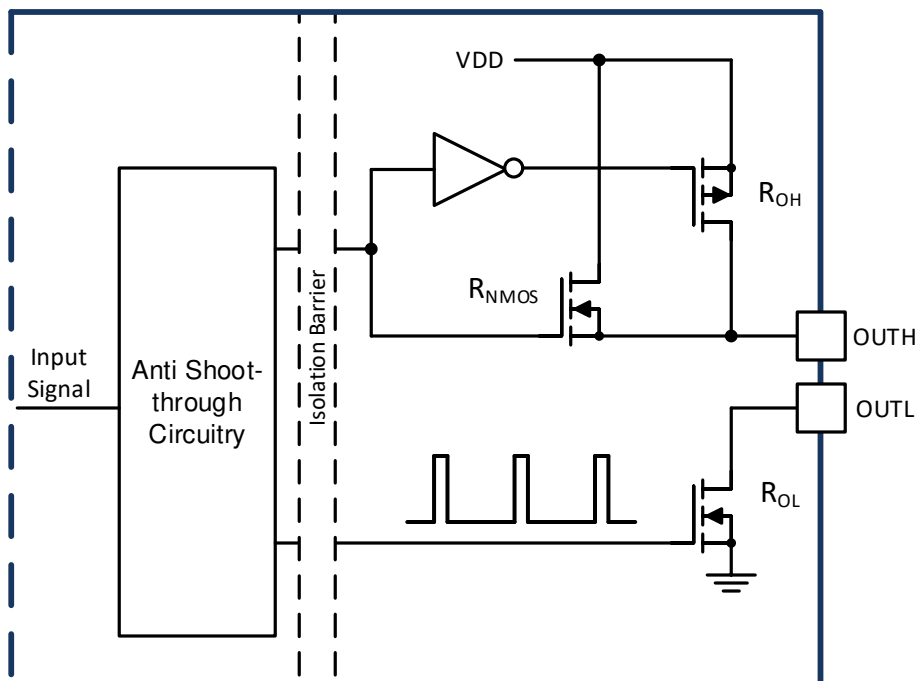

Figure 32. Gate Driver Output Stage

Feature Description (continued)

8.3.3 VCC and VDD Undervoltage Lockout (UVLO)

UCC21750-Q1 implements the internal UVLO protection feature for both input and output power supplies VCC and VDD. When the supply voltage is lower than the threshold voltage, the driver output is held as LOW. The output only goes HIGH when both VCC and VDD are out of the UVLO status. The UVLO protection feature not only reduces the power consumption of the driver itself during low power supply voltage condition, but also increases the efficiency of the power stage. For SiC MOSFET and IGBT, the on-resistance reduces while the gate-source voltage or gate-emitter voltage increases. If the power semiconductor is turned on with a low VDD value, the conduction loss increases significantly and can lead to a thermal issue and efficiency reduction of the power stage. UCC21750-Q1 implements 12V threshold voltage of VDD UVLO, with 800mV hysteresis. This threshold voltage is suitable for both SiC MOSFET and IGBT.

The UVLO protection block features with hysteresis and deglitch filter, which help to improve the noise immunity of the power supply. During the turn on and turn off switching transient, the driver sources and sinks a peak transient current from the power supply, which can result in sudden voltage drop of the power supply. With hysteresis and UVLO deglitch filter, the internal UVLO protection block will ignore small noises during the normal switching transients.

The timing diagrams of the UVLO feature of VCC and VDD are shown in [Figure 28](#), and [Figure 29](#). The RDY pin on the input side is used to indicate the power good condition. The RDY pin is open drain. During UVLO condition, the RDY pin is held in low status and connected to GND. Normally the pin is pulled up externally to VCC to indicate the power good. The AIN-APWM function stops working during the UVLO status. The APWM pin on the input side will be held LOW.

8.3.4 Active Pulldown

UCC21750-Q1 implements an active pulldown feature to ensure the OUTH/OUTL pin clamping to VEE when the VDD is open. The OUTH/OUTL pin is in high-impedance status when VDD is open, the active pulldown feature can prevent the output be false turned on before the device is back to control.

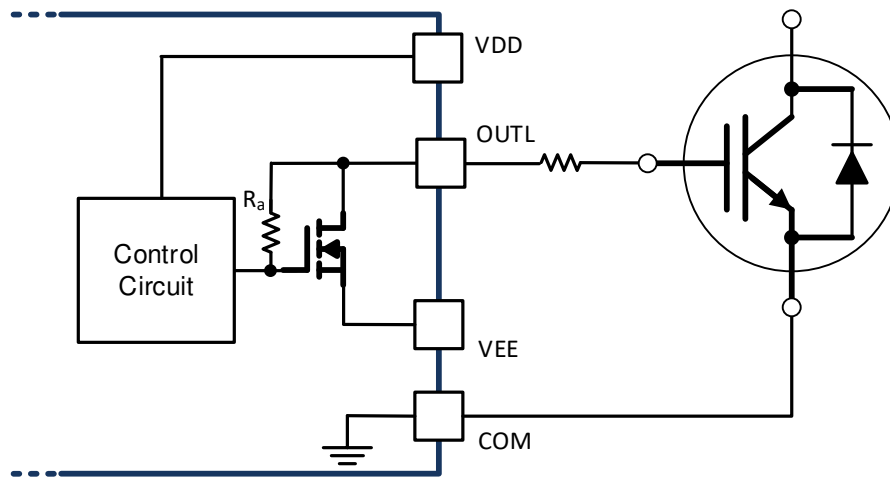

Figure 33. Active Pulldown

8.3.5 Short Circuit Clamping

During short circuit condition, the miller capacitance can cause a current sinking to the OUTH/OUTL/CLMPI pin due to the high dV/dt and boost the OUTH/OUTL/CLMPI voltage. The short circuit clamping feature of UCC21750-Q1 can clamp the OUTH/OUTL/CLMPI pin voltage to be slightly higher than VDD, which can protect the power semiconductors from a gate-source and gate-emitter overvoltage breakdown. This feature is realized by an internal diode from the OUTH/OUTL/CLMPI to VDD.

Feature Description (continued)

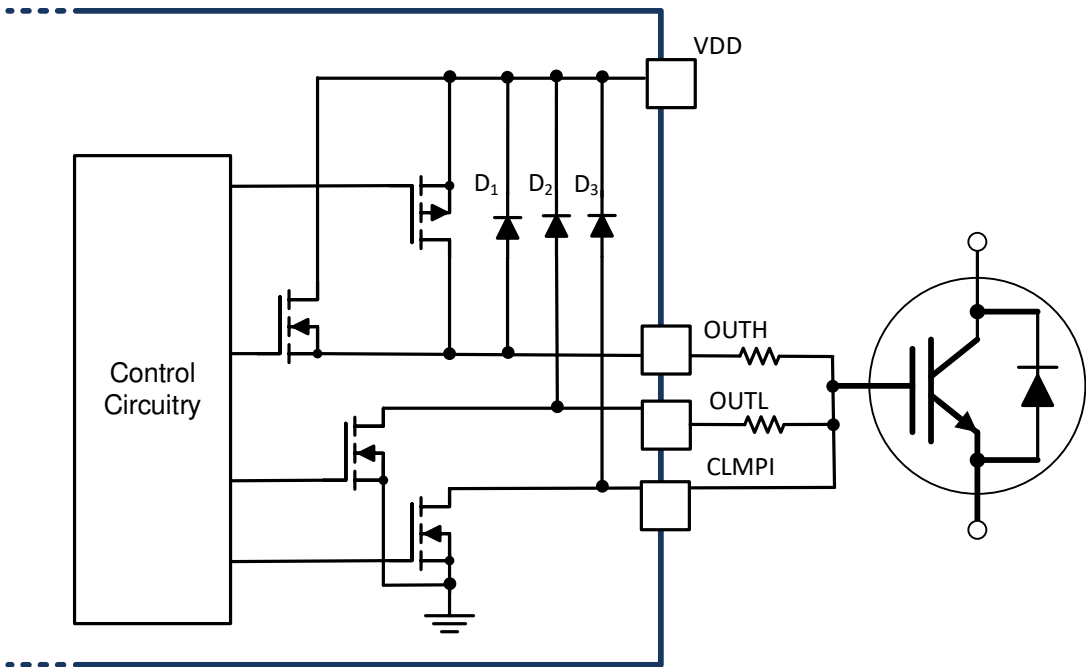

Figure 34. Short Circuit Clamping

8.3.6 Internal Active Miller Clamp

Active miller clamp feature is important to prevent the false turn-on while the driver is in OFF state. In applications which the device can be in synchronous rectifier mode, the body diode conducts the current during the deadtime while the device is in OFF state, the drain-source or collector-emitter voltage remains the same and the dV/dt happens when the other power semiconductor of the phase leg turns on. The low internal pull-down impedance of UCC21750-Q1 can provide a strong pulldown to hold the OUTL to VEE. However, external gate resistance is usually adopted to limit the dV/dt . The miller effect during the turn on transient of the other power semiconductor can cause a voltage drop on the external gate resistor, which boost the gate-source or gate-emitter voltage. If the voltage on V_{GS} or V_{GE} is higher than the threshold voltage of the power semiconductor, a shoot through can happen and cause catastrophic damage. The active miller clamp feature of UCC21750-Q1 drives an internal MOSFET, which connects to the device gate. The MOSFET is triggered when the gate voltage is lower than V_{CLMPH} , which is 2V above VEE, and creates a low impedance path to avoid the false turn on issue.

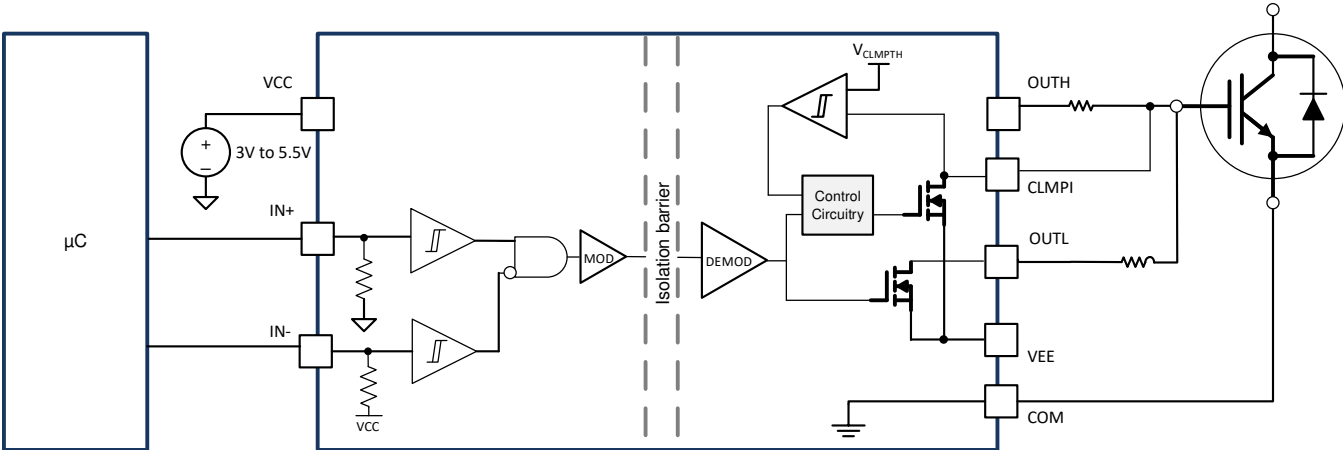

Figure 35. Active Miller Clamp

ADVANCE INFORMATION

Feature Description (continued)

8.3.7 Overcurrent and Short Circuit Protection

The UCC21750-Q1 implements a fast overcurrent and short circuit protection feature to protect the IGBT module from catastrophic breakdown during fault. The DESAT pin of the device has a typical 9V threshold with respect to COM, source or emitter of the power semiconductor. When the input is in floating condition, or the output is held in low state, the DESAT pin is pulled down by an internal MOSFET and held in LOW state, which prevents the overcurrent and short circuit fault from false triggering. The internal current source of the DESAT pin is activated only during the driver ON state, which means the overcurrent and short circuit protection feature only works when the power semiconductor is in on state. The internal pulldown MOSFET helps to discharge the voltage of DESAT pin when the power semiconductor is turned off. UCC21750-Q1 features a 200ns internal leading edge blanking time after the OUTH switches to high state. The internal current source is activated to charge the external blanking capacitor after the internal leading edge blanking time. The typical value of the internal current source is 500µA.

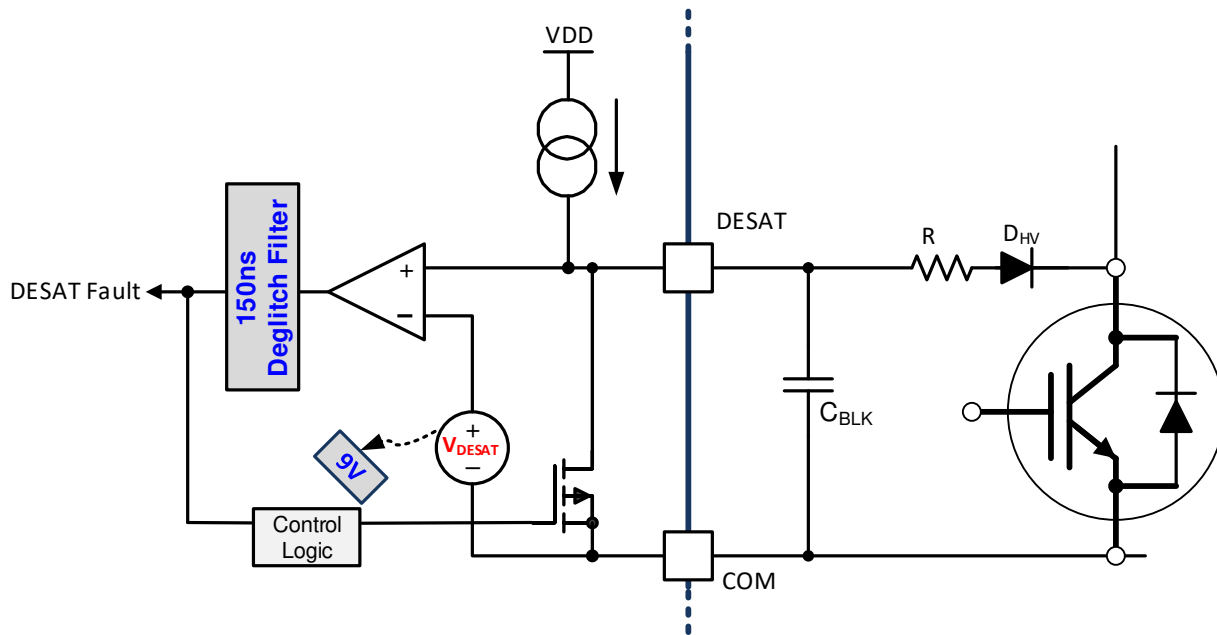

Figure 36. Overcurrent and Short Circuit Protection

8.3.8 Soft Turn-off

UCC21750-Q1 initiates a soft turn-off when the overcurrent and short circuit protection is triggered. When the overcurrent and short circuit fault happens, the IGBT transits from the active region to the desaturation region very fast. The channel current is controlled by the gate voltage and decreasing in a soft manner, thus the overshoot of the IGBT is limited and prevents the overvoltage breakdown. There is a tradeoff between the overshoot voltage and short circuit energy. The turn off speed needs to be slow to limit the overshoot voltage, but the shutdown time should not be too long that the large energy dissipation can breakdown the device. The 400mA soft turn off current of UCC21750-Q1 makes sure the power switches is safely turned off during short circuit events. The timing diagram of soft turn-off shows in [Figure 30](#).

ADVANCE INFORMATION

Feature Description (continued)

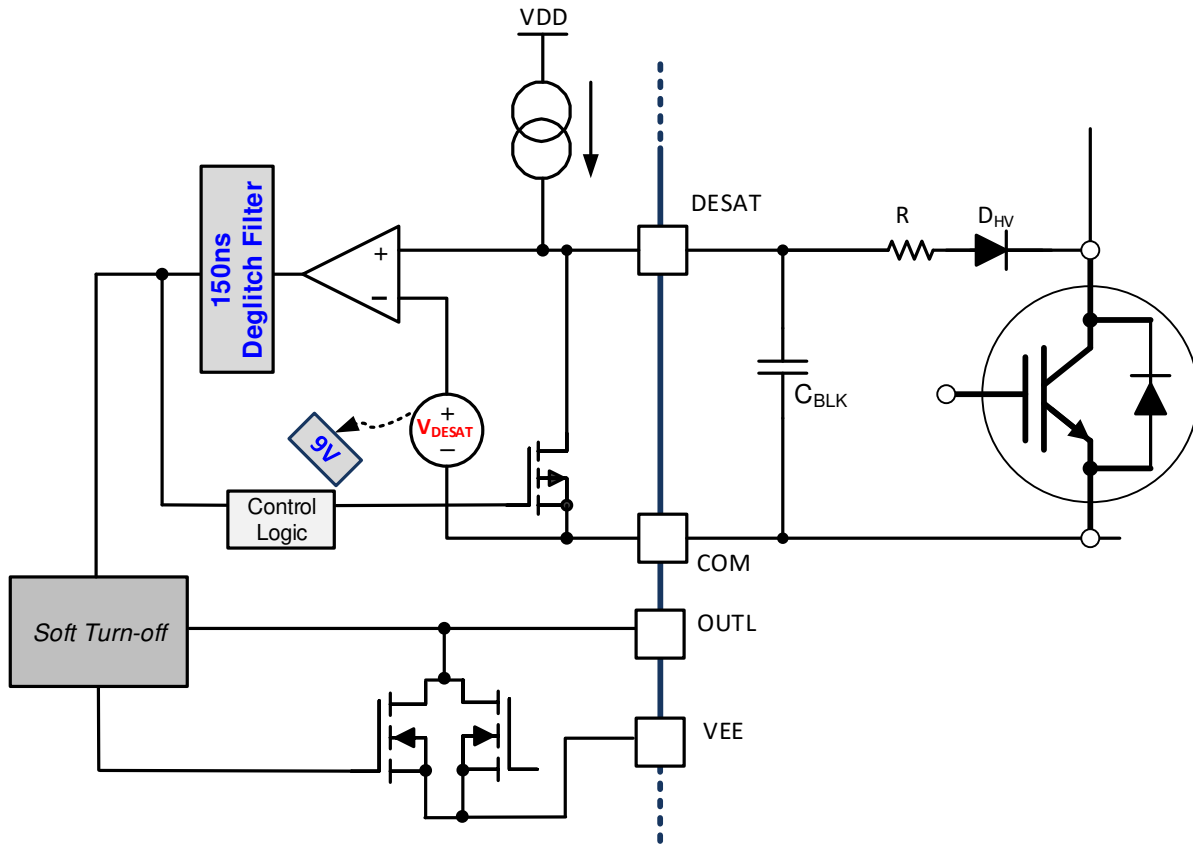

Figure 37. 2-Level Turn-off

8.3.9 Fault ($\overline{\text{FLT}}$, Reset and Enable ($\overline{\text{RST/EN}}$)

The $\overline{\text{FLT}}$ pin of UCC21750-Q1 is open drain and can report a fault signal to the DSP/MCU when the overcurrent and short circuit fault is detected through DESAT pin. The $\overline{\text{FLT}}$ pin is pulled down to GND, and is held in low state unless a reset signal is received from RST/EN. The device has a fault mute time t_{FLTMUTE} , within which the device ignores any reset signal.

The $\overline{\text{RST/EN}}$ is pulled down internally. The device is disabled by default if the $\overline{\text{RST/EN}}$ pin is floating. The pin has two purposes:

- Resets the overcurrent and short circuit fault signaled on $\overline{\text{FLT}}$ pin. The $\overline{\text{RST/EN}}$ pin is active low, if the pin is set and held in low state for more than t_{RSTFIL} , the fault signal is reset and $\overline{\text{FLT}}$ is reset back to the high impedance status at the rising edge of $\overline{\text{RST/EN}}$ pin.
- Enable and shutdown the device. If the $\overline{\text{RST/EN}}$ pin is pulled low, the driver is disabled and shut down by the regular turn off. The pin must be pulled up externally to enable the part, otherwise the device is disabled by default.

8.3.10 Isolated Analog to PWM Signal Function

The UCC21750-Q1 features an isolated analog to PWM signal function from AIN to APWM pin, which allows the isolated temperature sensing, high voltage dc bus voltage sensing, etc. An internal current source I_{AIN} in AIN pin is implemented in the device to bias an external thermal diode or temperature sensing resistor. The UCC21750-Q1 encodes the voltage signal V_{AIN} to a PWM signal, passing through the reinforced isolation barrier, and output to APWM pin on the input side. The PWM signal can either be transferred directly to DSP/MCU to calculate the duty cycle, or filtered by a simple RC filter as an analog signal. The AIN voltage input range is from 0.6V to 4.5V, and the corresponding duty cycle of the APWM output ranges from 88% to 10%. The duty cycle increases

Feature Description (continued)

linearly from 10% to 88% while the AIN voltage decreases from 4.5V to 0.6V. This corresponds to the temperature coefficient of the negative temperature coefficient (NTC) resistor and thermal diode. When AIN is floating, the AIN voltage is 5V and the APWM operates at 400kHz with approximately 10% duty cycle. The accuracy of the duty cycle is $\pm 5\%$ across temperature without one time calibration. The accuracy can be improved to $\pm 2\%$ with calibration. The accuracy of the internal current source I_{AIN} is 3% across temperature.

The isolated analog to PWM signal feature can also support other analog signal sensing, such as the high voltage dc bus voltage, etc. The internal current source I_{AIN} should be taken into account when designing the potential divider if sensing a high voltage.

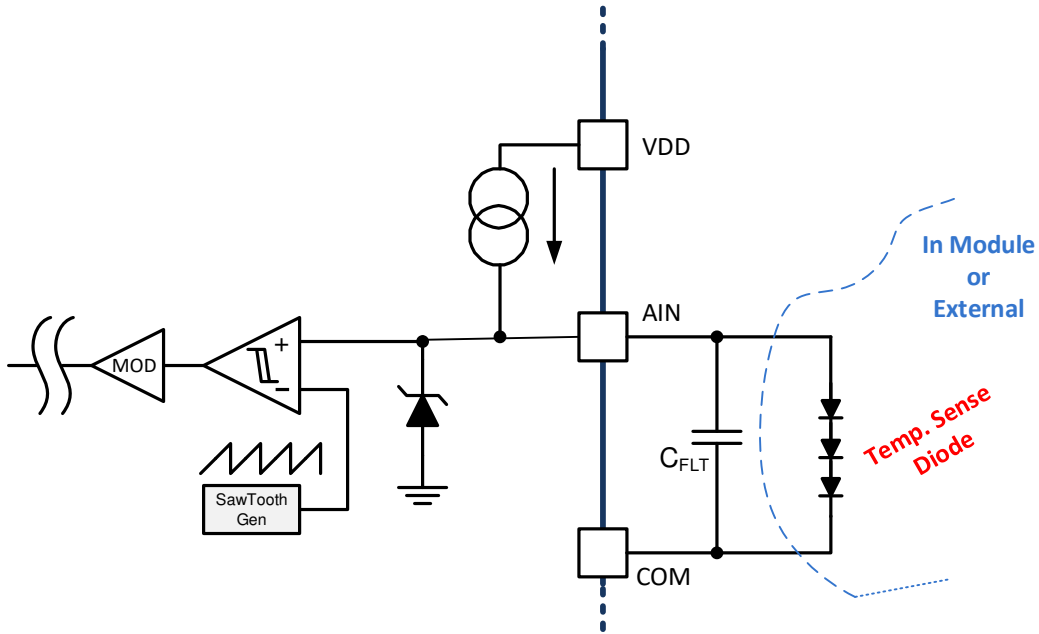

Figure 38. Isolated Analog to PWM Signal

8.4 Device Functional Modes

lists the device function.

Table 1. Function Table

| Input | | | | | | | Output | | | | |
|-------|------|------|------|------|-----------------------------------|-----|--------|-------------------------|---------------|-------|------|
| VCC | VDD | VEE | IN+ | IN- | $\overline{\text{RST}}/\text{EN}$ | AIN | RDY | $\overline{\text{FLT}}$ | OUTH/ OUTL | CLMPI | APWM |
| PU | PD | PU | X | X | X | X | Low | HiZ | Low | Low | Low |
| PD | PU | PU | X | X | X | X | HiZ | HiZ | Low | Low | Low |
| PU | PU | PU | X | X | Low | X | HiZ | HiZ | Low | Low | Low |
| PU | Open | PU | X | X | X | X | Low | HiZ | HiZ | HiZ | HiZ |
| PU | PU | Open | X | X | X | X | Low | HiZ | Low | Low | Low |
| PU | PU | PU | Low | X | High | X | HiZ | HiZ | Low | Low | P* |
| PU | PU | PU | X | High | High | X | HiZ | HiZ | Low | Low | P* |
| PU | PU | PU | High | High | High | X | HiZ | HiZ | Low | Low | P* |

PU: Power Up ($V_{CC} \geq 2.85V$, $V_{DD} \geq 13.1V$, $V_{EE} \leq 0V$); PD: Power Down ($V_{CC} \leq 2.35V$, $V_{DD} \leq 9.9V$); X: Irrelevant; P*: PWM Pulse; HiZ: High Impedance

9 Applications and Implementation

NOTE

Information in the following applications sections is not part of the TI component specification, and TI does not warrant its accuracy or completeness. TI's customers are responsible for determining suitability of components for their purposes. Customers should validate and test their design implementation to confirm system functionality.

9.1 Application Information

The UCC21750-Q1 device is very versatile because of the strong drive strength, wide range of output power supply, high isolation ratings, high CMTI and superior protection and sensing features. The 1.5-kVRMS working voltage and 12.8-kV_{PK} surge immunity can support up both SiC MOSFET and IGBT modules with DC bus voltage up to 2121V. The device can be used in both low power and high power applications such as the traction inverter in HEV/EV, on-board charger and charging pile, motor driver, solar inverter, industrial power supplies and etc. The device can drive the high power SiC MOSFET module, IGBT module or paralleled discrete device directly without external buffer drive circuit based on NPN/PNP bipolar transistor in totem-pole structure, which allows the driver to have more control to the power semiconductor and saves the cost and space of the board design. UCC21750-Q1 can also be used to drive very high power modules or paralleled modules with external buffer stage. The input side can support power supply and microcontroller signal from 3.3V to 5V, and the device level shifts the signal to output side through reinforced isolation barrier. The device has wide output power supply range from 13V to 33V and support wide range of negative power supply. This allows the driver to be used in SiC MOSFET applications, IGBT application and many others. The 12V UVLO benefits the power semiconductor with lower conduction loss and improves the system efficiency. As a reinforced isolated single channel driver, the device can be used to drive either a low-side or high-side driver.

UCC21750-Q1 device features extensive protection and monitoring features, which can monitor, report and protect the system from various fault conditions.

- Fast detection and protection for the overcurrent and short circuit fault. The semiconductor is shutdown when the fault is detected and FLTb pin is pulled down to indicate the fault detection. The device is latched unless reset signal is received from the RST/EN pin.
- Soft turn-off feature to protect the power semiconductor from catastrophic breakdown during overcurrent and short circuit fault. The shutdown energy can be controlled while the overshoot of the power semiconductor is limited.
- UVLO detection to protect the semiconductor from excessive conduction loss. Once the device is detected to be in UVLO mode, the output is pulled down and RDY pin indicates the power supply is lost. The device is back to normal operation mode once the power supply is out of the UVLO status. The power good status can be monitored from the RDY pin.
- Analog signal sensing with isolated analog to PWM signal feature. This feature allows the device to sense the temperature of the semiconductor from the thermal diode or temperature sensing resistor, or dc bus voltage with resistor divider. A PWM signal is generated on the low voltage side with reinforced isolated from the high voltage side. The signal can be fed back to the microcontroller for the temperature monitoring, voltage monitoring and etc.
- The active miller clamp feature protects the power semiconductor from false turn on.
- Enable and disable function through the RSTb/EN pin.
- Short circuit clamping.
- Active pulldown.

9.2 Typical Application

shows the typical application of a half bridge using two UCC21750-Q1 isolated gate drivers. The half bridge is a basic element in various power electronics applications such as traction inverter in HEV/EV to convert the DC current of the electric vehicle's battery to the AC current to drive the electric motor in the propulsion system. The topology can also be used in motor drive applications to control the operating speed and torque of the AC motors.

Typical Application (continued)

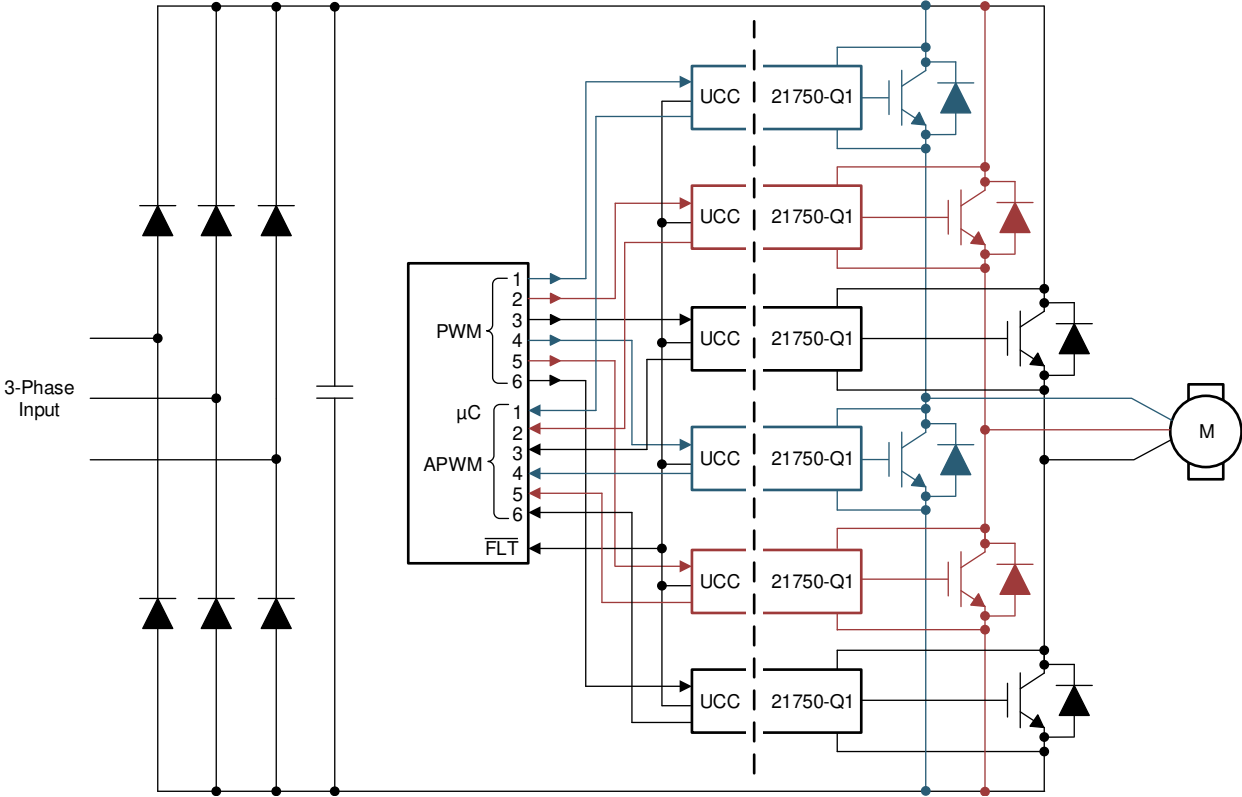

Figure 39. Typical Application Schematic

9.2.1 Design Requirements

The design of the power system for end equipment should consider some design requirements to ensure the reliable operation of UCC1750-Q1 through the load range. The design considerations include the peak source and sink current, power dissipation, overcurrent and short circuit protection, AIN-APWM function for analog signal sensing and etc.

A design example for a half bridge based on IGBT is given in this subsection. The design parameters are show in .

Table 2. Design Parameters

| Parameter | Value |
|-----------------------------|---------------|
| Input Supply Voltage | 5V |
| IN-OUT Configuration | Non-inverting |
| Positive Output Voltage VDD | 15V |
| Negative Output Voltage VEE | -5V |
| DC Bus Voltage | 800V |
| Peak Drain Current | 300A |
| Switching Frequency | 50kHz |
| Switch Type | IGBT Module |

ADVANCE INFORMATION

9.2.2 Detailed Design Procedure

9.2.2.1 Input filters for IN+, IN- and RST/EN

In the applications of traction inverter or motor drive, the power semiconductors are in hard switching mode. With the strong drive strength of UCC21750-Q1, the dV/dt can be high, especially for SiC MOSFET. Noise can not only be coupled to the gate voltage due to the parasitic inductance, but also to the input side as the non-ideal PCB layout and coupled capacitance.

UCC21750-Q1 features a 40ns internal deglitch filter to IN+, IN- and RST/EN pin. Any signal less than 40ns can be filtered out from the input pins. For noisy systems, external low pass filter can be added externally to the input pins. Adding low pass filters to IN+, IN- and RST/EN pins can effectively increase the noise immunity and increase the signal integrity. When not in use, the IN+, IN- and RST/EN pins should not be floating. IN- should be tied to GND if only IN+ is used for non-inverting input to output configuration. The purpose of the low pass filter is to filter out the high frequency noise generated by the layout parasitics. While choosing the low pass filter resistors and capacitors, both the noise immunity effect and delay time should be considered according to the system requirements.

9.2.2.2 PWM Interlock of IN+ and IN-

UCC21750-Q1 features the PWM interlock for IN+ and IN- pins, which can be used to prevent the phase leg shoot through issue. As shown in , the output is logic low while both IN+ and IN- are logic high. When only IN+ is used, IN- can be tied to GND. To utilize the PWM interlock function, the PWM signal of the other switch in the phase leg can be sent to the IN- pin. As shown in , the PWM_T is the PWM signal to top side switch, the PWM_B is the PWM signal to bottom side switch. For the top side gate driver, the PWM_T signal is given to the IN+ pin, while the PWM_B signal is given to the IN- pin; for the bottom side gate driver, the PWM_B signal is given to the IN+ pin, while PWM_T signal is given to the IN- pin. When both PWM_T and PWM_B signals are high, the outputs of both gate drivers are logic low to prevent the shoot through condition.

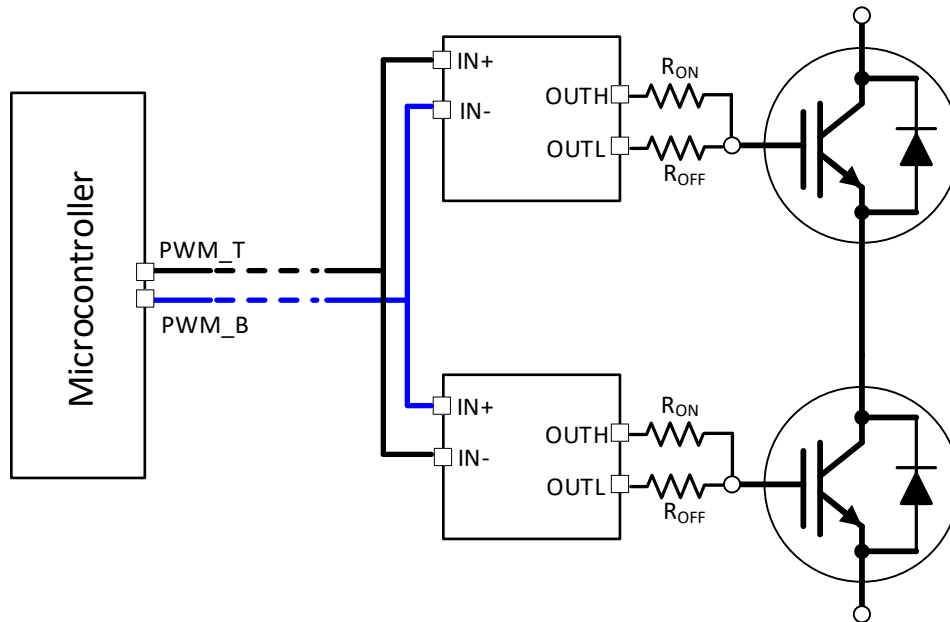

Figure 40. PWM Interlock for a Half Bridge

9.2.2.3 FLT, RDY and RST/EN Pin Circuitry

Both FLT and RDY pin are open-drain output. The RST/EN pin has 50kΩ internal pull-down resistor, so the driver is in OFF status if the RST/EN pin is not pulled up externally. A 5kΩ resistor can be used as pullup resistor for the FLT, RDY and RST/EN pins.

To improve the noise immunity due to the parasitic coupling and common mode noise, low pass filters can be added between the FLT, RDY and RST/EN pins and the microcontroller. A filter capacitor between 100pF to 300pF can be added.

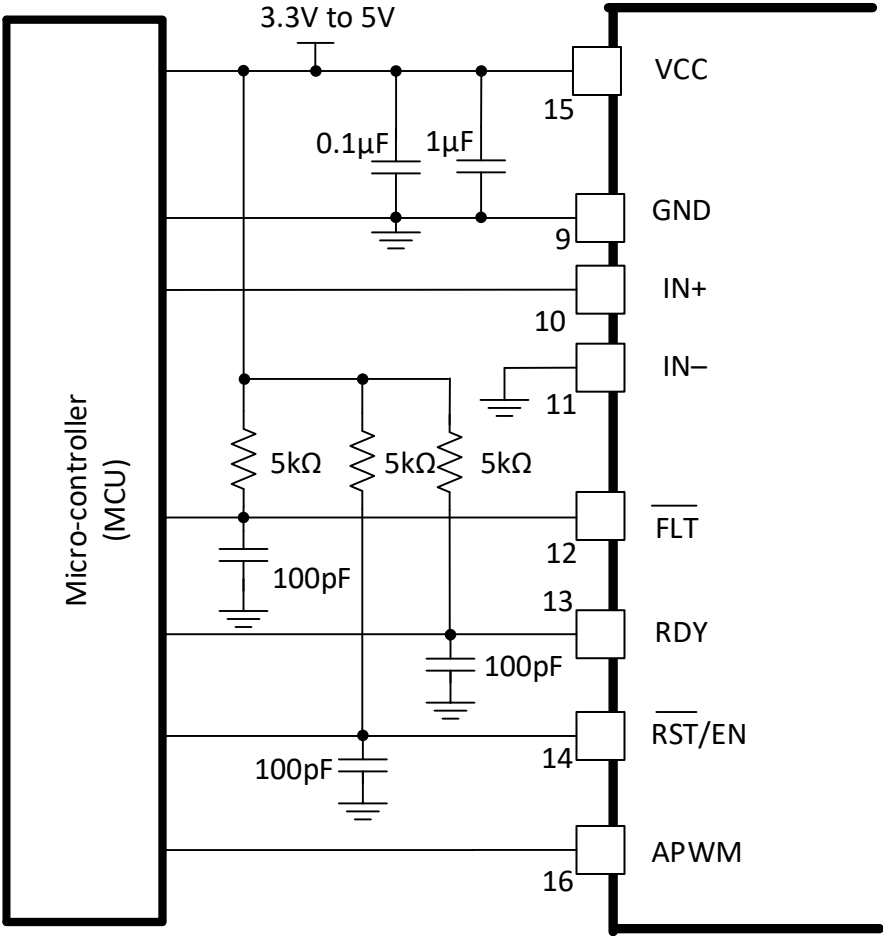

Figure 41. $\overline{\text{FLT}}$, RDY and $\overline{\text{RST/EN}}$ Pins Circuitry

9.2.2.4 $\overline{\text{RST/EN}}$ Pin Control

$\overline{\text{RST/EN}}$ pin has two functions. It can be used to enable and shutdown the outputs of the driver, and reset the fault signaled on the $\overline{\text{FLT}}$ pin. $\overline{\text{RST/EN}}$ pin needs to be pulled up to enable the device; when the pin is pulled down, the device is in disabled status. With a 50kΩ pulldown resistor existing, the driver is disabled by default.

When the driver is latched after overcurrent or short circuit fault is detected, the $\overline{\text{FLT}}$ pin and output are latched low and need to be reset by $\overline{\text{RST/EN}}$ pin. $\overline{\text{RST/EN}}$ pin is active low. The microcontroller needs to send a signal to $\overline{\text{RST/EN}}$ pin after the fault mute time t_{FLTMUTE} to reset the driver. This pin can also be used to automatically reset the driver. The continuous input signal IN+ or IN- can be applied to $\overline{\text{RST/EN}}$ pin, so the microcontroller does not need to generate another control signal to reset the driver. If non-inverting input IN+ is used, then IN+ can be tied to $\overline{\text{RST/EN}}$ pin. If inverting input IN- is used, then a NOT logic is needed between the inverting PWM signal from the microcontroller and the $\overline{\text{RST/EN}}$ pin. In this case, the driver can be reset in every switching cycle without an extra control signal from microcontroller to $\overline{\text{RST/EN}}$ pin.

ADVANCE INFORMATION

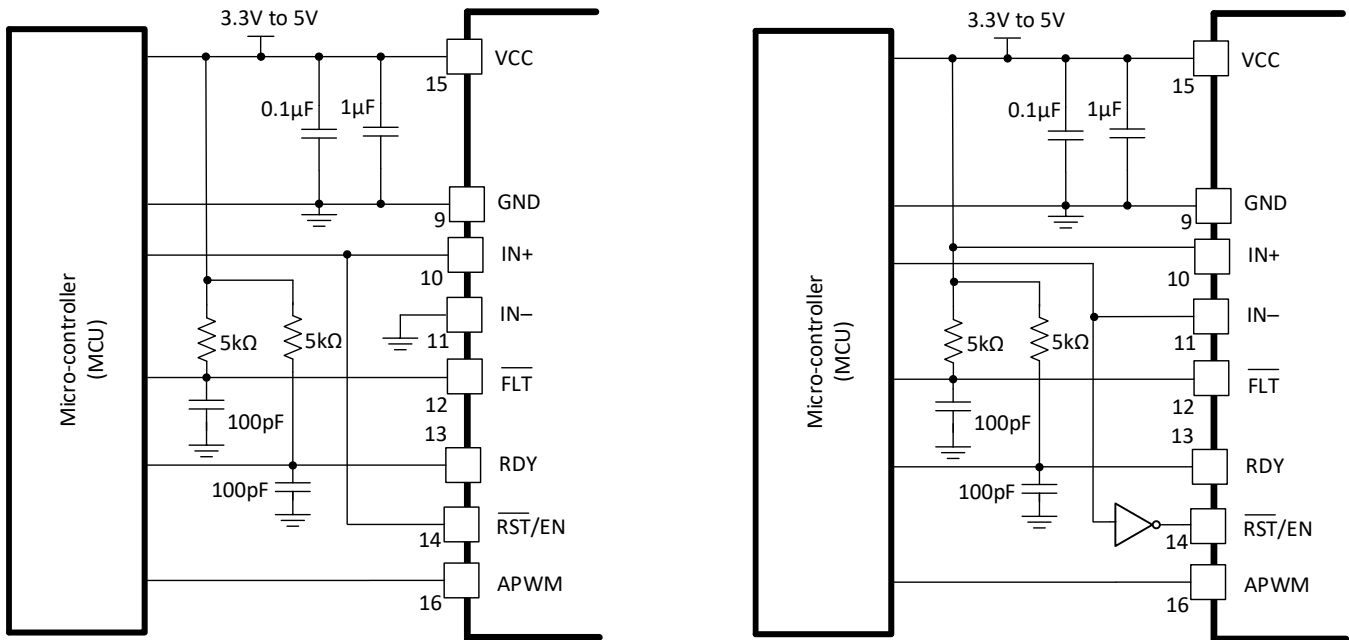
Figure 42. Automatic Reset Control

9.2.2.5 Turn on and turn off gate resistors

UCC21750-Q1 features split outputs OUTH and OUTL, which enables the independent control of the turn on and turn off switching speed. The turn on and turn off resistance determine the peak source and sink current, which controls the switching speed in turn. Meanwhile, the power dissipation in the gate driver should be considered to ensure the device is in the thermal limit. At first, the peak source and sink current are calculated as:

$$I_{\text{source_pk}} = \min\left(10\text{A}, \frac{V_{\text{DD}} - V_{\text{EE}}}{R_{\text{OH_EFF}} + R_{\text{ON}} + R_{\text{G_Int}}}\right)$$

$$I_{\text{sink_pk}} = \min\left(10\text{A}, \frac{V_{\text{DD}} - V_{\text{EE}}}{R_{\text{OL}} + R_{\text{OFF}} + R_{\text{G_Int}}}\right)$$

(1)

Where

- $R_{\text{OH_EFF}}$ is the effective internal pull up resistance of the hybrid pull-up structure, which is approximately $2 \times R_{\text{OL}}$, about 0.7Ω
- R_{OL} is the internal pulldown resistance, about 0.3Ω
- R_{ON} is the external turn on gate resistance
- R_{OFF} is the external turn off gate resistance
- $R_{\text{G_Int}}$ is the internal resistance of the SiC MOSFET or IGBT module

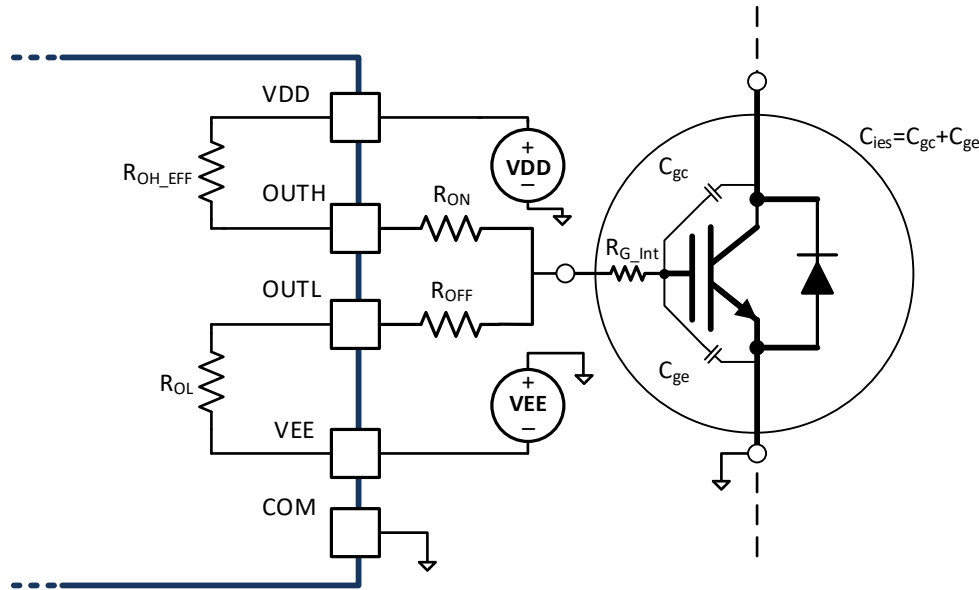

Figure 43. Output Model for Calculating Peak Gate Current

For example, for an IGBT module based system with the following parameters:

- $Q_g = 3300 \text{ nC}$
- $R_{G_Int} = 1.7 \text{ } \Omega$
- $R_{ON} = R_{OFF} = 1 \text{ } \Omega$

The peak source and sink current in this case are:

$$I_{\text{source_pk}} = \min\left(10\text{A}, \frac{V_{DD} - V_{EE}}{R_{OH_EFF} + R_{ON} + R_{G_Int}}\right) \approx 5.9\text{A}$$

$$I_{\text{sink_pk}} = \min\left(10\text{A}, \frac{V_{DD} - V_{EE}}{R_{OL} + R_{OFF} + R_{G_Int}}\right) \approx 6.7\text{A} \quad (2)$$

Thus by using $1\text{ } \Omega$ external gate resistance, the peak source current is 5.9A , the peak sink current is 6.7A . The collector-to-emitter dV/dt during the turn on switching transient is dominated by the gate current at the miller plateau voltage. The hybrid pullup structure ensures the peak source current at the miller plateau voltage, unless the turn on gate resistor is too high. The faster the collector-to-emitter, V_{ce} , voltage rises to V_{DC} , the smaller the turn on switching loss is. The dV/dt can be estimated as $Q_{gc}/I_{\text{source_pk}}$. For the turn off switching transient, the drain-to-source dV/dt is dominated by the load current, unless the turn off gate resistor is too high. After V_{ce} reaches the dc bus voltage, the power semiconductor is in saturation mode and the channel current is controlled by V_{ge} . The peak sink current determines the dI/dt , which dominates the V_{ce} voltage overshoot accordingly. If using relatively large turn off gate resistance, the V_{ce} overshoot can be limited. The overshoot can be estimated by:

$$\Delta V_{ce} = L_{\text{stray}} \cdot I_{\text{load}} / ((R_{OFF} + R_{OL} + R_{G_Int}) \cdot C_{ies} \cdot \ln(V_{\text{plat}} / V_{th})) \quad (3)$$

Where

- L_{stray} is the stray inductance in power switching loop, as shown in Figure 44
- I_{load} is the load current, which is the turn off current of the power semiconductor
- C_{ies} is the input capacitance of the power semiconductor
- V_{plat} is the plateau voltage of the power semiconductor
- V_{th} is the threshold voltage of the power semiconductor

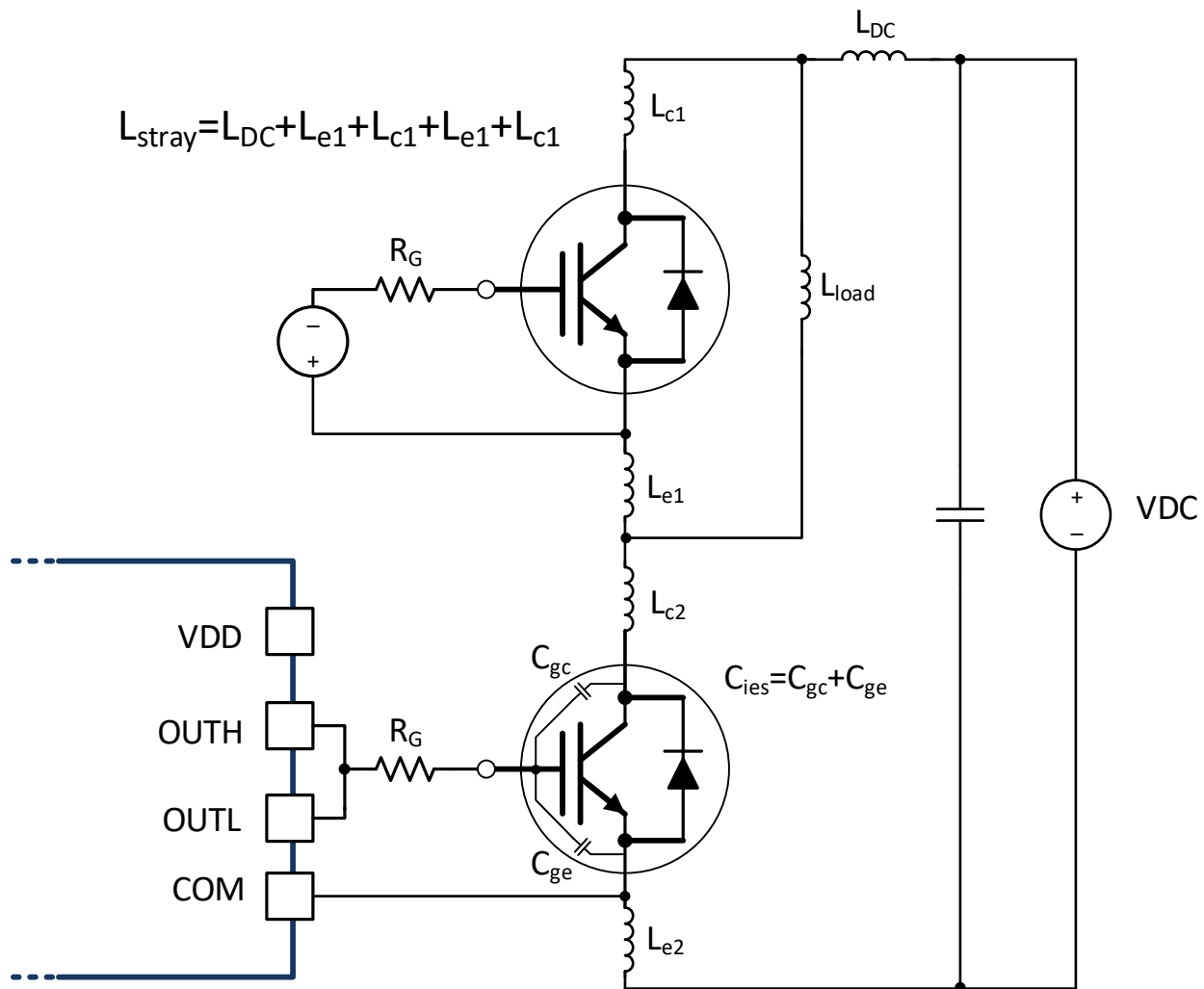
Figure 44. Stray Parasitic Inductance of IGBTs in a Half-Bridge Configuration

The power dissipation should be taken into account to maintain the gate driver within the thermal limit. The power loss of the gate driver includes the quiescent loss and the switching loss, which can be calculated as:

$$P_{DR} = P_Q + P_{SW} \quad (4)$$

P_Q is the quiescent power loss for the driver, which is $I_q \times (V_{DD} - V_{EE}) = 5\text{mA} \times 20\text{V} = 0.100\text{W}$. The quiescent power loss is the power consumed by the internal circuits such as the input stage, reference voltage, logic circuits, protection circuits when the driver is switching when the driver is biased with V_{DD} and V_{EE} , and also the charging and discharging current of the internal circuit when the driver is switching. The power dissipation when the driver is switching can be calculated as:

$$P_{SW} = \frac{1}{2} \cdot \left(\frac{R_{OH_EFF}}{R_{OH_EFF} + R_{ON} + R_{G_Int}} + \frac{R_{OL}}{R_{OL} + R_{OFF} + R_{G_Int}} \right) \cdot (V_{DD} - V_{EE}) \cdot f_{sw} \cdot Q_g \quad (5)$$

Where

- Q_g is the gate charge required at the operation point to fully charge the gate voltage from V_{EE} to V_{DD}
- f_{sw} is the switching frequency

In this example, the P_{SW} can be calculated as:

$$P_{SW} = \frac{1}{2} \cdot \left(\frac{R_{OH_EFF}}{R_{OH_EFF} + R_{ON} + R_{G_Int}} + \frac{R_{OL}}{R_{OL} + R_{OFF} + R_{G_Int}} \right) \cdot (V_{DD} - V_{EE}) \cdot f_{sw} \cdot Q_g = 0.505\text{W} \quad (6)$$

Thus, the total power loss is:

$$P_{DR} = P_Q + P_{SW} = 0.10W + 0.505W = 0.605W \quad (7)$$

When the board temperature is 125°C, the junction temperature can be estimated as:

$$T_j = T_b + \psi_{jb} \cdot P_{DR} \approx 150^\circ\text{C} \quad (8)$$

Therefore, for the application in this example, with 125°C board temperature, the maximum switching frequency is ~50kHz to keep the gate driver in the thermal limit. By using a lower switching frequency, or increasing external gate resistance, the gate driver can be operated at a higher switching frequency.

9.2.2.6 Overcurrent and Short Circuit Protection

A standard desaturation circuit can be applied to the DESAT pin. If the voltage of the DESAT pin is higher than the threshold V_{DESAT} , the soft turn-off is initiated. A fault will be reported to the input side to DSP/MCU. The output is held to LOW after the fault is detected, and can only be reset by the RST/EN pin. The state-of-art overcurrent and short circuit detection time helps to ensure a short shutdown time for SiC MOSFET and IGBT.

If DESAT pin is not in use, it must be tied to COM to avoid overcurrent fault false triggering.

- Fast reverser recovery high voltage diode is recommended in the desaturation circuit. A resistor is recommended in series with the high voltage diode to limit the inrush current.
- A diode is recommended from COM to DESAT to prevent driver damage caused by negative voltage

9.2.2.7 Isolated Analog Signal Sensing

The isolated analog signal sensing feature provides a simple isolated channel for the isolated temperature detection, voltage sensing and etc. One typical application of this function is the temperature monitor of the power semiconductor. Thermal diodes or temperature sensing resistors are integrated in the SiC MOSFET or IGBT module close to the dies to monitor the junction temperature. UCC21750-Q1 has an internal 200uA current source with 3% accuracy across temperature, which can forward bias the thermal diodes or create a voltage drop on the temperature sensing resistors. The sensed voltage from the AIN pin is passed through the isolation barrier to the input side and transformed to a PWM signal. The duty cycle of the PWM changes linearly from 10% to 88% when the AIN voltage changes from 4.5V to 0.6V and can be represented using [Equation 9](#).

$$D_{APWM}(\%) = -20 * V_{AIN} + 100 \quad (9)$$

9.2.2.7.1 Isolated Temperature Sensing

A typical application circuit is shown in [Figure 45](#). To sense temperature, the AIN pin is connected to the thermal diode or thermistor which can be discrete or integrated within the power module. A low pass filter is recommended for the AIN input. Since the temperature signal does not have a high bandwidth, the low pass filter is mainly used for filtering the noise introduced by the switching of the power device, which does not require stringent control for propagation delay. The filter capacitance for C_{filt} can be chosen between 1nF to 100nF and the filter resistance R_{filt} between 1Ω to 10Ω according to the noise level.

The output of APWM is directly connected to the microcontroller to measure the duty cycle dependent on the voltage input at AIN, using [Equation 9](#).

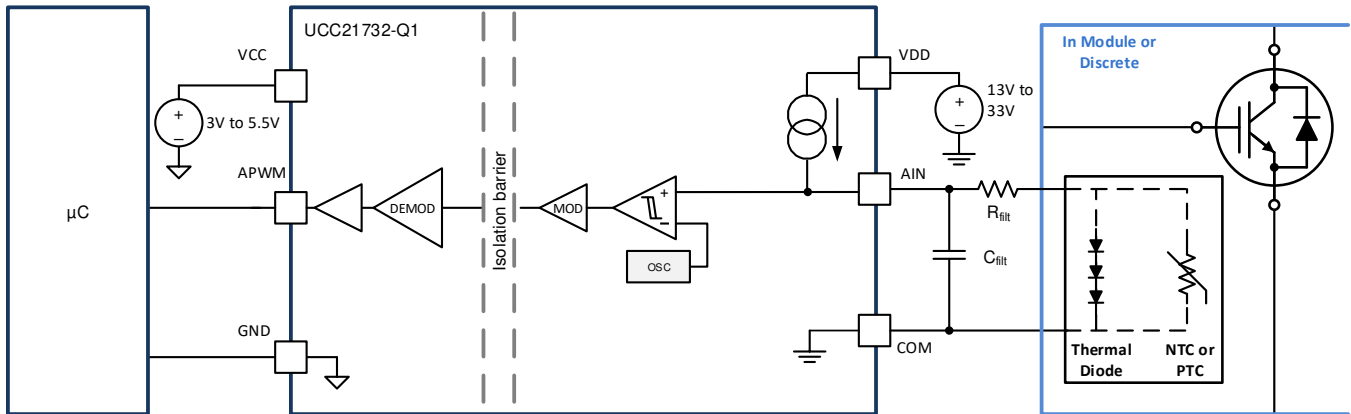

Figure 45. Thermal Diode or Thermistor Temperature Sensing Configuration

When a high-precision voltage supply for VCC is used on the primary side of UCC21750-Q1 the duty cycle output of APWM may also be filtered and the voltage measured using the microcontroller's ADC input pin, as shown in Figure 46. The frequency of APWM is 400kHz, so the value for R_{filt_2} and C_{filt_2} should be such that the cutoff frequency is below 400kHz. Temperature does not change rapidly, thus the rise time due to the RC constant of the filter is not under a strict requirement.

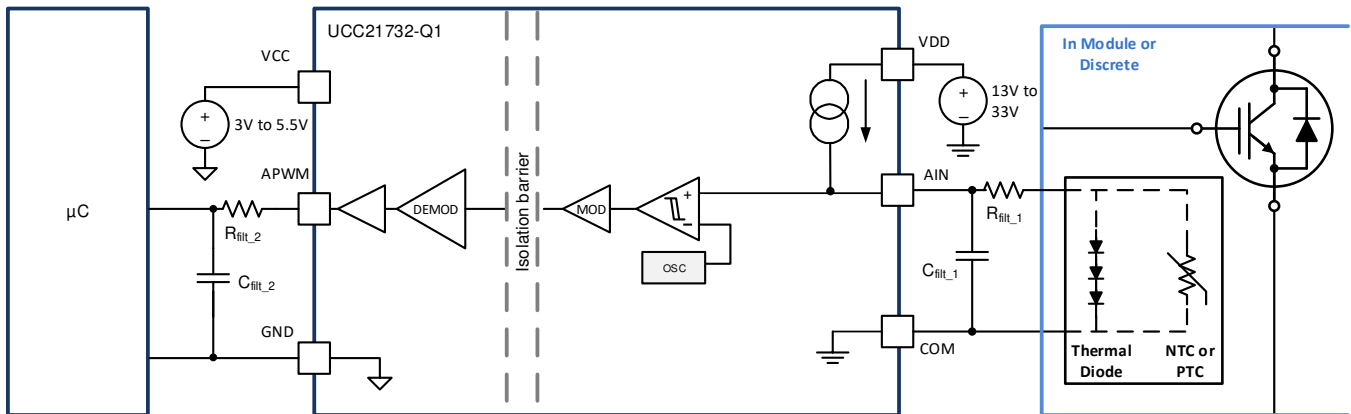

Figure 46. APWM Channel with Filtered Output

The example below shows the results using a 4.7kΩ NTC, NTCS0805E3472FMT, in series with a 3kΩ resistor and also the thermal diode using four diode-connected MMBT3904 NPN transistors. The sensed voltage of the 4 MMBT3904 thermal diodes connected in series ranges from about 2.5V to 1.6V from 25°C to 135°C, corresponding to 50% to 68% duty cycle. The sensed voltage of the NTC thermistor connected in series with the 3kΩ resistor ranges from about 1.5V to 0.6V from 25°C to 135°C, corresponding to 70% to 88% duty cycle. The voltage at VAIN of both sensors and the corresponding measured duty cycle at APWM is shown in Figure 47.

ADVANCE INFORMATION

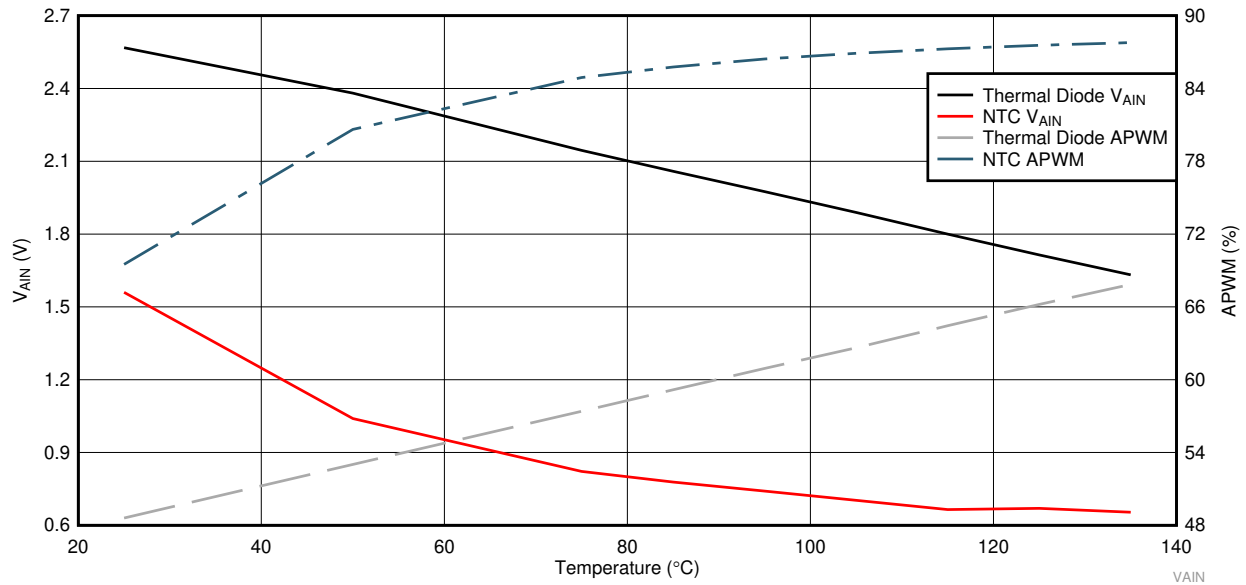

Figure 47. Thermal diode and NTC V_{AIN} and Corresponding Duty Cycle at APWM

The duty cycle output has an accuracy of $\pm 3\%$ throughout temperature without any calibration, as shown in Figure 48 but with single-point calibration at 25°C, the duty accuracy can be improved to $\pm 1\%$, as shown in Figure 49.

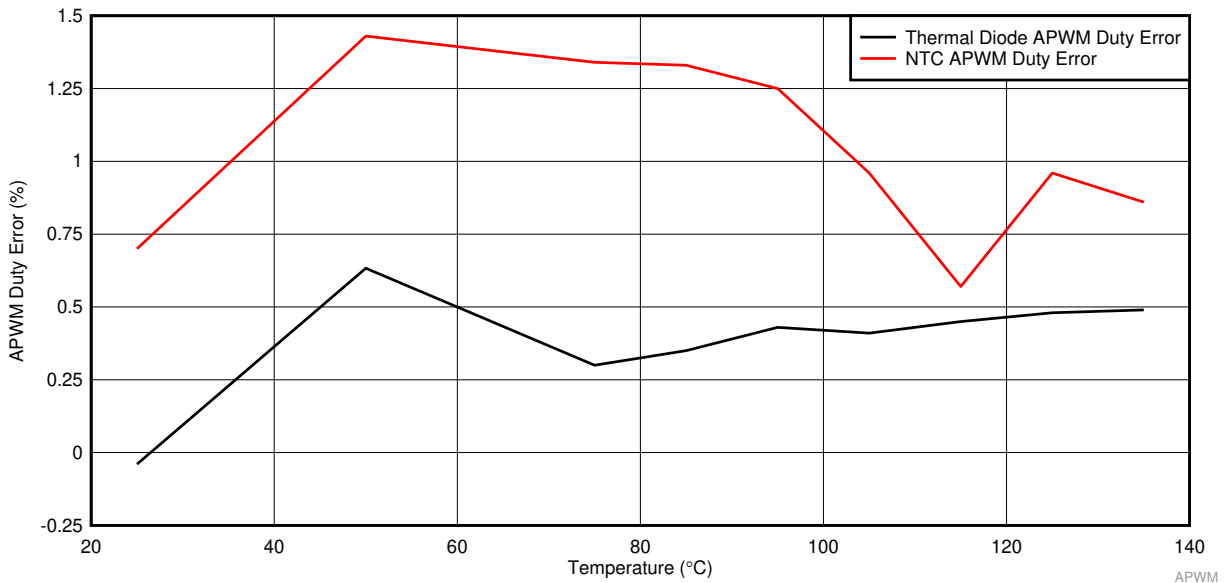

Figure 48. APWM Duty Error Without Calibration

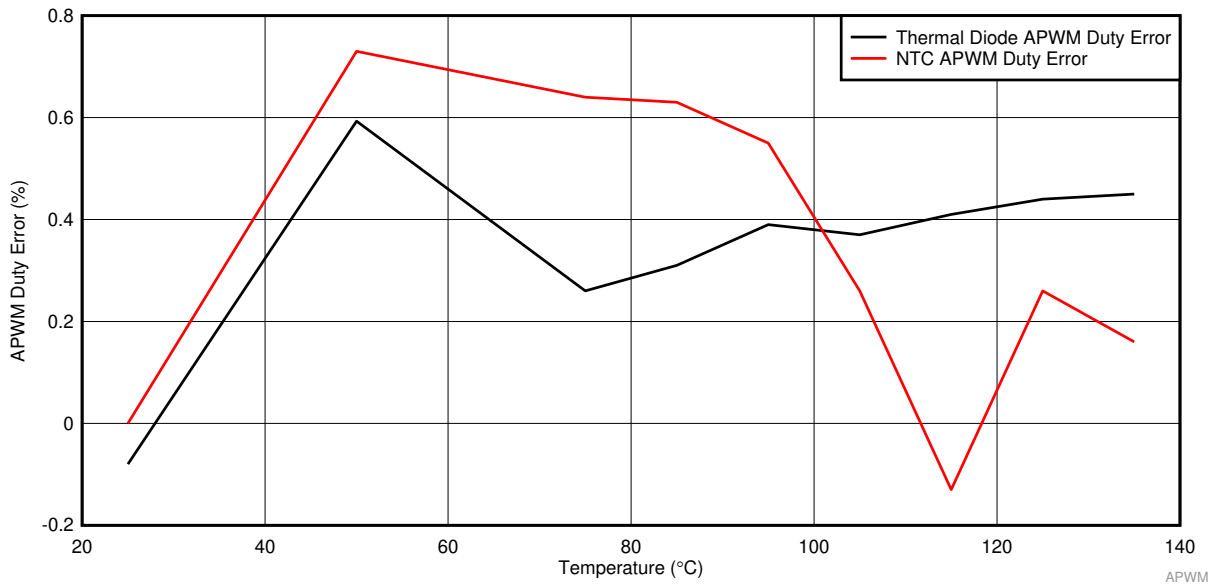

Figure 49. APWM Duty Error with Single-Point Calibration

9.2.2.7.2 Isolated DC Bus Voltage Sensing

The AIN to APWM channel may be used for other applications such as the DC-link voltage sensing, as shown in Figure 50. The same filtering requirements as given above may be used in this case, as well. The number of attenuation resistors, R_{atten_1} through R_{atten_n} , is dependent on the voltage level and power rating of the resistor. The voltage is finally measured across R_{LV_DC} to monitor the stepped-down voltage of the HV DC-link which must fall within the voltage range of AIN from 0.6V to 4.5V. The driver should be referenced to the same point as the measurement reference, thus in the case shown below the UCC21750-Q1 is driving the lower IGBT in the half-bridge and the DC-link voltage measurement is referenced to COM. The internal current source I_{AIN} should be taken into account when designing the resistor divider. The AIN pin voltage is:

$$V_{AIN} = \frac{R_{LV_DC}}{R_{LV_DC} + \sum_{i=1}^n R_{atten_i}} \cdot V_{DC} + R_{LV_DC} \cdot I_{AIN} \tag{10}$$

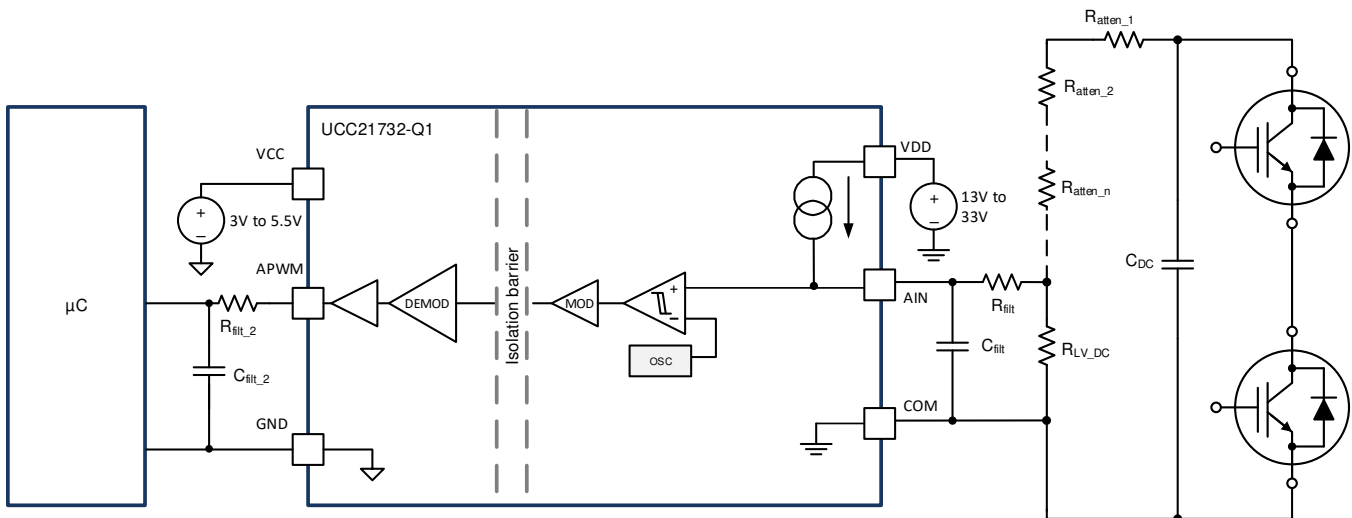

Figure 50. DC-link Voltage Sensing Configuration

9.2.2.8 Higher Output Current Using an External Current Buffer

To increase the IGBT gate drive current, a non-inverting current buffer (such as the NPN/PNP buffer shown in Figure 51) can be used. Inverting types are not compatible with the desaturation fault protection circuitry and must be avoided. The MJD44H11/MJD45H11 pair is appropriate for peak currents up to 15 A, the D44VH10/D45VH10 pair is up to 20 A peak.

In the case of a over-current detection, the soft turn off (STO) is activated. External components must be added to implement STO instead of normal turn off speed when an external buffer is used. C_{STO} sets the timing for soft turn off and R_{STO} limits the inrush current to below the current rating of the internal FET (10A). R_{STO} should be at least (VDD-VEE)/10. The soft turn off timing is determined by the internal current source of 400mA and the capacitor C_{STO}. C_{STO} is calculated using .

$$C_{STO} = \frac{I_{STO} \cdot t_{STO}}{VDD - VEE} \tag{11}$$

- I_{STO} is the the internal STO current source, 400mA
- t_{STO} is the desired STO timing

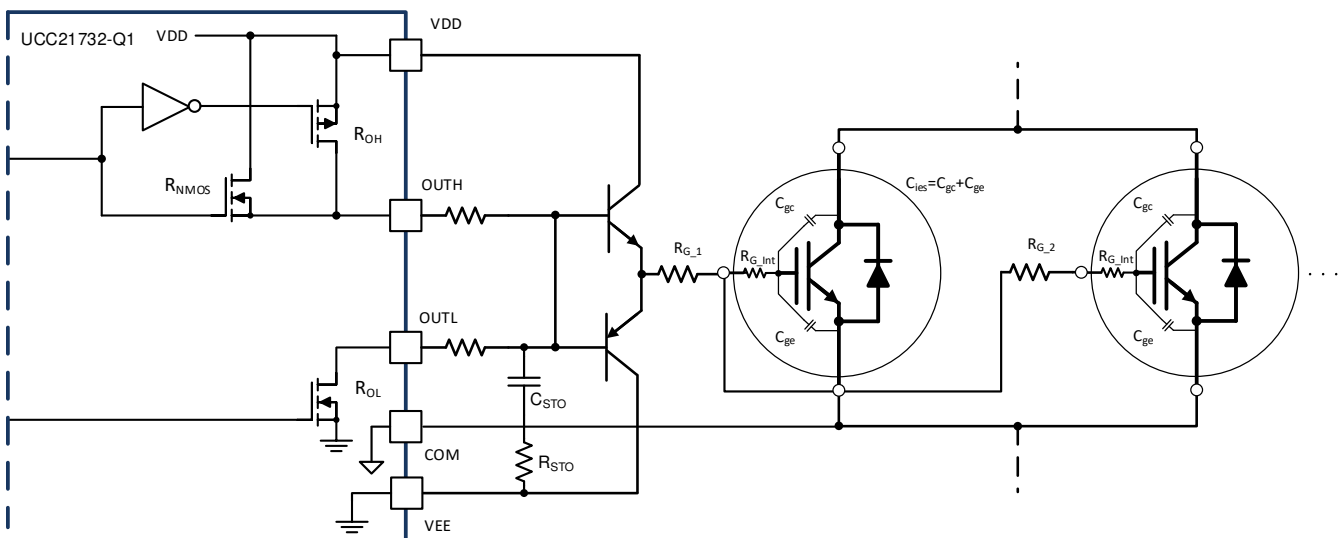

Figure 51. Current Buffer for Increased Drive Strength

10 Power Supply Recommendations

During the turn on and turn off switching transient, the peak source and sink current is provided by the VDD and VEE power supply. The large peak current is possible to drain the VDD and VEE voltage level and cause a voltage droop on the power supplies. To stabilize the power supply and ensure a reliable operation, a set of decoupling capacitors are recommended at the power supplies. Considering UCC21750-Q1 has ±10A peak drive strength and can generate high dV/dt, a 10µF bypass cap is recommended between VDD and COM, VEE and COM. A 1µF bypass cap is recommended between VCC and GND due to less current comparing with output side power supplies. A 0.1µF decoupling cap is also recommended for each power supply to filter out high frequency noise. The decoupling capacitors must be low ESR and ESL to avoid high frequency noise, and should be placed as close as possible to the VCC, VDD and VEE pins to prevent noise coupling from the system parasitics of PCB layout.

ADVANCE INFORMATION

11 Layout

11.1 Layout Guidelines

Due to the strong drive strength of UCC21750-Q1, careful considerations must be taken in PCB design. Below are some key points:

- The driver should be placed as close as possible to the power semiconductor to reduce the parasitic inductance of the gate loop on the PCB traces
- The decoupling capacitors of the input and output power supplies should be placed as close as possible to the power supply pins. The peak current generated at each switching transient can cause high di/dt and voltage spike on the parasitic inductance of PCB traces
- The driver COM pin should be connected to the Kelvin connection of SiC MOSFET source or IGBT emitter. If the power device does not have a split Kelvin source or emitter, the COM pin should be connected as close as possible to the source or emitter terminal of the power device package to separate the gate loop from the high power switching loop
- Use a ground plane on the input side to shield the input signals. The input signals can be distorted by the high frequency noise generated by the output side switching transients. The ground plane provides a low-inductance filter for the return current flow
- If the gate driver is used for the low side switch which the COM pin connected to the dc bus negative, use the ground plane on the output side to shield the output signals from the noise generated by the switch node; if the gate driver is used for the high side switch, which the COM pin is connected to the switch node, ground plane is not recommended
- If ground plane is not used on the output side, separate the return path of the DESAT and AIN ground loop from the gate loop ground which has large peak source and sink current
- No PCB trace or copper is allowed under the gate driver. A PCB cutout is recommended to avoid any noise coupling between the input and output side which can contaminate the isolation barrier

11.2 Layout Example

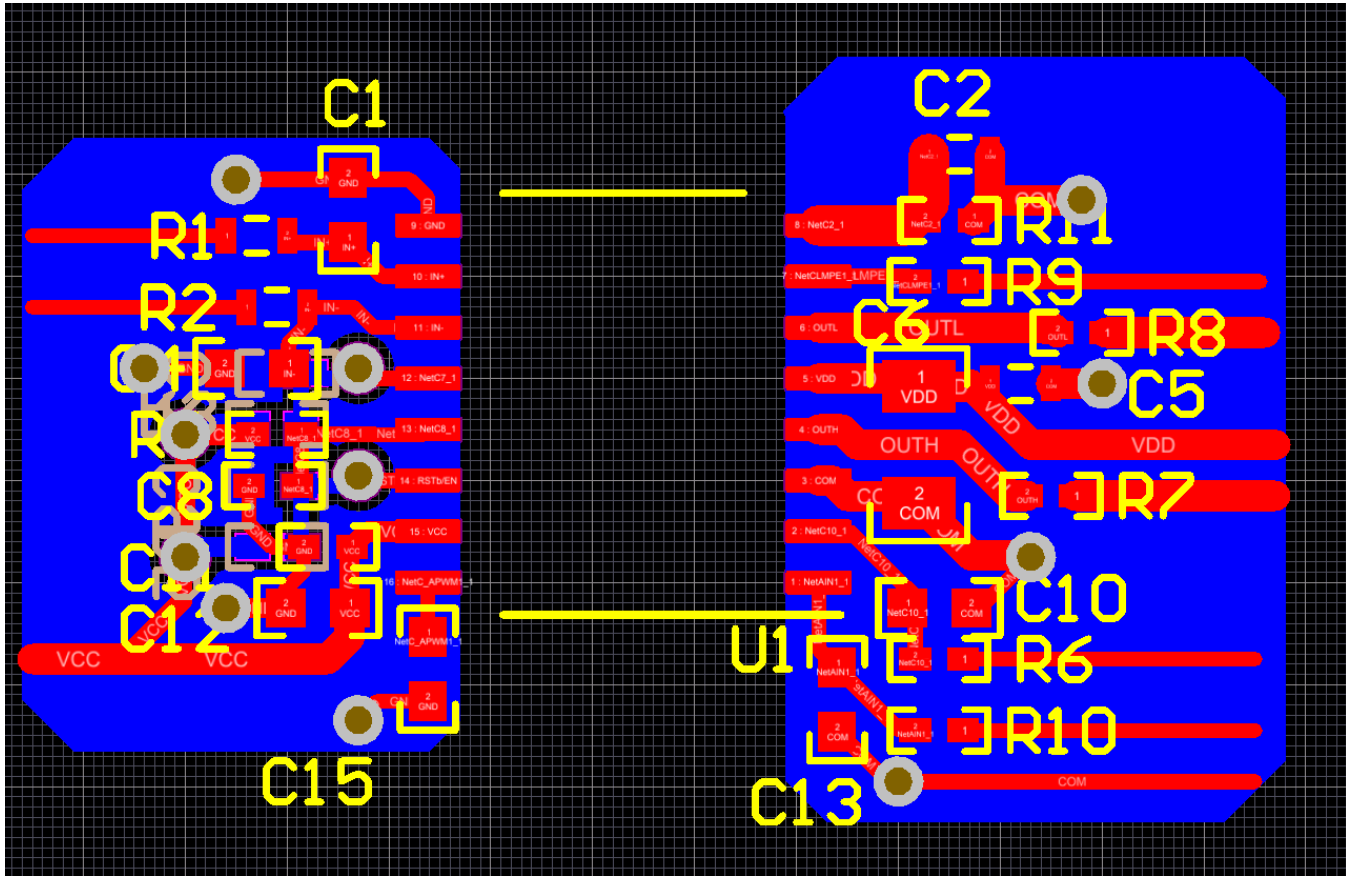

Figure 52. Layout Example

ADVANCE INFORMATION

12 Device and Documentation Support

12.1 Documentation Support

12.1.1 Related Documentation

For related documentation see the following:

- [Isolation Glossary](#)

12.2 Receiving Notification of Documentation Updates

To receive notification of documentation updates, navigate to the device product folder on ti.com. In the upper right corner, click on *Alert me* to register and receive a weekly digest of any product information that has changed. For change details, review the revision history included in any revised document.

12.3 Community Resource

TI E2E™ support forums are an engineer's go-to source for fast, verified answers and design help — straight from the experts. Search existing answers or ask your own question to get the quick design help you need.

Linked content is provided "AS IS" by the respective contributors. They do not constitute TI specifications and do not necessarily reflect TI's views; see TI's [Terms of Use](#).

12.4 Trademarks

E2E is a trademark of Texas Instruments.

12.5 Electrostatic Discharge Caution



This integrated circuit can be damaged by ESD. Texas Instruments recommends that all integrated circuits be handled with appropriate precautions. Failure to observe proper handling and installation procedures can cause damage.

ESD damage can range from subtle performance degradation to complete device failure. Precision integrated circuits may be more susceptible to damage because very small parametric changes could cause the device not to meet its published specifications.

12.6 Glossary

[SLYZ022](#) — *TI Glossary*.

This glossary lists and explains terms, acronyms, and definitions.

13 Mechanical, Packaging, and Orderable Information

The following pages include mechanical packaging and orderable information. This information is the most current data available for the designated devices. This data is subject to change without notice and revision of this document. For browser-based versions of this data sheet, refer to the left-hand navigation.

MECHANICAL DATA

DW (R-PDSO-G16)

PLASTIC SMALL OUTLINE

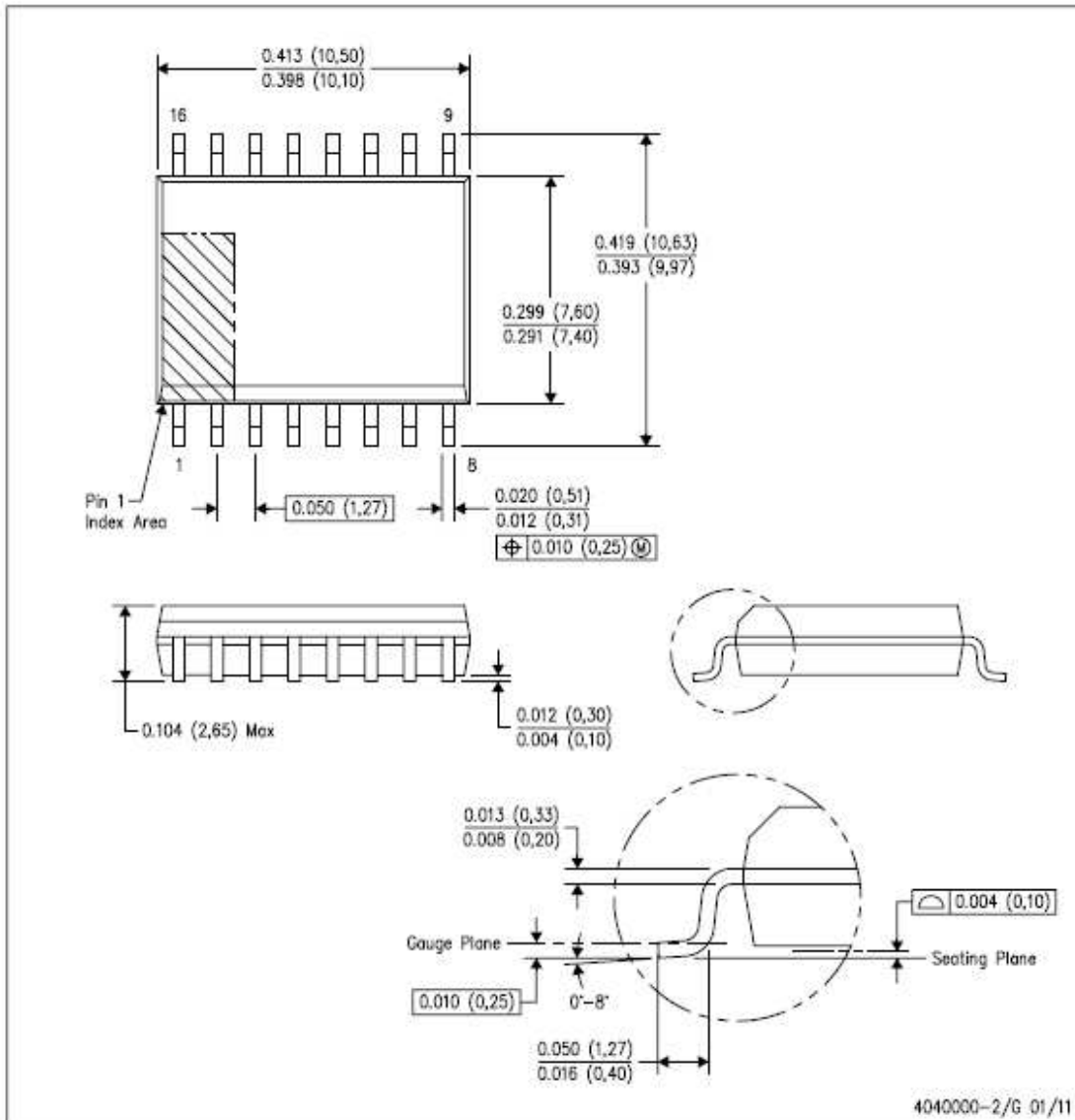

- NOTES:
- A. All linear dimensions are in inches (millimeters). Dimensioning and tolerancing per ASME Y14.5M-1994.
 - B. This drawing is subject to change without notice.
 - C. Body dimensions do not include mold flash or protrusion not to exceed 0.006 (0,15).
 - D. Falls within JEDEC MS-013 variation AA.

PACKAGING INFORMATION

| Orderable Device | Status (1) | Package Type | Package Drawing | Pins | Package Qty | Eco Plan (2) | Lead/Ball Finish (6) | MSL Peak Temp (3) | Op Temp (°C) | Device Marking (4/5) | Samples |
|------------------|---------------|--------------|-----------------|------|-------------|-----------------|-------------------------|----------------------|--------------|-------------------------|---------|
| PUCC21750QDWRQ1 | ACTIVE | SOIC | DW | 16 | 2000 | TBD | Call TI | Call TI | -40 to 125 | | Samples |
| UCC21750QDWQ1 | PREVIEW | SOIC | DW | 16 | 40 | TBD | Call TI | Call TI | -40 to 125 | | |
| UCC21750QDWRQ1 | PREVIEW | SOIC | DW | 16 | 2000 | TBD | Call TI | Call TI | -40 to 125 | | |

(1) The marketing status values are defined as follows:

ACTIVE: Product device recommended for new designs.

LIFEBUY: TI has announced that the device will be discontinued, and a lifetime-buy period is in effect.

NRND: Not recommended for new designs. Device is in production to support existing customers, but TI does not recommend using this part in a new design.

PREVIEW: Device has been announced but is not in production. Samples may or may not be available.

OBSELETE: TI has discontinued the production of the device.

(2) **RoHS:** TI defines "RoHS" to mean semiconductor products that are compliant with the current EU RoHS requirements for all 10 RoHS substances, including the requirement that RoHS substance do not exceed 0.1% by weight in homogeneous materials. Where designed to be soldered at high temperatures, "RoHS" products are suitable for use in specified lead-free processes. TI may reference these types of products as "Pb-Free".

RoHS Exempt: TI defines "RoHS Exempt" to mean products that contain lead but are compliant with EU RoHS pursuant to a specific EU RoHS exemption.

Green: TI defines "Green" to mean the content of Chlorine (Cl) and Bromine (Br) based flame retardants meet JS709B low halogen requirements of <=1000ppm threshold. Antimony trioxide based flame retardants must also meet the <=1000ppm threshold requirement.

(3) MSL, Peak Temp. - The Moisture Sensitivity Level rating according to the JEDEC industry standard classifications, and peak solder temperature.

(4) There may be additional marking, which relates to the logo, the lot trace code information, or the environmental category on the device.

(5) Multiple Device Markings will be inside parentheses. Only one Device Marking contained in parentheses and separated by a "-" will appear on a device. If a line is indented then it is a continuation of the previous line and the two combined represent the entire Device Marking for that device.

(6) Lead/Ball Finish - Orderable Devices may have multiple material finish options. Finish options are separated by a vertical ruled line. Lead/Ball Finish values may wrap to two lines if the finish value exceeds the maximum column width.

Important Information and Disclaimer:The information provided on this page represents TI's knowledge and belief as of the date that it is provided. TI bases its knowledge and belief on information provided by third parties, and makes no representation or warranty as to the accuracy of such information. Efforts are underway to better integrate information from third parties. TI has taken and continues to take reasonable steps to provide representative and accurate information but may not have conducted destructive testing or chemical analysis on incoming materials and chemicals. TI and TI suppliers consider certain information to be proprietary, and thus CAS numbers and other limited information may not be available for release.

In no event shall TI's liability arising out of such information exceed the total purchase price of the TI part(s) at issue in this document sold by TI to Customer on an annual basis.

OTHER QUALIFIED VERSIONS OF UCC21750-Q1 :

- Catalog: [UCC21750](#)

NOTE: Qualified Version Definitions:

- Catalog - TI's standard catalog product

GENERIC PACKAGE VIEW

DW 16

SOIC - 2.65 mm max height

7.5 x 10.3, 1.27 mm pitch

SMALL OUTLINE INTEGRATED CIRCUIT

This image is a representation of the package family, actual package may vary.
Refer to the product data sheet for package details.



4224780/A

IMPORTANT NOTICE AND DISCLAIMER

TI PROVIDES TECHNICAL AND RELIABILITY DATA (INCLUDING DATASHEETS), DESIGN RESOURCES (INCLUDING REFERENCE DESIGNS), APPLICATION OR OTHER DESIGN ADVICE, WEB TOOLS, SAFETY INFORMATION, AND OTHER RESOURCES "AS IS" AND WITH ALL FAULTS, AND DISCLAIMS ALL WARRANTIES, EXPRESS AND IMPLIED, INCLUDING WITHOUT LIMITATION ANY IMPLIED WARRANTIES OF MERCHANTABILITY, FITNESS FOR A PARTICULAR PURPOSE OR NON-INFRINGEMENT OF THIRD PARTY INTELLECTUAL PROPERTY RIGHTS.

These resources are intended for skilled developers designing with TI products. You are solely responsible for (1) selecting the appropriate TI products for your application, (2) designing, validating and testing your application, and (3) ensuring your application meets applicable standards, and any other safety, security, or other requirements. These resources are subject to change without notice. TI grants you permission to use these resources only for development of an application that uses the TI products described in the resource. Other reproduction and display of these resources is prohibited. No license is granted to any other TI intellectual property right or to any third party intellectual property right. TI disclaims responsibility for, and you will fully indemnify TI and its representatives against, any claims, damages, costs, losses, and liabilities arising out of your use of these resources.

TI's products are provided subject to TI's Terms of Sale (www.ti.com/legal/termsofsale.html) or other applicable terms available either on ti.com or provided in conjunction with such TI products. TI's provision of these resources does not expand or otherwise alter TI's applicable warranties or warranty disclaimers for TI products.

Mailing Address: Texas Instruments, Post Office Box 655303, Dallas, Texas 75265
Copyright © 2019, Texas Instruments Incorporated