

UCC21530 4-A, 6-A, 5.7-kV_{RMS} Isolated Dual-Channel Gate Driver with 3.3-mm Channel-to-Channel Spacing

1 Features

- Universal: Dual Low-Side, Dual High-Side or Half-Bridge Driver
- Wide Body SOIC-14 (DWK) Package
- 3.3mm spacing between driver channels
- Switching Parameters:
 - 19-ns Typical Propagation Delay
 - 10-ns Minimum Pulse Width
 - 5-ns Maximum Delay Matching
 - 5-ns Maximum Pulse-Width Distortion
- Common-Mode Transient Immunity (CMTI) Greater than 100 V/ns
- Surge Immunity up to 12.8 kV
- Isolation Barrier Life >40 Years
- 4-A Peak Source, 6-A Peak Sink Output
- TTL and CMOS Compatible Inputs
- 3-V to 18-V Input VCCI Range
- Up to 25-V VDD Output Drive Supply
- Programmable Overlap and Dead Time
- Rejects Input Pulses and Noise Transients Shorter than 5 ns
- Operating Temperature Range –40 to +125°C
- Safety-Related Certifications (Planned):
 - 8000-V_{PK} Isolation per DIN V VDE V 0884-1 :2017-01
 - 5.7-kV_{RMS} Isolation for 1 Minute per UL 1577
 - CSA Certification per IEC 60950-1, IEC 62368-1, IEC 61010-1 and IEC 60601-1 End Equipment Standards
 - CQC Certification per GB4943.1-2011

2 Applications

- Solar String and Central Inverters
- AC-to-DC and DC-to-DC Charging Piles
- AC Inverter and Servo Drive
- AC-to-DC and DC-to-DC Power Delivery
- Energy Storage Systems

3 Description

The UCC21530 is an isolated dual-channel gate driver with 4-A source and 6-A sink peak current. It is designed to drive IGBTs and SiC MOSFETs up to 5-MHz with best-in-class propagation delay and pulse-width distortion.

The input side is isolated from the two output drivers by a 5.7-kV_{RMS} reinforced isolation barrier, with a minimum of 100-V/ns common-mode transient immunity (CMTI). Internal functional isolation between the two secondary-side drivers allows a working voltage of up to 1850 V_{MAX}.

This driver can be configured as two low-side drivers, two high-side drivers, or a half-bridge driver with programmable dead time (DT). The EN pin pulled low shuts down both outputs simultaneously and allows for normal operation when left open or pulled high. As a fail-safe measure, primary-side logic failures force both outputs low.

The device accepts VDD supply voltages up to 25 V. A wide input VCCI range from 3 V to 18 V makes the driver suitable for interfacing with both analog and digital controllers. All the supply voltage pins have under voltage lock-out (UVLO) protection.

With all these advanced features, the UCC21530 enables high efficiency, high power density, and robustness in a wide variety of power applications.

Device Information⁽¹⁾

PART NUMBER	PACKAGE	BODY SIZE (NOM)
UCC21530	DWK SOIC (14)	10.30 mm x 7.50 mm

(1) For all available packages, see the orderable addendum at the end of the data sheet.

Functional Block Diagram

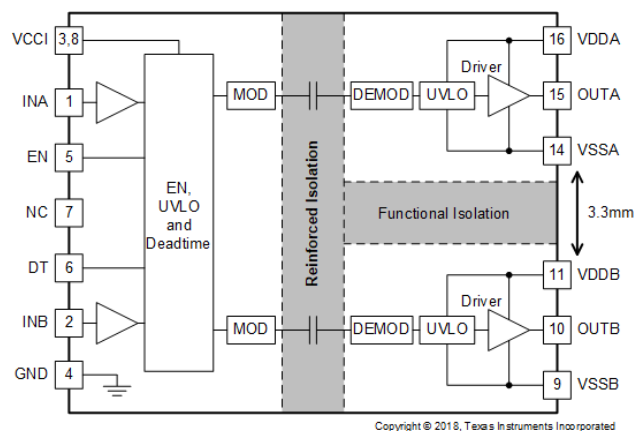

Copyright © 2018, Texas Instruments Incorporated



Table of Contents

1 Features	1	7.6 CMTI Testing.....	17
2 Applications	1	8 Detailed Description	18
3 Description	1	8.1 Overview	18
4 Revision History	2	8.2 Functional Block Diagram	18
5 Pin Configuration and Functions	3	8.3 Feature Description.....	19
6 Specifications	4	8.4 Device Functional Modes.....	22
6.1 Absolute Maximum Ratings	4	9 Application and Implementation	24
6.2 ESD Ratings.....	4	9.1 Application Information.....	24
6.3 Recommended Operating Conditions.....	4	9.2 Typical Application	24
6.4 Thermal Information	5	10 Power Supply Recommendations	34
6.5 Power Ratings.....	5	11 Layout	35
6.6 Insulation Specifications.....	6	11.1 Layout Guidelines	35
6.7 Safety-Related Certifications.....	7	11.2 Layout Example	36
6.8 Safety-Limiting Values	7	12 Device and Documentation Support	38
6.9 Electrical Characteristics.....	8	12.1 Documentation Support	38
6.10 Switching Characteristics	9	12.2 Related Links	38
6.11 Insulation Characteristics Curves	10	12.3 Receiving Notification of Documentation Updates	38
6.12 Typical Characteristics	11	12.4 Community Resources.....	38
7 Parameter Measurement Information	15	12.5 Trademarks	38
7.1 Propagation Delay and Pulse Width Distortion	15	12.6 Electrostatic Discharge Caution.....	38
7.2 Rising and Falling Time	15	12.7 Glossary	38
7.3 Input and Enable Response Time.....	15	13 Mechanical, Packaging, and Orderable	38
7.4 Programable Dead Time	16	Information	38
7.5 Power-Up UVLO Delay to OUTPUT	16	13.1 Package Option Addendum	39

4 Revision History

NOTE: Page numbers for previous revisions may differ from page numbers in the current version.

DATE	REVISION	NOTES
November 2018	*	Advance Information release.

5 Pin Configuration and Functions

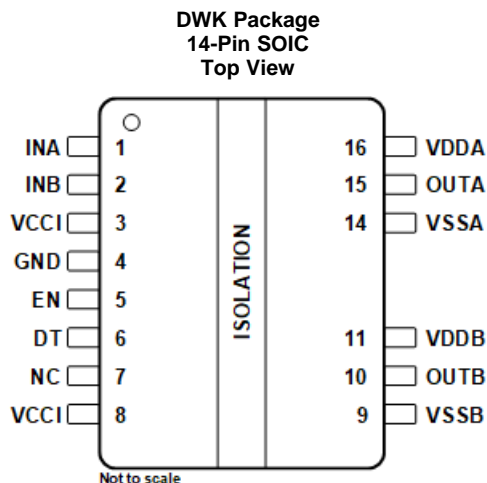

Pin Functions

PIN		I/O ⁽¹⁾	DESCRIPTION
NAME	NO.		
DT	6	I	DT pin configuration: <ul style="list-style-type: none"> Tying DT to VCCI disables the DT feature and allows the outputs to overlap. Placing a resistor (R_{DT}) between DT and GND adjusts dead time according to the equation: DT (in ns) = $10 \times R_{DT}$ (in kΩ). TI recommends bypassing this pin with a ceramic capacitor, 2.2 nF or greater, close to DT pin to achieve better noise immunity.
EN	5	I	Enable both driver outputs if asserted high, disable the output if set low. It is recommended to tie this pin to VCCI if not used to achieve better noise immunity. Bypass using a ≈ 1 -nF low ESR/ESL capacitor close to EN pin when connecting to a μ C with distance.
GND	4	P	Primary-side ground reference. All signals in the primary side are referenced to this ground.
INA	1	I	Input signal for A channel. INA input has a TTL/CMOS compatible input threshold. This pin is pulled low internally if left open. It is recommended to tie this pin to ground if not used to achieve better noise immunity.
INB	2	I	Input signal for B channel. INB input has a TTL/CMOS compatible input threshold. This pin is pulled low internally if left open. It is recommended to tie this pin to ground if not used to achieve better noise immunity.
NC	7	–	No internal connection.
OUTA	15	O	Output of driver A. Connect to the gate of the A channel FET or IGBT.
OUTB	10	O	Output of driver B. Connect to the gate of the B channel FET or IGBT.
VCCI	3	P	Primary-side supply voltage. Locally decoupled to GND using a low ESR/ESL capacitor located as close to the device as possible.
VCCI	8	P	Primary-side supply voltage. This pin is internally shorted to pin 3.
VDDA	16	P	Secondary-side power for driver A. Locally decoupled to VSSA using a low ESR/ESL capacitor located as close to the device as possible.
Vddb	11	P	Secondary-side power for driver B. Locally decoupled to VSSB using low ESR/ESL capacitor located as close to the device as possible.
VSSA	14	P	Ground for secondary-side driver A. Ground reference for secondary side A channel.
VSSB	9	P	Ground for secondary-side driver B. Ground reference for secondary side B channel.

(1) P =Power, I= Input, O= Output

ADVANCE INFORMATION

6 Specifications

6.1 Absolute Maximum Ratings

Over operating free-air temperature range (unless otherwise noted)⁽¹⁾

		MIN	MAX	UNIT
Input bias pin supply voltage	VCCI to GND	-0.5	20	V
Driver bias supply	VDDA-VSSA, VDDB-VSSB	-0.5	30	V
Output signal voltage	OUTA to VSSA, OUTB to VSSB	-0.5	V _{VDDA} +0.5, V _{VDDB} +0.5	V
	OUTA to VSSA, OUTB to VSSB, Transient for 200 ns	-2	V _{VDDA} +0.5, V _{VDDB} +0.5	V
Input signal voltage	INA, INB, EN, DT to GND	-0.5	V _{VCCI} +0.5	V
	INA, INB Transient for 200ns	-2	V _{VCCI} +0.5	V
Channel to channel internal isolation voltage	VSSA-VSSB		1850	V
Junction temperature, T _J ⁽²⁾		-40	150	°C
Storage temperature, T _{stg}		-65	150	°C

- (1) Stresses beyond those listed under *Absolute Maximum Ratings* may cause permanent damage to the device. These are stress ratings only, which do not imply functional operation of the device at these or any other conditions beyond those indicated under *Recommended Operating Conditions*. Exposure to absolute-maximum-rated conditions for extended periods may affect device reliability.
- (2) To maintain the recommended operating conditions for T_J, see the [Thermal Information](#).

6.2 ESD Ratings

		VALUE	UNIT
V _(ESD) Electrostatic discharge	Human-body model (HBM), per ANSI/ESDA/JEDEC JS-001 ⁽¹⁾	±4000	V
	Charged-device model (CDM), per JEDEC specification JESD22-C101 ⁽²⁾	±1500	

- (1) JEDEC document JEP155 states that 500-V HBM allows safe manufacturing with a standard ESD control process.
- (2) JEDEC document JEP157 states that 250-V CDM allows safe manufacturing with a standard ESD control process.

6.3 Recommended Operating Conditions

Over operating free-air temperature range (unless otherwise noted)

		MIN	MAX	UNIT
VCCI	VCCI Input supply voltage	3	18	V
VDDA-VSSA, VDDB-VSSB	Driver output bias supply refer to Vss	14.7	25	V
T _A	Ambient Temperature	-40	125	°C
T _J	Junction Temperature	-40	130	°C

6.4 Thermal Information

THERMAL METRIC ⁽¹⁾		UCC21530	UNIT
		DWK-14 (SOIC)	
$R_{\theta JA}$	Junction-to-ambient thermal resistance	68.3	°C/W
$R_{\theta JC(top)}$	Junction-to-case (top) thermal resistance	31.7	°C/W
$R_{\theta JB}$	Junction-to-board thermal resistance	27.6	°C/W
Ψ_{JT}	Junction-to-top characterization parameter	17.7	°C/W
Ψ_{JB}	Junction-to-board characterization parameter	27	°C/W

(1) For more information about traditional and new thermal metrics, see the [Semiconductor and IC Package Thermal Metrics](#) application report.

6.5 Power Ratings

		VALUE	UNIT
P_D	Power dissipation by UCC21530	1810	mW
P_{DI}	Power dissipation by transmitter side of UCC21530	50	mW
P_{DA}, P_{DB}	Power dissipation by each driver side of UCC21530	880	mW

V_{CCI} = 18 V, V_{DDA/B} = 15 V, I_{NA/B} = 3.3 V, 3.9 MHz 50% duty cycle square wave 1-nF load

6.6 Insulation Specifications

PARAMETER	TEST CONDITIONS	VALUE	UNIT
CLR	External clearance ⁽¹⁾	Shortest pin-to-pin distance through air	> 8 mm
CPG	External creepage ⁽¹⁾	Shortest pin-to-pin distance across the package surface	> 8 mm
DTI	Distance through insulation	Minimum internal gap (internal clearance) of the double insulation (2 × 10.5 μm)	>21 μm
CTI	Comparative tracking index	DIN EN 60112 (VDE 0303-11); IEC 60112	> 600 V
	Material group	According to IEC 60664-1	I
	Overvoltage category per IEC 60664-1	Rated mains voltage ≤ 600 V _{RMS}	I-IV
		Rated mains voltage ≤ 1000 V _{RMS}	I-III
DIN V VDE V 0884-11 (VDE V 0884-11): 2017-01⁽²⁾			
V _{IORM}	Maximum repetitive peak isolation voltage	AC voltage (bipolar)	2121 V _{PK}
V _{IOWM}	Maximum working isolation voltage	AC voltage (sine wave); time dependent dielectric breakdown (TDDB), test (See Figure 1)	1500 V _{RMS}
		DC voltage	2121 V _{DC}
V _{IOTM}	Maximum transient isolation voltage	V _{TEST} = V _{IOTM} , t = 60 sec (qualification) V _{TEST} = 1.2 × V _{IOTM} , t = 1 s (100% production)	8000 V _{PK}
V _{IOSM}	Maximum surge isolation voltage ⁽³⁾	Test method per IEC 62368-1, 1.2/50 μs waveform, V _{TEST} = 1.6 × V _{IOSM} = 12800 V _{PK} (qualification)	8000 V _{PK}
q _{pd}	Apparent charge ⁽⁴⁾	Method a, After Input/Output safety test subgroup 2/3. V _{ini} = V _{IOTM} , t _{ini} = 60s; V _{pd(m)} = 1.2 × V _{IORM} = 2545 V _{PK} , t _m = 10s	<5 pC
		Method a, After environmental tests subgroup 1. V _{ini} = V _{IOTM} , t _{ini} = 60s; V _{pd(m)} = 1.6 × V _{IORM} = 3394 V _{PK} , t _m = 10s	<5 pC
		Method b1; At routine test (100% production) and preconditioning (type test) V _{ini} = 1.2 × V _{IOTM} ; t _{ini} = 1s; V _{pd(m)} = 1.875 × V _{IORM} = 3977 V _{PK} , t _m = 1s	<5 pC
C _{IO}	Barrier capacitance, input to output ⁽⁵⁾	V _{IO} = 0.4 sin (2πft), f = 1 MHz	1.2 pF
R _{IO}	Isolation resistance, input to output ⁽⁵⁾	V _{IO} = 500 V at T _A = 25°C	> 10 ¹² Ω
		V _{IO} = 500 V at 100°C ≤ T _A ≤ 125°C	> 10 ¹¹ Ω
		V _{IO} = 500 V at T _S = 150°C	> 10 ⁹ Ω
	Pollution degree		2
	Climatic category		40/125/21
UL 1577			
V _{ISO}	Withstand isolation voltage	V _{TEST} = V _{ISO} = 5700 V _{RMS} , t = 60 sec. (qualification), V _{TEST} = 1.2 × V _{ISO} = 6840V _{RMS} , t = 1 sec (100% production)	5700 V _{RMS}

- (1) Creepage and clearance requirements should be applied according to the specific equipment isolation standards of an application. Care should be taken to maintain the creepage and clearance distance of a board design to ensure that the mounting pads of the isolator on the printed-circuit board do not reduce this distance. Creepage and clearance on a printed-circuit board become equal in certain cases. Techniques such as inserting grooves and/or ribs on a printed circuit board are used to help increase these specifications.
- (2) This coupler is suitable for safe electrical insulation only within the safety ratings. Compliance with the safety ratings shall be ensured by means of suitable protective circuits.
- (3) Testing is carried out in air or oil to determine the intrinsic surge immunity of the isolation barrier.
- (4) Apparent charge is electrical discharge caused by a partial discharge (pd).
- (5) All pins on each side of the barrier tied together creating a two-pin device.

6.7 Safety-Related Certifications

VDE	CSA	UL	CQC
Plan to certify according to DIN V VDE V 0884-11:2017-01 and DIN EN 61010-1 (VDE 0411-1):2011-07	Plan to certify according to IEC 60950-1, IEC 62368-1, IEC 61010-1 and IEC 60601-1	Plan to be recognized under UL 1577 Component Recognition Program	Plan to certify according to GB 4943.1-2011

6.8 Safety-Limiting Values

Safety limiting intends to prevent potential damage to the isolation barrier upon failure of input or output circuitry. A failure of the I/O can allow low resistance to ground or the supply and, without current limiting, dissipate sufficient power to overheat the die and damage the isolation barrier potentially leading to secondary system failures.

PARAMETER	TEST CONDITIONS	SIDE	MIN	TYP	MAX	UNIT
I _S Safety output supply current	R _{θJA} = 68.3°C/W, VDDA/B = 15 V, T _A = 25°C, T _J = 150°C See Figure 2	DRIVER A, DRIVER B			58	mA
	R _{θJA} = 68.3°C/W, VDDA/B = 25 V, T _A = 25°C, T _J = 150°C See Figure 2	DRIVER A, DRIVER B			35	mA
P _S Safety supply power	R _{θJA} = 68.3°C/W, T _A = 25°C, T _J = 150°C See Figure 3	INPUT			50	mW
		DRIVER A			880	
		DRIVER B			880	
		TOTAL			1810	
T _S Safety temperature ⁽¹⁾					150	°C

- (1) The maximum safety temperature, T_S, has the same value as the maximum junction temperature, T_J, specified for the device. The I_S and P_S parameters represent the safety current and safety power respectively. The maximum limits of I_S and P_S should not be exceeded. These limits vary with the ambient temperature, T_A.

The junction-to-air thermal resistance, R_{θJA}, in the [Thermal Information](#) table is that of a device installed on a high-K test board for leaded surface-mount packages. Use these equations to calculate the value for each parameter:

$$T_J = T_A + R_{\theta JA} \times P, \text{ where } P \text{ is the power dissipated in the device.}$$

$$T_{J(max)} = T_S = T_A + R_{\theta JA} \times P_S, \text{ where } T_{J(max)} \text{ is the maximum allowed junction temperature.}$$

$$P_S = I_S \times V_I, \text{ where } V_I \text{ is the maximum input voltage.}$$

6.9 Electrical Characteristics

$V_{VCCI} = 3.3\text{ V}$ or 5 V , $0.1\text{-}\mu\text{F}$ capacitor from V_{CCI} to GND , $V_{VDDA} = V_{VDDB} = 15\text{ V}$, $1\text{-}\mu\text{F}$ capacitor from V_{DDA} and V_{DDB} to $VSSA$ and $VSSB$, DT pin tied to V_{CCI} , $C_L = 0\text{ pF}$, $T_A = -40^\circ\text{C}$ to $+125^\circ\text{C}$, (unless otherwise noted)

PARAMETER		TEST CONDITIONS	MIN	TYP	MAX	UNIT
SUPPLY CURRENTS						
I_{VCCI}	V_{CCI} quiescent current	$V_{INA} = 0\text{ V}$, $V_{INB} = 0\text{ V}$		1.5	2.0	mA
I_{VDDA} , I_{VDDB}	V_{DDA} and V_{DDB} quiescent current	$V_{INA} = 0\text{ V}$, $V_{INB} = 0\text{ V}$		1.0	1.8	mA
I_{VCCI}	V_{CCI} per operating current	($f = 500\text{ kHz}$) current per channel		2.0		mA
I_{VDDA} , I_{VDDB}	V_{DDA} and V_{DDB} operating current	($f = 500\text{ kHz}$) current per channel, $C_{OUT} = 100\text{ pF}$, V_{VDDA} , $V_{VDDB} = 15\text{ V}$		3.0		mA
VCCI TO GND UNDERVOLTAGE THRESHOLDS						
V_{VCCI_ON}	UVLO Rising threshold		2.55	2.7	2.85	V
V_{VCCI_OFF}	UVLO Falling threshold		2.35	2.5	2.65	V
V_{VCCI_HYS}	UVLO Threshold hysteresis			0.2		V
VDD TO VSS UNDERVOLTAGE THRESHOLDS						
V_{VDDA_ON} , V_{VDDB_ON}	UVLO Rising threshold		12.5	13.5	14.5	V
V_{VDDA_OFF} , V_{VDDB_OFF}	UVLO Falling threshold		11.5	12.5	13.5	V
V_{VDDA_HYS} , V_{VDDB_HYS}	UVLO Threshold hysteresis			1.0		V
INA and INB						
V_{INAH} , V_{INBH}	Input high threshold voltage		1.6	1.8	2	V
V_{INAL} , V_{INBL}	Input low threshold voltage		0.8	1	1.2	V
V_{INA_HYS} , V_{INB_HYS}	Input threshold hysteresis			0.8		V
V_{INA} , V_{INB}	Negative transient, ref to GND , 50 ns pulse	Not production tested, bench test only	-5			V
EN THRESHOLDS						
V_{ENH}	Enable high voltage		2.0			V
V_{ENL}	Enable low voltage				0.8	V

ADVANCE INFORMATION

Electrical Characteristics (continued)

$V_{VCCI} = 3.3\text{ V}$ or 5 V , $0.1\text{-}\mu\text{F}$ capacitor from VCCI to GND, $V_{VDDA} = V_{VDDB} = 15\text{ V}$, $1\text{-}\mu\text{F}$ capacitor from VDDA and VDDB to VSSA and VSSB, DT pin tied to VCCI, $C_L = 0\text{ pF}$, $T_A = -40^\circ\text{C}$ to $+125^\circ\text{C}$, (unless otherwise noted)

PARAMETER	TEST CONDITIONS	MIN	TYP	MAX	UNIT
OUTPUT					
I_{OA+}, I_{OB+}	Peak output source current	$C_{VDD} = 10\text{ }\mu\text{F}$, $C_{LOAD} = 0.18\text{ }\mu\text{F}$, $f = 1\text{ kHz}$, bench measurement	4		A
I_{OA-}, I_{OB-}	Peak output sink current	$C_{VDD} = 10\text{ }\mu\text{F}$, $C_{LOAD} = 0.18\text{ }\mu\text{F}$, $f = 1\text{ kHz}$, bench measurement	6		A
R_{OHA}, R_{OHB}	Output resistance at high state	$I_{OUT} = -10\text{ mA}$, $T_A = 25^\circ\text{C}$, R_{OHA} , R_{OHB} do not represent drive pull-up performance. See t_{RISE} in Switching Characteristics and Output Stage for details.	5		Ω
R_{OLA}, R_{OLB}	Output resistance at low state	$I_{OUT} = 10\text{ mA}$, $T_A = 25^\circ\text{C}$	0.55		Ω
V_{OHA}, V_{OHB}	Output voltage at high state	$V_{VDDA}, V_{VDDB} = 15\text{ V}$, $I_{OUT} = -10\text{ mA}$, $T_A = 25^\circ\text{C}$	14.95		V
V_{OLA}, V_{OLB}	Output voltage at low state	$V_{VDDA}, V_{VDDB} = 15\text{ V}$, $I_{OUT} = 10\text{ mA}$, $T_A = 25^\circ\text{C}$	5.5		mV
DEADTIME AND OVERLAP PROGRAMMING					
Dead time	DT pin tied to VCCI	Overlap determined by INA INB			-
	$R_{DT} = 20\text{ k}\Omega$	160	200	240	ns

6.10 Switching Characteristics

$V_{VCCI} = 3.3\text{ V}$ or 5 V , $0.1\text{-}\mu\text{F}$ capacitor from VCCI to GND, $V_{VDDA} = V_{VDDB} = 15\text{ V}$, $1\text{-}\mu\text{F}$ capacitor from VDDA and VDDB to VSSA and VSSB, $T_A = -40^\circ\text{C}$ to $+125^\circ\text{C}$, (unless otherwise noted).

PARAMETER	TEST CONDITIONS	MIN	TYP	MAX	UNIT	
t_{RISE}	Output rise time, 20% to 80% measured points	$C_{OUT} = 1.8\text{ nF}$	6	16	ns	
t_{FALL}	Output fall time, 90% to 10% measured points	$C_{OUT} = 1.8\text{ nF}$	7	12	ns	
t_{PWmin}	Minimum pulse width	Output off for less than minimum, $C_{OUT} = 0\text{ pF}$		20	ns	
t_{PDHL}	Propagation delay from INx to OUTx falling edges		14	19	30	ns
t_{PDLH}	Propagation delay from INx to OUTx rising edges		14	19	30	ns
t_{PWD}	Pulse width distortion $ t_{PDLH} - t_{PDHL} $			6	ns	
t_{DM}	Propagation delays matching between VOUTA, VOUTB	$f = 100\text{ kHz}$		5	ns	
$t_{VCCI+ \text{ to } OUT}$	VCCI Power-up Delay Time: UVLO Rise to OUTA, OUTB, See Figure 31	INA or INB tied to VCCI	40		μs	
$t_{VDD+ \text{ to } OUT}$	VDDA, VDDB Power-up Delay Time: UVLO Rise to OUTA, OUTB See Figure 32	INA or INB tied to VCCI	50			
$ CM_H $	High-level common-mode transient immunity (See CMTI Testing)	Slew rate of GND vs. VSSA/B, INA and INB both are tied to GND or VCCI; $V_{CM} = 1500\text{ V}$;	100		V/ns	
$ CM_L $	Low-level common-mode transient immunity (See CMTI Testing)	Slew rate of GND vs. VSSA/B, INA and INB both are tied to GND or VCCI; $V_{CM} = 1500\text{ V}$;	100			

6.11 Insulation Characteristics Curves

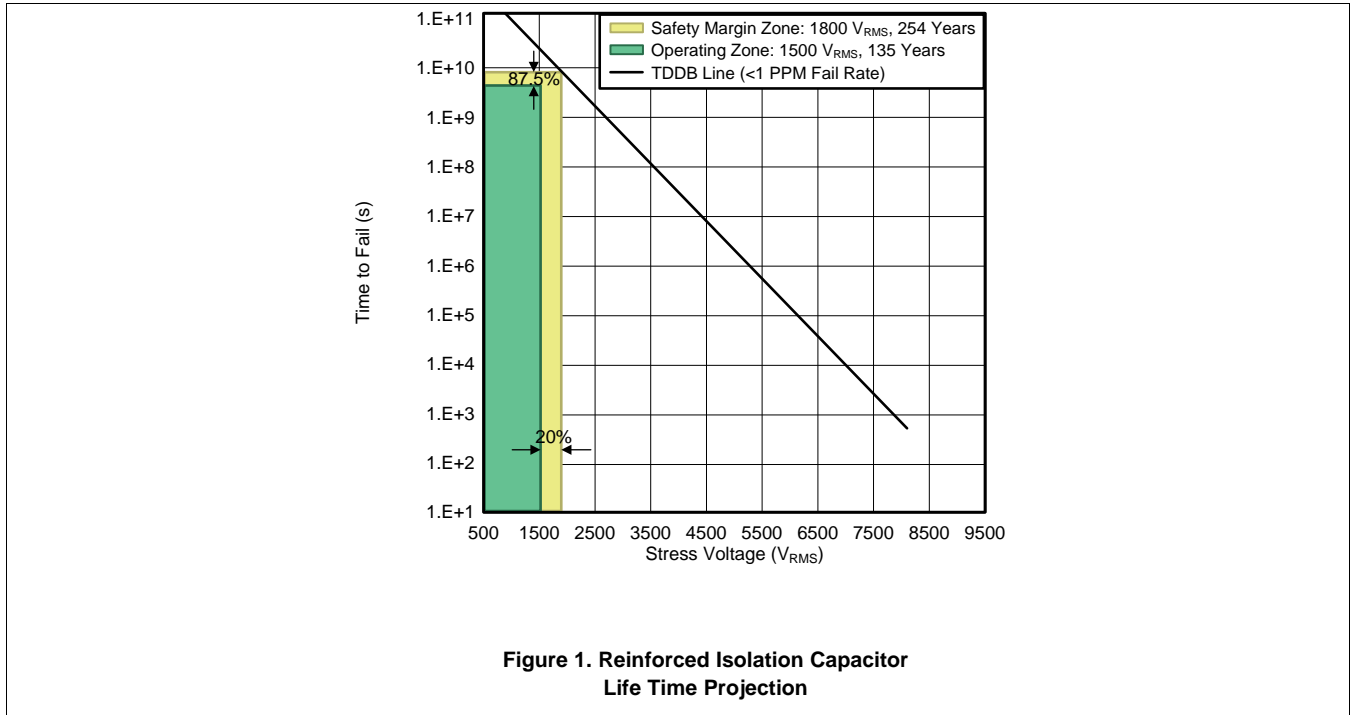

ADVANCE INFORMATION

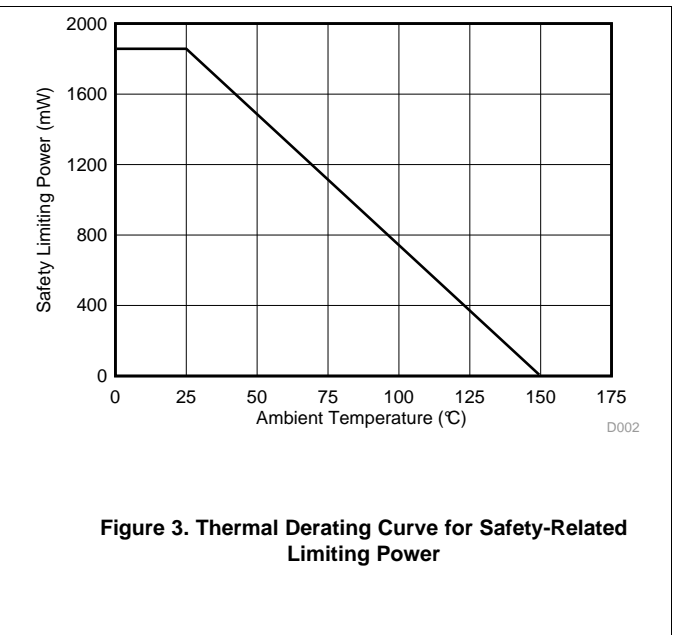
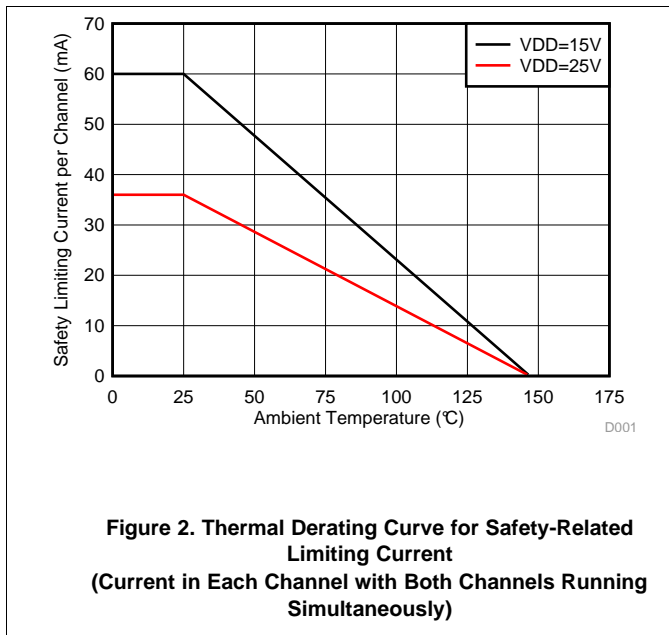

6.12 Typical Characteristics

VDDA = VDDB = 15 V, VCCI = 3.3 V, T_A = 25°C, No load. (unless otherwise noted)

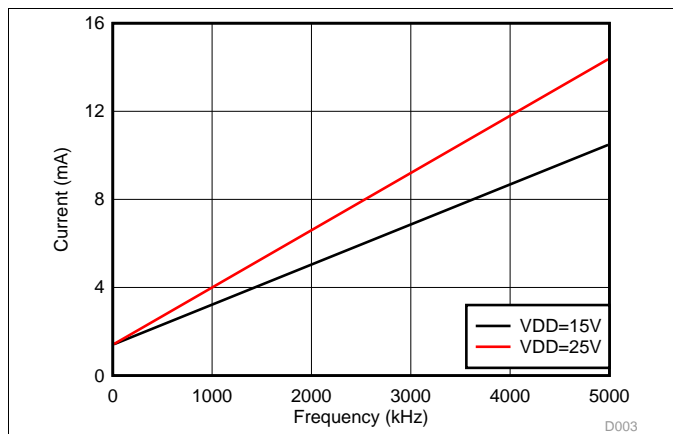

Figure 4. Per Channel Current Consumption vs. Frequency (No Load, VDD = 15 V or 25 V)

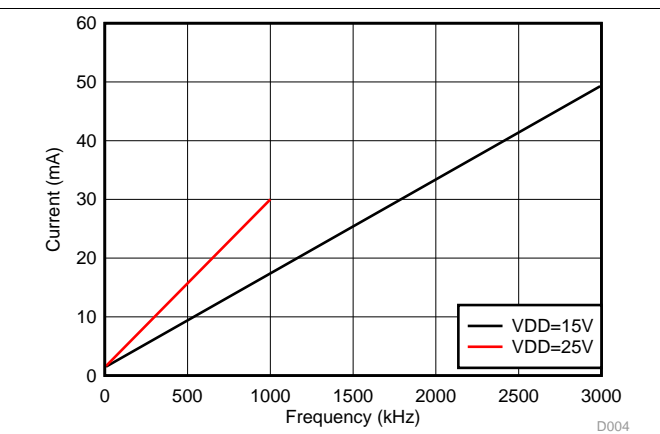

Figure 5. Per Channel Current Consumption ($I_{VDDA/B}$) vs. Frequency (1-nF Load, VDD = 15 V or 25 V)

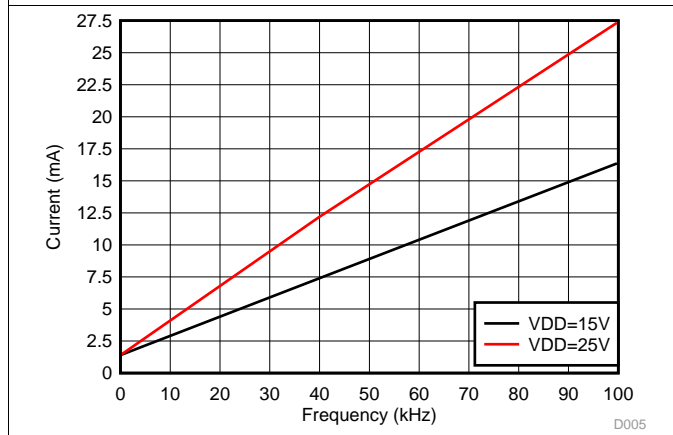

Figure 6. Per Channel Current Consumption ($I_{VDDA/B}$) vs. Frequency (10-nF Load, VDD = 15 V or 25 V)

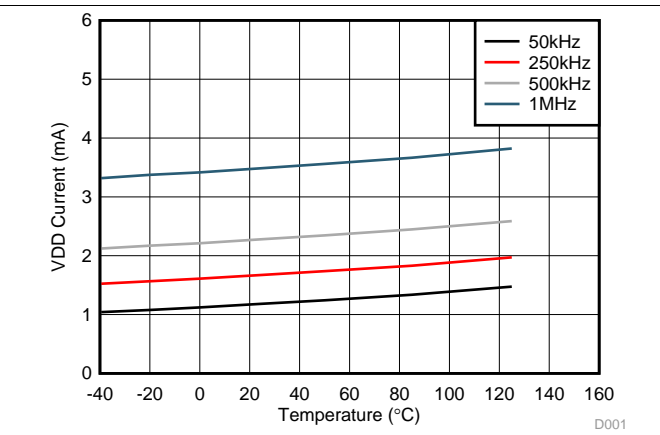

Figure 7. Per Channel ($I_{VDDA/B}$) Supply Current vs. Temperature (VDD=15V, No Load, Different Switching Frequencies)

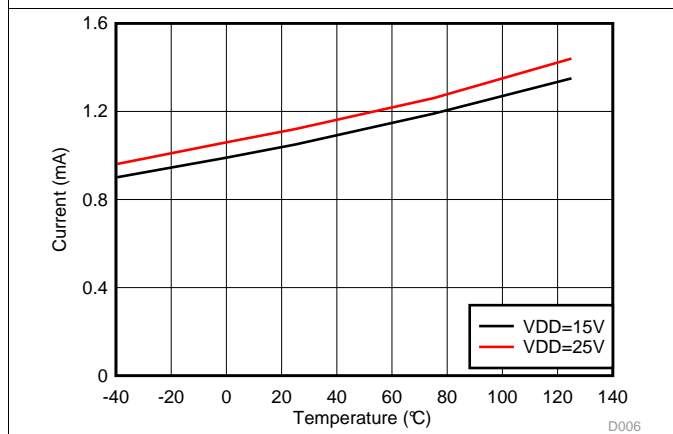

Figure 8. Per Channel ($I_{VDDA/B}$) Quiescent Supply Current vs Temperature (No Load, Input Low, No Switching)

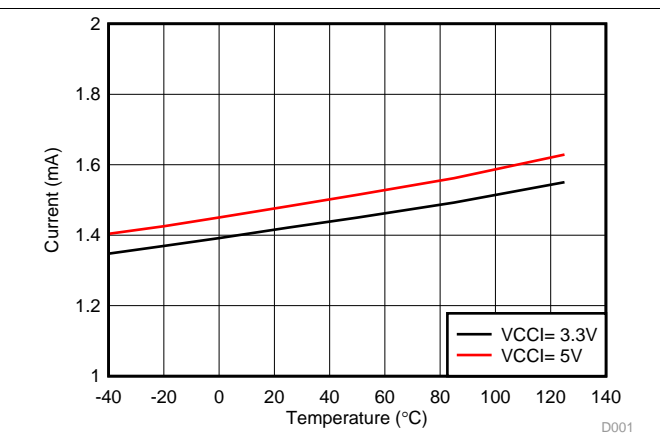

Figure 9. I_{VCCI} Quiescent Supply Current vs Temperature (No Load, Input Low, No Switching)

ADVANCE INFORMATION

Typical Characteristics (continued)

VDDA = VDDB = 15 V, VCCI = 3.3 V, T_A = 25°C, No load. (unless otherwise noted)

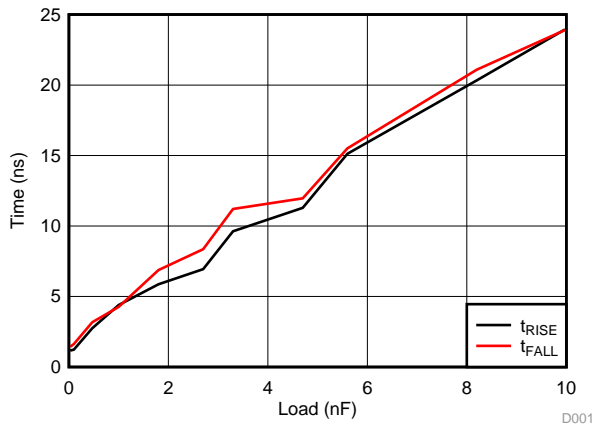

Figure 10. Rising and Falling Times vs. Load

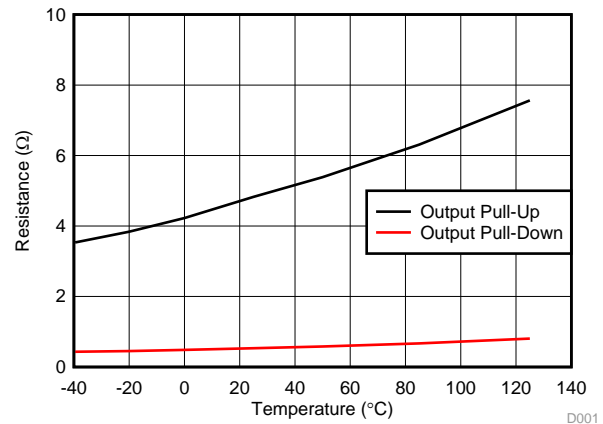

Figure 11. Output Resistance vs. Temperature

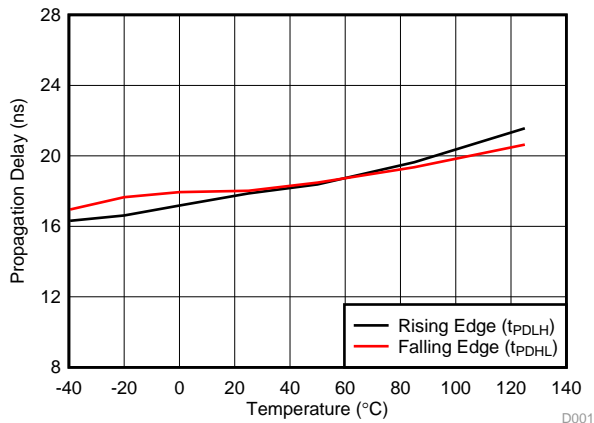

Figure 12. Propagation Delay vs. Temperature

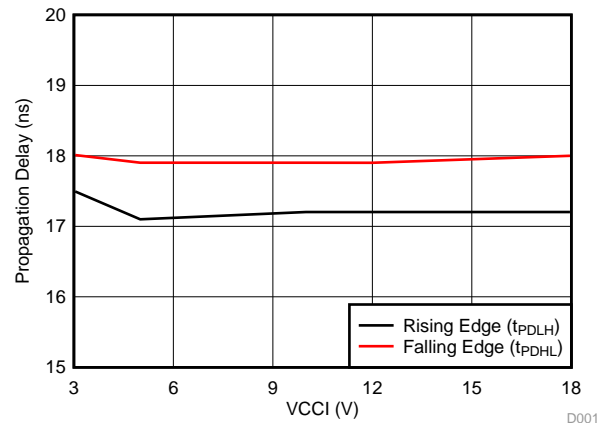

Figure 13. Propagation Delay vs. VCCI

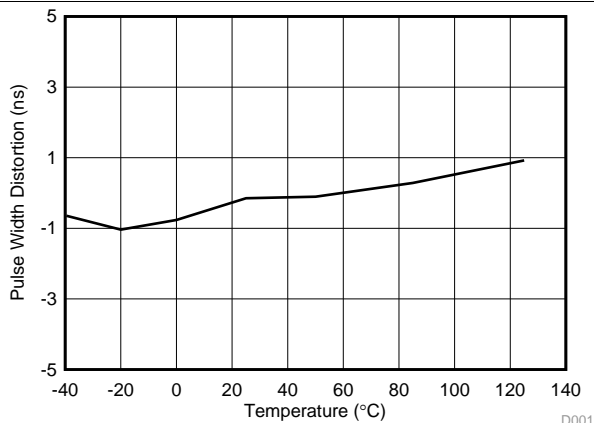

Figure 14. Pulse Width Distortion vs. Temperature

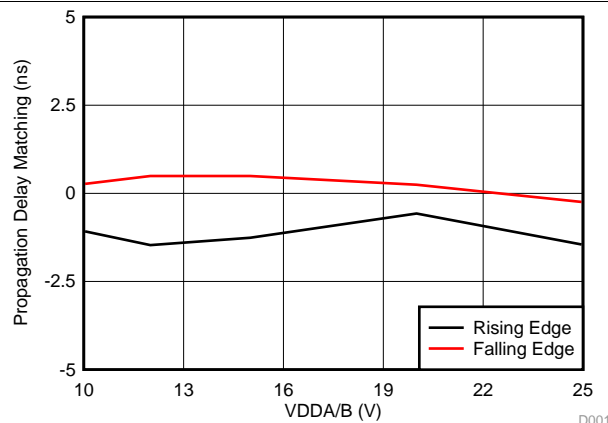
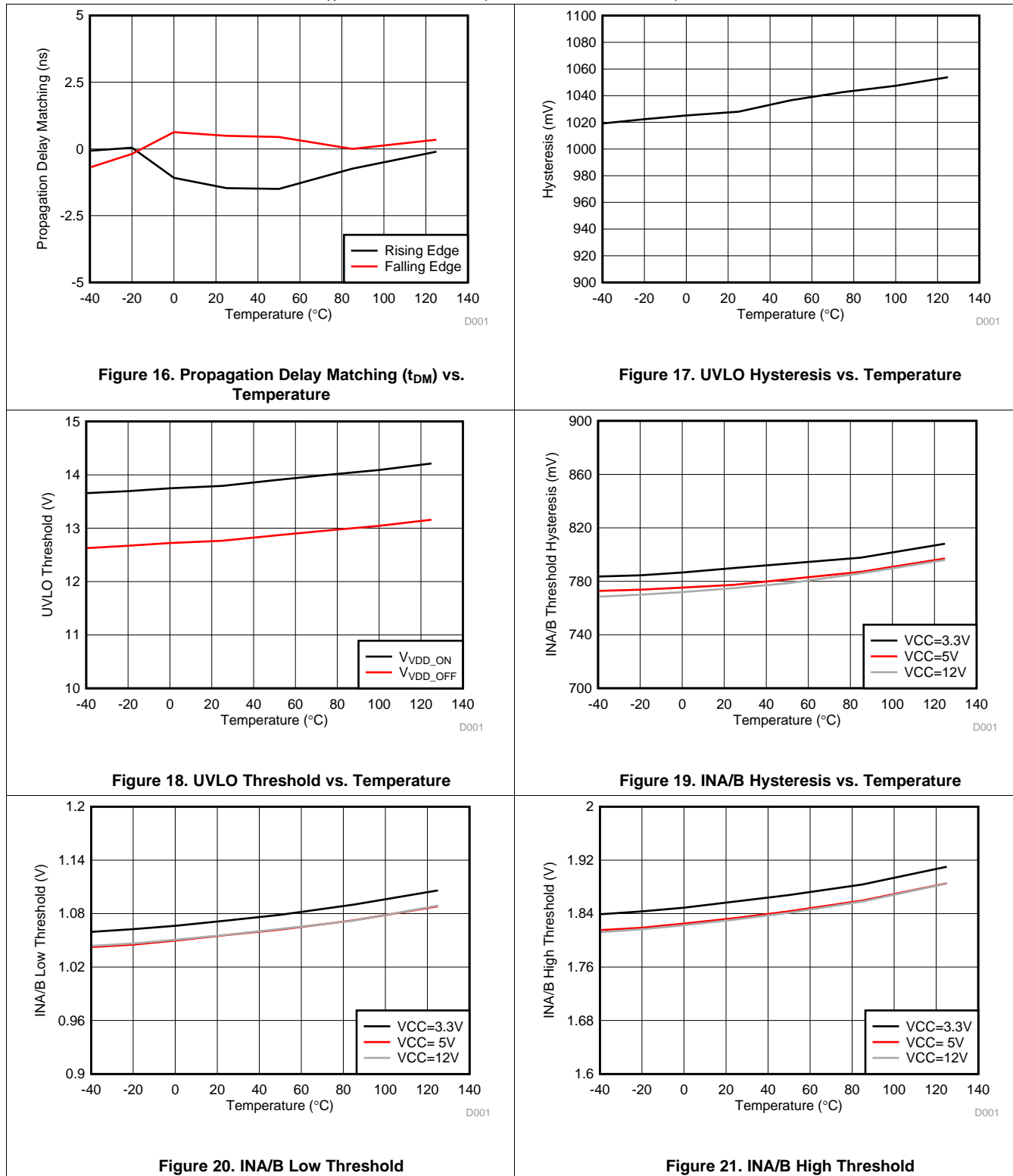

Figure 15. Propagation Delay Matching (t_{DM}) vs. VDD

ADVANCE INFORMATION

Typical Characteristics (continued)

VDDA = VDDB = 15 V, VCCI = 3.3 V, T_A = 25°C, No load. (unless otherwise noted)



ADVANCE INFORMATION

Typical Characteristics (continued)

VDDA = VDDB = 15 V, VCCI = 3.3 V, T_A = 25°C, No load. (unless otherwise noted)

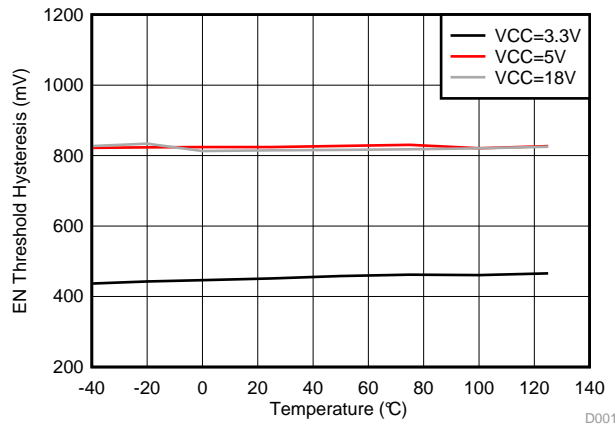

Figure 22. EN Threshold Hysteresis vs. Temperature

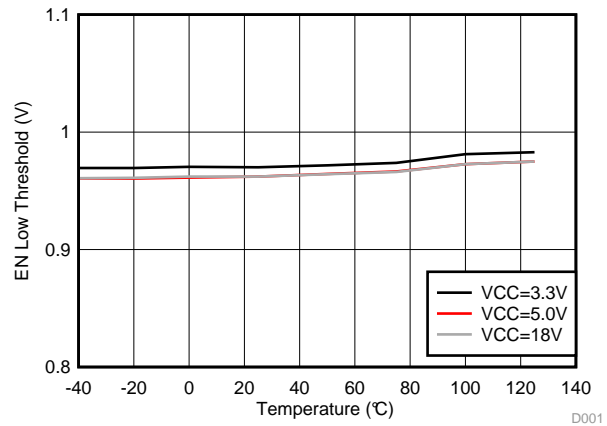

Figure 23. EN Low Threshold

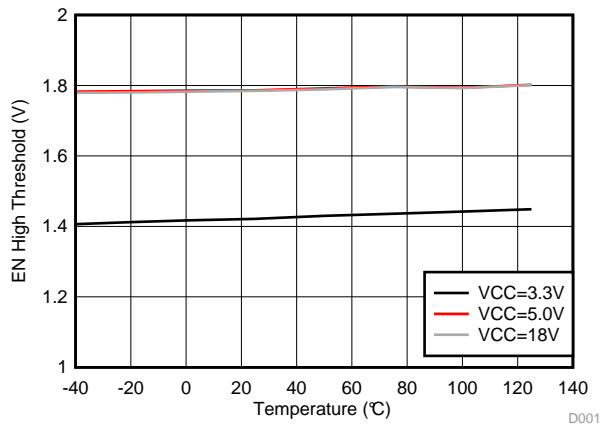

Figure 24. EN High Threshold

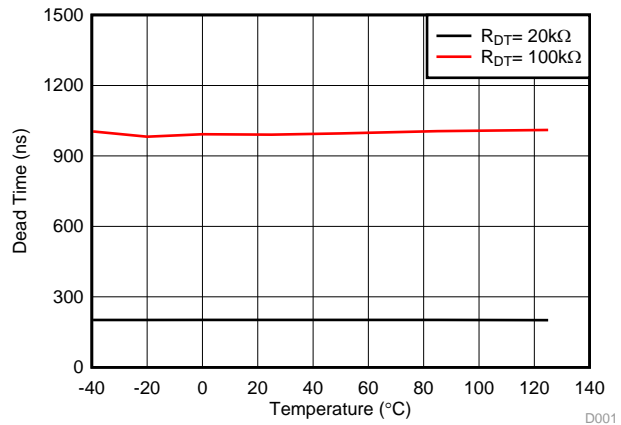

Figure 25. Dead Time vs. Temperature (with R_{DT} = 20 kΩ and 100 kΩ)

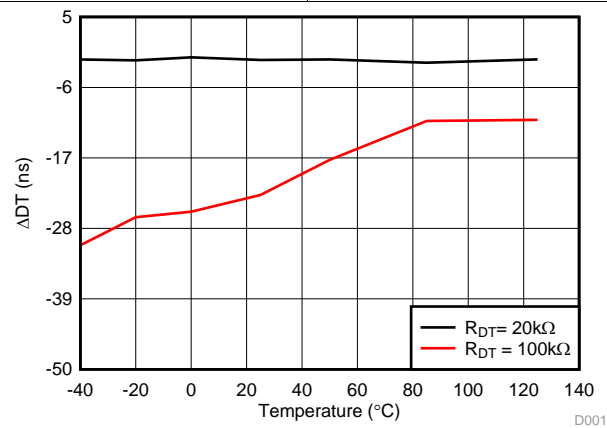

Figure 26. Dead Time Matching vs. Temperature (with R_{DT} = 20 kΩ and 100 kΩ)

7 Parameter Measurement Information

7.1 Propagation Delay and Pulse Width Distortion

Figure 27 shows how one calculates pulse width distortion (t_{PWD}) and delay matching (t_{DM}) from the propagation delays of channels A and B. It can be measured by ensuring that both inputs are in phase and disabling the dead time function by shorting the DT Pin to VCC.

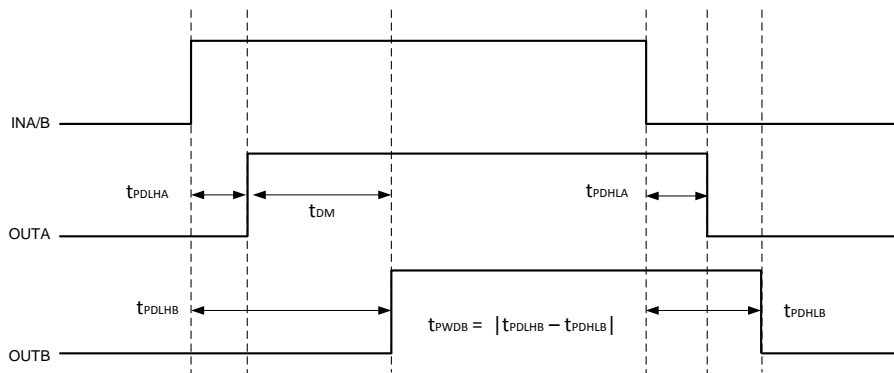

Figure 27. Overlapping Inputs, Dead Time Disabled

7.2 Rising and Falling Time

Figure 28 shows the criteria for measuring rising (t_{RISE}) and falling (t_{FALL}) times. For more information on how short rising and falling times are achieved see [Output Stage](#).

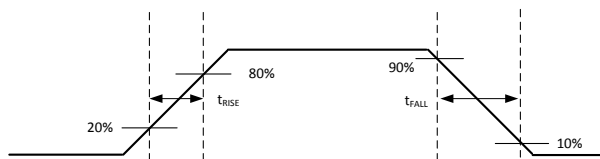

Figure 28. Rising and Falling Time Criteria

7.3 Input and Enable Response Time

Figure 29 shows the response time of the enable function. For more information, see [Enable Pin](#).

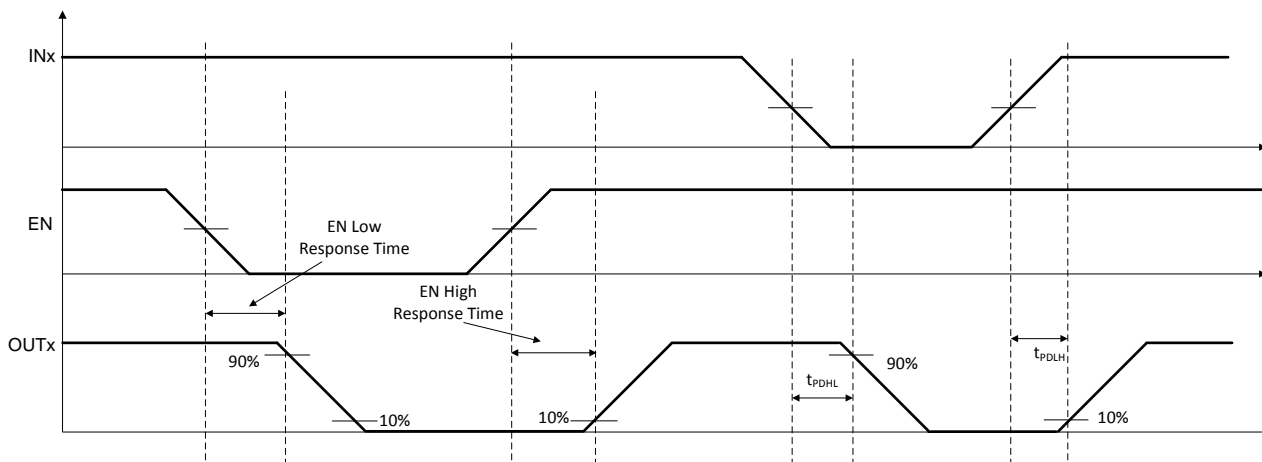

Figure 29. Enable Pin Timing

ADVANCE INFORMATION

7.4 Programmable Dead Time

Tying DT to VCCI disables DT feature and allows the outputs to overlap. Placing a resistor (R_{DT}) between DT pin and GND can adjust the dead time. For more details on dead time, refer to [Programmable Dead Time \(DT\) Pin](#).

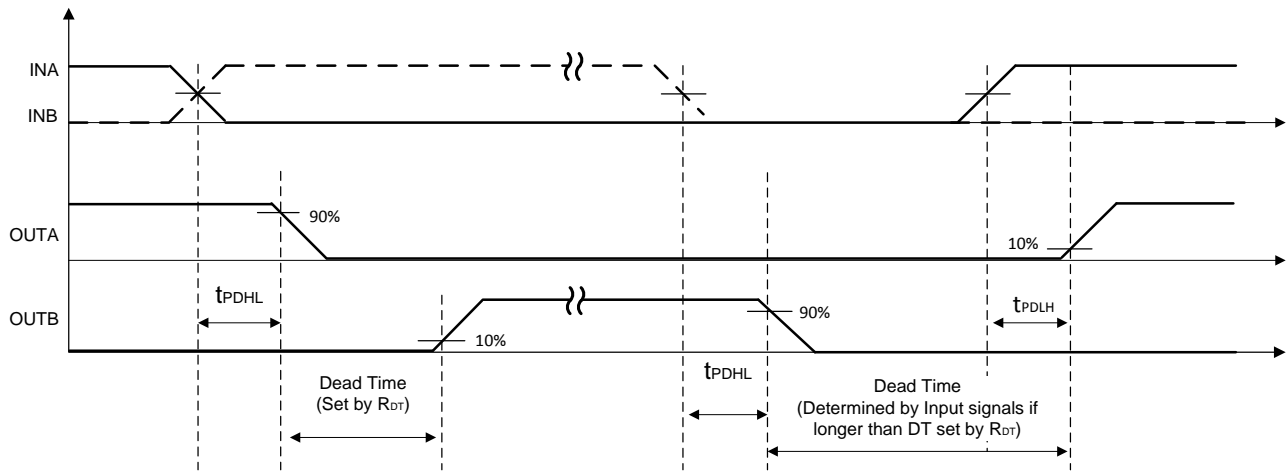

Figure 30. Dead-Time Switching Parameters

7.5 Power-Up UVLO Delay to OUTPUT

Whenever the supply voltage VCCI crosses from below the falling threshold V_{VCCI_OFF} to above the rising threshold V_{VCCI_ON} , and whenever the supply voltage VDDx crosses from below the falling threshold V_{VDDx_OFF} to above the rising threshold V_{VDDx_ON} , there is a delay before the outputs begin responding to the inputs. For VCCI UVLO this delay is defined as $t_{VCCI+ to OUT}$, and is typically 40 μs . For VDDx UVLO this delay is defined as $t_{VDD+ to OUT}$, and is typically 50 μs . TI recommends allowing some margin before driving input signals, to ensure the driver VCCI and VDD bias supplies are fully activated. [Figure 31](#) and [Figure 32](#) show the power-up UVLO delay timing diagram for VCCI and VDD.

Whenever the supply voltage VCCI crosses below the falling threshold V_{VCCI_OFF} , or VDDx crosses below the falling threshold V_{VDDx_OFF} , the outputs stop responding to the inputs and are held low within 1 μs . This asymmetric delay is designed to ensure safe operation during VCCI or VDDx brownouts..

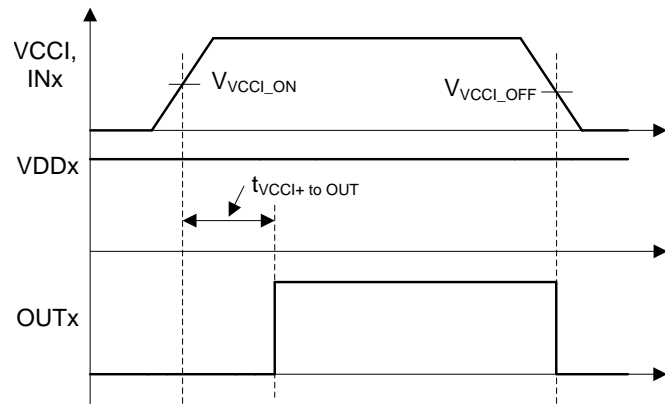

Figure 31. VCCI Power-Up UVLO Delay

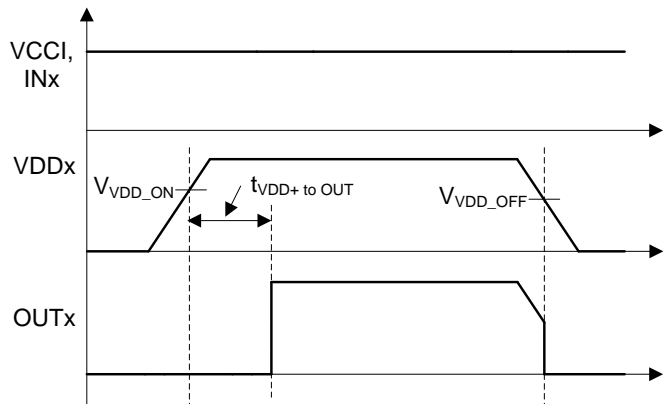

Figure 32. VDDA/B Power-Up UVLO Delay

7.6 CMTI Testing

Figure 33 is a simplified diagram of the CMTI testing configuration.

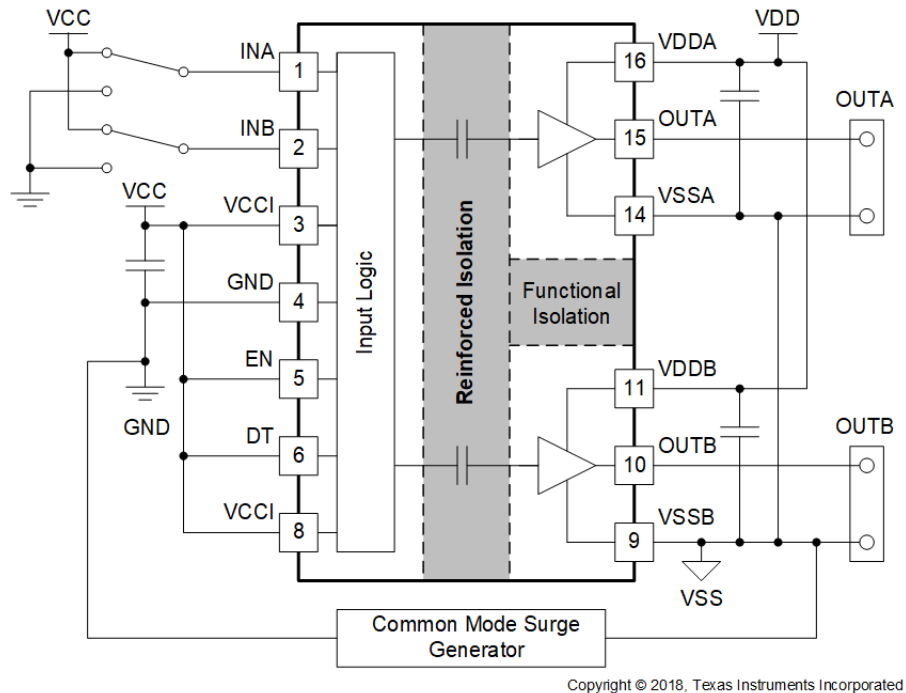

Figure 33. Simplified CMTI Testing Setup

8 Detailed Description

8.1 Overview

In order to switch power transistors rapidly and reduce switching power losses, high-current gate drivers are often placed between the output of control devices and the gates of power transistors. There are several instances where controllers are not capable of delivering sufficient current to drive the gates of power transistors. This is especially the case with digital controllers, since the input signal from the digital controller is often a 3.3-V logic signal capable of only delivering a few mA.

The UCC21530 is a flexible dual gate driver which can be configured to fit a variety of power supply and motor drive topologies, as well as drive several types of transistors, including SiC MOSFETs. UCC21530 has many features that allow it to integrate well with control circuitry and protect the gates it drives such as: resistor-programmable dead time (DT) control, an EN pin, and under voltage lock out (UVLO) for both input and output voltages. The UCC21530 also holds its outputs low when the inputs are left open or when the input pulse is not wide enough. The driver inputs are CMOS and TTL compatible for interfacing to digital and analog power controllers alike. Each channel is controlled by its respective input pins (INA and INB), allowing full and independent control of each of the outputs.

8.2 Functional Block Diagram

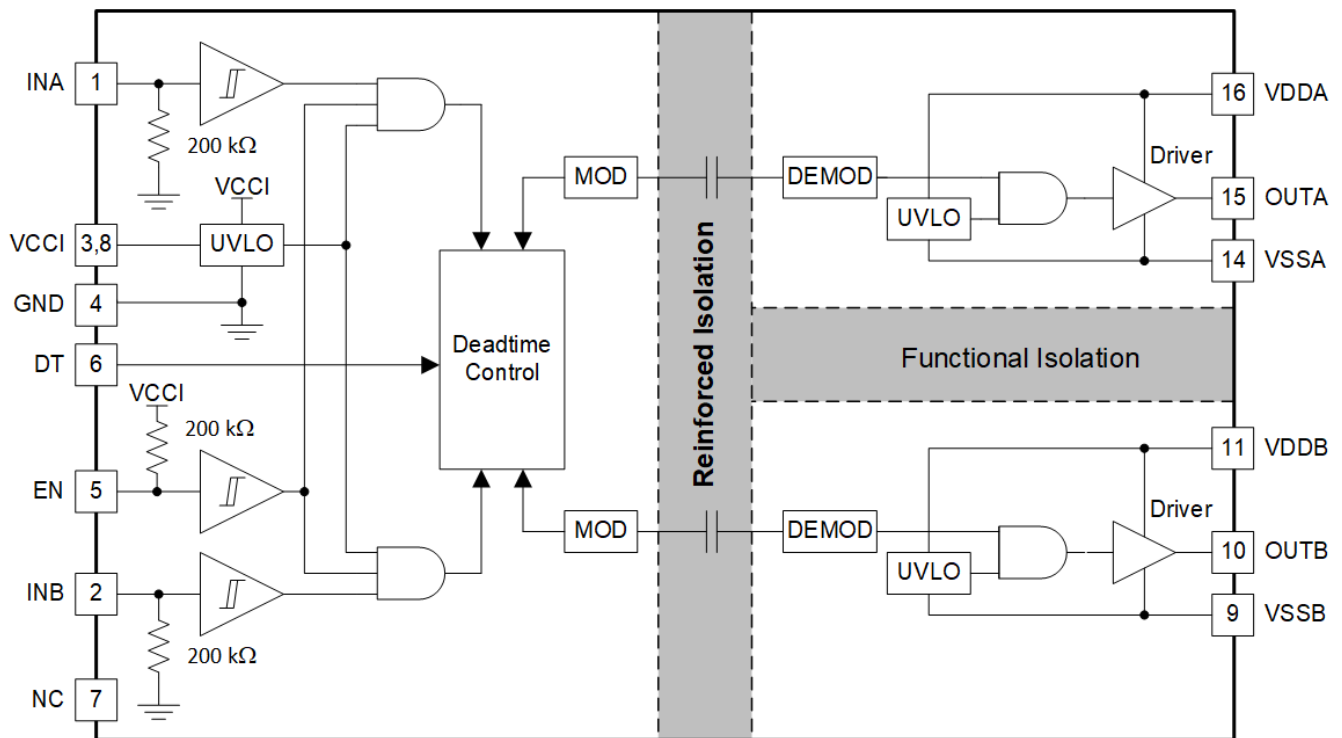

Copyright © 2018, Texas Instruments Incorporated

ADVANCE INFORMATION

8.3 Feature Description

8.3.1 VDD, VCCI, and Under Voltage Lock Out (UVLO)

The UCC21530 has an internal under voltage lock out (UVLO) protection feature on the supply circuit blocks between the VDD and VSS pins for both outputs. When the VDD bias voltage is lower than V_{VDD_ON} at device start-up or lower than V_{VDD_OFF} after start-up, the VDD UVLO feature holds the effected output low, regardless of the status of the input pins (INA and INB).

When the output stages of the driver are in an unbiased or UVLO condition, the driver outputs are held low by an active clamp circuit that limits the voltage rise on the driver outputs (Illustrated in [Figure 34](#)). In this condition, the upper PMOS is resistively held off by R_{HI-Z} while the lower NMOS gate is tied to the driver output through R_{CLAMP} . In this configuration, the output is effectively clamped to the threshold voltage of the lower NMOS device, typically less than 1.5V, when no bias power is available.

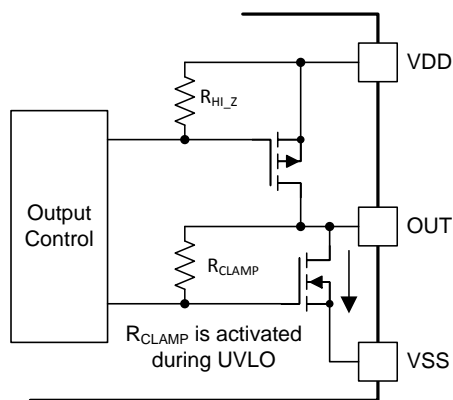

Figure 34. Simplified Representation of Active Pull Down Feature

The VDD UVLO protection has a hysteresis feature (V_{VDD_HYS}). This hysteresis prevents chatter when there is ground noise from the power supply. Also this allows the device to accept small drops in bias voltage, which is bound to happen when the device starts switching and operating current consumption increases suddenly.

The input side of the UCC21530 also has an internal under voltage lock out (UVLO) protection feature. The device isn't active unless the voltage, VCCI, is going to exceed V_{VCCI_ON} on start up. And a signal will cease to be delivered when that pin receives a voltage less than V_{VCCI_OFF} . And, just like the UVLO for VDD, there is hysteresis (V_{VCCI_HYS}) to ensure stable operation.

UCC21530 can withstand an absolute maximum of 30 V for VDD, and 20 V for VCCI.

Table 1. UCC21530 VCCI UVLO Feature Logic

CONDITION	INPUTS		OUTPUTS	
	INA	INB	OUTA	OUTB
$V_{CCI-GND} < V_{VCCI_ON}$ during device start up	H	L	L	L
$V_{CCI-GND} < V_{VCCI_ON}$ during device start up	L	H	L	L
$V_{CCI-GND} < V_{VCCI_ON}$ during device start up	H	H	L	L
$V_{CCI-GND} < V_{VCCI_ON}$ during device start up	L	L	L	L
$V_{CCI-GND} < V_{VCCI_OFF}$ after device start up	H	L	L	L
$V_{CCI-GND} < V_{VCCI_OFF}$ after device start up	L	H	L	L
$V_{CCI-GND} < V_{VCCI_OFF}$ after device start up	H	H	L	L
$V_{CCI-GND} < V_{VCCI_OFF}$ after device start up	L	L	L	L

Table 2. UCC21530 VDD UVLO Feature Logic

CONDITION	INPUTS		OUTPUTS	
	INA	INB	OUTA	OUTB
$V_{DD-VSS} < V_{VDD_ON}$ during device start up	H	L	L	L

Table 2. UCC21530 VDD UVLO Feature Logic (continued)

CONDITION	INPUTS		OUTPUTS	
	INA	INB	OUTA	OUTB
VDD-VSS < V _{VDD_ON} during device start up	L	H	L	L
VDD-VSS < V _{VDD_ON} during device start up	H	H	L	L
VDD-VSS < V _{VDD_ON} during device start up	L	L	L	L
VDD-VSS < V _{VDD_OFF} after device start up	H	L	L	L
VDD-VSS < V _{VDD_OFF} after device start up	L	H	L	L
VDD-VSS < V _{VDD_OFF} after device start up	H	H	L	L
VDD-VSS < V _{VDD_OFF} after device start up	L	L	L	L

8.3.2 Input and Output Logic Table

Assume VCCI, VDDA, VDDB are powered up. See [VDD, VCCI, and Under Voltage Lock Out \(UVLO\)](#) for more information on UVLO operation modes.

Table 3. INPUT/OUTPUT Logic Table⁽¹⁾

INPUTS		EN	OUTPUTS		NOTE
INA	INB		OUTA	OUTB	
L	L	H or Left Open	L	L	If Dead Time function is used, output transitions occur after the dead time expires. See Programmable Dead Time (DT) Pin
L	H	H or Left Open	L	H	
H	L	H or Left Open	H	L	
H	H	H or Left Open	L	L	DT is left open or programmed with R _{DT}
H	H	H or Left Open	H	H	DT pin pulled to VCCI
Left Open	Left Open	H or Left Open	L	L	-
X	X	L	L	L	Bypass using a ≥ 1-nF low ESR/ESL capacitor close to EN pin when connecting to a μC with distance

(1) "X" means L, H or left open.

8.3.3 Input Stage

The input signal pins (INA and INB) of UCC21530 are based on a TTL and CMOS compatible input-threshold logic that is totally isolated from the VDD supply voltage. The input pins are easy to drive with logic-level control signals (Such as those from 3.3-V micro-controllers), since UCC21530 has a typical high threshold (V_{INA/BH}) of 1.8 V and a typical low threshold of 1 V, which vary little with temperature (see [Figure 20, Figure 21](#)). A wide hysteresis (V_{INA/B_HYS}) of 0.8 V makes for good noise immunity and stable operation. If any of the inputs are ever left open, internal pull-down resistors force the pin low. These resistors are typically 200 kΩ (See [Functional Block Diagram](#)). However, it is still recommended to ground an input if it is not being used.

Since the input side of UCC21530 is isolated from the output drivers, the input signal amplitude can be larger or smaller than VDD, provided that it doesn't exceed the recommended limit. This allows greater flexibility when integrating with control signal sources, and allows the user to choose the most efficient VDD for their chosen gate. That said, the amplitude of any signal applied to INA or INB must *never* be at a voltage higher than VCCI.

8.3.4 Output Stage

The UCC21530's output stages features a pull-up structure which delivers the highest peak-source current when it is most needed, during the Miller plateau region of the power-switch turn on transition (when the power switch drain or collector voltage experiences dV/dt). The output stage pull-up structure features a P-channel MOSFET and an additional *Pull-Up* N-channel MOSFET in parallel. The function of the N-channel MOSFET is to provide a brief boost in the peak-sourcing current, enabling fast turn on. This is accomplished by briefly turning on the N-channel MOSFET during a narrow instant when the output is changing states from low to high. The on-resistance of this N-channel MOSFET (R_{NMOS}) is approximately $1.47\ \Omega$ when activated.

The R_{OH} parameter is a DC measurement and it is representative of the on-resistance of the P-channel device only. This is because the *Pull-Up* N-channel device is held in the off state in DC condition and is turned on only for a brief instant when the output is changing states from low to high. Therefore the effective resistance of the UCC21530 pull-up stage during this brief turn-on phase is much lower than what is represented by the R_{OH} parameter. Therefore, the value of R_{OH} belies the fast nature of the UCC21530's turn-on time.

The pull-down structure in UCC21530 is simply composed of an N-channel MOSFET. The R_{OL} parameter, which is also a DC measurement, is representative of the impedance of the pull-down state in the device. Both outputs of the UCC21530 are capable of delivering 4-A peak source and 6-A peak sink current pulses. The output voltage swings between VDD and VSS provides rail-to-rail operation, thanks to the MOS-out stage which delivers very low drop-out.

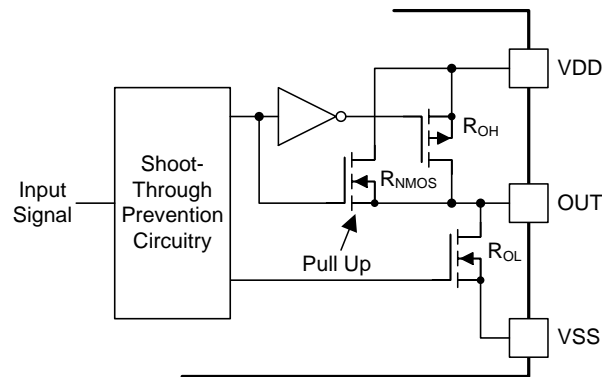

Figure 35. Output Stage

8.3.5 Diode Structure in UCC21530

Figure 36 illustrates the multiple diodes involved in the ESD protection components of the UCC21530. This provides a pictorial representation of the absolute maximum rating for the device.

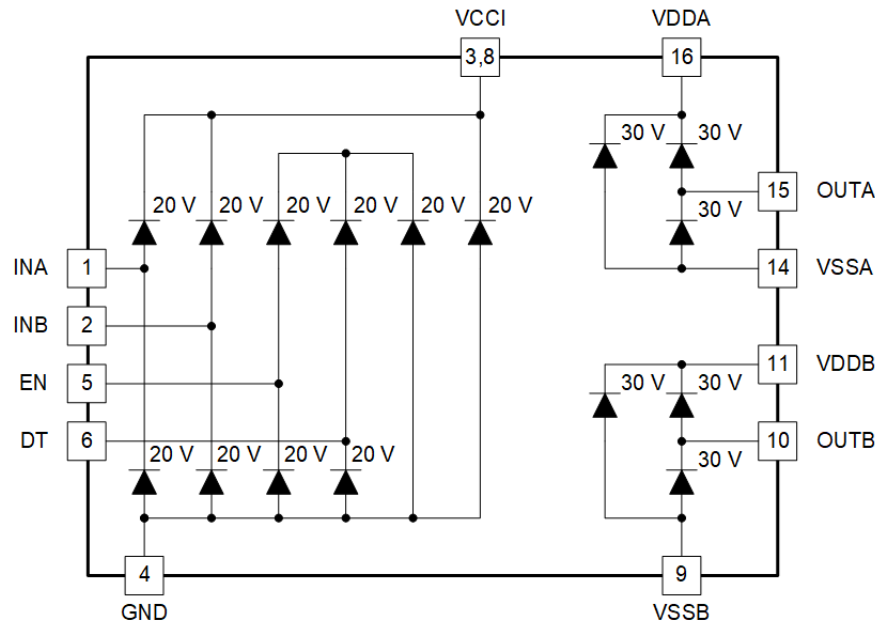

Figure 36. ESD Structure

8.4 Device Functional Modes

8.4.1 Enable Pin

Setting the EN pin low, i.e. $V_{EN} \leq 0.8V$, shuts down both outputs simultaneously. Pull the EN pin high (or left open), i.e. $V_{EN} \geq 2.0V$, allows UCC21530 to operate normally. The EN pin is quite responsive, as far as propagation delay and other switching parameters are concerned. The EN pin is only functional (and necessary) when VCCI stays above the UVLO threshold. It is highly recommended to tie this pin to VCCI directly if the EN pin is not used to achieve better noise immunity.

8.4.2 Programmable Dead Time (DT) Pin

UCC21530 allows the user to adjust dead time (DT) in the following ways:

8.4.2.1 DT Pin Tied to VCC

Outputs completely match inputs, so no minimum dead time is asserted. This allows outputs to overlap. It is recommended to connect this pin to VCCI directly if it is not used to achieve better noise immunity.

8.4.2.2 DT Pin Connected to a Programming Resistor between DT and GND Pins

Program t_{DT} by placing a resistor, R_{DT} , between the DT pin and GND. TI recommends bypassing this pin with a ceramic capacitor, 2.2 nF or greater, close to DT pin to achieve better noise immunity. The appropriate R_{DT} value can be determined from:

$$t_{DT} \approx 10 \times R_{DT}$$

where

- t_{DT} is the programmed dead time, in nanoseconds.
- R_{DT} is the value of resistance between DT pin and GND, in kilo-ohms.

(1)

Device Functional Modes (continued)

The steady state voltage at the DT pin is about 0.8 V. R_{DT} programs a small current at this pin, which sets the dead time. As the value of R_{DT} increases, the current sourced by the DT pin decreases. The DT pin current will be less than 10 μA when $R_{DT} = 100 \text{ k}\Omega$. For larger values of R_{DT} , TI recommends placing R_{DT} and a ceramic capacitor, 2.2 nF or greater, as close to the DT pin as possible to achieve greater noise immunity and better dead time matching between both channels.

The falling edge of an input signal initiates the programmed dead time for the other signal. The programmed dead time is the minimum enforced duration in which both outputs are held low by the driver. The outputs may also be held low for a duration greater than the programmed dead time, if the INA and INB signals include a dead time duration greater than the programmed minimum. If both inputs are high simultaneously, both outputs will immediately be set low. This feature is used to prevent shoot-through in half-bridge applications, and it does not affect the programmed dead time setting for normal operation. Various driver dead time logic operating conditions are illustrated and explained in [Figure 37](#).

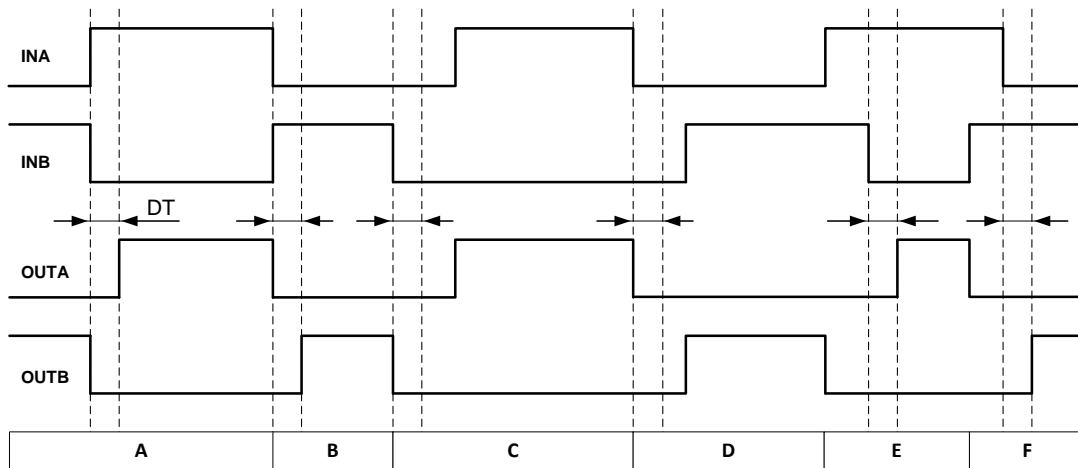

Figure 37. Input and Output Logic Relationship With Input Signals

Condition A: INB goes low, INA goes high. INB sets OUTB low immediately and assigns the programmed dead time to OUTA. OUTA is allowed to go high after the programmed dead time.

Condition B: INB goes high, INA goes low. Now INA sets OUTA low immediately and assigns the programmed dead time to OUTB. OUTB is allowed to go high after the programmed dead time.

Condition C: INB goes low, INA is still low. INB sets OUTB low immediately and assigns the programmed dead time for OUTA. In this case, the input signal's own dead time is longer than the programmed dead time. Thus, when INA goes high, it immediately sets OUTA high.

Condition D: INA goes low, INB is still low. INA sets OUTA low immediately and assigns the programmed dead time to OUTB. INB's own dead time is longer than the programmed dead time. Thus, when INB goes high, it immediately sets OUTB high.

Condition E: INA goes high, while INB and OUTB are still high. To avoid overshoot, INA immediately pulls OUTB low and keeps OUTA low. After some time OUTB goes low and assigns the programmed dead time to OUTA. OUTB is already low. After the programmed dead time, OUTA is allowed to go high.

Condition F: INB goes high, while INA and OUTA are still high. To avoid overshoot, INB immediately pulls OUTA low and keeps OUTB low. After some time OUTA goes low and assigns the programmed dead time to OUTB. OUTA is already low. After the programmed dead time, OUTB is allowed to go high.

9 Application and Implementation

NOTE

Information in the following applications sections is not part of the TI component specification, and TI does not warrant its accuracy or completeness. TI's customers are responsible for determining suitability of components for their purposes. Customers should validate and test their design implementation to confirm system functionality.

9.1 Application Information

The UCC21530 effectively combines both isolation and buffer-drive functions. The flexible, universal capability of the UCC21530 (with up to 18-V VCCI and 25-V VDDA/Vddb) allows the device to be used as a low-side, high-side, high-side/low-side or half-bridge driver for MOSFETs, IGBTs or SiC MOSFETs. With integrated components, advanced protection features (UVLO, dead time, and enable) and optimized switching performance; the UCC21530 enables designers to build smaller, more robust designs for enterprise, telecom, automotive, and industrial applications with a faster time to market.

9.2 Typical Application

The circuit in [Figure 38](#) shows a reference design with UCC21530 driving a typical half-bridge configuration which could be used in several popular power converter topologies such as synchronous buck, synchronous boost, half-bridge/full bridge isolated topologies, and 3-phase motor drive applications. This circuit uses two supplies (or single-input-double-output power supply). Power supply V_{A+} determines the positive drive output voltage and V_{A-} determines the negative turn-off voltage. The configuration for channel B is the same as channel A.

When parasitic inductances are introduced by non-ideal PCB layout and long package leads (e.g. TO-220 and TO-247 type packages), there could be ringing in the gate-source voltage of the power transistor during high di/dt and dv/dt switching. If the ringing is over the threshold voltage, there is the risk of unintended turn-on and even shoot-through. Applying a negative bias on the gate drive is a popular way to keep such ringing below the threshold. This solution has two separate power supplies for each driver channel, so it provides flexibility when setting the positive and negative rail voltages.

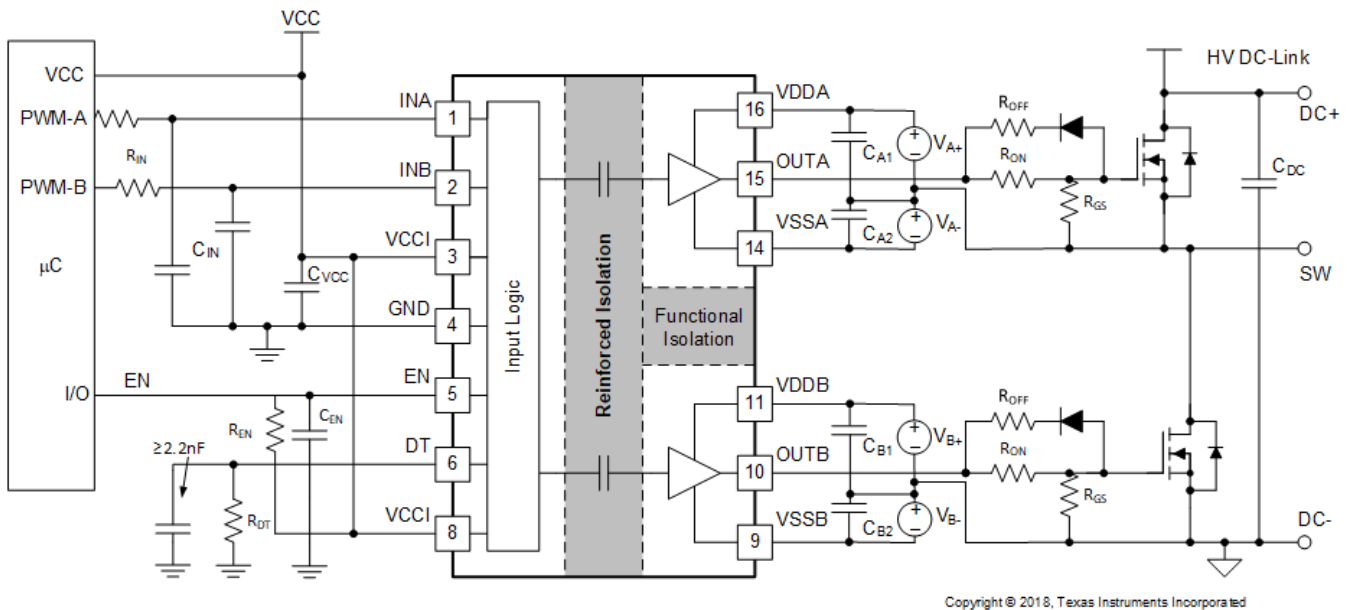

Figure 38. Typical Application Schematic with Dual Power Supplies

Typical Application (continued)

9.2.1 Design Requirements

Table 4 lists reference design parameters for the example application: UCC21530 driving 1000-V SiC-MOSFETs in a high side-low side configuration.

Table 4. UCC21530 Design Requirements

PARAMETER	VALUE	UNITS
Power transistor	C3M0065100K	–
VCC	5.0	V
VDD	15	V
VSS	–4	V
R _{ON}	2.2	Ω
R _{OFF}	0	Ω
Input signal amplitude	3.3	V
Switching frequency (f _s)	100	kHz
DC link voltage	600	V

9.2.2 Detailed Design Procedure

9.2.2.1 Designing INA/INB Input Filter

It is recommended that users avoid shaping the signals to the gate driver in an attempt to slow down (or delay) the signal at the output. However, a small input R_{IN}-C_{IN} filter can be used to filter out the ringing introduced by non-ideal layout or long PCB traces.

Such a filter should use an R_{IN} in the range of 0 Ω to 100 Ω and a C_{IN} between 10 pF and 100 pF. In the example, an R_{IN} = 51 Ω and a C_{IN} = 33 pF are selected, with a corner frequency of approximately 100 MHz.

When selecting these components, it is important to pay attention to the trade-off between good noise immunity and propagation delay.

9.2.2.2 Select Dead Time Resistor and Capacitor

From Equation 1, a 10-kΩ resistor is selected to set the dead time to 100 ns. A 2.2-nF capacitor is placed in parallel close to the DT pin to improve noise immunity.

9.2.2.3 Gate Driver Output Resistor

The external gate driver resistors, R_{ON}/R_{OFF}, are used to:

1. Limit ringing caused by parasitic inductances/capacitances.
2. Limit ringing caused by high voltage/current switching dv/dt, di/dt, and body-diode reverse recovery.
3. Fine-tune gate drive strength, i.e. peak sink and source current to optimize the switching loss.
4. Reduce electromagnetic interference (EMI).

As mentioned in [Output Stage](#), the UCC21530 has a pull-up structure with a P-channel MOSFET and an additional *pull-up* N-channel MOSFET in parallel. The combined peak source current is 4 A. Therefore, the peak source current can be predicted with:

$$I_{O+} = \min \left(4A, \frac{V_{DD} - V_{SS}}{R_{NMOS} \parallel R_{OH} + R_{ON} + R_{GFET_Int}} \right)$$

where

- R_{ON}: External turn-on resistance, R_{ON}=2.2 Ω in this example;
- R_{GFET_INT}: Power transistor internal gate resistance, found in the power transistor datasheet.
- I_{O+} = Peak source current – The minimum value between 4 A, the gate driver peak source current, and the calculated value based on the gate drive loop resistance.

(2)

In this example:

$$I_{O+} = \frac{V_{DD} - V_{SS}}{R_{NMOS} \parallel R_{OH} + R_{ON} + R_{GFET_Int}} = \frac{15V - (-4V)}{1.47\Omega \parallel 5\Omega + 2.2\Omega + 4.7\Omega} \approx 2.4A \quad (3)$$

Therefore, the driver peak source current is 2.4 A for each channel. Similarly, the peak sink current can be calculated with:

$$I_{O-} = \min\left(6A, \frac{V_{DD} - V_{SS} - V_{GDF}}{R_{OL} + R_{OFF} \parallel R_{ON} + R_{GFET_Int}}\right)$$

where

- R_{OFF} : External turn-off resistance, $R_{OFF}=0$ in this example;
- V_{GDF} : The anti-parallel diode forward voltage drop which is in series with R_{OFF} . The diode in this example is an MSS1P4.
- I_{O-} : Peak sink current – the minimum value between 6 A, the gate driver peak sink current, and the calculated value based on the gate drive loop resistance. (4)

In this example,

$$I_{O-} = \frac{V_{DD} - V_{SS} - V_{GDF}}{R_{OL} + R_{OFF} \parallel R_{ON} + R_{GFET_Int}} = \frac{15V - (-4V) - 0.75V}{0.55\Omega + 0\Omega + 4.7\Omega} \approx 3.5A \quad (5)$$

Therefore, the driver peak sink current is 3.5 A for each channel.

Importantly, the estimated peak current is also influenced by PCB layout and load capacitance. Parasitic inductance in the gate driver loop can slow down the peak gate drive current and introduce overshoot and undershoot. Therefore, it is strongly recommended that the gate driver loop should be minimized. On the other hand, the peak source/sink current is dominated by loop parasitics when the load capacitance (C_{ISS}) of the power transistor is very small (typically less than 1 nF), because the rising and falling time is too small and close to the parasitic ringing period.

9.2.2.4 Estimate Gate Driver Power Loss

The total loss, P_G , in the gate driver subsystem includes the power losses of the UCC21530 (P_{GD}) and the power losses in the peripheral circuitry, such as the external gate drive resistor. Bootstrap diode loss is not included in P_G and not discussed in this section.

P_{GD} is the key power loss which determines the thermal safety-related limits of the UCC21530, and it can be estimated by calculating losses from several components.

The first component is the static power loss, P_{GDQ} , which includes quiescent power loss on the driver as well as driver self-power consumption when operating with a certain switching frequency. P_{GDQ} is measured on the bench with no load connected to OUTA and OUTB at a given V_{CCI} , V_{DDA}/V_{DDB} , switching frequency and ambient temperature. [Figure 4](#) shows the per output channel current consumption vs. operating frequency with no load. In this example, $V_{CCI} = 5V$ and $V_{VDD} - V_{VSS} = 19V$. The current on each power supply, with INA/INB switching from 0 V to 3.3 V at 100 kHz is measured to be $I_{VCCI} \approx 2.5mA$, and $I_{VDDA} = I_{VDDB} \approx 1.5mA$. Therefore, the P_{GDQ} can be calculated with

$$P_{GDQ} = V_{VCCI} \times I_{VCCI} + (V_{VDDA} - V_{VSSA}) \times I_{DDA} + (V_{VDDB} - V_{VSSB}) \times I_{DDB} \approx 70mW \quad (6)$$

The second component is switching operation loss, P_{GDO} , with a given load capacitance which the driver charges and discharges the load during each switching cycle. Total dynamic loss due to load switching, P_{GSW} , can be estimated with

$$P_{GSW} = 2 \times (V_{DD} - V_{SS}) \times Q_G \times f_{SW}$$

where

- Q_G is the gate charge of the power transistor. (7)

If a split rail is used to turn on and turn off, then VDD is going to be equal to difference between the positive rail to the negative rail.

So, for this example application:

$$P_{GSW} = 2 \times 19V \times 35nC \times 100kHz = 133mW \quad (8)$$

Q_G represents the total gate charge of the power transistor switching 600 V at 20 A, and is subject to change with different testing conditions. The UCC21530 gate driver loss on the output stage, P_{GDO} , is part of P_{GSW} . P_{GDO} will be equal to P_{GSW} if the external gate driver resistances are zero, and all the gate driver loss is dissipated inside the UCC21530. If there are external turn-on and turn-off resistances, the total loss will be distributed between the gate driver pull-up/down resistances and external gate resistances. Importantly, the pull-up/down resistance is a linear and fixed resistance if the source/sink current is not saturated to 4 A/6 A, however, it will be non-linear if the source/sink current is saturated. Therefore, P_{GDO} is different in these two scenarios.

Case 1 - Linear Pull-Up/Down Resistor:

$$P_{GDO} = P_{GSW} \times \left(\frac{R_{OH} \parallel R_{NMOS}}{R_{OH} \parallel R_{NMOS} + R_{ON} + R_{GFET_Int}} + \frac{R_{OL}}{R_{OL} + R_{OFF} \parallel R_{ON} + R_{GFET_Int}} \right) \quad (9)$$

In this design example, all the predicted source/sink currents are less than 4 A/6 A, therefore, the UCC21530 gate driver loss can be estimated with:

$$P_{GDO} = 133mW \times \left(\frac{5\Omega \parallel 1.47\Omega}{5\Omega \parallel 1.47\Omega + 2.2\Omega + 4.7\Omega} + \frac{0.55\Omega}{0.55\Omega + 0\Omega + 4.7\Omega} \right) \approx 33mW \quad (10)$$

Case 2 - Nonlinear Pull-Up/Down Resistor:

$$P_{GDO} = 2 \times f_{SW} \times \left[4A \times \int_0^{T_{R_Sys}} (V_{DD} - V_{OUTA/B}(t)) dt + 6A \times \int_0^{T_{F_Sys}} (V_{OUTA/B}(t) - V_{SS}) dt \right]$$

where

- $V_{OUTA/B}(t)$ is the gate driver OUTA and OUTB pin voltage during the turn on and off transient, and it can be simplified that a constant current source (4 A at turn-on and 6 A at turn-off) is charging/discharging a load capacitor. Then, the $V_{OUTA/B}(t)$ waveform will be linear and the T_{R_Sys} and T_{F_Sys} can be easily predicted. (11)

For some scenarios, if only one of the pull-up or pull-down circuits is saturated and another one is not, the P_{GDO} will be a combination of Case 1 and Case 2, and the equations can be easily identified for the pull-up and pull-down based on the above discussion. Therefore, total gate driver loss dissipated in the gate driver UCC21530, P_{GD} , is:

$$P_{GD} = P_{GDU} + P_{GDD} \quad (12)$$

which is equal to 103 mW in the design example.

9.2.2.5 Estimating Junction Temperature

The junction temperature of the UCC21530 can be estimated with:

$$T_J = T_C + \Psi_{JT} \times P_{GD}$$

where

- T_J is the junction temperature.
- T_C is the UCC21530 case-top temperature measured with a thermocouple or some other instrument.
- Ψ_{JT} is the junction-to-top characterization parameter from the [Thermal Information](#) table. (13)

Using the junction-to-top characterization parameter (Ψ_{JT}) instead of the junction-to-case thermal resistance ($R_{\theta JC}$) can greatly improve the accuracy of the junction temperature estimation. The majority of the thermal energy of most ICs is released into the PCB through the package leads, whereas only a small percentage of the total energy is released through the top of the case (where thermocouple measurements are usually conducted). $R_{\theta JC}$ can only be used effectively when most of the thermal energy is released through the case, such as with metal packages or when a heatsink is applied to an IC package. In all other cases, use of $R_{\theta JC}$ will inaccurately estimate the true junction temperature. Ψ_{JT} is experimentally derived by assuming that the amount of energy leaving through the top of the IC will be similar in both the testing environment and the application environment. As long as the recommended layout guidelines are observed, junction temperature estimates can be made accurately to within a few degrees Celsius. For more information, see the [Layout Guidelines](#) and [Semiconductor and IC Package Thermal Metrics](#) application report.

9.2.2.6 Selecting VCCI, VDDA/B Capacitor

Bypass capacitors for VCCI, VDDA, and VDDB are essential for achieving reliable performance. It is recommended that one choose low ESR and low ESL surface-mount multi-layer ceramic capacitors (MLCC) with sufficient voltage ratings, temperature coefficients and capacitance tolerances. Importantly, DC bias on an MLCC will impact the actual capacitance value. For example, a 25-V, 1- μ F X7R capacitor is measured to be only 500 nF when a DC bias of 15 V_{DC} is applied.

9.2.2.6.1 Selecting a VCCI Capacitor

A bypass capacitor connected to VCCI supports the transient current needed for the primary logic and the total current consumption, which is only a few mA. Therefore, a 50-V MLCC with over 100 nF is recommended for this application. If the bias power supply output is a relatively long distance from the VCCI pin, a tantalum or electrolytic capacitor, with a value over 1 μ F, should be placed in parallel with the MLCC.

9.2.2.7 Other Application Example Circuits

When parasitic inductances are introduced by non-ideal PCB layout and long package leads (e.g. TO-220 and TO-247 type packages), there could be ringing in the gate-source drive voltage of the power transistor during high di/dt and dv/dt switching. If the ringing is over the threshold voltage, there is the risk of unintended turn-on and even shoot-through. Applying a negative bias on the gate drive is a popular way to keep such ringing below the threshold. Below are a few examples of implementing negative gate drive bias.

Instead of using two separate power for generating positive and negative drive voltage *Figure 39* shows the example with negative bias turn-off on the channel-A driver using a Zener diode on the isolated power supply output stage. The negative bias is set by the Zener diode voltage. If the isolated power supply, V_A , is equal to 19 V, the turn-off voltage will be -3.9 V and turn-on voltage will be $19\text{ V} - 3.9\text{ V} \approx 15\text{ V}$. The channel-B driver circuit is the same as channel-A, therefore, this configuration needs only one power supply for each driver channel, and there will be steady state power consumption from R_Z .

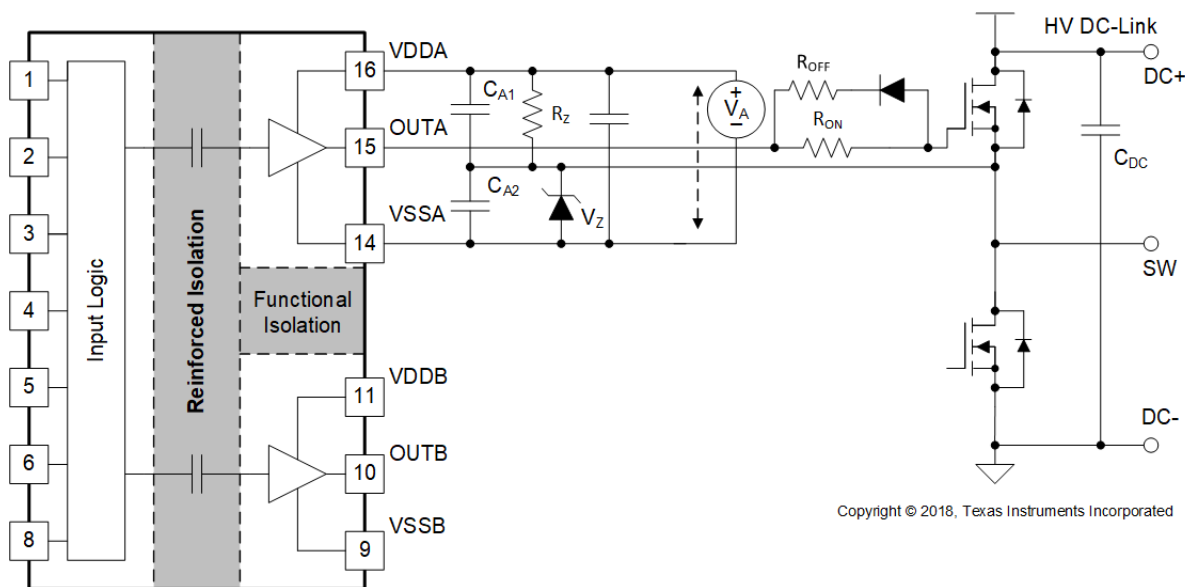

Copyright © 2018, Texas Instruments Incorporated

Figure 39. Negative Bias with Zener Diode on Iso-Bias Power Supply Output

ADVANCE INFORMATION

Figure 40 shows another example which uses bootstrap to provide power for the channel A, this solution doesn't have negative rail voltage, it is only suitable for circuits with less ringing or the power device has high threshold voltage.

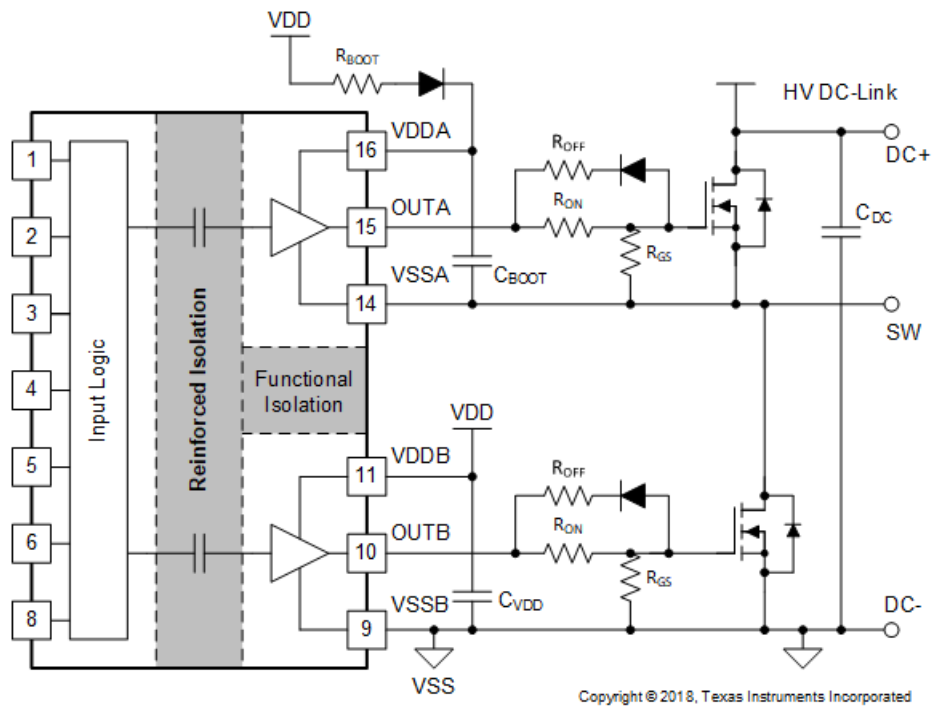
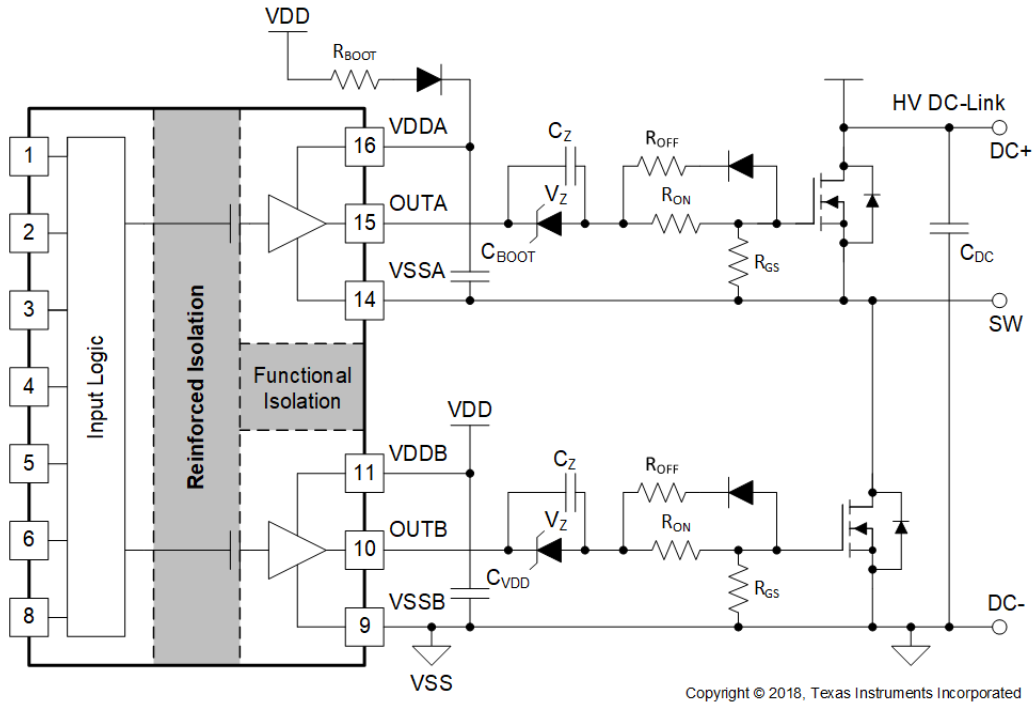

Figure 40. Bootstrap Power Supply for the High Side Device

The last example, shown in [Figure 41](#), is a single power supply configuration and generates negative bias through a Zener diode in the gate drive loop. The benefit of this solution is that it only uses one power supply and the bootstrap power supply can be used for the high side drive. This design requires the least cost and design effort among the three solutions. However, this solution has limitations:

1. The negative gate drive bias is not only determined by the Zener diode, but also by the duty cycle, which means the negative bias voltage will change when the duty cycle changes. Therefore, converters with a fixed duty cycle (~50%) such as variable frequency resonant converters or phase shift converters which favor this solution.
2. The high side VDDA-VSSA must maintain enough voltage to stay in the recommended power supply range, which means the low side switch must turn-on or have free-wheeling current on the body (or anti-parallel) diode for a certain period during each switching cycle to refresh the bootstrap capacitor. Therefore, a 100% duty cycle for the high side is not possible unless there is a dedicated power supply for the high side, like in the other two example circuits.



Copyright © 2018, Texas Instruments Incorporated

Figure 41. Negative Bias with Single Power Supply and Zener Diode in Gate Drive Path

ADVANCE INFORMATION

9.2.3 Application Curves

Figure 42 shows a multiple pulses bench test circuit which uses L1 as the inductor load, and a group of control pulses are generated to evaluate driver and SiC MOSFET switching transient under different load conditions. The test conditions are: $V_{DC-Link} = 600\text{ V}$, $V_{CC} = 5\text{ V}$, $V_{DD} = 15\text{ V}$, $V_{SS} = -4\text{ V}$, $f_{SW} = 500\text{ kHz}$, $R_{ON} = 5.1\ \Omega$, $R_{OFF} = 1.0\ \Omega$. Figure 43 shows the turn on and turn off waveforms at around 20 A current

Channel 1 (Yellow): Gate-source voltage signal on the low side MOSFET.

Channel 2 (Blue): Gate-source voltage signal on the high side MOSFET.

Channel 3 (Pink): Drain-source voltage signal for the low side MOSFET.

Channel 4 (Green): Drain-source current signal for the low side MOSFET.

In Figure 43, the gate drive signals on the high and low power transistor have a 100-ns dead time, and both signals are measured with $\geq 500\text{ MHz}$ bandwidth probes.

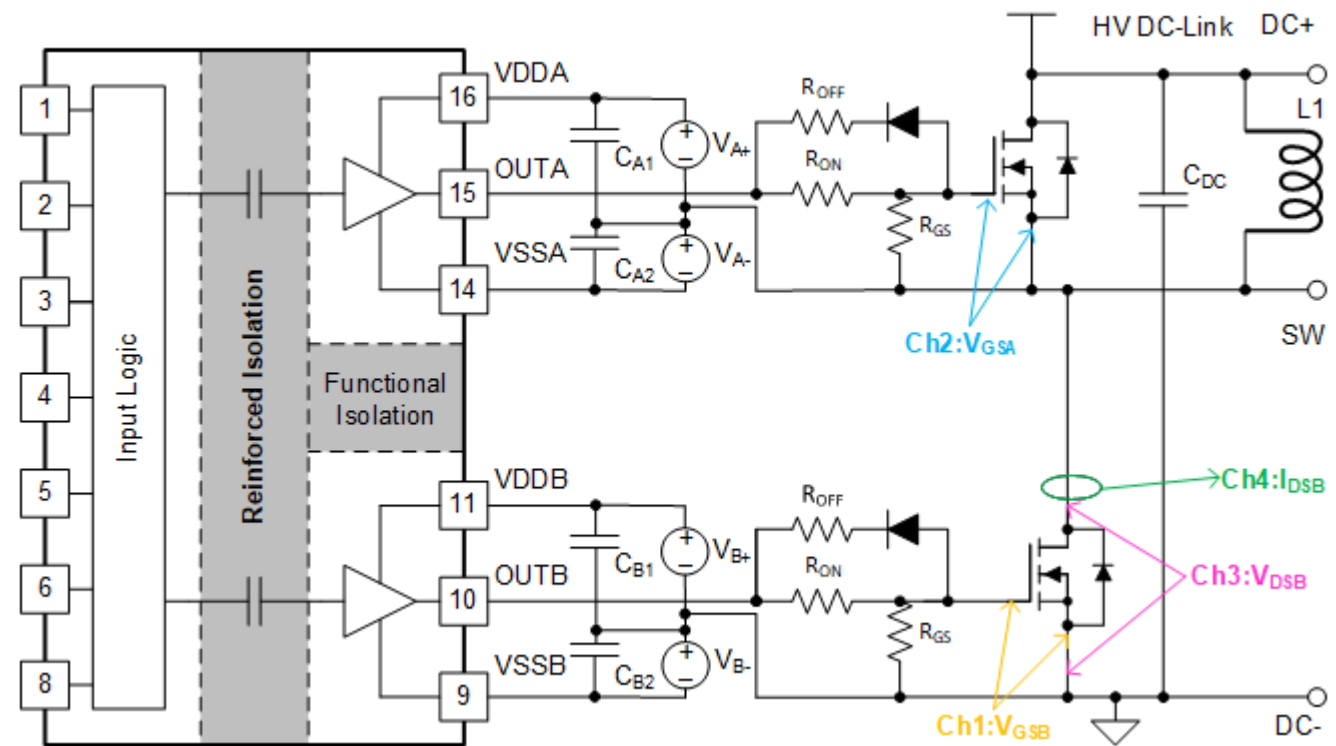

Figure 42. Bench Test Circuit with SiC MOSFET Switching



Figure 43. SiC MOSFET Switching Waveforms

ADVANCE INFORMATION

10 Power Supply Recommendations

The recommended input supply voltage (VCCI) for UCC21530 is between 3 V and 18 V. The output bias supply voltage (VDDA/VDDDB) range depends on which version of UCC21530 one is using. The lower end of this bias supply range is governed by the internal under voltage lockout (UVLO) protection feature of each device. One mustn't let VDD or VCCI fall below their respective UVLO thresholds (For more information on UVLO see [VDD](#), [VCCI](#), and [Under Voltage Lock Out \(UVLO\)](#)). The upper end of the VDDA/VDDDB range depends on the maximum gate voltage of the power device being driven by UCC21530. All versions of UCC21530 have a recommended maximum VDDA/VDDDB of 25 V.

A local bypass capacitor should be placed between the VDD and VSS pins. This capacitor should be positioned as close to the device as possible. A low ESR, ceramic surface mount capacitor is recommended. It is further suggested that one place two such capacitors: one with a value of between 220 nF and 10 μ F for device biasing, and an additional 100-nF capacitor in parallel for high frequency filtering.

Similarly, a bypass capacitor should also be placed between the VCCI and GND pins. Given the small amount of current drawn by the logic circuitry within the input side of UCC21530, this bypass capacitor has a minimum recommended value of 100 nF.

11 Layout

11.1 Layout Guidelines

Consider these PCB layout guidelines for in order to achieve optimum performance for the UCC21530.

11.1.1 Component Placement Considerations

- Low-ESR and low-ESL capacitors must be connected close to the device between the VCCI and GND pins and between the VDD and VSS pins to support high peak currents when turning on the external power transistor.
- To avoid large negative transients on the switch node VSSA (HS) pin in bridge configurations, the parasitic inductances between the source of the top transistor and the source of the bottom transistor must be minimized.
- To improve noise immunity when driving the EN pin from a distant micro-controller, TI recommends adding a small bypass capacitor, ≥ 1 nF, between the EN pin and GND.
- If the dead time feature is used, TI recommends placing the programming resistor R_{DT} and bypassing capacitor close to the DT pin of the UCC21530 to prevent noise from unintentionally coupling to the internal dead time circuit. The capacitor should be ≥ 2.2 nF.

11.1.2 Grounding Considerations

- It is essential to confine the high peak currents that charge and discharge the transistor gates to a minimal physical area. This will decrease the loop inductance and minimize noise on the gate terminals of the transistors. The gate driver must be placed as close as possible to the transistors.
- Pay attention to high current path that includes the bootstrap capacitor, bootstrap diode, local VSSB-referenced bypass capacitor, and the low-side transistor body/anti-parallel diode. The bootstrap capacitor is recharged on a cycle-by-cycle basis through the bootstrap diode by the VDD bypass capacitor. This recharging occurs in a short time interval and involves a high peak current. Minimizing this loop length and area on the circuit board is important for ensuring reliable operation.

11.1.3 High-Voltage Considerations

- To ensure isolation performance between the primary and secondary side, avoid placing any PCB traces or copper below the driver device. A PCB cutout is recommended in order to prevent contamination that may compromise the isolation performance.
- For half-bridge or high-side/low-side configurations, maximize the clearance distance of the PCB layout between the high and low-side PCB traces.

11.1.4 Thermal Considerations

- A large amount of power may be dissipated by the UCC21530 if the driving voltage is high, the load is heavy, or the switching frequency is high (refer to [Estimate Gate Driver Power Loss](#) for more details). Proper PCB layout can help dissipate heat from the device to the PCB and minimize junction to board thermal impedance (θ_{JB}).
- Increasing the PCB copper connecting to VDDA, VDDB, VSSA and VSSB pins is recommended, with priority on maximizing the connection to VSSA and VSSB (see [Figure 45](#) and [Figure 46](#)). However, high voltage PCB considerations mentioned above must be maintained.
- If there are multiple layers in the system, it is also recommended to connect the VDDA, VDDB, VSSA and VSSB pins to internal ground or power planes through multiple vias of adequate size. Ensure that no traces or copper from different high-voltage planes overlap.

11.2 Layout Example

Figure 44 shows a 2-layer PCB layout example with the signals and key components labeled.

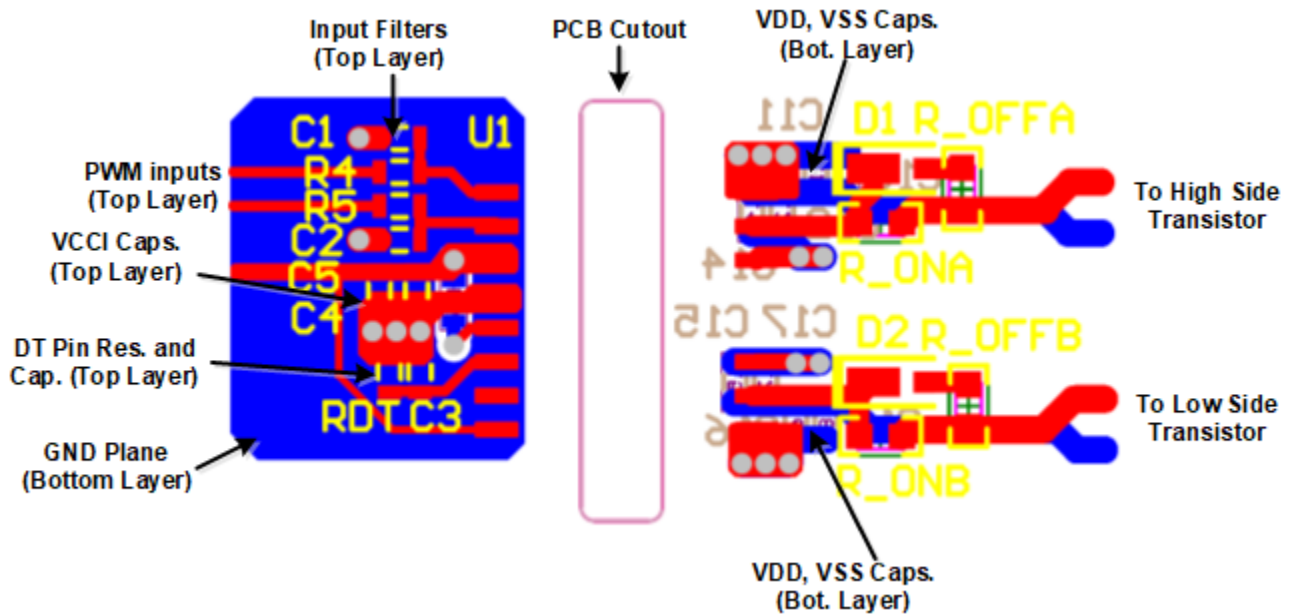

Figure 44. Layout Example

Figure 45 and Figure 46 shows top and bottom layer traces and copper.

NOTE

There are no PCB traces or copper between the primary and secondary side, which ensures isolation performance.

PCB traces between the high-side and low-side gate drivers in the output stage are increased to maximize the creepage distance for high-voltage operation, which will also minimize cross-talk between the switching node VSSA (SW), where high dv/dt may exist, and the low-side gate drive due to the parasitic capacitance coupling.

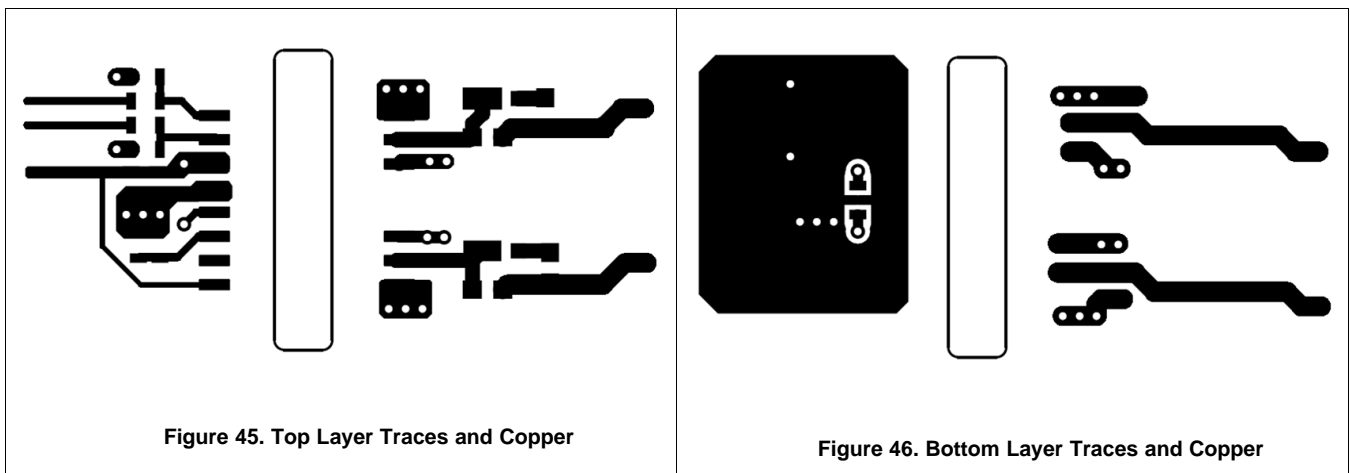

Figure 45. Top Layer Traces and Copper

Figure 46. Bottom Layer Traces and Copper

Layout Example (continued)

Figure 47 and Figure 48 are 3D layout pictures with top view and bottom views.

NOTE

The location of the PCB cutout between the primary side and secondary sides, which ensures isolation performance.

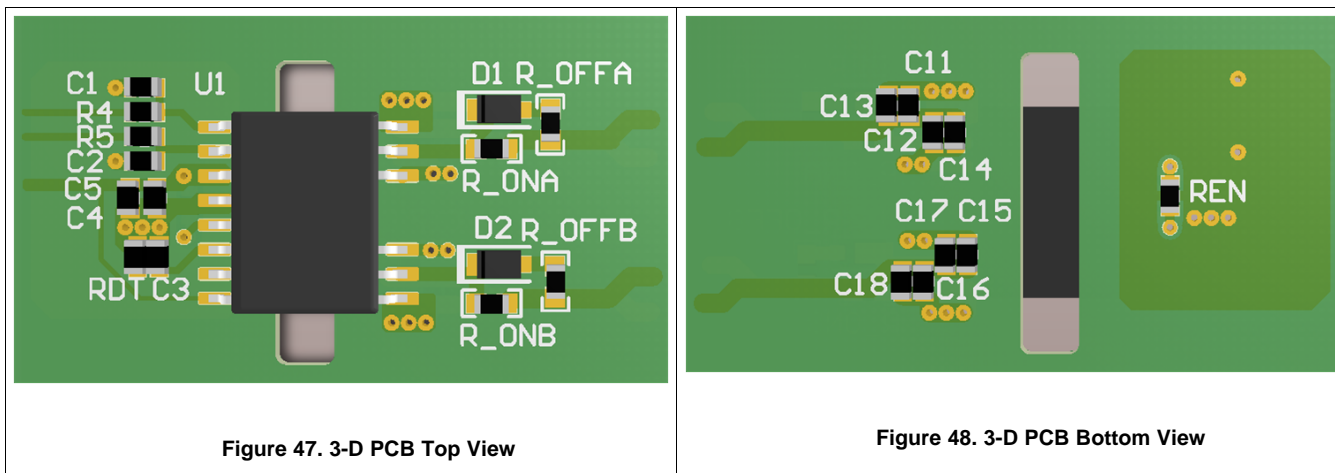

Figure 47. 3-D PCB Top View

Figure 48. 3-D PCB Bottom View

ADVANCE INFORMATION

12 Device and Documentation Support

12.1 Documentation Support

12.1.1 Related Documentation

For related documentation see the following:

- [Isolation Glossary](#)

12.2 Related Links

The table below lists quick access links. Categories include technical documents, support and community resources, tools and software, and quick access to sample or buy.

Table 5. Related Links

PARTS	PRODUCT FOLDER	SAMPLE & BUY	TECHNICAL DOCUMENTS	TOOLS & SOFTWARE	SUPPORT & COMMUNITY
UCC21530	Click here	Click here	Click here	Click here	Click here

12.3 Receiving Notification of Documentation Updates

To receive notification of documentation updates, navigate to the device product folder on ti.com. In the upper right corner, click on *Alert me* to register and receive a weekly digest of any product information that has changed. For change details, review the revision history included in any revised document.

12.4 Community Resources

The following links connect to TI community resources. Linked contents are provided "AS IS" by the respective contributors. They do not constitute TI specifications and do not necessarily reflect TI's views; see TI's [Terms of Use](#).

TI E2E™ Online Community *TI's Engineer-to-Engineer (E2E) Community*. Created to foster collaboration among engineers. At e2e.ti.com, you can ask questions, share knowledge, explore ideas and help solve problems with fellow engineers.

Design Support *TI's Design Support* Quickly find helpful E2E forums along with design support tools and contact information for technical support.

12.5 Trademarks

E2E is a trademark of Texas Instruments.

12.6 Electrostatic Discharge Caution



These devices have limited built-in ESD protection. The leads should be shorted together or the device placed in conductive foam during storage or handling to prevent electrostatic damage to the MOS gates.

12.7 Glossary

[SLYZ022](#) — *TI Glossary*.

This glossary lists and explains terms, acronyms, and definitions.

13 Mechanical, Packaging, and Orderable Information

The following pages include mechanical, packaging, and orderable information. This information is the most current data available for the designated devices. This data is subject to change without notice and revision of this document. For browser-based versions of this data sheet, refer to the left-hand navigation.

13.1 Package Option Addendum

13.1.1 Packaging Information

Orderable Device	Status ⁽¹⁾	Package Type	Package Drawing	Pins	Package Qty	Eco Plan ⁽²⁾	Lead/Ball Finish ⁽³⁾	MSL Peak Temp ⁽⁴⁾	Op Temp (°C)	Device Marking ⁽⁵⁾⁽⁶⁾
PUCC21530DWK	Active	SOIC	DWK	14	40	TBD	Call TI	Call TI	-40 to 125	PUCC21530
PUCC21530DWKR	Active	SOIC	DWK	14	2000	TBD	Call TI	Call TI	-40 to 125	PUCC21530
UCC21530DWK	Preview	SOIC	DWK	14	40	TBD	Call TI	Call TI	-40 to 125	UCC21530
UCC21530DWKR	Preview	SOIC	DWK	14	2000	TBD	Call TI	Call TI	-40 to 125	UCC21530

- (1) The marketing status values are defined as follows:
ACTIVE: Product device recommended for new designs.
LIFEBUY: TI has announced that the device will be discontinued, and a lifetime-buy period is in effect.
NRND: Not recommended for new designs. Device is in production to support existing customers, but TI does not recommend using this part in a new design.
PRE_PROD Unannounced device, not in production, not available for mass market, nor on the web, samples not available.
PREVIEW: Device has been announced but is not in production. Samples may or may not be available.
OBSOLETE: TI has discontinued the production of the device.
- (2) Eco Plan - The planned eco-friendly classification: Pb-Free (RoHS), Pb-Free (RoHS Exempt), or Green (RoHS & no Sb/Br) - please check <http://www.ti.com/productcontent> for the latest availability information and additional product content details.
TBD: The Pb-Free/Green conversion plan has not been defined.
Pb-Free (RoHS): TI's terms "Lead-Free" or "Pb-Free" mean semiconductor products that are compatible with the current RoHS requirements for all 6 substances, including the requirement that lead not exceed 0.1% by weight in homogeneous materials. Where designed to be soldered at high temperatures, TI Pb-Free products are suitable for use in specified lead-free processes.
Pb-Free (RoHS Exempt): This component has a RoHS exemption for either 1) lead-based flip-chip solder bumps used between the die and package, or 2) lead-based die adhesive used between the die and leadframe. The component is otherwise considered Pb-Free (RoHS compatible) as defined above.
Green (RoHS & no Sb/Br): TI defines "Green" to mean Pb-Free (RoHS compatible), and free of Bromine (Br) and Antimony (Sb) based flame retardants (Br or Sb do not exceed 0.1% by weight in homogeneous material)
- (3) Lead/Ball Finish - Orderable Devices may have multiple material finish options. Finish options are separated by a vertical ruled line. Lead/Ball Finish values may wrap to two lines if the finish value exceeds the maximum column width.
- (4) MSL, Peak Temp. -- The Moisture Sensitivity Level rating according to the JEDEC industry standard classifications, and peak solder temperature.
- (5) There may be additional marking, which relates to the logo, the lot trace code information, or the environmental category on the device
- (6) Multiple Device markings will be inside parentheses. Only one Device Marking contained in parentheses and separated by a "-" will appear on a device. If a line is indented then it is a continuation of the previous line and the two combined represent the entire Device Marking for that device.

Important Information and Disclaimer: The information provided on this page represents TI's knowledge and belief as of the date that it is provided. TI bases its knowledge and belief on information provided by third parties, and makes no representation or warranty as to the accuracy of such information. Efforts are underway to better integrate information from third parties. TI has taken and continues to take reasonable steps to provide representative and accurate information but may not have conducted destructive testing or chemical analysis on incoming materials and chemicals. TI and TI suppliers consider certain information to be proprietary, and thus CAS numbers and other limited information may not be available for release.

In no event shall TI's liability arising out of such information exceed the total purchase price of the TI part(s) at issue in this document sold by TI to Customer on an annual basis.

UCC21530

SLUSDC0–NOVEMBER 2018

www.ti.com

13.1.2 Tape and Reel Information

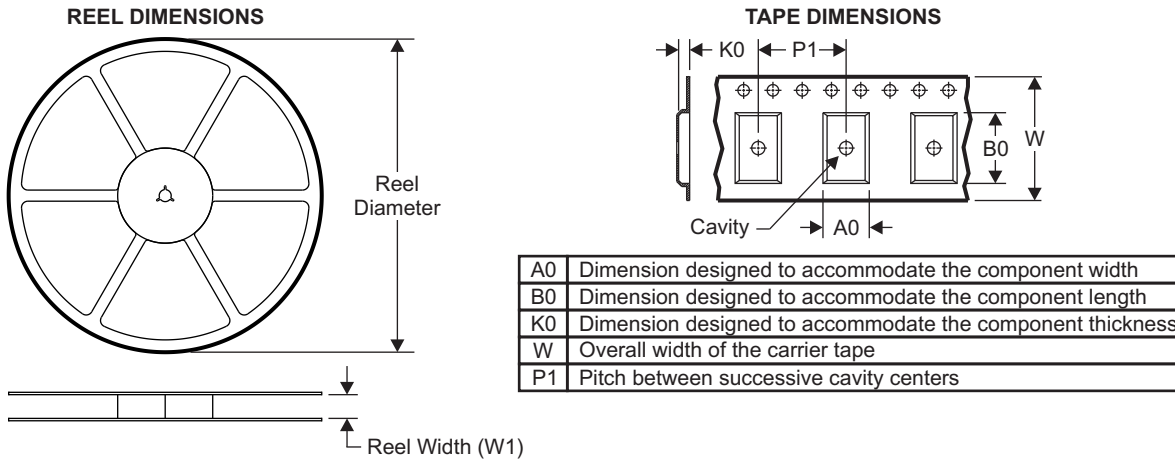

QUADRANT ASSIGNMENTS FOR PIN 1 ORIENTATION IN TAPE

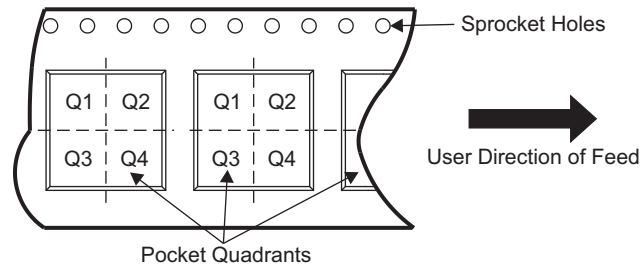

Device	Package Type	Package Drawing	Pins	SPQ	Reel Diameter (mm)	Reel Width W1 (mm)	A0 (mm)	B0 (mm)	K0 (mm)	P1 (mm)	W (mm)	Pin1 Quadrant
PUC21530DWKR	SOIC	DWK	14	2000	330.0	16.4	10.75	10.7	2.7	12.0	16.0	Q1

ADVANCE INFORMATION

TAPE AND REEL BOX DIMENSIONS

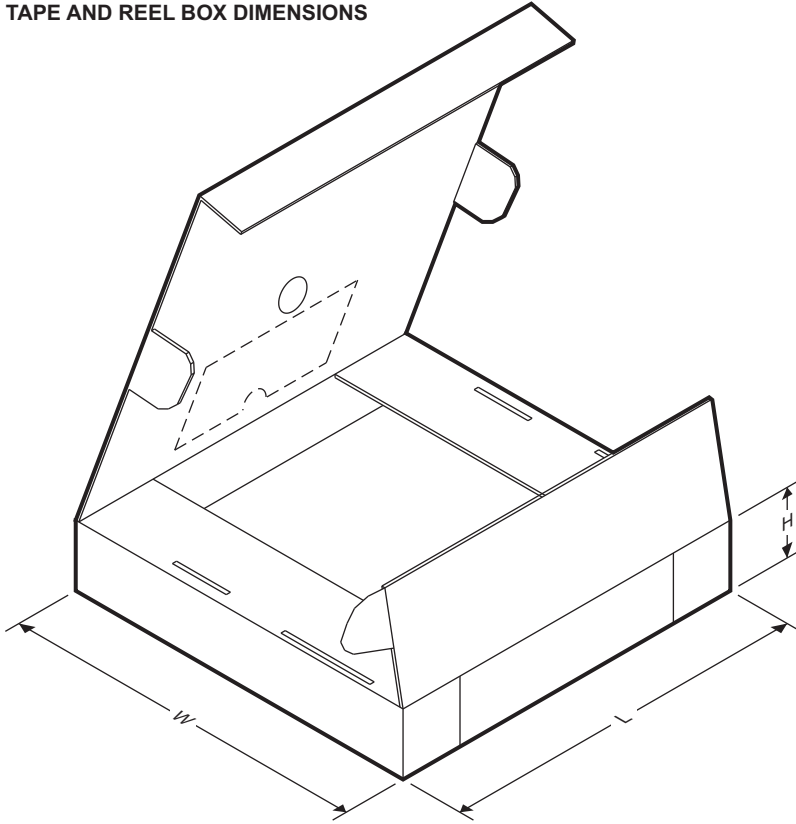

Device	Package Type	Package Drawing	Pins	SPQ	Length (mm)	Width (mm)	Height (mm)
PUC21530DWKR	SOIC	DWK	14	2000	367.0	367.0	38.0

ADVANCE INFORMATION

DWK0014A

PACKAGE OUTLINE

SOIC - 2.65 mm max height

SMALL OUTLINE INTEGRATED CIRCUIT

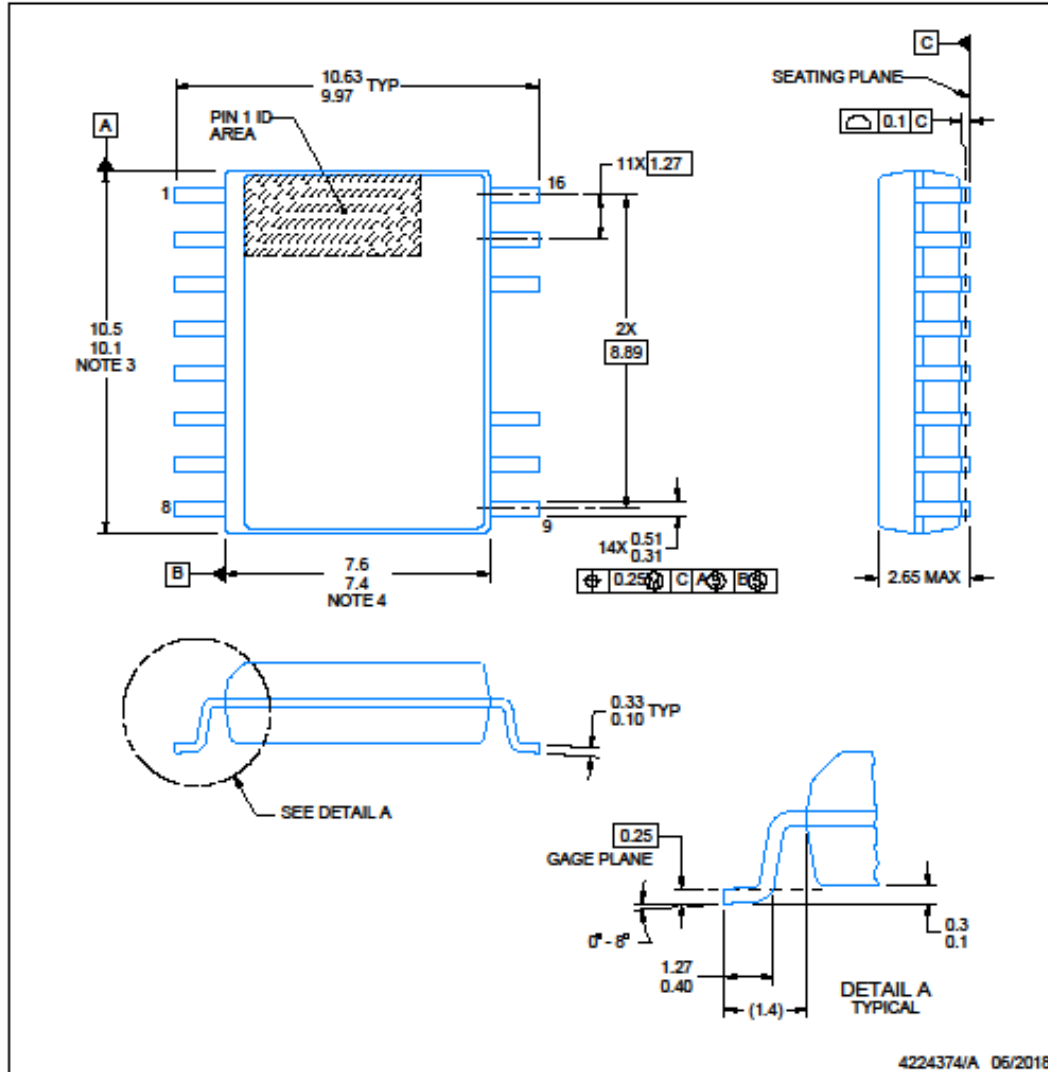

NOTES:

1. All linear dimensions are in millimeters. Dimensions in parenthesis are for reference only. Dimensioning and tolerancing per ASME Y14.5M.
2. This drawing is subject to change without notice.
3. This dimension does not include mold flash, protrusions, or gate burrs. Mold flash, protrusions, or gate burrs shall not exceed 0.15 mm, per side.
4. This dimension does not include interlead flash. Interlead flash shall not exceed 0.25 mm, per side.
5. Reference JEDEC registration MS-013.

EXAMPLE BOARD LAYOUT

DWK0014A

SOIC - 2.65 mm max height

SMALL OUTLINE INTEGRATED CIRCUIT

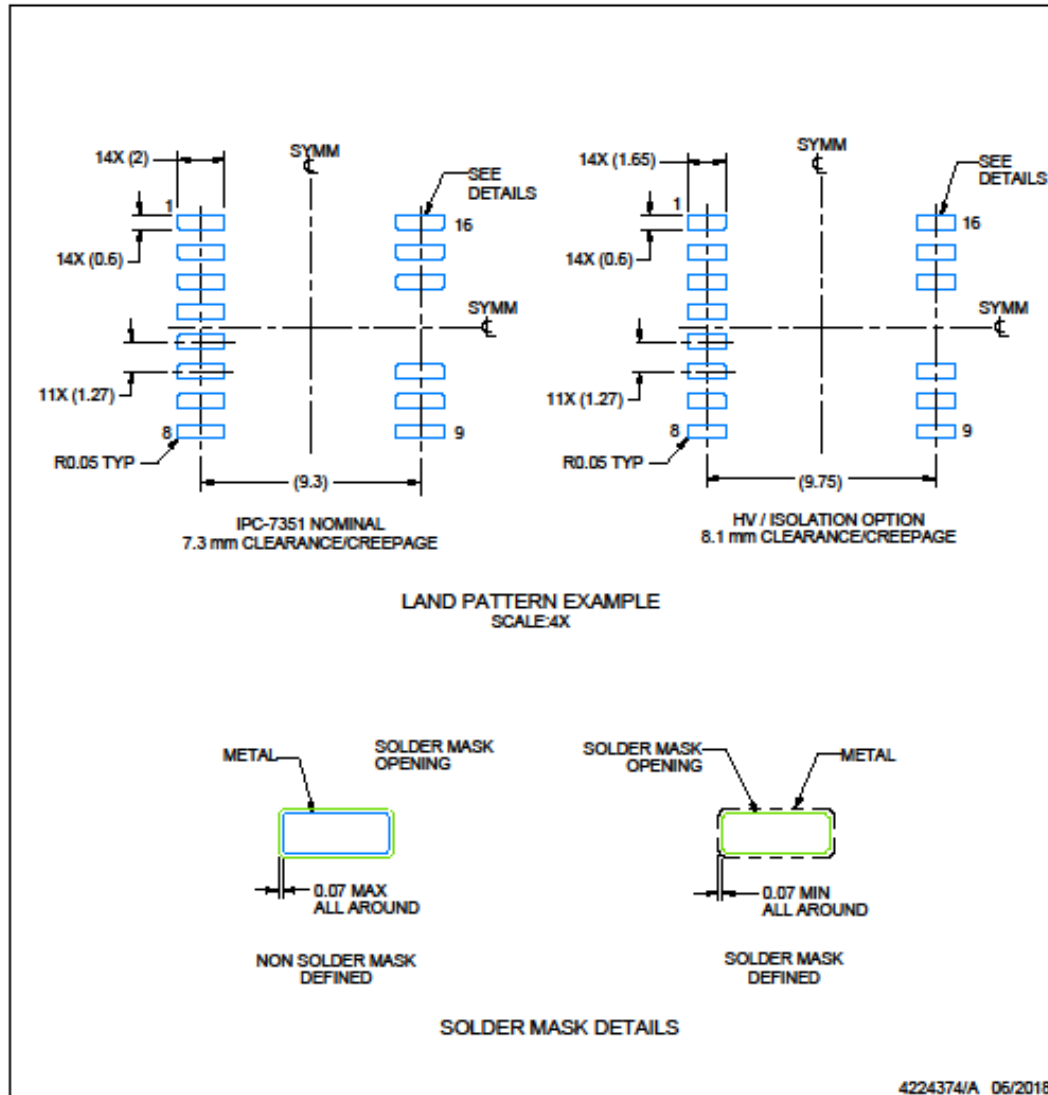

NOTES: (continued)

- 6. Publication IPC-7351 may have alternate designs.
- 7. Solder mask tolerances between and around signal pads can vary based on board fabrication site.

ADVANCE INFORMATION

DWK0014A

EXAMPLE STENCIL DESIGN

SOIC - 2.65 mm max height

SMALL OUTLINE INTEGRATED CIRCUIT

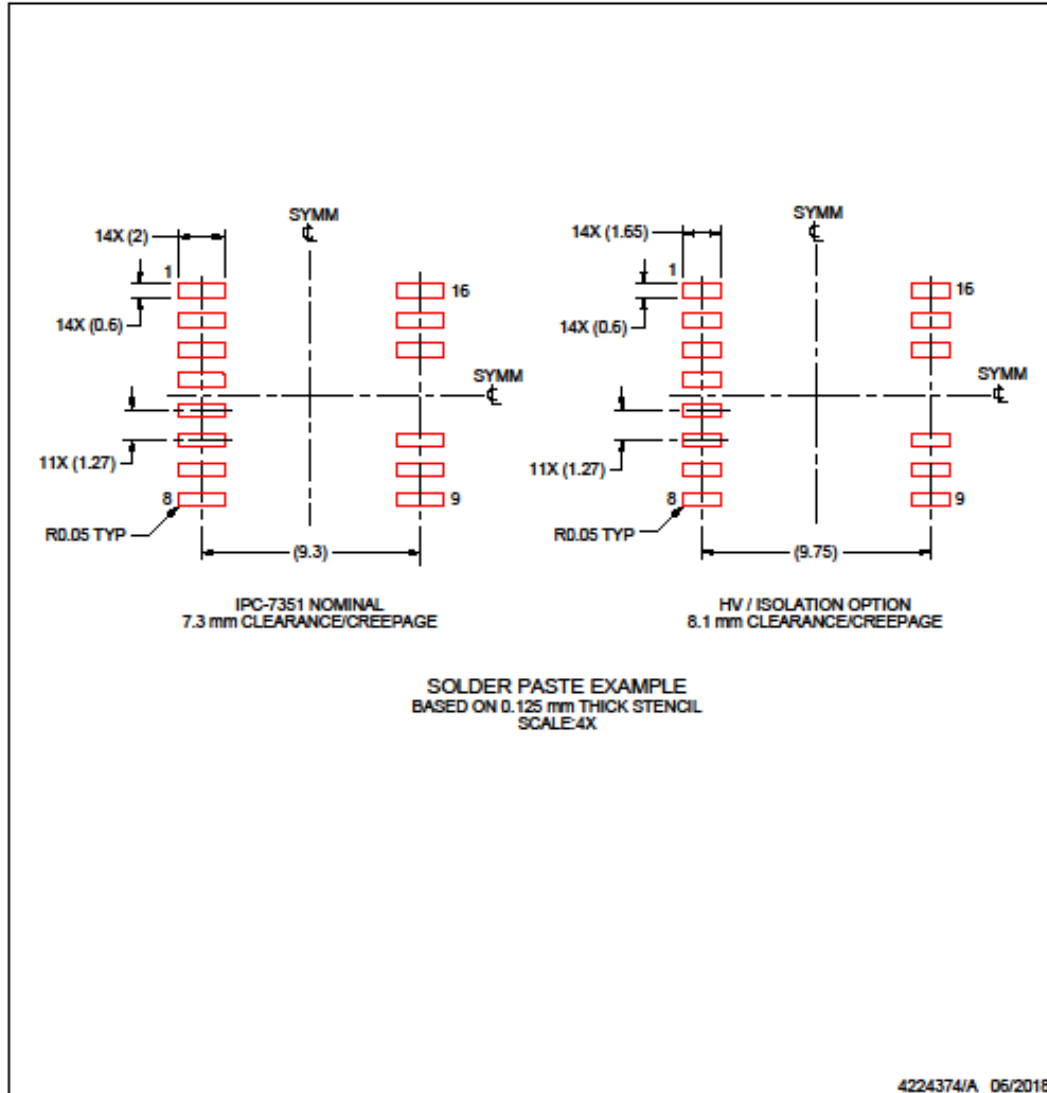

NOTES: (continued)

- 8. Laser cutting apertures with trapezoidal walls and rounded corners may offer better paste release. IPC-7525 may have alternate design recommendations.
- 9. Board assembly site may have different recommendations for stencil design.

PACKAGING INFORMATION

Orderable Device	Status (1)	Package Type	Package Drawing	Pins	Package Qty	Eco Plan (2)	Lead/Ball Finish (6)	MSL Peak Temp (3)	Op Temp (°C)	Device Marking (4/5)	Samples
PUCC21530DWK	ACTIVE	SOIC	DWK	14	40	TBD	Call TI	Call TI	-40 to 125		Samples
UCC21530DWK	PREVIEW	SOIC	DWK	14	40	TBD	Call TI	Call TI	-40 to 125		
UCC21530DWKR	PREVIEW	SOIC	DWK	14	2000	TBD	Call TI	Call TI	-40 to 125		

(1) The marketing status values are defined as follows:

ACTIVE: Product device recommended for new designs.

LIFEBUY: TI has announced that the device will be discontinued, and a lifetime-buy period is in effect.

NRND: Not recommended for new designs. Device is in production to support existing customers, but TI does not recommend using this part in a new design.

PREVIEW: Device has been announced but is not in production. Samples may or may not be available.

OBSOLETE: TI has discontinued the production of the device.

(2) **RoHS:** TI defines "RoHS" to mean semiconductor products that are compliant with the current EU RoHS requirements for all 10 RoHS substances, including the requirement that RoHS substance do not exceed 0.1% by weight in homogeneous materials. Where designed to be soldered at high temperatures, "RoHS" products are suitable for use in specified lead-free processes. TI may reference these types of products as "Pb-Free".

RoHS Exempt: TI defines "RoHS Exempt" to mean products that contain lead but are compliant with EU RoHS pursuant to a specific EU RoHS exemption.

Green: TI defines "Green" to mean the content of Chlorine (Cl) and Bromine (Br) based flame retardants meet JS709B low halogen requirements of <=1000ppm threshold. Antimony trioxide based flame retardants must also meet the <=1000ppm threshold requirement.

(3) MSL, Peak Temp. - The Moisture Sensitivity Level rating according to the JEDEC industry standard classifications, and peak solder temperature.

(4) There may be additional marking, which relates to the logo, the lot trace code information, or the environmental category on the device.

(5) Multiple Device Markings will be inside parentheses. Only one Device Marking contained in parentheses and separated by a "-" will appear on a device. If a line is indented then it is a continuation of the previous line and the two combined represent the entire Device Marking for that device.

(6) Lead/Ball Finish - Orderable Devices may have multiple material finish options. Finish options are separated by a vertical ruled line. Lead/Ball Finish values may wrap to two lines if the finish value exceeds the maximum column width.

Important Information and Disclaimer:The information provided on this page represents TI's knowledge and belief as of the date that it is provided. TI bases its knowledge and belief on information provided by third parties, and makes no representation or warranty as to the accuracy of such information. Efforts are underway to better integrate information from third parties. TI has taken and continues to take reasonable steps to provide representative and accurate information but may not have conducted destructive testing or chemical analysis on incoming materials and chemicals. TI and TI suppliers consider certain information to be proprietary, and thus CAS numbers and other limited information may not be available for release.

In no event shall TI's liability arising out of such information exceed the total purchase price of the TI part(s) at issue in this document sold by TI to Customer on an annual basis.

OTHER QUALIFIED VERSIONS OF UCC21530 :

- Automotive: [UCC21530-Q1](#)

NOTE: Qualified Version Definitions:

- Automotive - Q100 devices qualified for high-reliability automotive applications targeting zero defects

IMPORTANT NOTICE AND DISCLAIMER

TI PROVIDES TECHNICAL AND RELIABILITY DATA (INCLUDING DATASHEETS), DESIGN RESOURCES (INCLUDING REFERENCE DESIGNS), APPLICATION OR OTHER DESIGN ADVICE, WEB TOOLS, SAFETY INFORMATION, AND OTHER RESOURCES "AS IS" AND WITH ALL FAULTS, AND DISCLAIMS ALL WARRANTIES, EXPRESS AND IMPLIED, INCLUDING WITHOUT LIMITATION ANY IMPLIED WARRANTIES OF MERCHANTABILITY, FITNESS FOR A PARTICULAR PURPOSE OR NON-INFRINGEMENT OF THIRD PARTY INTELLECTUAL PROPERTY RIGHTS.

These resources are intended for skilled developers designing with TI products. You are solely responsible for (1) selecting the appropriate TI products for your application, (2) designing, validating and testing your application, and (3) ensuring your application meets applicable standards, and any other safety, security, or other requirements. These resources are subject to change without notice. TI grants you permission to use these resources only for development of an application that uses the TI products described in the resource. Other reproduction and display of these resources is prohibited. No license is granted to any other TI intellectual property right or to any third party intellectual property right. TI disclaims responsibility for, and you will fully indemnify TI and its representatives against, any claims, damages, costs, losses, and liabilities arising out of your use of these resources.

TI's products are provided subject to TI's Terms of Sale (www.ti.com/legal/termsofsale.html) or other applicable terms available either on ti.com or provided in conjunction with such TI products. TI's provision of these resources does not expand or otherwise alter TI's applicable warranties or warranty disclaimers for TI products.

Mailing Address: Texas Instruments, Post Office Box 655303, Dallas, Texas 75265
Copyright © 2018, Texas Instruments Incorporated