

# Sealed Lead-Acid Battery Charger

## FEATURES

- Optimum Control for Maximum Battery Capacity and Life
- Internal State Logic Provides Three Charge States
- Precision Reference Tracks Battery Requirements Over Temperature
- Controls Both Voltage and Current at Charger Output
- System Interface Functions
- Typical Standby Supply Current of only 1.6mA

## DESCRIPTION

The UC2906 series of battery charger controllers contains all of the necessary circuitry to optimally control the charge and hold cycle for sealed lead-acid batteries. These integrated circuits monitor and control both the output voltage and current of the charger through three separate charge states; a high current bulk-charge state, a controlled over-charge, and a precision float-charge, or standby, state.

Optimum charging conditions are maintained over an extended temperature range with an internal reference that tracks the nominal temperature characteristics of the lead-acid cell. A typical standby supply current requirement of only 1.6mA allows these ICs to predictably monitor ambient temperatures.

Separate voltage loop and current limit amplifiers regulate the output voltage and current levels in the charger by controlling the onboard driver. The driver will supply at least 25mA of base drive to an external pass device. Voltage and current sense comparators are used to sense the battery condition and respond with logic inputs to the charge state logic. A charge enable comparator with a trickle bias output can be used to implement a low current turn-on mode of the charger, preventing high current charging during abnormal conditions such as a shorted battery cell.

Other features include a supply under-voltage sense circuit with a logic output to indicate when input power is present. In addition the over-charge state of the charger can be externally monitored and terminated using the over-charge indicate output and over-charge terminate input.

## BLOCK DIAGRAM

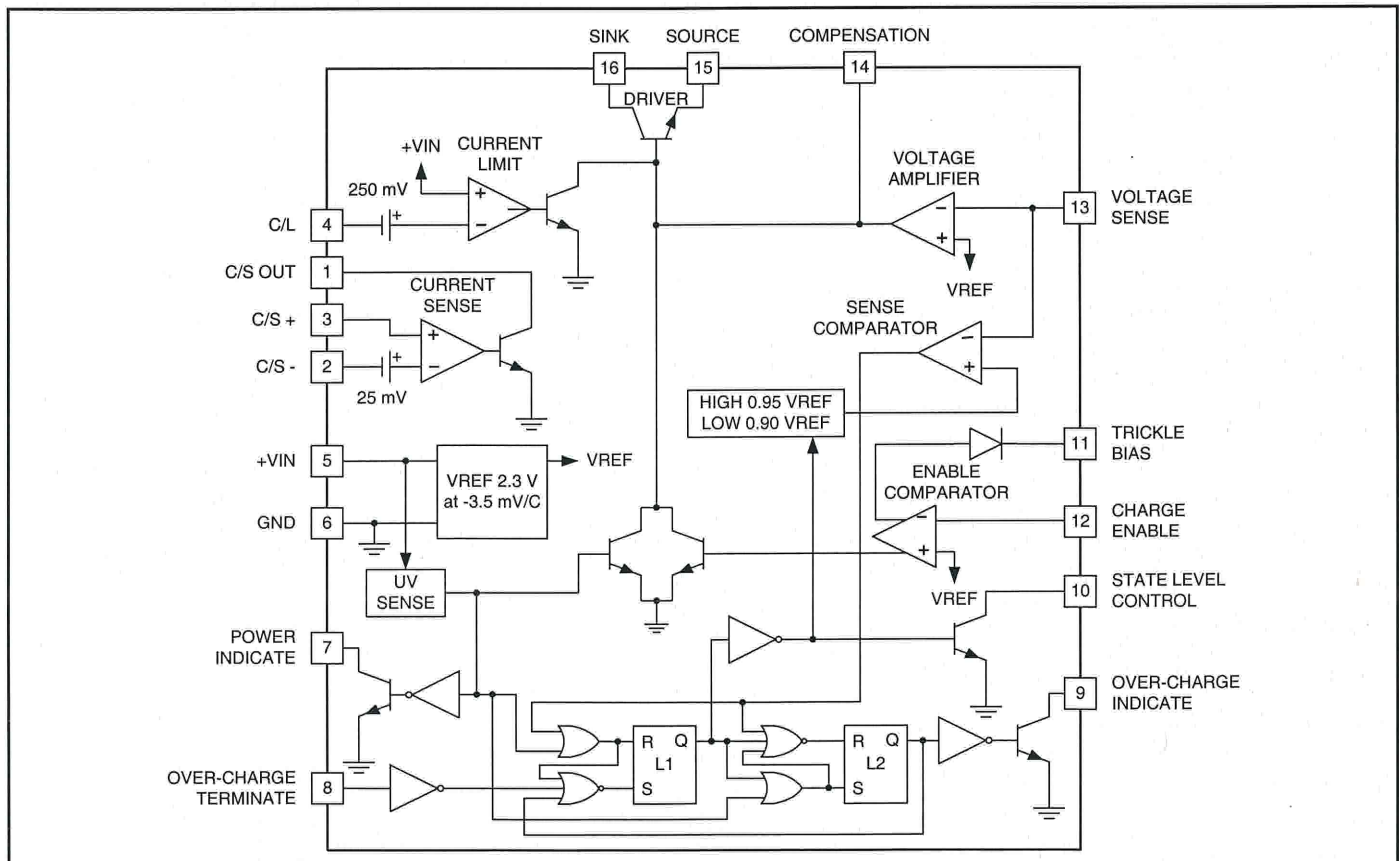

**ABSOLUTE MAXIMUM RATINGS**

Supply Voltage (+VIN) . . . . .	40V
Open Collector Output Voltages . . . . .	40V
Amplifier and Comparator Input Voltages . . . . .	-0.3V to +40V
Over-Charge Terminate Input Voltage . . . . .	-0.3V to +40V
Current Sense Amplifier Output Current. . . . .	80mA
Other Open Collector Output Currents. . . . .	20mA
Trickle Bias Voltage Differential with respect to VIN . . . . .	-32V
Trickle Bias Output Current . . . . .	-40mA
Driver Current. . . . .	80mA
Power Dissipation at TA = 25°C (Note 2). . . . .	1000mW
Power Dissipation at TC = 25°C (Note 2). . . . .	2000mW
Operating Junction Temperature . . . . .	-55°C to +150°C
Storage Temperature . . . . .	-65°C to +150°C
Lead Temperature (Soldering, 10 Seconds) . . . . .	300°C

**Note 1:** Voltages are referenced to ground (Pin 6). Currents are positive into, negative out of, the specified terminals.

**Note 2:** Consult Packaging section of Databook for thermal limitations and considerations of packages.

**CONNECTION DIAGRAMS**

**PLCC-20, LCC-20 (TOP VIEW)  
Q, L Packages**

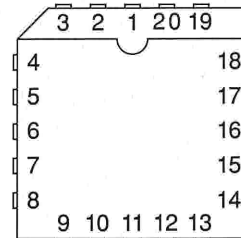

PIN FUNCTION	PIN
N/C	1
C/S OUT	2
C/S-	3
C/S+	4
C/L	5
N/C	6
+VIN	7
GROUND	8
POWER INDICATE	9
OVER CHARGE TERMINATE	10
N/C	11
OVER CHARGE INDICATE	12
STATE LEVEL CONTROL	13
TRICKLE BIAS	14
CHARGE ENABLE	15
N/C	16
VOLTAGE SENSE	17
COMPENSATION	18
DRIVER SOURCE	19
DRIVER SINK	20

**DIL-16, SOIC-16 (TOP VIEW)  
J or N Package, DW Package**

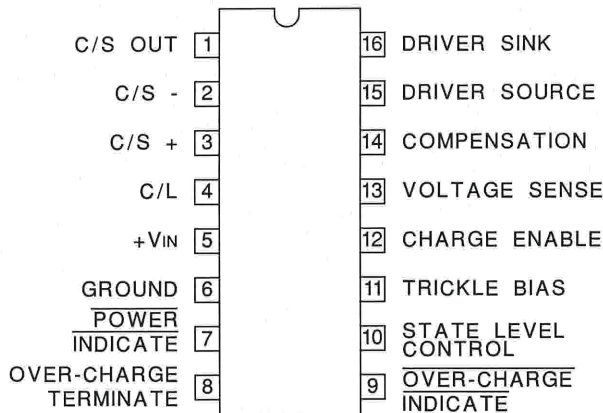

**ELECTRICAL CHARACTERISTICS:** Unless otherwise stated, these specifications apply for TA = -40°C to +70°C for the UC2906 and 0°C to +70°C for the UC3906, +VIN = 10V, TA = TJ.

PARAMETER	TEST CONDITIONS	UC2906			UC3906			UNITS
		MIN	TYP	MAX	MIN	TYP	MAX	
<b>Input Supply</b>								
Supply Current	+VIN = 10V		1.6	3.3		1.6	3.3	mA
	+VIN = 40V		1.8	3.6		1.8	3.6	mA
	+VIN = 40V, TA = -40°C to 85°C		1.8	4				mA
Supply Under-Voltage Threshold	+VIN = Low to High	4.2	4.5	4.8	4.2	4.5	4.8	V
Supply Under-Voltage Hysteresis			0.20	0.30		0.20	0.30	V
<b>Internal Reference (VREF)</b>								
Voltage Level (Note 3)	Measured as Regulating Level at Pin 13 w/ Driver Current = 1mA, TJ = 25°C	2.275	2.3	2.325	2.270	2.3	2.330	V
Line Regulation	+VIN = 5 to 40V		3	8		3	8	mV
Temperature Coefficient			-3.5			-3.5		mV/°C

**ELECTRICAL CHARACTERISTICS:** Unless otherwise stated, these specifications apply for  $T_A = -40^\circ\text{C}$  to  $+70^\circ\text{C}$  for the UC2906 and  $0^\circ\text{C}$  to  $+70^\circ\text{C}$  for the UC3906,  $+V_{IN} = 10\text{V}$ ,  $T_A = T_J$ .

PARAMETER	TEST CONDITIONS	UC2906			UC3906			UNITS
		MIN	TYP	MAX	MIN	TYP	MAX	
<b>Voltage Amplifier</b>								
Input Bias Current	Total Input Bias at Regulating Level	-0.5	-0.2		-0.5	-0.2		$\mu\text{A}$
Maximum Output Current	Source	-45	-30	-15	-45	-30	-15	$\mu\text{A}$
	Sink	30	60	90	30	60	90	$\mu\text{A}$
Open Loop Gain	Driver current = 1mA	50	65		50	65		dB
Output Voltage Swing	Volts above GND or below $+V_{IN}$		0.2			0.2		V
<b>Driver</b>								
Minimum Supply to Source Differential	Pin 16 = $+V_{IN}$ , $I_O = 10\text{mA}$		2.0	2.2		2.0	2.2	V
Maximum Output Current	Pin 16 to Pin 15 = 2V	25	40		25	40		mA
Saturation Voltage			0.2	0.45		0.2	0.45	V
<b>Current Limit Amplifier</b>								
Input Bias Current			0.2	1.0		0.2	1.0	$\mu\text{A}$
Threshold Voltage	Offset below $+V_{IN}$	225	250	275	225	250	275	mV
Threshold Supply Sensitivity	$+V_{IN} = 5$ to $40\text{V}$		0.03	0.25		0.03	0.25	%/V
<b>Voltage Sense Comparator</b>								
Threshold Voltage	As a function of $V_{REF}$ , $L_1 = \text{RESET}$	0.94	0.949	0.960	0.94	0.949	0.960	V/V
	As a function of $V_{REF}$ , $L_1 = \text{SET}$	0.895	0.90	0.910	0.895	0.90	0.910	V/V
Input Bias Current	Total Input Bias at Thresholds	-0.5	-0.2		-0.5	-0.2		$\mu\text{A}$
<b>Current Sense Comparator</b>								
Input Bias Current			0.1	0.5		0.1	0.5	$\mu\text{A}$
Input Offset Current			0.01	0.2		0.01	0.2	$\mu\text{A}$
Input Offset Voltage	Referenced to Pin 2, $I_{OUT} = 1\text{mA}$	20	25	30	20	25	30	mV
Offset Supply Sensitivity	$+V_{IN} = 5$ to $40\text{V}$		0.05	0.35		0.05	0.35	%/V
Offset Common Mode Sensitivity	$\text{CMV} = 2\text{V}$ to $+V_{IN}$		0.05	0.35		0.05	0.35	%/V
Maximum Output Current	$V_{OUT} = 2\text{V}$	25	40		25	40		mA
Output Saturation Voltage	$I_{OUT} = 10\text{mA}$		0.2	0.45		0.2	0.45	V
<b>Enable Comparator</b>								
Threshold Voltage	As a function of $V_{REF}$	0.99	1.0	1.01	0.99	1.0	1.01	V/V
Input Bias Current		-0.5	-0.2		-0.5	-0.2		$\mu\text{A}$
Trickle Bias Maximum Output Current	$V_{OUT} = +V_{IN} - 3\text{V}$	25	40		25	40		mA
Trickle Bias Maximum Output Voltage	Volts below $+V_{IN}$ , $I_{OUT} = 10\text{mA}$		2.0	2.6		2.0	2.6	V
Trickle Bias Reverse Hold-Off Voltage	$+V_{IN} = 0\text{V}$ , $I_{OUT} = -10\mu\text{A}$	6.3	7.0		6.3	7.0		V
<b>Over-Charge Terminate Input</b>								
Threshold Voltage		0.7	1.0	1.3	0.7	1.0	1.3	V
Internal Pull-Up Current	At Threshold		10			10		$\mu\text{A}$
<b>Open Collector Outputs (Pins 7, 9, and 10)</b>								
Maximum Output Current	$V_{OUT} = 2\text{V}$	2.5	5		2.5	5		mA
Saturation Voltage	$I_{OUT} = 1.6\text{mA}$		0.25	0.45		0.25	0.45	V
	$I_{OUT} = 50\mu\text{A}$		0.03	0.05		0.03	0.05	V
Leakage Current	$V_{OUT} = 40\text{V}$		1	3		1	3	$\mu\text{A}$

Note 3. The reference voltage will change as a function of power dissipation on the die according to the temperature coefficient of the reference and the thermal resistance, junction-to-ambient.



OPERATION AND APPLICATION INFORMATION

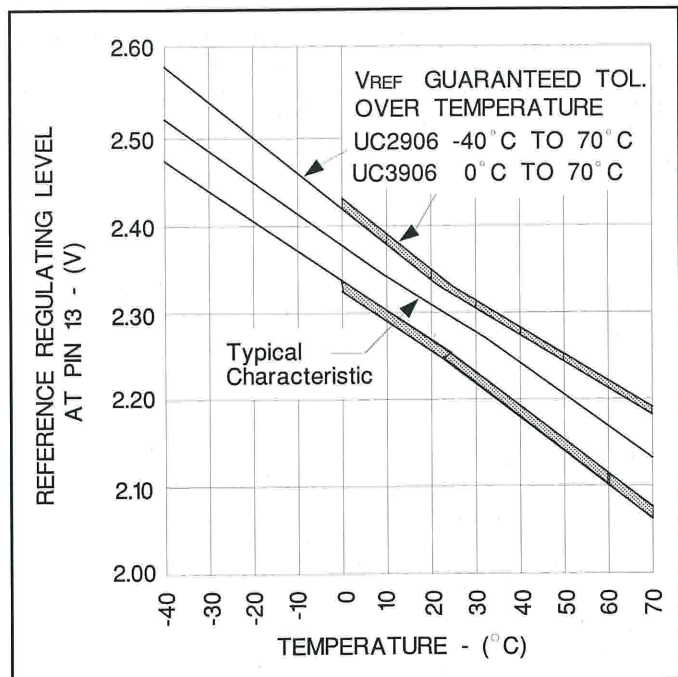

Internal reference temperature characteristic and tolerance.

Dual Level Float Charger Operations

The UC2906 is shown configured as a dual level float charger in Figure 1. All high currents are handled by the external PNP pass transistor with the driver supplying base drive to this device. This scheme uses the TRICKLE BIAS output and the charge enable comparator

to give the charger a low current turn on mode. The output current of the charger is limited to a low-level until the battery reaches a specified voltage, preventing a high current charging if a battery cell is shorted. Figure 2 shows the state diagram of the charger. Upon turn on the UV sense circuitry puts the charger in state 1, the high rate bulk-charge state. In this state, once the enable threshold has been exceeded, the charger will supply a peak current that is determined by the 250mV offset in the C/L amplifier and the sensing resistor  $R_S$ .

To guarantee full re-charge of the battery, the charger's voltage loop has an elevated regulating level,  $V_{OC}$ , during state 1 and state 2. When the battery voltage reaches 95% of  $V_{OC}$ , the charger enters the over-charge state, state 2. The charger stays in this state until the OVER-CHARGE TERMINATE pin goes high. In Figure 1, the charger uses the current sense amplifier to generate this signal by sensing when the charge current has tapered to a specified level,  $I_{OCT}$ . Alternatively the over-charge could have been controlled by an external source, such as a timer, by using the OVER-CHARGE INDICATE signal at Pin 9. If a load is applied to the battery and begins to discharge it, the charger will contribute its full output to the load. If the battery drops 10% below the float level, the charger will reset itself to state 1. When the load is removed a full charge cycle will follow. A graphical representation of a charge, and discharge, cycle of the dual lever float charger is shown in Figure 3.

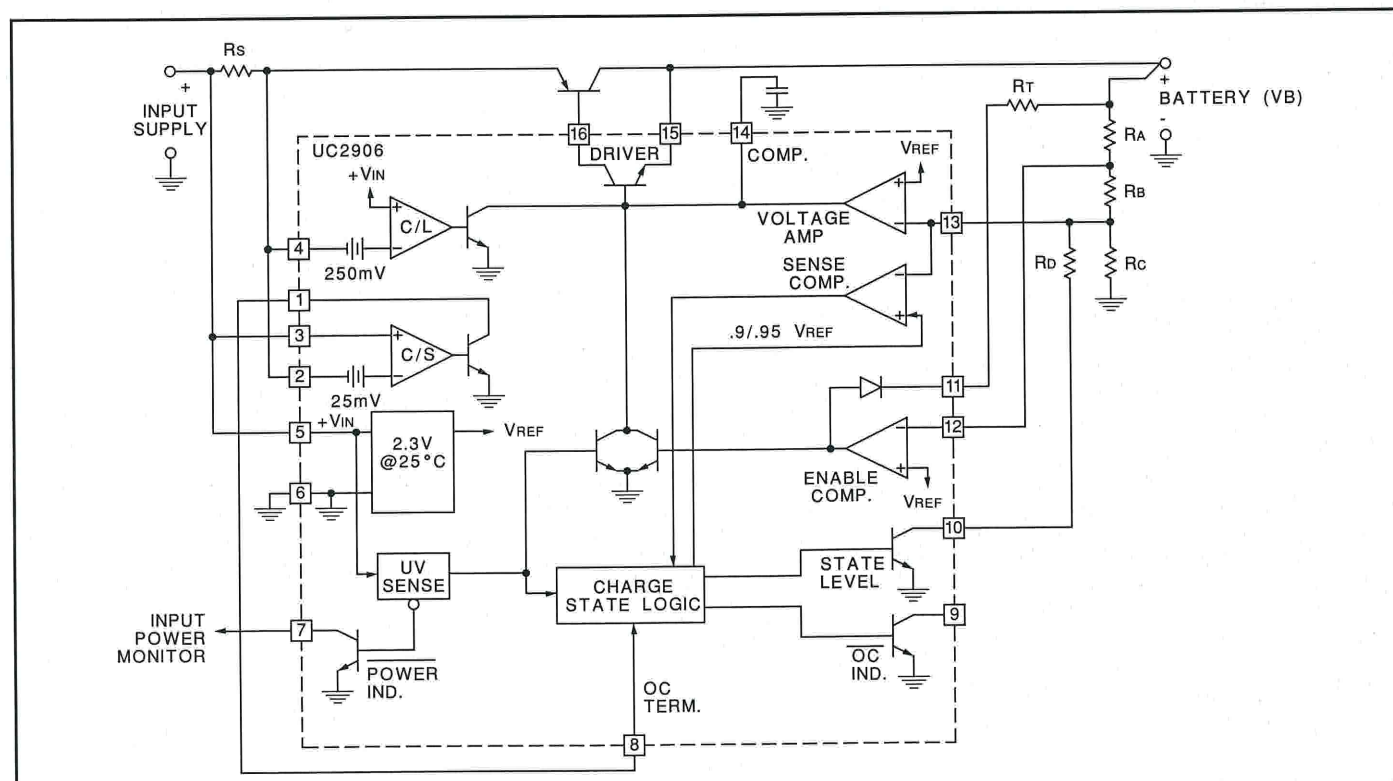

Figure 1. The UC2906 in a dual level float charger.

OPERATION AND APPLICATION INFORMATION (cont.)

**Design Procedure**

1) Pick divider current,  $I_D$ . Recommended value is  $50\mu\text{A}$  to  $100\mu\text{A}$ .

2)  $R_C = 2.3V / I_D$

3)  $R_A + R_B = R_{SUM} = (V_F - 2.3V) / I_D$

4)  $R_D = 2.3V \cdot R_{SUM} / (V_{OC} - V_F)$

5)  $R_A = (R_{SUM} + R_X)(1 - 2.3V / V_T)$   
WHERE:  $R_X = R_C \cdot R_D / (R_C + R_D)$

6)  $R_B = R_{SUM} - R_A$

7)  $R_S = 0.25V / I_{MAX}$

8)  $R_T = (V_{IN} - V_T - 2.5V) / I_T$

9)  $I_{OCT} = \frac{I_{MAX}}{10}$

Note:  $V_{12} = 0.95 V_{OC}$ ,  
 $V_{31} = 0.90 V_F$ ,

For further design and application information see  
UICC Application Note U-104

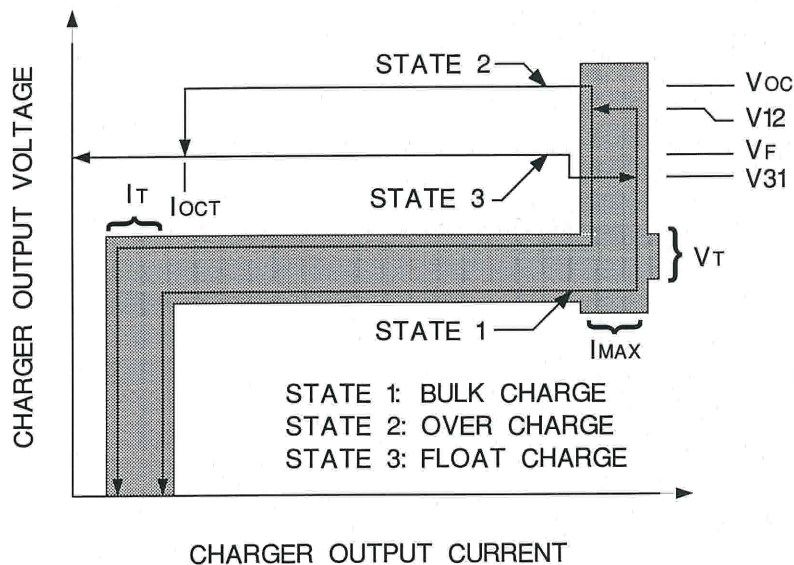
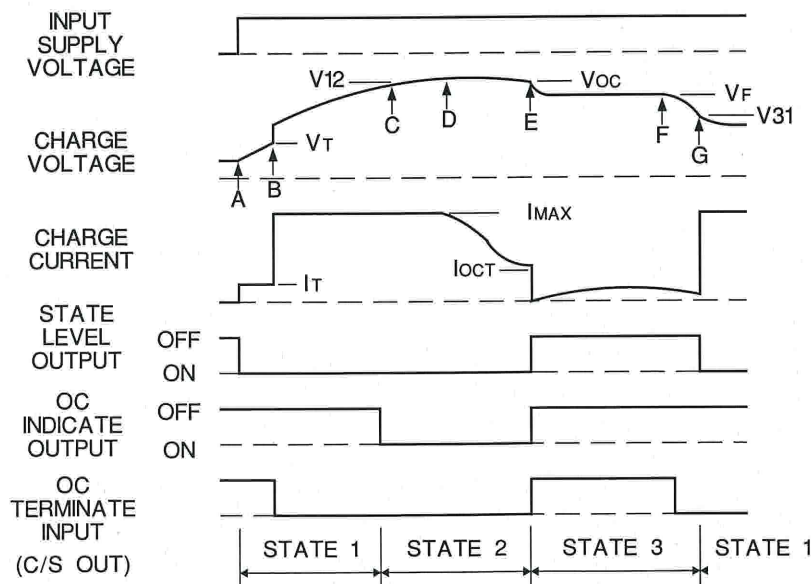

Figure 2. State diagram and design equations for the dual level float charger.



**Explanation: Dual Level Float Charger**

- A. Input power turns on, battery charges at trickle current rate.
- B. Battery voltage reaches  $V_T$  enabling the driver and turning off the trickle bias output, battery charges at  $I_{MAX}$  rate.
- C. Transition voltage  $V_{12}$  is reached and the charger indicates that it is now in the over-charge state, state 2.
- D. Battery voltage approaches the over-charge level  $V_{OC}$  and the charge current begins to taper.
- E. Charge current tapers to  $I_{OCT}$ . The current sense amplifier output, in this case tied to the OC TERMINATE input, goes high. The charger changes to the float state and holds the battery voltage at  $V_F$ .
- F. Here a load ( $>I_{MAX}$ ) begins to discharge the battery.
- G. The load discharges the battery such that the battery voltage falls below  $V_{31}$ . The charger is now in state 1, again.

Figure 3. Typical charge cycle: UC2906 dual level float charger.



## OPERATION AND APPLICATION INFORMATION (cont.)

### Compensated Reference Matches Battery Requirements

When the charger is in the float state, the battery will be maintained at a precise float voltage,  $V_F$ . The accuracy of this float state will maximize the standby life of the battery while the bulk-charge and over-charge states guarantee rapid and full re-charge. All of the voltage thresholds on the UC2906 are derived from the internal reference. This reference has a temperature coefficient that tracks the temperature characteristic of the optimum-charge and hold levels for sealed lead-acid cells. This further guarantees that proper charging occurs, even at temperature extremes.

### Dual Step Current Charger Operation

Figures 4, 5 and 6 illustrate the UC2906's use in a different charging scheme. The dual step current charger is useful when a large string of series cells must be charged. The holding-charge state maintains a slightly elevated voltage across the batteries with the holding current,  $1H$ . This will tend to guarantee equal charge distribution between the cells. The bulk-charge state is similar to that of the float charger with the exception that when  $V_{12}$  is reached, no over-charge state occurs since Pin 8 is tied high at all times. The current sense amplifier is used to regulate the holding current. In some applica-

tions a series resistor, or external buffering transistor, may be required at the current sense output to prevent excessive power dissipation on the UC2906.

### A PNP Pass Device Reduces Minimum Input to Output Differential

The configuration of the driver on the UC2906 allows a good bit of flexibility when interfacing to an external pass transistor. The two chargers shown in Figures 1 and 4 both use PNP pass devices, although an NPN device driven from the source output of the UC2906 driver can also be used. In situations where the charger must operate with low input to output differentials the PNP pass device should be configured as shown in Figure 4. The PNP can be operated in a saturated mode with only the series diode and sense resistor adding to the minimum differential. The series diode, D1, in many applications, can be eliminated. This diode prevents any discharging of the battery, except through the sensing divider, when the charger is attached to the battery with no input supply voltage. If discharging under this condition must be kept to an absolute minimum, the sense divider can be referenced to the POWER INDICATE pin, Pin 7, instead of ground. In this manner the open collector off state of Pin 7 will prevent the divider resistors from discharging the battery when the input supply is removed.

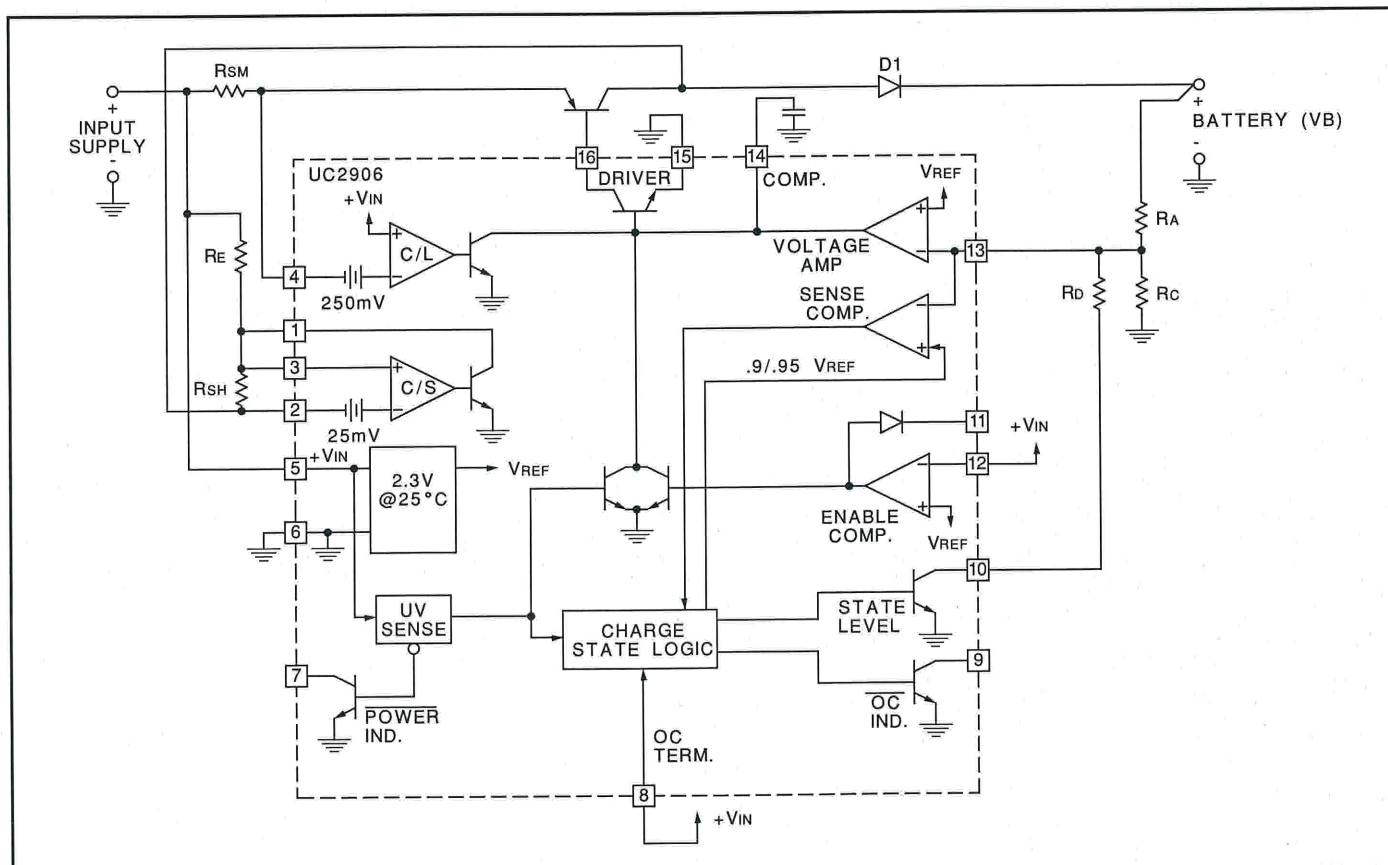

Figure 4. The UC2906 in a dual step current charger.

OPERATION AND APPLICATION INFORMATION (cont.)

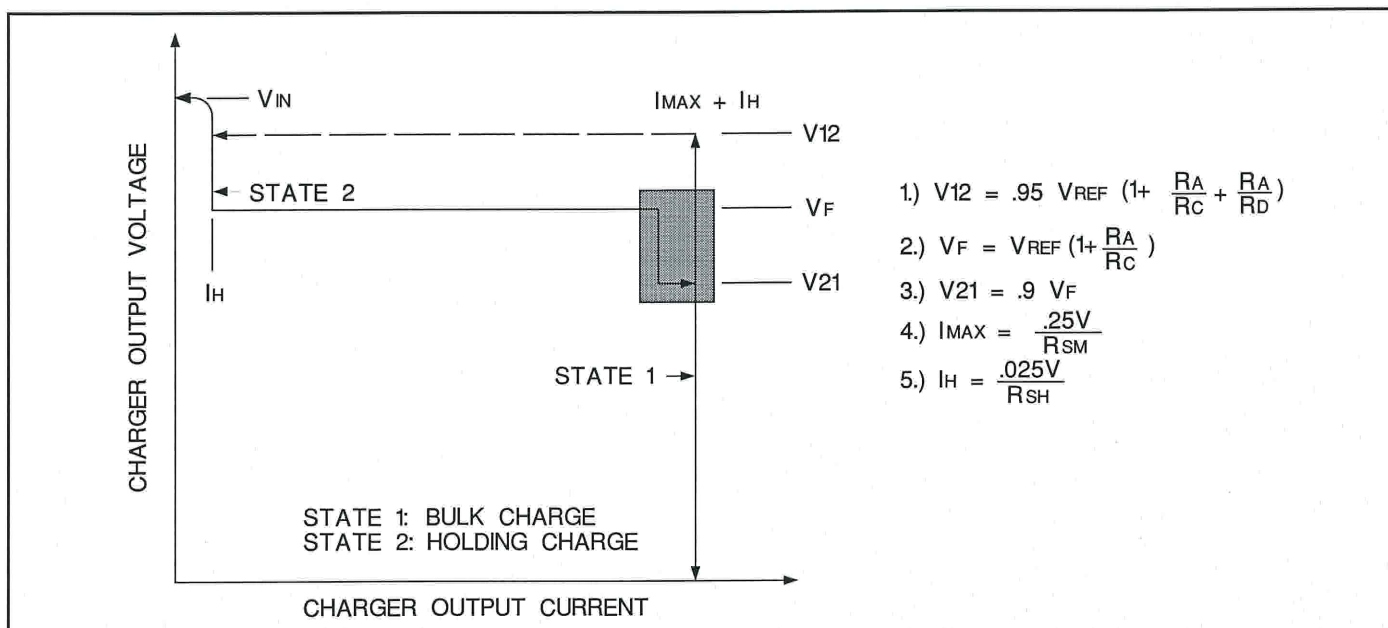
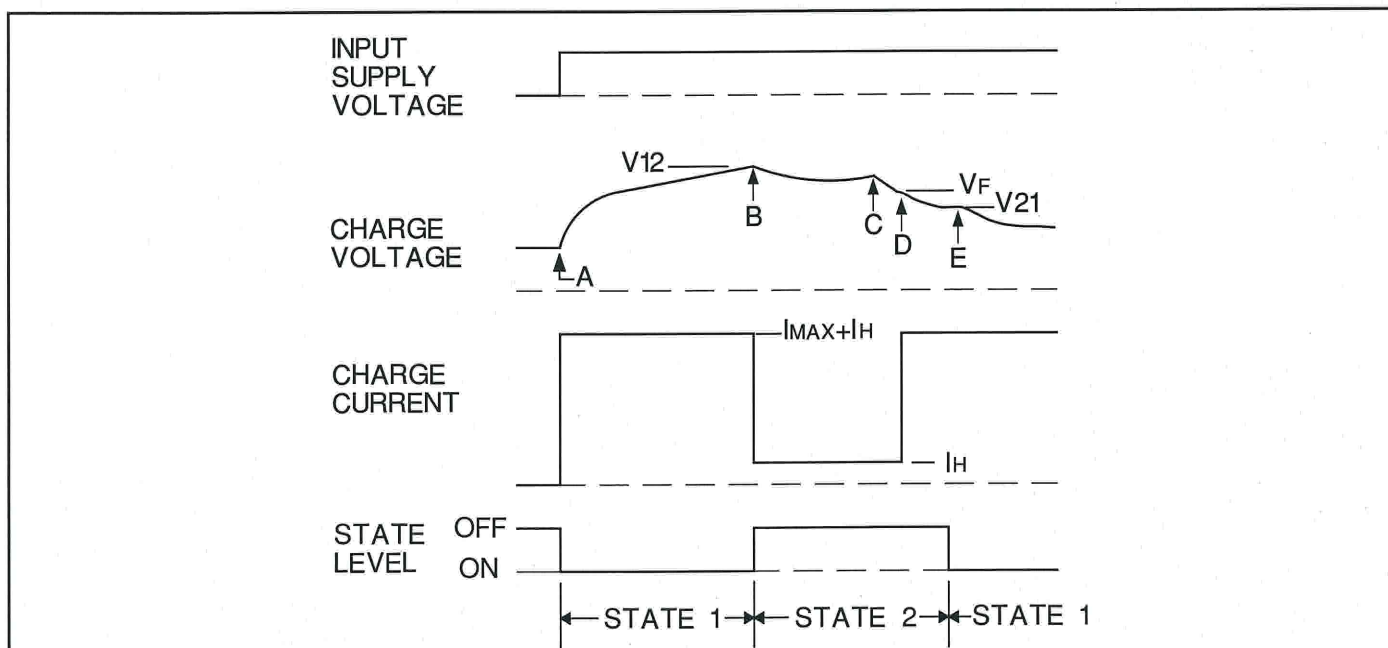

Figure 5. State Diagram and design equations for the dual step current charger.



**Explanation: Dual Step Current Charger**

- |   |  |
|---|--|
| <p>A. Input power turns on, battery charges at a rate of <math>I_H + I_{MAX}</math>.</p> <p>B. Battery voltage reaches <math>V_{12}</math> and the voltage loop switches to the lower level <math>V_F</math>. The battery is now fed with the holding current <math>I_H</math>.</p> | <p>C. An external load starts to discharge the battery.</p> <p>D. When <math>V_F</math> is reached the charger will supply the full current <math>I_{MAX} + I_H</math>.</p> <p>E. The discharge continues and the battery voltage reaches <math>V_{21}</math> causing the charger to switch back to state 1.</p> |
|---|--|

Figure 6. Typical charge cycle: UC2906 dual step current charger

**PACKAGING INFORMATION**

Orderable Device	Status <sup>(1)</sup>	Package Type	Package Drawing	Pins	Package Qty	Eco Plan <sup>(2)</sup>	Lead/Ball Finish	MSL Peak Temp <sup>(3)</sup>
UC2906DW	ACTIVE	SOIC	DW	16	40	Green (RoHS & no Sb/Br)	CU NIPDAU	Level-2-260C-1 YEAR
UC2906DWG4	ACTIVE	SOIC	DW	16	40	Green (RoHS & no Sb/Br)	CU NIPDAU	Level-2-260C-1 YEAR
UC2906DWTR	ACTIVE	SOIC	DW	16	2000	Green (RoHS & no Sb/Br)	CU NIPDAU	Level-2-260C-1 YEAR
UC2906DWTRG4	ACTIVE	SOIC	DW	16	2000	Green (RoHS & no Sb/Br)	CU NIPDAU	Level-2-260C-1 YEAR
UC2906N	ACTIVE	PDIP	N	16	25	Green (RoHS & no Sb/Br)	CU NIPDAU	N / A for Pkg Type
UC2906NG4	ACTIVE	PDIP	N	16	25	Green (RoHS & no Sb/Br)	CU NIPDAU	N / A for Pkg Type
UC2906Q	ACTIVE	PLCC	FN	20	46	Green (RoHS & no Sb/Br)	CU SN	Level-2-260C-1 YEAR
UC2906QG3	ACTIVE	PLCC	FN	20	46	Green (RoHS & no Sb/Br)	CU SN	Level-2-260C-1 YEAR
UC3906DW	ACTIVE	SOIC	DW	16	40	Green (RoHS & no Sb/Br)	CU NIPDAU	Level-2-260C-1 YEAR
UC3906DWG4	ACTIVE	SOIC	DW	16	40	Green (RoHS & no Sb/Br)	CU NIPDAU	Level-2-260C-1 YEAR
UC3906DWTR	ACTIVE	SOIC	DW	16	2000	Green (RoHS & no Sb/Br)	CU NIPDAU	Level-2-260C-1 YEAR
UC3906DWTRG4	ACTIVE	SOIC	DW	16	2000	Green (RoHS & no Sb/Br)	CU NIPDAU	Level-2-260C-1 YEAR
UC3906J	OBSOLETE	CDIP	J	16		TBD	Call TI	Call TI
UC3906N	ACTIVE	PDIP	N	16	25	Green (RoHS & no Sb/Br)	CU NIPDAU	N / A for Pkg Type
UC3906NG4	ACTIVE	PDIP	N	16	25	Green (RoHS & no Sb/Br)	CU NIPDAU	N / A for Pkg Type
UC3906Q	ACTIVE	PLCC	FN	20	46	Green (RoHS & no Sb/Br)	CU SN	Level-2-260C-1 YEAR
UC3906QG3	ACTIVE	PLCC	FN	20	46	Green (RoHS & no Sb/Br)	CU SN	Level-2-260C-1 YEAR
UC3906QTR	ACTIVE	PLCC	FN	20	1000	Green (RoHS & no Sb/Br)	CU SN	Level-2-260C-1 YEAR
UC3906QTRG3	ACTIVE	PLCC	FN	20	1000	Green (RoHS & no Sb/Br)	CU SN	Level-2-260C-1 YEAR

<sup>(1)</sup> The marketing status values are defined as follows:

**ACTIVE:** Product device recommended for new designs.

**LIFEBUY:** TI has announced that the device will be discontinued, and a lifetime-buy period is in effect.

**NRND:** Not recommended for new designs. Device is in production to support existing customers, but TI does not recommend using this part in a new design.

**PREVIEW:** Device has been announced but is not in production. Samples may or may not be available.

**OBSOLETE:** TI has discontinued the production of the device.

<sup>(2)</sup> Eco Plan - The planned eco-friendly classification: Pb-Free (RoHS), Pb-Free (RoHS Exempt), or Green (RoHS & no Sb/Br) - please check <http://www.ti.com/productcontent> for the latest availability information and additional product content details.

**TBD:** The Pb-Free/Green conversion plan has not been defined.

**Pb-Free (RoHS):** TI's terms "Lead-Free" or "Pb-Free" mean semiconductor products that are compatible with the current RoHS requirements for all 6 substances, including the requirement that lead not exceed 0.1% by weight in homogeneous materials. Where designed to be soldered at high temperatures, TI Pb-Free products are suitable for use in specified lead-free processes.



**Pb-Free (RoHS Exempt):** This component has a RoHS exemption for either 1) lead-based flip-chip solder bumps used between the die and package, or 2) lead-based die adhesive used between the die and leadframe. The component is otherwise considered Pb-Free (RoHS compatible) as defined above.

**Green (RoHS & no Sb/Br):** TI defines "Green" to mean Pb-Free (RoHS compatible), and free of Bromine (Br) and Antimony (Sb) based flame retardants (Br or Sb do not exceed 0.1% by weight in homogeneous material)

<sup>(3)</sup> MSL, Peak Temp. -- The Moisture Sensitivity Level rating according to the JEDEC industry standard classifications, and peak solder temperature.

**Important Information and Disclaimer:**The information provided on this page represents TI's knowledge and belief as of the date that it is provided. TI bases its knowledge and belief on information provided by third parties, and makes no representation or warranty as to the accuracy of such information. Efforts are underway to better integrate information from third parties. TI has taken and continues to take reasonable steps to provide representative and accurate information but may not have conducted destructive testing or chemical analysis on incoming materials and chemicals. TI and TI suppliers consider certain information to be proprietary, and thus CAS numbers and other limited information may not be available for release.

In no event shall TI's liability arising out of such information exceed the total purchase price of the TI part(s) at issue in this document sold by TI to Customer on an annual basis.

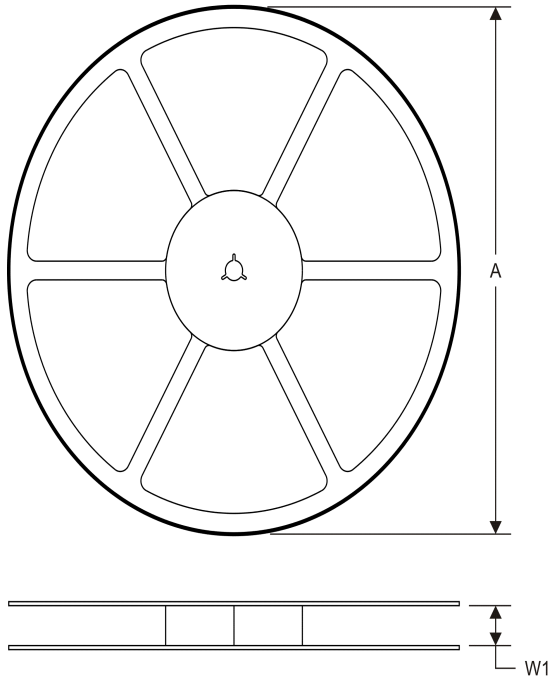
**TAPE AND REEL INFORMATION**
**REEL DIMENSIONS**

**TAPE DIMENSIONS**

A0	Dimension designed to accommodate the component width
B0	Dimension designed to accommodate the component length
K0	Dimension designed to accommodate the component thickness
W	Overall width of the carrier tape
P1	Pitch between successive cavity centers

**TAPE AND REEL INFORMATION**

\*All dimensions are nominal

Device	Package Type	Package Drawing	Pins	SPQ	Reel Diameter (mm)	Reel Width W1 (mm)	A0 (mm)	B0 (mm)	K0 (mm)	P1 (mm)	W (mm)	Pin1 Quadrant
UC2906DWTR	SOIC	DW	16	2000	330.0	16.4	10.75	10.7	2.7	12.0	16.0	Q1
UC3906DWTR	SOIC	DW	16	2000	330.0	16.4	10.75	10.7	2.7	12.0	16.0	Q1
UC3906QTR	PLCC	FN	20	1000	330.0	16.4	10.3	10.3	4.9	12.0	16.0	Q1

## TAPE AND REEL BOX DIMENSIONS



\*All dimensions are nominal

Device	Package Type	Package Drawing	Pins	SPQ	Length (mm)	Width (mm)	Height (mm)
UC2906DWTR	SOIC	DW	16	2000	367.0	367.0	38.0
UC3906DWTR	SOIC	DW	16	2000	367.0	367.0	38.0
UC3906QTR	PLCC	FN	20	1000	367.0	367.0	38.0



J (R-GDIP-T\*\*)

14 LEADS SHOWN

CERAMIC DUAL IN-LINE PACKAGE



DIM \ PINS **	14	16	18	20
A	0.300 (7,62) BSC	0.300 (7,62) BSC	0.300 (7,62) BSC	0.300 (7,62) BSC
B MAX	0.785 (19,94)	.840 (21,34)	0.960 (24,38)	1.060 (26,92)
B MIN	—	—	—	—
C MAX	0.300 (7,62)	0.300 (7,62)	0.310 (7,87)	0.300 (7,62)
C MIN	0.245 (6,22)	0.245 (6,22)	0.220 (5,59)	0.245 (6,22)



4040083/F 03/03

- NOTES:
- A. All linear dimensions are in inches (millimeters).
  - B. This drawing is subject to change without notice.
  - C. This package is hermetically sealed with a ceramic lid using glass frit.
  - D. Index point is provided on cap for terminal identification only on press ceramic glass frit seal only.
  - E. Falls within MIL STD 1835 GDIP1-T14, GDIP1-T16, GDIP1-T18 and GDIP1-T20.

N (R-PDIP-T\*\*)

PLASTIC DUAL-IN-LINE PACKAGE

16 PINS SHOWN



- NOTES:
- A. All linear dimensions are in inches (millimeters).
  - B. This drawing is subject to change without notice.
  - $\triangle C$  Falls within JEDEC MS-001, except 18 and 20 pin minimum body length (Dim A).
  - $\triangle D$  The 20 pin end lead shoulder width is a vendor option, either half or full width.

4040049/E 12/2002

FN (S-PQCC-J\*\*)

PLASTIC J-LEADED CHIP CARRIER

20 PIN SHOWN

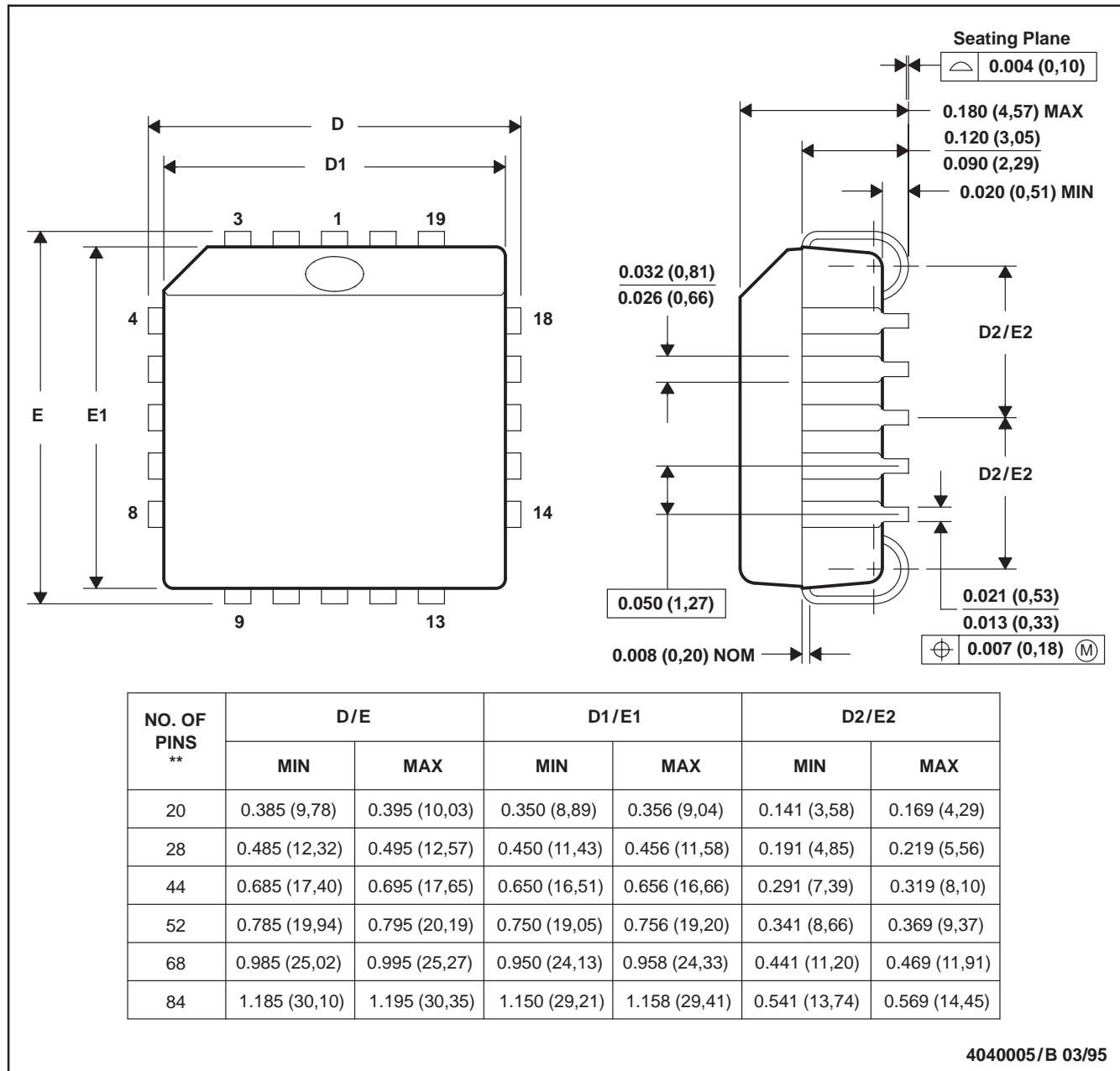

- NOTES: A. All linear dimensions are in inches (millimeters).  
 B. This drawing is subject to change without notice.  
 C. Falls within JEDEC MS-018



DW (R-PDSO-G16)

PLASTIC SMALL OUTLINE



- NOTES:
- A. All linear dimensions are in inches (millimeters). Dimensioning and tolerancing per ASME Y14.5M-1994.
  - B. This drawing is subject to change without notice.
  - C. Body dimensions do not include mold flash or protrusion not to exceed 0.006 (0,15).
  - D. Falls within JEDEC MS-013 variation AA.

DW (R-PDSO-G16)

PLASTIC SMALL OUTLINE

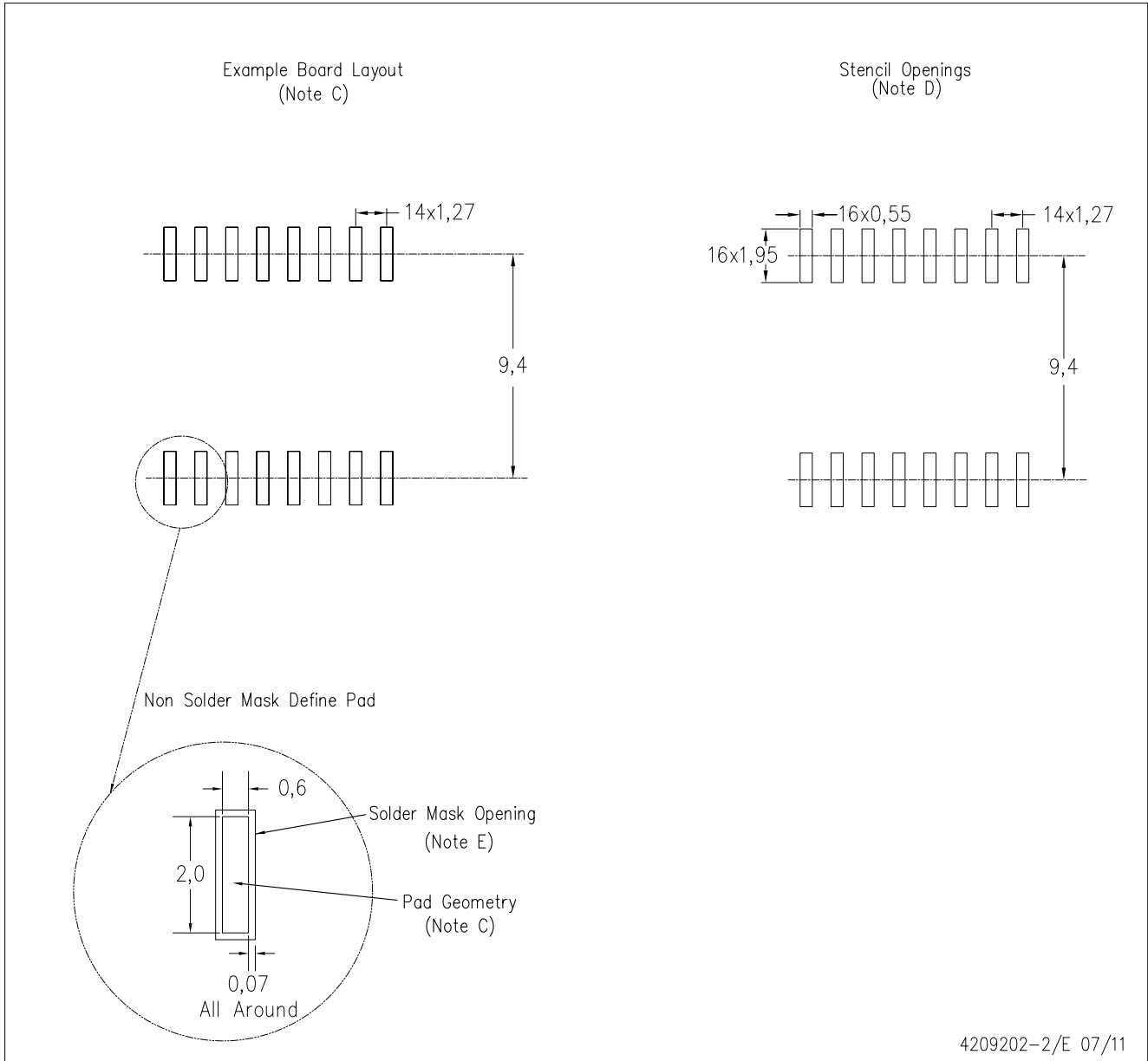

4209202-2/E 07/11

- NOTES:
- A. All linear dimensions are in millimeters.
  - B. This drawing is subject to change without notice.
  - C. Refer to IPC7351 for alternate board design.
  - D. Laser cutting apertures with trapezoidal walls and also rounding corners will offer better paste release. Customers should contact their board assembly site for stencil design recommendations. Refer to IPC-7525
  - E. Customers should contact their board fabrication site for solder mask tolerances between and around signal pads.

## IMPORTANT NOTICE

Texas Instruments Incorporated and its subsidiaries (TI) reserve the right to make corrections, enhancements, improvements and other changes to its semiconductor products and services per JESD46C and to discontinue any product or service per JESD48B. Buyers should obtain the latest relevant information before placing orders and should verify that such information is current and complete. All semiconductor products (also referred to herein as "components") are sold subject to TI's terms and conditions of sale supplied at the time of order acknowledgment.

TI warrants performance of its components to the specifications applicable at the time of sale, in accordance with the warranty in TI's terms and conditions of sale of semiconductor products. Testing and other quality control techniques are used to the extent TI deems necessary to support this warranty. Except where mandated by applicable law, testing of all parameters of each component is not necessarily performed.

TI assumes no liability for applications assistance or the design of Buyers' products. Buyers are responsible for their products and applications using TI components. To minimize the risks associated with Buyers' products and applications, Buyers should provide adequate design and operating safeguards.

TI does not warrant or represent that any license, either express or implied, is granted under any patent right, copyright, mask work right, or other intellectual property right relating to any combination, machine, or process in which TI components or services are used. Information published by TI regarding third-party products or services does not constitute a license to use such products or services or a warranty or endorsement thereof. Use of such information may require a license from a third party under the patents or other intellectual property of the third party, or a license from TI under the patents or other intellectual property of TI.

Reproduction of significant portions of TI information in TI data books or data sheets is permissible only if reproduction is without alteration and is accompanied by all associated warranties, conditions, limitations, and notices. TI is not responsible or liable for such altered documentation. Information of third parties may be subject to additional restrictions.

Resale of TI components or services with statements different from or beyond the parameters stated by TI for that component or service voids all express and any implied warranties for the associated TI component or service and is an unfair and deceptive business practice. TI is not responsible or liable for any such statements.

Buyer acknowledges and agrees that it is solely responsible for compliance with all legal, regulatory and safety-related requirements concerning its products, and any use of TI components in its applications, notwithstanding any applications-related information or support that may be provided by TI. Buyer represents and agrees that it has all the necessary expertise to create and implement safeguards which anticipate dangerous consequences of failures, monitor failures and their consequences, lessen the likelihood of failures that might cause harm and take appropriate remedial actions. Buyer will fully indemnify TI and its representatives against any damages arising out of the use of any TI components in safety-critical applications.

In some cases, TI components may be promoted specifically to facilitate safety-related applications. With such components, TI's goal is to help enable customers to design and create their own end-product solutions that meet applicable functional safety standards and requirements. Nonetheless, such components are subject to these terms.

No TI components are authorized for use in FDA Class III (or similar life-critical medical equipment) unless authorized officers of the parties have executed a special agreement specifically governing such use.

Only those TI components which TI has specifically designated as military grade or "enhanced plastic" are designed and intended for use in military/aerospace applications or environments. Buyer acknowledges and agrees that any military or aerospace use of TI components which have **not** been so designated is solely at the Buyer's risk, and that Buyer is solely responsible for compliance with all legal and regulatory requirements in connection with such use.

TI has specifically designated certain components which meet ISO/TS16949 requirements, mainly for automotive use. Components which have not been so designated are neither designed nor intended for automotive use; and TI will not be responsible for any failure of such components to meet such requirements.

### Products

Audio	<a href="http://www.ti.com/audio">www.ti.com/audio</a>
Amplifiers	<a href="http://amplifier.ti.com">amplifier.ti.com</a>
Data Converters	<a href="http://dataconverter.ti.com">dataconverter.ti.com</a>
DLP® Products	<a href="http://www.dlp.com">www.dlp.com</a>
DSP	<a href="http://dsp.ti.com">dsp.ti.com</a>
Clocks and Timers	<a href="http://www.ti.com/clocks">www.ti.com/clocks</a>
Interface	<a href="http://interface.ti.com">interface.ti.com</a>
Logic	<a href="http://logic.ti.com">logic.ti.com</a>
Power Mgmt	<a href="http://power.ti.com">power.ti.com</a>
Microcontrollers	<a href="http://microcontroller.ti.com">microcontroller.ti.com</a>
RFID	<a href="http://www.ti-rfid.com">www.ti-rfid.com</a>
OMAP Mobile Processors	<a href="http://www.ti.com/omap">www.ti.com/omap</a>
Wireless Connectivity	<a href="http://www.ti.com/wirelessconnectivity">www.ti.com/wirelessconnectivity</a>

### Applications

Automotive and Transportation	<a href="http://www.ti.com/automotive">www.ti.com/automotive</a>
Communications and Telecom	<a href="http://www.ti.com/communications">www.ti.com/communications</a>
Computers and Peripherals	<a href="http://www.ti.com/computers">www.ti.com/computers</a>
Consumer Electronics	<a href="http://www.ti.com/consumer-apps">www.ti.com/consumer-apps</a>
Energy and Lighting	<a href="http://www.ti.com/energy">www.ti.com/energy</a>
Industrial	<a href="http://www.ti.com/industrial">www.ti.com/industrial</a>
Medical	<a href="http://www.ti.com/medical">www.ti.com/medical</a>
Security	<a href="http://www.ti.com/security">www.ti.com/security</a>
Space, Avionics and Defense	<a href="http://www.ti.com/space-avionics-defense">www.ti.com/space-avionics-defense</a>
Video and Imaging	<a href="http://www.ti.com/video">www.ti.com/video</a>

**TI E2E Community** [e2e.ti.com](http://e2e.ti.com)