

High Performance Stepper Motor Drive Circuit

FEATURES

- Full-Step, Half-Step and Micro-Step Capability.
- Bipolar Output Current up to 2A.
- Wide Range of Motor Supply Voltage: 10–50V
- Low Saturation Voltage
- Wide Range of Current Control: 5mA–2A.
- Current Levels Selected in Steps or Varied Continuously.
- Thermal Protection and Soft Intervention.

DESCRIPTION

The UC3770A and UC3770B are high-performance full bridge drivers that offer higher current and lower saturation voltage than the UC3717 and the UC3770. Included in these devices are LS-TTL compatible logic inputs, current sense, monostable, thermal shut-down, and a power H-bridge output stage. Two UC3770As or UC3770Bs and a few external components form a complete micro-processor-controllable stepper motor power system.

Unlike the UC3717, the UC3770A and the UC3770B require external high-side clamp diodes. The UC3770A and UC3770B are identical in all regards except for the current sense thresholds. Thresholds for the UC3770A are identical to those of the older UC3717 permitting drop-in replacement in applications where high-side diodes are not required. Thresholds for the UC3770B are tailored for half stepping applications where 50%, 71%, and 100% current levels are desirable.

The UC3770A and UC3770B are specified for operation from 0°C to 70°C ambient.

BLOCK DIAGRAM

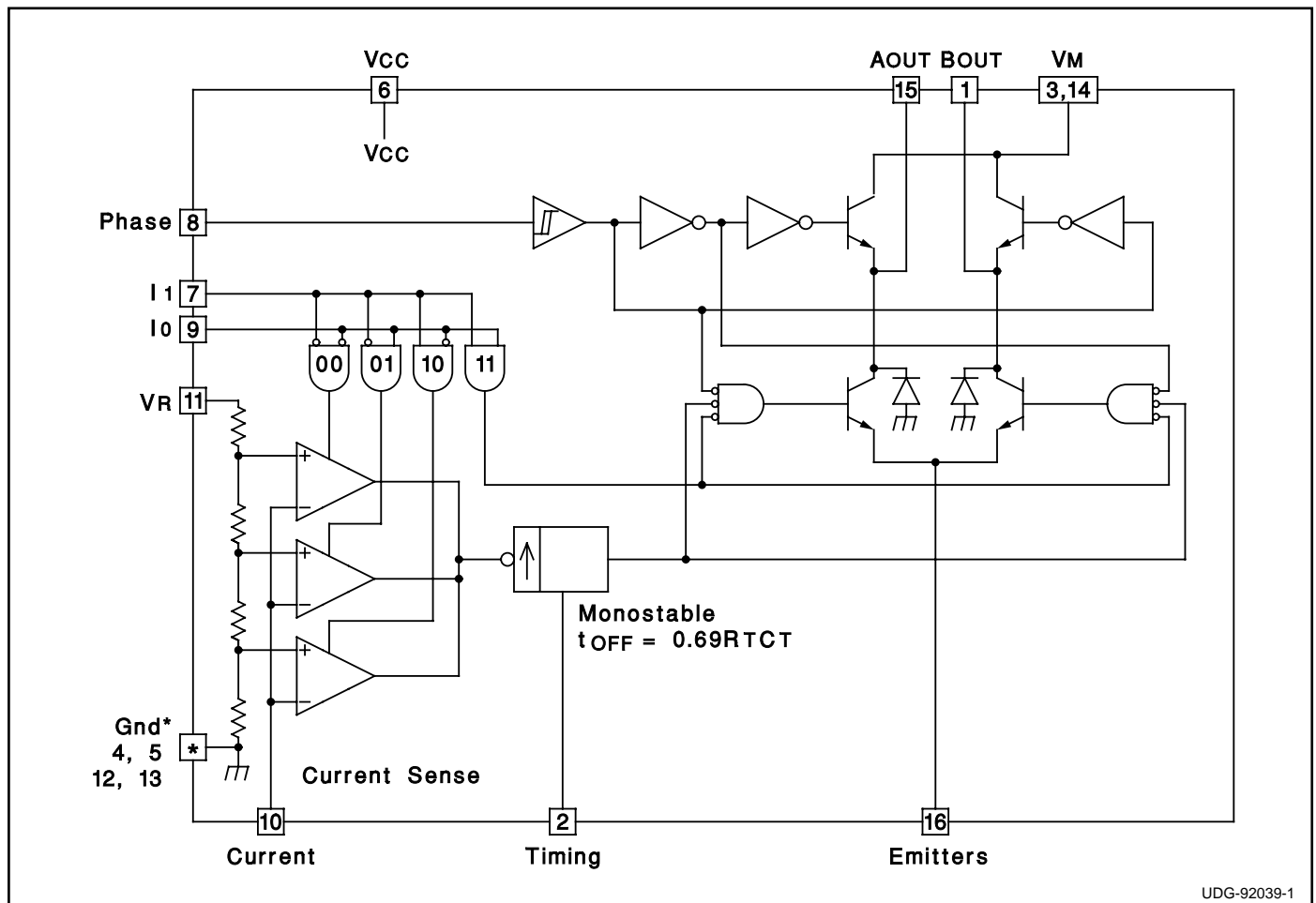

ABSOLUTE MAXIMUM RATINGS

Logic Supply Voltage, Vcc	7V
Output Supply Voltage, VMM	50V
Logic Input Voltage (Pins 7, 8, 9)	6V
Analog Input Voltage (Pin 10)	Vcc
Reference Input Voltage (Pin 11)	15V
Logic Input Current (Pins 7, 8, 9)	-10mA
Analog Input Current (Pins 10, 11)	-10mA
Output Current (Pins 1, 15)	±2A
Junction Temperature, Tj	+150°C

Note 1: All voltages are with respect to Gnd (DIL Pins 4, 5, 12, 13); all currents are positive into, negative out of the specified terminal.

Note 2: Consult Unitrode Integrated Circuits databook for thermal limitations and considerations of packages.

CONNECTION DIAGRAMS

DIL-16 (Top View)
J Or N Package

PLCC-28 (Top View)
Q Package

PACKAGE PIN FUNCTION	
FUNCTION	PIN
Gnd	1-3
VM	4
N/C	5
AOUT	6
N/C	7
Emitters	8
Gnd	9
BOUT	10
Timing	11
VM	12
Gnd	13-17
Vcc	18
I1	19
Phase	20
Io	21
N/C	22
Current	23
VR	24
N/C	25-27
Gnd	28

ELECTRICAL CHARACTERISTICS: (All tests apply with VM = 36V, Vcc = 5V, VR = 5V, No Load, and 0°C < TA < 70°C, unless otherwise stated, TA = Tj.)

PARAMETER	TEST CONDITIONS	UC3770A			UC3770B			UNITS
		MIN	TYP	MAX	MIN	TYP	MAX	
Supply Voltage VM (Pins 3, 14)		10		45	10		45	V
Logic Supply Voltage Vcc (Pin 6)		4.75	5	5.3	4.75	5	5.3	V
Logic Supply Current Icc (Pin 6)	Io = I1 = H, Im = 0		15	25		15	25	mA
	Io = I1 = L, Im = 0		18	28		18	28	mA
	Io = I1 = H, Im = 1.3A		33	40		33	40	mA
Thermal Shutdown Temperature			+170			+170		°C
Logic Threshold (Pins 7, 8, 9)		0.8		2.0	0.8		2.0	V
Input Current Low (Pin 8)	Vi = 0.4V			-100			-100	µA
Input Current Low (Pins 7, 9)	Vi = 0.4V			-400			-400	µA
Input Current High (Pins 7, 8, 9)	Vi = 2.4V			10			10	µA
Comparator Threshold (Pin 10)	VR = 5V, Io = L, I1 = L	400	415	430	400	415	430	mV
	VR = 5V, Io = H, I1 = L	240	255	265	290	300	315	mV
	VR = 5V, Io = L, I1 = H	70	80	90	195	210	225	mV
Comparator Input Current (Pin 10)				±20			±20	µA
Off Time	RT = 56k, CT = 820pF	25	30	35	25	30	35	ms

ELECTRICAL CHARACTERISTICS (cont.): (All tests apply with $V_M = 36V$, $V_{CC} = 5V$, $V_R = 5V$, No Load, and $0^\circ C < T_A < 70^\circ C$, unless otherwise stated, $T_A = T_J$.)

PARAMETER	TEST CONDITIONS	UC3770A			UC3770B			UNITS
		MIN	TYP	MAX	MIN	TYP	MAX	
Turn Off Delay				2			2	ms
Sink Driver Saturation Voltage	$I_M = 1.0A$			0.8			0.8	V
	$I_M = 1.3A$			1.3			1.3	V
Source Driver Saturation Voltage	$I_M = 1.0A$			1.3			1.3	V
	$I_M = 1.3A$			1.6			1.6	V
Output Leakage Current	$V_M = 45V$			100			100	μA

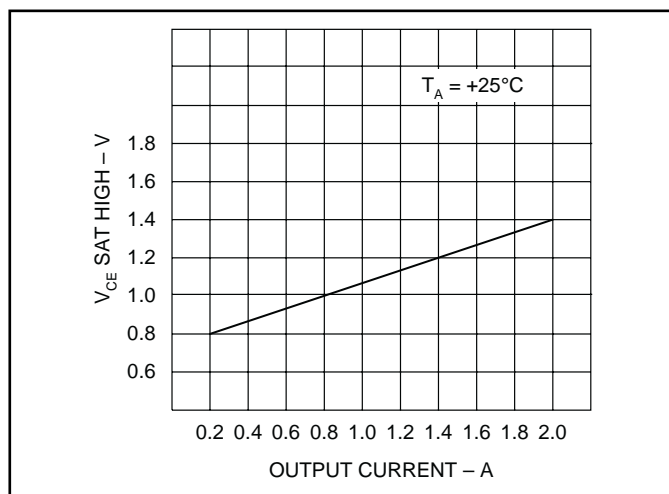

Figure 1. Typical source saturation voltages vs. load current

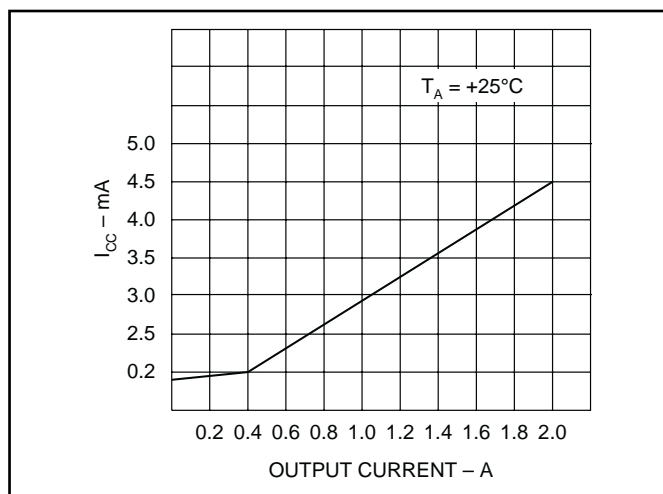

Figure 3. Typical supply current vs. load current.

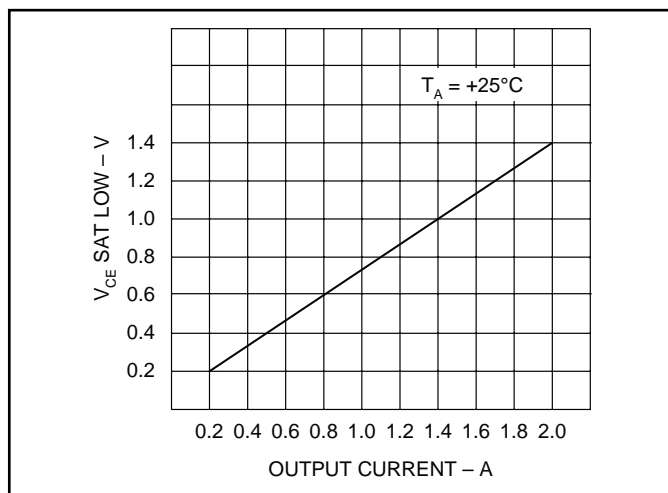

Figure 2. Typical sink saturation voltages vs. load current

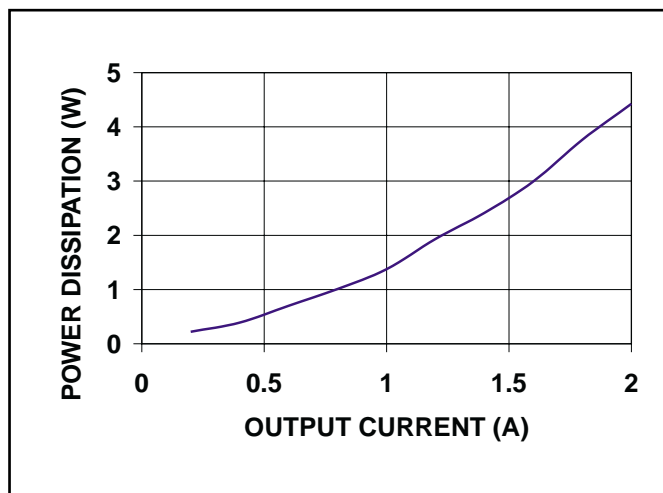

Figure 4. Typical power dissipation vs. output current.

PACKAGING INFORMATION

Orderable Device	Status (1)	Package Type	Package Drawing	Pins	Package Qty	Eco Plan (2)	Lead/Ball Finish	MSL Peak Temp (3)	Op Temp (°C)	Device Marking (4/5)	Samples
UC3770AN	ACTIVE	PDIP	N	16	25	Green (RoHS & no Sb/Br)	CU NIPDAU	N / A for Pkg Type	0 to 70	UC3770AN	Samples
UC3770ANG4	ACTIVE	PDIP	N	16	25	Green (RoHS & no Sb/Br)	CU NIPDAU	N / A for Pkg Type	0 to 70	UC3770AN	Samples
UC3770AQ	ACTIVE	PLCC	FN	28	37	Green (RoHS & no Sb/Br)	CU NIPDAU	Level-3-260C-168 HR	0 to 70	UC3770AQ	Samples
UC3770AQTR	ACTIVE	PLCC	FN	28	750	TBD	Call TI	Call TI	0 to 70	UC3770AQ	Samples
UC3770BN	ACTIVE	PDIP	N	16	25	Green (RoHS & no Sb/Br)	CU NIPDAU	N / A for Pkg Type	0 to 70	UC3770BN	Samples
UC3770BNG4	ACTIVE	PDIP	N	16	25	Green (RoHS & no Sb/Br)	CU NIPDAU	N / A for Pkg Type	0 to 70	UC3770BN	Samples

(1) The marketing status values are defined as follows:

ACTIVE: Product device recommended for new designs.

LIFEBUY: TI has announced that the device will be discontinued, and a lifetime-buy period is in effect.

NRND: Not recommended for new designs. Device is in production to support existing customers, but TI does not recommend using this part in a new design.

PREVIEW: Device has been announced but is not in production. Samples may or may not be available.

OBSOLETE: TI has discontinued the production of the device.

(2) Eco Plan - The planned eco-friendly classification: Pb-Free (RoHS), Pb-Free (RoHS Exempt), or Green (RoHS & no Sb/Br) - please check <http://www.ti.com/productcontent> for the latest availability information and additional product content details.

TBD: The Pb-Free/Green conversion plan has not been defined.

Pb-Free (RoHS): TI's terms "Lead-Free" or "Pb-Free" mean semiconductor products that are compatible with the current RoHS requirements for all 6 substances, including the requirement that lead not exceed 0.1% by weight in homogeneous materials. Where designed to be soldered at high temperatures, TI Pb-Free products are suitable for use in specified lead-free processes.

Pb-Free (RoHS Exempt): This component has a RoHS exemption for either 1) lead-based flip-chip solder bumps used between the die and package, or 2) lead-based die adhesive used between the die and leadframe. The component is otherwise considered Pb-Free (RoHS compatible) as defined above.

Green (RoHS & no Sb/Br): TI defines "Green" to mean Pb-Free (RoHS compatible), and free of Bromine (Br) and Antimony (Sb) based flame retardants (Br or Sb do not exceed 0.1% by weight in homogeneous material)

(3) MSL, Peak Temp. -- The Moisture Sensitivity Level rating according to the JEDEC industry standard classifications, and peak solder temperature.

(4) There may be additional marking, which relates to the logo, the lot trace code information, or the environmental category on the device.

(5) Multiple Device Markings will be inside parentheses. Only one Device Marking contained in parentheses and separated by a "-" will appear on a device. If a line is indented then it is a continuation of the previous line and the two combined represent the entire Device Marking for that device.

Important Information and Disclaimer: The information provided on this page represents TI's knowledge and belief as of the date that it is provided. TI bases its knowledge and belief on information provided by third parties, and makes no representation or warranty as to the accuracy of such information. Efforts are underway to better integrate information from third parties. TI has taken and continues to take reasonable steps to provide representative and accurate information but may not have conducted destructive testing or chemical analysis on incoming materials and chemicals. TI and TI suppliers consider certain information to be proprietary, and thus CAS numbers and other limited information may not be available for release.

In no event shall TI's liability arising out of such information exceed the total purchase price of the TI part(s) at issue in this document sold by TI to Customer on an annual basis.

IMPORTANT NOTICE

Texas Instruments Incorporated and its subsidiaries (TI) reserve the right to make corrections, enhancements, improvements and other changes to its semiconductor products and services per JESD46, latest issue, and to discontinue any product or service per JESD48, latest issue. Buyers should obtain the latest relevant information before placing orders and should verify that such information is current and complete. All semiconductor products (also referred to herein as "components") are sold subject to TI's terms and conditions of sale supplied at the time of order acknowledgment.

TI warrants performance of its components to the specifications applicable at the time of sale, in accordance with the warranty in TI's terms and conditions of sale of semiconductor products. Testing and other quality control techniques are used to the extent TI deems necessary to support this warranty. Except where mandated by applicable law, testing of all parameters of each component is not necessarily performed.

TI assumes no liability for applications assistance or the design of Buyers' products. Buyers are responsible for their products and applications using TI components. To minimize the risks associated with Buyers' products and applications, Buyers should provide adequate design and operating safeguards.

TI does not warrant or represent that any license, either express or implied, is granted under any patent right, copyright, mask work right, or other intellectual property right relating to any combination, machine, or process in which TI components or services are used. Information published by TI regarding third-party products or services does not constitute a license to use such products or services or a warranty or endorsement thereof. Use of such information may require a license from a third party under the patents or other intellectual property of the third party, or a license from TI under the patents or other intellectual property of TI.

Reproduction of significant portions of TI information in TI data books or data sheets is permissible only if reproduction is without alteration and is accompanied by all associated warranties, conditions, limitations, and notices. TI is not responsible or liable for such altered documentation. Information of third parties may be subject to additional restrictions.

Resale of TI components or services with statements different from or beyond the parameters stated by TI for that component or service voids all express and any implied warranties for the associated TI component or service and is an unfair and deceptive business practice. TI is not responsible or liable for any such statements.

Buyer acknowledges and agrees that it is solely responsible for compliance with all legal, regulatory and safety-related requirements concerning its products, and any use of TI components in its applications, notwithstanding any applications-related information or support that may be provided by TI. Buyer represents and agrees that it has all the necessary expertise to create and implement safeguards which anticipate dangerous consequences of failures, monitor failures and their consequences, lessen the likelihood of failures that might cause harm and take appropriate remedial actions. Buyer will fully indemnify TI and its representatives against any damages arising out of the use of any TI components in safety-critical applications.

In some cases, TI components may be promoted specifically to facilitate safety-related applications. With such components, TI's goal is to help enable customers to design and create their own end-product solutions that meet applicable functional safety standards and requirements. Nonetheless, such components are subject to these terms.

No TI components are authorized for use in FDA Class III (or similar life-critical medical equipment) unless authorized officers of the parties have executed a special agreement specifically governing such use.

Only those TI components which TI has specifically designated as military grade or "enhanced plastic" are designed and intended for use in military/aerospace applications or environments. Buyer acknowledges and agrees that any military or aerospace use of TI components which have **not** been so designated is solely at the Buyer's risk, and that Buyer is solely responsible for compliance with all legal and regulatory requirements in connection with such use.

TI has specifically designated certain components as meeting ISO/TS16949 requirements, mainly for automotive use. In any case of use of non-designated products, TI will not be responsible for any failure to meet ISO/TS16949.

Products

Audio	www.ti.com/audio
Amplifiers	amplifier.ti.com
Data Converters	dataconverter.ti.com
DLP® Products	www.dlp.com
DSP	dsp.ti.com
Clocks and Timers	www.ti.com/clocks
Interface	interface.ti.com
Logic	logic.ti.com
Power Mgmt	power.ti.com
Microcontrollers	microcontroller.ti.com
RFID	www.ti-rfid.com
OMAP Applications Processors	www.ti.com/omap
Wireless Connectivity	www.ti.com/wirelessconnectivity

Applications

Automotive and Transportation	www.ti.com/automotive
Communications and Telecom	www.ti.com/communications
Computers and Peripherals	www.ti.com/computers
Consumer Electronics	www.ti.com/consumer-apps
Energy and Lighting	www.ti.com/energy
Industrial	www.ti.com/industrial
Medical	www.ti.com/medical
Security	www.ti.com/security
Space, Avionics and Defense	www.ti.com/space-avionics-defense
Video and Imaging	www.ti.com/video

TI E2E Community

e2e.ti.com