



# SWITCHMODE LEAD-ACID BATTERY CHARGER

 Check for Samples: [UC2909-EP](#)

## FEATURES

- Accurate and Efficient Control of Battery Charging
- Average Current Mode Control from Trickle to Overcharge
- Resistor Programmable Charge Currents
- Thermistor Interface Tracks Battery Requirements Over Temperature
- Output Status Bits Report on Four Internal Charge States
- Undervoltage Lockout Monitors VCC and VREF

## SUPPORTS DEFENSE, AEROSPACE, AND MEDICAL APPLICATIONS

- Controlled Baseline
- One Assembly/Test Site
- One Fabrication Site
- Available in Military (–55°C/125°C) Temperature Range<sup>(1)</sup>
- Extended Product Life Cycle
- Extended Product-Change Notification
- Product Traceability
- Not to Exceed 185.35-KHz Oscillation Frequency at 125°C

(1) Additional temperature ranges available - contact factory

## DESCRIPTION

The UC2909 controls lead acid battery charging with a highly efficient average current mode control loop. This chip combines charge state logic with average current PWM control circuitry. Charge state logic commands current or voltage control depending on the charge state. The chip includes undervoltage lockout circuitry to insure sufficient supply voltage is present before output switching starts. Additional circuit blocks include a differential current sense amplifier, a 1.5% voltage reference, a –3.9-mV/°C thermistor linearization circuit, voltage and current error amplifiers, a PWM oscillator, a PWM comparator, a PWM latch, charge state decode bits, and a 100-mA open collector output driver.

## FUNCTION BLOCK DIAGRAM

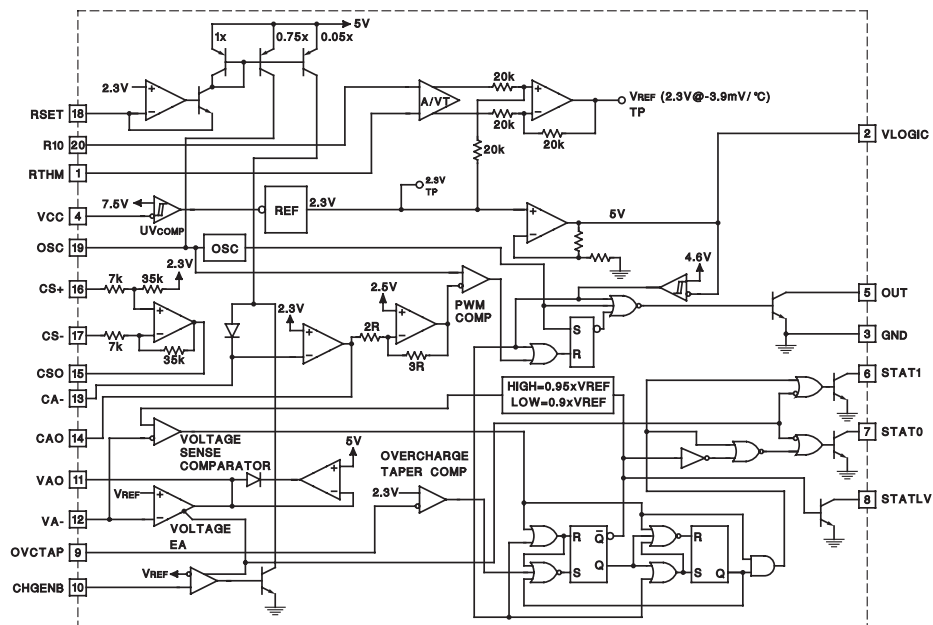

Please be aware that an important notice concerning availability, standard warranty, and use in critical applications of Texas Instruments semiconductor products and disclaimers thereto appears at the end of this data sheet.



This integrated circuit can be damaged by ESD. Texas Instruments recommends that all integrated circuits be handled with appropriate precautions. Failure to observe proper handling and installation procedures can cause damage.

ESD damage can range from subtle performance degradation to complete device failure. Precision integrated circuits may be more susceptible to damage because very small parametric changes could cause the device not to meet its published specifications.

**ORDERING INFORMATION<sup>(1)</sup>**

T <sub>A</sub>	PACKAGE <sup>(2)</sup>	ORDERABLE PART NUMBER	TOP-SIDE MARKING
-55°C to 125°C	DW	UC2909MDWREP	UC2909EP

- (1) For the most current package and ordering information, see the Package Option Addendum at the end of this document, or see the TI Web site at [www.ti.com](http://www.ti.com).
- (2) Package drawings, standard packing quantities, thermal data, symbolization, and PCB design guidelines are available at [www.ti.com/sc/package](http://www.ti.com/sc/package).

**ABSOLUTE MAXIMUM RATINGS<sup>(1) (2)</sup>**

over operating free-air temperature range unless otherwise noted

			UNITS
VCC	Supply voltage	OUT, STAT0, STAT1	40 V
	Output current sink		0.1 A
	CS+, CS-		-0.4 to V <sub>CC</sub> <sup>(3)</sup> V
	Remaining pin voltages		-0.3 to 9 V
T <sub>stg</sub>	Storage temperature		-55 to 150 °C
T <sub>J</sub>	Junction temperature range		-55 to 150 °C
	Lead temperature (soldering, 10 seconds)		300 °C

- (1) Stresses beyond those listed under "absolute maximum ratings" may cause permanent damage to the device. These are stress ratings only, and functional operation of the device at these or any other conditions beyond those indicated under "recommended operating conditions" is not implied. Exposure to absolute-maximum-rated conditions for extended periods may affect device reliability. All voltage values are with respect to the network ground terminal unless otherwise noted.
- (2) All currents are positive into, negative out of the specified terminal. Consult Packaging Section of Databook for thermal limitations and considerations of packages.
- (3) Voltages more negative than -0.4 V can be tolerated if current is limited to 50 mA.

**DW PACKAGE  
(TOP VIEW)**

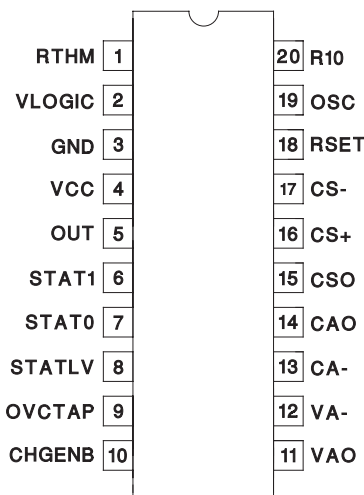

## ELECTRICAL CHARACTERISTICS

$T_A = -55^\circ\text{C}$  to  $125^\circ\text{C}$ ;  $C_T = 430$  pF,  $R_{SET} = 11.5$  k $\Omega$ ,  $R_{10} = 10$  k $\Omega$ ,  $R_{THM} = 10$  k $\Omega$ ,  $V_{CC} = 15$  V, Output no load,  $R_{STAT0} = R_{STAT1} = 10$  k $\Omega$ ,  $CHGENB = OVCTAP = V_{LOGIC}$ ,  $T_A = T_J$  (unless otherwise noted)

PARAMETER	TEST CONDITIONS	MIN	TYP	MAX	UNIT		
<b>CURRENT SENSE AMPLIFIER (CSA) (<math>V_{ID} = CS+ - CS-</math>)</b>							
DC gain	$CS- = 0$ V, $CS+ = -50$ mV; $CS+ = -200$ mV	4.8	5	5.7	V/V		
	$CS+ = 0$ V, $CS- = 50$ mV; $CS- = 250$ mV	4.8	5	5.1			
$V_{OFFSET}$	Offset voltage ( $V_{CSO} - V_{CAO}$ )	$CS+ = CS- = 2.3$ V, $CAO = CA-$			45	mV	
CMRR	$V_{CM} = -0.2$ V to $V_{CC} - 2$ , $8.8$ V < $V_{CC} < 14$ V	50			dB		
	$V_{CM} = -0.2$ V to $V_{CC}$ , $14$ V < $V_{CC} < 35$ V	50					
$V_{OL}$	$V_{ID} = -550$ mV, $-0.2$ V < $V_{CM} < V_{CC} - 2$ , $I_O = 500$ $\mu$ A	0.3			0.6	V	
$V_{OH}$	$V_{ID} = 700$ mV, $-0.2$ V < $V_{CM} < V_{CC} - 2$ , $I_O = -250$ $\mu$ A	5.2	5.7	6.2	V		
	Output source current	$V_{ID} = 700$ mV, $CSO = 4$ V			-1	-0.5	mA
	Output sink current	$V_{ID} = -550$ mV, $CSO = 1$ V			3	4.5	mA
	3dB bandwidth <sup>(1)</sup>	$V_{ID} = 90$ mV, $V_{CM} = 0$ V			200		KHz
<b>CURRENT ERROR AMPLIFIER (CEA)</b>							
$I_B$	$8.8$ V < $V_{CC} < 35$ V, $V_{CHGENB} = V_{LOGIC}$	0.1			0.8	$\mu$ A	
$V_{IO}^{(2)}$	$8.8$ V < $V_{CC} < 35$ V, $CAO = CA-$	10				mV	
$A_{VO}$	$1$ V < $V_{AO} < 4$ V	60	90			dB	
GBW	$T_J = 25^\circ\text{C}$ , $f = 100$ KHz	1	1.5			MHz	
$V_{OL}$	$I_O = 250$ $\mu$ A	0.4			0.6	V	
$V_{OH}$	$I_O = -5$ mA	4.5	5			V	
	Output source current	$CAO = 4$ V			-25	-12	mA
	Output sink current	$CAO = 1$ V			2	3	mA
$I_{CA-}$ , $I_{TRCK\_CONTRO}$ $I_L$	$V_{CHGENB} = GND$	8.5	10	11.5		$\mu$ A	
<b>VOLTAGE AMPLIFIER (CEA)</b>							
$I_B$	Total bias current; regulating level	0.1			1	$\mu$ A	
$V_{IO}^{(2)}$	$8.8$ V < $V_{CC} < 35$ V, $V_{CM} = 2.3$ V, $V_{AO} = V_A-$	1.2				mV	
$A_{VO}$	$1$ V < $CAO < 4$ V	60	90			dB	
GBW	$T_J = 25^\circ\text{C}$ , $f = 100$ KHz	0.25	0.5			MHz	
$V_{OL}$	$I_O = 500$ $\mu$ A	0.4			0.6	V	
$V_{OH}$	$I_O = -500$ $\mu$ A	4.75	5	5.25		V	
	Output source current	$CAO = 4$ V			-2	-1	mA
	Output sink current	$CAO = 1$ V			2	2.5	mA
	VAO leakage: high impedance state	$V_{CHGENB} = GND$ , $STAT0 = 0$ and $STAT1 = 0$ , $V_{AO} = 2.3$ V			-1	1	$\mu$ A

(1) Not tested in production.

(2)  $V_{IO}$  is measured prior to packaging with internal probe pad.

**ELECTRICAL CHARACTERISTICS (continued)**

$T_A = -55^\circ\text{C}$  to  $125^\circ\text{C}$ ;  $C_T = 430$  pF,  $R_{SET} = 11.5$  K $\Omega$ ,  $R_{10} = 10$  K $\Omega$ ,  $R_{THM} = 10$  K $\Omega$ ,  $V_{CC} = 15$  V, Output no load,  $R_{STAT0} = R_{STAT1} = 10$  K $\Omega$ , CHGENB = OVCTAP = VLOGIC,  $T_A = T_J$  (unless otherwise noted)

PARAMETER	TEST CONDITIONS	MIN	TYP	MAX	UNIT
<b>PULSE WIDTH MODULATOR</b>					
Maximum duty cycle	CAO = 0.6 V	90	95	100	%
Modulator gain	CAO = 2.5 V, 3.2 V	63	71	80	%/V
OSC peak			3		V
OSC valley			1		V
<b>OSCILLATOR</b>					
Frequency	8.8 V < $V_{CC}$ < 35 V	151.65	168.50	185.35	KHz
<b>THERMISTOR DERIVED (<math>V_{ID} = V_{RTHM} - V_{R10}</math>)</b>					
Initial accuracy, $V_{AO}$ ( $R_{THM} = 10$ K $\Omega$ )	$V_{ID} = 0$ V, $R_{10} = R_{THM} = 10$ K $\Omega$ <sup>(3)</sup>	2.250	2.300	2.350	V
Line regulation	$V_{CC} = 8.8$ V to 35 V		3	10	mV
$V_{AO}$	$R_{THM} = 138$ K $\Omega$ , $R_{10} = 10$ K $\Omega$	2.435	2.495	2.545	V
	$R_{THM} = 33.63$ K $\Omega$ , $R_{10} = 10$ K $\Omega$	2.340	2.398	2.446	
	$R_{THM} = 1.014$ K $\Omega$ , $R_{10} = 10$ K $\Omega$	2.015	2.066	2.107	
<b>CHARGE ENABLE COMPARATOR (CEC)</b>					
Threshold voltage	As a function of $V_A$ .	0.99	1	1.01	V/V
Input bias current	CHGENB = 2.3 V	-0.5	-0.1		$\mu$ A
<b>VOLTAGE SENSE COMPARATOR (VSC)</b>					
Threshold voltage	STAT0 = 0, STAT1 = 0, Function of $V_{REF}$	0.944	0.95	0.955	V/V
	STAT0 = 1, STAT1 = 0, Function of $V_{REF}$	0.895	0.9	0.905	
<b>OVER CHARGE TAPER CURRENT COMPARATOR (OCTIC)</b>					
Threshold voltage	Function of 2.3 V REF, CA- = CAO	0.99	1	1.01	V/V
Input bias current	OVCTAP = 2.3 V	-0.5	-0.1		$\mu$ A
<b>LOGIC 5 V (VLOGIC)</b>					
VLOGIC	$V_{CC} = 15$ V	4.875	5	5.125	V
Line regulation	8.8 V < $V_{CC}$ < 35 V		3	15	mV
Load regulation	0 A < $I_O$ < 10 mA		3	15	mV
Reference comparator turn-on threshold			4.3	4.85	V
Short circuit current	$V_{REF} = 0$ V	30	50	80	mA
<b>OUTPUT STAGE</b>					
$I_{SINK}$ continuous			50		mA
$I_{PEAK}$			100		mA
$V_{OL}$	$I_O = 50$ mA		1	1.4	V
Leakage current	$V_{OUT} = 35$ V			25	$\mu$ A

(3) Thermistor initial accuracy is measured and trimmed with respect to  $V_{AO}$ ;  $V_{AO} = V_A$ .

**ELECTRICAL CHARACTERISTICS (continued)**

$T_A = -55^{\circ}\text{C}$  to  $125^{\circ}\text{C}$ ;  $C_T = 430\text{ pF}$ ,  $R_{SET} = 11.5\text{ K}\Omega$ ,  $R_{10} = 10\text{ K}\Omega$ ,  $R_{THM} = 10\text{ K}\Omega$ ,  $V_{CC} = 15\text{ V}$ , Output no load,  $R_{STAT0} = R_{STAT1} = 10\text{ K}\Omega$ ,  $CHGENB = OVCTAP = VLOGIC$ ,  $T_A = T_J$  (unless otherwise noted)

PARAMETER	TEST CONDITIONS	MIN	TYP	MAX	UNIT
<b>STAT0 AND STAT1 OPEN COLLECTOR OUTPUTS</b>					
Maximum sink current	$V_{OUT} = 8.8\text{ V}$	5	10		mA
Saturation voltage	$I_{OUT} = 5\text{ mA}$		0.1	0.45	V
Leakage current	$V_{OUT} = 35\text{ V}$			25	$\mu\text{A}$
<b>STATLV OPEN COLLECTOR OUTPUTS</b>					
Maximum sink current	$V_{OUT} = 5\text{ V}$	2	5		mA
Saturation voltage	$I_{OUT} = 2\text{ mA}$		0.1	0.45	V
Leakage current	$V_{OUT} = 5\text{ V}$			3	$\mu\text{A}$
<b>UVLO</b>					
Turn-on Threshold		6.8	7.8	8.8	V
Hysteresis		100	300	500	mV
<b><math>I_{CC}</math></b>					
$I_{CC}$ (run)	See <a href="#">Figure 1</a>		13	19	mA
$I_{CC}$ (off)	$V_{CC} = 6.5\text{ V}$		2		mA

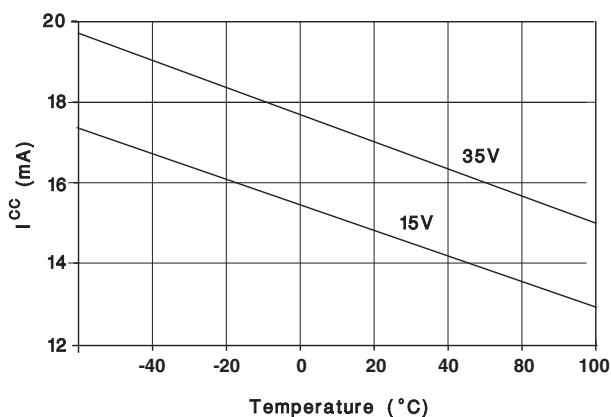

**Figure 1.  $I_{CC}$  vs Temperature**

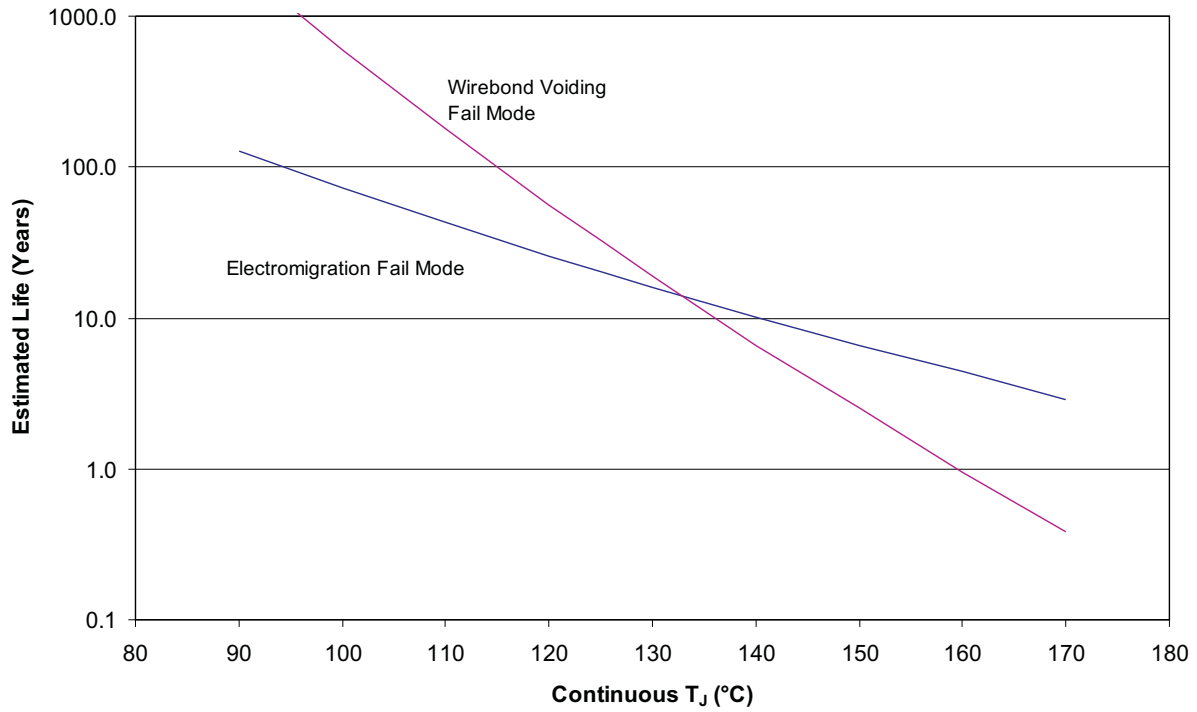

Notes:

1. See datasheet for absolute maximum and minimum recommended operating conditions.
2. Silicon operating life design goal is 10 years at 105°C junction temperature (does not include package interconnect life).
3. Enhanced plastic product disclaimer applies.

Figure 2. UC2909-EP Operating Life Derating Chart

**DEVICE INFORMATION**
**TERMINAL FUNCTIONS**

TERMINAL		DESCRIPTION
NAME	NO.	
CA-	13	The inverting input to the current error amplifier.
CAO	14	The output of the current error amplifier which is internally clamped to approximately 4 V. It is internally connected to the inverting input of the PWM comparator.
CS-, CS+	17, 16	The inverting and non-inverting inputs to the current sense amplifier. This amplifier has a fixed gain of five and a common-mode voltage range of from –250 mV to V <sub>CC</sub> .
CSO	15	The output of the current sense amplifier which is internally clamped to approximately 5.7 V.
CHGENB	10	The input to a comparator that detects when battery voltage is low and places the charger in a trickle charge state. The charge enable comparator makes the output of the voltage error amplifier a high impedance while forcing a fixed 10 mA into CA- to set the trickle charge current.
GND	3	The reference point for the internal reference, all thresholds, and the return for the remainder of the device. The output sink transistor is wired directly to this pin.
OVCTAP	9	The overcharge current taper pin detects when the output current has tapered to the float threshold in the overcharge state.
OSC	19	The oscillator ramp pin which has a capacitor (C <sub>T</sub> ) to ground. The ramp oscillates between approximately 1 V to 3 V and the frequency is approximated by: $frequency = \frac{1}{1.2 \cdot C_T \cdot R_{SET}} \quad (1)$
OUT	5	The output of the PWM driver which consists of an open collector output transistor with 100-mA sink capability.
R10	20	Input used to establish a differential voltage corresponding to the temperature of the thermistor. Connect a 10-KΩ resistor to ground from this point.
RSET	18	A resistor to ground programs the oscillator charge current and the trickle control current for the oscillator ramp. The oscillator charge current is approximately: $\frac{1.75}{R_{SET}} \quad (2)$ The trickle control current (I <sub>TRCK_CONTROL</sub> ) is approximately: $\frac{0.115}{R_{SET}} \quad (3)$
RTHM	1	A 10-KΩ thermistor is connected to ground and is thermally connected to the battery. The resistance will vary exponentially over temperature and its change is used to vary the internal 2.3-V reference by -3.9 mV/°C. The recommended thermistor for this function is part number L1005-5744-103-D1, Keystone Carbon Company, St. Marys, PA.
STAT0	7	This open collector pin is the first decode bit used to decode the charge states.
STAT1	6	This open collector pin is the second decode bit used to decode the charge states.
STATLV	8	This bit is high when the charger is in the float state.
VA-	12	The inverting input to the voltage error amplifier.
VAO	11	The output of the voltage error amplifier. The upper output clamp voltage of this amplifier is 5 V.
VCC	4	The input voltage to the chip. The chip is operational between 7.5 V and 40 V and should be bypassed with a 1-μF capacitor. A typical I <sub>CC</sub> vs. temperature is shown in <a href="#">Figure 1</a> .
VLOGIC	2	The precision reference voltage. It should be bypassed with a 0.1-μF capacitor.

**CHARGE STATE DECODE CHART**

STAT0 and STAT1 are open collector outputs. The output is approximately 0.2 V for a logic 0.

	<b>STAT1</b>	<b>STAT0</b>
Trickle charge	0	0
Bulk charge	0	1
Over charge	1	0
Float charge	1	1



## APPLICATION INFORMATION

A block diagram of the UC2909 is shown on the first page, while a typical application circuit is shown in [Figure 3](#). The circuit in [Figure 3](#) requires a DC input voltage between 12 V and 40 V.

The UC2909 uses a voltage control loop with average current limiting to precisely control the charge rate of a lead-acid battery. The small increase in complexity of average current limiting is offset by the relative simplicity of the control loop design.

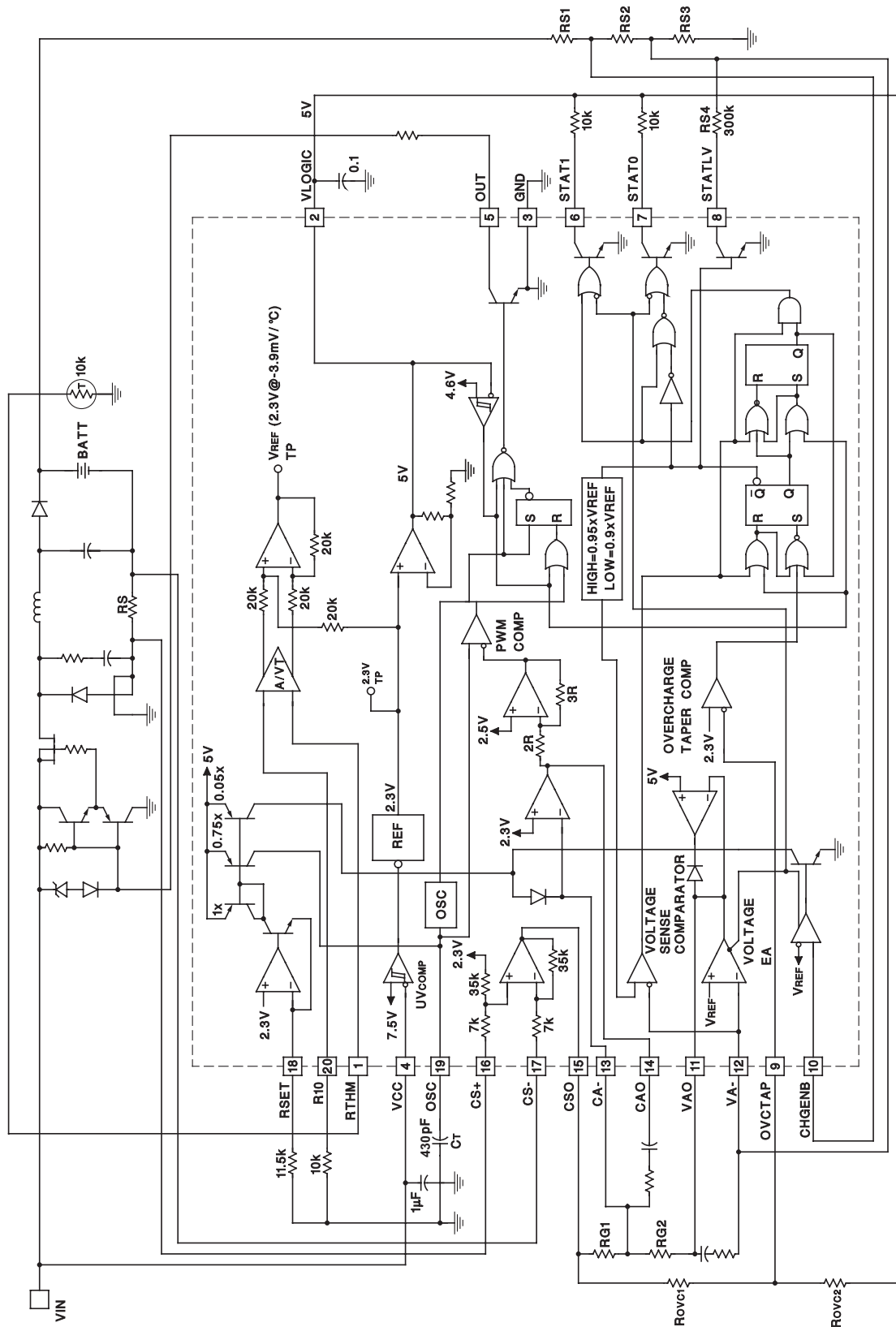

Figure 3. Typical Application Circuit

## Control Loop

### Current Sense Amplifier

This amplifier measures the voltage across the sense resistor  $R_S$  with a fixed gain of five and an offset voltage of 2.3 V. This voltage is proportional to the battery current. The most positive voltage end of  $R_S$  is connected to CSensuring the correct polarity going into the PWM comparator.

$CSO = 2.3 \text{ V}$  when there is zero battery current.

$R_S$  is chosen by dividing 350 mV by the maximum allowable load current. A smaller value for  $R_S$  can be chosen to reduce power dissipation.

Maximum charge current,  $I_{bulk}$ , is set by knowing the maximum voltage error amplifier output,  $V_{OH} = 5 \text{ V}$ , the maximum allowable drop across  $R_S$ , and setting the resistors  $RG1$  and  $RG2$  such that:

$$\frac{RG1}{RG2} = \frac{5 \cdot V_{RS}}{V_{LOGIC} - CA} = \frac{5 \cdot V_{RS}}{5 \text{ V} - 2.3 \text{ V}} = \frac{5 \cdot V_{RS}}{2.7 \text{ V}} = 1.852 \cdot I_{BULK} \cdot R_S \quad (4)$$

The maximum allowable drop across  $R_S$  is specified to limit the maximum swing at  $CSO$  to approximately 2 V to keep the  $CSO$  amplifier output from saturating.

No charge/load current:  $V_{CSO} = 2.3 \text{ V}$

Max charge/load current:  $V_{max(CSO)} = 2.3 \text{ V} - 2 \text{ V} = 0.3 \text{ V}$

### Voltage Error Amplifier

The voltage error amplifier (VEA) senses the battery voltage and compares it to the 2.3-V - 3.9-mV/°C thermistor generated reference. Its output becomes the current command signal and is summed with the current sense amplifier output. A 5-V voltage error amplifier upper clamp limits maximum load current. During the trickle charge state, the voltage amplifier output is opened (high impedance output) by the charge enable comparator. A trickle bias current is summed into the  $CA-$  input which sets the maximum trickle charge current.

The VEA,  $V_{OH} = 5 \text{ V}$  clamp saturates the voltage loop and consequently limits the charge current as stated in [Equation 4](#).

During the trickle bias state the maximum allowable charge current (ITC) is similarly determined:

$$ITC = \frac{I_{TRCK\_CONTROL} \cdot RG1}{R_S \cdot 5} \quad (5)$$

$I_{TRCK\_CONTROL}$  is the fixed control current into  $CA-$ .  $I_{TRCK\_CONTROL}$  is 10  $\mu\text{A}$  when  $R_{SET} = 11.5 \text{ K}\Omega$ . See  $R_{SET}$  pin description for equation.

### Current Error Amplifier

The current error amplifier (CA) compares the output of the current sense amplifier to the output of the voltage error amplifier. The output of the CA forces a PWM duty cycle which results in the correct average battery current. With integral compensation, the CA will have a very high DC current gain, resulting in effectively no average DC current error. For stability purposes, the high frequency gain of the CA must be designed such that the magnitude of the down slope of the CA output signal is less than or equal to the magnitude of the up slope of the PWM ramp.

## Charge Algorithm

### Trickle Charge State

**STAT0 = STAT1 = STATLV = logic 0**

When  $CHGNB$  is less than  $V_{REF}$  (2.3 V - 3.9 mV/°C),  $STATLV$  is forced low. This decreases the sense voltage divider ratio, forcing the battery to overcharge ( $V_{OC}$ ).

$$V_{OC} = (V_{REF}) \cdot \frac{(RS1 + RS2 + RS3 \parallel RS4)}{(RS3 \parallel RS4)} \quad (6)$$

During the trickle charge state, the output of the voltage error amplifier is high impedance. The trickle control current is directed into the CA- pin setting the maximum trickle charge current. The trickle charge current is defined in [Equation 5](#).

#### Bulk Charge State

**STAT1 = STATLV = logic 0, STAT0 = logic 1**

As the battery charges, the UC2909 will transition from trickle to bulk charge when CHGENB becomes greater than 2.3 V. The transition equation is:

$$V_T = (V_{REF}) \cdot \frac{(RS1 + RS2 + RS3 \parallel RS4)}{(RS2 + RS3 \parallel RS4)} \quad (7)$$

STATLV is still driven low.

During the bulk charge state, the voltage error amplifier is now operational and is commanding maximum charge current ( $I_{BULK}$ ) set by [Equation 4](#). The voltage loop attempts to force the battery to VOC.

#### Overcharge State

**STAT0 = STATLV = logic 0, STAT1 = logic 1**

The battery voltage surpasses 95% of VOC indicating the UC2909 is in its overcharge state.

During the overcharge charge state, the voltage loop becomes stable and the charge current begins to taper off. As the charge current tapers off, the voltage at CSO increases toward its null point of 2.3 V. The center connection of the two resistors between CSO and VLOGIC sets the overcurrent taper threshold (OVCTAP). Knowing the desired overcharge terminate current ( $I_{OCT}$ ), the resistors  $R_{OVC1}$  and  $R_{OVC2}$  can be calculated by choosing a value of  $R_{OVC2}$  and using the following equation:

$$R_{OVC1} = (1.8518) \cdot I_{OCT} \cdot RS \cdot R_{OVC2} \quad (8)$$

#### Float State

**STAT0 = STAT1 = STATLV = logic 1**

The battery charge current tapers below its OVCTAP threshold, and forces STATLV high increasing the voltage sense divider ratio. The voltage loop now forces the battery charger to regulate at its float state voltage ( $V_F$ ).

$$V_F = (V_{REF}) \cdot \frac{(RS1 + RS2 + RS3)}{RS3} \quad (9)$$

If the load drains the battery to less than 90% of  $V_F$ , the charger goes back to the bulk charge state, STATE 1.

#### Off Line Applications

For off line charge applications, either [Figure 4](#) or [Figure 5](#) can be used as a baseline. [Figure 4](#) has the advantage of high frequency operation resulting in a small isolation transformer. [Figure 5](#) is a simpler design, but at the expense of larger magnetics.

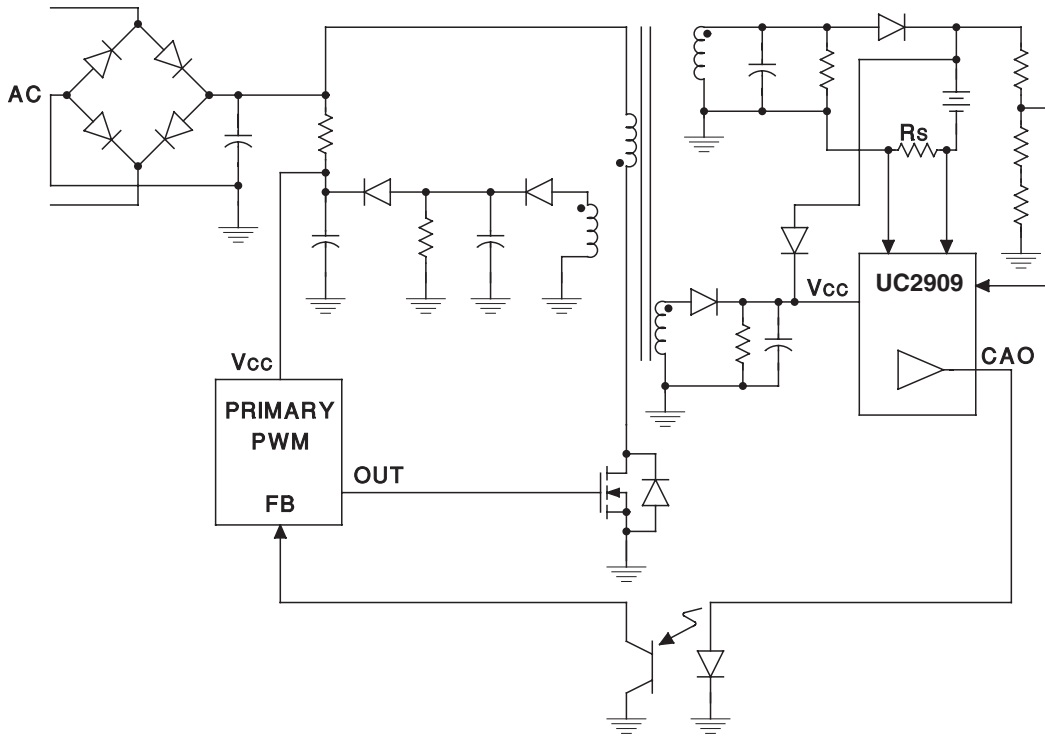

Figure 4. Off Line Charger With Primary Side PWM

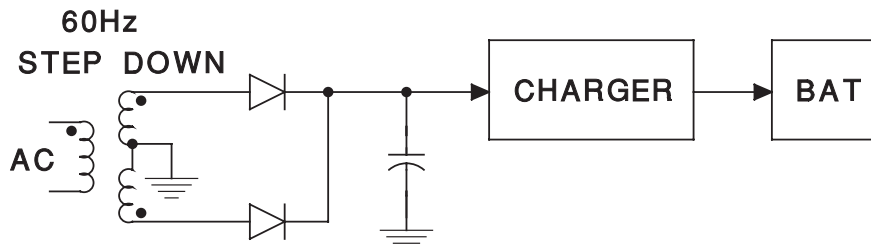

Figure 5. Isolated Off Line Charger

**PACKAGING INFORMATION**

Orderable Device	Status (1)	Package Type	Package Drawing	Pins	Package Qty	Eco Plan (2)	Lead/Ball Finish (6)	MSL Peak Temp (3)	Op Temp (°C)	Device Marking (4/5)	Samples
UC2909MDWREP	ACTIVE	SOIC	DW	20	2000	Green (RoHS & no Sb/Br)	CU NIPDAU	Level-2-260C-1 YEAR	-55 to 125	UC2909EP	<a href="#">Samples</a>
V62/10616-01XE	ACTIVE	SOIC	DW	20	2000	Green (RoHS & no Sb/Br)	CU NIPDAU	Level-2-260C-1 YEAR	-55 to 125	UC2909EP	<a href="#">Samples</a>

(1) The marketing status values are defined as follows:

**ACTIVE:** Product device recommended for new designs.

**LIFEBUY:** TI has announced that the device will be discontinued, and a lifetime-buy period is in effect.

**NRND:** Not recommended for new designs. Device is in production to support existing customers, but TI does not recommend using this part in a new design.

**PREVIEW:** Device has been announced but is not in production. Samples may or may not be available.

**OBSELETE:** TI has discontinued the production of the device.

(2) Eco Plan - The planned eco-friendly classification: Pb-Free (RoHS), Pb-Free (RoHS Exempt), or Green (RoHS & no Sb/Br) - please check <http://www.ti.com/productcontent> for the latest availability information and additional product content details.

**TBD:** The Pb-Free/Green conversion plan has not been defined.

**Pb-Free (RoHS):** TI's terms "Lead-Free" or "Pb-Free" mean semiconductor products that are compatible with the current RoHS requirements for all 6 substances, including the requirement that lead not exceed 0.1% by weight in homogeneous materials. Where designed to be soldered at high temperatures, TI Pb-Free products are suitable for use in specified lead-free processes.

**Pb-Free (RoHS Exempt):** This component has a RoHS exemption for either 1) lead-based flip-chip solder bumps used between the die and package, or 2) lead-based die adhesive used between the die and leadframe. The component is otherwise considered Pb-Free (RoHS compatible) as defined above.

**Green (RoHS & no Sb/Br):** TI defines "Green" to mean Pb-Free (RoHS compatible), and free of Bromine (Br) and Antimony (Sb) based flame retardants (Br or Sb do not exceed 0.1% by weight in homogeneous material)

(3) MSL, Peak Temp. - The Moisture Sensitivity Level rating according to the JEDEC industry standard classifications, and peak solder temperature.

(4) There may be additional marking, which relates to the logo, the lot trace code information, or the environmental category on the device.

(5) Multiple Device Markings will be inside parentheses. Only one Device Marking contained in parentheses and separated by a "~" will appear on a device. If a line is indented then it is a continuation of the previous line and the two combined represent the entire Device Marking for that device.

(6) Lead/Ball Finish - Orderable Devices may have multiple material finish options. Finish options are separated by a vertical ruled line. Lead/Ball Finish values may wrap to two lines if the finish value exceeds the maximum column width.

**Important Information and Disclaimer:** The information provided on this page represents TI's knowledge and belief as of the date that it is provided. TI bases its knowledge and belief on information provided by third parties, and makes no representation or warranty as to the accuracy of such information. Efforts are underway to better integrate information from third parties. TI has taken and continues to take reasonable steps to provide representative and accurate information but may not have conducted destructive testing or chemical analysis on incoming materials and chemicals. TI and TI suppliers consider certain information to be proprietary, and thus CAS numbers and other limited information may not be available for release.

In no event shall TI's liability arising out of such information exceed the total purchase price of the TI part(s) at issue in this document sold by TI to Customer on an annual basis.

**OTHER QUALIFIED VERSIONS OF UC2909-EP :**

- Catalog: [UC2909](#)

**NOTE: Qualified Version Definitions:**

- Catalog - TI's standard catalog product

**TAPE AND REEL INFORMATION**

**QUADRANT ASSIGNMENTS FOR PIN 1 ORIENTATION IN TAPE**

\*All dimensions are nominal

Device	Package Type	Package Drawing	Pins	SPQ	Reel Diameter (mm)	Reel Width W1 (mm)	A0 (mm)	B0 (mm)	K0 (mm)	P1 (mm)	W (mm)	Pin1 Quadrant
UC2909MDWREP	SOIC	DW	20	2000	330.0	24.4	10.8	13.0	2.7	12.0	24.0	Q1



**TAPE AND REEL BOX DIMENSIONS**



\*All dimensions are nominal

Device	Package Type	Package Drawing	Pins	SPQ	Length (mm)	Width (mm)	Height (mm)
UC2909MDWREP	SOIC	DW	20	2000	367.0	367.0	45.0

# DW0020A



# PACKAGE OUTLINE

## SOIC - 2.65 mm max height

SOIC



### NOTES:

1. All linear dimensions are in millimeters. Dimensions in parenthesis are for reference only. Dimensioning and tolerancing per ASME Y14.5M.
2. This drawing is subject to change without notice.
3. This dimension does not include mold flash, protrusions, or gate burrs. Mold flash, protrusions, or gate burrs shall not exceed 0.15 mm per side.
4. This dimension does not include interlead flash. Interlead flash shall not exceed 0.43 mm per side.
5. Reference JEDEC registration MS-013.

# EXAMPLE BOARD LAYOUT

DW0020A

SOIC - 2.65 mm max height

SOIC



LAND PATTERN EXAMPLE  
SCALE:6X



SOLDER MASK DETAILS

4220724/A 05/2016

NOTES: (continued)

- 6. Publication IPC-7351 may have alternate designs.
- 7. Solder mask tolerances between and around signal pads can vary based on board fabrication site.

# EXAMPLE STENCIL DESIGN

DW0020A

SOIC - 2.65 mm max height

SOIC



SOLDER PASTE EXAMPLE  
BASED ON 0.125 mm THICK STENCIL  
SCALE:6X

4220724/A 05/2016

NOTES: (continued)

8. Laser cutting apertures with trapezoidal walls and rounded corners may offer better paste release. IPC-7525 may have alternate design recommendations.
9. Board assembly site may have different recommendations for stencil design.

## IMPORTANT NOTICE

Texas Instruments Incorporated and its subsidiaries (TI) reserve the right to make corrections, enhancements, improvements and other changes to its semiconductor products and services per JESD46, latest issue, and to discontinue any product or service per JESD48, latest issue. Buyers should obtain the latest relevant information before placing orders and should verify that such information is current and complete. All semiconductor products (also referred to herein as "components") are sold subject to TI's terms and conditions of sale supplied at the time of order acknowledgment.

TI warrants performance of its components to the specifications applicable at the time of sale, in accordance with the warranty in TI's terms and conditions of sale of semiconductor products. Testing and other quality control techniques are used to the extent TI deems necessary to support this warranty. Except where mandated by applicable law, testing of all parameters of each component is not necessarily performed.

TI assumes no liability for applications assistance or the design of Buyers' products. Buyers are responsible for their products and applications using TI components. To minimize the risks associated with Buyers' products and applications, Buyers should provide adequate design and operating safeguards.

TI does not warrant or represent that any license, either express or implied, is granted under any patent right, copyright, mask work right, or other intellectual property right relating to any combination, machine, or process in which TI components or services are used. Information published by TI regarding third-party products or services does not constitute a license to use such products or services or a warranty or endorsement thereof. Use of such information may require a license from a third party under the patents or other intellectual property of the third party, or a license from TI under the patents or other intellectual property of TI.

Reproduction of significant portions of TI information in TI data books or data sheets is permissible only if reproduction is without alteration and is accompanied by all associated warranties, conditions, limitations, and notices. TI is not responsible or liable for such altered documentation. Information of third parties may be subject to additional restrictions.

Resale of TI components or services with statements different from or beyond the parameters stated by TI for that component or service voids all express and any implied warranties for the associated TI component or service and is an unfair and deceptive business practice. TI is not responsible or liable for any such statements.

Buyer acknowledges and agrees that it is solely responsible for compliance with all legal, regulatory and safety-related requirements concerning its products, and any use of TI components in its applications, notwithstanding any applications-related information or support that may be provided by TI. Buyer represents and agrees that it has all the necessary expertise to create and implement safeguards which anticipate dangerous consequences of failures, monitor failures and their consequences, lessen the likelihood of failures that might cause harm and take appropriate remedial actions. Buyer will fully indemnify TI and its representatives against any damages arising out of the use of any TI components in safety-critical applications.

In some cases, TI components may be promoted specifically to facilitate safety-related applications. With such components, TI's goal is to help enable customers to design and create their own end-product solutions that meet applicable functional safety standards and requirements. Nonetheless, such components are subject to these terms.

No TI components are authorized for use in FDA Class III (or similar life-critical medical equipment) unless authorized officers of the parties have executed a special agreement specifically governing such use.

Only those TI components which TI has specifically designated as military grade or "enhanced plastic" are designed and intended for use in military/aerospace applications or environments. Buyer acknowledges and agrees that any military or aerospace use of TI components which have **not** been so designated is solely at the Buyer's risk, and that Buyer is solely responsible for compliance with all legal and regulatory requirements in connection with such use.

TI has specifically designated certain components as meeting ISO/TS16949 requirements, mainly for automotive use. In any case of use of non-designated products, TI will not be responsible for any failure to meet ISO/TS16949.

### Products

Audio	<a href="http://www.ti.com/audio">www.ti.com/audio</a>
Amplifiers	<a href="http://amplifier.ti.com">amplifier.ti.com</a>
Data Converters	<a href="http://dataconverter.ti.com">dataconverter.ti.com</a>
DLP® Products	<a href="http://www.dlp.com">www.dlp.com</a>
DSP	<a href="http://dsp.ti.com">dsp.ti.com</a>
Clocks and Timers	<a href="http://www.ti.com/clocks">www.ti.com/clocks</a>
Interface	<a href="http://interface.ti.com">interface.ti.com</a>
Logic	<a href="http://logic.ti.com">logic.ti.com</a>
Power Mgmt	<a href="http://power.ti.com">power.ti.com</a>
Microcontrollers	<a href="http://microcontroller.ti.com">microcontroller.ti.com</a>
RFID	<a href="http://www.ti-rfid.com">www.ti-rfid.com</a>
OMAP Applications Processors	<a href="http://www.ti.com/omap">www.ti.com/omap</a>
Wireless Connectivity	<a href="http://www.ti.com/wirelessconnectivity">www.ti.com/wirelessconnectivity</a>

### Applications

Automotive and Transportation	<a href="http://www.ti.com/automotive">www.ti.com/automotive</a>
Communications and Telecom	<a href="http://www.ti.com/communications">www.ti.com/communications</a>
Computers and Peripherals	<a href="http://www.ti.com/computers">www.ti.com/computers</a>
Consumer Electronics	<a href="http://www.ti.com/consumer-apps">www.ti.com/consumer-apps</a>
Energy and Lighting	<a href="http://www.ti.com/energy">www.ti.com/energy</a>
Industrial	<a href="http://www.ti.com/industrial">www.ti.com/industrial</a>
Medical	<a href="http://www.ti.com/medical">www.ti.com/medical</a>
Security	<a href="http://www.ti.com/security">www.ti.com/security</a>
Space, Avionics and Defense	<a href="http://www.ti.com/space-avionics-defense">www.ti.com/space-avionics-defense</a>
Video and Imaging	<a href="http://www.ti.com/video">www.ti.com/video</a>

### TI E2E Community

[e2e.ti.com](http://e2e.ti.com)