

UBA2036TS

Full bridge control IC for HID automotive lighting

Rev. 01 — 30 October 2008

Product data sheet

1. General description

The UBA2036 is a high voltage monolithic Integrated Circuit (IC) manufactured in a High Voltage Silicon On Insulator (HVSOI) process. This circuit is designed for driving MOSFETs in a full bridge configuration. In addition, it features a disable function, an internal adjustable oscillator and an external clock input function with a high-voltage level shifter for driving the bridge. To guarantee an accurate 50 % duty cycle, the oscillator signal can be passed through a divider before being fed to the output drivers.

The UBA2036 is especially suitable for High Intensity Discharge (HID) lamp drivers for car headlights, projectors and general lighting applications.

2. Features

- Full bridge driver circuit
- Integrated bootstrap diodes
- 464 V integrated high voltage level shift function to drive HID lamps below ground level
- 550 V series regulator input to make the internal supply
- 550 V maximum bridge voltage
- Accurate bridge disable function
- Input for start-up delay
- Adjustable oscillator frequency
- Selectable frequency divider
- Predefined bridge position during start-up
- Adaptive non-overlap

3. Applications

- The UBA2036 can drive (via the power MOSFETs) any kind of load in a full bridge configuration
- The circuit is especially designed as a commutator controller for HID lamps in car headlights, projectors and general lighting applications

4. Ordering information

Table 1. Ordering information

Type number	Package		
	Name	Description	Version
UBA2036TS	SSOP28	plastic shrink small outline package; 28 leads; body width 5.3 mm	SOT341-1

5. Block diagram

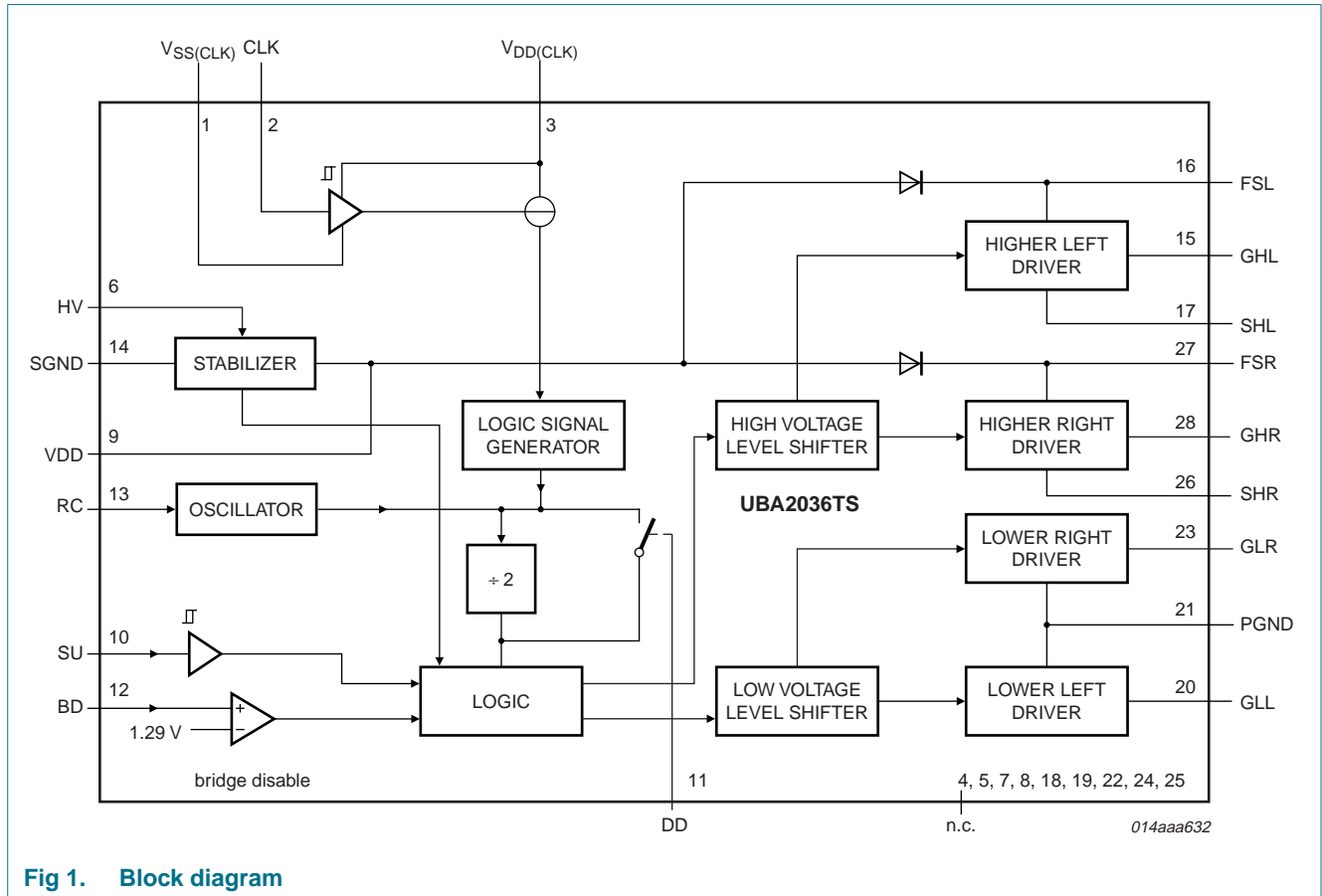

Fig 1. Block diagram

6. Pinning information

6.1 Pinning

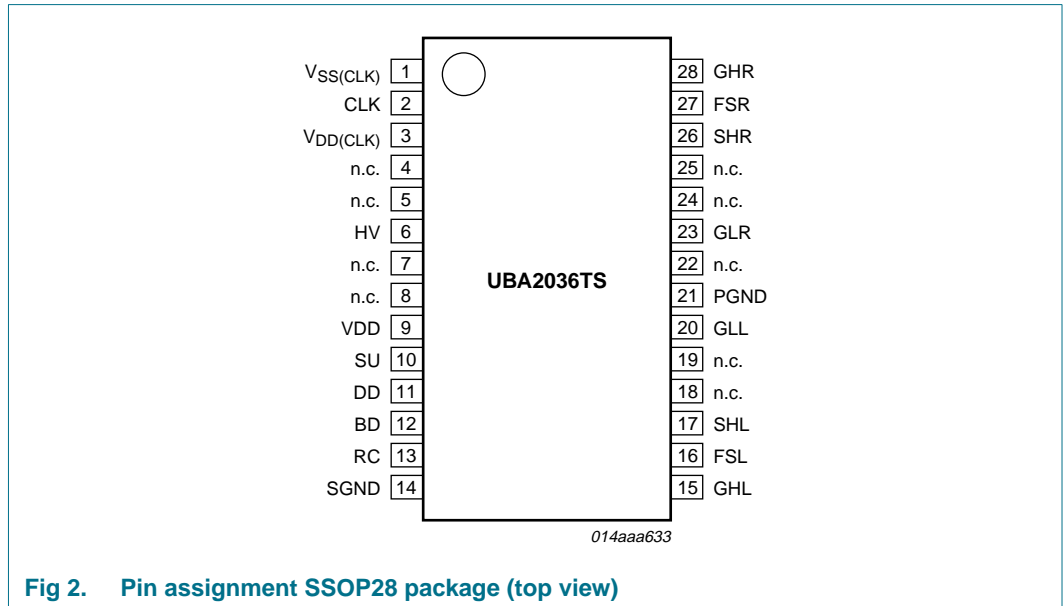

Fig 2. Pin assignment SSOP28 package (top view)

6.2 Pin description

Table 2. Pin description

Symbol	Pin	Description
V _{SS(CLK)}	1	negative supply voltage for logic oscillator input
CLK	2	oscillator input
V _{DD(CLK)}	3	positive supply voltage for logic oscillator input
n.c.	4	not connected
n.c.	5	not connected
HV	6	high voltage supply input for internal series regulator
n.c.	7	not connected
n.c.	8	not connected
VDD	9	internal low voltage supply
SU	10	input for start-up delay
DD	11	input for divider disable
BD	12	input for bridge disable
RC	13	RC input for internal oscillator
SGND	14	signal ground
GHF	15	gate driver output for upper left MOSFET
FSL	16	floating supply left
SHL	17	source upper left MOSFET
n.c.	18	not connected
n.c.	19	not connected

Table 2. Pin description ...continued

Symbol	Pin	Description
GLL	20	gate driver output for lower left MOSFET
PGND	21	power ground
n.c.	22	not connected
GLR	23	gate driver output for lower right MOSFET
n.c.	24	not connected
n.c.	25	not connected
SHR	26	source upper right MOSFET
FSR	27	floating supply right
GHR	28	gate driver upper right MOSFET

7. Functional description

7.1 Supply voltage

The UBA2036 is powered by a supply voltage applied to pin HV, e.g. the supply voltage of the full bridge. The IC generates its own low supply voltage for its internal circuitry. Therefore an additional low voltage supply is not required. A capacitor has to be connected to pin VDD to obtain a ripple-free internal supply voltage. The circuit can also be powered by a low voltage supply directly applied to pin VDD. In this case pin HV should be connected to pin VDD or pin SGND. The maximum current that the internal series regulator can deliver, is temperature dependent. This is shown in [Figure 3](#).

7.2 Start-up

With an increasing supply voltage the IC enters the start-up state i.e. the upper power transistors are set in off-state and the lower power transistors are switched on. During the start-up state the bootstrap capacitors are charged. The start-up state is defined until $V_{VDD} = V_{startup(VDD)}$ or $V_{HV} = V_{startup(HV)}$. The state of the outputs during the start-up phase is overruled by the bridge disable function.

7.3 Oscillation state

At the moment the supply voltage on pin VDD exceeds $V_{startup(VDD)}$ or the supply voltage on pin V_{HV} exceeds $V_{startup(HV)}$, the output voltage of the full bridge depends on the control signals on pins CLK, SU, DD and BD. This is listed in [Table 3](#).

As soon as the supply voltage on pin VDD becomes lower than $V_{UVLO(VDD)}$ or the supply voltage on pin V_{HV} becomes lower than $V_{UVLO(HV)}$, the IC enters the start-up state again.

Table 3. Driver

Gate driver output voltages as function of the logical levels at the pins BD, SU, DD and CLK.

Device state	BD	SU	DD	CLK	GHL	GHR	GLL	GLR
Start-up state	1	-	-	-	0 (= V_{SHL})	0 (= V_{SHR})	0 (= V_{PGND})	0 (= V_{PGND})
	0	-	-	-	0 (= V_{SHL})	0 (= V_{SHR})	1 (= V_{VDD})	1 (= V_{VDD})

Table 3. Driver ...continued

Gate driver output voltages as function of the logical levels at the pins BD, SU, DD and CLK.

Device state	BD	SU	DD	CLK	GHL	GHR	GLL	GLR
Oscillation state	1	-	-	-	0 (= V _{SHL})	0 (= V _{SHR})	0 (= V _{PGND})	0 (= V _{PGND})
	0	0	-	-	0 (= V _{SHL})	0 (= V _{SHR})	1 (= V _{VDD})	1 (= V _{VDD})
	0	1	1	1	0 (= V _{SHL})	1 (= V _{FSR})	1 (= V _{VDD})	0 (= V _{PGND})
	0	1	1	0	1 (= V _{FSL})	0 (= V _{SHR})	0 (= V _{PGND})	1 (= V _{VDD})
	0	1	0 ^[1]	1 → 0 ^[2]	$\overline{\text{GHL}}$	$\overline{\text{GHR}}$	$\overline{\text{GLL}}$	$\overline{\text{GLR}}$

[1] If pin DD = 0 the bridge enters the state (oscillation state and pin BD = 0 and pin SU = 1) in the pre-defined position: V_{GHL} = V_{FSL}, V_{GLR} = V_{VDD}, V_{GLL} = V_{PGND}, and V_{GHR} = V_{SHR}.

[2] Only if the level of pin CLK changes from logical 1 to 0, the level of outputs GHL, GHR, GLL and GLR changes.

If there is no external clock available, the internal oscillator can be used. The design equation for the bridge oscillator frequency is shown in [Equation 1](#).

$$f_{bridge} = \frac{1}{K_{osc} \times R_{osc} \times C_{osc}} \tag{1}$$

R_{osc} and C_{osc} are external components connected to the RC pin (R_{osc} connected to pin VDD and C_{osc} connected to pin SGND). In this situation the pins V_{DD(CLK)}, CLK and V_{SS(CLK)} can be connected to SGND.

The clock signal, coming from either pin RC or pin CLK, is divided by two in order to obtain a 50 % duty-cycle gate drive signal. This can be achieved by applying a voltage to the DD input lower than V_{IL(DD)} (e.g. connect pin DD to pin SGND).

7.4 Non-overlap time

In the full bridge configuration the non-overlap time is defined as the time between turning off the two conducting MOSFETs and turning on the two other MOSFETs. The non-overlap time is realized by means of an adaptive non-overlap circuit. With an adaptive non-overlap, the application determines the duration of the non-overlap and makes the non-overlap time optimal for each frequency. The non-overlap time is determined by the duration of the falling slope of the relevant half bridge voltage. The occurrence of a slope is sensed internally. The minimum non-overlap time is internally fixed.

7.5 Start-up delay

A simple resistor-capacitor (RC) filter (R between pin VDD and pin SU; C between pin SU and pin SGND) or a control signal from a processor can be used to make a start-up delay. This can be beneficial for those applications in which building up the high voltage takes a larger amount of time: A start-up delay will ensure that the HID system will not start up before this high voltage has been reached.

7.6 Bridge disable

The bridge disable function can be used to switch off all the MOSFETs as soon as the voltage on pin BD exceeds the bridge disable voltage V_{BD}. The bridge disable function overrules all the other states.

8. Limiting values

Table 4. Limiting values

In accordance with the Absolute Maximum Rating System (IEC 60134). All voltages are measured with respect to signal ground (pin 14); positive currents flow into the chip. The voltage ratings are valid provided other ratings are not violated.

Symbol	Parameter	Conditions	Min	Max	Unit
General					
T_{amb}	ambient temperature		-40	+125	°C
T_j	junction temperature		-40	+150	°C
T_{stg}	storage temperature		-55	+150	°C
Voltages					
V_{VDD}	voltage on pin VDD	DC	0	14	V
		maximum pulse time = 100 ns	0	17	V
V_{HV}	voltage on pin HV		0	550	V
V_{SHL}	voltage on pin SHL	with respect to PGND and SGND	-3	550	V
		with respect to SGND; maximum pulse time = 1 μ s	-14	550	V
V_{SHR}	voltage on pin SHR	with respect to PGND and SGND	-3	550	V
		with respect to SGND; maximum pulse time = 1 μ s	-14	550	V
V_{FSL}	voltage on pin FSL	with respect to SHL	0	14	V
V_{FSR}	voltage on pin FSR	with respect to SHR	0	14	V
V_{GHL}	voltage on pin GHL		V_{SHL}	V_{FSL}	V
V_{GHR}	voltage on pin GHR		V_{SHR}	V_{FSR}	V
V_{GLL}	voltage on pin GLL		V_{PGND}	V_{VDD}	V
V_{GLR}	voltage on pin GLR		V_{PGND}	V_{VDD}	V
V_{PGND}	voltage on pin PGND		0	5	V
$V_{SS(CLK)}$	CLK ground supply voltage	$t < 1$ s	0	464	V
$V_{DD(CLK)}$	CLK supply voltage	$t < 1$ s	0	464	V
		with respect to $V_{SS(CLK)}$:			
		DC	0	14	V
		maximum pulse time = 100 ns	0	17	V
V_i	input voltage	pins CLK, SU, BD, and DD; with respect to $V_{SS(CLK)}$:			
		DC	0	V_{VDD}	V
		maximum pulse time = 100 ns	0	17	V
		pin RC:			
		maximum pulse time = 100 ns	0	17	V
SR	slew rate	pins SHL and SHR	-	6	V/ns
		pin $V_{SS(CLK)}$	-	0.5	V/ μ s
Currents					
R_{osc}	oscillator resistance	connected between pins VDD and RC	100	-	k Ω

Table 4. Limiting values ...continued

In accordance with the Absolute Maximum Rating System (IEC 60134). All voltages are measured with respect to signal ground (pin 14); positive currents flow into the chip. The voltage ratings are valid provided other ratings are not violated.

Symbol	Parameter	Conditions	Min	Max	Unit
ESD					
V _{ESD}	electrostatic discharge voltage	human body model			
		HV, V _{SS(CLK)} , V _{DD(CLK)} , CLK, FSL, FSR, GHL, GHR, SHL, SHR	-	900	V
		other pins	-	2	kV
		machine model; all pins	-	200	V
		charged device model; all pins	-	500	V

9. Thermal characteristics

Table 5. Thermal characteristics

Symbol	Parameter	Conditions	Typ	Unit
R _{th(j-a)}	thermal resistance from junction to ambient	in free air	100	K/W

10. Characteristics

Table 6. Characteristics

T_j = -40 °C to 125 °C; all voltages are measured with respect to signal ground (pin 14); currents are positive when flowing into the IC, Unless otherwise specified.

Symbol	Parameter	Conditions	Min	Typ	Max	Unit
High voltage						
I _{leak}	leakage current	pin HV; I _{HV} (V _{HV} = 565 V) – I _{HV} (V _{HV} = 500 V)	-	0	10	μA
		pin FSL; V _{FSL} = V _{SHL} = V _{GHL} = 564 V	-	0	5	μA
		pin FSR; V _{FSR} = V _{SHR} = V _{GHR} = 564 V	-	0	5	μA
		pin V _{SS(CLK)} ; V _{SS(CLK)} = V _{clk} = 450 V	-	0	10	μA
		pin V _{DD(CLK)} ; V _{DD(CLK)} = V _{clk} = 464 V	-	0	10	μA
Start-up via HV pin						
I _{I(HV)}	input current on pin HV	V _{HV} = 80 V	-	590	825	μA
V _{startup(HV)}	start-up voltage on pin HV		11.3	13.2	14.7	V
V _{UVLO(HV)}	undervoltage lockout voltage on pin HV		8.6	10.7	12.2	V
V _{hys}	hysteresis voltage		2	2.5	3	V
V _{VDD}	voltage on pin VDD	V _{HV} = 20 V	10.5	12	13.5	V
Start-up via VDD pin						
I _{I(VDD)}	input current on pin VDD	V _{VDD} = 8.25 V	-	500	800	μA
V _{startup(VDD)}	start-up voltage on pin VDD		8.25	9.0	9.75	V

Table 6. Characteristics ...continued

$T_j = -40\text{ }^\circ\text{C}$ to $125\text{ }^\circ\text{C}$; all voltages are measured with respect to signal ground (pin 14); currents are positive when flowing into the IC, Unless otherwise specified.

Symbol	Parameter	Conditions	Min	Typ	Max	Unit
$V_{UVLO(VDD)}$	undervoltage lockout voltage on pin VDD		5.75	6.5	7.25	V
V_{hys}	hysteresis voltage		2	2.5	3	V
Gate drivers						
R_{on}	on-state resistance	GHR and GHL drivers; $V_{FSL} = V_{FSR} = 12\text{ V}$; $V_{SHL} = V_{SHR} = 0\text{ V}$; $I_{GHL} = I_{GHR} = -50\text{ mA}$	-	20	42	Ω
		GLL and GLR drivers; $V_{VDD} = 12\text{ V}$; $V_{PGND} = 0\text{ V}$; $I_{GLL} = I_{GLR} = -50\text{ mA}$	-	20	42	Ω
R_{off}	off-state resistance	GHR and GHL drivers; $V_{FSL} = V_{FSR} = 12\text{ V}$; $V_{SHL} = V_{SHR} = 0\text{ V}$; $I_{GHL} = I_{GHR} = 50\text{ mA}$	-	12	26	Ω
		GLR and GLL drivers; $V_{VDD} = 12\text{ V}$; $V_{PGND} = 0\text{ V}$; $I_{GLL} = I_{GLR} = 50\text{ mA}$	-	12	26	Ω
$I_{O(source)}$	output source current	$V_{FSL} = V_{FSR} = V_{VDD} = 12\text{ V}$; $V_{SHL} = V_{SHR} = 0\text{ V}$; $V_{GHL} = V_{GHR} = V_{GLL} = V_{GLR} = 8\text{ V}$	-	200	-	mA
$I_{O(sink)}$	output sink current	$V_{FSL} = V_{FSR} = V_{VDD} = 12\text{ V}$; $V_{SHL} = V_{SHR} = 0\text{ V}$; $V_{GHL} = V_{GHR} = V_{GLL} = V_{GLR} = 8\text{ V}$	-	200	-	mA
$V_{d(bs)}$	bootstrap diode voltage	current on diode = 1 mA	0.8	1.0	1.2	V
dV/dt	rate of change of voltage	absolute values	5	15	25	V/ μs
t_{no}	non-overlap time		600	900	1300	ns
V_{UVLO}	undervoltage lockout voltage	high side driver	-	4.0	5.5	V
I_{FS}	current on pin FS	$V_{FSL} = V_{FSR} = 12\text{ V}$; $V_{SHL} = V_{SHR} = 0\text{ V}$	1	4	7	μA
I_{FSL}/I_{FSR}	current on pin FSL to current on pin FSR ratio		0.8	-	1.2	
DD input						
$V_{IH(DD)}$	HIGH-level input voltage on pin DD	$V_{VDD} = 12\text{ V}$	6	4.5	-	V
$V_{IL(DD)}$	LOW-level input voltage on pin DD	$V_{VDD} = 12\text{ V}$	-	-	3	V
I_I	input current	$V_{VDD} = 12\text{ V}$	-	0	1	μA
SU input						
$V_{startup}$	start-up voltage	$V_{VDD} = 12\text{ V}$	1	1.3	1.5	V
V_{hys}	hysteresis voltage	$V_{VDD} = 12\text{ V}$	-	100	-	mV
I_I	input current	$V_{VDD} = 12\text{ V}$	-	0	1	μA
CLK input						
$V_{IH(CLK)}$	HIGH-level input voltage on pin CLK	$V_{SS(CLK)} = 0\text{ V}$; $V_{DD(CLK)} = 12\text{ V}$	0.9	1.6	2.7	V

Table 6. Characteristics ...continued

$T_j = -40\text{ }^\circ\text{C}$ to $125\text{ }^\circ\text{C}$; all voltages are measured with respect to signal ground (pin 14); currents are positive when flowing into the IC, Unless otherwise specified.

Symbol	Parameter	Conditions	Min	Typ	Max	Unit
V_{hys}	hysteresis voltage	$V_{SS(CLK)} = 0\text{ V}$; $V_{DD(CLK)} = 12\text{ V}$	-	100		mV
I_I	input current		-	0	1	μA
f_{bridge}	bridge frequency	$V_{RC} = 0\text{ V}$	-	-	200	kHz
supply for CLK						
$I_{DD(CLK)}$	CLK supply current	$V_{SS(CLK)} = 0\text{ V}$; $V_{DD(CLK)} = 14\text{ V}$	-	420	625	μA
$V_{DD(CLK)}$	CLK supply voltage	$V_{SS(CLK)} = 0\text{ V}$	5.75	-	14	V
BD input						
V_{BD}	voltage on pin BD		1.23	1.29	1.35	V
I_I	input current		-	0	1	μA
Internal oscillator						
$f_{osc(int)}$	internal oscillator frequency	$V_{CLK} = 0\text{ V}$; $V_{SS(CLK)} = 0\text{ V}$	-	-	100	kHz
K_{osc}	oscillator constant	$f_{bridge} = 500\text{ Hz}$	0.89	0.97	1.05	

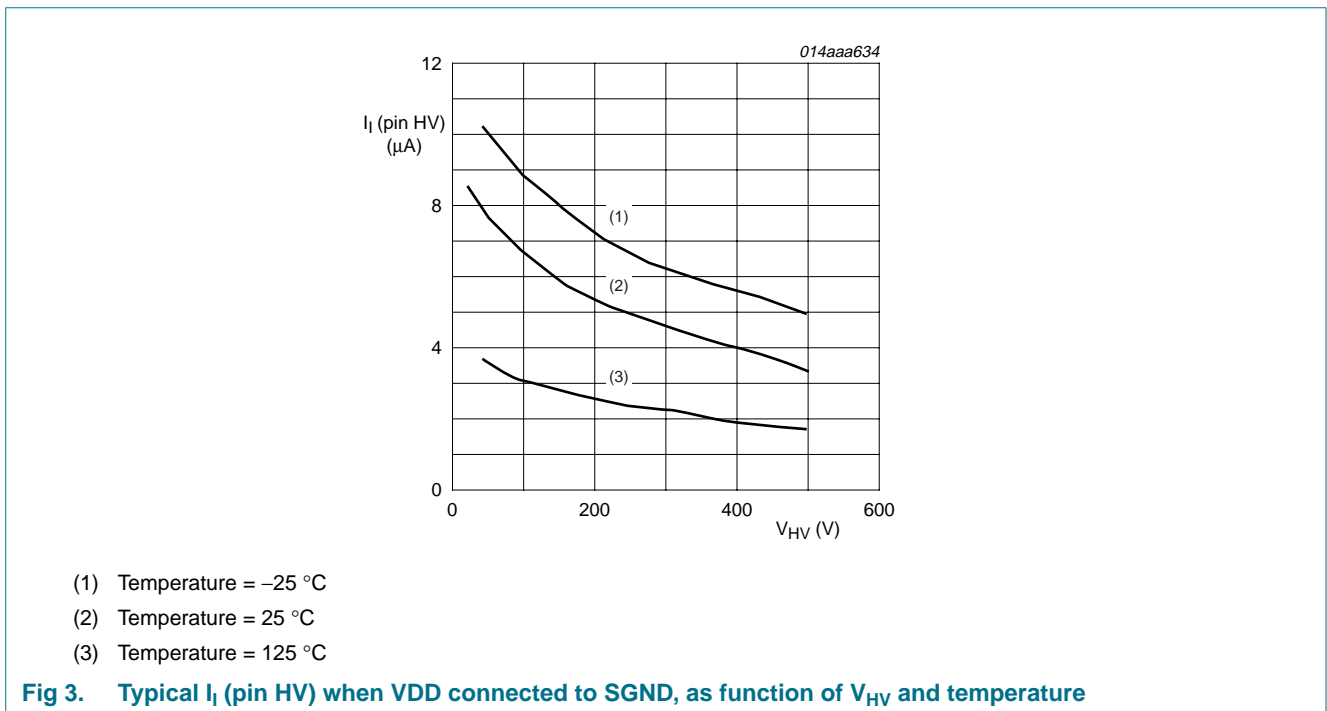

11. Quality information

This product has been qualified to the appropriate Automotive Electronics Council (AEC) standard Q100 and Q101 and is suitable for use in automotive critical applications.

12. Package outline

SSOP28: plastic shrink small outline package; 28 leads; body width 5.3 mm

SOT341-1

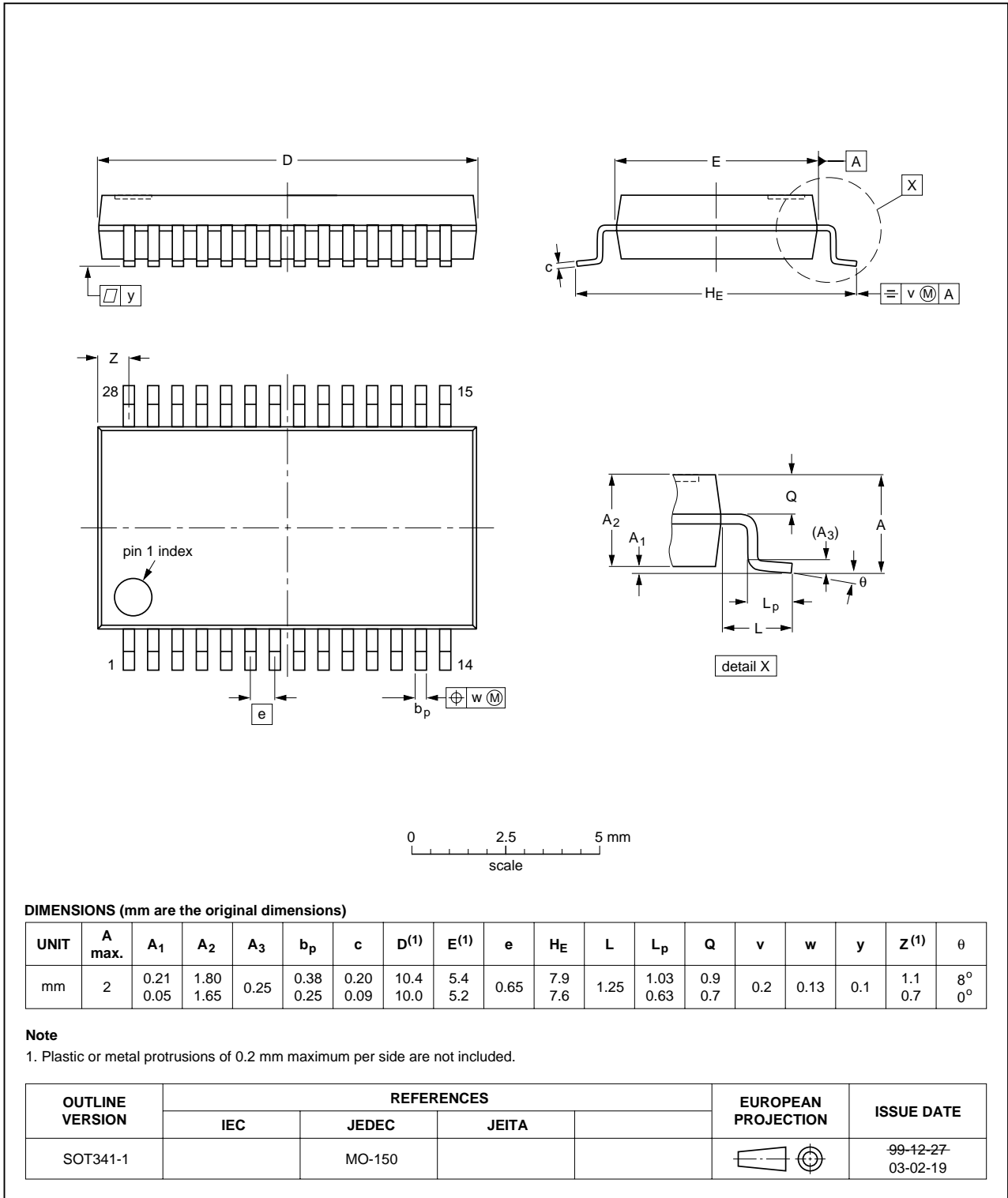

Fig 4. Package outline SSOP28 (SOT134-1)

13. Revision history

Table 7. Revision history

Document ID	Release date	Data sheet status	Change notice	Supersedes
UBA2036TS_1	20081030	Product data sheet	-	-

14. Legal information

14.1 Data sheet status

Document status ^{[1][2]}	Product status ^[3]	Definition
Objective [short] data sheet	Development	This document contains data from the objective specification for product development.
Preliminary [short] data sheet	Qualification	This document contains data from the preliminary specification.
Product [short] data sheet	Production	This document contains the product specification.

[1] Please consult the most recently issued document before initiating or completing a design.

[2] The term 'short data sheet' is explained in section "Definitions".

[3] The product status of device(s) described in this document may have changed since this document was published and may differ in case of multiple devices. The latest product status information is available on the Internet at URL <http://www.nxp.com>.

14.2 Definitions

Draft — The document is a draft version only. The content is still under internal review and subject to formal approval, which may result in modifications or additions. NXP Semiconductors does not give any representations or warranties as to the accuracy or completeness of information included herein and shall have no liability for the consequences of use of such information.

Short data sheet — A short data sheet is an extract from a full data sheet with the same product type number(s) and title. A short data sheet is intended for quick reference only and should not be relied upon to contain detailed and full information. For detailed and full information see the relevant full data sheet, which is available on request via the local NXP Semiconductors sales office. In case of any inconsistency or conflict with the short data sheet, the full data sheet shall prevail.

14.3 Disclaimers

General — Information in this document is believed to be accurate and reliable. However, NXP Semiconductors does not give any representations or warranties, expressed or implied, as to the accuracy or completeness of such information and shall have no liability for the consequences of use of such information.

Right to make changes — NXP Semiconductors reserves the right to make changes to information published in this document, including without limitation specifications and product descriptions, at any time and without notice. This document supersedes and replaces all information supplied prior to the publication hereof.

Suitability for use — NXP Semiconductors products are not designed, authorized or warranted to be suitable for use in medical, military, aircraft, space or life support equipment, nor in applications where failure or malfunction of an NXP Semiconductors product can reasonably be expected to result in personal injury, death or severe property or environmental

damage. NXP Semiconductors accepts no liability for inclusion and/or use of NXP Semiconductors products in such equipment or applications and therefore such inclusion and/or use is at the customer's own risk.

Applications — Applications that are described herein for any of these products are for illustrative purposes only. NXP Semiconductors makes no representation or warranty that such applications will be suitable for the specified use without further testing or modification.

Quick reference data — The Quick reference data is an extract of the product data given in the Limiting values and Characteristics sections of this document, and as such is not complete, exhaustive or legally binding.

Limiting values — Stress above one or more limiting values (as defined in the Absolute Maximum Ratings System of IEC 60134) may cause permanent damage to the device. Limiting values are stress ratings only and operation of the device at these or any other conditions above those given in the Characteristics sections of this document is not implied. Exposure to limiting values for extended periods may affect device reliability.

Terms and conditions of sale — NXP Semiconductors products are sold subject to the general terms and conditions of commercial sale, as published at <http://www.nxp.com/profile/terms>, including those pertaining to warranty, intellectual property rights infringement and limitation of liability, unless explicitly otherwise agreed to in writing by NXP Semiconductors. In case of any inconsistency or conflict between information in this document and such terms and conditions, the latter will prevail.

No offer to sell or license — Nothing in this document may be interpreted or construed as an offer to sell products that is open for acceptance or the grant, conveyance or implication of any license under any copyrights, patents or other industrial or intellectual property rights.

14.4 Trademarks

Notice: All referenced brands, product names, service names and trademarks are the property of their respective owners.

15. Contact information

For more information, please visit: <http://www.nxp.com>

For sales office addresses, please send an email to: salesaddresses@nxp.com

16. Contents

1 General description 1

2 Features 1

3 Applications 1

4 Ordering information 1

5 Block diagram 2

6 Pinning information 3

6.1 Pinning 3

6.2 Pin description 3

7 Functional description 4

7.1 Supply voltage 4

7.2 Start-up. 4

7.3 Oscillation state 4

7.4 Non-overlap time 5

7.5 Start-up delay 5

7.6 Bridge disable. 5

8 Limiting values. 6

9 Thermal characteristics. 7

10 Characteristics. 7

11 Quality information 9

12 Package outline 10

13 Revision history. 11

14 Legal information. 12

14.1 Data sheet status 12

14.2 Definitions 12

14.3 Disclaimers 12

14.4 Trademarks 12

15 Contact information. 12

16 Contents 13

Please be aware that important notices concerning this document and the product(s) described herein, have been included in section 'Legal information'.

