

uA9638C DUAL HIGH-SPEED DIFFERENTIAL LINE DRIVER

SLLS112C – OCTOBER 1980 – REVISED APRIL 1994

- **Meets or Exceeds ANSI Standard EIA/TIA-422-B**
- **Operates From a Single 5-V Power Supply**
- **Drives Loads as Low as 50 Ω up to 15 Mbps**
- **TTL- and CMOS-Input Compatibility**
- **Output Short-Circuit Protection**
- **Interchangeable With National Semiconductor™ DS9638**

**D OR P PACKAGE
(TOP VIEW)**

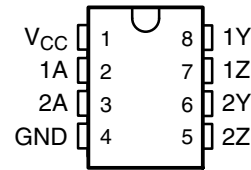

description

The uA9638C is a dual high-speed differential line driver designed to meet ANSI Standard EIA/TIA-422-B. The inputs are TTL and CMOS compatible and have input clamp diodes. Schottky-diode-clamped transistors are used to minimize propagation delay time. This device operates from a single 5-V power supply and is supplied in an 8-pin package.

The uA9638 provides the current needed to drive low-impedance loads at high speeds. Typically used with twisted-pair cabling and differential receiver(s), base-band data transmission can be accomplished up to and exceeding 15 Mbps in properly designed systems. The uA9637A dual line receiver is commonly used as the receiver. For even faster switching speeds in the same pin configuration, see the SN75ALS191.

The uA9638C is characterized for operation from 0°C to 70°C.

logic symbol†

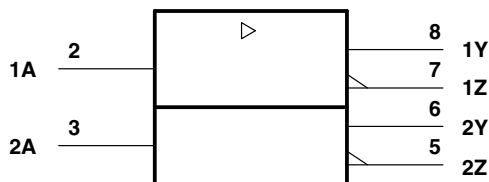

logic diagram

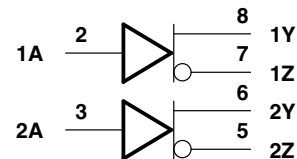

† This symbol is in accordance with ANSI/IEEE Std 91-1984 and IEC Publication 617-12.



Please be aware that an important notice concerning availability, standard warranty, and use in critical applications of Texas Instruments semiconductor products and disclaimers thereto appears at the end of this data sheet.

National Semiconductor is a trademark of National Semiconductor Corporation.

PRODUCTION DATA information is current as of publication date. Products conform to specifications per the terms of Texas Instruments standard warranty. Production processing does not necessarily include testing of all parameters.

**TEXAS
INSTRUMENTS**

POST OFFICE BOX 655303 • DALLAS, TEXAS 75265

Copyright © 1994, Texas Instruments Incorporated

uA9638C DUAL HIGH-SPEED DIFFERENTIAL LINE DRIVER

SLLS112C – OCTOBER 1980 – REVISED APRIL 1994

schematics of inputs and outputs

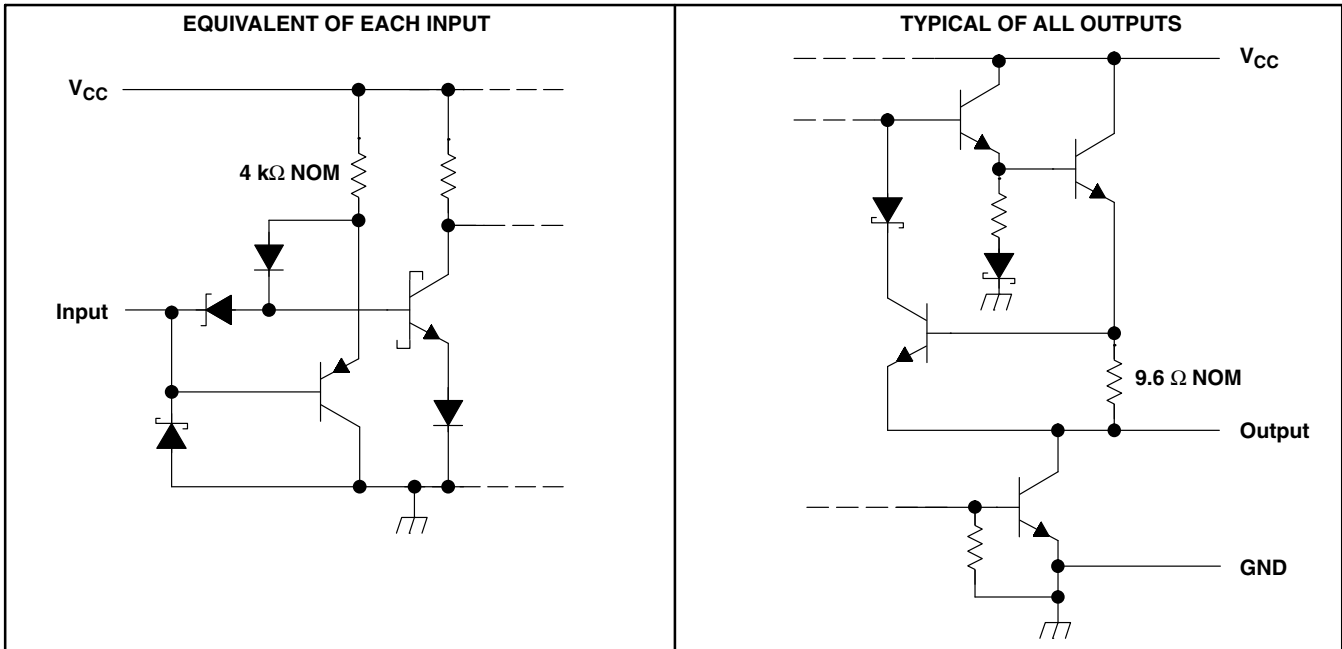

absolute maximum ratings over operating free-air temperature range (unless otherwise noted)†

Supply voltage range, V _{CC} (see Note 1)	-0.5 V to 7 V
Input voltage range, V _I	-0.5 V to 7 V
Continuous total power dissipation	See Dissipation Rating Table
Operating free-air temperature range, T _A	0°C to 70°C
Storage temperature range, T _{stg}	-65°C to 150°C
Lead temperature 1,6 mm (1/16 inch) from 10 seconds	260°C

† Stresses beyond those listed under "absolute maximum ratings" may cause permanent damage to the device. These are stress ratings only, and functional operation of the device at these or any other conditions beyond those indicated under "recommended operating conditions" is not implied. Exposure to absolute-maximum-rated conditions for extended periods may affect device reliability.

NOTE 1: Voltage values except differential output voltages are with respect to network GND.

DISSIPATION RATING TABLE

PACKAGE	T _A = 25°C POWER RATING	DERATING FACTOR ABOVE T _A = 25°C	T _A = 70°C POWER RATING
D	725 mW	5.8 mW/°C	464 mW
P	1000 mW	8.0 mW/°C	640 mW

recommended operating conditions

	MIN	NOM	MAX	UNIT
Supply voltage, V _{CC}	4.75	5	5.25	V
High-level input voltage, V _{IH}	2			V
Low-level input voltage, V _{IL}			0.8	V
High-level output current, I _{OH}			-50	mA
Low-level output current, I _{OL}			50	mA
Operating free-air temperature, T _A	0		70	°C



POST OFFICE BOX 655303 • DALLAS, TEXAS 75265

uA9638C DUAL HIGH-SPEED DIFFERENTIAL LINE DRIVER

SLLS112C – OCTOBER 1980 – REVISED APRIL 1994

electrical characteristics over operating free-air temperature range (unless otherwise noted)

PARAMETER		TEST CONDITIONS			MIN	TYP†	MAX	UNIT	
V_{IK}	Input clamp voltage	$V_{CC} = 4.75\text{ V}$, $I_I = -18\text{ mA}$			-1	-1.2		V	
V_{OH}	High-level output voltage	$V_{CC} = 4.75\text{ V}$, $V_{IL} = 0.8\text{ V}$	$V_{IH} = 2\text{ V}$,	$I_{OH} = -10\text{ mA}$	2.5	3.5		V	
				$I_{OH} = -40\text{ mA}$	2				
V_{OL}	Low-level output voltage	$V_{CC} = 4.75\text{ V}$, $I_{OL} = 40\text{ mA}$	$V_{IH} = 2\text{ V}$,	$V_{IL} = 0.8\text{ V}$,			0.5	V	
$ V_{OD1} $	Magnitude of differential output voltage	$V_{CC} = 5.25\text{ V}$, $I_O = 0$					$2V_{OD2}$	V	
$ V_{OD2} $	Magnitude of differential output voltage				2			V	
$\Delta V_{OD} $	Change in magnitude of differential output voltage‡	$V_{CC} = 4.75\text{ V to }5.25\text{ V}$, See Figure 1			$R_L = 100\ \Omega$,			± 0.4	V
V_{OC}	Common-mode output voltage§							3	V
$\Delta V_{OC} $	Change in magnitude of common-mode output voltage‡							± 0.4	V
I_O	Output current with power off	$V_{CC} = 0$	$V_O = 6\text{ V}$		0.1	100		μA	
			$V_O = -0.25\text{ V}$		-0.1	-100			
			$V_O = -0.25\text{ V to }6\text{ V}$		± 100				
I_I	Input current	$V_{CC} = 5.25\text{ V}$, $V_I = 5.5\text{ V}$					50	μA	
I_{IH}	High-level input current	$V_{CC} = 5.25\text{ V}$, $V_I = 2.7\text{ V}$					25	μA	
I_{IL}	Low-level input current	$V_{CC} = 5.25\text{ V}$, $V_I = 0.5\text{ V}$					-200	μA	
I_{OS}	Short-circuit output current¶	$V_{CC} = 5.25\text{ V}$, $V_O = 0$			-50		-150	mA	
I_{CC}	Supply current (both drivers)	$V_{CC} = 5.25\text{ V}$, No load, All inputs at 0 V			45		65	mA	

† All typical values are at $V_{CC} = 5\text{ V}$ and $T_A = 25^\circ\text{C}$.

‡ $\Delta|V_{OD}|$ and $\Delta|V_{OC}|$ are the changes in magnitude of V_{OD} and V_{OC} , respectively, that occur when the input is changed from a high level to a low level or vice versa.

§ In Standard EIA-422-A, V_{OC} , which is the average of the two output voltages with respect to ground, is called output offset voltage, V_{OS} .

¶ Only one output at a time should be shorted, and duration of the short circuit should not exceed one second.

switching characteristics, $V_{CC} = 5\text{ V}$, $T_A = 25^\circ\text{C}$

PARAMETER		TEST CONDITIONS			MIN	TYP	MAX	UNIT
$t_{d(OD)}$	Differential output delay time	$C_L = 15\text{ pF}$,	$R_L = 100\ \Omega$,	See Figure 2		10	20	ns
$t_{t(OD)}$	Differential output transition time					10	20	ns
$t_{sk(o)}$	Output skew	See Figure 2				1		ns



uA9638C DUAL HIGH-SPEED DIFFERENTIAL LINE DRIVER

SLLS112C – OCTOBER 1980 – REVISED APRIL 1994

PARAMETER MEASUREMENT INFORMATION

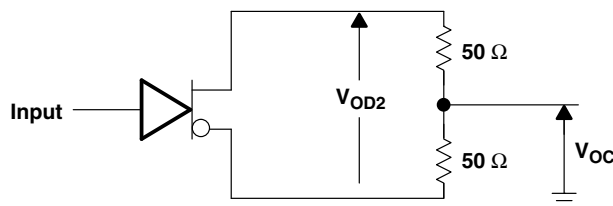
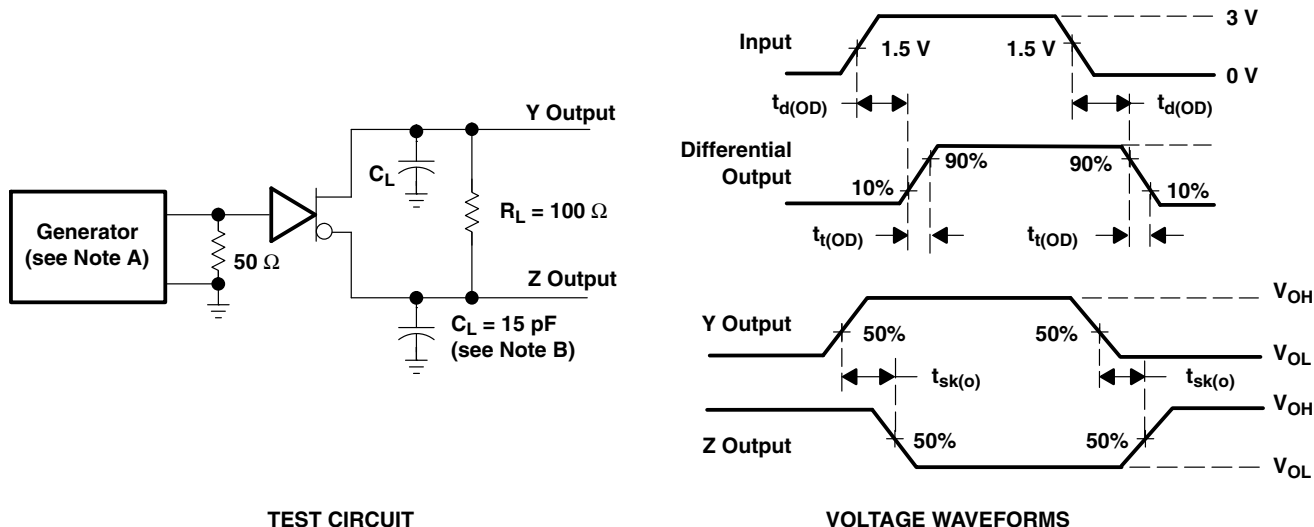

Figure 1. Differential and Common-Mode Output Voltages



TEST CIRCUIT

VOLTAGE WAVEFORMS

NOTES: A. The input pulse generator has the following characteristics: $Z_O = 50 \Omega$, $PRR \leq 500 \text{ kHz}$, $t_w = 100 \text{ ns}$, $t_r = \leq 5 \text{ ns}$.
B. C_L includes probe and jig capacitance.

Figure 2. Test Circuit and Voltage Waveforms

PACKAGING INFORMATION

Orderable Device	Status ⁽¹⁾	Package Type	Package Drawing	Pins	Package Qty	Eco Plan ⁽²⁾	Lead/ Ball Finish	MSL Peak Temp ⁽³⁾	Samples (Requires Login)
UA9638CD	ACTIVE	SOIC	D	8	75	Green (RoHS & no Sb/Br)	CU NIPDAU	Level-2-260C-1 YEAR	Add to cart
UA9638CDE4	ACTIVE	SOIC	D	8	75	Green (RoHS & no Sb/Br)	CU NIPDAU	Level-2-260C-1 YEAR	Add to cart
UA9638CDG4	ACTIVE	SOIC	D	8	75	Green (RoHS & no Sb/Br)	CU NIPDAU	Level-2-260C-1 YEAR	Add to cart
UA9638CDR	ACTIVE	SOIC	D	8	2500	Green (RoHS & no Sb/Br)	CU NIPDAU	Level-2-260C-1 YEAR	Add to cart
UA9638CDRE4	ACTIVE	SOIC	D	8	2500	Green (RoHS & no Sb/Br)	CU NIPDAU	Level-2-260C-1 YEAR	Add to cart
UA9638CDRG4	ACTIVE	SOIC	D	8	2500	Green (RoHS & no Sb/Br)	CU NIPDAU	Level-2-260C-1 YEAR	Add to cart
UA9638CP	ACTIVE	PDIP	P	8	50	Pb-Free (RoHS)	CU NIPDAU	N / A for Pkg Type	Add to cart
UA9638CPE4	ACTIVE	PDIP	P	8	50	Pb-Free (RoHS)	CU NIPDAU	N / A for Pkg Type	Add to cart

⁽¹⁾ The marketing status values are defined as follows:

ACTIVE: Product device recommended for new designs.

LIFEBUY: TI has announced that the device will be discontinued, and a lifetime-buy period is in effect.

NRND: Not recommended for new designs. Device is in production to support existing customers, but TI does not recommend using this part in a new design.

PREVIEW: Device has been announced but is not in production. Samples may or may not be available.

OBSELETE: TI has discontinued the production of the device.

⁽²⁾ Eco Plan - The planned eco-friendly classification: Pb-Free (RoHS), Pb-Free (RoHS Exempt), or Green (RoHS & no Sb/Br) - please check <http://www.ti.com/productcontent> for the latest availability information and additional product content details.

TBD: The Pb-Free/Green conversion plan has not been defined.

Pb-Free (RoHS): TI's terms "Lead-Free" or "Pb-Free" mean semiconductor products that are compatible with the current RoHS requirements for all 6 substances, including the requirement that lead not exceed 0.1% by weight in homogeneous materials. Where designed to be soldered at high temperatures, TI Pb-Free products are suitable for use in specified lead-free processes.

Pb-Free (RoHS Exempt): This component has a RoHS exemption for either 1) lead-based flip-chip solder bumps used between the die and package, or 2) lead-based die adhesive used between the die and leadframe. The component is otherwise considered Pb-Free (RoHS compatible) as defined above.

Green (RoHS & no Sb/Br): TI defines "Green" to mean Pb-Free (RoHS compatible), and free of Bromine (Br) and Antimony (Sb) based flame retardants (Br or Sb do not exceed 0.1% by weight in homogeneous material)

⁽³⁾ MSL, Peak Temp. -- The Moisture Sensitivity Level rating according to the JEDEC industry standard classifications, and peak solder temperature.

Important Information and Disclaimer: The information provided on this page represents TI's knowledge and belief as of the date that it is provided. TI bases its knowledge and belief on information provided by third parties, and makes no representation or warranty as to the accuracy of such information. Efforts are underway to better integrate information from third parties. TI has taken and

continues to take reasonable steps to provide representative and accurate information but may not have conducted destructive testing or chemical analysis on incoming materials and chemicals. TI and TI suppliers consider certain information to be proprietary, and thus CAS numbers and other limited information may not be available for release.

In no event shall TI's liability arising out of such information exceed the total purchase price of the TI part(s) at issue in this document sold by TI to Customer on an annual basis.

OTHER QUALIFIED VERSIONS OF UA9638 :

- Enhanced Product: [UA9638-EP](#)

NOTE: Qualified Version Definitions:

- Enhanced Product - Supports Defense, Aerospace and Medical Applications

TAPE AND REEL INFORMATION



QUADRANT ASSIGNMENTS FOR PIN 1 ORIENTATION IN TAPE



*All dimensions are nominal

Device	Package Type	Package Drawing	Pins	SPQ	Reel Diameter (mm)	Reel Width W1 (mm)	A0 (mm)	B0 (mm)	K0 (mm)	P1 (mm)	W (mm)	Pin1 Quadrant
UA9638CDR	SOIC	D	8	2500	330.0	12.4	6.4	5.2	2.1	8.0	12.0	Q1

TAPE AND REEL BOX DIMENSIONS

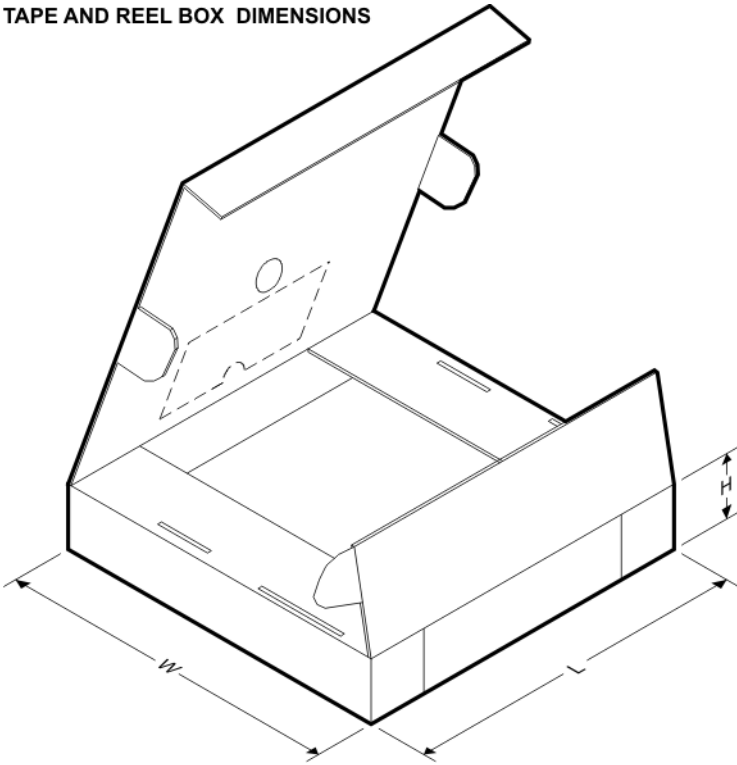

*All dimensions are nominal

Device	Package Type	Package Drawing	Pins	SPQ	Length (mm)	Width (mm)	Height (mm)
UA9638CDR	SOIC	D	8	2500	340.5	338.1	20.6

P (R-PDIP-T8)

PLASTIC DUAL-IN-LINE PACKAGE



- NOTES:
- A. All linear dimensions are in inches (millimeters).
 - B. This drawing is subject to change without notice.
 - C. Falls within JEDEC MS-001 variation BA.

D (R-PDSO-G8)

PLASTIC SMALL OUTLINE



NOTES: A. All linear dimensions are in inches (millimeters).
 B. This drawing is subject to change without notice.
 C. Body length does not include mold flash, protrusions, or gate burrs. Mold flash, protrusions, or gate burrs shall not exceed 0.006 (0,15) each side.
 D. Body width does not include interlead flash. Interlead flash shall not exceed 0.017 (0,43) each side.
 E. Reference JEDEC MS-012 variation AA.

D (R-PDSO-G8)

PLASTIC SMALL OUTLINE



- NOTES:
- All linear dimensions are in millimeters.
 - This drawing is subject to change without notice.
 - Publication IPC-7351 is recommended for alternate designs.
 - Laser cutting apertures with trapezoidal walls and also rounding corners will offer better paste release. Customers should contact their board assembly site for stencil design recommendations. Refer to IPC-7525 for other stencil recommendations.
 - Customers should contact their board fabrication site for solder mask tolerances between and around signal pads.

IMPORTANT NOTICE

Texas Instruments Incorporated and its subsidiaries (TI) reserve the right to make corrections, enhancements, improvements and other changes to its semiconductor products and services per JESD46C and to discontinue any product or service per JESD48B. Buyers should obtain the latest relevant information before placing orders and should verify that such information is current and complete. All semiconductor products (also referred to herein as "components") are sold subject to TI's terms and conditions of sale supplied at the time of order acknowledgment.

TI warrants performance of its components to the specifications applicable at the time of sale, in accordance with the warranty in TI's terms and conditions of sale of semiconductor products. Testing and other quality control techniques are used to the extent TI deems necessary to support this warranty. Except where mandated by applicable law, testing of all parameters of each component is not necessarily performed.

TI assumes no liability for applications assistance or the design of Buyers' products. Buyers are responsible for their products and applications using TI components. To minimize the risks associated with Buyers' products and applications, Buyers should provide adequate design and operating safeguards.

TI does not warrant or represent that any license, either express or implied, is granted under any patent right, copyright, mask work right, or other intellectual property right relating to any combination, machine, or process in which TI components or services are used. Information published by TI regarding third-party products or services does not constitute a license to use such products or services or a warranty or endorsement thereof. Use of such information may require a license from a third party under the patents or other intellectual property of the third party, or a license from TI under the patents or other intellectual property of TI.

Reproduction of significant portions of TI information in TI data books or data sheets is permissible only if reproduction is without alteration and is accompanied by all associated warranties, conditions, limitations, and notices. TI is not responsible or liable for such altered documentation. Information of third parties may be subject to additional restrictions.

Resale of TI components or services with statements different from or beyond the parameters stated by TI for that component or service voids all express and any implied warranties for the associated TI component or service and is an unfair and deceptive business practice. TI is not responsible or liable for any such statements.

Buyer acknowledges and agrees that it is solely responsible for compliance with all legal, regulatory and safety-related requirements concerning its products, and any use of TI components in its applications, notwithstanding any applications-related information or support that may be provided by TI. Buyer represents and agrees that it has all the necessary expertise to create and implement safeguards which anticipate dangerous consequences of failures, monitor failures and their consequences, lessen the likelihood of failures that might cause harm and take appropriate remedial actions. Buyer will fully indemnify TI and its representatives against any damages arising out of the use of any TI components in safety-critical applications.

In some cases, TI components may be promoted specifically to facilitate safety-related applications. With such components, TI's goal is to help enable customers to design and create their own end-product solutions that meet applicable functional safety standards and requirements. Nonetheless, such components are subject to these terms.

No TI components are authorized for use in FDA Class III (or similar life-critical medical equipment) unless authorized officers of the parties have executed a special agreement specifically governing such use.

Only those TI components which TI has specifically designated as military grade or "enhanced plastic" are designed and intended for use in military/aerospace applications or environments. Buyer acknowledges and agrees that any military or aerospace use of TI components which have **not** been so designated is solely at the Buyer's risk, and that Buyer is solely responsible for compliance with all legal and regulatory requirements in connection with such use.

TI has specifically designated certain components which meet ISO/TS16949 requirements, mainly for automotive use. Components which have not been so designated are neither designed nor intended for automotive use; and TI will not be responsible for any failure of such components to meet such requirements.

Products

Audio	www.ti.com/audio
Amplifiers	amplifier.ti.com
Data Converters	dataconverter.ti.com
DLP® Products	www.dlp.com
DSP	dsp.ti.com
Clocks and Timers	www.ti.com/clocks
Interface	interface.ti.com
Logic	logic.ti.com
Power Mgmt	power.ti.com
Microcontrollers	microcontroller.ti.com
RFID	www.ti-rfid.com
OMAP Mobile Processors	www.ti.com/omap
Wireless Connectivity	www.ti.com/wirelessconnectivity

Applications

Automotive and Transportation	www.ti.com/automotive
Communications and Telecom	www.ti.com/communications
Computers and Peripherals	www.ti.com/computers
Consumer Electronics	www.ti.com/consumer-apps
Energy and Lighting	www.ti.com/energy
Industrial	www.ti.com/industrial
Medical	www.ti.com/medical
Security	www.ti.com/security
Space, Avionics and Defense	www.ti.com/space-avionics-defense
Video and Imaging	www.ti.com/video

TI E2E Community e2e.ti.com