

## 4-PORT HUB FOR THE UNIVERSAL SERIAL BUS WITH OPTIONAL SERIAL EEPROM INTERFACE

Check for Samples: [TUSB2046B](#), [TUSB2046BI](#)

### FEATURES

- Fully Compliant With the USB Specification as a Full-Speed Hub: TID #30220231
- 32-Terminal LQFP <sup>(1)</sup> Package With a 0.8-mm Terminal Pitch or QFN Package with a 0.5-mm Terminal Pitch
- 3.3-V Low Power ASIC Logic
- Integrated USB Transceivers
- State Machine Implementation Requires No Firmware Programming
- One Upstream Port and Four Downstream Ports
- All Downstream Ports Support Full-Speed and Low-Speed Operations
- Two Power Source Modes
  - Self-Powered Mode
  - Bus-Powered Mode
- Power Switching and Overcurrent Reporting Is Provided Ganged or Per Port
- Supports Suspend and Resume Operations
- Supports Programmable Vendor ID and Product ID With External Serial EEPROM
- 3-State EEPROM Interface Allows EEPROM Sharing
- Push-Pull Outputs for  $\overline{\text{PWRON}}$  Eliminate the Need for External Pullup Resistors
- Noise Filtering on  $\overline{\text{OVRCUR}}$  Provides Immunity to Voltage Spikes
- Package Pinout Allows 2-Layer PCB
- Low EMI Emission Achieved by a 6-MHz Crystal Input
- Migrated From Proven TUSB2040 Hub
- Lower Cost Than the TUSB2040 Hub
- Enhanced System ESD Performance
- No Special Driver Requirements; Works Seamlessly With Any Operating System With USB Stack Support
- Supports 6-MHz Operation Through a Crystal Input or a 48-MHz Input Clock

(1) JEDEC descriptor S-PQFP-G for low profile quad flat pack (LQFP).

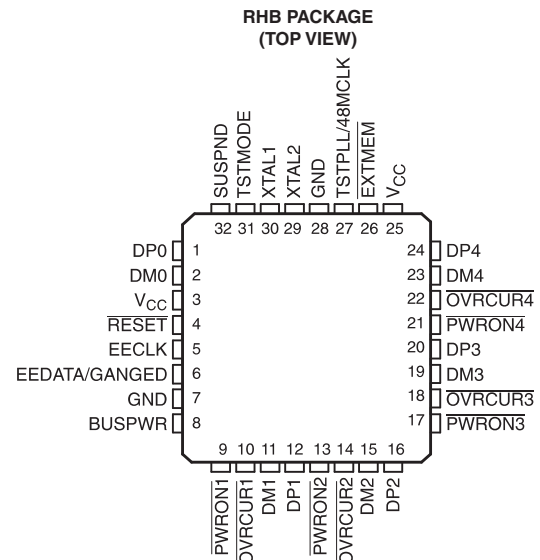
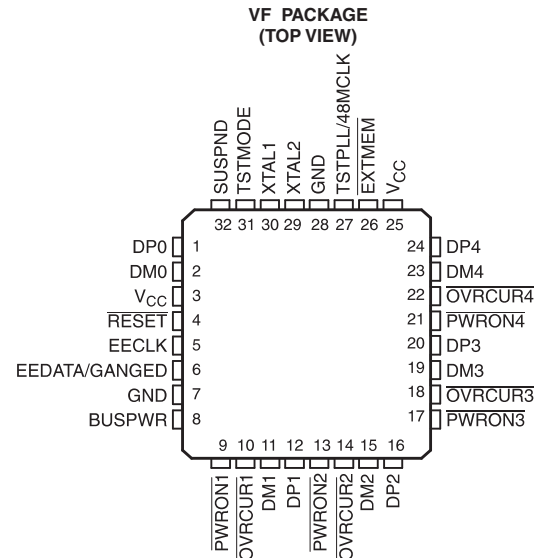

Please be aware that an important notice concerning availability, standard warranty, and use in critical applications of Texas Instruments semiconductor products and disclaimers thereto appears at the end of this data sheet.

## DESCRIPTION/ORDERING INFORMATION

The TUSB2046B is a 3.3-V CMOS hub device that provides one upstream port and four downstream ports in compliance with the Universal Serial Bus (USB) specification as a full-speed hub. Because this device is implemented with a digital state machine instead of a microcontroller, no firmware programming is required. Fully-compliant USB transceivers are integrated into the ASIC for all upstream and downstream ports. The downstream ports support both full-speed and low-speed devices by automatically setting the slew rate according to the speed of the device attached to the ports. The configuration of the BUSPWR terminal selects either the bus-powered or the self-powered mode.

Configuring the GANGED input determines the power switching and overcurrent detection modes for the downstream ports. External power-management devices, such as the TPS2044, are required to control the 5-V source to the downstream ports according to the corresponding values of the  $\overline{\text{PWRON}}$  terminal. Upon detecting any overcurrent conditions, the power-management device sets the corresponding  $\overline{\text{OVRCUR}}$  terminal of the TUSB2046B to a logic low. If GANGED is high, all  $\overline{\text{PWRON}}$  outputs switch together and if any  $\overline{\text{OVRCUR}}$  is activated, all ports transition to the power-off state. If GANGED is low, the  $\overline{\text{PWRON}}$  outputs and  $\overline{\text{OVRCUR}}$  inputs operate on a per-port basis.

The TUSB2046B provides the flexibility of using a 6-MHz or a 48-MHz clock. The logic level of the TSTMODE terminal controls the selection of the clock source. When TSTMODE is low, the output of the internal APLL circuitry is selected to drive the internal core of the device. When TSTMODE is high, the TSTPLL/48MCLK input is selected as the input clock source and the APLL circuitry is powered down and bypassed. The internal oscillator cell is also powered down while TSTMODE is high.

Low EMI emission is achieved because the TUSB2046B is able to utilize a 6-MHz crystal input. Connect the crystal as shown in Figure 6. An internal PLL then generates the 48-MHz clock used to sample data from the upstream port and to synchronize the 12 MHz used for the USB clock. If low-power suspend and resume are desired, a passive crystal or resonator must be used. However, a 6-MHz oscillator may be used by connecting the output to the XTAL1 terminal and leaving the XTAL2 terminal open. The oscillator TTL output must not exceed 3.6 V.

For 48-MHz operation, the clock cannot be generated with a crystal using the XTAL2 output because the internal oscillator cell supports only the fundamental frequency.

See Figure 7 and Figure 8 in the *input clock configuration* section for more detailed information regarding the input clock configuration.

The  $\overline{\text{EXTMEM}}$  terminal enables or disables the optional EEPROM interface. When the  $\overline{\text{EXTMEM}}$  terminal is high, the product ID (PID) displayed during enumeration is the general-purpose USB hub. For this default, terminal 5 is disabled and terminal 6 functions as the GANGED input terminal. If custom PID and vendor ID (VID) descriptors are desired, the  $\overline{\text{EXTMEM}}$  terminal must be low ( $\overline{\text{EXTMEM}} = 0$ ). For this configuration, terminals 5 and 6 function as the EEPROM interface with terminals 5 and 6 functioning as EECLK and EEDATA, respectively. See Table 1 for a description of the EEPROM memory map.

Other useful features of the TUSB2046B include a package with a 0.8-mm terminal pitch for easy PCB routing and assembly, push-pull outputs for the  $\overline{\text{PWRON}}$  terminals eliminate the need for pullup resistors required by traditional open-collector I/Os, and  $\overline{\text{OVRCUR}}$  terminals have noise filtering for increased immunity to voltage spikes.

ORDERING INFORMATION

T <sub>A</sub>	PACKAGE <sup>(1)</sup>	ORDERABLE PART NUMBER	TOP-SIDE MARKING
0°C to 70°C	LQFP – VF	Reel of 250	TUSB2046BVF
			TUSB2046BVFG4
		Reel of 1000	TUSB2046BVFR
			TUSB2046BVFRG4
–40°C to 85°C	LQFP – VF	Reel of 1000	TUSB2046BIVFR
			TUSB2046BIVFRG4
	QFN – RHB	Reel of 250	TUSB2046BIRHB
		Reel of 3000	TUSB2046BIRHBR
		Reel of 250	TUSB2046BIRHBT

(1) For the most current package and ordering information, see the Package Option Addendum at the end of this document, or see the TI website at [www.ti.com](http://www.ti.com).

FUNCTIONAL BLOCK DIAGRAM

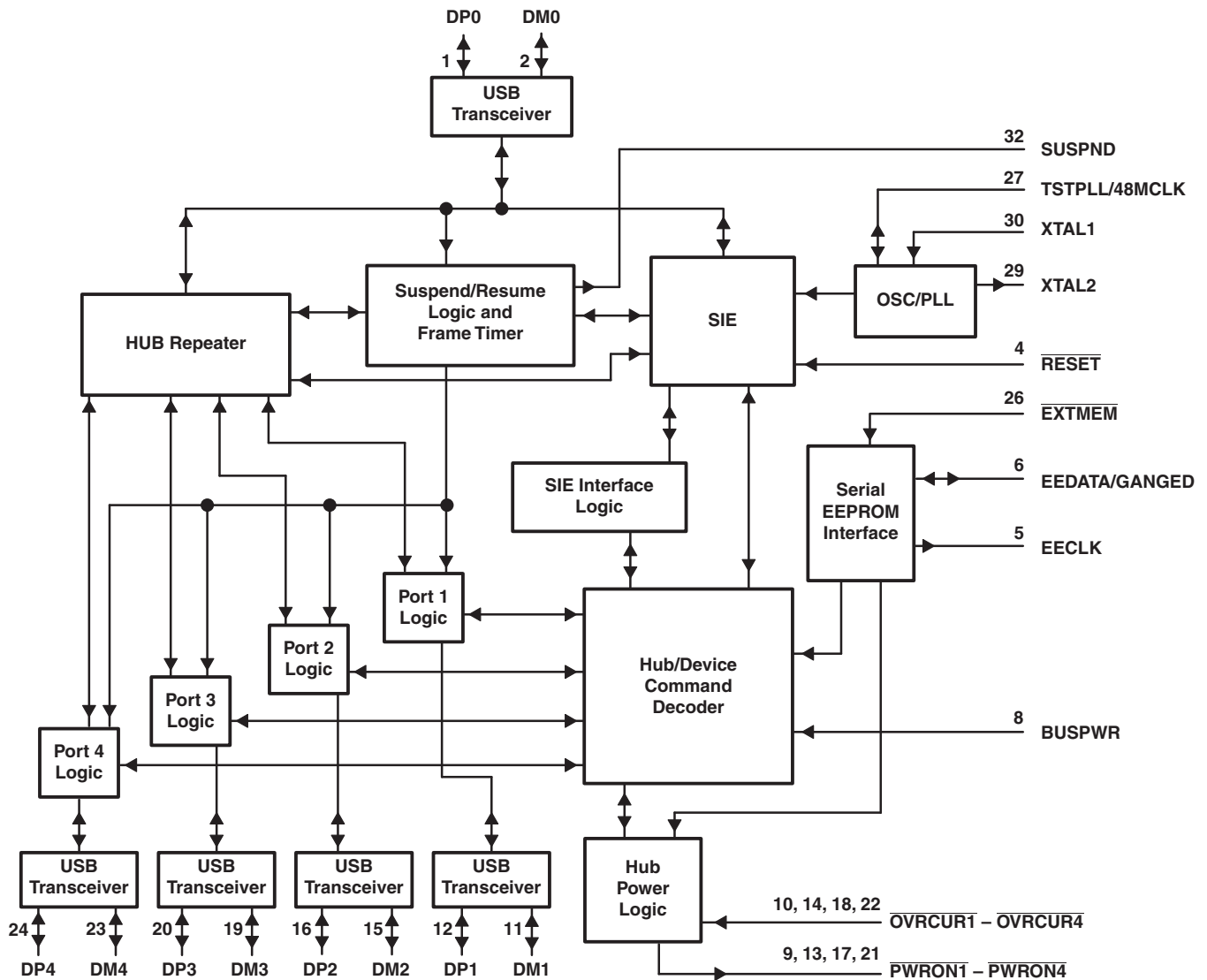

**TERMINAL FUNCTIONS**

TERMINAL		I/O	DESCRIPTION
NAME	NO.		
BUSPWR	8	I	Power source indicator. BUSPWR is an active-high input that indicates whether the downstream ports source their power from the USB cable or a local power supply. For the bus-power mode, this terminal must be pulled to 3.3 V, and for the self-powered mode, this terminal must be pulled low. Input must not change dynamically during operation.
DM0	2	I/O	Root port USB differential data minus. DM0 paired with DP0 constitutes the upstream USB port.
DM1–DM4	11, 15, 19, 23	I/O	USB differential data minus. DM1–DM4 paired with DP1–DP4 support up to four downstream USB ports.
DP0	1	I/O	Root port USB differential data plus. DP0 paired with DM0 constitutes the upstream USB port.
DP1–DP4	12, 16, 20, 24	I/O	USB differential data plus. DP1–DP4 paired with DM1–DM4 support up to four downstream USB ports.
EECLK	5	O	EEPROM serial clock. When $\overline{\text{EXTMEM}}$ is high, the EEPROM interface is disabled. The EECLK terminal is disabled and must be left floating (unconnected). When $\overline{\text{EXTMEM}}$ is low, EECLK acts as a 3-state serial clock output to the EEPROM with a 100- $\mu$ A internal pulldown.
EEDATA/ GANGED	6	I/O	EEPROM serial data/power-management mode indicator. When $\overline{\text{EXTMEM}}$ is high, EEDATA/GANGED selects between ganged or per-port power overcurrent detection for the downstream ports. When $\overline{\text{EXTMEM}}$ is low, EEDATA/GANGED acts as a serial data I/O for the EEPROM and is internally pulled down with a 100- $\mu$ A pulldown. This standard TTL input must not change dynamically during operation.
$\overline{\text{EXTMEM}}$	26	I	When $\overline{\text{EXTMEM}}$ is high, the serial EEPROM interface of the device is disabled. When $\overline{\text{EXTMEM}}$ is low, terminals 5 and 6 are configured as the clock and data terminals of the serial EEPROM interface, respectively.
GND	7, 28		GND terminals must be tied to ground for proper operation.
$\overline{\text{OVRCUR1}}$ – $\overline{\text{OVRCUR4}}$	10, 14, 18, 22	I	Overcurrent input. $\overline{\text{OVRCUR1}}$ – $\overline{\text{OVRCUR4}}$ are active low. For per-port overcurrent detection, one overcurrent input is available for each of the four downstream ports. In the ganged mode, any $\overline{\text{OVRCUR}}$ input may be used and all $\overline{\text{OVRCUR}}$ terminals must be tied together. $\overline{\text{OVRCUR}}$ terminals are active low inputs with noise filtering logic.
$\overline{\text{PWRON1}}$ – $\overline{\text{PWRON4}}$	9, 13, 17, 21	O	Power-on/-off control signals. $\overline{\text{PWRON1}}$ – $\overline{\text{PWRON4}}$ are active low, push-pull outputs. Push-pull outputs eliminate the pullup resistors which open-drain outputs require. However, the external power switches that connect to these terminals must be able to operate with 3.3-V inputs because these outputs cannot drive 5-V signals.
$\overline{\text{RESET}}$	4	I	$\overline{\text{RESET}}$ is an active low TTL input with hysteresis and must be asserted at power up. When $\overline{\text{RESET}}$ is asserted, all logic is initialized. Generally, a reset with a pulse width between 100 $\mu$ s and 1 ms is recommended after 3.3-V $V_{\text{CC}}$ reaches its 90%. Clock signal has to be active during the last 60 $\mu$ s of the reset window.
SUSPND	32	O	Suspend status. SUSPND is an active high output available for external logic power-down operations. During the suspend mode, SUSPND is high. SUSPND is low for normal operation.
TSTMODE	31	I	Test/mode terminal. TSTMODE is used as a test terminal during production testing. This terminal must be tied to ground or 3.3-V $V_{\text{CC}}$ for normal 6-MHz or 48-MHz operation, respectively.
TSTPLL/ 48MCLK	27	I/O	Test/48-MHz clock input. TSTPLL/48MCLK is used as a test terminal during production testing. This terminal must be tied to ground for normal 6-MHz operation. If 48-MHz input clock is desired, a 48-MHz clock source (no crystal) can be connected to this input terminal.
$V_{\text{CC}}$	3, 25		3.3-V supply voltage
XTAL1	30	I	Crystal 1. XTAL1 is a 6-MHz crystal input with 50% duty cycle. An internal PLL generates the 48-MHz and 12-MHz clocks used internally by the ASIC logic.
XTAL2	29	O	Crystal 2. XTAL2 is a 6-MHz crystal output. This terminal must be left open when using an oscillator.

## ABSOLUTE MAXIMUM RATINGS<sup>(1)</sup>

over operating free-air temperature range (unless otherwise noted)

		MIN	MAX	UNIT	
V <sub>CC</sub>	Supply voltage range <sup>(2)</sup>	-0.5	3.6	V	
V <sub>I</sub>	Input voltage range	-0.5	V <sub>CC</sub> + 0.5	V	
V <sub>O</sub>	Output voltage range	-0.5	V <sub>CC</sub> + 0.5	V	
I <sub>IK</sub>	Input clamp current	V <sub>I</sub> < 0 V or V <sub>I</sub> < V <sub>CC</sub>		±20 mA	
I <sub>OK</sub>	Output clamp current	V <sub>O</sub> < 0 V or V <sub>O</sub> < V <sub>CC</sub>		±20 mA	
T <sub>stg</sub>	Storage temperature range	-65	150	°C	
T <sub>A</sub>	Operating free-air temperature range	TUSB2046B	0	70	°C
		TUSB2046BI	-40	85	

- (1) Stresses beyond those listed under “absolute maximum ratings” may cause permanent damage to the device. These are stress ratings only, and functional operation of the device at these or any other conditions beyond those indicated under “recommended operating conditions” is not implied. Exposure to absolute-maximum-rated conditions for extended periods may affect device reliability.
- (2) All voltage levels are with respect to GND.

## RECOMMENDED OPERATING CONDITIONS

PARAMETER		MIN	NOM	MAX	UNIT	
V <sub>CC</sub>	Supply voltage	TUSB2046B	3	3.3	3.6	V
		TUSB2046BI	3.3		3.6	
V <sub>I</sub>	Input voltage, TTL/LVCMOS	0		V <sub>CC</sub>	V	
V <sub>O</sub>	Output voltage, TTL/LVCMOS	0		V <sub>CC</sub>	V	
V <sub>IH(REC)</sub>	High-level input voltage, signal-ended receiver	2		V <sub>CC</sub>	V	
V <sub>IL(REC)</sub>	Low-level input voltage, signal-ended receiver			0.8	V	
V <sub>IH(TTL)</sub>	High-level input voltage, TTL/LVCMOS	2		V <sub>CC</sub>	V	
V <sub>IL(TTL)</sub>	Low-level input voltage, TTL/LVCMOS	0		0.8	V	
T <sub>A</sub>	Operating free-air temperature	TUSB2046B	0	70	°C	
		TUSB2046BI	-40	85		
R <sub>(DRV)</sub>	External series, differential driver resistor	22 (-5%)		22 (5%)	Ω	
f <sub>(OPRH)</sub>	Operating (dc differential driver) high speed mode			12	Mb/s	
f <sub>(OPRL)</sub>	Operating (dc differential driver) low speed mode			1.5	Mb/s	
V <sub>ICR</sub>	Common mode, input range, differential receiver	0.8		2.5	V	
t <sub>t</sub>	Input transition times, TTL/LVCMOS	0		25	ns	
T <sub>J</sub>	Junction temperature range	-40		115	°C	

## THERMAL INFORMATION

THERMAL METRIC <sup>(1)</sup>		TUSB2046BI	UNITS
		RHB	
		32 PINS	
$\theta_{JA}$	Junction-to-ambient thermal resistance <sup>(2)</sup>	35.7	°C/W
$\theta_{JcTop}$	Junction-to-case (top) thermal resistance <sup>(3)</sup>	28.4	
$\theta_{JB}$	Junction-to-board thermal resistance <sup>(4)</sup>	9.9	
$\psi_{JT}$	Junction-to-top characterization parameter <sup>(5)</sup>	0.5	
$\psi_{JB}$	Junction-to-board characterization parameter <sup>(6)</sup>	9.8	
$\theta_{JcBot}$	Junction-to-case (bottom) thermal resistance <sup>(7)</sup>	4.3	

- (1) For more information about traditional and new thermal metrics, see the *IC Package Thermal Metrics* application report, [SPRA953](#).
- (2) The junction-to-ambient thermal resistance under natural convection is obtained in a simulation on a JEDEC-standard, high-K board, as specified in JESD51-7, in an environment described in JESD51-2a.
- (3) The junction-to-case (top) thermal resistance is obtained by simulating a cold plate test on the package top. No specific JEDEC-standard test exists, but a close description can be found in the ANSI SEMI standard G30-88.
- (4) The junction-to-board thermal resistance is obtained by simulating in an environment with a ring cold plate fixture to control the PCB temperature, as described in JESD51-8.
- (5) The junction-to-top characterization parameter,  $\psi_{JT}$ , estimates the junction temperature of a device in a real system and is extracted from the simulation data for obtaining  $\theta_{JA}$ , using a procedure described in JESD51-2a (sections 6 and 7).
- (6) The junction-to-board characterization parameter,  $\psi_{JB}$ , estimates the junction temperature of a device in a real system and is extracted from the simulation data for obtaining  $\theta_{JA}$ , using a procedure described in JESD51-2a (sections 6 and 7).
- (7) The junction-to-case (bottom) thermal resistance is obtained by simulating a cold plate test on the exposed (power) pad. No specific JEDEC standard test exists, but a close description can be found in the ANSI SEMI standard G30-88.

## ELECTRICAL CHARACTERISTICS

over recommended ranges of operating free-air temperature and supply voltage (unless otherwise noted)

PARAMETER		TEST CONDITIONS	MIN	MAX	UNIT	
V <sub>OH</sub>	High-level output voltage	TTL/LVCMOS	I <sub>OH</sub> = -4 mA	V <sub>CC</sub> - 0.5	V	
		USB data lines	R <sub>(DRV)</sub> = 15 kΩ to GND	2.8		
			I <sub>OH</sub> = -12 mA (without R <sub>(DRV)</sub> )	V <sub>CC</sub> - 0.5		
V <sub>OL</sub>	Low-level output voltage	TTL/LVCMOS	I <sub>OL</sub> = 4 mA	0.5	V	
		USB data lines	R <sub>(DRV)</sub> = 1.5 kΩ to 3.6 V	0.3		
			I <sub>OL</sub> = 12 mA (without R <sub>(DRV)</sub> )	0.5		
V <sub>IT+</sub>	Positive input threshold	TTL/LVCMOS		1.8	V	
		Single-ended	0.8 V ≤ V <sub>ICR</sub> ≤ 2.5 V	1.8		
V <sub>IT-</sub>	Negative-input threshold	TTL/LVCMOS		0.8	V	
		Single-ended	0.8 V ≤ V <sub>ICR</sub> ≤ 2.5 V	1		
V <sub>hys</sub>	Input hysteresis <sup>(1)</sup> (V <sub>T+</sub> - V <sub>T-</sub> )	TTL/LVCMOS		0.3	0.7	mV
		Single-ended	0.8 V ≤ V <sub>ICR</sub> ≤ 2.5 V	300	500	
I <sub>OZ</sub>	High-impedance output current	TTL/LVCMOS	V = V <sub>CC</sub> or GND <sup>(2)</sup>	±10	μA	
		USB data lines	0 V ≤ V <sub>O</sub> ≤ V <sub>CC</sub>	±10		
I <sub>IL</sub>	Low-level input current	TTL/LVCMOS	V <sub>I</sub> = GND	-1	μA	
I <sub>IH</sub>	High-level input current	TTL/LVCMOS	V <sub>I</sub> = V <sub>CC</sub>	1	μA	
Z <sub>0(DRV)</sub>	Driver output impedance	USB data lines	Static V <sub>OH</sub> or V <sub>OL</sub>	7.1	19.9	Ω
V <sub>ID</sub>	Differential input voltage	USB data lines	0.8 V ≤ V <sub>ICR</sub> ≤ 2.5 V	0.2		V
I <sub>CC</sub>	Input supply current		Normal operation	40	mA	
			Suspend mode	1	μA	

(1) Applies for input buffers with hysteresis.

(2) Applies for open drain buffers.

## DIFFERENTIAL DRIVER SWITCHING CHARACTERISTICS Full Speed Mode

over recommended ranges of operating free-air temperature and supply voltage, C<sub>L</sub> = 50 pF (unless otherwise noted)

PARAMETER		TEST CONDITIONS	MIN	MAX	UNIT
t <sub>r</sub>	Transition rise time for DP or DM	See <a href="#">Figure 1</a> and <a href="#">Figure 2</a>	4	20	ns
t <sub>f</sub>	Transition fall time for DP or DM	See <a href="#">Figure 1</a> and <a href="#">Figure 2</a>	4	20	ns
t <sub>(RFM)</sub>	Rise/fall time matching <sup>(1)</sup>	(t <sub>r</sub> /t <sub>f</sub> ) × 100	90	110	%
V <sub>O(CRS)</sub>	Signal crossover output voltage <sup>(1)</sup>		1.3	2.0	V

(1) Characterized only. Limits are approved by design and are not production tested.

## DIFFERENTIAL DRIVER SWITCHING CHARACTERISTICS Low Speed Mode

over recommended ranges of operating free-air temperature and supply voltage, C<sub>L</sub> = 50 pF (unless otherwise noted)

PARAMETER		TEST CONDITIONS	MIN	MAX	UNIT
t <sub>r</sub>	Transition rise time for DP or DM <sup>(1)</sup>	C <sub>L</sub> = 200 pF to 600 pF, See <a href="#">Figure 1</a> and <a href="#">Figure 2</a>	75	300	ns
t <sub>f</sub>	Transition fall time for DP or DM <sup>(1)</sup>	C <sub>L</sub> = 200 pF to 600 pF, See <a href="#">Figure 1</a> and <a href="#">Figure 2</a>	75	300	ns
t <sub>(RFM)</sub>	Rise/fall time matching <sup>(1)</sup>	(t <sub>r</sub> /t <sub>f</sub> ) × 100	80	120	%
V <sub>O(CRS)</sub>	Signal crossover output voltage <sup>(1)</sup>	C <sub>L</sub> = 200 pF to 600 pF	1.3	2.0	V

(1) Characterized only. Limits are approved by design and are not production tested.

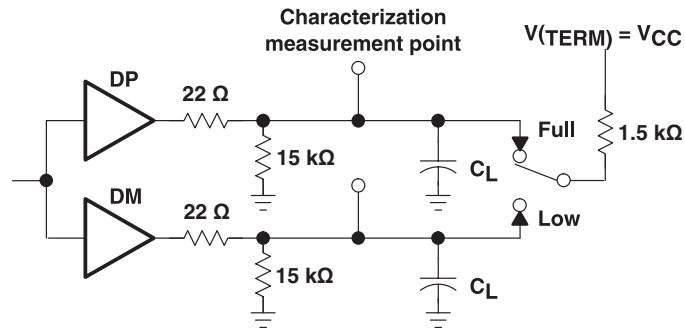
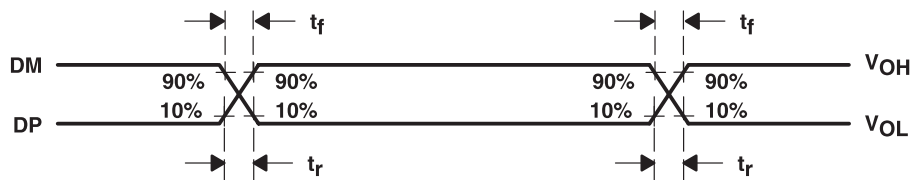

Figure 1. Differential Driver Switching Load



NOTE: The  $t_r/t_f$  ratio is measured as  $t_r(DP)/t_f(DM)$  and  $t_r(DM)/t_f(DP)$  at each crossover point.

Figure 2. Differential Driver Timing Waveforms

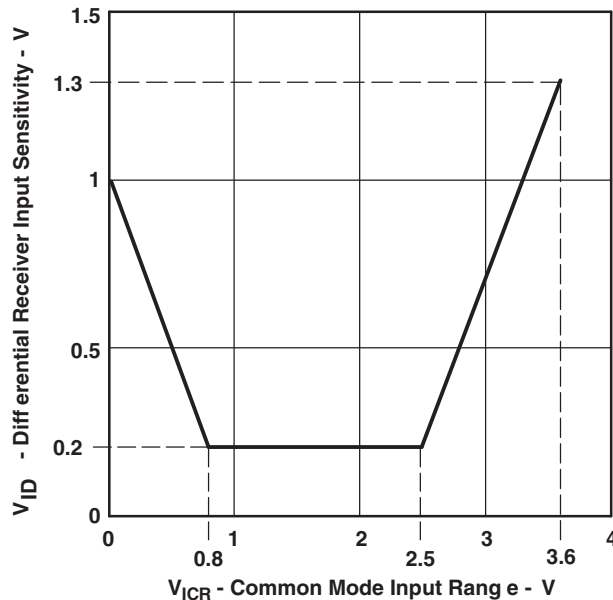

Figure 3. Differential Receiver Input Sensitivity vs Common Mode Input Range

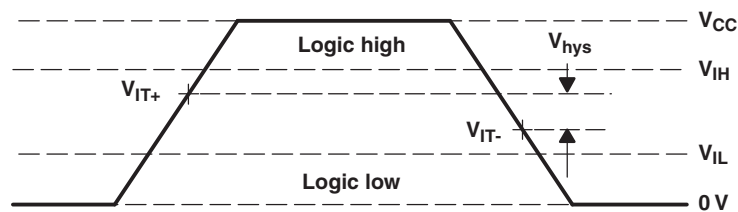
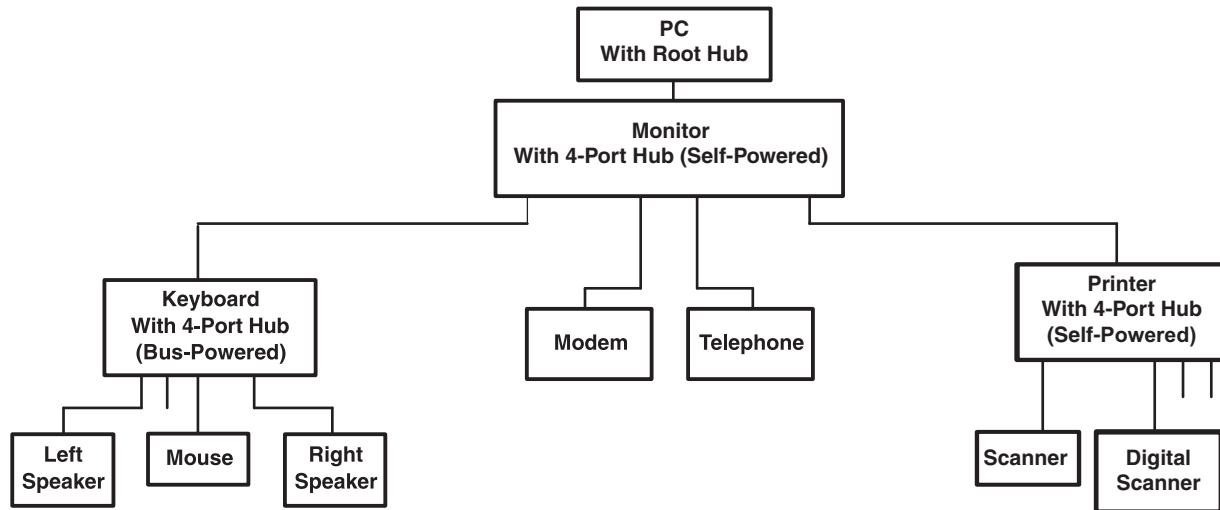

Figure 4. Single-Ended Receiver Input Signal Parameter Definitions



## APPLICATION INFORMATION

A major advantage of USB is the ability to connect 127 functions configured in up to 6 logical layers (tiers) to a single personal computer (see [Figure 5](#)).



**Figure 5. USB-Tiered Configuration Example**

Another advantage of USB is that all peripherals are connected using a standardized four-wire cable that provides both communication and power distribution. The power configurations are bus-powered and self-powered modes. The maximum current that may be drawn from the USB 5-V line during power up is 100 mA. For the bus-powered mode, a hub can draw a maximum of 500 mA from the 5-V line of the USB cable. A bus-powered hub must always be connected downstream to a self-powered hub unless it is the only hub connected to the PC and there are no high-powered functions connected downstream. In the self-powered mode, the hub is connected to an external power supply and can supply up to 500 mA to each downstream port. High-powered functions may draw a maximum of 500 mA from each downstream port and may only be connected downstream to self-powered hubs. Per the USB specification, in the bus-powered mode, each downstream port can provide a maximum of 100 mA of current, and in the self-powered mode, each downstream port can provide a maximum of 500 mA of current.

Both bus-powered and self-powered hubs require overcurrent protection for all downstream ports. The two types of protection are individual-port management (individual-port basis) or ganged-port management (multiple-port basis). Individual-port management requires power-management devices for each individual downstream port, but adds robustness to the USB system because, in the event of an overcurrent condition, the USB host only powers down the port that has the condition. The ganged configuration uses fewer power management devices and thus has lower system costs, but in the event of an overcurrent condition on any of the downstream ports, all the ganged ports are disabled by the USB host.

Using a combination of the BUSPWR and EEDATA/GANGED inputs, the TUSB2046B supports four modes of power management: bus-powered hub with either individual-port power management or ganged-port power management, and the self-powered hub with either individual-port power management or ganged-port power management. Texas Instruments supplies the complete hub solution with the TUSB2036 (2/3-port), TUSB2046B, and the TUSB2077 (7-port) hubs along with the power-management devices needed to implement a fully USB specification-compliant system.

## USB Design Notes

The following sections provide block diagram examples of how to implement the TUSB2046B device. Note, even though no resistors are shown, pullup, pulldown, and series resistors must be used to properly implement this device.

Figure 6 is an example of how to generate the 6-MHz clock signal.

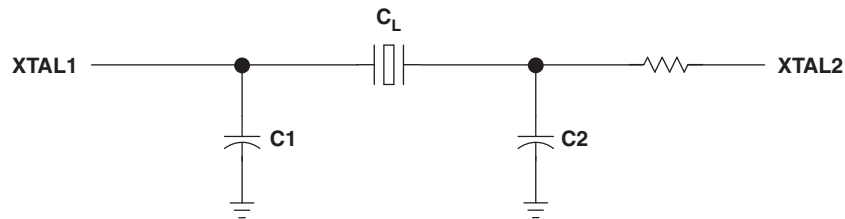

NOTE: This figure assumes a 6-MHz fundamental crystal that is parallel loaded. The component values of C1, C2, and  $R_d$  are determined using a crystal from Fox Electronics – part number HC49U-6.00MHz 30\50\0-70\20, which means  $\pm 30$  ppm at 25°C and  $\pm 50$  ppm from 0°C to 70°C. The characteristics for the crystal include a load capacitance ( $C_L$ ) of 20 pF, maximum shunt capacitance ( $C_0$ ) of 7 pF, and the maximum ESR of 50  $\Omega$ . In order to insure enough negative resistance, use  $C1 = C2 = 27$  pF. The resistor  $R_d$  is used to trim the gain, and  $R_d = 1.5$  k $\Omega$  is recommended.

Figure 6. Crystal Tuning Circuit

## Input Clock Configuration

The input clock configuration logic of TUSB2046B is enhanced to accept a 6-MHz crystal or 48-MHz on-the-board clock source with a simple tie-off change on TSTMODE (terminal 31).

- A 6-MHz input clock configuration is shown in Figure 7. In this mode, both TSTMODE and TSTPLL/48MCLK terminals must be tied to ground. The hub is configured to use the 6-MHz clock on terminals 30 and 29, which are XTAL1 and XTAL2, respectively, on the TUSB2046B. This is identical to the TUSB2046.

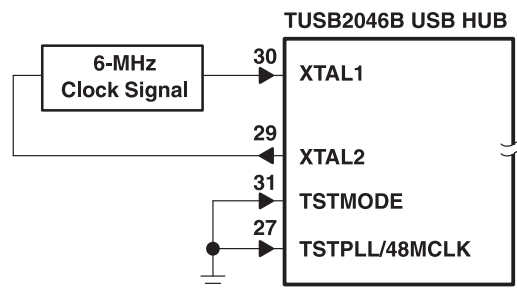

Figure 7. 6-MHz Input Clock Configuration

- A 48-MHz input clock configuration is shown in Figure 8. In this mode, both TSTMODE and XTAL1 terminals must be tied to 3.3-V  $V_{CC}$ . The hub accepts the 48-MHz clock input on TSTPLL/48MCLK (terminal 27). XTAL2 must be left floating (open) for this configuration. Only the oscillator or the onboard clock source is accepted for this mode. A crystal can not be used for this mode, since the chip's internal oscillator cell only supports the fundamental frequency.

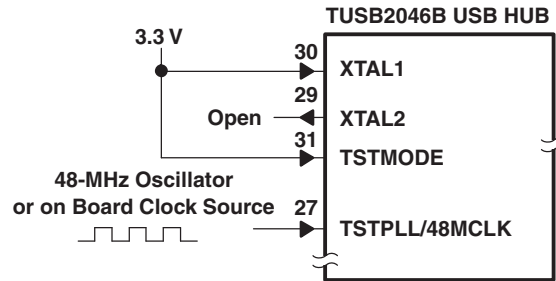

Figure 8. 48-MHz Input Clock Configuration

Figure 9 is a block diagram example of how to connect the external EEPROM if a custom product ID and vendor ID are desired. Figure 10 shows the EEPROM read operation timing diagram. Figure 11, Figure 12, and Figure 13 illustrate how to connect the TUSB2046B device for different power source and port power-management combinations.

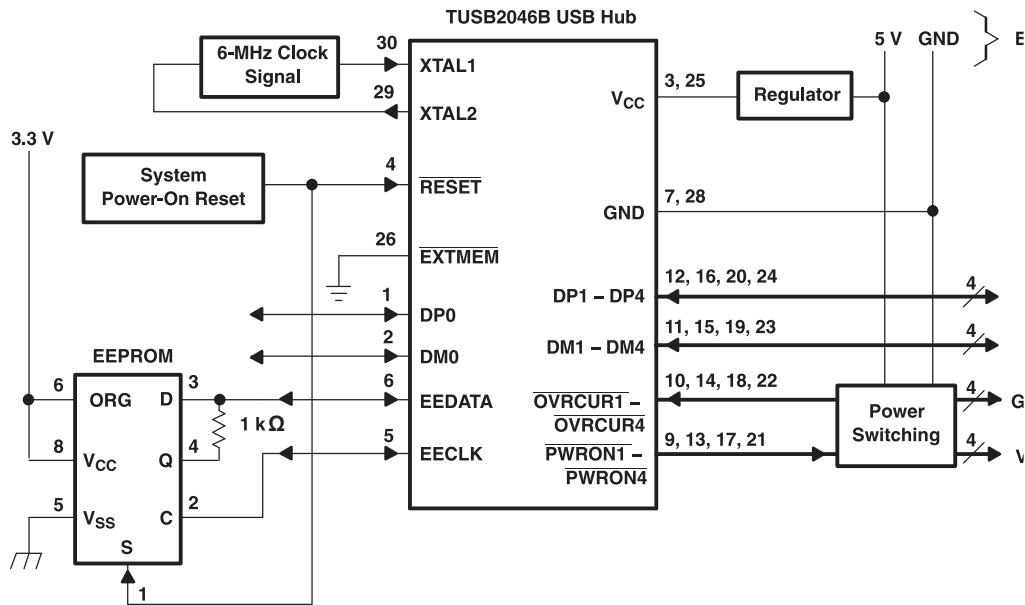

Figure 9. Typical Application of the TUSB2046B USB Hub

## Programming the EEPROM

An SGS Thompson M93C46 EEPROM, or equivalent, stores the programmable VID and PID. When the EEPROM interface is enabled ( $\overline{\text{EXTMEM}} = 0$ ), the EECLK and EEDATA are internally pulled down (100  $\mu\text{A}$ ) inside the TUSB2046B. The internal pulldowns are disabled when the EEPROM interface is disabled ( $\overline{\text{EXTMEM}} = 1$ ).

The EEPROM is programmed with the three 16-bit locations as shown in Table 1. Connecting terminal 6 of the EEPROM high (ORG = 1) organizes the EEPROM memory into 64 $\times$ 16-bit words.

**Table 1. EEPROM Memory Map**

ADDRESS	D15	D14	D13	D12–D8	D7–D0
00000	0	GANGED	00000	00000	00000000
00001	VID High-byte				VID Low-byte
00010	PID High-byte				PID Low-byte
XXXXXXXX					

The D and Q signals of the EEPROM must be tied together using a 1-k $\Omega$  resistor with the common I/O operations forming a single-wire bus. After system power-on reset, the TUSB2046B performs a one-time access read operation from the EEPROM if the  $\overline{\text{EXTMEM}}$  terminal is pulled low and the chip select(s) of the EEPROM is connected to the system power-on reset. Initially, the EEDATA terminal is driven by the TUSB2046B to send a start bit (1) which is followed by the read instruction (10) and the starting-word address (00000). Once the read instruction is received, the instruction and address are decoded by the EEPROM, which then sends the data to the output shift register. At this point, the hub stops driving the EEDATA terminal and the EEPROM starts driving. A dummy (0) bit is then output and the first three 16-bit words in the EEPROM are output with the most significant bit (MSB) first.

The output data changes are triggered by the rising edge of the clock provided by the TUSB2046B on the EECLK terminal. The SGS-Thompson M936C46 EEPROM is recommended because it advances to the next memory location by automatically incrementing the address internally. Any EEPROM used must have the automatic internal address advance function. After reading the three words of data from the EEPROM, the TUSB2046B puts the EEPROM interface into a high-impedance condition (pulled down internally) to allow other logic to share the EEPROM. The EEPROM read operation is summarized in Figure 10. For more details on EEPROM operation, refer to *SGS-Thompson Microelectronics M93C46 Serial Microwire Bus EEPROM* data sheet.

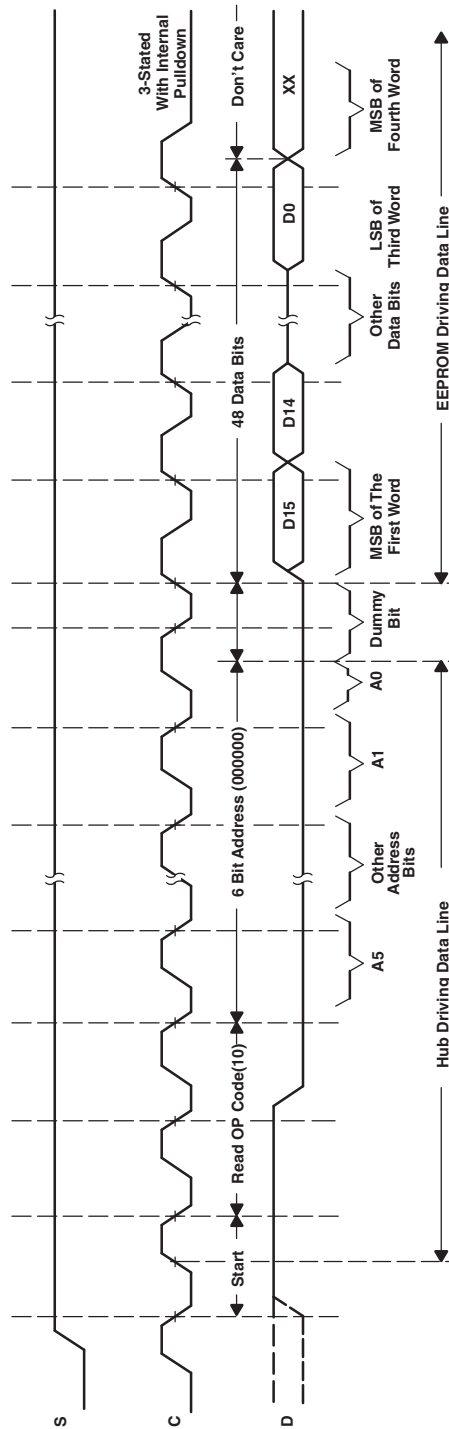
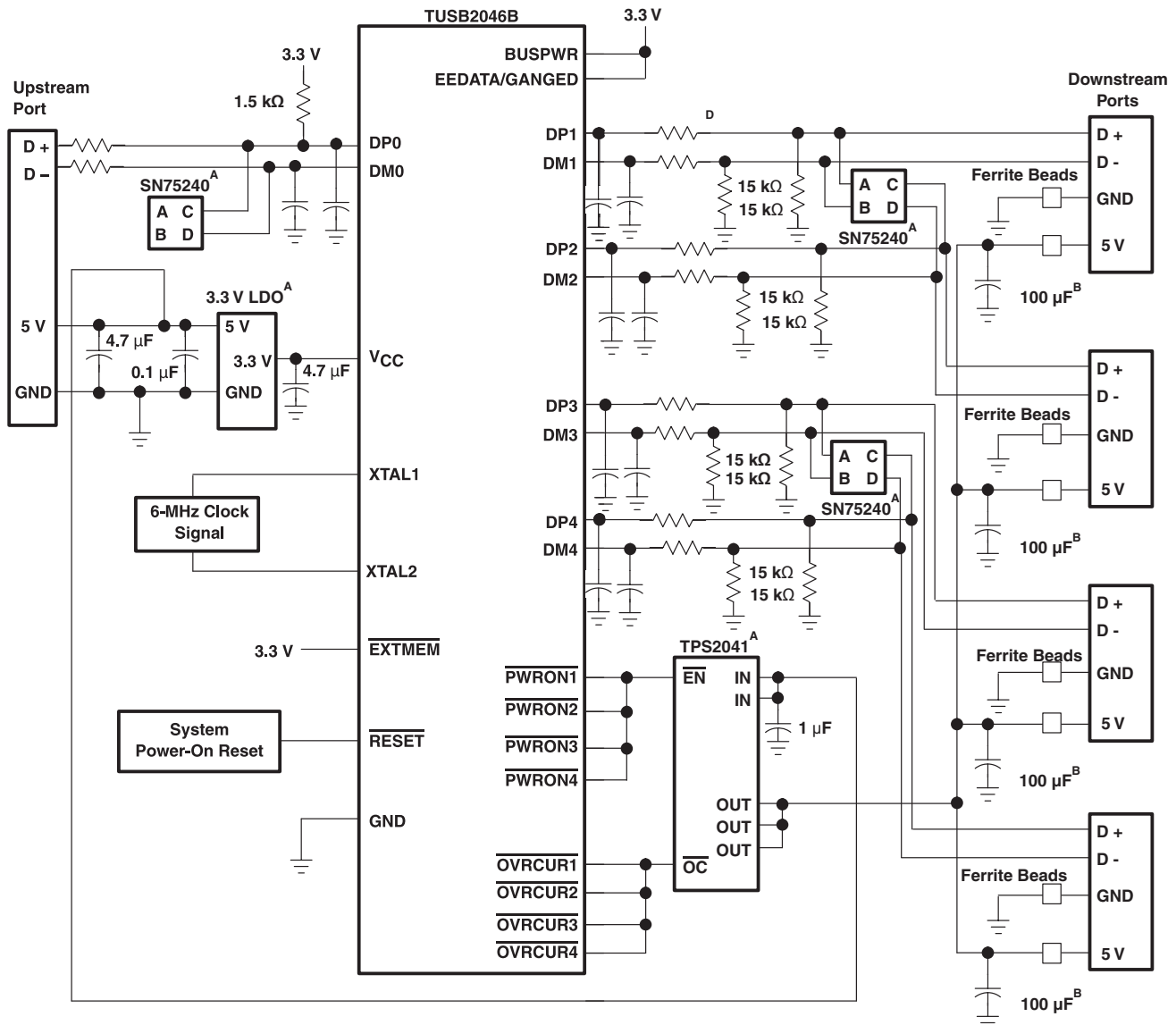

Figure 10. EEPROM Read Operation Timing Diagram

## Bus-Powered Hub, Ganged-Port Power Management

When used in bus-powered mode, the TUSB2046B supports up to four downstream ports by controlling a TPS2041 device which is capable of supplying 100 mA of current to each downstream port. Bus-powered hubs must implement power switching to ensure current demand is held below 100 mA when the hub is hot-plugged into the system. Utilizing the TPS2041 for ganged-port power management provides overcurrent protection for the downstream ports. The SN75240 transient suppressors reduce inrush current and voltage spikes on the data lines. The  $\overline{\text{OVR}}\text{CUR}$  signals must be tied together for a ganged operation.



- NOTES: A. TPS2041 and SN75240 are Texas Instruments devices. The  $\overline{\text{OC}}\text{n}$  outputs of the TPS204n are open drain. A 10-k $\Omega$  pullup is recommended.
- B. 120  $\mu\text{F}$  per hub is the minimum required per the USB specification. However, TI recommends a 100- $\mu\text{F}$ , low ESR, tantalum capacitor per port for immunity to voltage droop.
- C. LDO is a 5-V-to-3.3-V voltage regulator
- D. All USB DP, DM signal pairs require series resistors of approximately 27 $\Omega$  to ensure proper termination. An optional filter capacitor of about 22 pF is recommended for EMI suppression. This capacitor, if used, must be placed between the hub terminal and the series resistor, as per section 7.1.6 of the USB specification.

Figure 11. TUSB2046B Bus-Powered Hub, Ganged-Port Power-Management Application

## Self-Powered Hub, Ganged-Port Power Management

The TUSB2046B can also be implemented for ganged-port power management in a self-powered configuration. The implementation is very similar to the bus-powered example with the exception that a self-powered port supplies 500 mA of current to each downstream port. The overcurrent protection can be provided by a TPS2044 quad device or a TPS2024 single power switch.

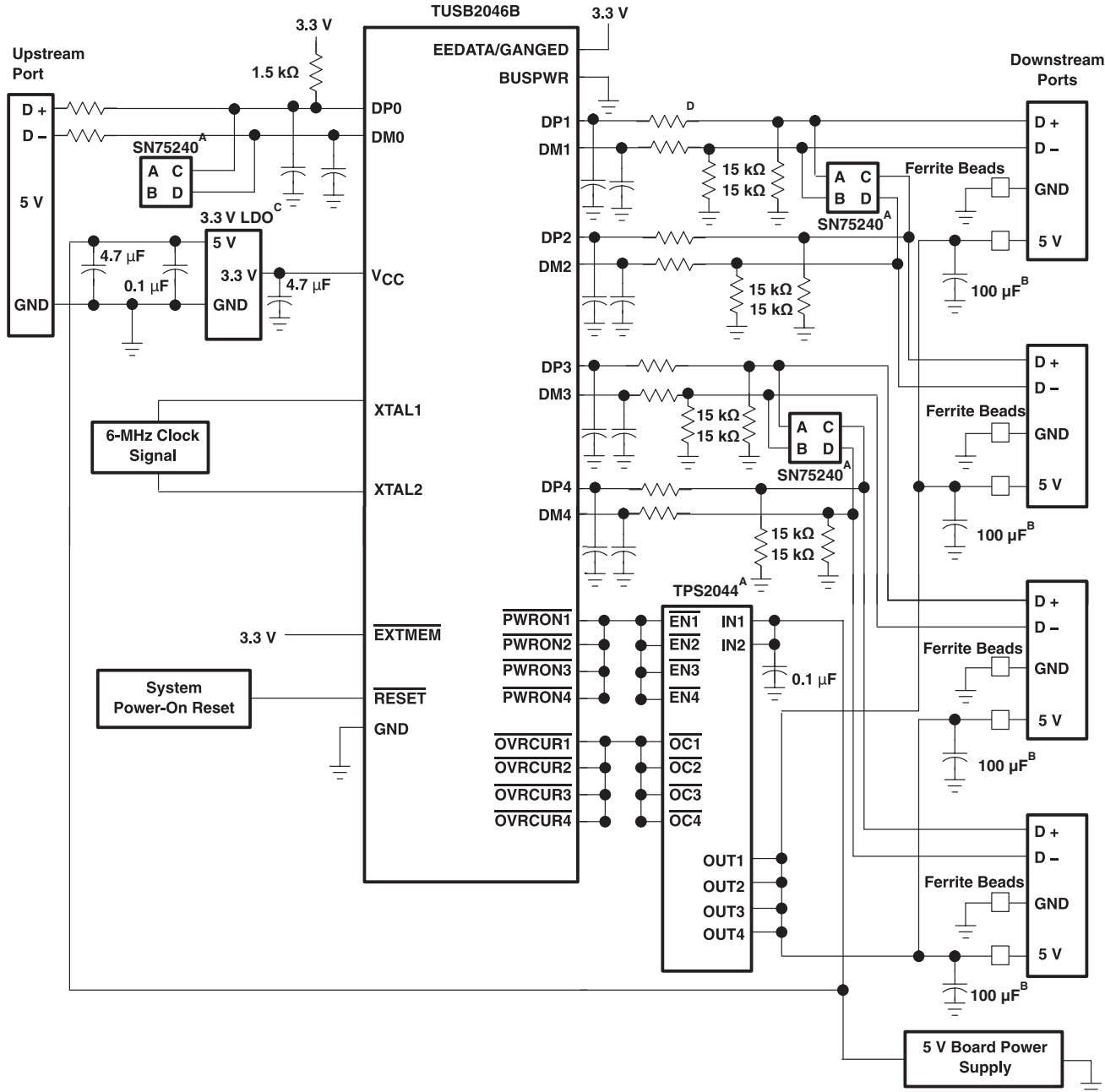

- NOTES: A. TPS2044, TPS2042, and SN75240 are Texas Instruments devices. The TPS2042 can be substituted for the TPS2044. The OC<sub>n</sub> outputs of the TPS204n are open drain. A 10-kΩ pullup is recommended.
- B. 120 μF per hub is the minimum required per the USB specification. However, TI recommends a 100-μF, low ESR, tantalum capacitor per port for immunity to voltage droop.
- C. LDO is a 5-V-to-3.3-V voltage regulator
- D. All USB DP, DM signal pairs require series resistors of approximately 27Ω to ensure proper termination. An optional filter capacitor of about 22 pF is recommended for EMI suppression. This capacitor, if used, must be placed between the hub terminal and the series resistor, as per section 7.1.6 of the USB specification.

Figure 12. TUSB2046B Self-Powered Hub, Ganged-Port Power-Management Application

## Self-Powered Hub, Individual-Port Power Management

In a self-powered configuration, the TUSB2046B can be implemented for individual-port power management when used with the TPS2044, because it is capable of supplying 500 mA of current to each downstream port and can provide current limiting on a per-port basis. When the hub detects a fault on a downstream port, power is removed from only the port with the fault and the remaining ports continue to operate normally. Self-powered hubs are required to implement overcurrent protection and report overcurrent conditions. The SN75240 transient suppressors reduce inrush current and voltage spikes on the data lines.

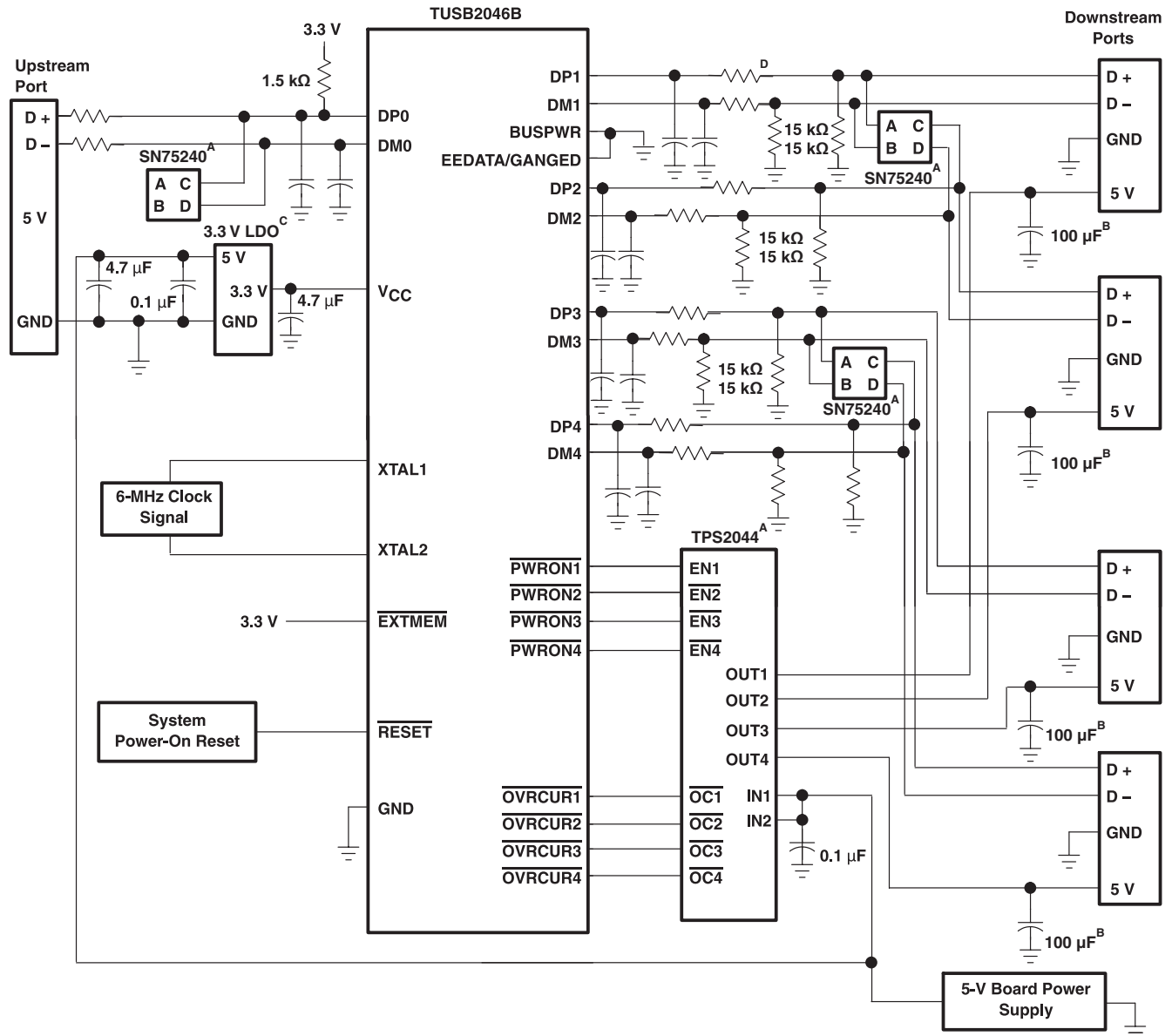

- NOTES: A. TPS2044, TPS2042, and SN75240 are Texas Instruments devices. Two TPS2042 devices can be substituted for the TPS2044. The  $\overline{OCn}$  outputs of the TPS204n are open drain. A 10-kΩ pullup is recommended.
- B. 120 μF per hub is the minimum required per the USB specification. However, TI recommends a 100-μF, low ESR, tantalum capacitor per port for immunity to voltage droop.
- C. LDO is a 5-V-to-3.3-V voltage regulator
- D. All USB DP, DM signal pairs require series resistors of approximately 27Ω to ensure proper termination. An optional filter capacitor of about 22 pF is recommended for EMI suppression. This capacitor, if used, must be placed between the hub terminal and the series resistor, as per section 7.1.6 of the USB specification.

Figure 13. TUSB2046B Self-Powered Hub, Individual-Port Power-Management Application



**PACKAGING INFORMATION**

Orderable Device	Status (1)	Package Type	Package Drawing	Pins	Package Qty	Eco Plan (2)	Lead/Ball Finish	MSL Peak Temp (3)	Op Temp (°C)	Device Marking (4/5)	Samples
TUSB2046BIRHBR	ACTIVE	VQFN	RHB	32	3000	Green (RoHS & no Sb/Br)	CU NIPDAU	Level-2-260C-1 YEAR	-40 to 85	TUSB 2046BI	<a href="#">Samples</a>
TUSB2046BIRHBRG4	ACTIVE	VQFN	RHB	32	3000	Green (RoHS & no Sb/Br)	CU NIPDAU	Level-2-260C-1 YEAR	-40 to 85	TUSB 2046BI	<a href="#">Samples</a>
TUSB2046BIRHBT	ACTIVE	VQFN	RHB	32	250	Green (RoHS & no Sb/Br)	CU NIPDAU	Level-2-260C-1 YEAR	-40 to 85	TUSB 2046BI	<a href="#">Samples</a>
TUSB2046BIRHBTG4	ACTIVE	VQFN	RHB	32	250	Green (RoHS & no Sb/Br)	CU NIPDAU	Level-2-260C-1 YEAR	-40 to 85	TUSB 2046BI	<a href="#">Samples</a>
TUSB2046BIVFR	ACTIVE	LQFP	VF	32	1000	Green (RoHS & no Sb/Br)	CU NIPDAU	Level-3-260C-168 HR	-40 to 85	USB2046BI	<a href="#">Samples</a>
TUSB2046BIVFRG4	ACTIVE	LQFP	VF	32	1000	Green (RoHS & no Sb/Br)	CU NIPDAU	Level-3-260C-168 HR	-40 to 85	USB2046BI	<a href="#">Samples</a>
TUSB2046BVF	ACTIVE	LQFP	VF	32	250	Green (RoHS & no Sb/Br)	CU NIPDAU	Level-3-260C-168 HR	0 to 70	TUSB2046B	<a href="#">Samples</a>
TUSB2046BVFG4	ACTIVE	LQFP	VF	32	250	Green (RoHS & no Sb/Br)	CU NIPDAU	Level-3-260C-168 HR	0 to 70	TUSB2046B	<a href="#">Samples</a>
TUSB2046BVFR	ACTIVE	LQFP	VF	32	1000	Green (RoHS & no Sb/Br)	CU NIPDAU	Level-3-260C-168 HR	0 to 70	TUSB2046B	<a href="#">Samples</a>
TUSB2046BVFRG4	ACTIVE	LQFP	VF	32	1000	Green (RoHS & no Sb/Br)	CU NIPDAU	Level-3-260C-168 HR	0 to 70	TUSB2046B	<a href="#">Samples</a>

(1) The marketing status values are defined as follows:

**ACTIVE:** Product device recommended for new designs.

**LIFEBUY:** TI has announced that the device will be discontinued, and a lifetime-buy period is in effect.

**NRND:** Not recommended for new designs. Device is in production to support existing customers, but TI does not recommend using this part in a new design.

**PREVIEW:** Device has been announced but is not in production. Samples may or may not be available.

**OBSOLETE:** TI has discontinued the production of the device.

(2) Eco Plan - The planned eco-friendly classification: Pb-Free (RoHS), Pb-Free (RoHS Exempt), or Green (RoHS & no Sb/Br) - please check <http://www.ti.com/productcontent> for the latest availability information and additional product content details.

**TBD:** The Pb-Free/Green conversion plan has not been defined.

**Pb-Free (RoHS):** TI's terms "Lead-Free" or "Pb-Free" mean semiconductor products that are compatible with the current RoHS requirements for all 6 substances, including the requirement that lead not exceed 0.1% by weight in homogeneous materials. Where designed to be soldered at high temperatures, TI Pb-Free products are suitable for use in specified lead-free processes.

**Pb-Free (RoHS Exempt):** This component has a RoHS exemption for either 1) lead-based flip-chip solder bumps used between the die and package, or 2) lead-based die adhesive used between the die and leadframe. The component is otherwise considered Pb-Free (RoHS compatible) as defined above.

**Green (RoHS & no Sb/Br):** TI defines "Green" to mean Pb-Free (RoHS compatible), and free of Bromine (Br) and Antimony (Sb) based flame retardants (Br or Sb do not exceed 0.1% by weight in homogeneous material)

(3) MSL, Peak Temp. -- The Moisture Sensitivity Level rating according to the JEDEC industry standard classifications, and peak solder temperature.

(4) There may be additional marking, which relates to the logo, the lot trace code information, or the environmental category on the device.

(5) Multiple Device Markings will be inside parentheses. Only one Device Marking contained in parentheses and separated by a "~" will appear on a device. If a line is indented then it is a continuation of the previous line and the two combined represent the entire Device Marking for that device.

**Important Information and Disclaimer:**The information provided on this page represents TI's knowledge and belief as of the date that it is provided. TI bases its knowledge and belief on information provided by third parties, and makes no representation or warranty as to the accuracy of such information. Efforts are underway to better integrate information from third parties. TI has taken and continues to take reasonable steps to provide representative and accurate information but may not have conducted destructive testing or chemical analysis on incoming materials and chemicals. TI and TI suppliers consider certain information to be proprietary, and thus CAS numbers and other limited information may not be available for release.

In no event shall TI's liability arising out of such information exceed the total purchase price of the TI part(s) at issue in this document sold by TI to Customer on an annual basis.

**OTHER QUALIFIED VERSIONS OF TUSB2046B :**

- Automotive: [TUSB2046B-Q1](#)

**NOTE: Qualified Version Definitions:**

- Automotive - Q100 devices qualified for high-reliability automotive applications targeting zero defects

**TAPE AND REEL INFORMATION**

**QUADRANT ASSIGNMENTS FOR PIN 1 ORIENTATION IN TAPE**

\*All dimensions are nominal

Device	Package Type	Package Drawing	Pins	SPQ	Reel Diameter (mm)	Reel Width W1 (mm)	A0 (mm)	B0 (mm)	K0 (mm)	P1 (mm)	W (mm)	Pin1 Quadrant
TUSB2046BIRHBR	VQFN	RHB	32	3000	330.0	12.4	5.3	5.3	1.5	8.0	12.0	Q2
TUSB2046BIRHBT	VQFN	RHB	32	250	180.0	12.4	5.3	5.3	1.5	8.0	12.0	Q2
TUSB2046BIVFR	LQFP	VF	32	1000	330.0	16.4	9.6	9.6	1.9	12.0	16.0	Q2
TUSB2046BVFR	LQFP	VF	32	1000	330.0	16.4	9.6	9.6	1.9	12.0	16.0	Q2

**TAPE AND REEL BOX DIMENSIONS**



\*All dimensions are nominal

Device	Package Type	Package Drawing	Pins	SPQ	Length (mm)	Width (mm)	Height (mm)
TUSB2046BIRHBR	VQFN	RHB	32	3000	338.1	338.1	20.6
TUSB2046BIRHBT	VQFN	RHB	32	250	210.0	185.0	35.0
TUSB2046BIVFR	LQFP	VF	32	1000	367.0	367.0	38.0
TUSB2046BVFR	LQFP	VF	32	1000	336.6	336.6	31.8

# MECHANICAL DATA

RHB (S-PVQFN-N32)

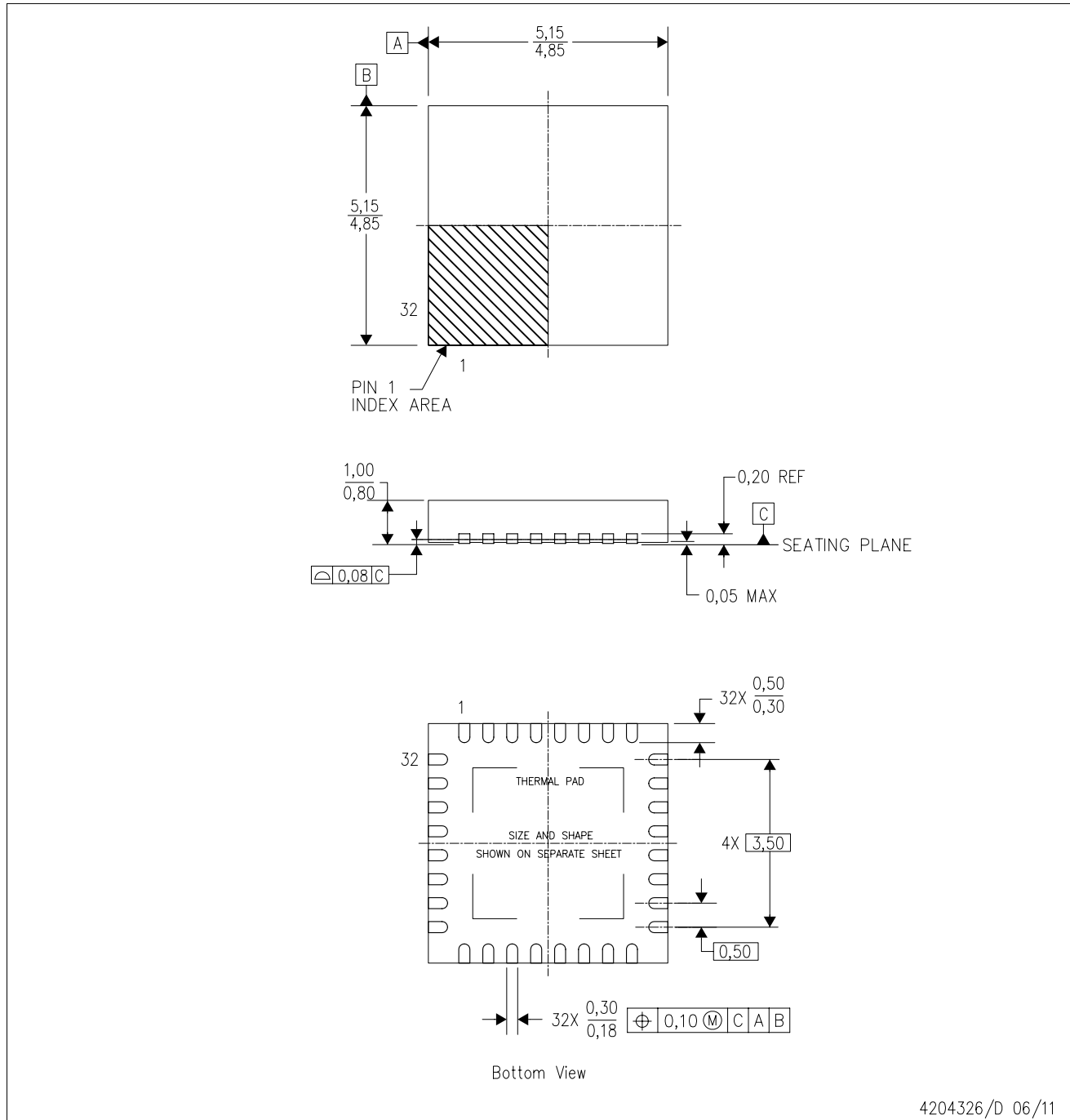
PLASTIC QUAD FLATPACK NO-LEAD



- NOTES:
- All linear dimensions are in millimeters. Dimensioning and tolerancing per ASME Y14.5M-1994.
  - This drawing is subject to change without notice.
  - QFN (Quad Flatpack No-Lead) Package configuration.
  - The package thermal pad must be soldered to the board for thermal and mechanical performance.
  - See the additional figure in the Product Data Sheet for details regarding the exposed thermal pad features and dimensions.
  - Falls within JEDEC MO-220.

THERMAL INFORMATION

This package incorporates an exposed thermal pad that is designed to be attached directly to an external heatsink. The thermal pad must be soldered directly to the printed circuit board (PCB). After soldering, the PCB can be used as a heatsink. In addition, through the use of thermal vias, the thermal pad can be attached directly to the appropriate copper plane shown in the electrical schematic for the device, or alternatively, can be attached to a special heatsink structure designed into the PCB. This design optimizes the heat transfer from the integrated circuit (IC).

For information on the Quad Flatpack No-Lead (QFN) package and its advantages, refer to Application Report, QFN/SON PCB Attachment, Texas Instruments Literature No. SLUA271. This document is available at [www.ti.com](http://www.ti.com).

The exposed thermal pad dimensions for this package are shown in the following illustration.

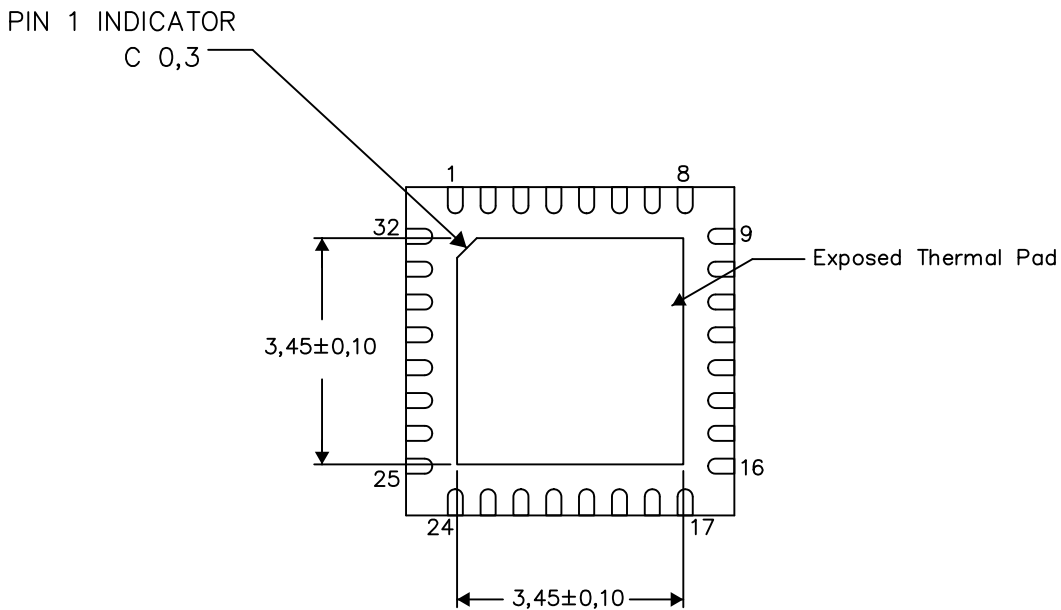

Bottom View

Exposed Thermal Pad Dimensions

4206356-2/Y 06/13

NOTE: A. All linear dimensions are in millimeters

RHB (S-PVQFN-N32)

PLASTIC QUAD FLATPACK NO-LEAD

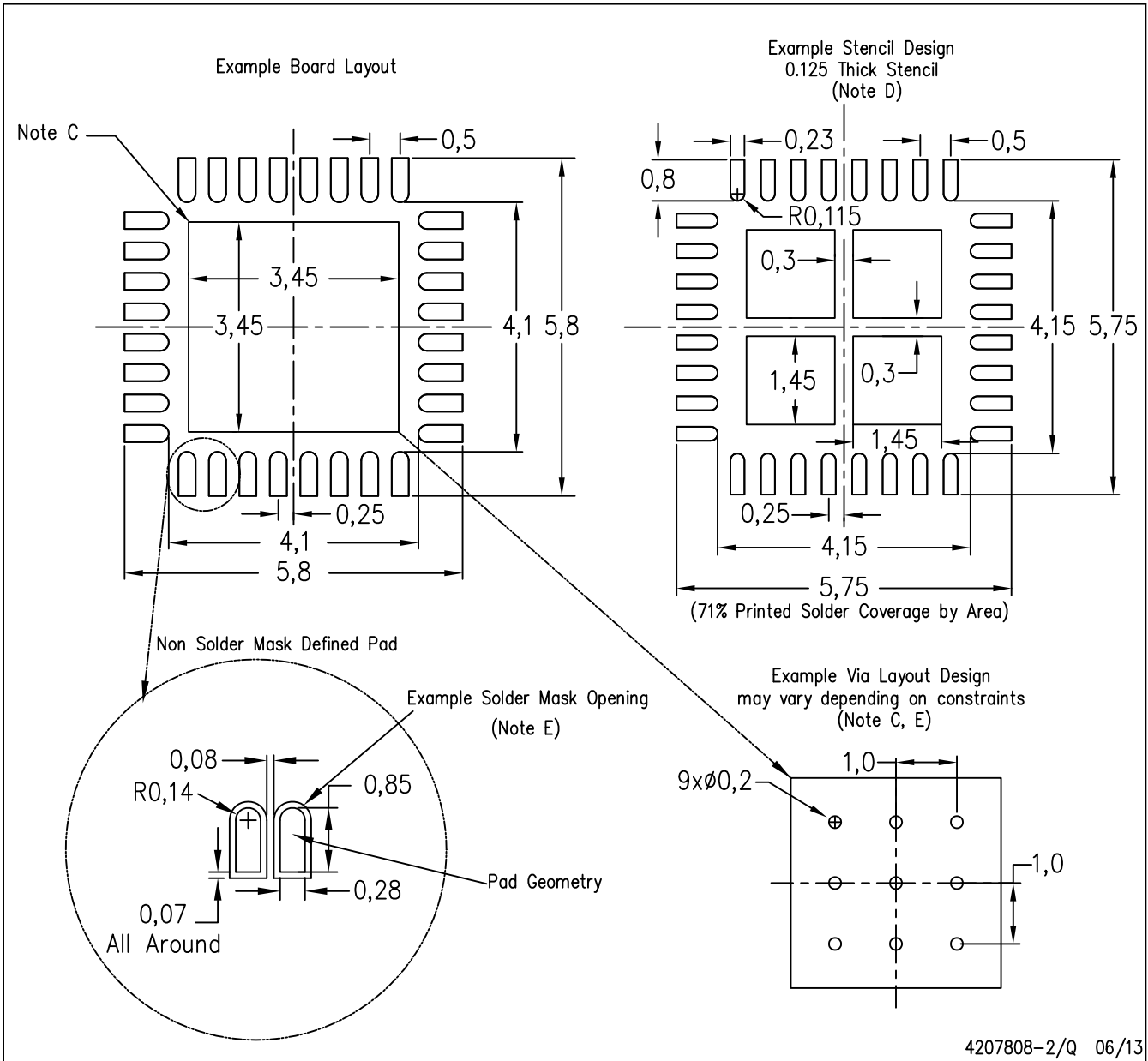

- NOTES:
- A. All linear dimensions are in millimeters.
  - B. This drawing is subject to change without notice.
  - C. This package is designed to be soldered to a thermal pad on the board. Refer to Application Note, Quad Flat-Pack Packages, Texas Instruments Literature No. SLUA271, and also the Product Data Sheets for specific thermal information, via requirements, and recommended board layout. These documents are available at [www.ti.com](http://www.ti.com) <<http://www.ti.com>>.
  - D. Laser cutting apertures with trapezoidal walls and also rounding corners will offer better paste release. Customers should contact their board assembly site for stencil design recommendations. Refer to IPC 7525 for stencil design considerations.
  - E. Customers should contact their board fabrication site for recommended solder mask tolerances and via tenting recommendations for vias placed in the thermal pad.

VF (S-PQFP-G32)

PLASTIC QUAD FLATPACK

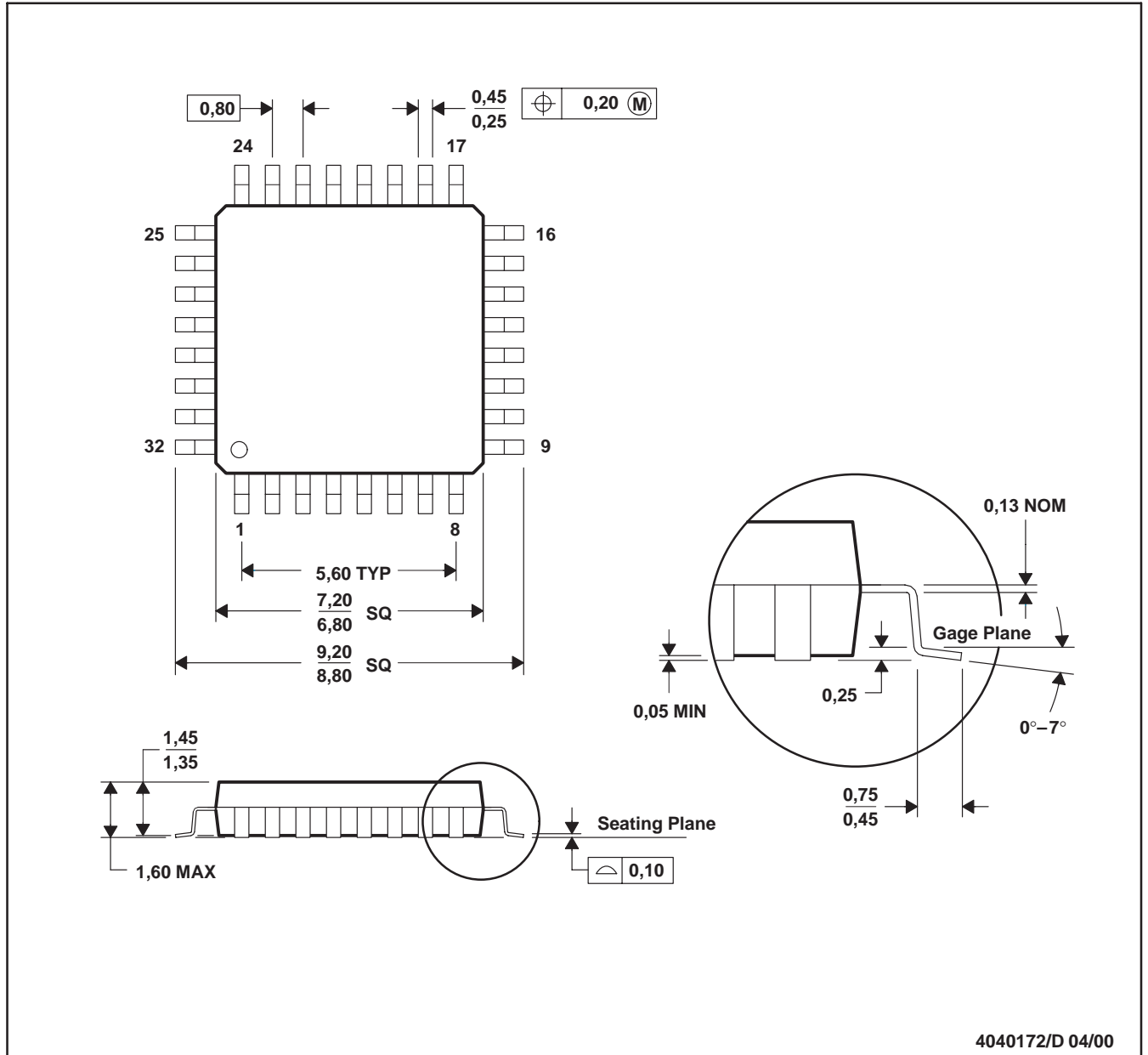

NOTES: A. All linear dimensions are in millimeters.  
 B. This drawing is subject to change without notice.



## IMPORTANT NOTICE

Texas Instruments Incorporated and its subsidiaries (TI) reserve the right to make corrections, enhancements, improvements and other changes to its semiconductor products and services per JESD46, latest issue, and to discontinue any product or service per JESD48, latest issue. Buyers should obtain the latest relevant information before placing orders and should verify that such information is current and complete. All semiconductor products (also referred to herein as "components") are sold subject to TI's terms and conditions of sale supplied at the time of order acknowledgment.

TI warrants performance of its components to the specifications applicable at the time of sale, in accordance with the warranty in TI's terms and conditions of sale of semiconductor products. Testing and other quality control techniques are used to the extent TI deems necessary to support this warranty. Except where mandated by applicable law, testing of all parameters of each component is not necessarily performed.

TI assumes no liability for applications assistance or the design of Buyers' products. Buyers are responsible for their products and applications using TI components. To minimize the risks associated with Buyers' products and applications, Buyers should provide adequate design and operating safeguards.

TI does not warrant or represent that any license, either express or implied, is granted under any patent right, copyright, mask work right, or other intellectual property right relating to any combination, machine, or process in which TI components or services are used. Information published by TI regarding third-party products or services does not constitute a license to use such products or services or a warranty or endorsement thereof. Use of such information may require a license from a third party under the patents or other intellectual property of the third party, or a license from TI under the patents or other intellectual property of TI.

Reproduction of significant portions of TI information in TI data books or data sheets is permissible only if reproduction is without alteration and is accompanied by all associated warranties, conditions, limitations, and notices. TI is not responsible or liable for such altered documentation. Information of third parties may be subject to additional restrictions.

Resale of TI components or services with statements different from or beyond the parameters stated by TI for that component or service voids all express and any implied warranties for the associated TI component or service and is an unfair and deceptive business practice. TI is not responsible or liable for any such statements.

Buyer acknowledges and agrees that it is solely responsible for compliance with all legal, regulatory and safety-related requirements concerning its products, and any use of TI components in its applications, notwithstanding any applications-related information or support that may be provided by TI. Buyer represents and agrees that it has all the necessary expertise to create and implement safeguards which anticipate dangerous consequences of failures, monitor failures and their consequences, lessen the likelihood of failures that might cause harm and take appropriate remedial actions. Buyer will fully indemnify TI and its representatives against any damages arising out of the use of any TI components in safety-critical applications.

In some cases, TI components may be promoted specifically to facilitate safety-related applications. With such components, TI's goal is to help enable customers to design and create their own end-product solutions that meet applicable functional safety standards and requirements. Nonetheless, such components are subject to these terms.

No TI components are authorized for use in FDA Class III (or similar life-critical medical equipment) unless authorized officers of the parties have executed a special agreement specifically governing such use.

Only those TI components which TI has specifically designated as military grade or "enhanced plastic" are designed and intended for use in military/aerospace applications or environments. Buyer acknowledges and agrees that any military or aerospace use of TI components which have **not** been so designated is solely at the Buyer's risk, and that Buyer is solely responsible for compliance with all legal and regulatory requirements in connection with such use.

TI has specifically designated certain components as meeting ISO/TS16949 requirements, mainly for automotive use. In any case of use of non-designated products, TI will not be responsible for any failure to meet ISO/TS16949.

### Products

Audio	<a href="http://www.ti.com/audio">www.ti.com/audio</a>
Amplifiers	<a href="http://amplifier.ti.com">amplifier.ti.com</a>
Data Converters	<a href="http://dataconverter.ti.com">dataconverter.ti.com</a>
DLP® Products	<a href="http://www.dlp.com">www.dlp.com</a>
DSP	<a href="http://dsp.ti.com">dsp.ti.com</a>
Clocks and Timers	<a href="http://www.ti.com/clocks">www.ti.com/clocks</a>
Interface	<a href="http://interface.ti.com">interface.ti.com</a>
Logic	<a href="http://logic.ti.com">logic.ti.com</a>
Power Mgmt	<a href="http://power.ti.com">power.ti.com</a>
Microcontrollers	<a href="http://microcontroller.ti.com">microcontroller.ti.com</a>
RFID	<a href="http://www.ti-rfid.com">www.ti-rfid.com</a>
OMAP Applications Processors	<a href="http://www.ti.com/omap">www.ti.com/omap</a>
Wireless Connectivity	<a href="http://www.ti.com/wirelessconnectivity">www.ti.com/wirelessconnectivity</a>

### Applications

Automotive and Transportation	<a href="http://www.ti.com/automotive">www.ti.com/automotive</a>
Communications and Telecom	<a href="http://www.ti.com/communications">www.ti.com/communications</a>
Computers and Peripherals	<a href="http://www.ti.com/computers">www.ti.com/computers</a>
Consumer Electronics	<a href="http://www.ti.com/consumer-apps">www.ti.com/consumer-apps</a>
Energy and Lighting	<a href="http://www.ti.com/energy">www.ti.com/energy</a>
Industrial	<a href="http://www.ti.com/industrial">www.ti.com/industrial</a>
Medical	<a href="http://www.ti.com/medical">www.ti.com/medical</a>
Security	<a href="http://www.ti.com/security">www.ti.com/security</a>
Space, Avionics and Defense	<a href="http://www.ti.com/space-avionics-defense">www.ti.com/space-avionics-defense</a>
Video and Imaging	<a href="http://www.ti.com/video">www.ti.com/video</a>

### TI E2E Community

[e2e.ti.com](http://e2e.ti.com)