

Low Consumption Voltage and Current Controller for Battery Chargers and Adaptors

- Constant voltage and constant current control
- Low consumption
- Low voltage operation
- Low external component count
- Current sink output stage
- Easy compensation
- High ac mains voltage rejection
- 2kV ESD protection (HBM)

Voltage Reference:

- Fixed output voltage reference 1.25V
- 0.5% and 1% Voltage precision

DESCRIPTION

TSM1014 is a highly integrated solution for SMPS applications requiring CV (constant voltage) and CC (constant current) mode.

TSM1014 integrates one voltage reference and two operational amplifiers.

The voltage reference combined with one operational amplifier makes it an ideal voltage controller. The other operational amplifier, combined with few external resistors and the voltage reference, can be used as a current limiter.

APPLICATIONS

- Adapters
- Battery chargers

ORDER CODES

Part Number	Temperature Range	Package	Packaging	VRef (%)	Marking
TSM1014ID	-40 to 105°C	SO-8	Tube	1	M1014
TSM1014IDT			Tape & Reel	1	M1014
TSM1014AID			Tube	0.5	M1014A
TSM1014AIDT			Tape & Reel	0.5	M1014A
TSM1014IST		mini SO-8	Tape & Reel	1	M808
TSM1014AIST			Tape & Reel	0.5	M809

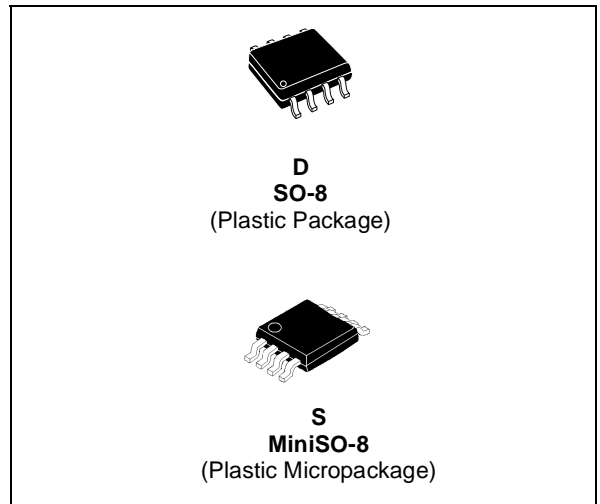

PIN CONNECTIONS (top view)

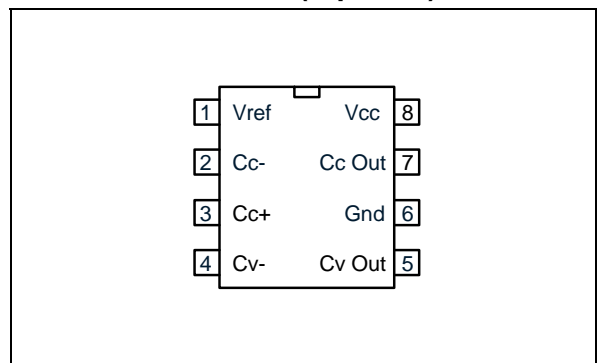

1 Pin Descriptions

The table below gives the pin descriptions for both SO8 & MiniSO8 packages.

Name	Pin #	Type	Function
VRef	1	Analog Output	Voltage Reference
CC-	2	Analog Input	Input pin of the operational amplifier
CC+	3	Analog Input	Input pin of the operational amplifier
CV-	4	Analog Input	Input pin of the operational amplifier
CVOUT	5	Analog Output	Output of the operational amplifier
Gnd	6	Power Supply	Ground Line. 0V Reference For All Voltages
CCOUT	7	Analog Output	Output of the operational amplifier
Vcc	8	Power Supply	Power supply line.

2 Absolute Maximum Ratings

Symbol	DC Supply Voltage	Value	Unit
Vcc	DC Supply Voltage (50mA =< Icc)	-0.3V to Vz	V
Vi	Input Voltage	-0.3 to Vcc	V
PT	Power dissipation		W
Toper	Operational temperature	0 to 105	°C
Tstg	Storage temperature	-55 to 150	°C
Tj	Junction temperature	150	°C
Iref	Voltage reference output current	2.5	mA
ESD	Electrostatic Discharge	2	kV
Rthja	Thermal Resistance Junction to Ambient Mini SO8 package	180	°C/W
Rthja	Thermal Resistance Junction to Ambient SO8 package	175	°C/W

3 Operating Conditions

Symbol	Parameter	Value	Unit
Vcc	DC Supply Conditions	4.5 to Vz	V
Toper	Operational temperature	-40 to 105	°C

4 Electrical Characteristics

$T_{amb} = 25^{\circ}\text{C}$ and $V_{cc} = +18\text{V}$ (unless otherwise specified)

Symbol	Parameter	Test Condition	Min	Typ	Max	Unit
Total Current Consumption						
I_{cc}	Total Supply Current, excluding current in Voltage Reference ¹ .	$V_{cc} = 18\text{V}$, no load $T_{min.} < T_{amb} < T_{max.}$		100	180	μA
V_z	V_{cc} clamp voltage	$I_{cc} = 50\text{mA}$		28		V
Operator 1: Op-amp with non-inverting input connected to the internal VRef						
$V_{Ref+V_{io}}$	Input Offset Voltage + Voltage reference TSM1014	$T_{amb} = 25^{\circ}\text{C}$ $T_{min.} \leq T_{amb} \leq T_{max.}$		1.251	1.266	V
	TSM1014A	$T_{amb} = 25^{\circ}\text{C}$ $T_{min.} \leq T_{amb} \leq T_{max.}$		1.25	1.279 1.258 1.267	
DV_{io}	Input Offset Voltage Drift			7		$\mu\text{V}/^{\circ}\text{C}$
Operator 2						
V_{io}	Input Offset Voltage TSM1014	$T_{amb} = 25^{\circ}\text{C}$ $T_{min.} \leq T_{amb} \leq T_{max.}$		1	4	mV
	TSM1014A	$T_{amb} = 25^{\circ}\text{C}$ $T_{min.} \leq T_{amb} \leq T_{max.}$		0.5	2 3	
DV_{io}	Input Offset Voltage Drift			7		$\mu\text{V}/^{\circ}\text{C}$
I_{ib}	Input Bias Current	$T_{amb} = 25^{\circ}\text{C}$ $T_{min.} \leq T_{amb} \leq T_{max.}$		20 50	150 200	nA
SVR	Supply Voltage Rejection Ratio	$V_{CC} = 4.5\text{V}$ to 28V	65	100		dB
V_{icm}	Input Common Mode Voltage Range		0		$V_{cc}-1.5$	V
CMR	Common Mode Rejection Ratio	$T_{amb} = 25^{\circ}\text{C}$ $T_{min.} \leq T_{amb} \leq T_{max.}$	70	85		dB
			60			
Output stage						
G_m	Transconductance Gain. Sink Current Only ²	$T_{amb} = 25^{\circ}\text{C}$ $T_{min.} \leq T_{amb} \leq T_{max.}$	0.5	1 1		mA/mV
V_{ol}	Low output voltage at 5 mA sinking current	$T_{min.} \leq T_{amb} \leq T_{max.}$		250	400	mV
I_{os}	Output Short Circuit Current. Output to ($V_{cc}-0.6\text{V}$). Sink Current Only	$T_{amb} = 25^{\circ}\text{C}$ $T_{min.} \leq T_{amb} \leq T_{max.}$	6 5	10		mA
Voltage reference						
V_{Ref}	Reference Input Voltage TSM1014 1% precision	$T_{amb} = 25^{\circ}\text{C}$ $T_{min.} \leq T_{amb} \leq T_{max.}$	1.238	1.25	1.262	V
			1.225		1.273	
	TSM1014A 0.5% precision	$T_{amb} = 25^{\circ}\text{C}$ $T_{min.} \leq T_{amb} \leq T_{max.}$	1.244	1.25	1.256	
			1.237		1.261	
ΔV_{Ref}	Reference Input Voltage Deviation Over Temperature Range	$T_{min.} \leq T_{amb} \leq T_{max.}$		20	30	mV
RegLine	Reference input voltage deviation over V_{cc} range.	$I_{load} = 1\text{mA}$			20	mV
RegLoad	Reference input voltage deviation over output current.	$V_{cc} = 18\text{V}$, $0 < I_{load} < 2.5\text{mA}$			10	mV

1) Test conditions: pin 2 and 6 connected to GND, pin 4 and 5 connected to 1.25V, pin 3 connected to 200mV.

2) The current depends on the voltage difference between the negative and the positive inputs of the amplifier. If the voltage on the minus input is 1mV higher than the positive amplifier, the sinking current at the output OUT will be increased by $G_m \cdot 1\text{mA}$.

Figure 1: Internal schematic

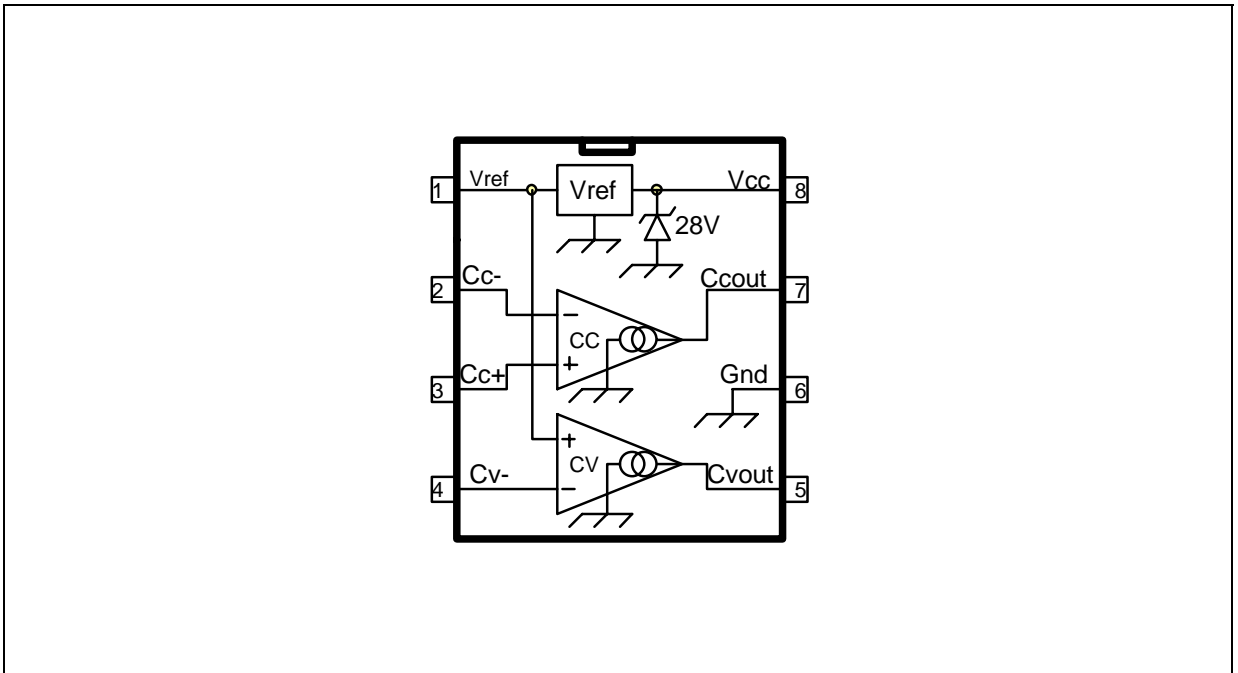
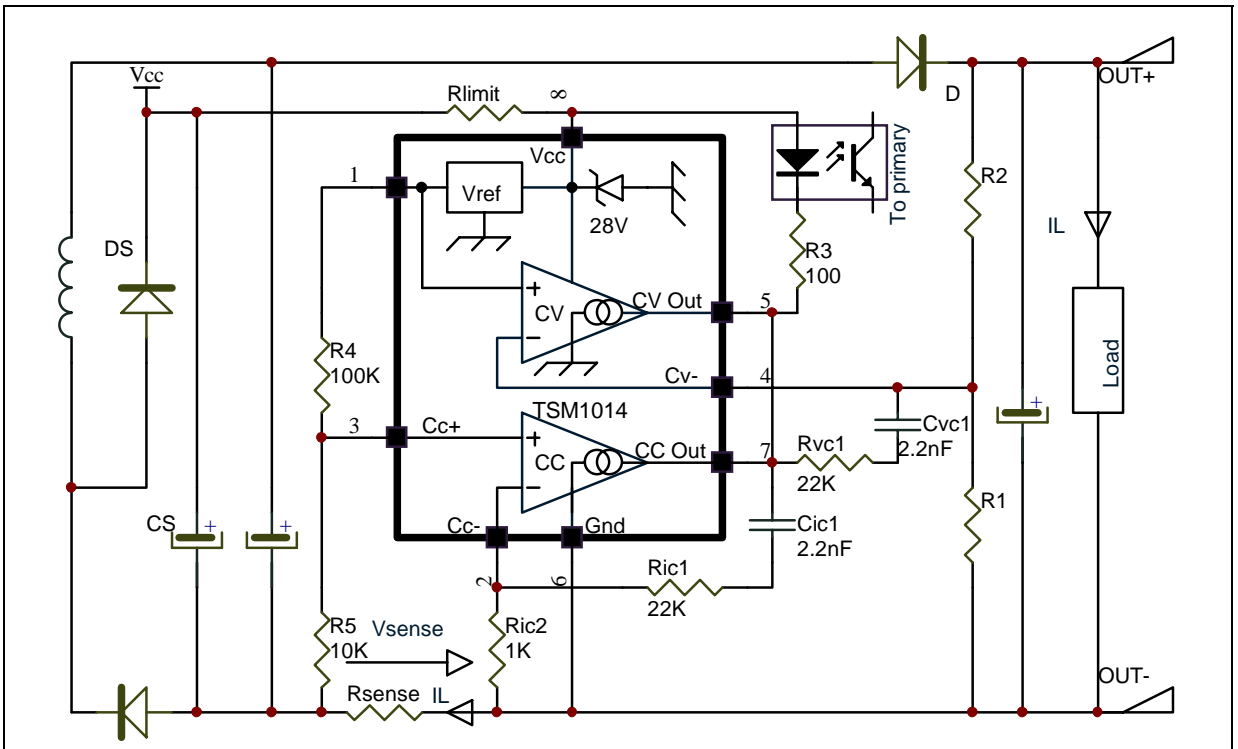

Figure 2: Typical adapter or battery charger application using TSM1014



In the application schematic shown in [Figure 2](#), the TSM1014 is used on the secondary side of a flyback adapter (or battery charger) to provide an accurate voltage and current control. The above feedback loop is made with optocoupler.

5 Principles of Operation and Application Tips

5.1 Voltage control

The voltage loop is controlled via a first trans-conductance operational amplifier, the resistor bridge $R1$, $R2$, and the optocoupler which is directly connected to the output.

The relation between the values of $R1$ and $R2$ should be chosen as written in [Equation 1](#).

$$R1 = R2 \times V_{Ref} / (V_{out} - V_{Ref}) \quad \text{Equation 1}$$

where V_{out} is the desired output voltage.

To avoid the discharge of the load, the resistor bridge $R1$, $R2$ should be highly resistive. For this type of application, a total value of 100K Ω (or more) would be appropriate for the resistors $R1$ and $R2$.

As an example, with $R2 = 100\text{K}\Omega$, $V_{out} = 4.10\text{V}$, $V_{Ref} = 1.210\text{V}$, then $R1 = 41.9\text{K}\Omega$.

Note that if the low drop diode is inserted between the load and the voltage regulation resistor bridge to avoid current flowing from the load through the resistor bridge, this drop should be taken into account in the above calculations by replacing V_{out} by $(V_{out} + V_{drop})$.

5.2 Current control

The current loop is controlled via the second trans-conductance operational amplifier, the sense resistor R_{sense} , and the optocoupler.

V_{sense} threshold is achieved externally by a resistor bridge tied to the V_{Ref} voltage reference. Its middle point is tied to the positive input of the current control operational amplifier, and its foot is to be connected to lower potential point of the sense resistor as shown on the following figure. The resistors of this bridge are matched to provide the best precision possible.

The control equation verifies:

$$R_{sense} \times I_{lim} = V_{sense} \quad \text{Equation 2}$$

$$V_{sense} = \frac{R_5 \cdot V_{ref}}{(R_4 + R_5)}$$

$$I_{lim} = \frac{R_5 \cdot V_{ref} \cdot R_{sense}}{(R_4 + R_5)} \quad \text{Equation 3}$$

where I_{lim} is the desired limited current, and V_{sense} is the threshold voltage for the current control loop.

Note that the R_{sense} resistor should be chosen taking into account the maximum dissipation (P_{lim}) through it during full load operation.

$$P_{lim} = I_{lim} \times V_{sense} \quad \text{Equation 4}$$

Therefore, for most adapter and battery charger applications, a quarter-watt, or half-watt resistor to make the current sensing function is sufficient.

The current sinking outputs of the two trans-conductance operational amplifiers are common (to the output of the IC). This makes an ORing function which ensures that whenever the current or the voltage reaches too high values, the optocoupler is activated.

The relation between the controlled current and the controlled output voltage can be described with a square characteristic as shown in the following V/I output-power graph.

Figure 3: Output Voltage versus Output Current

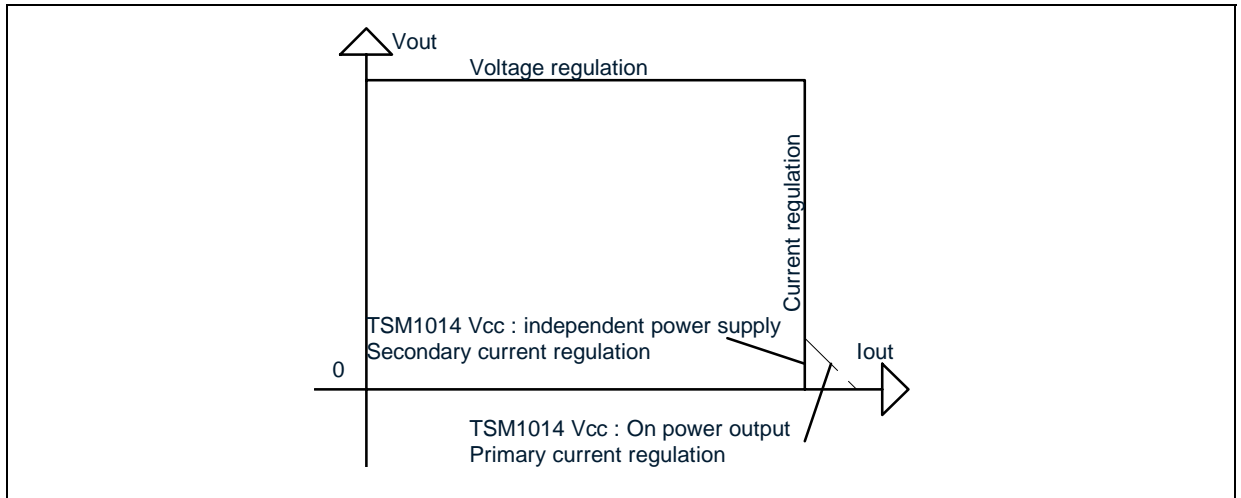

5.3 Compensation

The voltage-control trans-conductance operational amplifier can be fully compensated. Both its output and negative input are directly accessible for external compensation components.

An example of a suitable voltage-control compensation network is shown in [Figure 2](#) on page 4. It consists of a capacitor $C_{vc1}=2.2nF$ and a resistor $R_{cv1}=22K\Omega$ in series.

The current-control trans-conductance operational amplifier can be fully compensated. Both of its output and negative input are directly accessible for external compensation components.

An example of a suitable current-control compensation network is also shown in [Figure 2](#) on page 4. It consists of a capacitor $C_{ic1}=2.2nF$ and a resistor $R_{ic1}=22K\Omega$ in series.

5.4 Start-up and short circuit conditions

Under start-up or short-circuit conditions the TSM1014 is not provided with a high enough supply voltage. This is due to the fact that the chip has its power supply line in common with the power supply line of the system.

Therefore, the current limitation can only be ensured by the primary PWM module, which should be chosen accordingly.

If the primary current limitation is considered not to be precise enough for the application, then a sufficient supply for the TSM1014 has to be ensured under all conditions. For this, it would be necessary to add some circuitry to supply the chip with a separate power line. This can be achieved in a number of ways, including putting an additional winding on the transformer.

5.5 Voltage clamp

The following schematic shows how to realize a low-cost power supply for the TSM1014 (with no additional windings). Please pay attention to the fact that in the particular case presented here, this low-cost power supply can reach voltages as high as twice the voltage of the regulated line. Since the Absolute Maximum Rating of the TSM1014 supply voltage is 28V. In the aim to protect the TSM1014 against such high voltage values an internal zener clamp is integrated.

$$R_{limit} = (V_{cc} - V_z) \cdot I_{Vz}$$

Figure 4: Clamp voltage

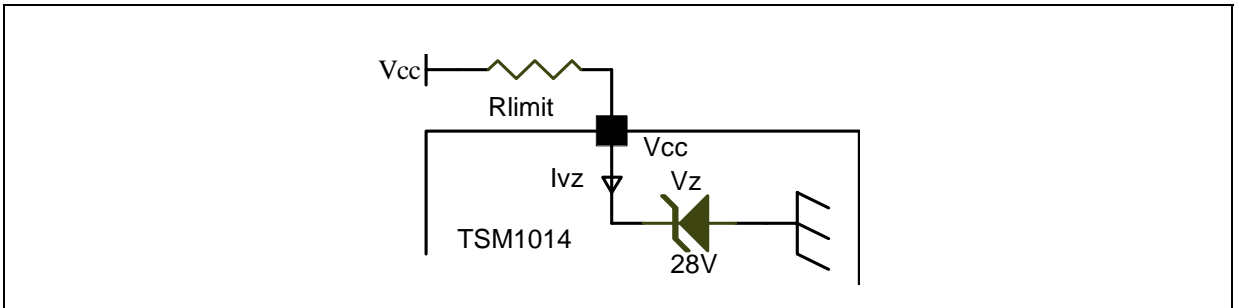
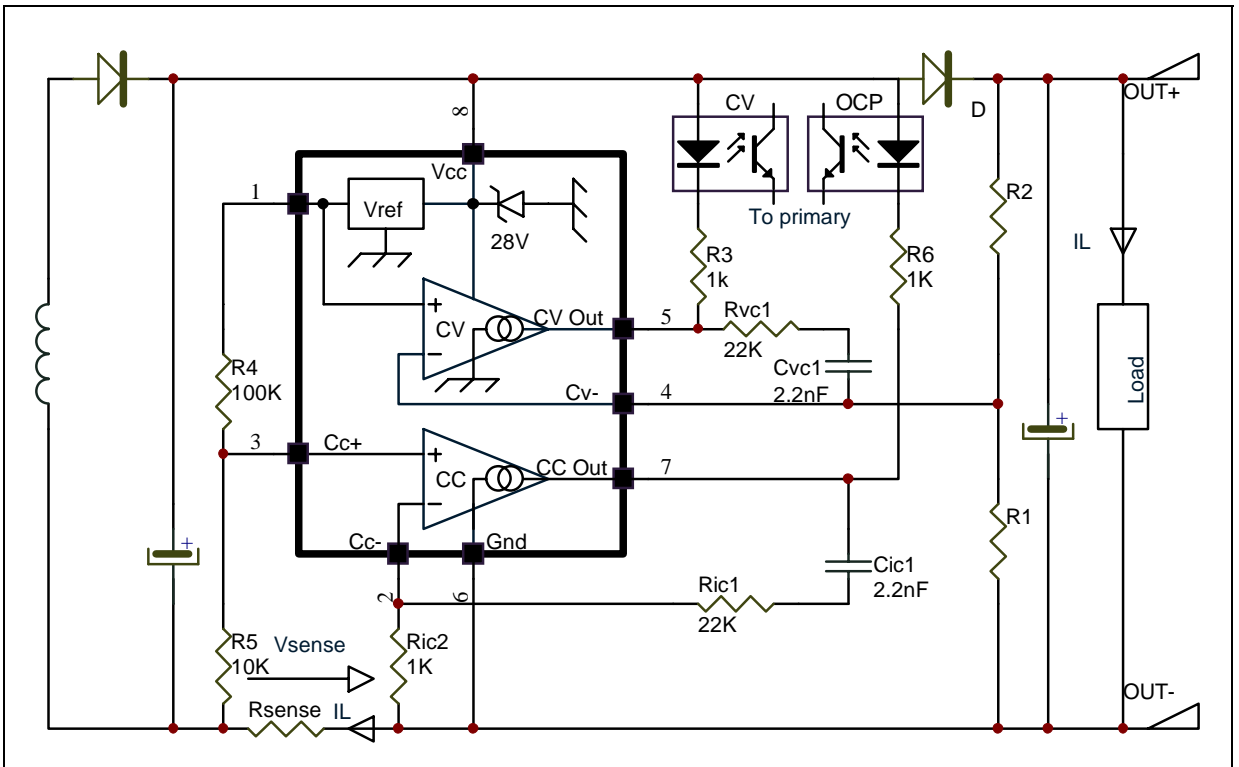

Figure 5: Voltage controller and over current detection schematic



6 Package Mechanical Data

SO-8 MECHANICAL DATA

DIM.	mm.			inch		
	MIN.	TYP	MAX.	MIN.	TYP.	MAX.
A	1.35		1.75	0.053		0.069
A1	0.10		0.25	0.04		0.010
A2	1.10		1.65	0.043		0.065
B	0.33		0.51	0.013		0.020
C	0.19		0.25	0.007		0.010
D	4.80		5.00	0.189		0.197
E	3.80		4.00	0.150		0.157
e		1.27			0.050	
H	5.80		6.20	0.228		0.244
h	0.25		0.50	0.010		0.020
L	0.40		1.27	0.016		0.050
k	8° (max.)					
ddd			0.1			0.04

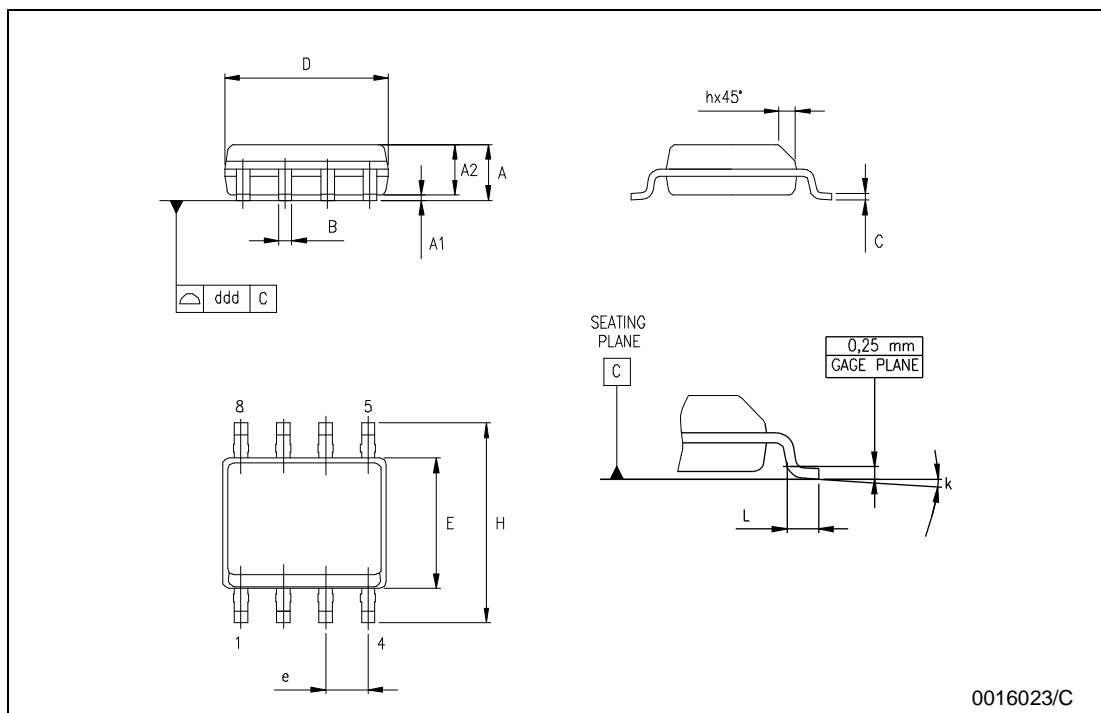

miniSO-8 MECHANICAL DATA

DIM.	mm.			inch		
	MIN.	TYP	MAX.	MIN.	TYP.	MAX.
A			1.1			0.043
A1	0.05	0.10	0.15	0.002	0.004	0.006
A2	0.78	0.86	0.94	0.031	0.031	0.037
b	0.25	0.33	0.40	0.010	0.13	0.013
c	0.13	0.18	0.23	0.005	0.007	0.009
D	2.90	3.00	3.10	0.114	0.118	0.122
E	4.75	4.90	5.05	0.187	0.193	0.199
E1	2.90	3.00	3.10	.0114	0.118	0.122
e		0.65			0.026	
K	0°		6°	0°		6°
L	0.40	0.55	0.70	0.016	0.022	0.028
L1			0.10			0.004

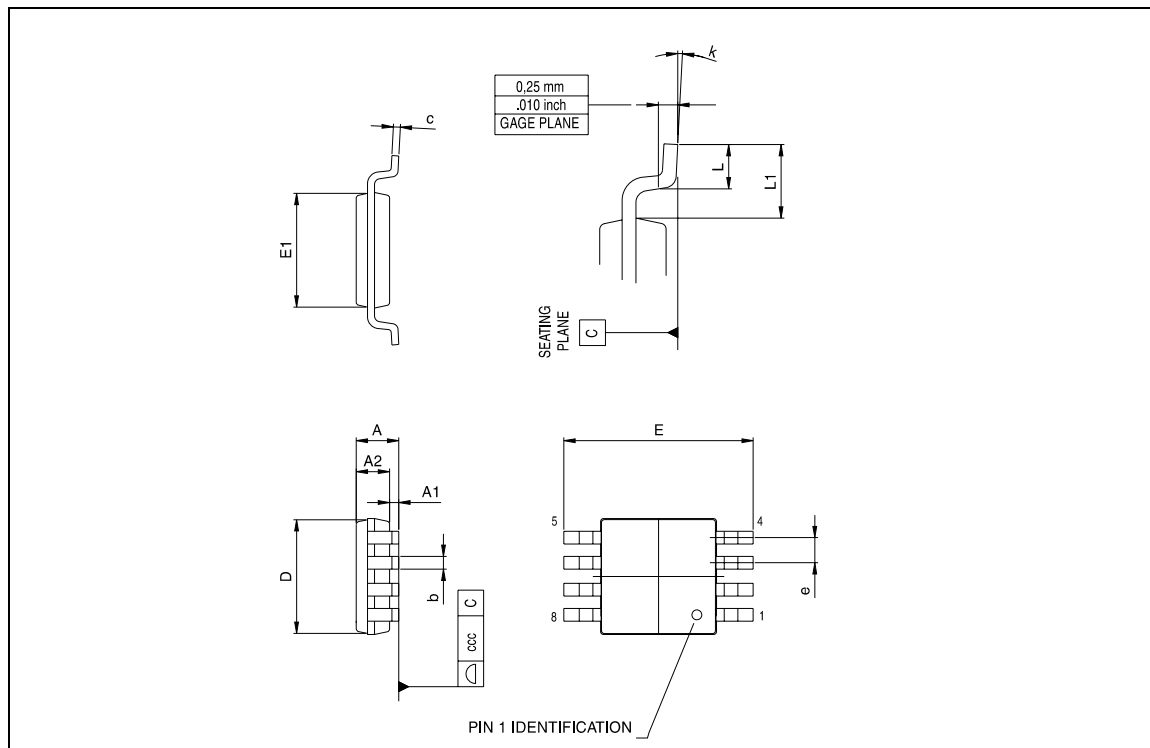

7 Revision History

Date	Revision	Description of Changes
01 July 2004	1	First Release

Information furnished is believed to be accurate and reliable. However, STMicroelectronics assumes no responsibility for the consequences of use of such information nor for any infringement of patents or other rights of third parties which may result from its use. No license is granted by implication or otherwise under any patent or patent rights of STMicroelectronics. Specifications mentioned in this publication are subject to change without notice. This publication supersedes and replaces all information previously supplied. STMicroelectronics products are not authorized for use as critical components in life support devices or systems without express written approval of STMicroelectronics.

The ST logo is a registered trademark of STMicroelectronics
All other names are the property of their respective owners

© 2004 STMicroelectronics - All rights reserved

STMicroelectronics group of companies

Australia - Belgium - Brazil - Canada - China - Czech Republic - Finland - France - Germany - Hong Kong - India - Israel - Italy - Japan - Malaysia - Malta - Morocco - Singapore - Spain - Sweden - Switzerland - United Kingdom - United States of America

www.st.com