



Low Voltage I/O TOUCH SCREEN CONTROLLER

FEATURES

- SAME PINOUT AS ADS7846
- 2.2V TO 5.25V OPERATION
- 1.5V TO 5.25V DIGITAL I/O
- INTERNAL 2.5V REFERENCE
- DIRECT BATTERY MEASUREMENT (0V to 6V)
- ON-CHIP TEMPERATURE MEASUREMENT
- TOUCH-PRESSURE MEASUREMENT
- QSPI™ AND SPI™ 3-WIRE INTERFACE
- AUTO POWER-DOWN
- AVAILABLE IN TSSOP-16, QFN-16, AND VFBGA-48 PACKAGES

APPLICATIONS

- PERSONAL DIGITAL ASSISTANTS
- PORTABLE INSTRUMENTS
- POINT-OF-SALE TERMINALS
- PAGERS
- TOUCH SCREEN MONITORS
- CELLULAR PHONES

US Patent No. 6246394

QSPI and SPI are registered trademarks of Motorola.

DESCRIPTION

The TSC2046 is a next-generation version to the ADS7846 4-wire touch screen controller which supports a low-voltage I/O interface from 1.5V to 5.25V. The TSC2046 is 100% pin-compatible with the existing ADS7846, and will drop into the same socket. This allows for easy upgrade of current applications to the new version. The TSC2046 also has an on-chip 2.5V reference that can be used for the auxiliary input, battery monitor, and temperature measurement modes. The reference can also be powered down when not used to conserve power. The internal reference operates down to 2.7V supply voltage, while monitoring the battery voltage from 0V to 6V.

The low-power consumption of < 0.75mW typ at 2.7V (reference off), high-speed (up to 125kHz sample rate), and on-chip drivers make the TSC2046 an ideal choice for battery-operated systems such as personal digital assistants (PDAs) with resistive touch screens, pagers, cellular phones, and other portable equipment. The TSC2046 is available in TSSOP-16, QFN-16, and VFBGA-48 packages and is specified over the -40°C to +85°C temperature range.

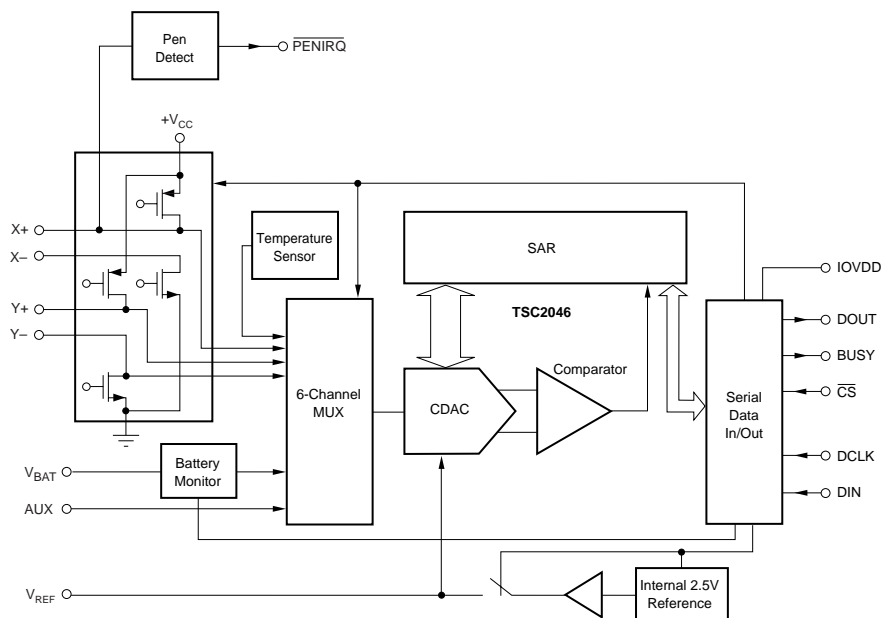

Please be aware that an important notice concerning availability, standard warranty, and use in critical applications of Texas Instruments semiconductor products and disclaimers thereto appears at the end of this data sheet.

ABSOLUTE MAXIMUM RATINGS⁽¹⁾

+V _{CC} and IOVDD to GND	-0.3V to +6V
Analog Inputs to GND	-0.3V to +V _{CC} + 0.3V
Digital Inputs to GND	-0.3V to IOVDD + 0.3V
Power Dissipation	250mW
Maximum Junction Temperature	+150°C
Operating Temperature Range	-40°C to +85°C
Storage Temperature Range	-65°C to +150°C
Lead Temperature (soldering, 10s)	+300°C

NOTE: (1) Stresses above these ratings can cause permanent damage. Exposure to absolute maximum conditions for extended periods may degrade device reliability.



ELECTROSTATIC DISCHARGE SENSITIVITY

This integrated circuit can be damaged by ESD. Texas Instruments recommends that all integrated circuits be handled with appropriate precautions. Failure to observe proper handling and installation procedures can cause damage.

ESD damage can range from subtle performance degradation to complete device failure. Precision integrated circuits may be more susceptible to damage because very small parametric changes could cause the device not to meet its published specifications.

PACKAGE/ORDERING INFORMATION⁽¹⁾

PRODUCT	NOMINAL PENIRQ PULLUP RESISTOR VALUES	MAXIMUM INTEGRAL LINEARITY ERROR (LSB)	PACKAGE-LEAD	PACKAGE DESIGNATOR	SPECIFIED TEMPERATURE RANGE	PACKAGE MARKING	ORDERING NUMBER	TRANSPORT MEDIA, QUANTITY
TSC2046	50kΩ	±2	VFBGA-48	GQC	-40°C to +85°C	AZ2046	TSC2046IGQCR	Tape and Reel, 2500
TSC2046-90	90kΩ	±2	VFBGA-48	GQC	-40°C to +85°C	AZ2046A	TSC2046IGQCR-90	Tape and Reel, 2500
TSC2046	50kΩ	±2	TSSOP-16	PW	-40°C to +85°C	TSC2046I	TSC2046IPW	Rails, 100
"	"	"	"	"	"	"	TSC2046IPWR	Tape and Reel, 2500
TSC2046	50kΩ	±2	QFN-16	RGV	-40°C to +85°C	TSC2046	TSC2046IRGVT	Tape and Reel, 250
"	"	"	"	"	"	"	TSC2046IRGVR	Tape and Reel, 2500

NOTE: (1) For the most current specifications and package information, see the Package Option Addendum located at the end of this data sheet.

ELECTRICAL CHARACTERISTICS

At $T_A = -40^{\circ}\text{C}$ to $+85^{\circ}\text{C}$, $+V_{CC} = +2.7\text{V}$, $V_{REF} = 2.5\text{V}$ internal voltage, $f_{\text{SAMPLE}} = 125\text{kHz}$, $f_{\text{CLK}} = 16 \cdot f_{\text{SAMPLE}} = 2\text{MHz}$, 12-bit mode, digital inputs = GND or IOVDD, and $+V_{CC}$ must be \cdot IOVDD, unless otherwise noted.

PARAMETER	CONDITIONS	TSC2046			UNITS
		MIN	TYP	MAX	
ANALOG INPUT Full-Scale Input Span Absolute Input Range Capacitance Leakage Current	Positive Input-Negative Input Positive Input Negative Input	0 -0.2 -0.2		V_{REF} $+V_{CC} + 0.2$ $+0.2$	V V V pF μA
SYSTEM PERFORMANCE Resolution No Missing Codes Integral Linearity Error Offset Error Gain Error Noise Power-Supply Rejection	External V_{REF} Including Internal V_{REF}	11	12 70 70	± 2 ± 6 ± 4	Bits Bits LSB ⁽¹⁾ LSB LSB μV_{rms} dB
SAMPLING DYNAMICS Conversion Time Acquisition Time Throughput Rate Multiplexer Settling Time Aperture Delay Aperture Jitter Channel-to-Channel Isolation	$V_{IN} = 2.5\text{V}_{\text{p-p}}$ at 50kHz	3		12 125	CLK Cycles CLK Cycles kHz ns ns ps dB
SWITCH DRIVERS On-Resistance Y+, X+ Y-, X- Drive Current ⁽²⁾	Duration 100ms		5 6	50	Ω Ω mA
REFERENCE OUTPUT Internal Reference Voltage Internal Reference Drift Quiescent Current		2.45	2.50 15 500	2.55	V ppm/ $^{\circ}\text{C}$ μA
REFERENCE INPUT Range Input Impedance	SER/DFR = 0, PD1 = 0, Internal Reference Off Internal Reference On	1.0	1 250	$+V_{CC}$	V G Ω Ω
BATTERY MONITOR Input Voltage Range Input Impedance Sampling Battery Battery Monitor Off Accuracy	$V_{BAT} = 0.5\text{V}$ to 5.5V , External $V_{REF} = 2.5\text{V}$ $V_{BAT} = 0.5\text{V}$ to 5.5V , Internal Reference	0.5	10 1	6.0 $+2$ $+3$	V k Ω G Ω % %
TEMPERATURE MEASUREMENT Temperature Range Resolution Accuracy	Differential Method ⁽³⁾ TEMPO ⁽⁴⁾ Differential Method ⁽³⁾ TEMPO ⁽⁴⁾	-40°C	1.6 0.3 ± 2 ± 3	$+85$	$^{\circ}\text{C}$ $^{\circ}\text{C}$ $^{\circ}\text{C}$ $^{\circ}\text{C}$ $^{\circ}\text{C}$
DIGITAL INPUT/OUTPUT Logic Family V_{IH} V_{IL} V_{OH} V_{OL} Data Format	$ I_{IH} \leq +5\mu\text{A}$ $ I_{IL} \leq +5\mu\text{A}$ $I_{OH} = -250\mu\text{A}$ $I_{OL} = 250\mu\text{A}$	IOVDD \cdot 0.7 -0.3 IOVDD \cdot 0.8	CMOS	IOVDD + 0.3 0.3 \cdot IOVDD 0.4	V V V V
POWER-SUPPLY REQUIREMENTS $+V_{CC}$ ⁽⁵⁾ IOVDD ⁽⁶⁾ Quiescent Current ⁽⁷⁾ Power Dissipation	Specified Performance Operating Range Internal Reference Off Internal Reference On $f_{\text{SAMPLE}} = 12.5\text{kHz}$ Power-Down Mode with $\overline{\text{CS}} = \text{DCLK} = \text{DIN} = \text{IOVDD}$ $+V_{CC} = +2.7\text{V}$	2.7 2.2 1.5	280 780 220	3.6 5.25 $+V_{CC}$ 650 3 1.8	V V V μA μA μA μA mW
TEMPERATURE RANGE Specified Performance		-40		$+85$	$^{\circ}\text{C}$

NOTES: (1) LSB means least significant bit. With $V_{REF} = +2.5\text{V}$, one LSB is $610\mu\text{V}$. (2) Assured by design, but not tested. Exceeding 50mA source current may result in device degradation. (3) Difference between TEMPO and TEMP1 measurement, no calibration necessary. (4) Temperature drift is $-2.1\text{mV}/^{\circ}\text{C}$. (5) TSC2046 operates down to 2.2V. (6) IOVDD must be \cdot $+V_{CC}$. (7) Combined supply current from $+V_{CC}$ and IOVDD. Typical values obtained from conversions on AUX input with PD0 = 0.

PIN CONFIGURATION

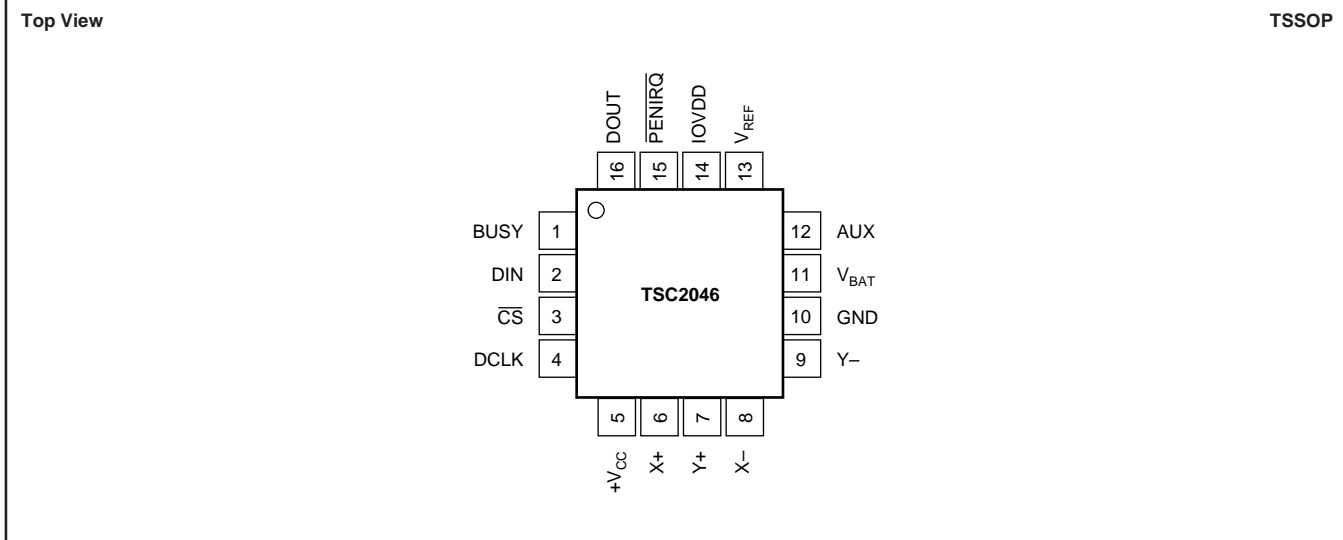
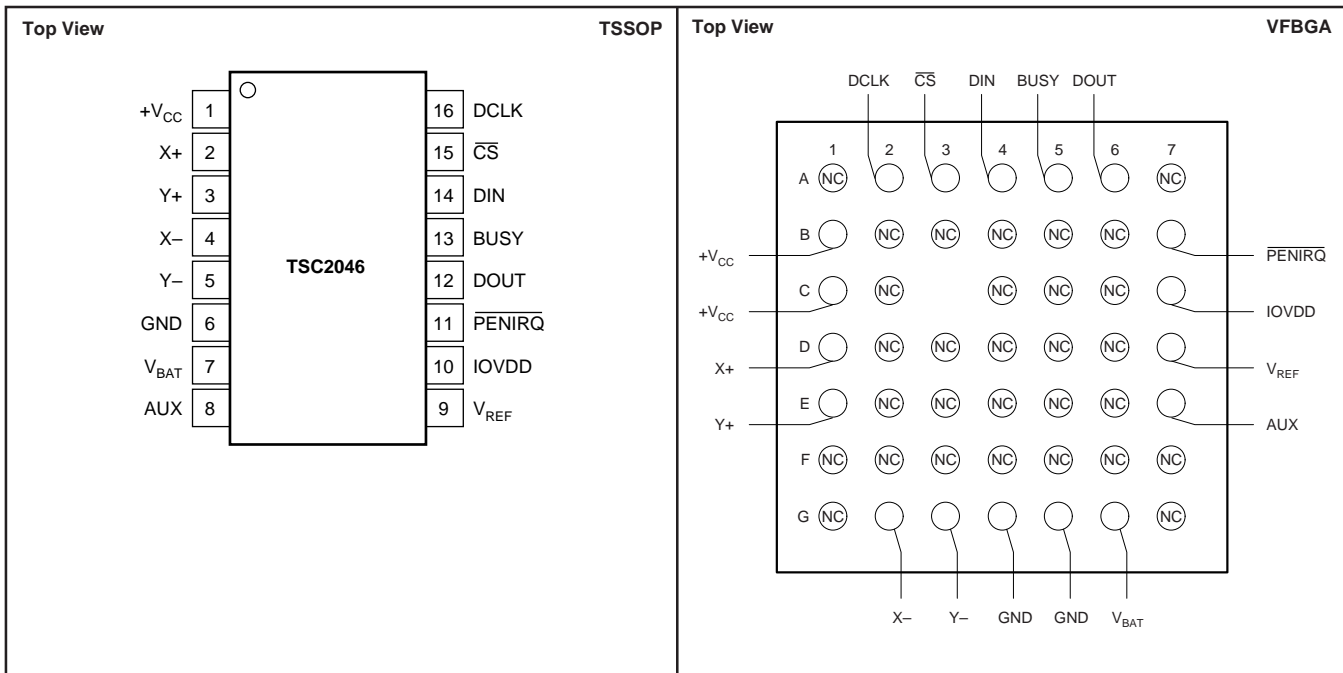

PIN DESCRIPTION

TSSOP PIN #	VFBGA PIN #	QFN PIN #	NAME	DESCRIPTION
1	B1 and C1	5	$+V_{CC}$	Power Supply
2	D1	6	X+	X+ Position Input
3	E1	7	Y+	Y+ Position Input
4	G2	8	X-	X- Position Input
5	G3	9	Y-	Y- Position Input
6	G4 and G5	10	GND	Ground
7	G6	11	V_{BAT}	Battery Monitor Input
8	E7	12	AUX	Auxiliary Input to ADC
9	D7	13	V_{REF}	Voltage Reference Input/Output
10	C7	14	IOVDD	Digital I/O Power Supply
11	B7	15	\overline{PENIRQ}	Pen Interrupt
12	A6	16	DOUT	Serial Data Output. Data is shifted on the falling edge of DCLK. This output is high impedance when \overline{CS} is high.
13	A5	1	BUSY	Busy Output. This output is high impedance when \overline{CS} is high.
14	A4	2	DIN	Serial Data Input. If \overline{CS} is low, data is latched on rising edge of DCLK.
15	A3	3	\overline{CS}	Chip Select Input. Controls conversion timing and enables the serial input/output register. \overline{CS} high = power-down mode (ADC only).
16	A2	4	DCLK	External Clock Input. This clock runs the SAR conversion process and synchronizes serial data I/O.

TYPICAL CHARACTERISTICS

At $T_A = +25^\circ\text{C}$, $+V_{CC} = +2.7\text{V}$, $\text{IOVDD} = +1.8\text{V}$, $V_{REF} = \text{External } +2.5\text{V}$, 12-bit mode, $\text{PD0} = 0$, $f_{\text{SAMPLE}} = 125\text{kHz}$, and $f_{\text{CLK}} = 16 \cdot f_{\text{SAMPLE}} = 2\text{MHz}$, unless otherwise noted.

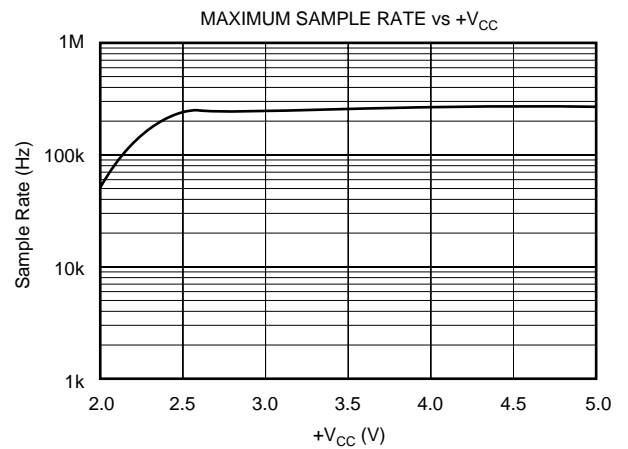
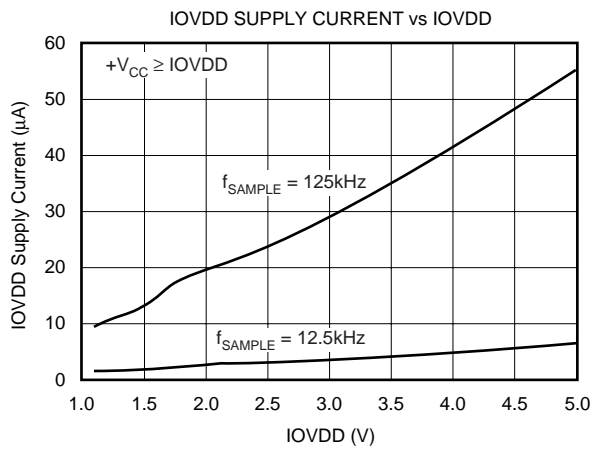
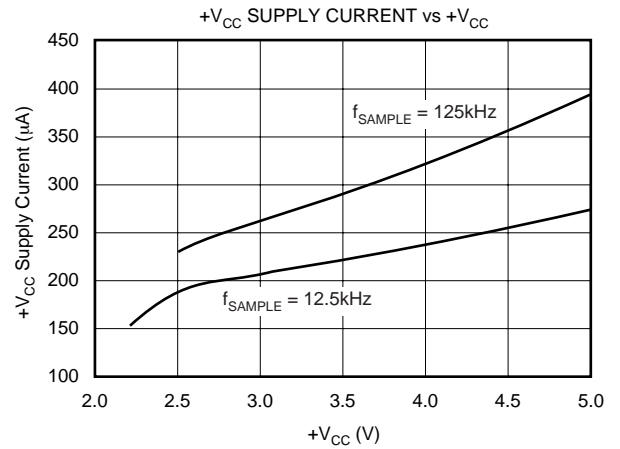
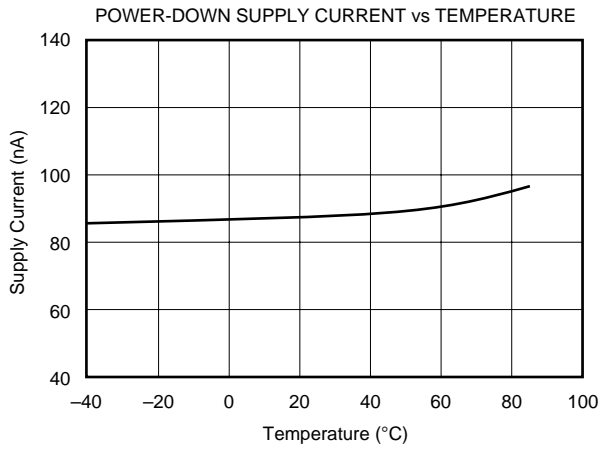
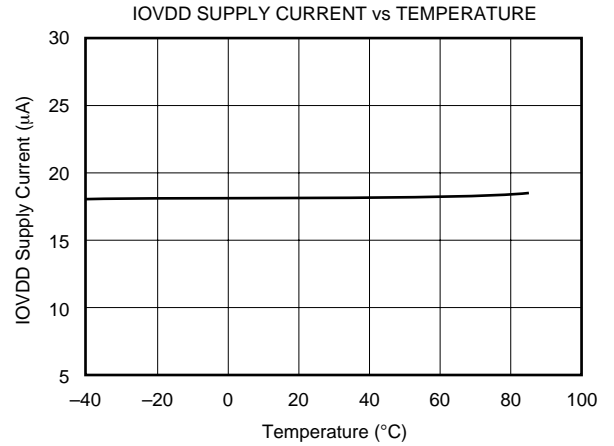
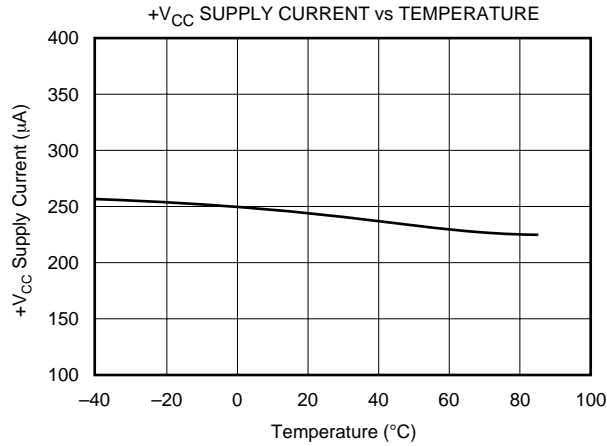

TYPICAL CHARACTERISTICS (Cont.)

At $T_A = +25^\circ\text{C}$, $+V_{CC} = +2.7\text{V}$, $\text{IOVDD} = +1.8\text{V}$, $V_{REF} = \text{External } +2.5\text{V}$, 12-bit mode, $\text{PD0} = 0$, $f_{\text{SAMPLE}} = 125\text{kHz}$, and $f_{\text{CLK}} = 16 \cdot f_{\text{SAMPLE}} = 2\text{MHz}$, unless otherwise noted.

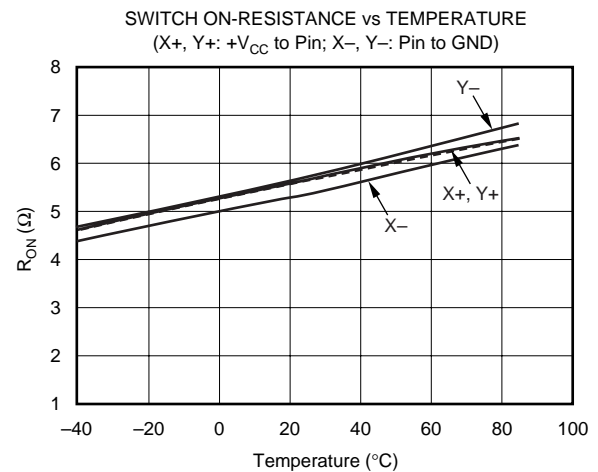
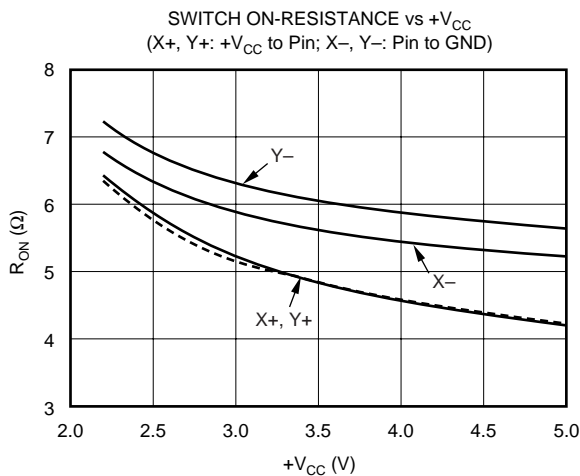
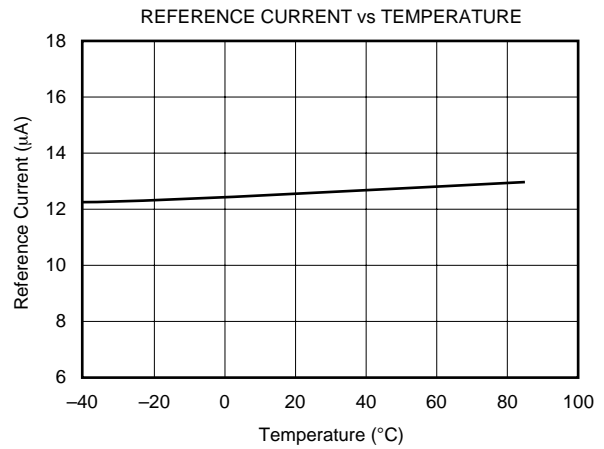
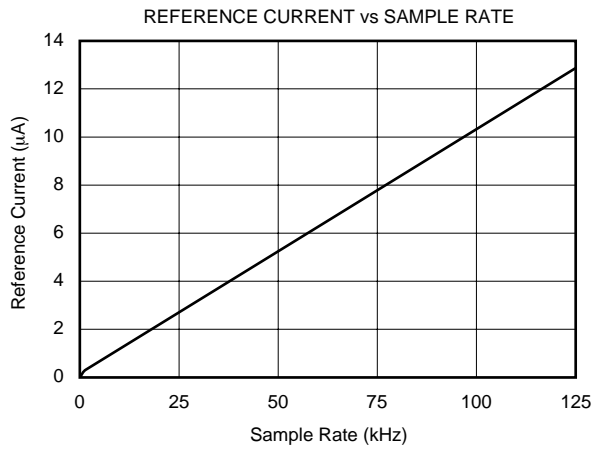
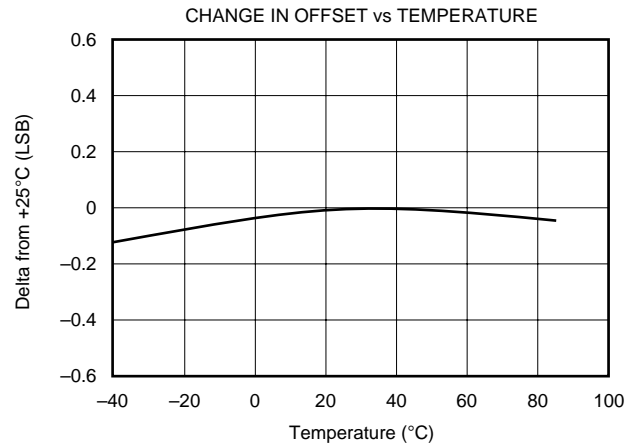
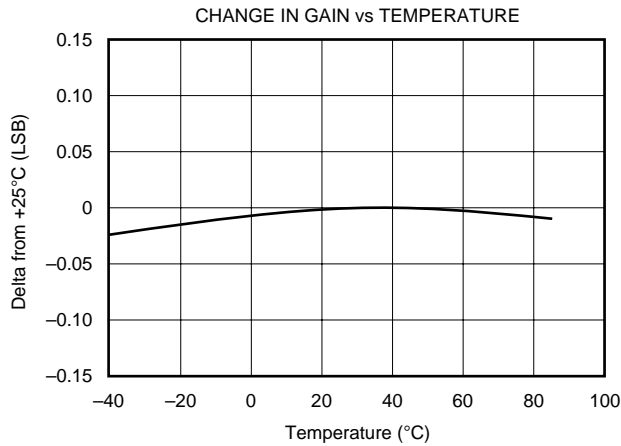

TYPICAL CHARACTERISTICS (Cont.)

At $T_A = +25^\circ\text{C}$, $+V_{CC} = +2.7\text{V}$, $\text{IOVDD} = +1.8\text{V}$, $V_{REF} = \text{External } +2.5\text{V}$, 12-bit mode, $\text{PD0} = 0$, $f_{\text{SAMPLE}} = 125\text{kHz}$, and $f_{\text{CLK}} = 16 \cdot f_{\text{SAMPLE}} = 2\text{MHz}$, unless otherwise noted.

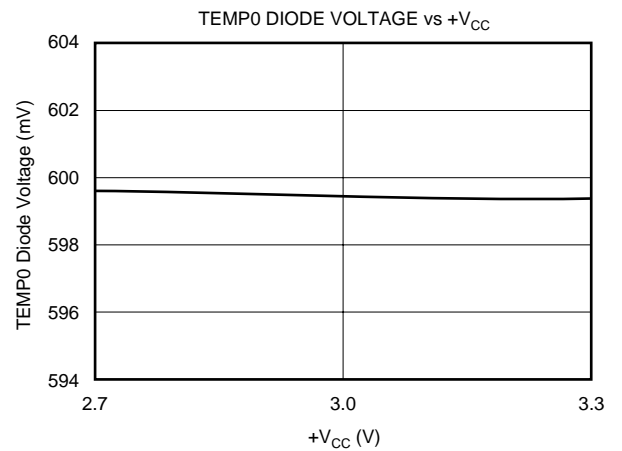
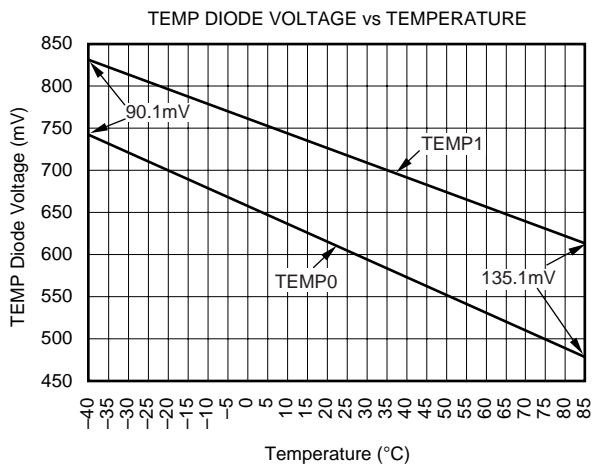
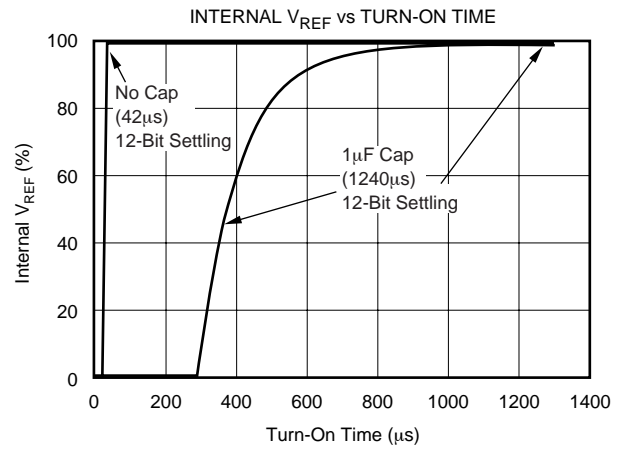
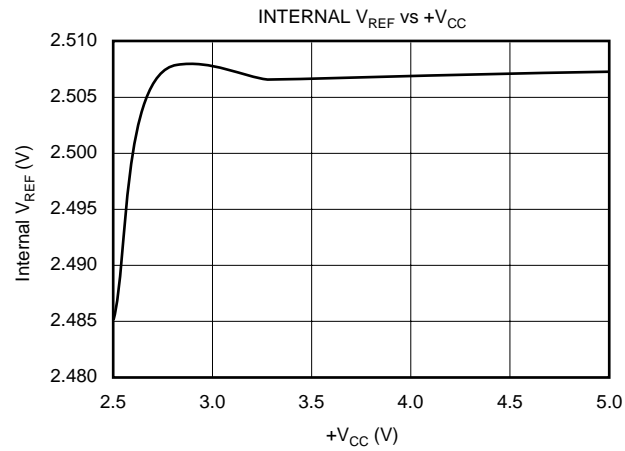
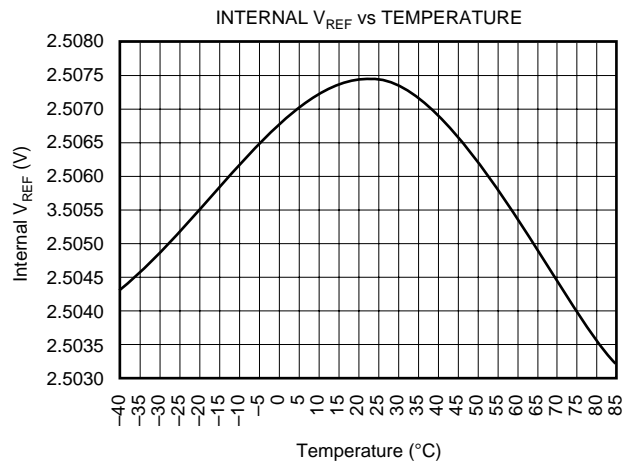
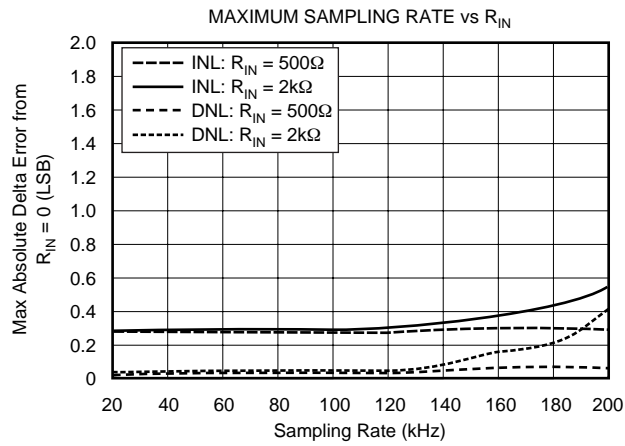

TYPICAL CHARACTERISTICS (Cont.)

At $T_A = +25^\circ\text{C}$, $+V_{CC} = +2.7\text{V}$, $\text{IOVDD} = +1.8\text{V}$, $V_{REF} = \text{External } +2.5\text{V}$, 12-bit mode, $\text{PD0} = 0$, $f_{\text{SAMPLE}} = 125\text{kHz}$, and $f_{\text{CLK}} = 16 \cdot f_{\text{SAMPLE}} = 2\text{MHz}$, unless otherwise noted.

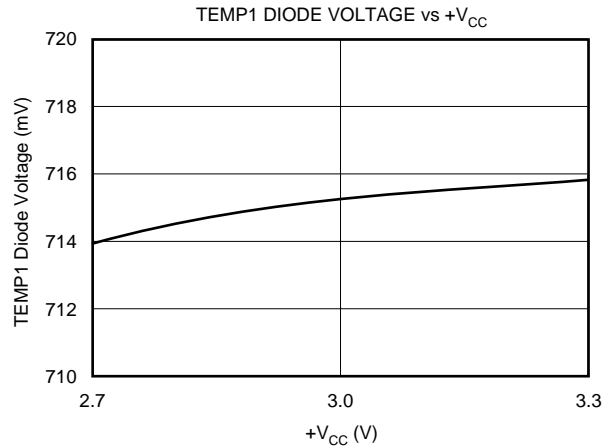

THEORY OF OPERATION

The TSC2046 is a classic successive approximation register (SAR) analog-to-digital converter (ADC). The architecture is based on capacitive redistribution, which inherently includes a sample-and-hold function. The converter is fabricated on a $0.6\mu\text{m}$ CMOS process.

The basic operation of the TSC2046 is shown in Figure 1. The device features an internal 2.5V reference and uses an external clock. Operation is maintained from a single supply of 2.7V to 5.25V. The internal reference can be overdriven with an external, low-impedance source between 1V and

$+V_{CC}$. The value of the reference voltage directly sets the input range of the converter.

The analog input (X-, Y-, and Z-Position coordinates, auxiliary input, battery voltage, and chip temperature) to the converter is provided via a multiplexer. A unique configuration of low on-resistance touch panel driver switches allows an unselected ADC input channel to provide power and the accompanying pin to provide ground for an external device, such as a touch screen. By maintaining a differential input to the converter and a differential reference architecture, it is possible to negate the error from each touch panel driver switch's on-resistance (if this is a source of error for the particular measurement).

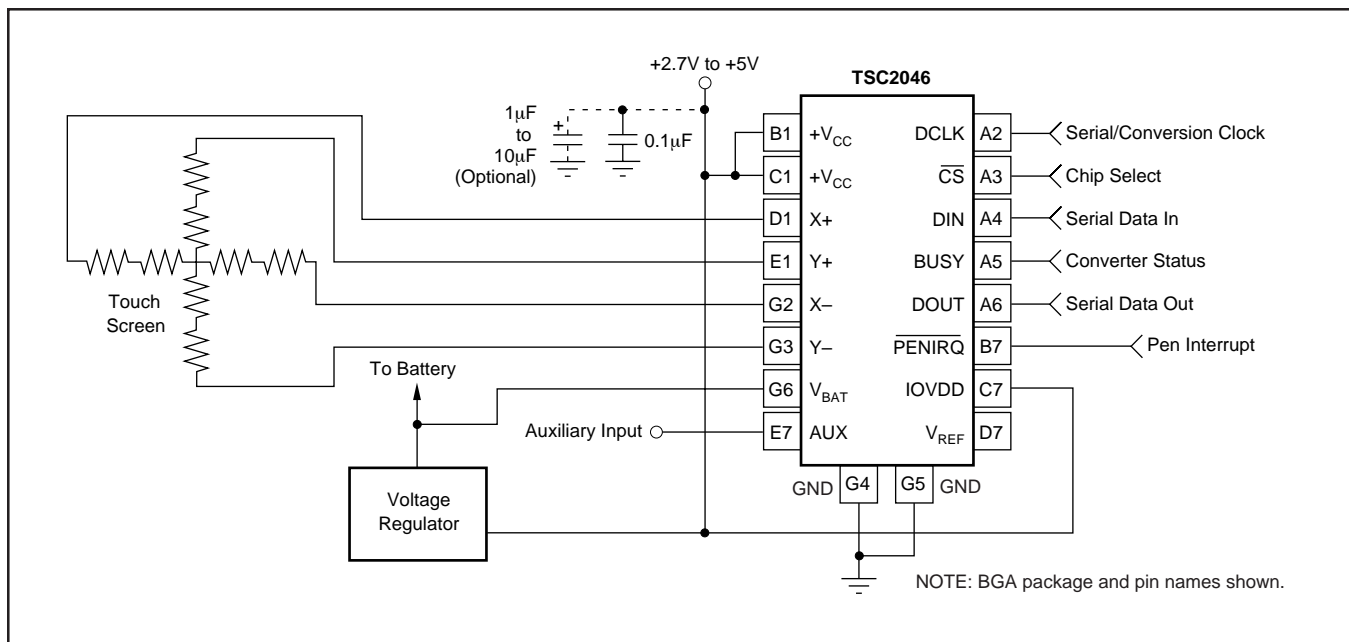

FIGURE 1. Basic Operation of the TSC2046.

ANALOG INPUT

Figure 2 shows a block diagram of the input multiplexer on the TSC2046, the differential input of the ADC, and the differential reference of the converter. Table I and Table II show the relationship between the A2, A1, A0, and SER/DFR control bits and the configuration of the TSC2046. The control bits are provided serially via the DIN pin—see the Digital Interface section of this data sheet for more details.

When the converter enters the hold mode, the voltage difference between the +IN and -IN inputs (as shown in Figure 2) is captured on the internal capacitor array. The input current into the analog inputs depends on the conversion rate of the device. During the sample period, the source must charge the internal sampling capacitor (typically 25pF). After the capacitor has been fully charged, there is no further input current. The rate of charge transfer from the analog source to the converter is a function of conversion rate.

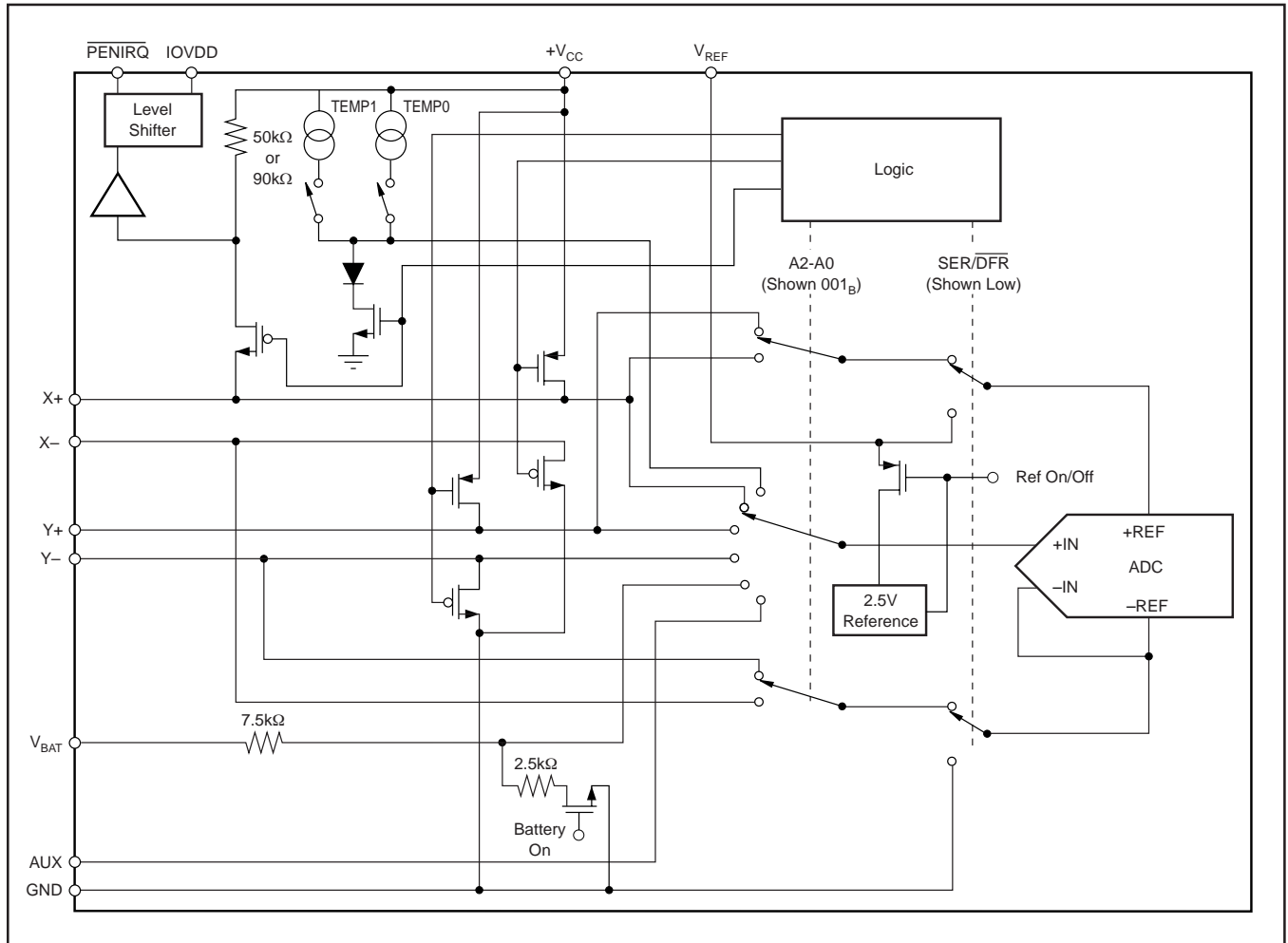

FIGURE 2. Simplified Diagram of Analog Input.

A2	A1	A0	V _{BAT}	AUX _{IN}	TEMP	Y-	X+	Y+	Y-POSITION	X-POSITION	Z ₁ -POSITION	Z ₂ -POSITION	X-DRIVERS	Y-DRIVERS
0	0	0	+IN		+IN (TEMP0)		+IN		Measure		Measure	Measure	Off	Off
0	0	1											Off	On
0	1	0											Off	Off
0	1	1											X-, On	Y+, On
1	0	0	+IN		+IN (TEMP1)	+IN		Measure		Measure	Measure	X-, On	Y+, On	
1	0	1										On	Off	
1	1	0										Off	Off	
1	1	1										Off	Off	

TABLE I. Input Configuration (DIN), Single-Ended Reference Mode (SER/DFR high).

A2	A1	A0	+REF	-REF	Y-	X+	Y+	Y-POSITION	X-POSITION	Z ₁ -POSITION	Z ₂ -POSITION	DRIVERS ON
0	0	1	Y+	Y-	+IN	+IN	+IN	Measure		Measure	Measure	Y+, Y-
0	1	1	Y+	X-		Y+, X-						
1	0	0	Y+	X-		Y+, X-						
1	0	1	X+	X-		X+, X-						

TABLE II. Input Configuration (DIN), Differential Reference Mode (SER/DFR low).

INTERNAL REFERENCE

The TSC2046 has an internal 2.5V voltage reference that can be turned on or off with the control bit, PD1 (see Table V and Figure 3). Typically, the internal reference voltage is only used in the single-ended mode for battery monitoring, temperature measurement, and for using the auxiliary input. Optimal touch screen performance is achieved when using the differential mode. The internal reference voltage of the TSC2046 must be commanded to be off to maintain compatibility with the ADS7843. Therefore, after power-up, a write of PD1 = 0 is required to insure the reference is off (see the Typical Characteristics for power-up time of the reference from power-down).

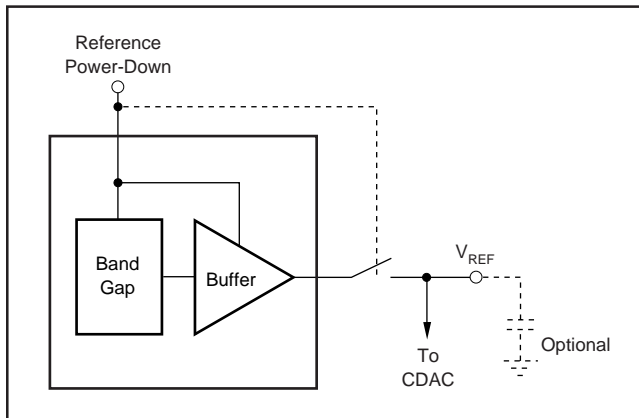

FIGURE 3. Simplified Diagram of the Internal Reference.

REFERENCE INPUT

The voltage difference between +REF and -REF (see Figure 2) sets the analog input range. The TSC2046 operates with a reference in the range of 1V to +V_{CC}. There are several critical items concerning the reference input and its wide voltage range. As the reference voltage is reduced, the analog voltage weight of each digital output code is also reduced. This is often referred to as the LSB (least significant bit) size and is equal to the reference voltage divided by 4096 in 12-bit mode. Any offset or gain error inherent in the ADC appears to increase, in terms of LSB size, as the reference voltage is reduced. For example, if the offset of a given converter is 2LSBs with a 2.5V reference, it is typically 5LSBs with a 1V reference. In each case, the actual offset of the device is the same, 1.22mV. With a lower reference voltage, more care must be taken to provide a clean layout including adequate bypassing, a clean (low-noise, low-ripple) power supply, a low-noise reference (if an external reference is used), and a low-noise input signal.

The voltage into the V_{REF} input directly drives the capacitor digital-to-analog converter (CDAC) portion of the TSC2046. Therefore, the input current is very low (typically < 13μA).

There is also a critical item regarding the reference when making measurements while the switch drivers are ON. For this discussion, it is useful to consider the basic operation of the TSC2046, (see Figure 1). This particular application shows the device being used to digitize a resistive touch screen. A measurement of the current Y-Position of the pointing device

is made by connecting the X+ input to the ADC, turning on the Y+ and Y- drivers, and digitizing the voltage on X+ (Figure 4 shows a block diagram). For this measurement, the resistance in the X+ lead does not affect the conversion (it does affect the settling time, but the resistance is usually small enough that this is not a concern). However, since the resistance between Y+ and Y- is fairly low, the on-resistance of the Y drivers does make a small difference. Under the situation outlined so far, it is not possible to achieve a 0V input or a full-scale input regardless of where the pointing device is on the touch screen because some voltage is lost across the internal switches. In addition, the internal switch resistance is unlikely to track the resistance of the touch screen, providing an additional source of error.

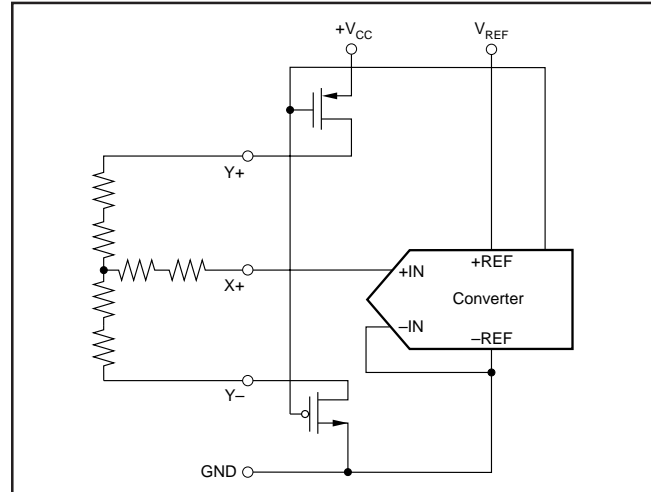

FIGURE 4. Simplified Diagram of Single-Ended Reference (SER/DFR high, Y switches enabled, X+ is analog input).

This situation can be remedied as shown in Figure 5. By setting the SER/DFR bit low, the +REF and -REF inputs are connected directly to Y+ and Y-, respectively, which makes the analog-to-digital conversion ratiometric. The result of the conversion is

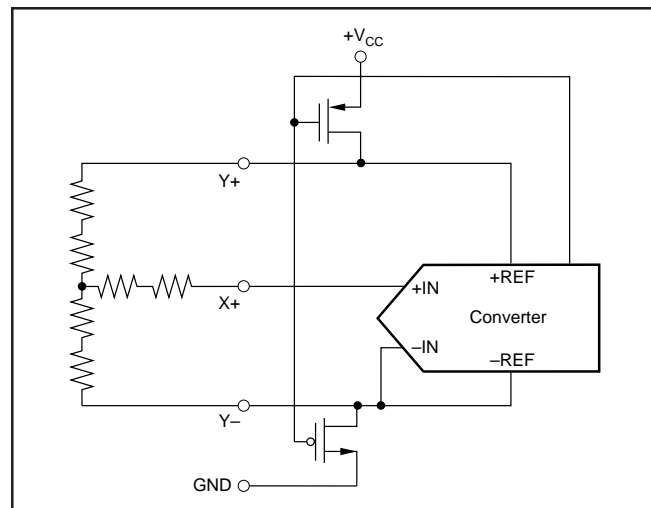

FIGURE 5. Simplified Diagram of Differential Reference (SER/DFR low, Y switches enabled, X+ is analog input).

always a percentage of the external resistance, regardless of how it changes in relation to the on-resistance of the internal switches. Note that there is an important consideration regarding power dissipation when using the ratiometric mode of operation (see the Power Dissipation section for more details).

As a final note about the differential reference mode, it must be used with $+V_{CC}$ as the source of the $+REF$ voltage and cannot be used with V_{REF} . It is possible to use a high-precision reference on V_{REF} and single-ended reference mode for measurements which do not need to be ratiometric. In some cases, it is possible to power the converter directly from a precision reference. Most references can provide enough power for the TSC2046, but might not be able to supply enough current for the external load (such as a resistive touch screen).

TOUCH SCREEN SETTling

In some applications, external capacitors may be required across the touch screen for filtering noise picked up by the touch screen (e.g., noise generated by the LCD panel or backlight circuitry). These capacitors provide a low-pass filter to reduce the noise, but cause a settling time requirement when the panel is touched that typically shows up as a gain error. There are several methods for minimizing or eliminating this issue. The problem is the input and/or reference has not settled to the final steady-state value prior to the ADC sampling the input(s) and providing the digital output. Additionally, the reference voltage may still be changing during the measurement cycle. Option 1 is to stop or slow down the TSC2046 DCLK for the required touch screen settling time. This allows the input and reference to have stable values for the Acquire period (3 clock cycles of the TSC2046; see Figure 9). This works for both the single-ended and the differential modes. Option 2 is to operate the TSC2046 in the differential mode only for the touch screen measurements and command the TSC2046 to remain on (touch screen drivers ON) and not go into power-down ($PD0 = 1$). Several conversions are made depending on the settling time required and the TSC2046 data rate. Once the required number of conversions have been made, the processor commands the TSC2046 to go into its power-down state on the last measurement. This process is required for X-Position, Y-Position, and Z-Position measurements. Option 3 is to operate in the 15 Clock-per-Conversion mode, which overlaps the analog-to-digital conversions and maintains the touch screen drivers on until commanded to stop by the processor (see Figure 13).

TEMPERATURE MEASUREMENT

In some applications, such as battery recharging, a measurement of ambient temperature is required. The temperature measurement technique used in the TSC2046 relies on the characteristics of a semiconductor junction operating at a fixed current level. The forward diode voltage (V_{BE}) has a well-defined characteristic versus temperature. The ambient temperature can be predicted in applications by knowing the $+25^{\circ}\text{C}$ value of the V_{BE} voltage and then monitoring the delta of that voltage as the temperature changes. The TSC2046

offers two modes of operation. The first mode requires calibration at a known temperature, but only requires a single reading to predict the ambient temperature. A diode is used (turned on) during this measurement cycle. The voltage across the diode is connected through the MUX for digitizing the forward bias voltage by the ADC with an address of $A2 = 0$, $A1 = 0$, and $A0 = 0$ (see Table 1 and Figure 6 for details). This voltage is typically 600mV at $+25^{\circ}\text{C}$ with a $20\mu\text{A}$ current through the diode. The absolute value of this diode voltage can vary a few millivolts. However, the TC of this voltage is very consistent at $-2.1\text{mV}/^{\circ}\text{C}$. During the final test of the end product, the diode voltage would be stored at a known room temperature, in memory, for calibration purposes by the user. The result is an equivalent temperature measurement resolution of $0.3^{\circ}\text{C}/\text{LSB}$ (in 12-bit mode).

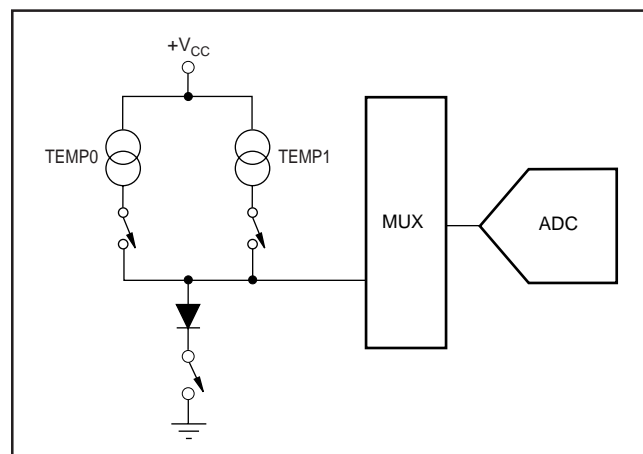

FIGURE 6. Functional Block Diagram of Temperature Measurement Mode.

The second mode does not require a test temperature calibration, but uses a two-measurement method to eliminate the need for absolute temperature calibration and for achieving 2°C accuracy. This mode requires a second conversion with an address of $A2 = 1$, $A1 = 1$, and $A0 = 1$, with a 91 times larger current. The voltage difference between the first and second conversion using 91 times the bias current is represented by $kT/q \cdot \ln(N)$, where N is the current ratio = 91, k = Boltzmann's constant ($1.38054 \cdot 10^{-23}$ electron volts/degrees Kelvin), q = the electron charge ($1.602189 \cdot 10^{-19}$ C), and T = the temperature in degrees Kelvin. This method can provide improved absolute temperature measurement over the first mode at the cost of less resolution ($1.6^{\circ}\text{C}/\text{LSB}$). The equation for solving for $^{\circ}\text{K}$ is:

$$^{\circ}\text{K} = q \cdot \Delta V / (k \cdot \ln(N)) \quad (1)$$

where, $\Delta V = V(I_{91}) - V(I_1)$ (in mV)

$$\therefore ^{\circ}\text{K} = 2.573 \text{ }^{\circ}\text{K}/\text{mV} \cdot \Delta V$$

$$^{\circ}\text{C} = 2.573 \cdot \Delta V(\text{mV}) - 273^{\circ}\text{K}$$

NOTE: The bias current for each diode temperature measurement is only on for 3 clock cycles (during the acquisition mode) and, therefore, does not add any noticeable increase in power, especially if the temperature measurement only occurs occasionally.

BATTERY MEASUREMENT

An added feature of the TSC2046 is the ability to monitor the battery voltage on the other side of the voltage regulator (DC/DC converter), as shown in Figure 7. The battery voltage can vary from 0V to 6V, while maintaining the voltage to the TSC2046 at 2.7V, 3.3V, etc. The input voltage (V_{BAT}) is divided down by 4 so that a 5.5V battery voltage is represented as 1.375V to the ADC. This simplifies the multiplexer and control logic. In order to minimize the power consumption, the divider is only on during the sampling period when $A2 = 0$, $A1 = 1$, and $A0 = 0$ (see Table I for the relationship between the control bits and configuration of the TSC2046).

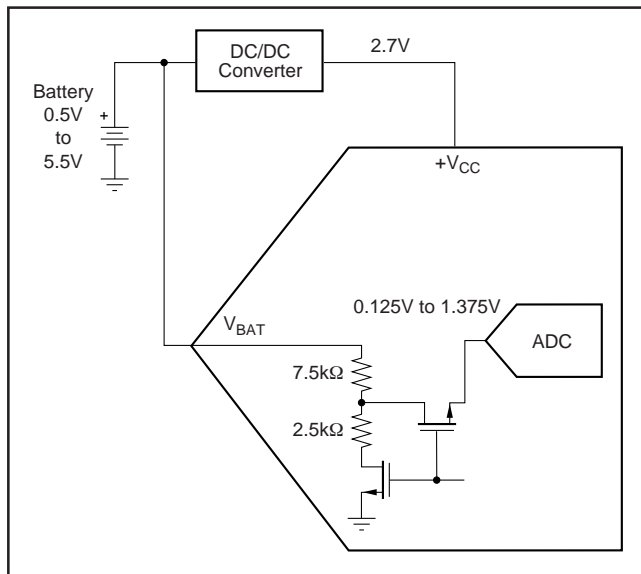

FIGURE 7. Battery Measurement Functional Block Diagram.

PRESSURE MEASUREMENT

Measuring touch pressure can also be done with the TSC2046. To determine pen or finger touch, the pressure of the touch needs to be determined. Generally, it is not necessary to have very high performance for this test, therefore, the 8-bit resolution mode is recommended (however, calculations will be shown here in the 12-bit resolution mode). There are several different ways of performing this measurement. The TSC2046 supports two methods. The first method requires knowing the X-plate resistance, measurement of the X-Position, and two additional cross panel measurements (Z_1 and Z_2) of the touch screen, as shown in Figure 8. Using Equation 2 calculates the touch resistance:

$$R_{TOUCH} = R_{X-plate} \cdot \frac{X-Position}{4096} \left(\frac{Z_2}{Z_1} - 1 \right) \quad (2)$$

The second method requires knowing both the X-plate and Y-plate resistance, measurement of X-Position and Y-Position, and Z_1 . Using Equation 3 also calculates the touch resistance:

$$R_{TOUCH} = \frac{R_{X-plate} \cdot X-Position}{4096} \left(\frac{4096}{Z_1} - 1 \right) - R_{Y-plate} \left(1 - \frac{Y-Position}{4096} \right) \quad (3)$$

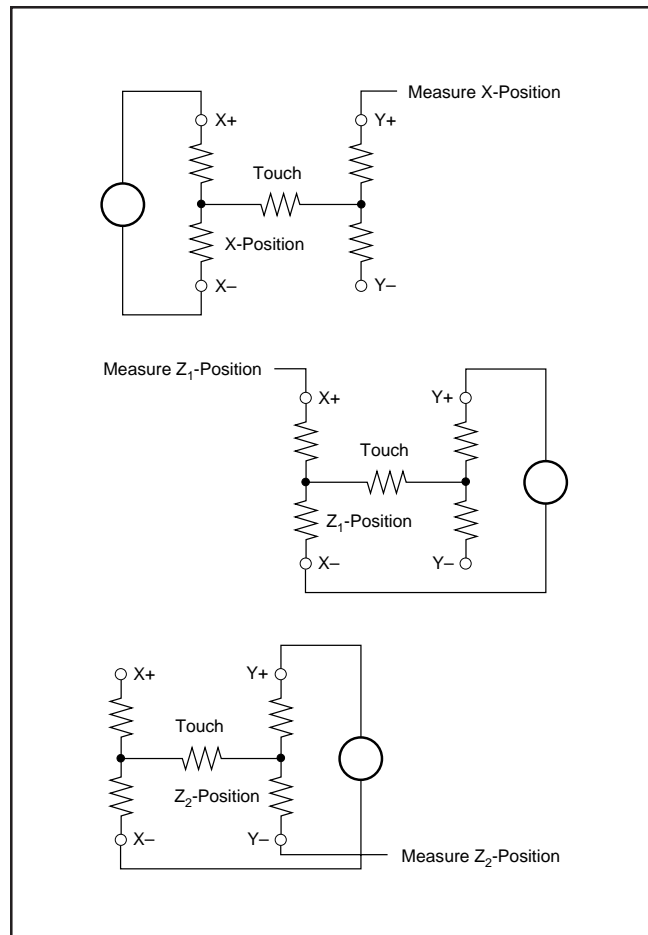

FIGURE 8. Pressure Measurement Block Diagrams.

DIGITAL INTERFACE

See Figure 9 for the typical operation of the TSC2046 digital interface. This diagram assumes that the source of the digital signals is a microcontroller or digital signal processor with a basic serial interface. Each communication between the processor and the converter, such as SPI, SSI, or Microwire™ synchronous serial interface, consists of eight clock cycles. One complete conversion can be accomplished with three serial communications for a total of 24 clock cycles on the DCLK input.

The first eight clock cycles are used to provide the control byte via the DIN pin. When the converter has enough information about the following conversion to set the input multiplexer and reference inputs appropriately, the converter enters the acquisition (sample) mode and, if needed, the touch panel drivers are turned on. After three more clock cycles, the control byte is complete and the converter enters the conversion mode. At this point, the input sample-and-hold goes into the hold mode and the touch panel drivers turn off (in single-ended mode). The next 12 clock cycles accomplish the actual analog-to-digital conversion. If the conversion is ratiometric ($SER/DFR = 0$), the drivers are on during the conversion and a 13th clock cycle is needed for the last bit of the conversion result. Three more clock cycles are needed to complete the last byte (DOUT will be low), which are ignored by the converter.

Microwire is a registered trademark of National Semiconductor.

Control Byte

The control byte (on DIN), as shown in Table III, provides the start conversion, addressing, ADC resolution, configuration, and power-down of the TSC2046. Figure 9 and Tables III and IV give detailed information regarding the order and description of these control bits within the control byte.

Bit 7 (MSB)	Bit 6	Bit 5	Bit 4	Bit 3	Bit 2	Bit 1	Bit 0 (LSB)
S	A2	A1	A0	MODE	SER/DFR	PD1	PD0

TABLE III. Order of the Control Bits in the Control Byte.

BIT	NAME	DESCRIPTION
7	S	Start bit. Control byte starts with first high bit on DIN. A new control byte can start every 15th clock cycle in 12-bit conversion mode or every 11th clock cycle in 8-bit conversion mode (see Figure 13).
6-4	A2-A0	Channel Select bits. Along with the SER/DFR bit, these bits control the setting of the multiplexer input, touch driver switches, and reference inputs (see Tables I and II).
3	MODE	12-Bit/8-Bit Conversion Select bit. This bit controls the number of bits for the next conversion: 12-bits (low) or 8-bits (high).
2	SER/DFR	Single-Ended/Differential Reference Select bit. Along with bits A2-A0, this bit controls the setting of the multiplexer input, touch driver switches, and reference inputs (see Tables I and II).
1-0	PD1-PD0	Power-Down Mode Select bits. Refer to Table V for details.

TABLE IV. Descriptions of the Control Bits within the Control Byte.

Initiate START—The first bit, the S bit, must always be high and initiates the start of the control byte. The TSC2046 ignores inputs on the DIN pin until the start bit is detected.

Addressing—The next three bits (A2, A1, and A0) select the active input channel(s) of the input multiplexer (see Tables I, II, and Figure 2), touch screen drivers, and the reference inputs.

MODE—The mode bit sets the resolution of the ADC. With this bit low, the next conversion has 12 bits of resolution, whereas with this bit high, the next conversion has 8 bits of resolution.

SER/DFR—The SER/DFR bit controls the reference mode, either single-ended (high) or differential (low). The differential mode is also referred to as the ratiometric conversion mode and is preferred for X-Position, Y-Position, and Pressure-Touch measurements for optimum performance. The reference is derived from the voltage at the switch drivers, which is almost the same as the voltage to the touch screen. In this case, a reference voltage is not needed as the reference voltage to the ADC is the voltage across the touch screen. In the single-ended mode, the converter reference voltage is always the difference between the V_{REF} and GND pins (see Tables I and II, and Figures 2 through 5 for further information).

If X-Position, Y-Position, and Pressure-Touch are measured in the single-ended mode, an external reference voltage is needed. The TSC2046 must also be powered from the external reference. Caution should be observed when using the single-ended mode such that the input voltage to the ADC does not exceed the internal reference voltage, especially if the supply voltage is greater than 2.7V.

NOTE: The differential mode can only be used for X-Position, Y-Position, and Pressure-Touch measurements. All other measurements require the single-ended mode.

PD0 and PD1—Table V describes the power-down and the internal reference voltage configurations. The internal reference voltage can be turned on or off independently of the ADC. This can allow extra time for the internal reference voltage to settle to the final value prior to making a conversion. Make sure to also allow this extra wake-up time if the internal reference is powered down. The ADC requires no wake-up time and can be instantaneously used. Also note

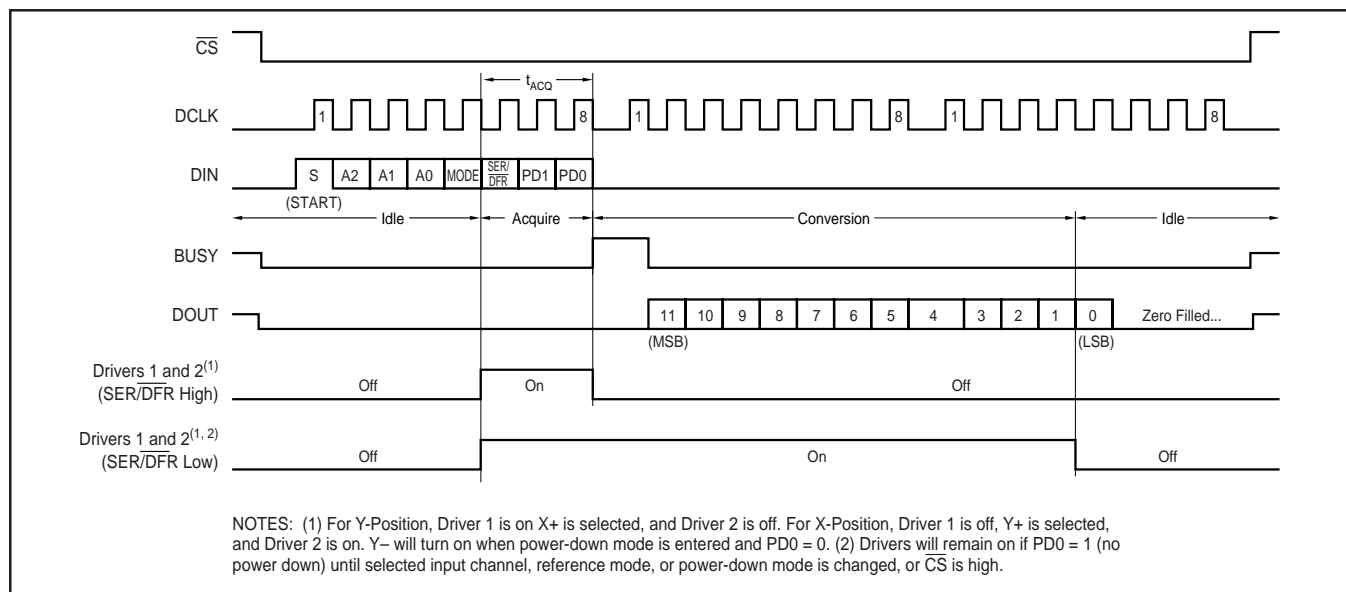

FIGURE 9. Conversion Timing, 24 Clocks-per-Conversion, 8-Bit Bus Interface. No DCLK delay required with dedicated serial port.

PD1	PD0	PENIRQ	DESCRIPTION
0	0	Enabled	Power-Down Between Conversions. When each conversion is finished, the converter enters a low-power mode. At the start of the next conversion, the device instantly powers up to full power. There is no need for additional delays to ensure full operation, and the very first conversion is valid. The Y- switch is on when in power-down.
0	1	Disabled	Reference is off and ADC is on.
1	0	Enabled	Reference is on and ADC is off.
1	1	Disabled	Device is always powered. Reference is on and ADC is ON.

TABLE V. Power-Down and Internal Reference Selection.

that the status of the internal reference power-down is latched into the part (internally) with BUSY going high. In order to turn the reference off, an additional write to the TSC2046 is required after the channel has been converted.

PENIRQ OUTPUT

The pen-interrupt output function is shown in Figure 10. While in power-down mode with PD0 = 0, the Y- driver is on and connects the Y-plane of the touch screen to GND. The PENIRQ output is connected to the X+ input through two transmission gates. When the screen is touched, the X+ input is pulled to ground through the touch screen.

In most of the TSC2046 models, the internal pullup resistor value is nominally 50kΩ, but this may vary between 36kΩ and 67kΩ given process and temperature variations. In order to assure a logic low of 0.35VDD is presented to the PENIRQ circuitry, the total resistance between the X+ and Y- terminals must be less than 21kΩ.

The -90 version of the TSC2046 uses a nominal 90kΩ pullup resistor, which allows the total resistance between the X+ and Y- terminals to be as high as 30kΩ. Note that the higher pullup resistance will cause a slower response time of the PENIRQ to a screen touch, so user software should take this into account.

The PENIRQ output goes low due to the current path through the touch screen to ground, which initiates an interrupt to the

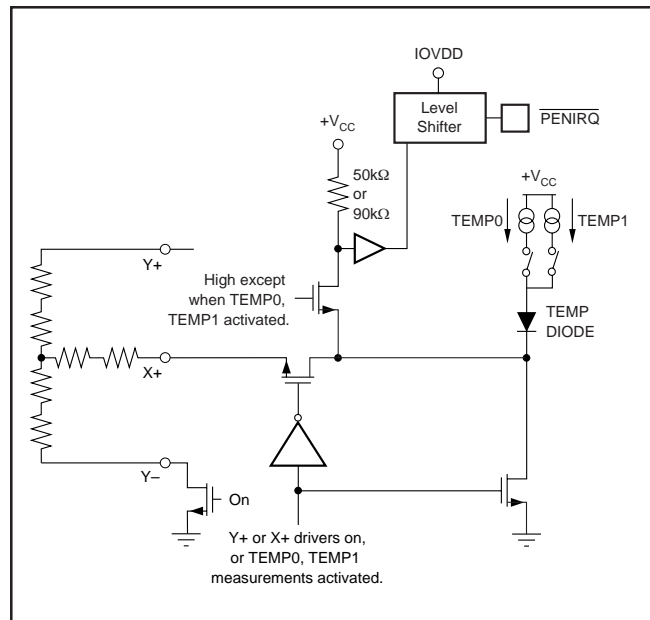

FIGURE 10. PENIRQ Functional Block Diagram.

processor. During the measurement cycle for X-, Y-, and Z-Position, the X+ input is disconnected from the PENIRQ internal pull-up resistor. This is done to eliminate any leakage current from the internal pull-up resistor through the touch screen, thus causing no errors.

Furthermore, the PENIRQ output is disabled and low during the measurement cycle for X-, Y-, and Z-Position. The PENIRQ output is disabled and high during the measurement cycle for battery monitor, auxiliary input, and chip temperature. If the last control byte written to the TSC2046 contains PD0 = 1, the pen-interrupt output function is disabled and is not able to detect when the screen is touched. In order to re-enable the pen-interrupt output function under these circumstances, a control byte needs to be written to the TSC2046 with PD0 = 0. If the last control byte written to the TSC2046 contains PD0 = 0, the pen-interrupt output function is enabled at the end of the conversion. The end of the conversion occurs on the falling edge of DCLK after bit 1 of the converted data is

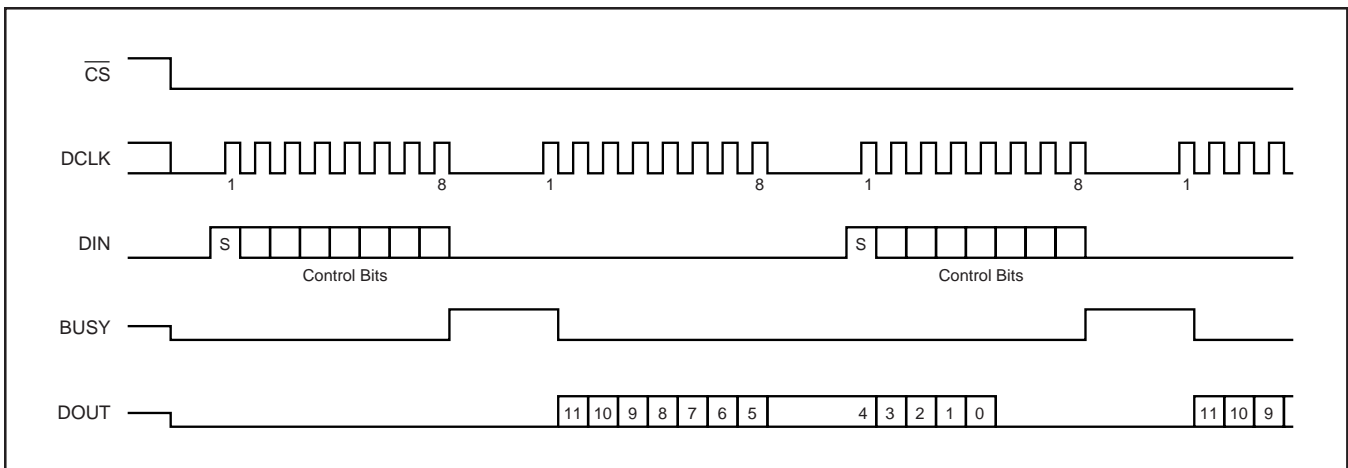

FIGURE 11. Conversion Timing, 16 Clocks-per-Conversion, 8-Bit Bus Interface. No DCLK delay required with dedicated serial port.

clocked out of the TSC2046.

It is recommended that the processor mask the interrupt $\overline{\text{PENIRQ}}$ is associated with whenever the processor sends a control byte to the TSC2046. This prevents false triggering of interrupts when the $\overline{\text{PENIRQ}}$ output is disabled in the cases discussed in this section.

16 Clocks-per-Conversion

The control bits for conversion $n + 1$ can be overlapped with conversion n to allow for a conversion every 16 clock cycles, as shown in Figure 11. This figure also shows possible serial communication occurring with other serial peripherals between each byte transfer from the processor to the converter. This is possible, provided that each conversion completes within 1.6ms of starting. Otherwise, the signal that is captured on the input sample-and-hold may droop enough to affect the conversion result. Note that the TSC2046 is fully powered while other serial communications are taking place during a conversion.

SYMBOL	DESCRIPTION	+V _{CC} • 2.7V, +V _{CC} • IOVDD • 1.5V, C _{LOAD} = 50pF			UNITS
		MIN	TYP	MAX	
t _{ACQ}	Acquisition Time	1.5			μs
t _{DS}	DIN Valid Prior to DCLK Rising	100			ns
t _{DH}	DIN Hold After DCLK High	50			ns
t _{DO}	DCLK Falling to DOUT Valid			200	ns
t _{DV}	$\overline{\text{CS}}$ Falling to DOUT Enabled			200	ns
t _{TR}	$\overline{\text{CS}}$ Rising to DOUT Disabled			200	ns
t _{CSS}	$\overline{\text{CS}}$ Falling to First DCLK Rising	100			ns
t _{CSH}	$\overline{\text{CS}}$ Rising to DCLK Ignored	10			ns
t _{CH}	DCLK High	200			ns
t _{CL}	DCLK Low	200			ns
t _{BD}	DCLK Falling to BUSY Rising/Falling			200	ns
t _{BDV}	$\overline{\text{CS}}$ Falling to BUSY Enabled			200	ns
t _{BTR}	$\overline{\text{CS}}$ Rising to BUSY Disabled			200	ns

TABLE VI. Timing Specifications, T_A = -40°C to +85°C.

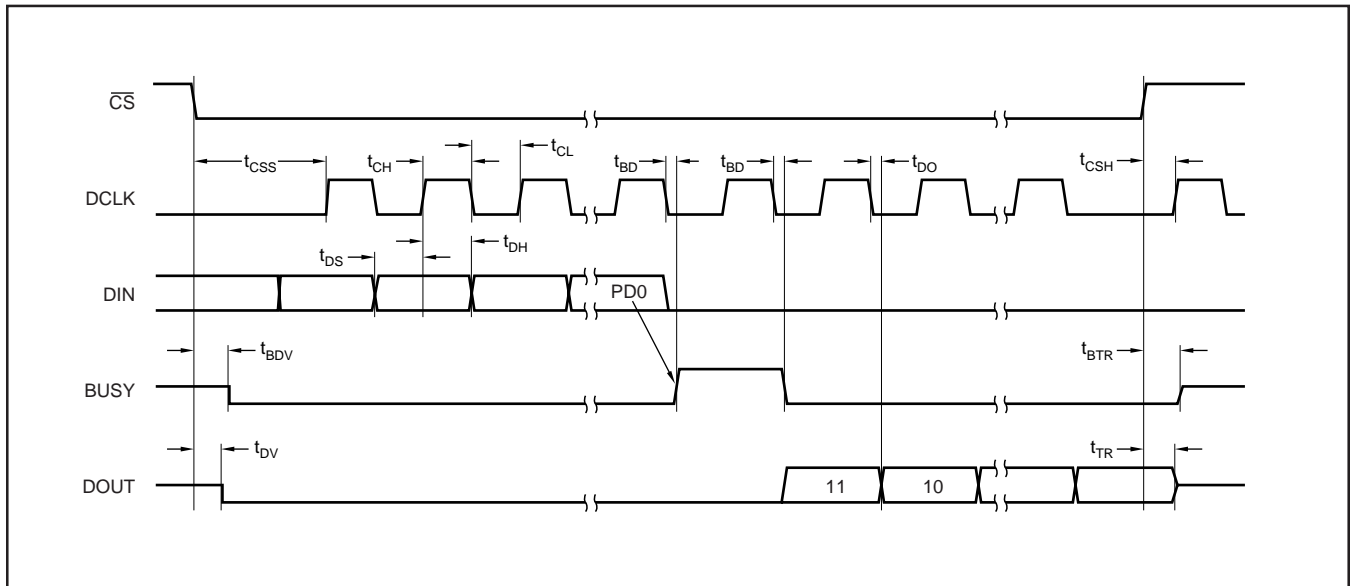

FIGURE 12. Detailed Timing Diagram.

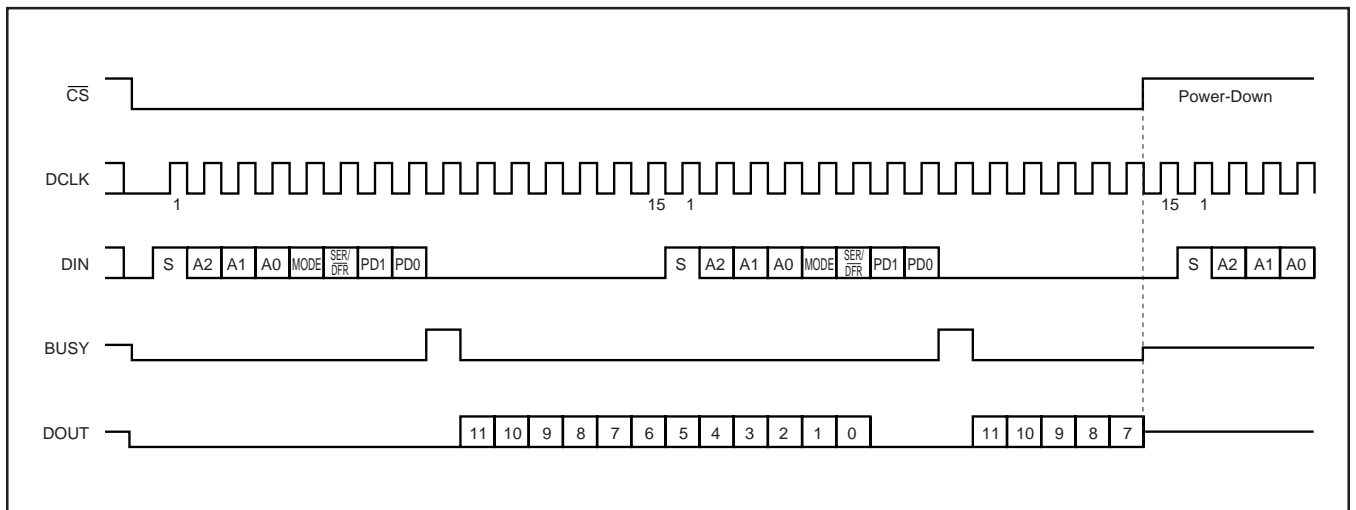

FIGURE 13. Maximum Conversion Rate, 15 Clocks-per-Conversion.

Digital Timing

Figures 9 and 12 and Table VI provide detailed timing for the digital interface of the TSC2046.

15 Clocks-per-Conversion

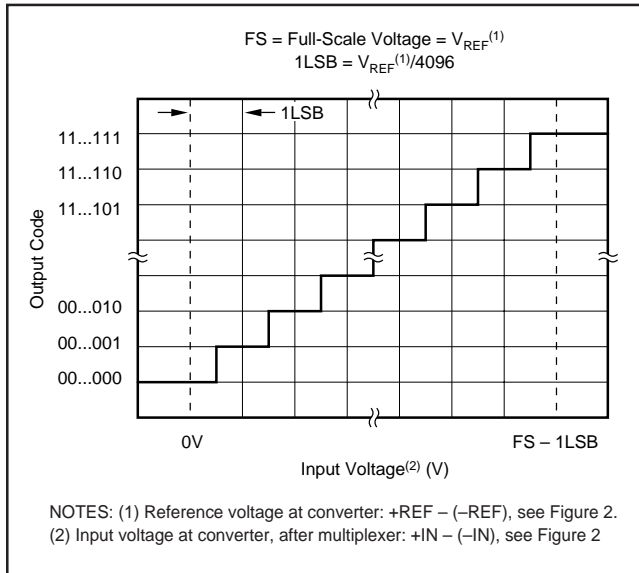

FIGURE 14. Ideal Input Voltages and Output Codes.

Figure 13 provides the fastest way to clock the TSC2046. This method does not work with the serial interface of most microcontrollers and digital signal processors, as they are generally not capable of providing 15 clock cycles per serial transfer. However, this method can be used with field programmable gate arrays (FPGAs) or application specific integrated circuits (ASICs). Note that this effectively increases the maximum conversion rate of the converter beyond the values given in the specification tables, which assume 16 clock cycles per conversion.

Data Format

The TSC2046 output data is in Straight Binary format, as shown in Figure 14. This figure shows the ideal output code for the given input voltage and does not include the effects of offset, gain, or noise.

8-Bit Conversion

The TSC2046 provides an 8-bit conversion mode that can be used when faster throughput is needed and the digital result is not as critical. By switching to the 8-bit mode, a conversion is complete four clock cycles earlier. Not only does this shorten each conversion by four bits (25% faster throughput), but each conversion can actually occur at a faster clock rate. This is because the internal settling time of the TSC2046 is not as critical—settling to better than 8 bits is all that is needed. The clock rate can be as much as 50% faster. The faster clock rate and fewer clock cycles combine to provide a 2x increase in conversion rate.

POWER DISSIPATION

There are two major power modes for the TSC2046: full-power (PD0 = 1) and auto power-down (PD0 = 0). When operating at full speed and 16 clocks-per-conversion (see Figure 11), the TSC2046 spends most of the time acquiring or converting. There is little time for auto power-down, assuming that this mode is active. Therefore, the difference between full-power mode and auto power-down is negligible. If the conversion rate

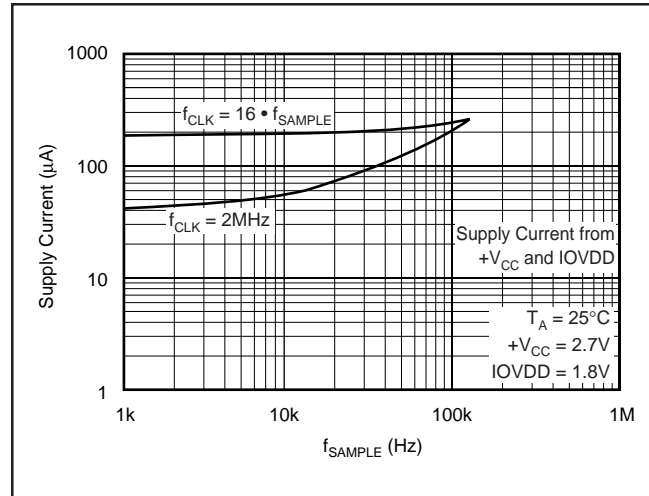

FIGURE 15. Supply Current versus Directly Scaling the Frequency of DCLK with Sample Rate or Maintaining DCLK at the Maximum Possible Frequency.

is decreased by slowing the frequency of the DCLK input, the two modes remain approximately equal. However, if the DCLK frequency is kept at the maximum rate during a conversion but conversions are done less often, the difference between the two modes is dramatic.

Figure 15 shows the difference between reducing the DCLK frequency (scaling DCLK to match the conversion rate) or maintaining DCLK at the highest frequency and reducing the number of conversions per second. In the latter case, the converter spends an increasing percentage of time in power-down mode (assuming the auto power-down mode is active).

Another important consideration for power dissipation is the reference mode of the converter. In the single-ended reference mode, the touch panel drivers are ON only when the analog input voltage is being acquired (see Figure 9 and Table I). The external device (e.g., a resistive touch screen), therefore, is only powered during the acquisition period. In the differential reference mode, the external device must be powered throughout the acquisition and conversion periods (see Figure 9). If the conversion rate is high, this could substantially increase power dissipation.

\overline{CS} also puts the TSC2046 into power-down mode. When \overline{CS} goes high, the TSC2046 immediately goes into power-down mode and does not complete the current conversion. The internal reference, however, does not turn off with \overline{CS} going high. To turn the reference off, an additional write is required before \overline{CS} goes high ($PD1 = 0$).

When the TSC2046 first powers up, the device draws about 20 μ A of current until a control byte is written to it with $PD0 = 0$ to put it into power-down mode. This can be avoided if the TSC2046 is powered up with $\overline{CS} = 0$ and $DCLK = IOVDD$.

LAYOUT

The following layout suggestions provide the most optimum performance from the TSC2046. Many portable applications, however, have conflicting requirements concerning power, cost, size, and weight. In general, most portable devices have fairly clean power and grounds because most of the internal components are very low power. This situation means less bypassing for the converter power and less concern regarding grounding. Still, each situation is unique and the following suggestions should be reviewed carefully.

For optimum performance, care should be taken with the physical layout of the TSC2046 circuitry. The basic SAR architecture is sensitive to glitches or sudden changes on the power supply, reference, ground connections, and digital inputs that occur just prior to latching the output of the analog comparator. Therefore, during any single conversion for an n-bitSAR converter, there are n 'windows' in which large external transient voltages can easily affect the conversion result. Such glitches can originate from switching power supplies, nearby digital logic, and high-power devices. The degree of error in the digital output depends on the reference voltage, layout, and the exact timing of the external event. The error can change if the external event changes in time with respect to the DCLK input.

With this in mind, power to the TSC2046 should be clean and well bypassed. A 0.1 μ F ceramic bypass capacitor should be placed as close to the device as possible. A 1 μ F to 10 μ F capacitor may also be needed if the impedance of the connection between + V_{CC} or IOVDD and the power supplies is high. Low-leakage capacitors should be used to minimize

power dissipation through the bypass capacitors when the TSC2046 is in power-down mode.

A bypass capacitor is generally not needed on the V_{REF} pin because the internal reference is buffered by an internal op amp. If an external reference voltage originates from an op amp, make sure that it can drive any bypass capacitor that is used without oscillation.

The TSC2046 architecture offers no inherent rejection of noise or voltage variation in regards to using an external reference input. This is of particular concern when the reference input is tied to the power supply. Any noise and ripple from the supply appears directly in the digital results. Whereas high-frequency noise can be filtered out, voltage variation due to line frequency (50Hz or 60Hz) can be difficult to remove.

The GND pin must be connected to a clean ground point. In many cases, this is the analog ground. Avoid connections which are too near the grounding point of a microcontroller or digital signal processor. If needed, run a ground trace directly from the converter to the power-supply entry or battery-connection point. The ideal layout includes an analog ground plane dedicated to the converter and associated analog circuitry.

In the specific case of use with a resistive touch screen, care should be taken with the connection between the converter and the touch screen. Although resistive touch screens have fairly low resistance, the interconnection should be as short and robust as possible. Longer connections are a source of error, much like the on-resistance of the internal switches. Likewise, loose connections can be a source of error when the contact resistance changes with flexing or vibrations.

As indicated previously, noise can be a major source of error in touch screen applications (e.g., applications that require a backlit LCD panel). This EMI noise can be coupled through the LCD panel to the touch screen and cause "flickering" of the converted data. Several things can be done to reduce this error, such as using a touch screen with a bottom-side metal layer connected to ground to shunt the majority of noise to ground. Additionally, filtering capacitors from $Y+$, $Y-$, $X+$, and $X-$ pins to ground can also help. Caution should be observed under these circumstances for settling time of the touch screen, especially operating in the single-ended mode and at high data rates.

PACKAGING INFORMATION

Orderable Device	Status ⁽¹⁾	Package Type	Package Drawing	Pins	Package Qty	Eco Plan ⁽²⁾	Lead/Ball Finish	MSL Peak Temp ⁽³⁾
TSC2046EIPW	PREVIEW	TSSOP	PW	16	90	None	Call TI	Call TI
TSC2046EIPWR	PREVIEW	TSSOP	PW	16	2000	None	Call TI	Call TI
TSC2046EIZQCR	PREVIEW	BGA MI CROSTA R JUNI OR	ZQC	48	2500	None	Call TI	Call TI
TSC2046IGQCR	ACTIVE	VFBGA	GQC	48	2500	None	SNPB	Level-2A-235C-4 WKS
TSC2046IPW	ACTIVE	TSSOP	PW	16	100	None	CU NIPDAU	Level-2-220C-1 YEAR
TSC2046IPWR	ACTIVE	TSSOP	PW	16	2500	None	CU NIPDAU	Level-2-220C-1 YEAR
TSC2046IPWRG4	PREVIEW	TSSOP	PW	16		Green (RoHS & no Sb/Br)	CU NIPDAU	Level-1-260C-UNLIM
TSC2046IRGVR	ACTIVE	QFN	RGV	16	2500	None	CU NIPDAU	Level-1-235C-UNLIM
TSC2046IRGVRG4	ACTIVE	QFN	RGV	16	2500	Green (RoHS & no Sb/Br)	CU NIPDAU	Level-1-260C-UNLIM
TSC2046IRGVT	ACTIVE	QFN	RGV	16	250	None	CU NIPDAU	Level-1-235C-UNLIM
TSC2046IZQCR	ACTIVE	BGA MI CROSTA R JUNI OR	ZQC	48	2500	Pb-Free (RoHS)	SNAGCU	Level-3-260C-168 HR
TSC2046IZQCR-90	ACTIVE	BGA MI CROSTA R JUNI OR	ZQC	48	2500	Pb-Free (RoHS)	SNAGCU	Level-3-260C-168 HR

⁽¹⁾ The marketing status values are defined as follows:

ACTIVE: Product device recommended for new designs.

LIFEBUY: TI has announced that the device will be discontinued, and a lifetime-buy period is in effect.

NRND: Not recommended for new designs. Device is in production to support existing customers, but TI does not recommend using this part in a new design.

PREVIEW: Device has been announced but is not in production. Samples may or may not be available.

OBSELETE: TI has discontinued the production of the device.

⁽²⁾ Eco Plan - May not be currently available - please check <http://www.ti.com/productcontent> for the latest availability information and additional product content details.

None: Not yet available Lead (Pb-Free).

Pb-Free (RoHS): TI's terms "Lead-Free" or "Pb-Free" mean semiconductor products that are compatible with the current RoHS requirements for all 6 substances, including the requirement that lead not exceed 0.1% by weight in homogeneous materials. Where designed to be soldered at high temperatures, TI Pb-Free products are suitable for use in specified lead-free processes.

Green (RoHS & no Sb/Br): TI defines "Green" to mean "Pb-Free" and in addition, uses package materials that do not contain halogens, including bromine (Br) or antimony (Sb) above 0.1% of total product weight.

⁽³⁾ MSL, Peak Temp. -- The Moisture Sensitivity Level rating according to the JEDEC industry standard classifications, and peak solder temperature.

Important Information and Disclaimer: The information provided on this page represents TI's knowledge and belief as of the date that it is provided. TI bases its knowledge and belief on information provided by third parties, and makes no representation or warranty as to the accuracy of such information. Efforts are underway to better integrate information from third parties. TI has taken and continues to take reasonable steps to provide representative and accurate information but may not have conducted destructive testing or chemical analysis on incoming materials and chemicals. TI and TI suppliers consider certain information to be proprietary, and thus CAS numbers and other limited information may not be available for release.

In no event shall TI's liability arising out of such information exceed the total purchase price of the TI part(s) at issue in this document sold by TI to Customer on an annual basis.

ZQC (S-PBGA-N48)

PLASTIC BALL GRID ARRAY

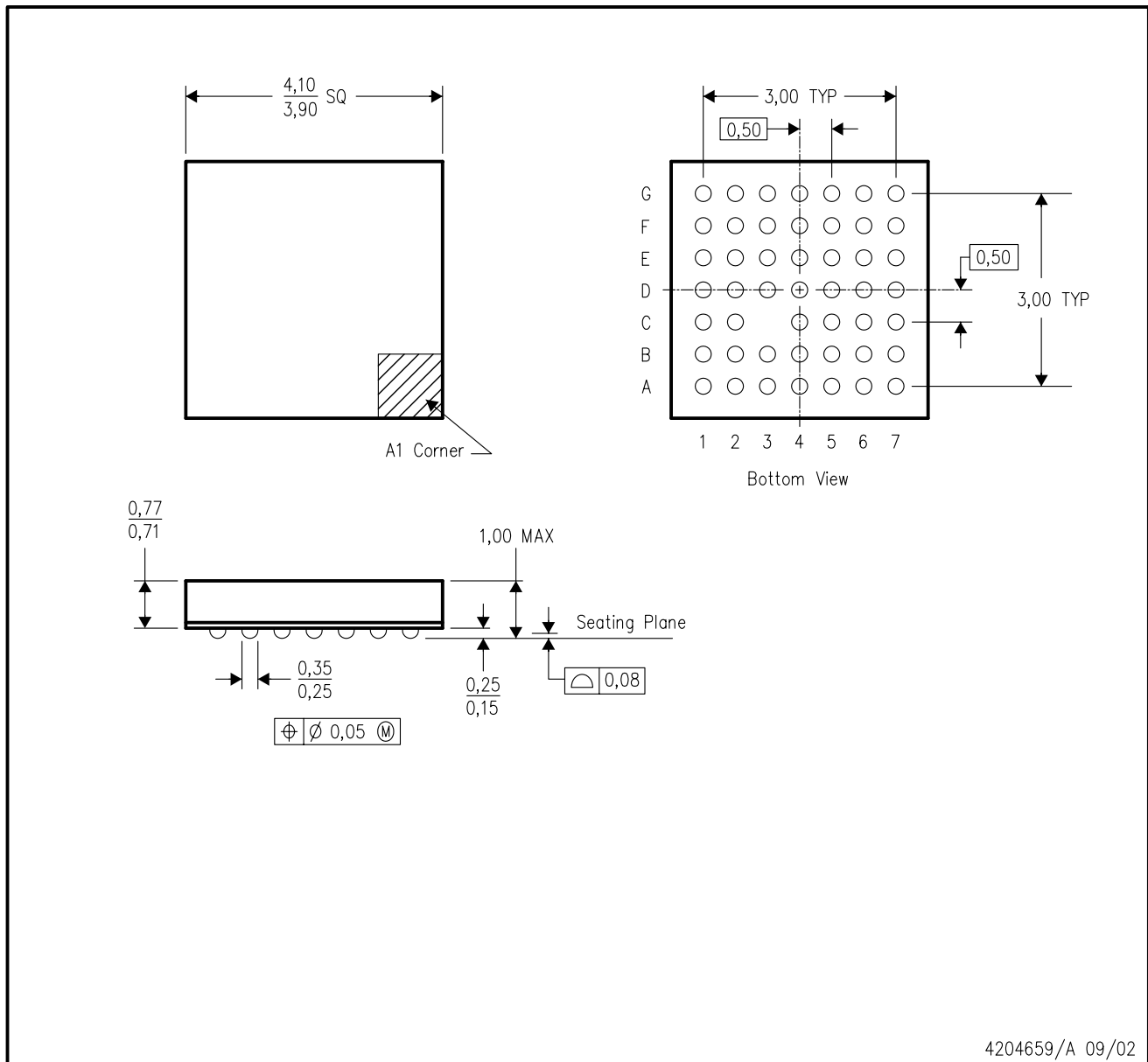

- NOTES:
- A. All linear dimensions are in millimeters.
 - B. This drawing is subject to change without notice.
 - C. MicroStar Junior™ BGA configuration
 - D. Falls within JEDEC MO-225
 - E. This package is lead-free.

MicroStar Junior is a trademark of Texas Instruments.

GQC (S-PBGA-N48)

PLASTIC BALL GRID ARRAY

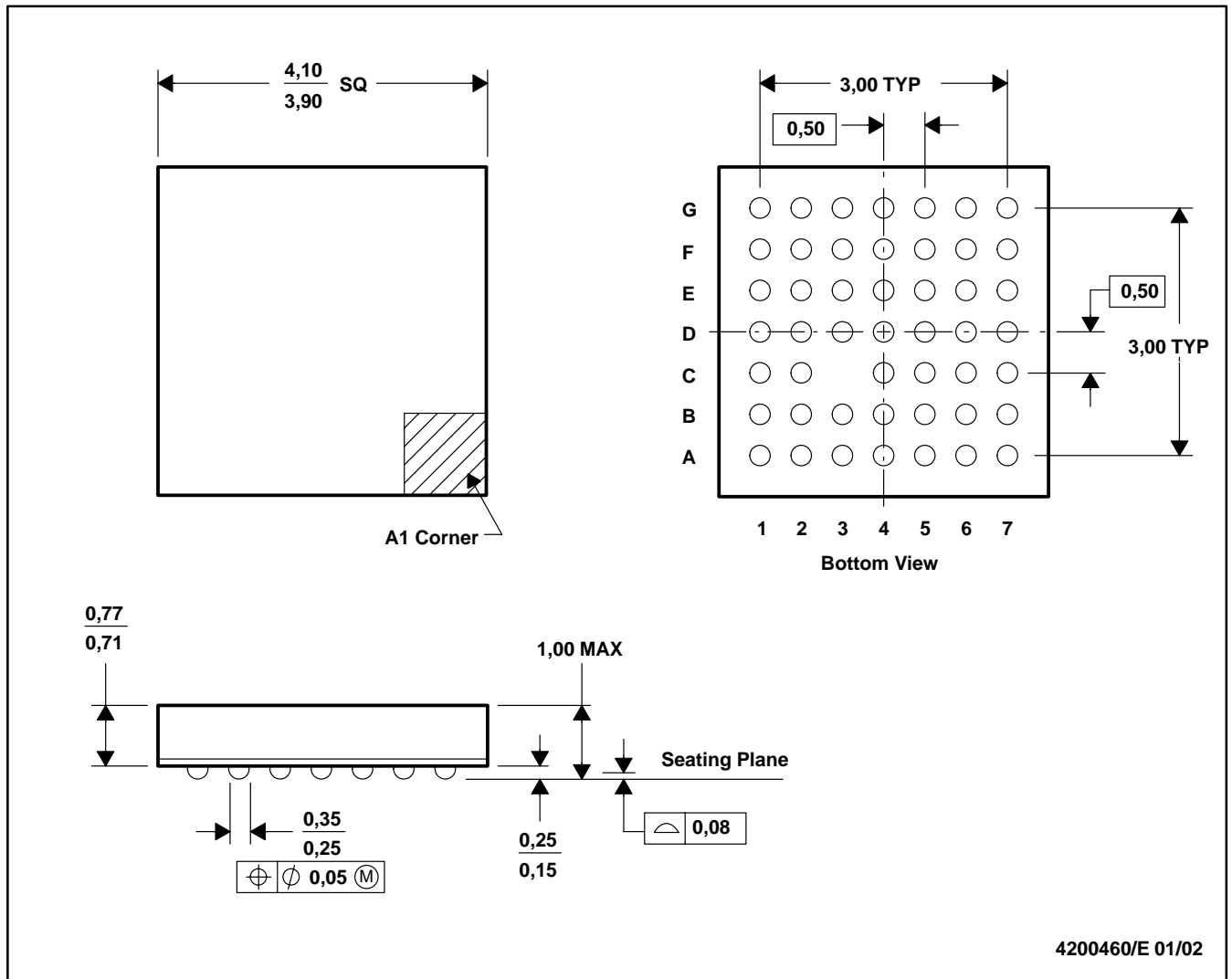

- NOTES: A. All linear dimensions are in millimeters.
 B. This drawing is subject to change without notice.
 C. MicroStar Junior™ BGA configuration
 D. Falls within JEDEC MO-225

MicroStar Junior is a trademark of Texas Instruments.

RGV (S-PQFP-N16)

PLASTIC QUAD FLATPACK

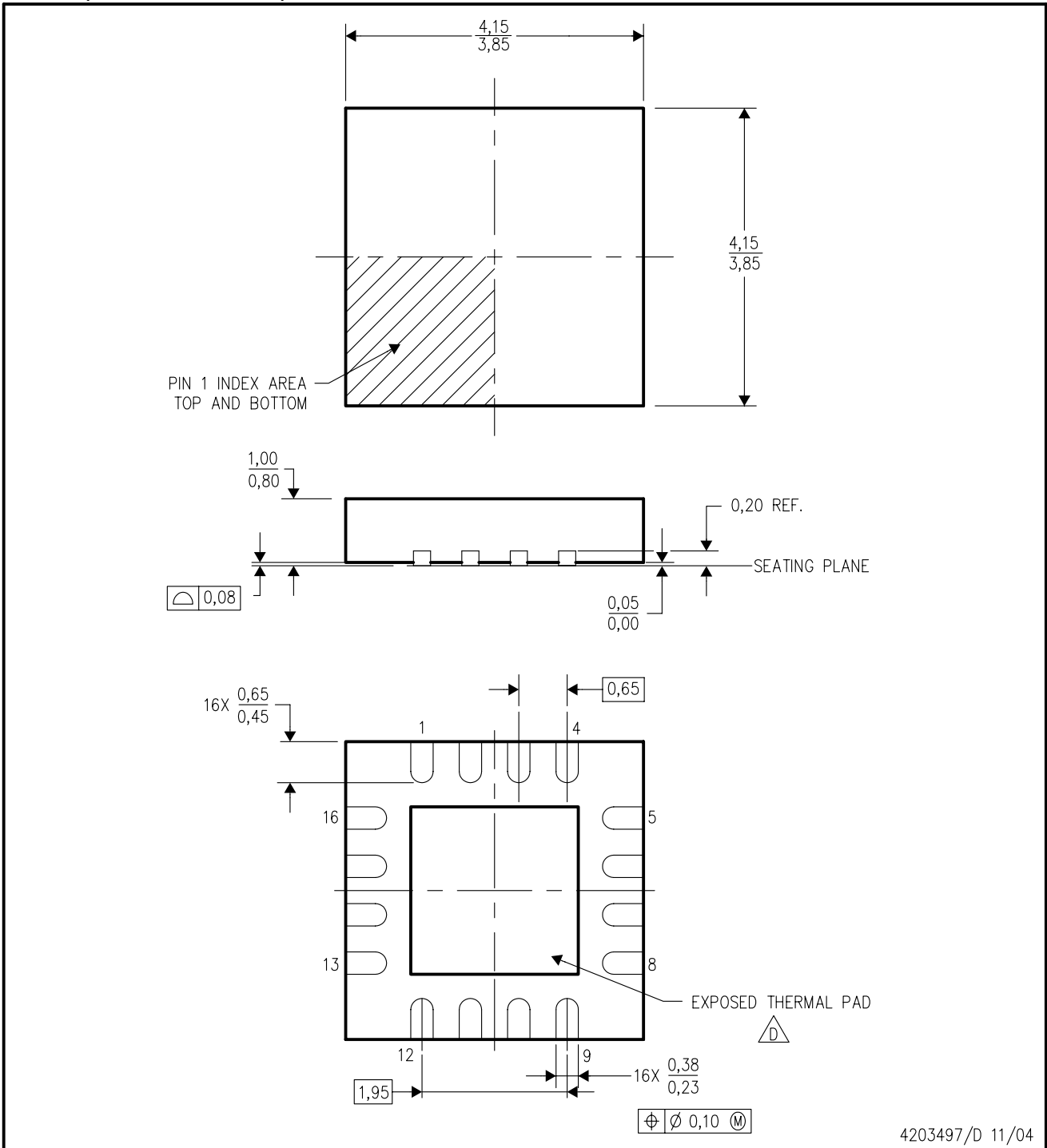

4203497/D 11/04

- NOTES:
- All linear dimensions are in millimeters. Dimensioning and tolerancing per ASME Y14.5M-1994.
 - This drawing is subject to change without notice.
 - Quad Flatpack, No-leads (QFN) package configuration.
 - $\triangle D$ The package thermal pad must be soldered to the board for thermal and mechanical performance. See the Product Data Sheet for details regarding the exposed thermal pad dimensions.
 - Falls within JEDEC MO-220.

PW (R-PDSO-G**)

PLASTIC SMALL-OUTLINE PACKAGE

14 PINS SHOWN



4040064/F 01/97

- NOTES: A. All linear dimensions are in millimeters.
 B. This drawing is subject to change without notice.
 C. Body dimensions do not include mold flash or protrusion not to exceed 0,15.
 D. Falls within JEDEC MO-153

IMPORTANT NOTICE

Texas Instruments Incorporated and its subsidiaries (TI) reserve the right to make corrections, modifications, enhancements, improvements, and other changes to its products and services at any time and to discontinue any product or service without notice. Customers should obtain the latest relevant information before placing orders and should verify that such information is current and complete. All products are sold subject to TI's terms and conditions of sale supplied at the time of order acknowledgment.

TI warrants performance of its hardware products to the specifications applicable at the time of sale in accordance with TI's standard warranty. Testing and other quality control techniques are used to the extent TI deems necessary to support this warranty. Except where mandated by government requirements, testing of all parameters of each product is not necessarily performed.

TI assumes no liability for applications assistance or customer product design. Customers are responsible for their products and applications using TI components. To minimize the risks associated with customer products and applications, customers should provide adequate design and operating safeguards.

TI does not warrant or represent that any license, either express or implied, is granted under any TI patent right, copyright, mask work right, or other TI intellectual property right relating to any combination, machine, or process in which TI products or services are used. Information published by TI regarding third-party products or services does not constitute a license from TI to use such products or services or a warranty or endorsement thereof. Use of such information may require a license from a third party under the patents or other intellectual property of the third party, or a license from TI under the patents or other intellectual property of TI.

Reproduction of information in TI data books or data sheets is permissible only if reproduction is without alteration and is accompanied by all associated warranties, conditions, limitations, and notices. Reproduction of this information with alteration is an unfair and deceptive business practice. TI is not responsible or liable for such altered documentation.

Resale of TI products or services with statements different from or beyond the parameters stated by TI for that product or service voids all express and any implied warranties for the associated TI product or service and is an unfair and deceptive business practice. TI is not responsible or liable for any such statements.

Following are URLs where you can obtain information on other Texas Instruments products and application solutions:

Products		Applications	
Amplifiers	amplifier.ti.com	Audio	www.ti.com/audio
Data Converters	dataconverter.ti.com	Automotive	www.ti.com/automotive
DSP	dsp.ti.com	Broadband	www.ti.com/broadband
Interface	interface.ti.com	Digital Control	www.ti.com/digitalcontrol
Logic	logic.ti.com	Military	www.ti.com/military
Power Mgmt	power.ti.com	Optical Networking	www.ti.com/opticalnetwork
Microcontrollers	microcontroller.ti.com	Security	www.ti.com/security
		Telephony	www.ti.com/telephony
		Video & Imaging	www.ti.com/video
		Wireless	www.ti.com/wireless

Mailing Address: Texas Instruments
Post Office Box 655303 Dallas, Texas 75265