



TS831

MICROPOWER VOLTAGE SUPERVISOR RESET ACTIVE LOW

- ULTRA LOW POWER CONSUMPTION :
12µA maximum
- PRECISION RESET THRESHOLD
- THRESHOLD VOLTAGE:
4.33V typ. FOR TS831-5
4.50V typ. FOR TS831-4
2.71V typ. FOR TS831-3
- GUARANTEED RESET OPERATION FOR
V_{CC} DOWN TO 1V
- OPEN DRAIN OUTPUT COMPARATOR
- FAST RESPONSE TIME : 20µs FOR A 10mV
OVERDRIVE
- INTERNAL BUILT-IN HYSTERESIS
- PIN TO PIN COMPATIBLE WITH MC33064
AND MC33164

DESCRIPTION

The TS831 ultra low power integrated circuit incorporates a high stability band-gap voltage reference and a comparator with open drain output. The threshold voltage is set at 4.33V for TS831-5, 4.5V for TS831-4 and 2.71V for TS831-3 by internal thermally matched resistances.

The comparator exhibits a 20µs response (with 10mV overdrive) and has an open drain output active when input voltage is lower than the threshold. An internal hysteresis, 100mV for TS831-4/TS831-5 and 60mV for TS831-3, increases the comparator's noise margin and prevents false reset operation.

APPLICATION

- Power-on reset generator for microcontroller
- Power failure detector

ORDER CODE

Part Number	Temperature Range	Package		
		D	Z	P
TS831-5I	-40, +125°C	•	•	•
TS831-4I		•	•	•
TS831-3I		•	•	•

Z= TO92 Plastic package

D = Small Outline Package (SO) - also available in Tape & Reel (DT)
P = Thin Shrink Small Outline Package (TSSOP) - only available
in Tape & Reel (PT)

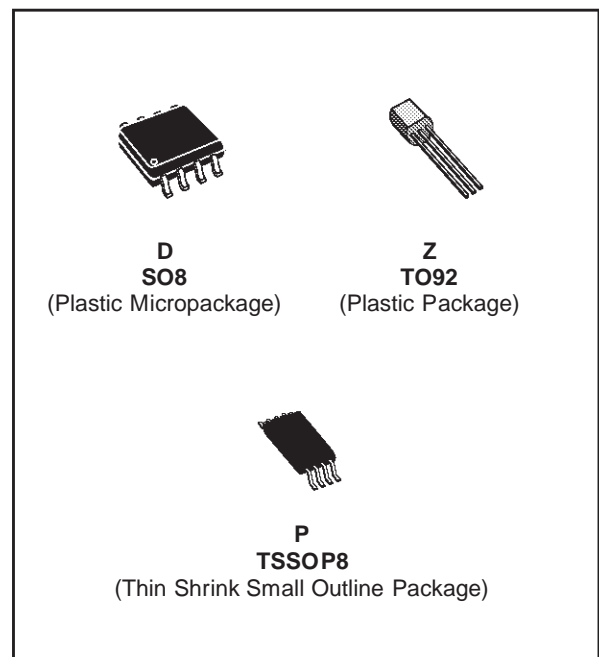

PIN CONNECTIONS (top view)

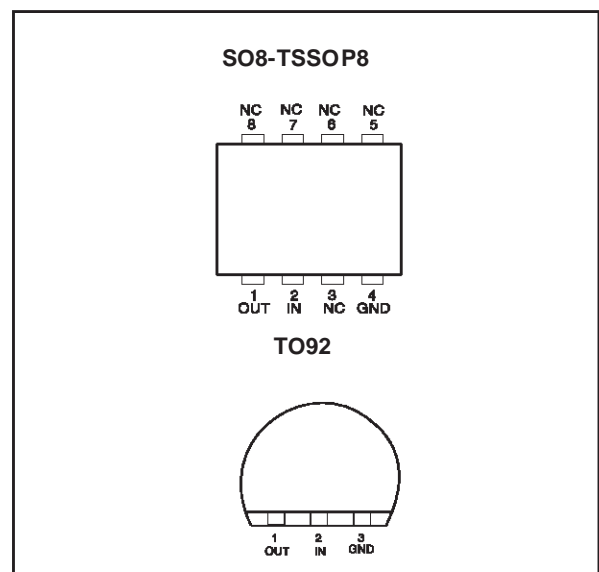

ABSOLUTE MAXIMUM RATINGS

Symbol	Parameter	Value	Unit
V_{CC}	Supply Voltage ¹⁾	7	V
V_{out}	Output Voltage	-0.3 to $V_{CC} + 0.3$	V
I_{out}	Output Sink Current TS831-5 and TS831-4 TS831-3	20 5	mA
P_d	Power Dissipation ²⁾ TO92 SO8 TSSOP8	625 700 625	mW
I_F	Clamp Diode Forward Current, pin 1 to pin 2 ³⁾	100	mA
T_{oper}	Operating Free Air Temperature Range	-40 to +85	°C
T_{stg}	Storage Temperature	-65 to +150	°C

1. All voltages values, except differential voltage are with respect to network ground terminal.

2. $T_j = 150^\circ\text{C}$, $T_{amb} = 25^\circ\text{C}$ with $R_{thja} = 200^\circ\text{C/W}$ for TO-92 package
 $R_{thja} = 175^\circ\text{C/W}$ for SO8 package
 $R_{thja} = 200^\circ\text{C/W}$ for TSSOP8 package

3. Maximum package power dissipation limits must be observed.

OPERATING CONDITIONS

Symbol	Parameter	Value	Unit
V_{CC}	Supply Voltage	1 to 5.5	V

TS831-5

ELECTRICAL CHARACTERISTICS $T_{amb} = 25^\circ\text{C}$ (unless otherwise specified)

Symbol	Parameter	Min.	Typ.	Max.	Unit
V_{thi}	Threshold Voltage - V_{CC} Increasing -40°C ≤ T_{amb} ≤ +85°C -40°C ≤ T_{amb} ≤ +125°C	4.10 4.10	4.33	4.46 4.50	V
V_{thd}	Threshold Voltage - V_{CC} Decreasing -40°C ≤ T_{amb} ≤ +85°C -40°C ≤ T_{amb} ≤ +125°C	4.10 4.06	4.21	4.46 4.46	V
V_{hys}	Hysteresis Voltage	50	100	200	mV
I_{CC}	Current Consumption $V_{CC} = 5V$			12	μA
V_{OL}	Low Level Output Voltage -40°C ≤ T_{amb} ≤ +85°C -40°C ≤ T_{amb} ≤ +125°C $V_{CC} = 4V$, $I_{OL} = 8mA$		450	800 1000 1300	mV
I_{OH}	Low Level Output Voltage -40°C ≤ T_{amb} ≤ +125°C $V_{CC} = 5V$		2	100 1000	nA
tphl	Response Time High to Low $R_L = 10k\Omega$, $C_L = 15pF$, $V_{CC} = V_{thd} - 10mV$		20		μs

Note : Limits are 100% production tested at 25°C. Limits over temperature are guaranteed through correlation and by design.

TS831

TS831-4

ELECTRICAL CHARACTERISTICS Tamb = 25°C (unless otherwise specified)

Symbol	Parameter	Min.	Typ.	Max.	Unit
V_{thi}	Threshold Voltage - V_{CC} Increasing -40°C ≤ Tamb ≤ +85°C -40°C ≤ Tamb ≤ +125°C	4.17 4.10	4.50	4.66 4.70	V
V_{thd}	Threshold Voltage - V_{CC} Decreasing -40°C ≤ Tamb ≤ +85°C -40°C ≤ Tamb ≤ +125°C	4.17 4.13	4.40	4.66 4.66	V
V_{hys}	Hysteresis Voltage	50	100	200	mV
I_{CC}	Current Consumption $V_{CC} = 5V$			12	μA
V_{OL}	Low Level Output Voltage -40°C ≤ Tamb ≤ +85°C -40°C ≤ Tamb ≤ +125°C $V_{CC} = 4V, I_{OL} = 8mA$		450	800 1000 1300	mV
I_{OH}	Low Level Output Voltage -40°C ≤ Tamb ≤ +125°C $V_{CC} = 5V$		2	100 1000	nA
tphl	Response Time High to Low $R_L = 10k\Omega, C_L = 15pF, V_{CC} = V_{thd} - 10mV$		20		μs

Note : Limits are 100% production tested at 25°C. Limits over temperature are guaranteed through correlation and by design.

TS831-3

ELECTRICAL CHARACTERISTICS Tamb = 25°C (unless otherwise specified)

Symbol	Parameter	Min.	Typ.	Max.	Unit
V_{thi}	Threshold Voltage - V_{CC} Increasing -40°C ≤ Tamb ≤ +125°C	2.55	2.71	2.8	V
V_{thd}	Threshold Voltage - V_{CC} Decreasing -40°C ≤ Tamb ≤ +125°C	2.55	2.65	2.8	V
V_{hys}	Hysteresis Voltage	30	60	100	mV
I_{CC}	Current Consumption $V_{CC} = 3V$			12	μA
V_{OL}	Low Level Output Voltage -40°C ≤ Tamb ≤ +125°C $V_{CC} = 2.4V, I_{OL} = 1mA$		140	400 500	mV
I_{OH}	Low Level Output Voltage -40°C ≤ Tamb ≤ +125°C $V_{CC} = 3V$		2	100 1000	nA
tphl	Response Time High to Low $R_L = 10k\Omega, C_L = 15pF, V_{CC} = V_{thd} - 10mV$		20		μs

Note : Limits are 100% production tested at 25°C. Limits over temperature are guaranteed through correlation and by design.

EQUIVALENT SCHEMATIC DIAGRAM

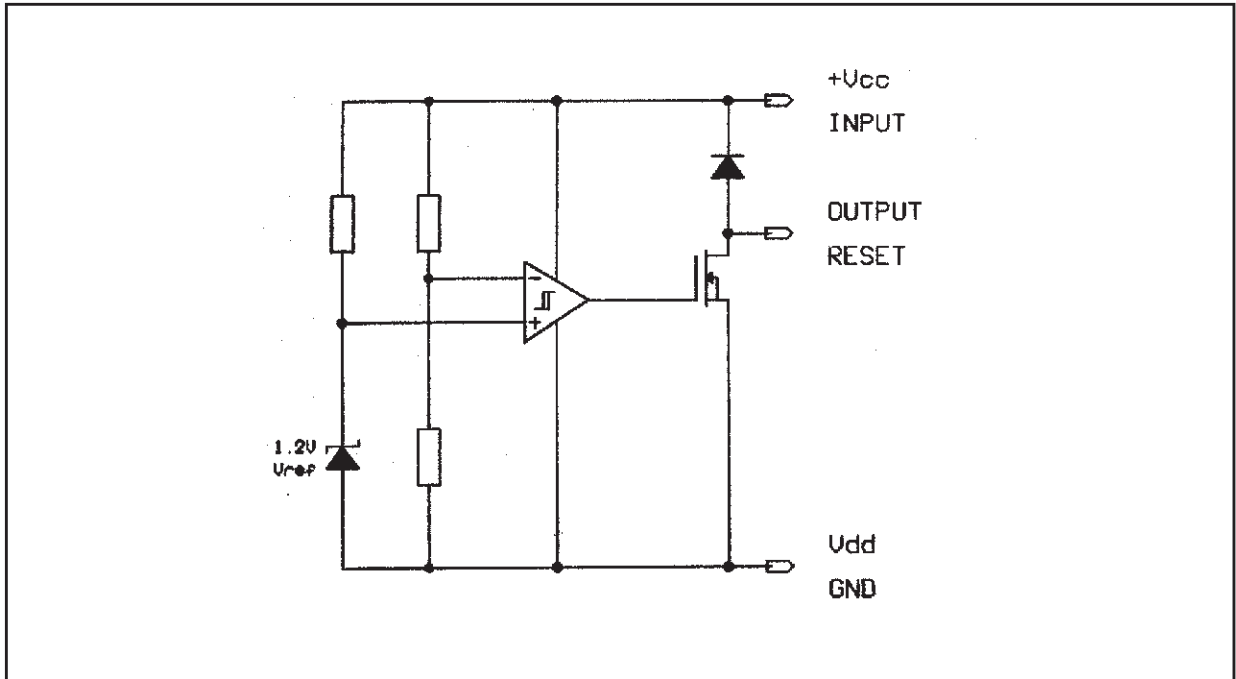

TIMING DIAGRAM

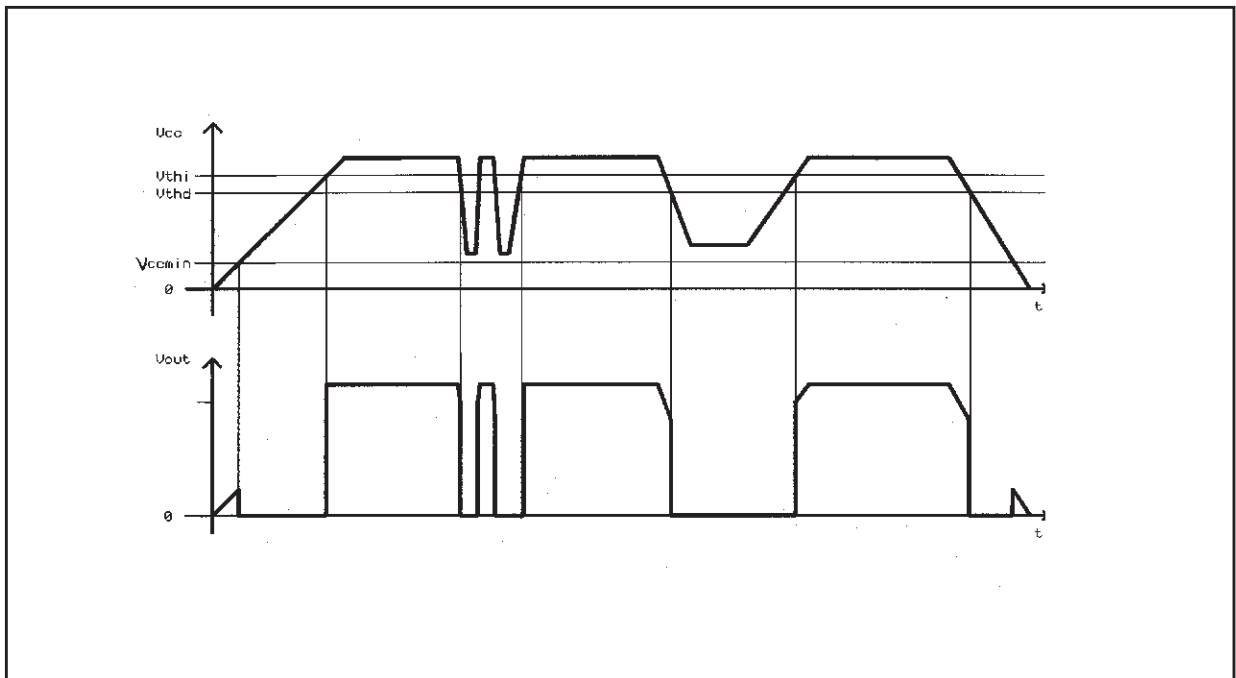

Output voltage versus input voltage

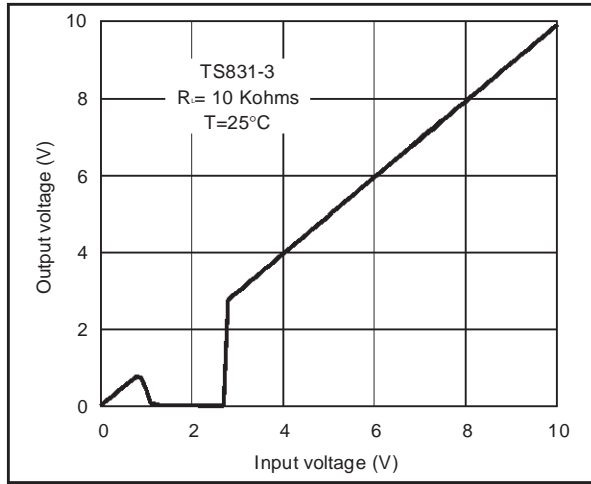

Reset output voltage versus Input voltage

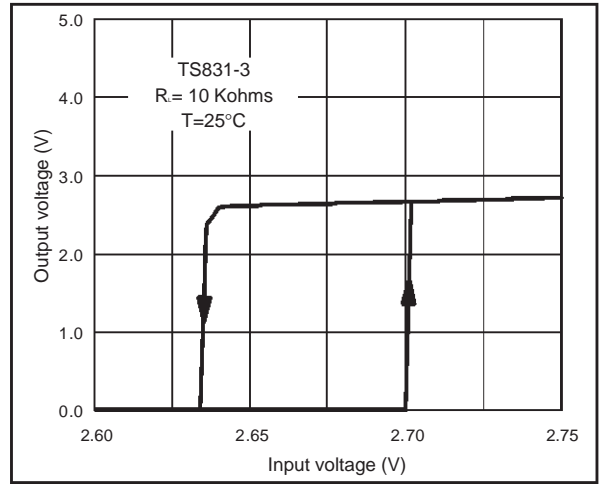

Output voltage versus input voltage

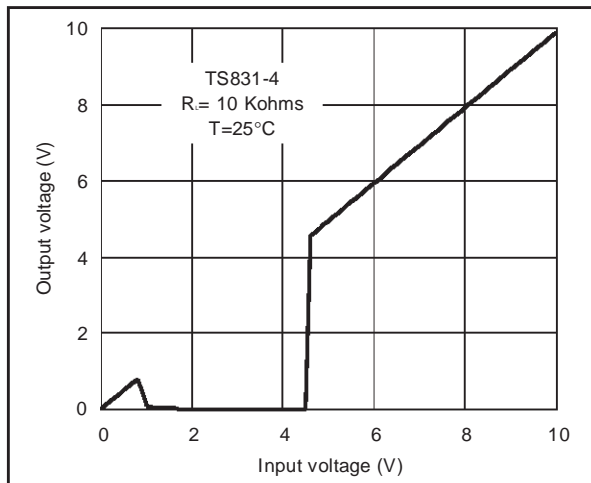

Reset output voltage versus Input voltage

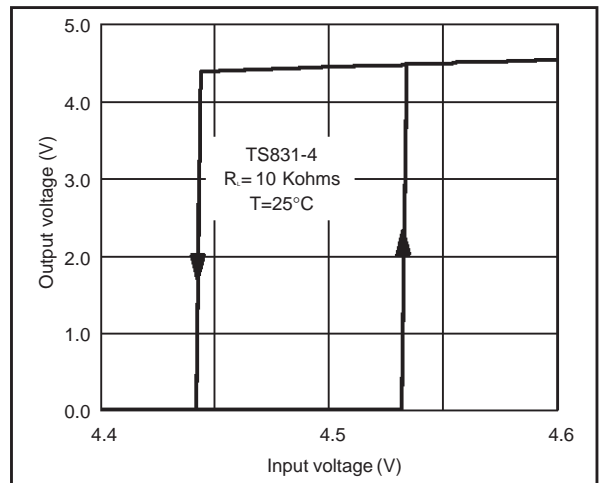

Output voltage versus input voltage

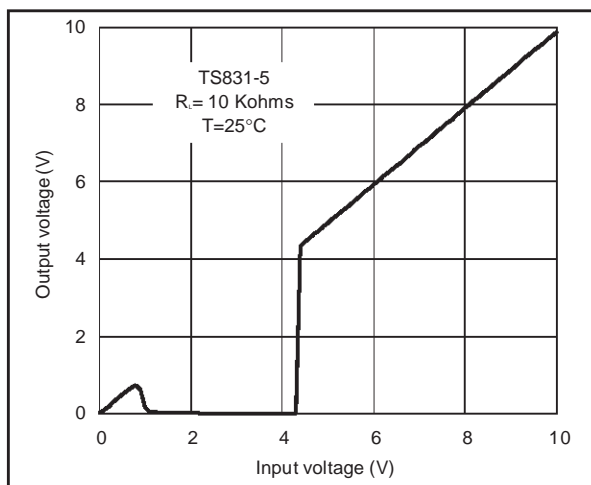

Reset output voltage versus Input voltage

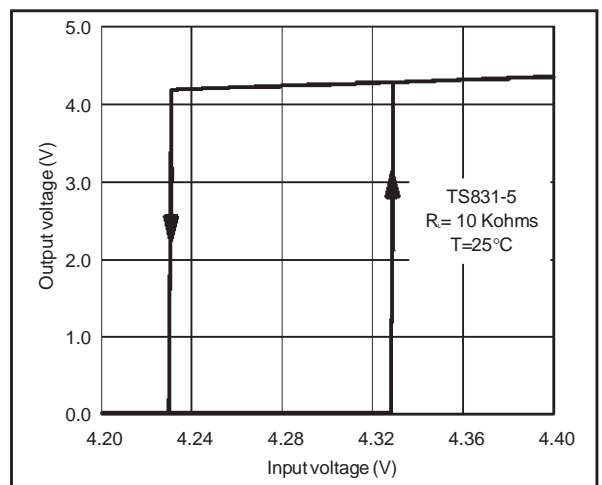

Vth versus temperature while Vcc increasing

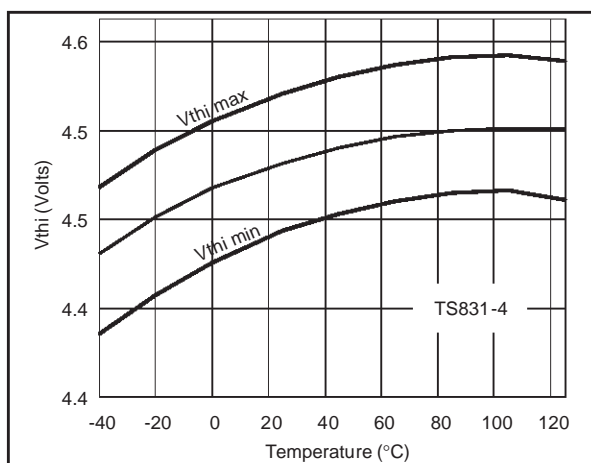

Vth versus temperature while Vcc decreasing

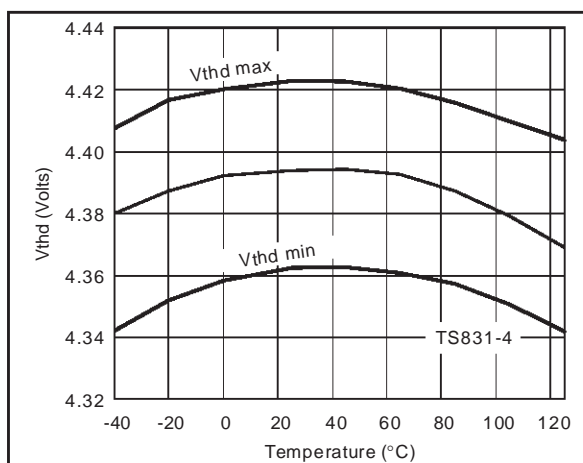

Hysteresis voltage versus temperature

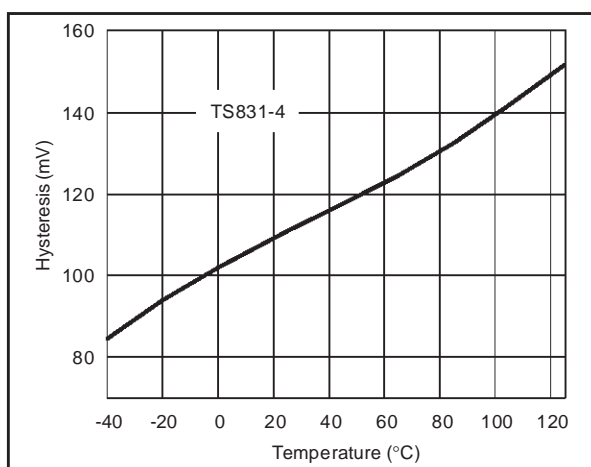

Supply current versus temperature

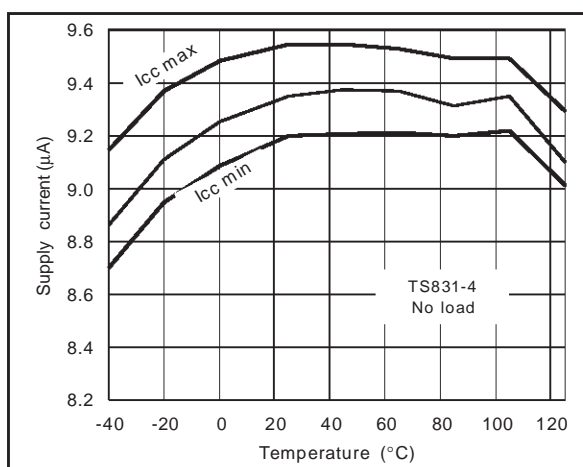

Supply current vs input voltage & temperature

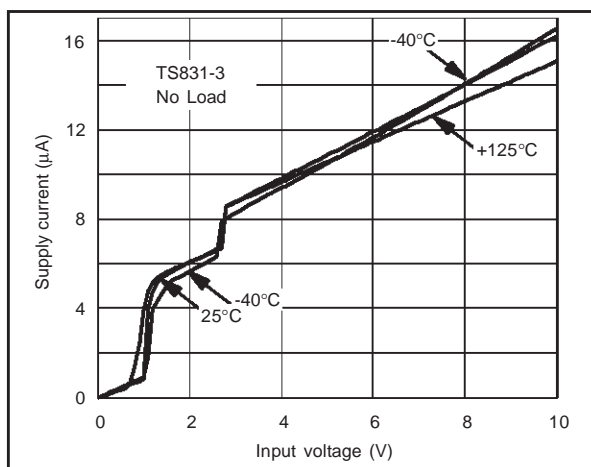

Voltage output low vs Isink & temperature

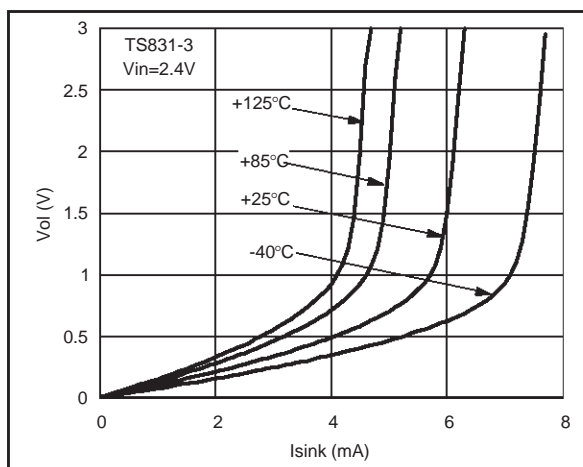

TS831

Supply current vs input voltage & temperature

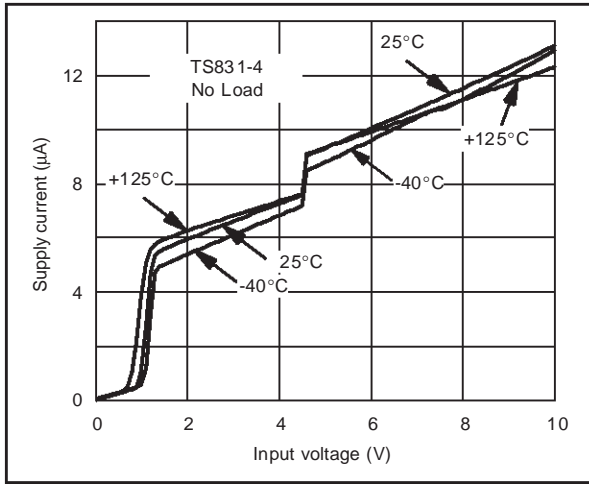

Voltage output low vs Isink & temperature

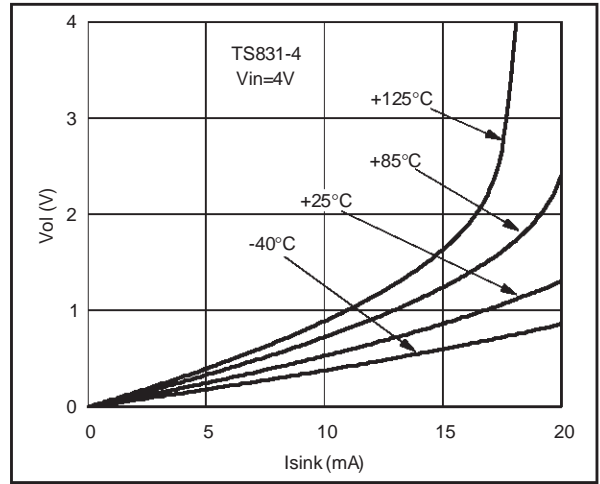

Supply current vs input voltage & temperature

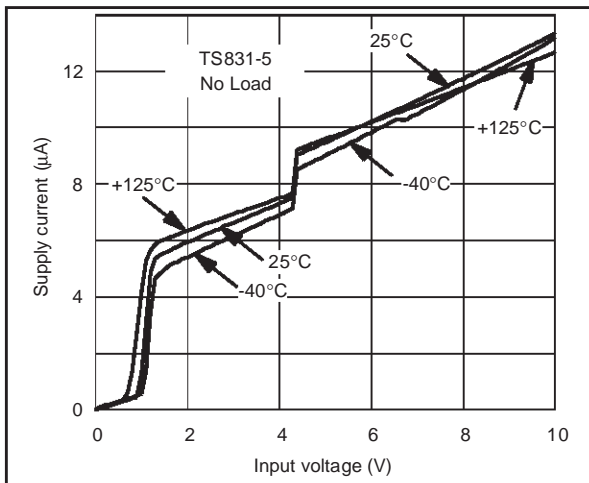

Voltage output low vs Isink & temperature

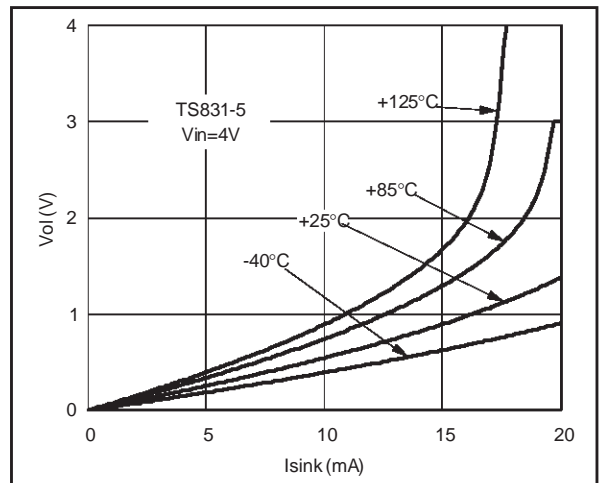

Clamp diode forward current versus voltage

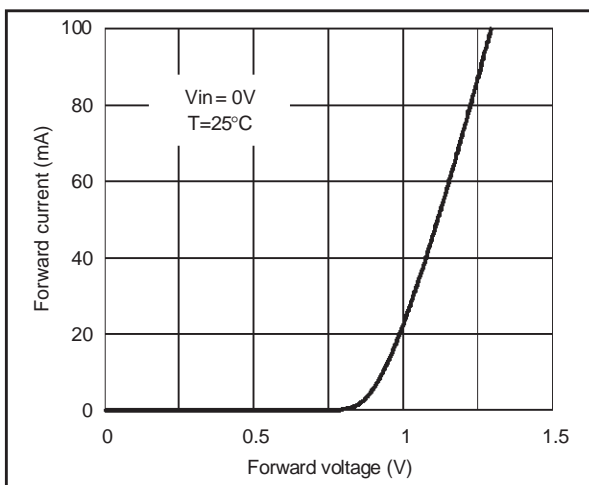

Response time

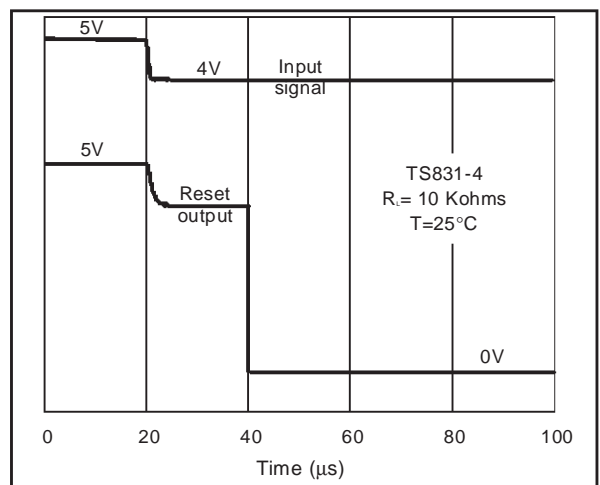

Basic configuration

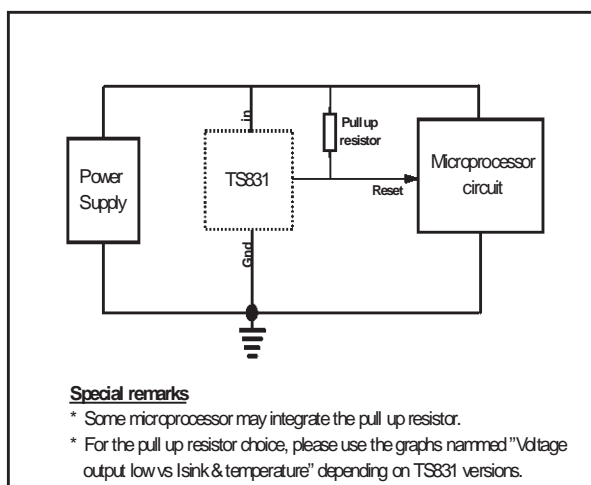

TS831

PACKAGE MECHANICAL DATA
8 PINS - PLASTIC MICROPACKAGE (SO)

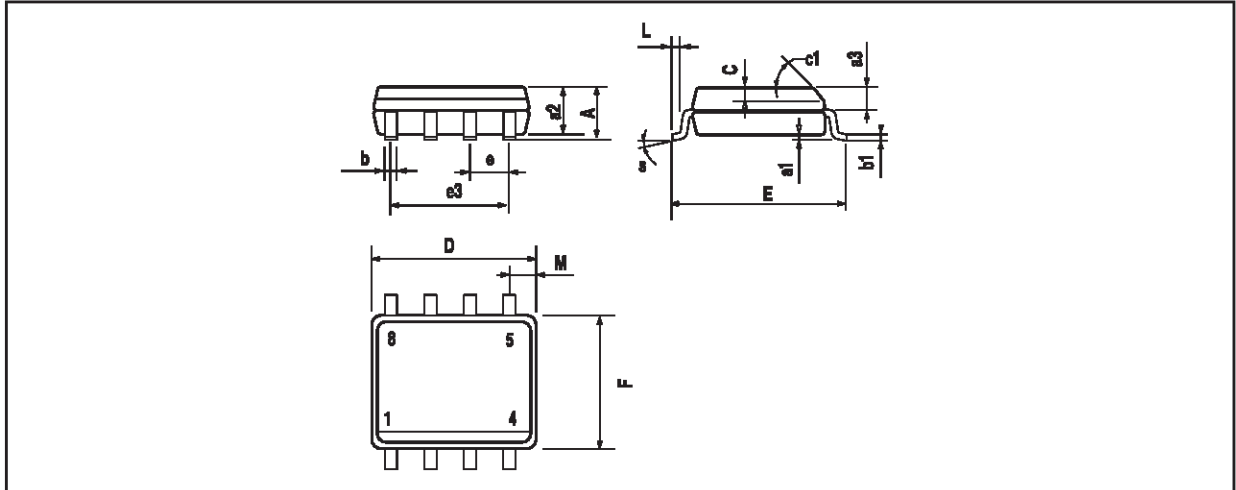

Dim.	Millimeters			Inches		
	Min.	Typ.	Max.	Min.	Typ.	Max.
A			1.75			0.069
a1	0.1		0.25	0.004		0.010
a2			1.65			0.065
a3	0.65		0.85	0.026		0.033
b	0.35		0.48	0.014		0.019
b1	0.19		0.25	0.007		0.010
C	0.25		0.5	0.010		0.020
c1	45° (typ.)					
D	4.8		5.0	0.189		0.197
E	5.8		6.2	0.228		0.244
e		1.27			0.050	
e3		3.81			0.150	
F	3.8		4.0	0.150		0.157
L	0.4		1.27	0.016		0.050
M			0.6			0.024
S	8° (max.)					

PACKAGE MECHANICAL DATA
3 PINS - PLASTIC PACKAGE TO92

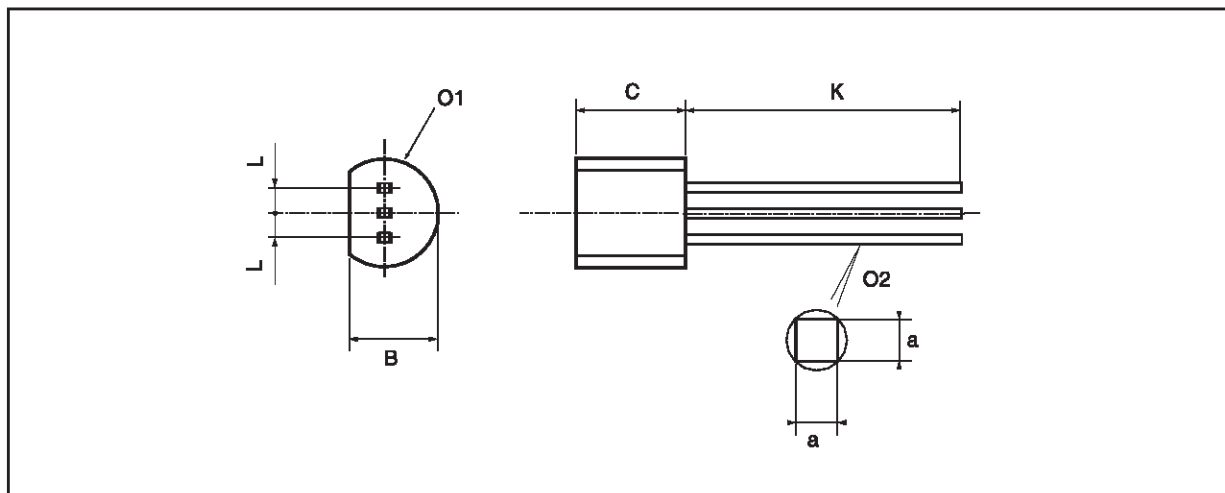

Dim.	Millimeters			Inches		
	Min	Typ.	Max.	Min.	Typ.	Max.
L		1.27			0.05	
B	3.2	3.7	4.2	0.126	0.1457	0.1654
O1	4.45	5.00	5.2	0.1752	0.1969	0.2047
C	4.58	5.03	5.33	0.1803	0.198	0.2098
K	12.7			0.5		
O2	0.407	0.5	0.508	0.016	0.0197	0.02
a	0.35			0.0138		

PACKAGE MECHANICAL DATA
8 PINS - THIN SHRINK SMALL OUTLINE PACKAGE

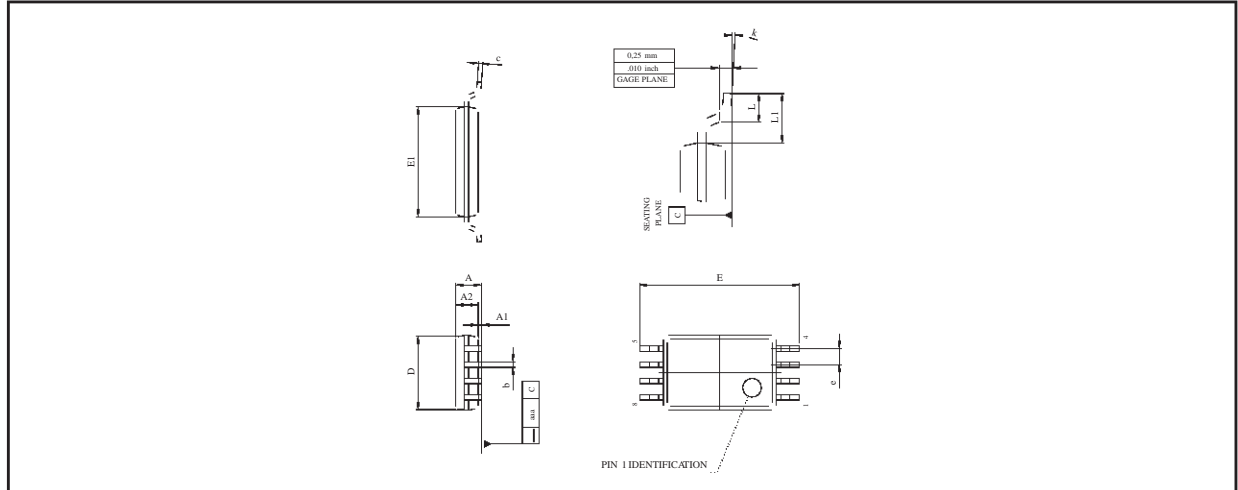

Dim.	Millimeters			Inches		
	Min.	Typ.	Max.	Min.	Typ.	Max.
A			1.20			0.05
A1	0.05		0.15	0.01		0.006
A2	0.80	1.00	1.05	0.031	0.039	0.041
b	0.19		0.30	0.007		0.15
c	0.09		0.20	0.003		0.012
D	2.90	3.00	3.10	0.114	0.118	0.122
E		6.40			0.252	
E1	4.30	4.40	4.50	0.169	0.173	0.177
e		0.65			0.025	
k	0°		8°	0°		8°
l	0.50	0.60	0.75	0.09	0.0236	0.030

Information furnished is believed to be accurate and reliable. However, STMicroelectronics assumes no responsibility for the consequences of use of such information nor for any infringement of patents or other rights of third parties which may result from its use. No license is granted by implication or otherwise under any patent or patent rights of STMicroelectronics. Specifications mentioned in this publication are subject to change without notice. This publication supersedes and replaces all information previously supplied. STMicroelectronics products are not authorized for use as critical components in life support devices or systems without express written approval of STMicroelectronics.

© The ST logo is a registered trademark of STMicroelectronics

© 2000 STMicroelectronics - Printed in Italy - All Rights Reserved
STMicroelectronics GROUP OF COMPANIES

Australia - Brazil - China - Finland - France - Germany - Hong Kong - India - Italy - Japan - Malaysia - Malta - Morocco
 Singapore - Spain - Sweden - Switzerland - United Kingdom

© <http://www.st.com>

