

QUAD SPDT WIDE-BANDWIDTH VIDEO SWITCH WITH LOW ON-STATE RESISTANCE

FEATURES

- **Low Differential Gain and Phase**
($D_G = 0.64\%$, $D_P = 0.1$ Degrees Typ)
- **Wide Bandwidth** (BW = 300 MHz Min)
- **Low Crosstalk** ($X_{TALK} = -63$ dB Typ)
- **Low Power Consumption**
($I_{CC} = 3 \mu\text{A Max}$)
- **Bidirectional Data Flow With Near-Zero Propagation Delay**
- **Low ON-State Resistance** ($r_{on} = 3 \Omega$ Typ)
- **V_{CC} Operating Range From 4.5 V to 5.5 V**
- **I_{off} Supports Partial-Power-Down Mode Operation**
- **Data and Control Inputs Provide Undershoot Clamp Diode**
- **Control Inputs Can Be Driven by TTL or 5-V/3.3-V CMOS Outputs**
- **Latch-Up Performance Exceeds 100 mA Per JESD 78, Class II**
- **ESD Performance Tested Per JESD 22**
– 1000-V Charged-Device Model (C101)
- **Suitable for Both RGB and Composite-Video Switching**

D, DBQ, OR PW PACKAGE
(TOP VIEW)

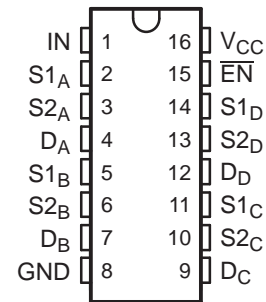

RGY PACKAGE
(TOP VIEW)

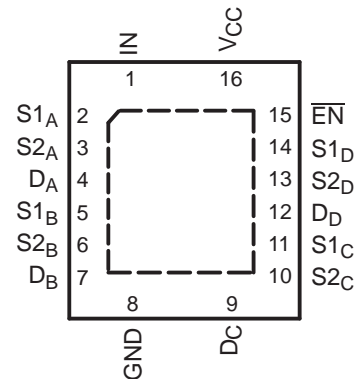

DESCRIPTION/ORDERING INFORMATION

The TS5V330 video switch is a 4-bit 1-of-2 multiplexer/demultiplexer with a single switch-enable (\overline{EN}) input. When \overline{EN} is low, the switch is enabled and the D port is connected to the S port. When \overline{EN} is high, the switch is disabled and the high-impedance state exists between the D and S ports. The select (IN) input controls the data path of the multiplexer/demultiplexer.

Low differential gain and phase make this switch ideal for composite and RGB video applications. This device has wide bandwidth and low crosstalk, making it suitable for high-frequency applications as well.

This device is fully specified for partial-power-down applications using I_{off} . The I_{off} feature ensures that damaging current will not backflow through the device when it is powered down. This switch maintains isolation during power off.



Please be aware that an important notice concerning availability, standard warranty, and use in critical applications of Texas Instruments semiconductor products and disclaimers thereto appears at the end of this data sheet.

ORDERING INFORMATION

T_A	PACKAGE ⁽¹⁾		ORDERABLE PART NUMBER	TOP-SIDE MARKING
–40°C to 85°C	QFN – RGY	Tape and reel	TS5V330RGYR	TE330
	SOIC – D	Tube	TS5V330D	TS5V330
		Tape and reel	TS5V330DR	
	SSOP (QSOP) – DBQ	Tape and reel	TS5V330DBQR	TE330
	TSSOP – PW	Tube	TS5V330PW	TE330
		Tape and reel	TS5V330PWR	

(1) Package drawings, standard packing quantities, thermal data, symbolization, and PCB design guidelines are available at www.ti.com/sc/package.

DESCRIPTION/ORDERING INFORMATION (CONTINUED)

To ensure the high-impedance state during power up or power down, \overline{EN} should be tied to V_{CC} through a pullup resistor; the minimum value of the resistor is determined by the current-sinking capability of the driver.

FUNCTION TABLE

INPUTS		INPUT/OUTPUT D	FUNCTION
\overline{EN}	IN		
L	L	S1	D port = S1 port
L	H	S2	D port = S2 port
H	X	Z	Disconnect

PIN DESCRIPTION

PIN	DESCRIPTION
S1, S2	Analog video I/Os
D	Analog video I/Os
IN	Select input
\overline{EN}	Switch-enable input

PARAMETER DEFINITIONS

PARAMETER	DESCRIPTION
r_{on}	Resistance between the D and S ports, with the switch in the ON state
I_{OZ}	Output leakage current measured at the D and S ports, with the switch in the OFF state
I_{OS}	Short-circuit current measured at the I/O pins
V_{IN}	Voltage at IN
V_{EN}	Voltage at \overline{EN}
C_{IN}	Capacitance at the control (\overline{EN} , IN) inputs
C_{OFF}	Capacitance at the analog I/O port when the switch is OFF
C_{ON}	Capacitance at the analog I/O port when the switch is ON
V_{IH}	Minimum input voltage for logic high for the control (\overline{EN} , IN) inputs
V_{IL}	Minimum input voltage for logic low for the control (\overline{EN} , IN) inputs
V_{hys}	Hysteresis voltage at the control (\overline{EN} , IN) inputs
V_{IK}	I/O and control (\overline{EN} , IN) inputs diode clamp voltage
V_I	Voltage applied to the D or S pins when D or S is the switch input
V_O	Voltage applied to the D or S pins when D or S is the switch output
I_{IH}	Input high leakage current of the control (\overline{EN} , IN) inputs
I_{IL}	Input low leakage current of the control (\overline{EN} , IN) inputs
I_I	Current into the D or S pins when D or S is the switch input
I_O	Current into the D or S pins when D or S is the switch output
I_{off}	Output leakage current measured at the D or S ports, with $V_{CC} = 0$
t_{ON}	Propagation delay measured between 50% of the digital input to 90% of the analog output when switch is turned ON
t_{OFF}	Propagation delay measured between 50% of the digital input to 90% of the analog output when switch is turned OFF
BW	Frequency response of the switch in the ON state measured at –3 dB
X_{TALK}	Unwanted signal coupled from channel to channel. Measured in –dB. $X_{TALK} = 20 \log V_O/V_I$. This is a nonadjacent crosstalk.
O_{IRR}	Off isolation is the resistance (measured in –dB) between the input and output with the switch OFF.
D_G	Magnitude variation between analog input and output pins when the switch is ON and the dc offset of composite-video signal varies at the analog input pin. In the NTSC standard, the frequency of the video signal is 3.58 MHz, and dc offset is from 0 to 0.714 V.
D_P	Phase variation between analog input and output pins when the switch is ON and the dc offset of composite-video signal varies at the analog input pin. In the NTSC standard, the frequency of the video signal is 3.58 MHz, and dc offset is from 0 to 0.714 V.
I_{CC}	Static power-supply current
I_{CCD}	Variation of I_{CC} for a change in frequency in the control (\overline{EN} , IN) inputs
ΔI_{CC}	This is the increase in supply current for each control input that is at the specified voltage level, rather than V_{CC} or GND.

FUNCTIONAL DIAGRAM (POSITIVE LOGIC)

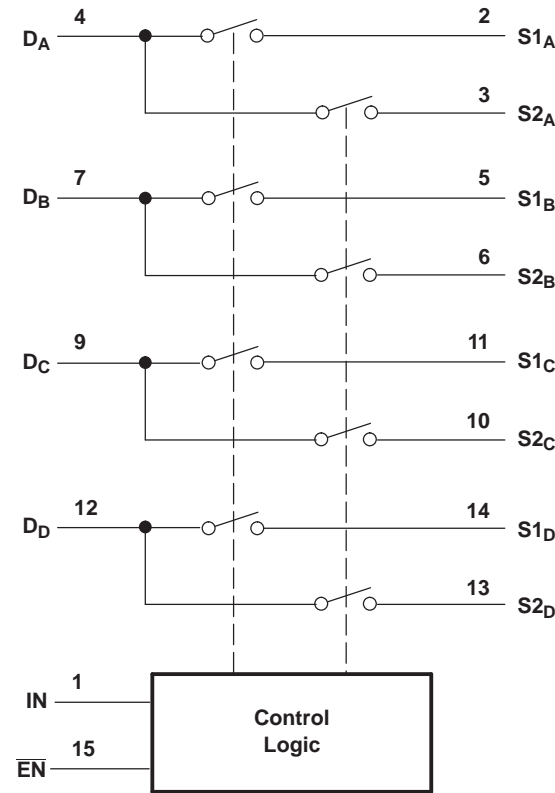

Absolute Maximum Ratings⁽¹⁾

over operating free-air temperature range (unless otherwise noted)

		MIN	MAX	UNIT
V_{CC}	Supply voltage range	-0.5	7	V
V_{IN}	Control input voltage range ⁽²⁾⁽³⁾	-0.5	7	V
$V_{I/O}$	Switch I/O voltage range ⁽²⁾⁽³⁾⁽⁴⁾	-0.5	7	V
I_{IK}	Control input clamp current		-50	mA
$I_{I/OK}$	I/O port clamp current		-50	mA
$I_{I/O}$	ON-state switch current ⁽⁵⁾		±128	mA
	Continuous current through V_{CC} or GND		±100	mA
θ_{JA}	Package thermal impedance		D package ⁽⁶⁾	73
			DBQ package ⁽⁶⁾	90
			PW package ⁽⁶⁾	108
			RGY package ⁽⁷⁾	39
T_{stg}	Storage temperature range	-65	150	°C

- (1) Stresses beyond those listed under "absolute maximum ratings" may cause permanent damage to the device. These are stress ratings only, and functional operation of the device at these or any other conditions beyond those indicated under "recommended operating conditions" is not implied. Exposure to absolute-maximum-rated conditions for extended periods may affect device reliability.
- (2) All voltages are with respect to ground, unless otherwise specified.
- (3) The input and output voltage ratings may be exceeded if the input and output clamp-current ratings are observed.
- (4) V_I and V_O are used to denote specific conditions for $V_{I/O}$.
- (5) I_I and I_O are used to denote specific conditions for $I_{I/O}$.
- (6) The package thermal impedance is calculated in accordance with JESD 51-7.
- (7) The package thermal impedance is calculated in accordance with JESD 51-5.

Recommended Operating Conditions⁽¹⁾

		MIN	MAX	UNIT
V_{CC}	Supply voltage range	4	5.5	V
V_{IH}	High-level control input voltage range (\overline{EN} , IN)	2	5.5	V
V_{IL}	Low-level control input voltage range (\overline{EN} , IN)	0	0.8	V
V_{ANALOG}	Analog I/O voltage range	0	V_{CC}	V
T_A	Operating free-air temperature range	–40	85	°C

(1) All unused control inputs of the device must be held at V_{CC} or GND to ensure proper device operation. Refer to the TI application report, *Implications of Slow or Floating CMOS Inputs*, literature number SCBA004.

Electrical Characteristics

over recommended operating free-air temperature range, $V_{CC} = 5\text{ V} \pm 10\%$ (unless otherwise noted)

PARAMETER		TEST CONDITIONS ⁽¹⁾			MIN	TYP ⁽²⁾	MAX	UNIT
V_{IK}	\overline{EN} , IN	$V_{CC} = 4.5\text{ V}$, $I_{IN} = -18\text{ mA}$					–1.8	V
V_{hys}	\overline{EN} , IN					150		mV
I_{IH}	\overline{EN} , IN	$V_{CC} = 5.5\text{ V}$, V_{IN} and $V_{EN} = V_{CC}$					± 1	μA
I_{IL}	\overline{EN} , IN	$V_{CC} = 5.5\text{ V}$, V_{IN} and $V_{EN} = \text{GND}$					± 1	μA
I_{OZ} ⁽³⁾		$V_{CC} = 5.5\text{ V}$, $V_O = 0$ to 5.5 V , $V_I = 0$, Switch OFF					± 1	μA
I_{OS} ⁽⁴⁾		$V_{CC} = 5.5\text{ V}$, $V_O = 0.5 V_{CC}$, $V_I = 0$, Switch ON			50			mA
I_{off}		$V_{CC} = 0\text{ V}$, $V_O = 0$ to 5.5 V , $V_I = 0$					1	μA
I_{CC}		$V_{CC} = 5.5\text{ V}$, $I_{I/O} = 0$, Switch ON or OFF					3	μA
ΔI_{CC}	\overline{EN} , IN	$V_{CC} = 5.5\text{ V}$, One input at 3.4 V , Other inputs at V_{CC} or GND					2.5	mA
I_{CCD}		$V_{EN} = \text{GND}$, $V_{CC} = 5.5\text{ V}$, D and S ports open, V_{IN} input switching 50% duty cycle					0.25	mA/MHz
C_{IN}	\overline{EN} , IN	V_{IN} or $V_{EN} = 0$, $f = 1\text{ MHz}$				3.5		pF
C_{OFF}	D port	$V_I = 0$, $f = 1\text{ MHz}$, Outputs open, Switch OFF				6		pF
	S port					4		
C_{ON}		$V_I = 0$, $f = 1\text{ MHz}$, Outputs open, Switch ON				14		pF
r_{on} ⁽⁵⁾		$V_{CC} = 4.5\text{ V}$	$V_I = 1\text{ V}$,	$I_O = 13\text{ mA}$,	$R_L = 75\ \Omega$	3	7	Ω
			$V_I = 2\text{ V}$,	$I_O = 26\text{ mA}$,	$R_L = 75\ \Omega$	7	10	

(1) V_I , V_O , I_I , and I_O refer to I/O pins.

(2) All typical values are at $V_{CC} = 5\text{ V}$ (unless otherwise noted), $T_A = 25^\circ\text{C}$.

(3) For I/O ports, I_{OZ} includes the input leakage current.

(4) The I_{OS} test is applicable to only one ON channel at a time. The duration of this test is less than 1 s.

(5) Measured by the voltage drop between the D and S terminals at the indicated current through the switch. ON-state resistance is determined by the lower of the voltages of the two (D or S) terminals.

Switching Characteristics

over recommended operating free-air temperature range, $V_{CC} = 5\text{ V} \pm 10\%$, $R_L = 75\ \Omega$, $C_L = 20\text{ pF}$
(unless otherwise noted) (see [Figure 5](#))

PARAMETER	FROM (INPUT)	TO (OUTPUT)	MIN	TYP	MAX	UNIT
t_{ON}	S	D		2.5	6	ns
t_{OFF}	S	D		1.1	6	ns

Dynamic Characteristics

over recommended operating free-air temperature range, $V_{CC} = 5\text{ V} \pm 10\%$ (unless otherwise noted)

PARAMETER	TEST CONDITIONS			MIN	TYP ⁽¹⁾	MAX	UNIT
$D_G^{(2)}$	$R_L = 150\ \Omega$,	$f = 3.58\text{ MHz}$,	See Figure 6		0.64		%
$D_P^{(2)}$	$R_L = 150\ \Omega$,	$f = 3.58\text{ MHz}$,	See Figure 6		0.1		Deg
BW	$R_L = 150\ \Omega$,	See Figure 7		300			MHz
X_{TALK}	$R_L = 150\ \Omega$,	$f = 10\text{ MHz}$,	$R_{IN} = 10\ \Omega$,	See Figure 8			dB
O_{IRR}	$R_L = 150\ \Omega$,	$f = 10\text{ MHz}$,	See Figure 9				dB

(1) All typical values are at $V_{CC} = 5\text{ V}$ (unless otherwise noted), $T_A = 25^\circ\text{C}$.

(2) D_G and D_P are expressed in absolute magnitude.

OPERATING CHARACTERISTICS

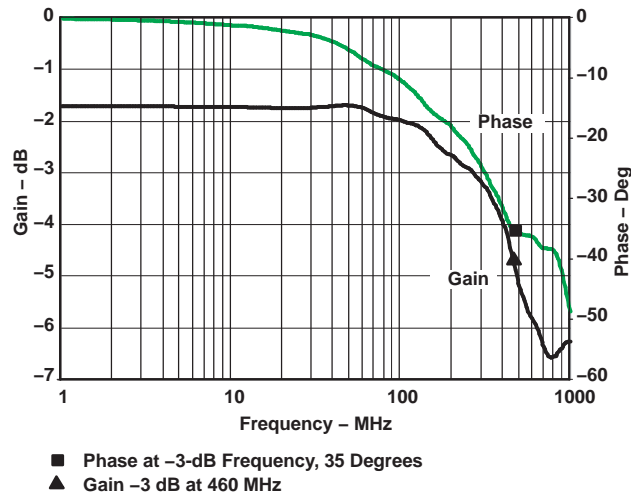

Figure 1. Gain/Phase vs Frequency

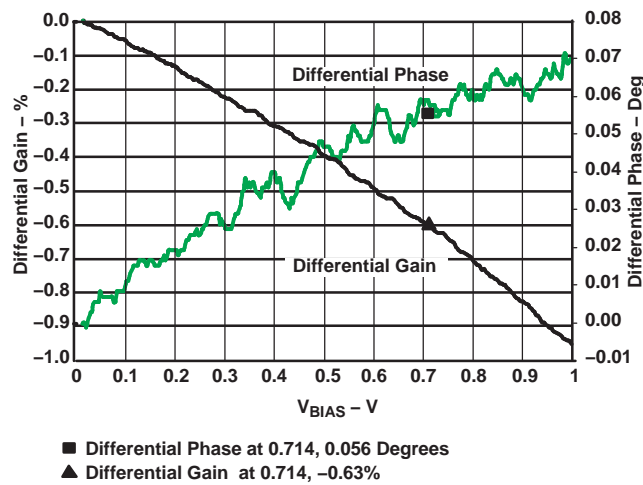

Figure 2. Differential Gain/Phase vs V_{BIAS}

OPERATING CHARACTERISTICS

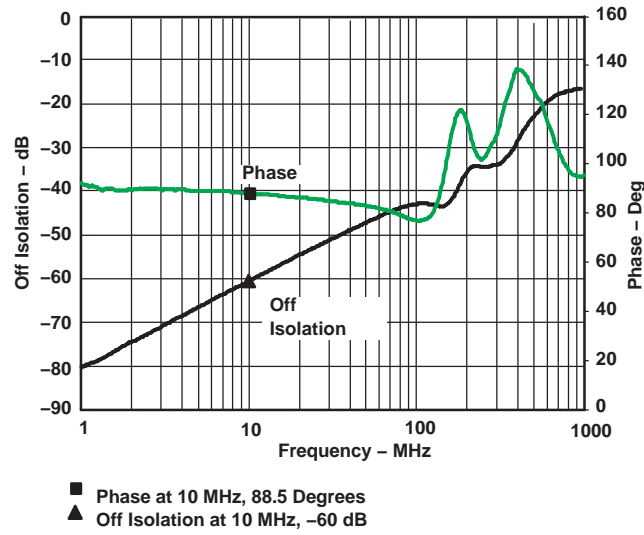

Figure 3. Off Isolation vs Frequency

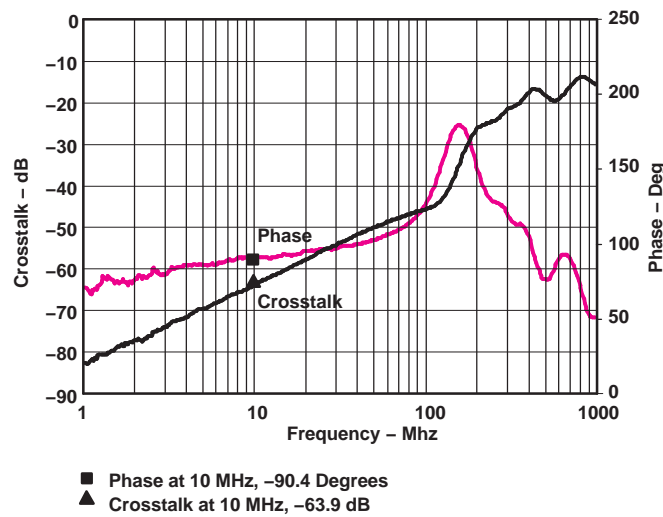
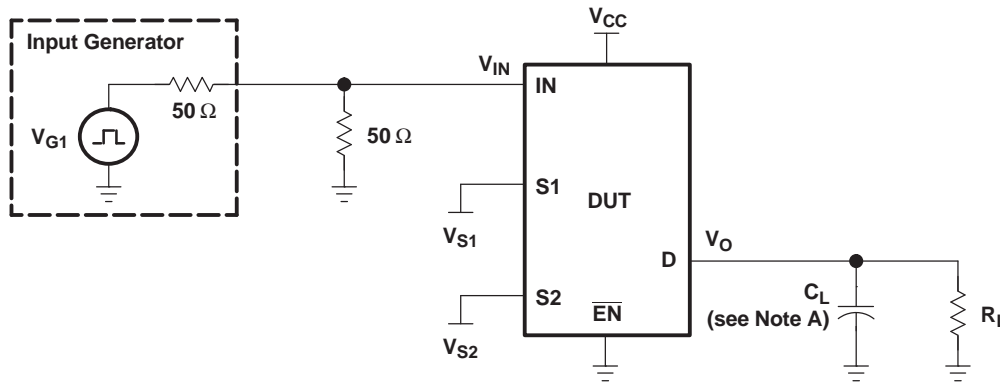
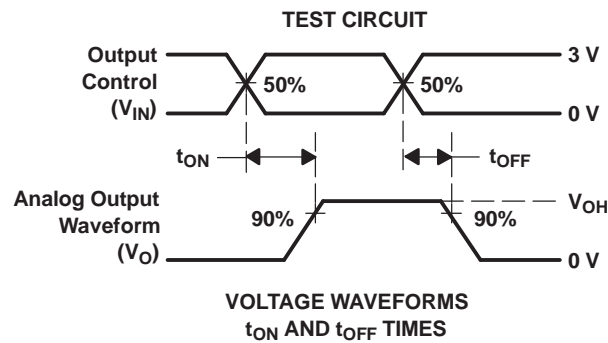

Figure 4. Crosstalk vs Frequency

PARAMETER MEASUREMENT INFORMATION



TEST	V _{CC}	R _L	C _L	V _{S1}	V _{S2}
t _{ON}	5 V ± 0.5 V	75	20	GND	3 V
	5 V ± 0.5 V	75	20	3 V	GND
t _{OFF}	5 V ± 0.5 V	75	20	GND	3 V
	5 V ± 0.5 V	75	20	3 V	GND



- NOTES: A. C_L includes probe and jig capacitance.
 B. All input pulses are supplied by generators having the following characteristics: PRR ≤ 10 MHz, Z_O = 50 Ω, t_r ≤ 2.5 ns, t_f ≤ 2.5 ns.
 C. The outputs are measured one at a time, with one transition per measurement.

Figure 5. Test Circuit and Voltage Waveforms

PARAMETER MEASUREMENT INFORMATION

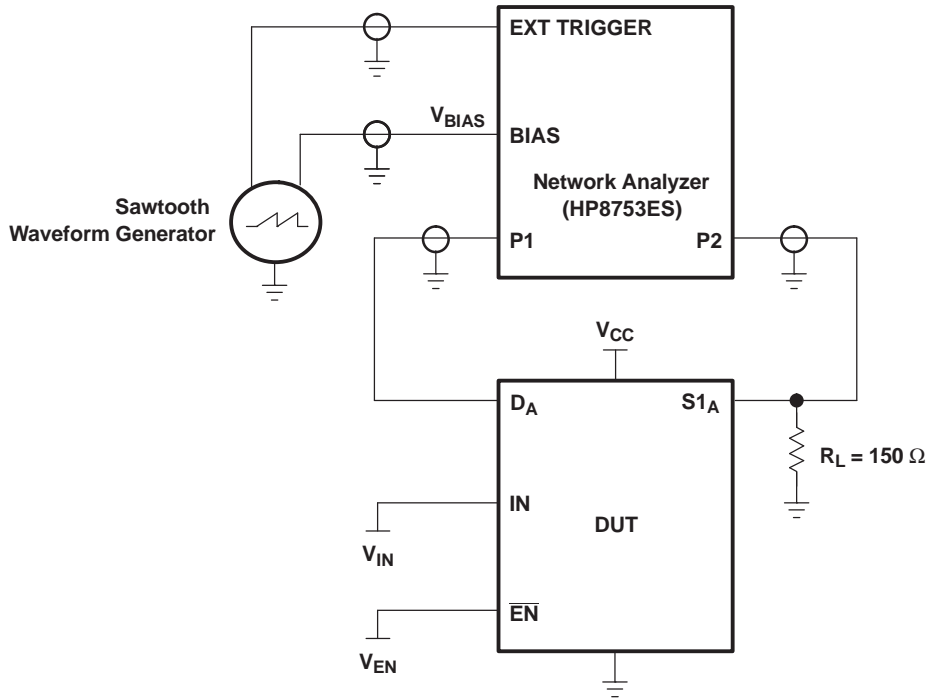

NOTE A: For additional information on measurement method, refer to the TI application report, *Measuring Differential Gain and Phase*, literature number SLOA040.

Figure 6. Test Circuit for Differential Gain/Phase Measurement

Differential gain and phase are measured at the output of the ON channel. For example, when $V_{IN} = 0$, $V_{EN} = 0$, and DA is the input, the output is measured at S1_A.

HP8753ES Setup

Average = 20 RBW = 300 Hz ST = 1.381 s P1 = -7 dBm CW frequency = 3.58 MHz		
--	--	--

Sawtooth Waveform Generator Setup

$V_{BIAS} = 0$ to 1 V Frequency = 0.905 Hz

PARAMETER MEASUREMENT INFORMATION

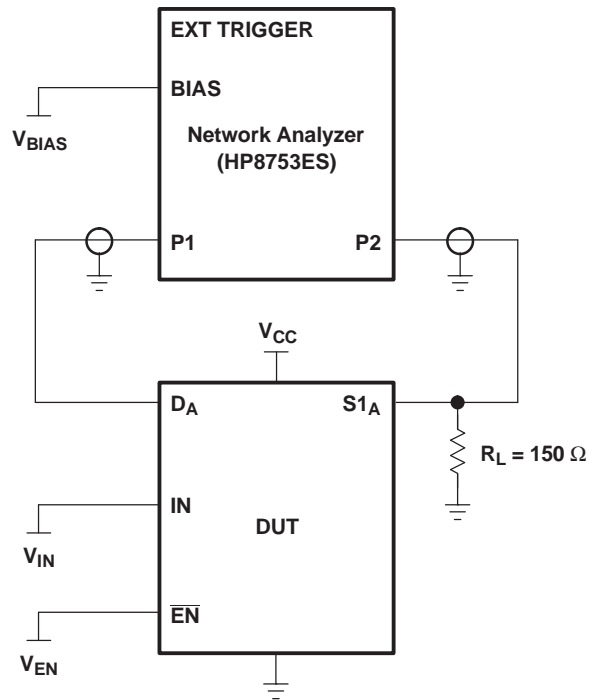

Figure 7. Test Circuit for Frequency Response (BW)

Frequency response is measured at the output of the ON channel. For example, when $V_{IN} = 0$, $V_{EN} = 0$, and D_A is the input, the output is measured at $S1_A$. All unused analog I/O ports are left open.

HP8753ES Setup

Average = 4
 RBW = 3 Hz
 $V_{BIAS} = 0.35\text{ V}$
 ST = 2 s
 P1 = 0 dBm

PARAMETER MEASUREMENT INFORMATION

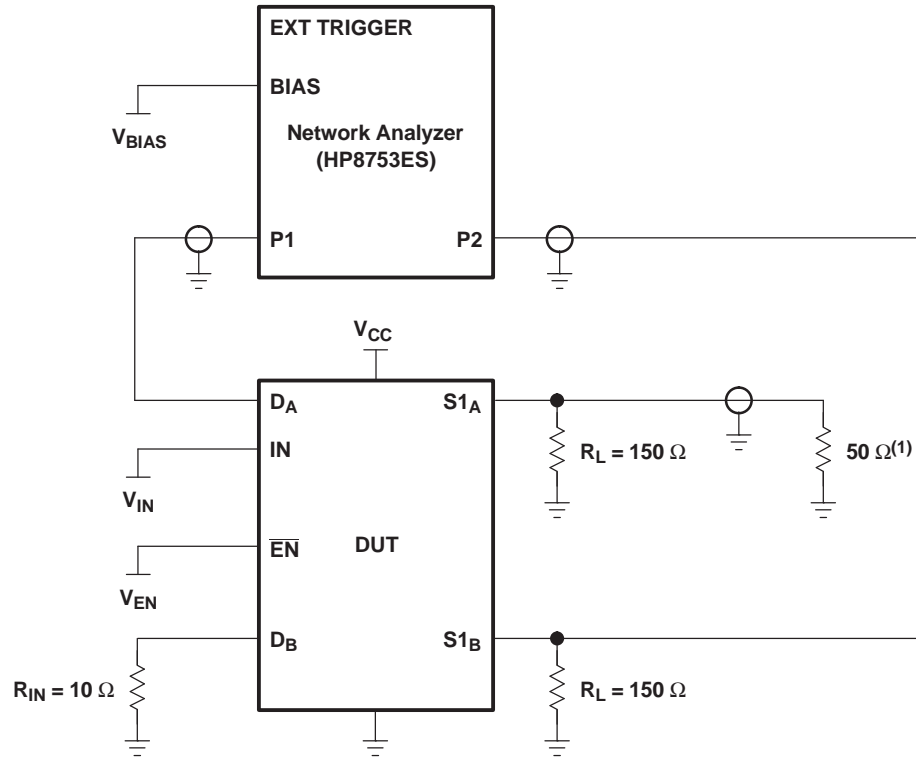

(1) A 50-Ω termination resistor is needed for the network analyzer.

Figure 8. Test Circuit for Crosstalk (X_{TALK})

Crosstalk is measured at the output of the nonadjacent ON channel. For example, when $V_{IN} = 0$, $V_{EN} = 0$, and D_A is the input, the output is measured at $S1_B$. All unused analog input (D) ports and output (S) ports are connected to GND through 10-Ω and 50-Ω pulldown resistors, respectively.

HP8753ES Setup

Average = 4
 RBW = 3 kHz
 $V_{BIAS} = 0.35$ V
 ST = 2 s
 P1 = 0 dBm

PARAMETER MEASUREMENT INFORMATION

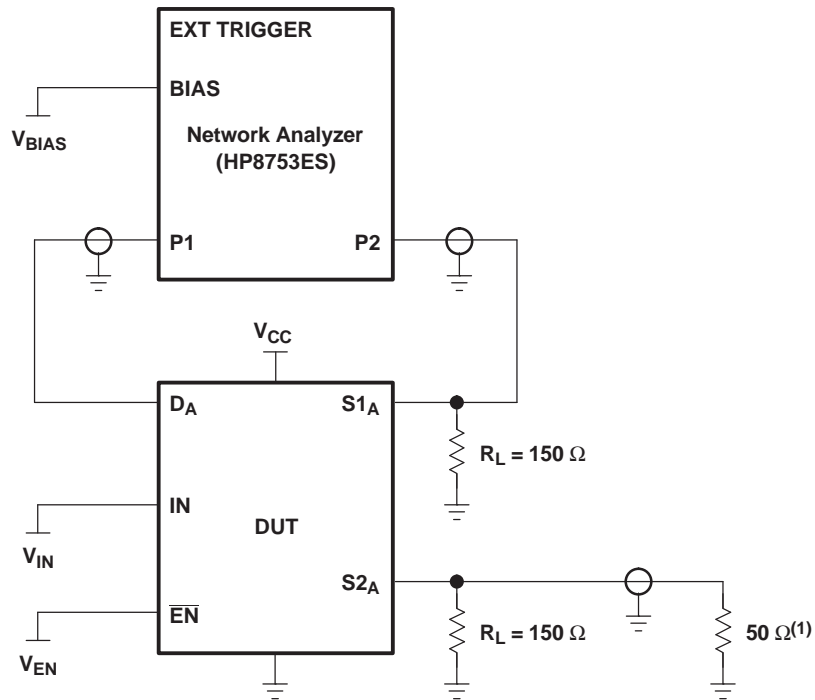

(1) A 50-Ω termination resistor is needed for the network analyzer.

Figure 9. Test Circuit for Off Isolation (O_{IRR})

Off isolation is measured at the output of the OFF channel. For example, when $V_{IN} = V_{CC}$, $V_{EN} = 0$, and D_A is the input, the output is measured at $S1_A$. All unused analog input (D) ports are left open, and output (S) ports are connected to GND through 50-Ω pulldown resistors.

HP8753ES Setup

Average = 4
 RBW = 3 kHz
 $V_{BIAS} = 0.35\text{ V}$
 ST = 2 s
 P1 = 0 dBM

PACKAGING INFORMATION

Orderable Device	Status ⁽¹⁾	Package Type	Package Drawing	Pins	Package Qty	Eco Plan ⁽²⁾	Lead/Ball Finish	MSL Peak Temp ⁽³⁾
TS5V330D	ACTIVE	SOIC	D	16	40	Green (RoHS & no Sb/Br)	CU NIPDAU	Level-1-260C-UNLIM
TS5V330DBQR	ACTIVE	SSOP/ QSOP	DBQ	16	2500	Green (RoHS & no Sb/Br)	CU NIPDAU	Level-2-260C-1 YEAR
TS5V330DBQRE4	ACTIVE	SSOP/ QSOP	DBQ	16	2500	Green (RoHS & no Sb/Br)	CU NIPDAU	Level-2-260C-1 YEAR
TS5V330DBQRG4	ACTIVE	SSOP/ QSOP	DBQ	16	2500	Green (RoHS & no Sb/Br)	CU NIPDAU	Level-2-260C-1 YEAR
TS5V330DE4	ACTIVE	SOIC	D	16	40	Green (RoHS & no Sb/Br)	CU NIPDAU	Level-1-260C-UNLIM
TS5V330DG4	ACTIVE	SOIC	D	16	40	Green (RoHS & no Sb/Br)	CU NIPDAU	Level-1-260C-UNLIM
TS5V330DR	ACTIVE	SOIC	D	16	2500	Green (RoHS & no Sb/Br)	CU NIPDAU	Level-1-260C-UNLIM
TS5V330DRE4	ACTIVE	SOIC	D	16	2500	Green (RoHS & no Sb/Br)	CU NIPDAU	Level-1-260C-UNLIM
TS5V330DRG4	ACTIVE	SOIC	D	16	2500	Green (RoHS & no Sb/Br)	CU NIPDAU	Level-1-260C-UNLIM
TS5V330PW	ACTIVE	TSSOP	PW	16	90	Green (RoHS & no Sb/Br)	CU NIPDAU	Level-1-260C-UNLIM
TS5V330PWE4	ACTIVE	TSSOP	PW	16	90	Green (RoHS & no Sb/Br)	CU NIPDAU	Level-1-260C-UNLIM
TS5V330PWG4	ACTIVE	TSSOP	PW	16	90	Green (RoHS & no Sb/Br)	CU NIPDAU	Level-1-260C-UNLIM
TS5V330PWR	ACTIVE	TSSOP	PW	16	2000	Green (RoHS & no Sb/Br)	CU NIPDAU	Level-1-260C-UNLIM
TS5V330PWRE4	ACTIVE	TSSOP	PW	16	2000	Green (RoHS & no Sb/Br)	CU NIPDAU	Level-1-260C-UNLIM
TS5V330PWRG4	ACTIVE	TSSOP	PW	16	2000	Green (RoHS & no Sb/Br)	CU NIPDAU	Level-1-260C-UNLIM
TS5V330RGYR	ACTIVE	VQFN	RGY	16	3000	Green (RoHS & no Sb/Br)	CU NIPDAU	Level-2-260C-1 YEAR
TS5V330RGYRG4	ACTIVE	VQFN	RGY	16	3000	Green (RoHS & no Sb/Br)	CU NIPDAU	Level-2-260C-1 YEAR

⁽¹⁾ The marketing status values are defined as follows:

ACTIVE: Product device recommended for new designs.

LIFEBUY: TI has announced that the device will be discontinued, and a lifetime-buy period is in effect.

NRND: Not recommended for new designs. Device is in production to support existing customers, but TI does not recommend using this part in a new design.

PREVIEW: Device has been announced but is not in production. Samples may or may not be available.

OBsolete: TI has discontinued the production of the device.

⁽²⁾ Eco Plan - The planned eco-friendly classification: Pb-Free (RoHS), Pb-Free (RoHS Exempt), or Green (RoHS & no Sb/Br) - please check <http://www.ti.com/productcontent> for the latest availability information and additional product content details.

TBD: The Pb-Free/Green conversion plan has not been defined.

Pb-Free (RoHS): TI's terms "Lead-Free" or "Pb-Free" mean semiconductor products that are compatible with the current RoHS requirements for all 6 substances, including the requirement that lead not exceed 0.1% by weight in homogeneous materials. Where designed to be soldered at high temperatures, TI Pb-Free products are suitable for use in specified lead-free processes.

Pb-Free (RoHS Exempt): This component has a RoHS exemption for either 1) lead-based flip-chip solder bumps used between the die and package, or 2) lead-based die adhesive used between the die and leadframe. The component is otherwise considered Pb-Free (RoHS compatible) as defined above.

Green (RoHS & no Sb/Br): TI defines "Green" to mean Pb-Free (RoHS compatible), and free of Bromine (Br) and Antimony (Sb) based flame

retardants (Br or Sb do not exceed 0.1% by weight in homogeneous material)

(3) MSL, Peak Temp. -- The Moisture Sensitivity Level rating according to the JEDEC industry standard classifications, and peak solder temperature.

Important Information and Disclaimer:The information provided on this page represents TI's knowledge and belief as of the date that it is provided. TI bases its knowledge and belief on information provided by third parties, and makes no representation or warranty as to the accuracy of such information. Efforts are underway to better integrate information from third parties. TI has taken and continues to take reasonable steps to provide representative and accurate information but may not have conducted destructive testing or chemical analysis on incoming materials and chemicals. TI and TI suppliers consider certain information to be proprietary, and thus CAS numbers and other limited information may not be available for release.

In no event shall TI's liability arising out of such information exceed the total purchase price of the TI part(s) at issue in this document sold by TI to Customer on an annual basis.

TAPE AND REEL INFORMATION

QUADRANT ASSIGNMENTS FOR PIN 1 ORIENTATION IN TAPE

*All dimensions are nominal

Device	Package Type	Package Drawing	Pins	SPQ	Reel Diameter (mm)	Reel Width W1 (mm)	A0 (mm)	B0 (mm)	K0 (mm)	P1 (mm)	W (mm)	Pin1 Quadrant
TS5V330DR	SOIC	D	16	2500	330.0	16.4	6.5	10.3	2.1	8.0	16.0	Q1
TS5V330PWR	TSSOP	PW	16	2000	330.0	12.4	6.9	5.6	1.6	8.0	12.0	Q1
TS5V330RGYR	VQFN	RGY	16	3000	330.0	12.4	3.8	4.3	1.5	8.0	12.0	Q1

TAPE AND REEL BOX DIMENSIONS

*All dimensions are nominal

Device	Package Type	Package Drawing	Pins	SPQ	Length (mm)	Width (mm)	Height (mm)
TS5V330DR	SOIC	D	16	2500	333.2	345.9	28.6
TS5V330PWR	TSSOP	PW	16	2000	346.0	346.0	29.0
TS5V330RGYR	VQFN	RGY	16	3000	346.0	346.0	29.0

D(R-PDSO-G16)

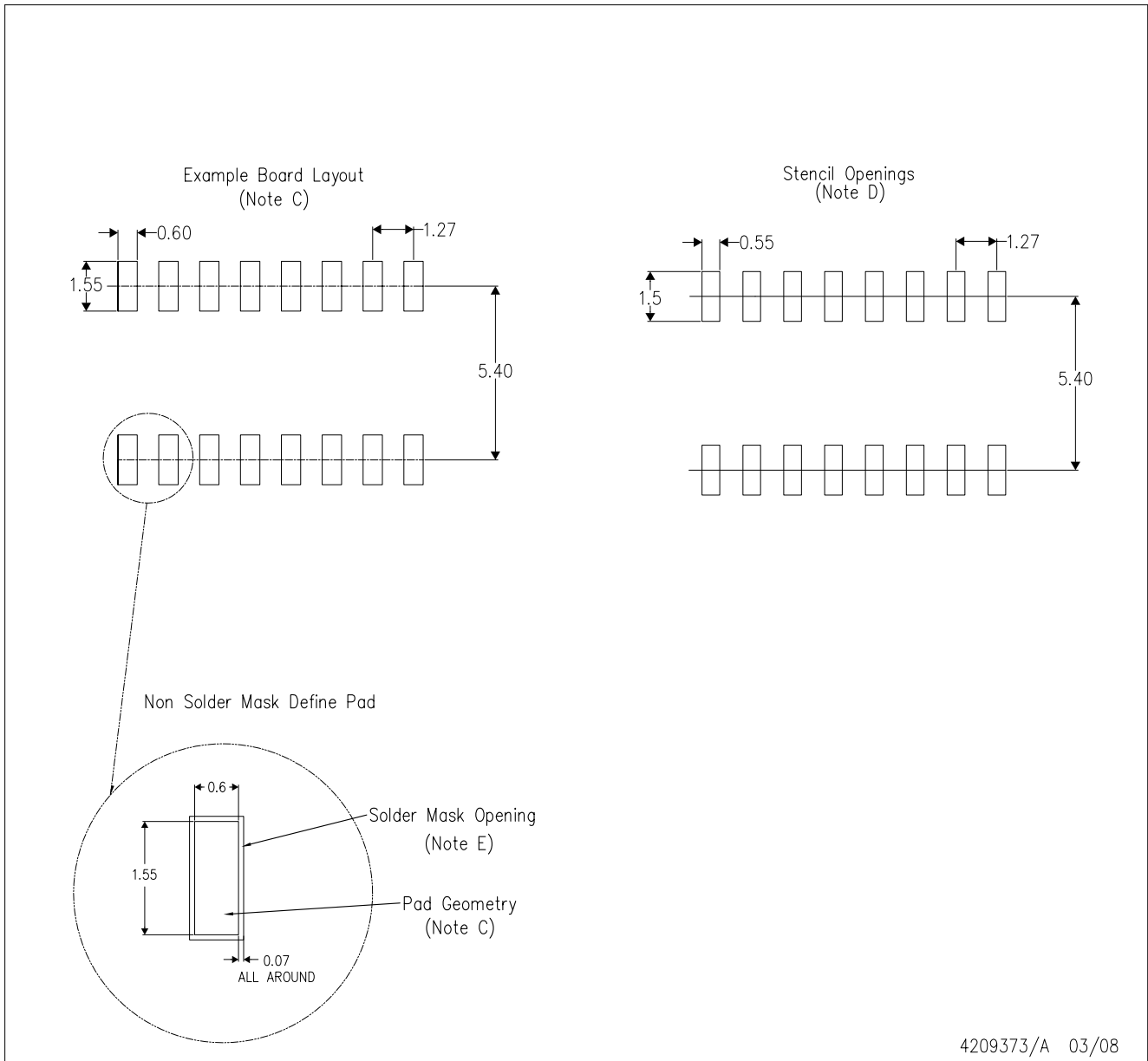



4209373/A 03/08

- NOTES:
- A. All linear dimensions are in millimeters.
 - B. This drawing is subject to change without notice.
 - C. Refer to IPC7351 for alternate board design.
 - D. Laser cutting apertures with trapezoidal walls and also rounding corners will offer better paste release. Customers should contact their board assembly site for stencil design recommendations. Refer to IPC-7525
 - E. Customers should contact their board fabrication site for solder mask tolerances between and around signal pads.

RGY (R-PVQFN-N16)

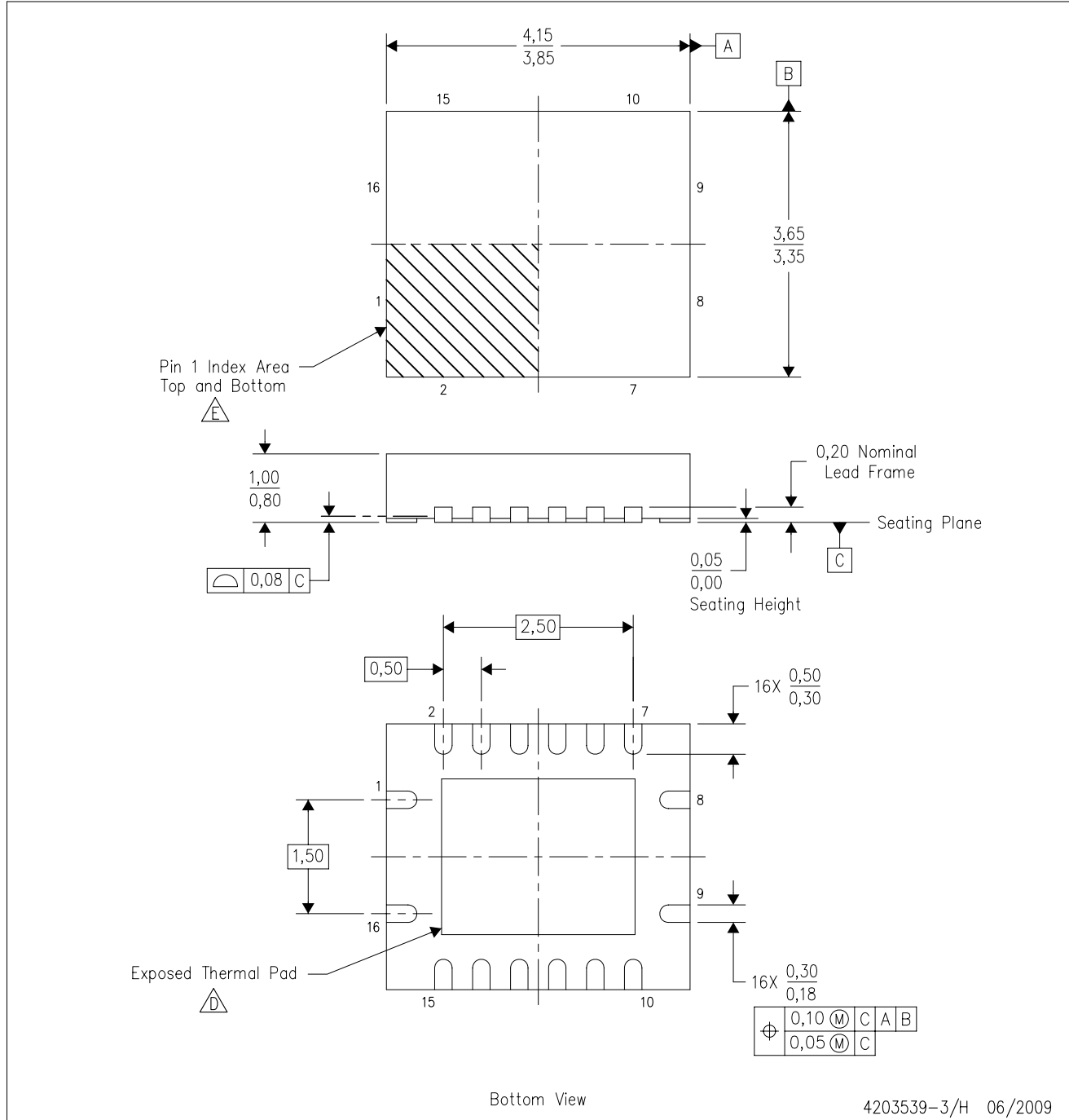
PLASTIC QUAD FLATPACK NO-LEAD



- NOTES:
- A. All linear dimensions are in millimeters. Dimensioning and tolerancing per ASME Y14.5M-1994.
 - B. This drawing is subject to change without notice.
 - C. QFN (Quad Flatpack No-Lead) package configuration.
 -  The package thermal pad must be soldered to the board for thermal and mechanical performance. See the Product Data Sheet for details regarding the exposed thermal pad dimensions.
 -  Pin 1 identifiers are located on both top and bottom of the package and within the zone indicated. The Pin 1 identifiers are either a molded, marked, or metal feature.
 - F. Package complies to JEDEC MO-241 variation BB.

DBQ (R-PDSO-G16)

PLASTIC SMALL-OUTLINE PACKAGE

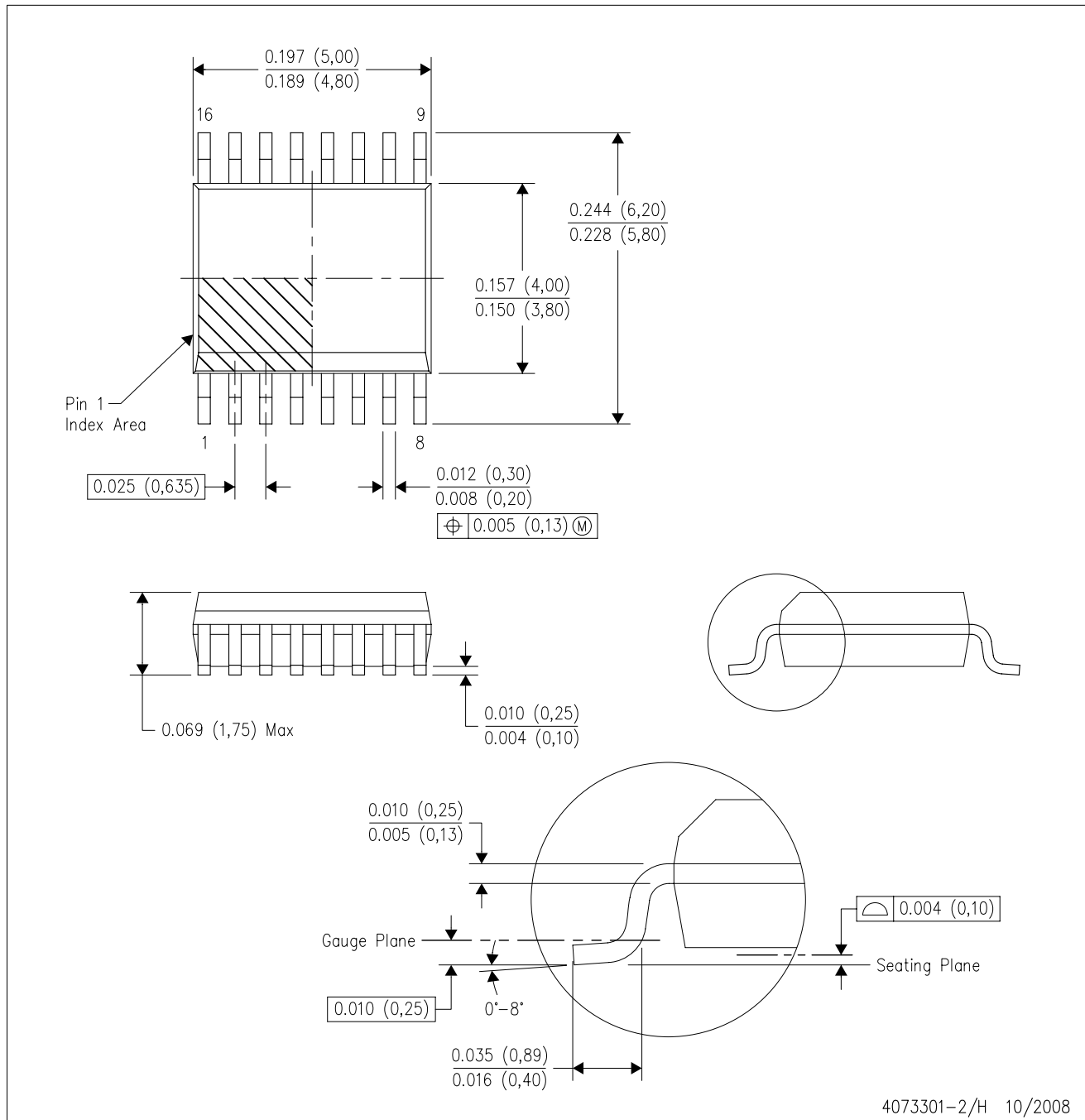

- NOTES:
- A. All linear dimensions are in inches (millimeters).
 - B. This drawing is subject to change without notice.
 - C. Body dimensions do not include mold flash or protrusion not to exceed 0.006 (0,15) per side.
 - D. Falls within JEDEC MO-137 variation AB.

DBQ (R-PDSO-G16)

PLASTIC SMALL OUTLINE PACKAGE

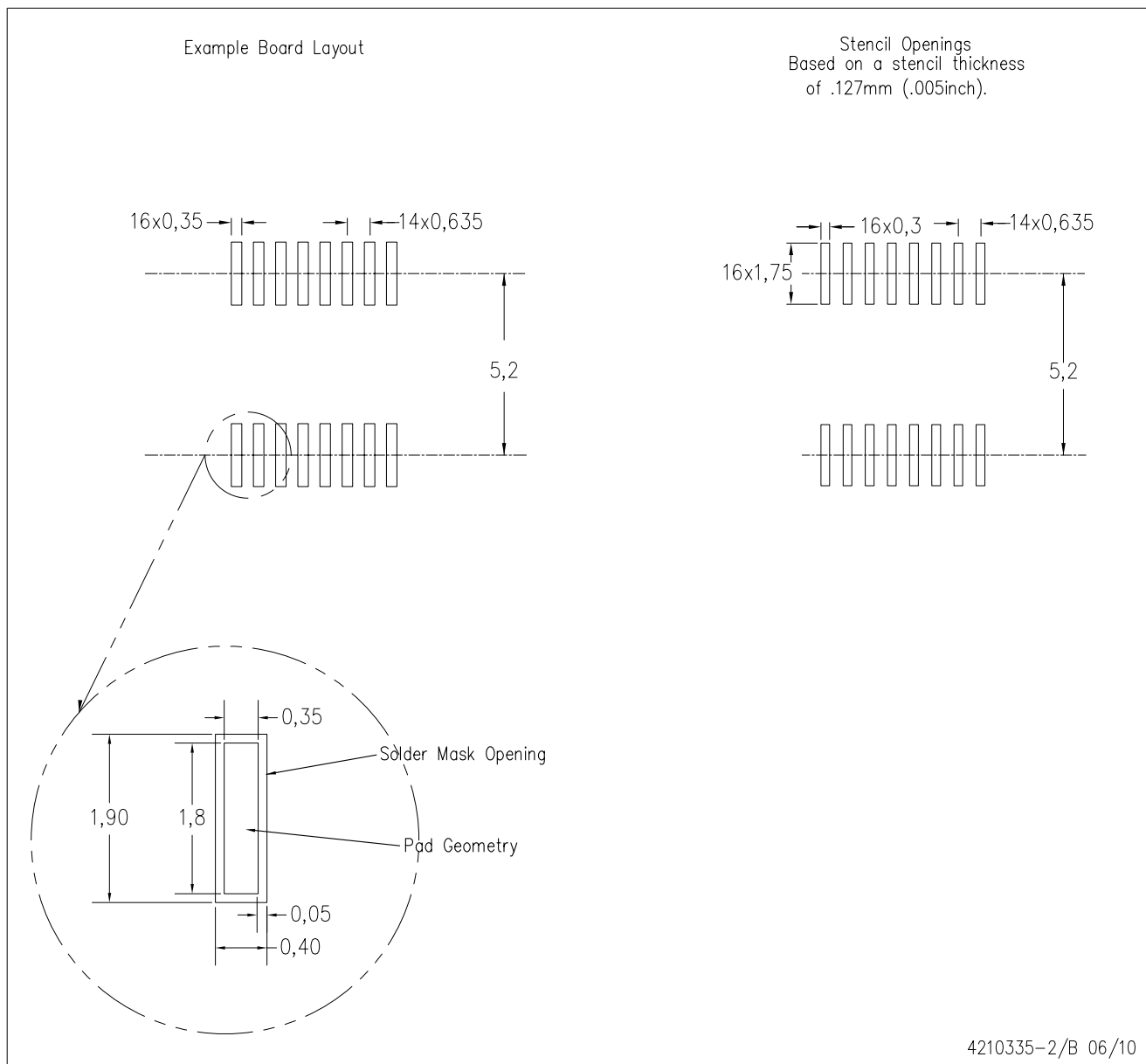

4210335-2/B 06/10

- NOTES:
- A. All linear dimensions are in millimeters.
 - B. This drawing is subject to change without notice.
 - C. Customers should place a note on the circuit board fabrication drawing not to alter the center solder mask defined pad.
 - D. Publication IPC-7351 is recommended for alternate designs.
 - E. Laser cutting apertures with trapezoidal walls and also rounding corners will offer better paste release. Customers should contact their board assembly site for stencil design recommendations. Example stencil design based on a 50% volumetric metal load solder paste. Refer to IPC-7525 for other stencil recommendations.

PW (R-PDSO-G**)

PLASTIC SMALL-OUTLINE PACKAGE

14 PINS SHOWN



4040064/F 01/97

- NOTES: A. All linear dimensions are in millimeters.
 B. This drawing is subject to change without notice.
 C. Body dimensions do not include mold flash or protrusion not to exceed 0,15.
 D. Falls within JEDEC MO-153

IMPORTANT NOTICE

Texas Instruments Incorporated and its subsidiaries (TI) reserve the right to make corrections, modifications, enhancements, improvements, and other changes to its products and services at any time and to discontinue any product or service without notice. Customers should obtain the latest relevant information before placing orders and should verify that such information is current and complete. All products are sold subject to TI's terms and conditions of sale supplied at the time of order acknowledgment.

TI warrants performance of its hardware products to the specifications applicable at the time of sale in accordance with TI's standard warranty. Testing and other quality control techniques are used to the extent TI deems necessary to support this warranty. Except where mandated by government requirements, testing of all parameters of each product is not necessarily performed.

TI assumes no liability for applications assistance or customer product design. Customers are responsible for their products and applications using TI components. To minimize the risks associated with customer products and applications, customers should provide adequate design and operating safeguards.

TI does not warrant or represent that any license, either express or implied, is granted under any TI patent right, copyright, mask work right, or other TI intellectual property right relating to any combination, machine, or process in which TI products or services are used. Information published by TI regarding third-party products or services does not constitute a license from TI to use such products or services or a warranty or endorsement thereof. Use of such information may require a license from a third party under the patents or other intellectual property of the third party, or a license from TI under the patents or other intellectual property of TI.

Reproduction of TI information in TI data books or data sheets is permissible only if reproduction is without alteration and is accompanied by all associated warranties, conditions, limitations, and notices. Reproduction of this information with alteration is an unfair and deceptive business practice. TI is not responsible or liable for such altered documentation. Information of third parties may be subject to additional restrictions.

Resale of TI products or services with statements different from or beyond the parameters stated by TI for that product or service voids all express and any implied warranties for the associated TI product or service and is an unfair and deceptive business practice. TI is not responsible or liable for any such statements.

TI products are not authorized for use in safety-critical applications (such as life support) where a failure of the TI product would reasonably be expected to cause severe personal injury or death, unless officers of the parties have executed an agreement specifically governing such use. Buyers represent that they have all necessary expertise in the safety and regulatory ramifications of their applications, and acknowledge and agree that they are solely responsible for all legal, regulatory and safety-related requirements concerning their products and any use of TI products in such safety-critical applications, notwithstanding any applications-related information or support that may be provided by TI. Further, Buyers must fully indemnify TI and its representatives against any damages arising out of the use of TI products in such safety-critical applications.

TI products are neither designed nor intended for use in military/aerospace applications or environments unless the TI products are specifically designated by TI as military-grade or "enhanced plastic." Only products designated by TI as military-grade meet military specifications. Buyers acknowledge and agree that any such use of TI products which TI has not designated as military-grade is solely at the Buyer's risk, and that they are solely responsible for compliance with all legal and regulatory requirements in connection with such use.

TI products are neither designed nor intended for use in automotive applications or environments unless the specific TI products are designated by TI as compliant with ISO/TS 16949 requirements. Buyers acknowledge and agree that, if they use any non-designated products in automotive applications, TI will not be responsible for any failure to meet such requirements.

Following are URLs where you can obtain information on other Texas Instruments products and application solutions:

Products		Applications	
Amplifiers	amplifier.ti.com	Audio	www.ti.com/audio
Data Converters	dataconverter.ti.com	Automotive	www.ti.com/automotive
DLP® Products	www.dlp.com	Communications and Telecom	www.ti.com/communications
DSP	dsp.ti.com	Computers and Peripherals	www.ti.com/computers
Clocks and Timers	www.ti.com/clocks	Consumer Electronics	www.ti.com/consumer-apps
Interface	interface.ti.com	Energy	www.ti.com/energy
Logic	logic.ti.com	Industrial	www.ti.com/industrial
Power Mgmt	power.ti.com	Medical	www.ti.com/medical
Microcontrollers	microcontroller.ti.com	Security	www.ti.com/security
RFID	www.ti-rfid.com	Space, Avionics & Defense	www.ti.com/space-avionics-defense
RF/IF and ZigBee® Solutions	www.ti.com/lprf	Video and Imaging	www.ti.com/video
		Wireless	www.ti.com/wireless-apps