

Description

The TS5A4594 is a single-pole single-throw (SPST) analog switch that is designed to operate from 2 V to 5.5 V. This device can handle both digital and analog signals, and signals up to V_+ can be transmitted in either direction.

Applications

- Sample-and-Hold Circuits
- Battery-Powered Equipment (Cellular Phones, PDAs)
- Audio and Video Signal Routing
- Communication Circuits
- PCMCIA Cards

Features

- Low ON-State Resistance (8 Ω)
- ON-State Resistance Flatness (1.5 Ω)
- Control Inputs Are 5.5-V Tolerant
- Low Charge Injection (5 pC Max)
- 450-MHz –3-dB Bandwidth at 25°C
- Low Total Harmonic Distortion (THD) (0.04%)
- 2-V to 5.5-V Single-Supply Operation
- Specified at 5-V and 3.3-V Nodes
- –82-dB OFF-Isolation at 1 MHz
- Latch-Up Performance Exceeds 100 mA Per JESD 78, Class II
- 0.5-nA Max OFF Leakage
- ESD Performance Tested Per JESD 22
 - 2000-V Human-Body Model (A114-B, Class II)
 - 1000-V Charged-Device Model (C101)
- TTL/CMOS-Logic Compatible

Summary of Characteristics

$V_+ = 5\text{ V}$, $T_A = 25^\circ\text{C}$

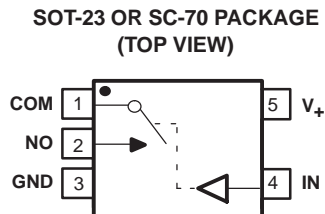

FUNCTION TABLE

IN	NO TO COM, COM TO NO
L	OFF
H	ON

Configuration	Single Pole Single Throw (SPST)
Number of channels	1
ON-state resistance (r_{ON})	8 Ω
ON-state resistance flatness ($r_{ON(FLAT)}$)	1.5 Ω
Turn-on/turn-off time (t_{ON}/t_{OFF})	17 ns/14 ns
Charge injection (Q_C)	5 pC
Bandwidth (BW)	450 MHz
OFF isolation (O_{ISO})	–82 dB at 1 MHz
Total harmonic distortion (THD)	0.04%
Leakage current ($I_{COM(OFF)}/I_{NO(OFF)}$)	±0.5 nA
Power-supply current (I_+)	0.25 μA
Package option	5-pin SOT-23 or SC-70

ORDERING INFORMATION

T_A	PACKAGE ⁽¹⁾		ORDERABLE PART NUMBER	TOP-SIDE MARKING ⁽²⁾
–40°C to 85°C	SOT (SOT-23) – DBV	Tape and reel	TS5A4594DBVR	JSA_
	SOT (SC-70) – DCK	Tape and reel	TS5A4594DCKR	JS_

- (1) Package drawings, standard packing quantities, thermal data, symbolization, and PCB design guidelines are available at www.ti.com/sc/package.
 (2) DBV/DCK: The actual top-side marking has one additional character that designates the assembly/test site.



Please be aware that an important notice concerning availability, standard warranty, and use in critical applications of Texas Instruments semiconductor products and disclaimers thereto appears at the end of this data sheet.

TS5A4594 SINGLE-CHANNEL 8-Ω SPST ANALOG SWITCH

SCDS179 – FEBRUARY 2005

Pin Configurations

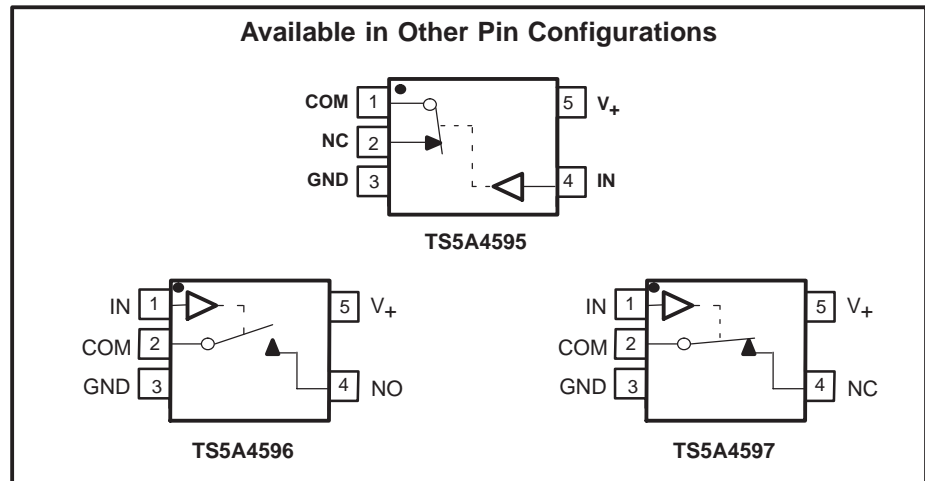
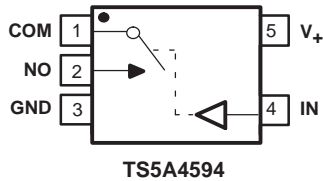

Absolute Minimum and Maximum Ratings⁽¹⁾⁽²⁾

over operating free-air temperature range (unless otherwise noted)

		MIN	MAX	UNIT
V_+	Supply voltage range ⁽³⁾	-0.3	6	V
V_{NO} V_{COM}	Analog voltage range ⁽³⁾⁽⁴⁾	-0.3	$V_+ + 0.3$	V
I_K	Analog port diode current	$V_{NO}, V_{COM} < 0$		mA
I_{NO} I_{COM}	On-state switch current	$V_{NO}, V_{COM} = 0$ to V_+		mA
I_{NO} I_{COM}	On-state switch current (pulsed at 1 ms, 10% duty cycle)	$V_{NO}, V_{COM} = 0$ to V_+		mA
V_I	Digital input voltage range ⁽³⁾⁽⁴⁾	-0.3	6	V
I_{IK}	Digital input clamp current	$V_I < 0$		mA
I_+	Continuous current through V_+		100	mA
I_{GND}	Continuous current through GND	-100		mA
θ_{JA}	Package thermal impedance ⁽⁵⁾	DBV package		206
		DCK package		252
T_{Stg}	Storage temperature range	-65	150	°C

(1) Stresses above these ratings may cause permanent damage. Exposure to absolute maximum conditions for extended periods may degrade device reliability. These are stress ratings only, and functional operation of the device at these or any other conditions beyond those specified is not implied.

(2) The algebraic convention, whereby the most negative value is a minimum and the most positive value is a maximum

(3) All voltages are with respect to ground, unless otherwise specified.

(4) The input and output voltage ratings may be exceeded if the input and output clamp-current ratings are observed.

(5) The package thermal impedance is calculated in accordance with JESD 51-7.

Electrical Characteristics for 5-V Supply⁽¹⁾

$V_+ = 4.5\text{ V to }5.5\text{ V}$, $V_{IH} = 2.4\text{ V}$, $V_{IL} = 0.8\text{ V}$, $T_A = -40^\circ\text{C to }85^\circ\text{C}$ (unless otherwise noted)

PARAMETER	SYMBOL	TEST CONDITIONS	T_A	V_+	MIN	TYP	MAX	UNIT
Analog Switch								
Analog signal range	V_{COM} , V_{NO}				0		V_+	V
ON-state resistance	r_{on}	$V_{NO} = 3.5\text{ V}$, $I_{COM} = 10\text{ mA}$,	Switch ON, See Figure 13	25°C Full	4.5 V	5	8 10	Ω
ON-state resistance flatness	$r_{on(Flat)}$	$V_{NO} = 1.5\text{ V}, 2.5\text{ V}, 3.5\text{ V}$, $I_{COM} = 10\text{ mA}$,	Switch ON, See Figure 13	25°C Full	4.5 V	0.5	1.5 2	Ω
NO OFF leakage current	$I_{NO(OFF)}$	$V_{NO} = 1\text{ V}$, $V_{COM} = 4.5\text{ V}$, or $V_{NO} = 4.5\text{ V}$, $V_{COM} = 1\text{ V}$,	Switch OFF, See Figure 14	25°C Full	5.5 V	-0.5	0.01 0.5 5	nA
COM OFF leakage current	$I_{COM(OFF)}$	$V_{COM} = 1\text{ V}$, $V_{NO} = 4.5\text{ V}$, or $V_{COM} = 4.5\text{ V}$, $V_{NO} = 1\text{ V}$,	Switch OFF, See Figure 14	25°C Full	5.5 V	-0.5	0.01 0.5 5	nA
NO ON leakage current	$I_{NO(ON)}$	$V_{NO} = 1\text{ V}$, $V_{COM} = 1\text{ V}$, or $V_{NO} = 4.5\text{ V}$, $V_{COM} = 4.5\text{ V}$, or $V_{NO} = 1\text{ V}$, 4.5 V , $V_{COM} = \text{Open}$,	Switch ON, See Figure 15	25°C Full	5.5 V	-1	0.01 1 10	nA
COM ON leakage current	$I_{COM(ON)}$	$V_{COM} = 1\text{ V}$, $V_{NO} = 1\text{ V}$, or $V_{COM} = 4.5\text{ V}$, $V_{NO} = 4.5\text{ V}$, or $V_{COM} = 1\text{ V}$, 4.5 V , $V_{NO} = \text{Open}$,	Switch ON, See Figure 15	25°C Full	5.5 V	-1	0.01 1 10	nA
Digital Control Input (IN)								
Input logic high	V_{IH}			Full		2.4	5.5	V
Input logic low	V_{IL}			Full		0	0.8	V
Input leakage current	I_{IH} , I_{IL}	$V_I = V_+$ or 0		25°C Full	5 V	-0.5	0.01 0.5 5	μA

(1) The algebraic convention, whereby the most negative value is a minimum and the most positive value is a maximum

TS5A4594 SINGLE-CHANNEL 8-Ω SPST ANALOG SWITCH

SCDS179 – FEBRUARY 2005

Electrical Characteristics for 5-V Supply⁽¹⁾ (continued)

V_+ = 4.5 V to 5.5 V, T_A = -40°C to 85°C (unless otherwise noted)

PARAMETER	SYMBOL	TEST CONDITIONS	T_A	V_+	MIN	TYP	MAX	UNIT
Dynamic								
Turn-on time	t_{ON}	$V_{NO} = 3\text{ V}$, $R_L = 300\ \Omega$, $C_L = 35\text{ pF}$, See Figure 17	25°C	5 V	12	17	ns	
			Full	4.5 V to 5.5 V	19			
Turn-off time	t_{OFF}	$V_{COM} = 3\text{ V}$, $R_L = 300\ \Omega$, $C_L = 35\text{ pF}$, See Figure 17	25°C	5 V	9	14	ns	
			Full	4.5 V to 5.5 V	17			
Charge injection	Q_C	$V_{GEN} = 0$, $R_{GEN} = 0$ $C_L = 1\text{ nF}$, See Figure 20	25°C	5 V	2	5	pC	
NO OFF capacitance	$C_{NO(OFF)}$	$V_{NO} = 0\text{ V}$, $f = 1\text{ MHz}$ Switch OFF, See Figure 16	25°C	5 V	6.5		pF	
COM OFF capacitance	$C_{COM(OFF)}$	$V_{COM} = 0\text{ V}$, $f = 1\text{ MHz}$, Switch OFF, See Figure 16	25°C	5 V	6.5		pF	
NO ON capacitance	$C_{NO(ON)}$	$V_{NO} = 0\text{ V}$, $f = 1\text{ MHz}$, Switch ON, See Figure 16	25°C	5 V	13		pF	
COM ON capacitance	$C_{COM(ON)}$	$V_{COM} = 0\text{ V}$, $f = 1\text{ MHz}$, Switch ON, See Figure 16	25°C	5 V	13		pF	
Digital input capacitance	C_I	$V_I = 0\text{ V}$, See Figure 16	25°C	5 V	3		pF	
Bandwidth	BW	$R_L = 50\ \Omega$, Signal = 0 dBm, Switch ON, See Figure 18	25°C	5 V	450		MHz	
OFF isolation	O_{ISO}	$R_L = 50\ \Omega$, $V_{NO} = 1\text{ V}_{RMS}$ $f = 1\text{ MHz}$, $C_L = 5\text{ pF}$ Switch OFF, See Figure 19	25°C	5 V	-82		dB	
Total harmonic distortion	THD	$R_L = 600\ \Omega$, $C_L = 50\text{ pF}$, $V_{SOURCE} = 5\text{ V}_{p-p}$, $f = 20\text{ Hz to }20\text{ kHz}$, See Figure 21	25°C	5 V	0.04		%	
Supply								
Positive supply current	I_+	$V_I = V_+$ or GND, Switch ON or OFF	25°C	5.5 V	0.01	0.25	μA	
			Full	5.5 V	1			

(1) The algebraic convention, whereby the most negative value is a minimum and the most positive value is a maximum

Electrical Characteristics for 3-V Supply⁽¹⁾
 $V_+ = 2.7\text{ V to }3.6\text{ V}$, $T_A = -40^\circ\text{C to }85^\circ\text{C}$ (unless otherwise noted)

PARAMETER	SYMBOL	TEST CONDITIONS	T_A	V_+	MIN	TYP	MAX	UNIT
Analog Switch								
Analog signal range	V_{COM} , V_{NO}				0		V_+	V
ON-state resistance	r_{on}	$V_{NO} = 1.5\text{ V}$, $I_{COM} = 10\text{ mA}$,	Switch ON, See Figure 13	25°C Full	2.7 V	9.5	16 20	Ω
ON-state resistance flatness	$r_{on(Flat)}$	$V_{NO} = 1.5\text{ V}, 2.5\text{ V}$, $I_{COM} = 10\text{ mA}$,	Switch ON, See Figure 13	25°C Full	2.7 V	1.8	6 7	Ω
NO OFF leakage current	$I_{NO(OFF)}$	$V_{NO} = 1\text{ V}, V_{COM} = 3\text{ V}$, or $V_{NO} = 3\text{ V}, V_{COM} = 1\text{ V}$,	Switch OFF, See Figure 14	25°C Full	3.6 V	-0.5	0.01 0.5	nA
COM OFF leakage current	$I_{COM(OFF)}$	$V_{COM} = 1\text{ V}, V_{NO} = 3\text{ V}$, or $V_{COM} = 3\text{ V}, V_{NO} = 1\text{ V}$,	Switch OFF, See Figure 14	25°C Full	3.6 V	-0.5	0.01 0.5	nA
NO ON leakage current	$I_{NO(ON)}$	$V_{NO} = 1\text{ V}, V_{COM} = 1\text{ V}$, or $V_{NO} = 3\text{ V}, V_{COM} = 3\text{ V}$, or $V_{NO} = 1\text{ V}, 3\text{ V}, V_{COM} = \text{Open}$,	Switch ON, See Figure 15	25°C Full	3.6 V	-1	0.01 1	nA
COM ON leakage current	$I_{COM(ON)}$	$V_{COM} = 1\text{ V}, V_{NO} = 1\text{ V}$, or $V_{COM} = 3\text{ V}, V_{NO} = 3\text{ V}$, or $V_{COM} = 1\text{ V}, 3\text{ V}, V_{NO} = \text{Open}$,	Switch ON, See Figure 15	25°C Full	3.6 V	-1	0.01 1	nA
Digital Control Input (IN)								
Input logic high	V_{IH}			Full		2	5.5	V
Input logic low	V_{IL}			Full		0	0.8	V
Input leakage current	I_{IH}, I_{IL}	$V_I = V_+ \text{ or } 0$		25°C Full	3.6 V	-0.5	0.01 0.5	nA

⁽¹⁾ The algebraic convention, whereby the most negative value is a minimum and the most positive value is a maximum

TS5A4594 SINGLE-CHANNEL 8-Ω SPST ANALOG SWITCH

SCDS179 – FEBRUARY 2005

Electrical Characteristics for 3-V Supply⁽¹⁾ (continued)

$V_+ = 2.7\text{ V to }3.6\text{ V}$, $T_A = -40^\circ\text{C to }85^\circ\text{C}$ (unless otherwise noted)

PARAMETER	SYMBOL	TEST CONDITIONS	T_A	V_+	MIN	TYP	MAX	UNIT
Dynamic								
Turn-on time	t_{ON}	$V_{NO} = 2\text{ V}$, $R_L = 300\ \Omega$,	$C_L = 35\text{ pF}$, See Figure 17	25°C	3 V	20	30	ns
				Full	2.7 V to 3.6 V		35	
Turn-off time	t_{OFF}	$V_{COM} = 2\text{ V}$, $R_L = 300\ \Omega$,	$C_L = 35\text{ pF}$, See Figure 17	25°C	3 V	15	25	ns
				Full	2.7 V to 3.6 V		30	
Charge injection	Q_C	$V_{GEN} = 0$, $R_{GEN} = 0$, $C_L = 1\text{ nF}$,	See Figure 20	25°C	3 V	1	4	pC
NO OFF capacitance	$C_{NO(OFF)}$	$V_{NO} = 0\text{ V}$, $f = 1\text{ MHz}$,	Switch OFF, See Figure 16	25°C	3 V	6.5		pF
COM OFF capacitance	$C_{COM(OFF)}$	$V_{COM} = 0\text{ V}$, $f = 1\text{ MHz}$,	Switch OFF, See Figure 16	25°C	3 V	6.5		pF
NO ON capacitance	$C_{NO(ON)}$	$V_{NO} = 0\text{ V}$, $f = 1\text{ MHz}$,	Switch ON, See Figure 16	25°C	3 V	13		pF
COM ON capacitance	$C_{COM(ON)}$	$V_{COM} = 0\text{ V}$, $f = 1\text{ MHz}$,	Switch ON, See Figure 16	25°C	3 V	13		pF
Digital input capacitance	C_I	$V_I = 0\text{ V}$,	See Figure 16	25°C	3 V	3		pF
Bandwidth	BW	$R_L = 50\ \Omega$, Signal = 0 dBm	Switch ON, See Figure 18	25°C	3 V	450		MHz
OFF isolation	O_{ISO}	$R_L = 50\ \Omega$, $C_L = 5\text{ pF}$, $f = 1\text{ MHz}$, $V_{NO} = 1\text{ V}_{RMS}$,	Switch OFF, See Figure 19	25°C	3 V	-82		dB
Total harmonic distortion	THD	$R_L = 600\ \Omega$, $C_L = 50\text{ pF}$, $V_{SOURCE} = 3\text{ V}_{p-p}$	$f = 20\text{ Hz to }20\text{ kHz}$, See Figure 21	25°C	3 V	0.09		%
Supply								
Positive supply current	I_+	$V_I = V_+$ or GND,	Switch ON or OFF	25°C	5.5 V	0.01	0.25	μA
				Full			0.5	

(1) The algebraic convention, whereby the most negative value is a minimum and the most positive value is a maximum

TYPICAL PERFORMANCE

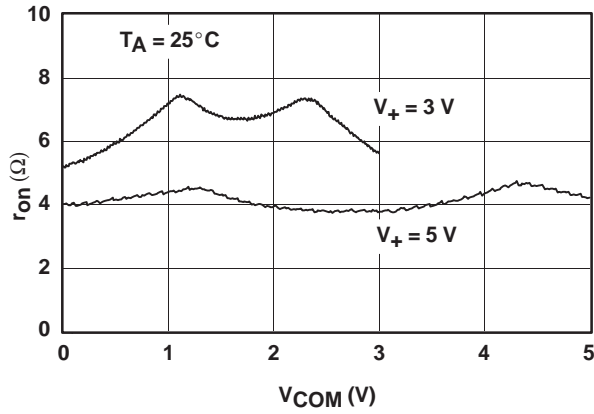

Figure 1. r_{on} vs V_{COM}

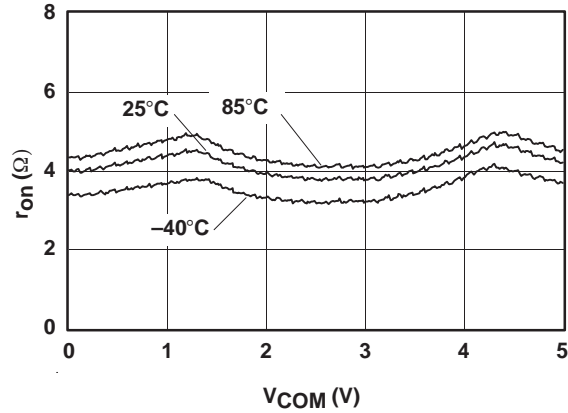

Figure 2. r_{on} vs V_{COM} ($V_+ = 5$ V)

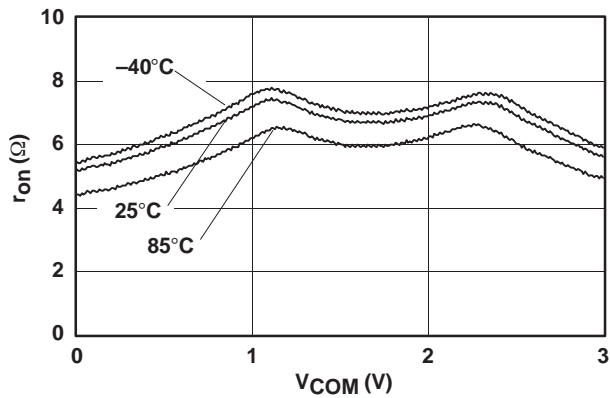

Figure 3. r_{on} vs V_{COM} ($V_+ = 3$ V)

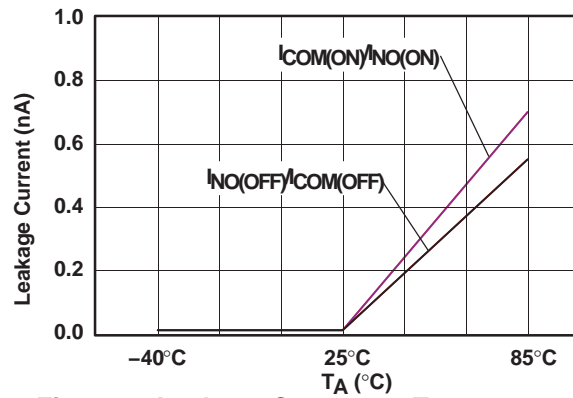

Figure 4. Leakage Current vs Temperature ($V_+ = 5$ V)

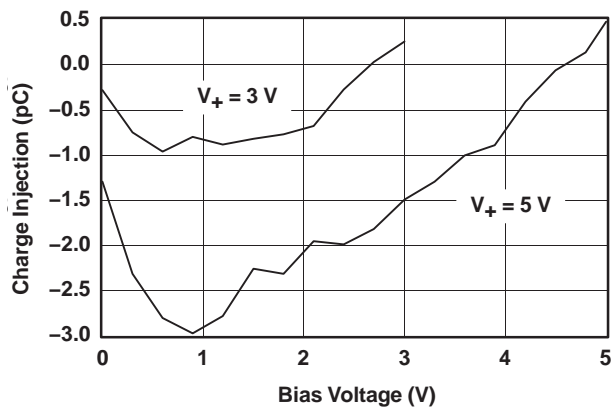

Figure 5. Charge-Injection (Q_C) vs V_{COM}

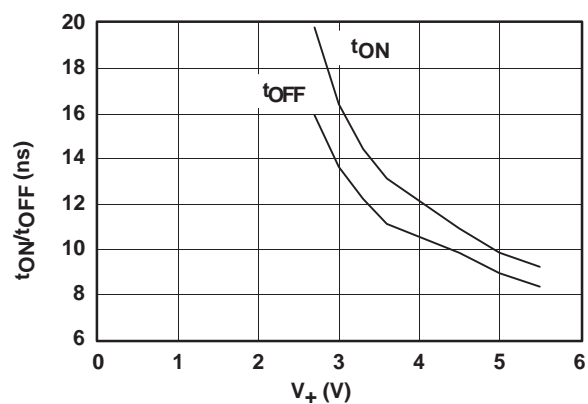

Figure 6. t_{ON} and t_{OFF} vs Supply Voltage

TYPICAL PERFORMANCE (continued)

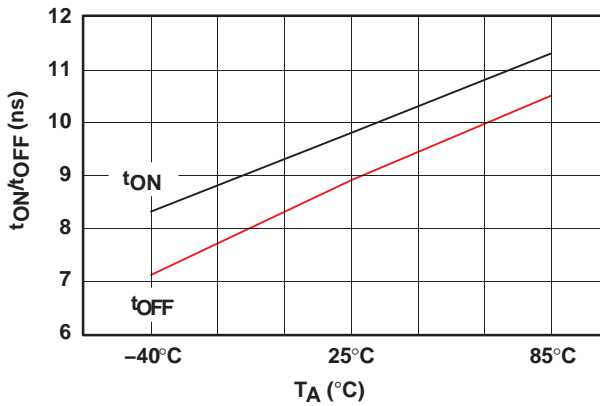

Figure 7. t_{ON} and t_{OFF} vs Temperature (V₊ = 5 V)

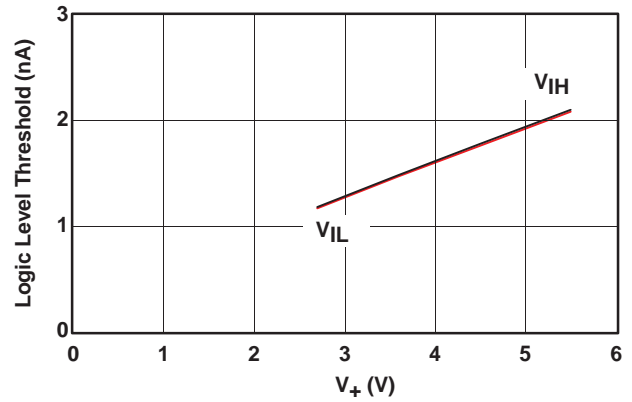

Figure 8. Logic-Level Threshold vs V₊

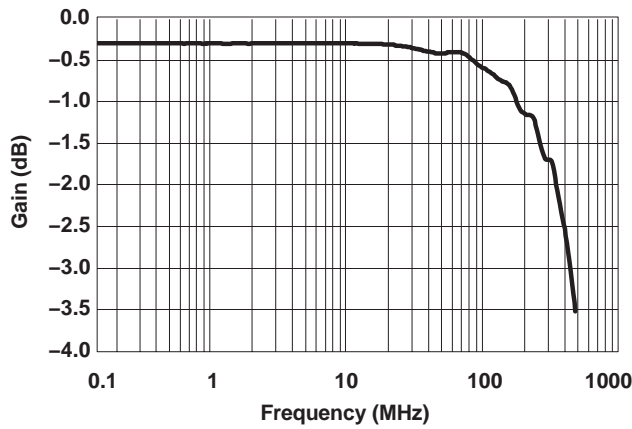

Figure 9. Bandwidth (Gain vs Frequency) (V₊ = 5 V)

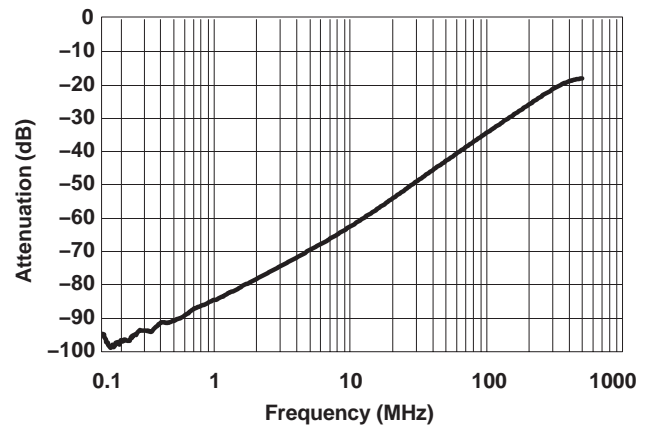

Figure 10. OFF Isolation vs Frequency

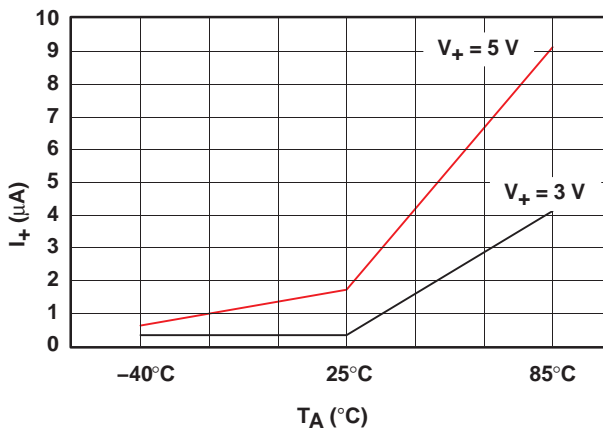

Figure 11. Power-Supply Current vs Temperature

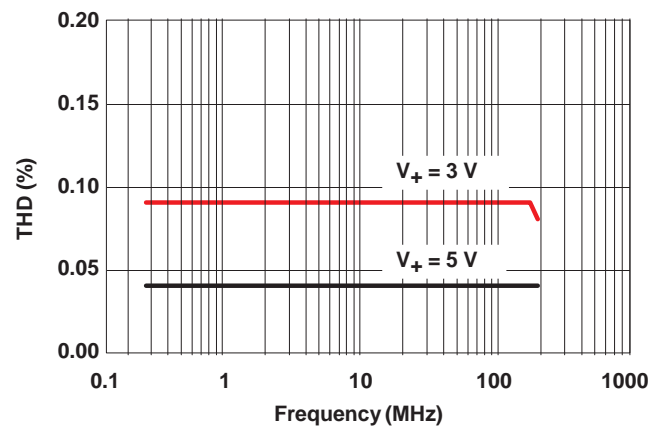

Figure 12. Total Harmonic Distortion vs Frequency

PIN DESCRIPTION

PIN NUMBER	NAME	DESCRIPTION
1	COM	Common
2	NO	Normally open
3	GND	Digital ground
4	IN	Digital control pin to connect COM to NO
5	V ₊	Power supply

PARAMETER DESCRIPTION

SYMBOL	DESCRIPTION
V _{COM}	Voltage at COM
V _{NO}	Voltage at NO
r _{on}	Resistance between COM and NO ports when the channel is ON
r _{on(flat)}	Difference between the maximum and minimum value of r _{on} in a channel over the specified range of conditions
I _{NO(OFF)}	Leakage current measured at the NO port, with the corresponding channel (NO to COM) in the OFF state
I _{NO(ON)}	Leakage current measured at the NO port, with the corresponding channel (NO to COM) in the ON state and the output (COM) open
I _{COM(OFF)}	Leakage current measured at the COM port, with the corresponding channel (COM to NO) in the OFF state
I _{COM(ON)}	Leakage current measured at the COM port, with the corresponding channel (COM to NO) in the ON state and the output (NO) open
V _{IH}	Minimum input voltage for logic high for the control input (IN)
V _{IL}	Maximum input voltage for logic low for the control input (IN)
V _I	Voltage at the control input (IN)
I _{IH} , I _{IL}	Leakage current measured at the control input (IN)
t _{ON}	Turn-on time for the switch. This parameter is measured under the specified range of conditions and by the propagation delay between the digital control (IN) signal and analog output (COM or NO) signal when the switch is turning ON.
t _{OFF}	Turn-off time for the switch. This parameter is measured under the specified range of conditions and by the propagation delay between the digital control (IN) signal and analog output (COM or NO) signal when the switch is turning OFF.
Q _C	Charge injection is a measurement of unwanted signal coupling from the control (IN) input to the analog (NO or COM) output. This is measured in coulomb (C) and measured by the total charge induced due to switching of the control input. Charge injection, $Q_C = C_L \times \Delta V_{COM}$, C _L is the load capacitance, and ΔV _{COM} is the change in analog output voltage.
C _{NO(OFF)}	Capacitance at the NO port when the corresponding channel (NO to COM) is OFF
C _{NO(ON)}	Capacitance at the NO port when the corresponding channel (NO to COM) is ON
C _{COM(OFF)}	Capacitance at the COM port when the corresponding channel (COM to NO) is OFF
C _{COM(ON)}	Capacitance at the COM port when the corresponding channel (COM to NO) is ON
C _I	Capacitance of control input (IN)
O _{ISO}	OFF isolation of the switch is a measurement of OFF-state switch impedance. This is measured in dB in a specific frequency, with the corresponding channel (NO to COM) in the OFF state.
BW	Bandwidth of the switch. This is the frequency in which the gain of an ON channel is –3 dB below the DC gain.
THD	Total harmonic distortion describes the signal distortion caused by the analog switch. This is defined as the ratio of root mean square (RMS) value of the second, third, and higher harmonic to the absolute magnitude of the fundamental harmonic.
I ₊	Static power-supply current with the control (IN) pin at V ₊ or GND

PARAMETER MEASUREMENT INFORMATION

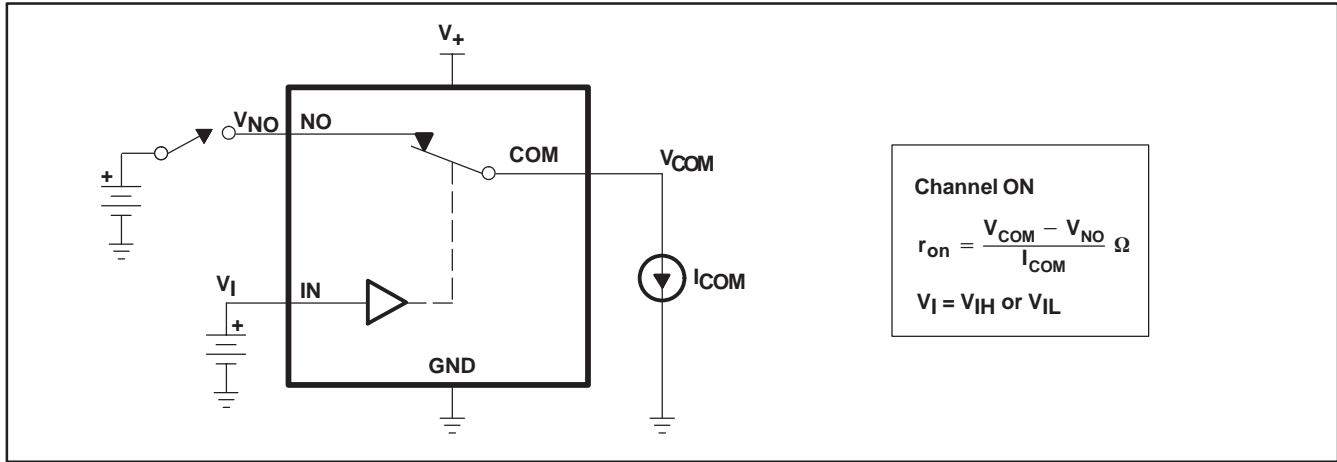

Figure 13. ON-State Resistance (r_{on})

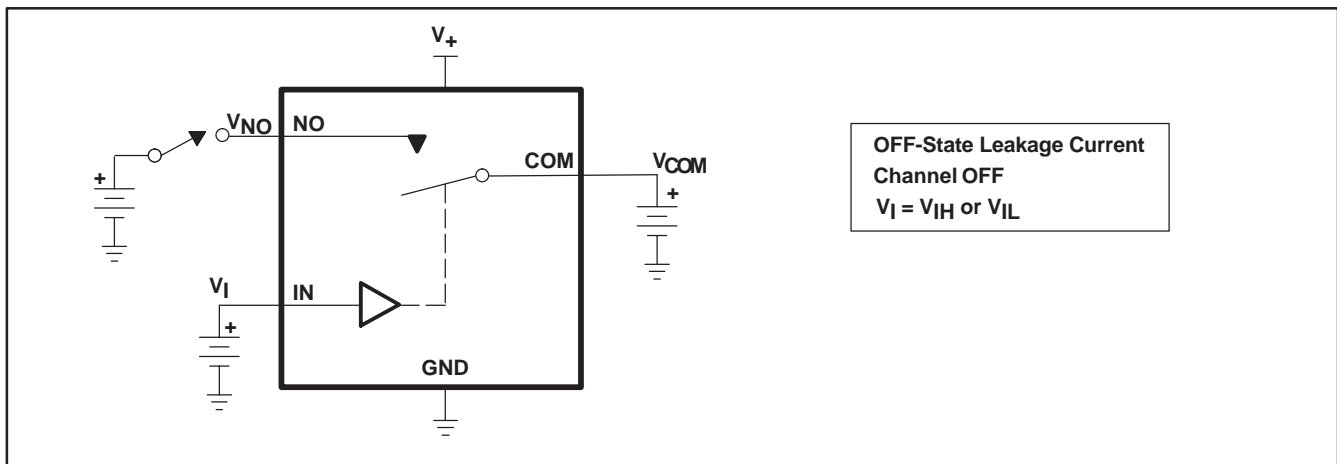

Figure 14. OFF-State Leakage Current ($I_{COM(OFF)}$, $I_{NO(OFF)}$)

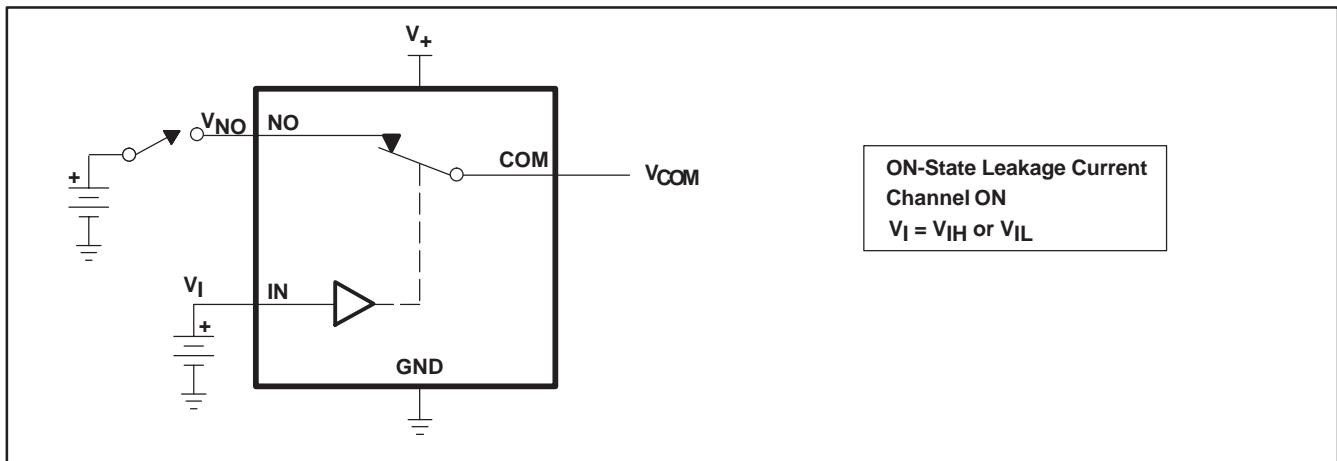

Figure 15. ON-State Leakage Current ($I_{COM(ON)}$, $I_{NO(ON)}$)

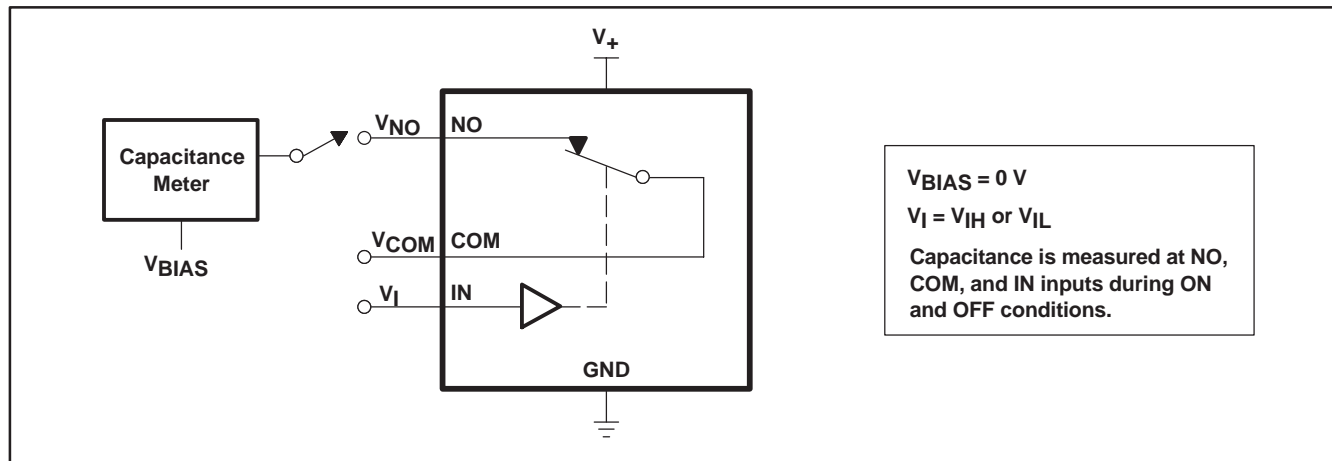
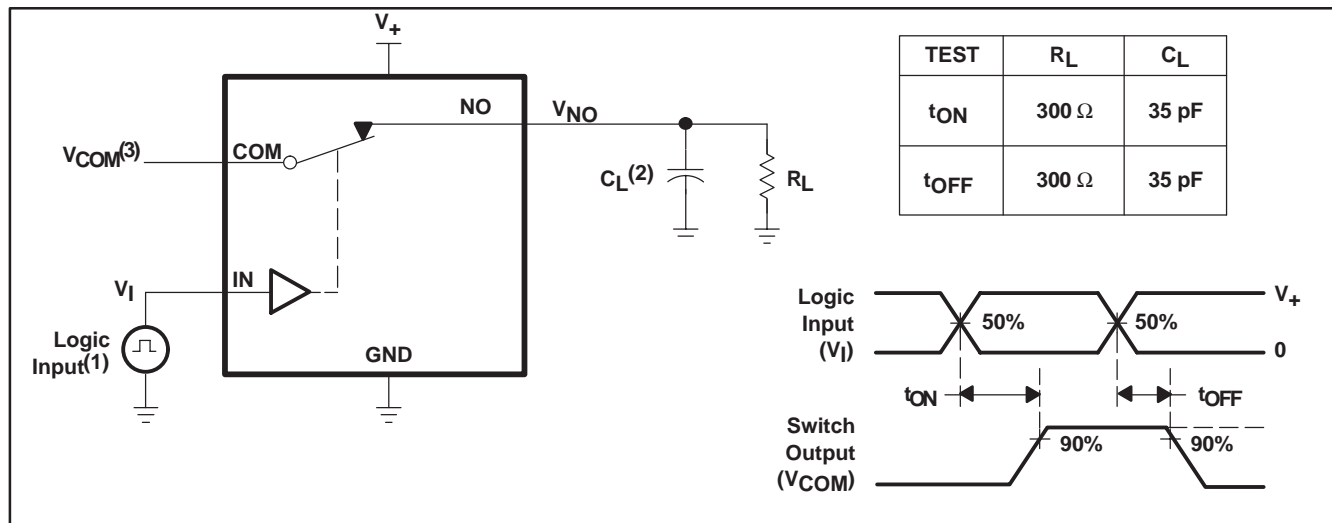

Figure 16. Capacitance (C_I , $C_{COM(OFF)}$, $C_{COM(ON)}$, $C_{NO(OFF)}$, $C_{NO(ON)}$)



- (1) All input pulses are supplied by generators having the following characteristics: PRR ≤ 10 MHz, $Z_O = 50 \Omega$, $t_r < 5 \text{ ns}$, $t_f < 5 \text{ ns}$.
 (2) C_L includes probe and jig capacitance.
 (3) See Electrical Characteristics for V_{COM} .

Figure 17. Turn-On (t_{ON}) and Turn-Off Time (t_{OFF})

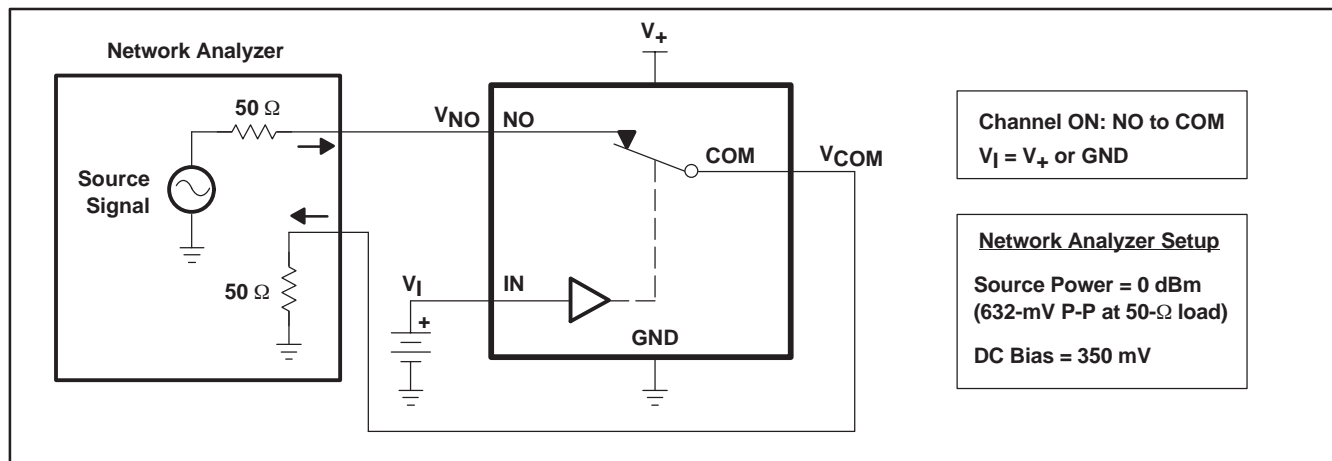

Figure 18. Bandwidth (BW)

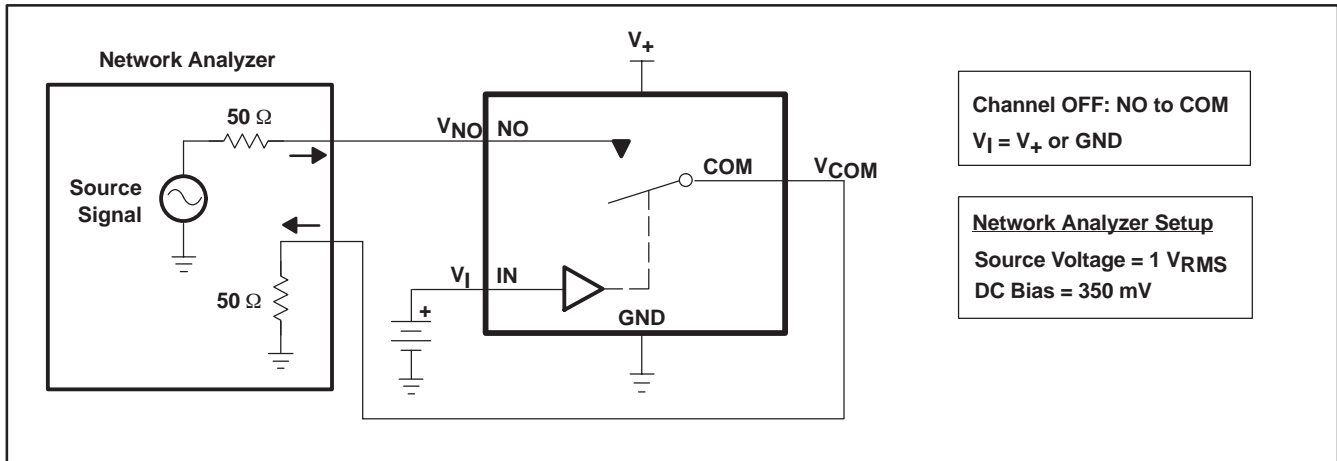
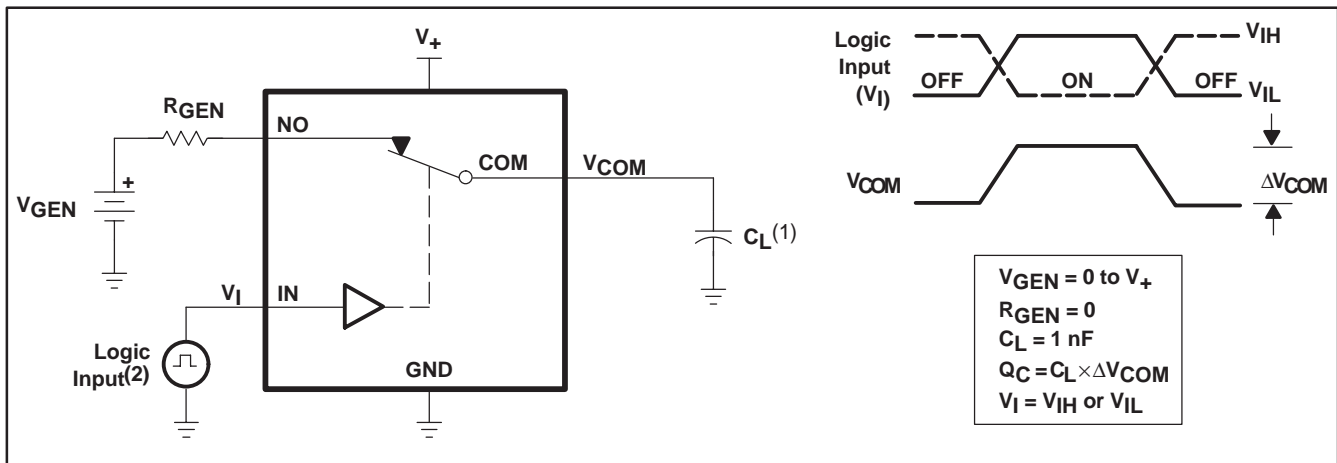

Figure 19. OFF Isolation (O_{ISO})



(1) C_L includes probe and jig capacitance.

(2) All input pulses are supplied by generators having the following characteristics: $PRR \leq 10$ MHz, $Z_O = 50 \Omega$, $t_r < 5$ ns, $t_f < 5$ ns.

Figure 20. Charge Injection (Q_C)

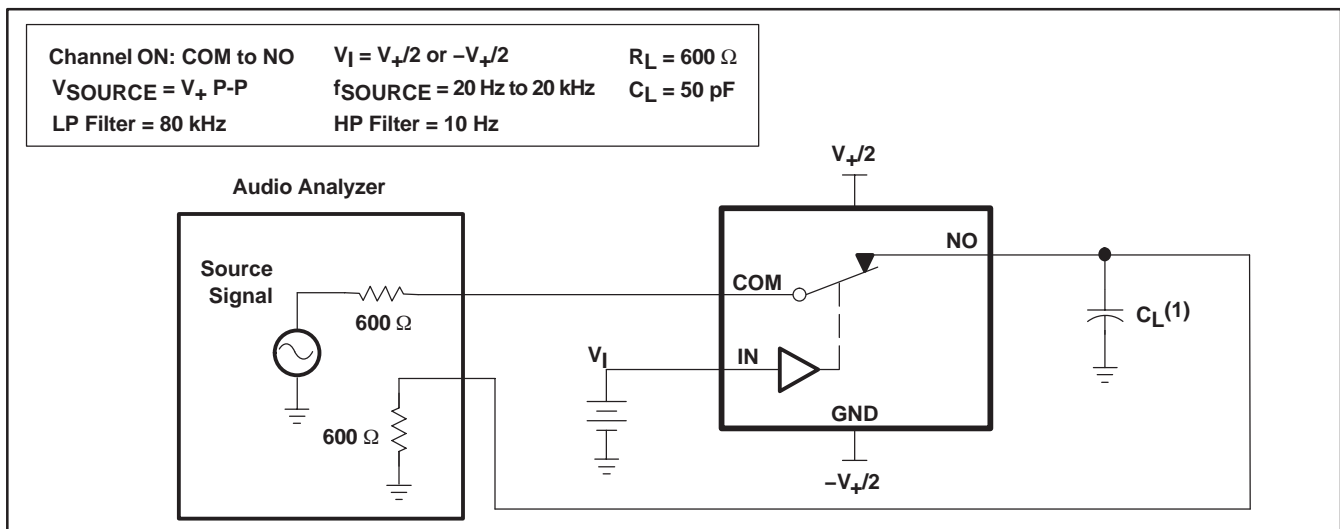

(1) C_L includes probe and jig capacitance.

Figure 21. Total Harmonic Distortion (THD)

PACKAGING INFORMATION

Orderable Device	Status ⁽¹⁾	Package Type	Package Drawing	Pins	Package Qty	Eco Plan ⁽²⁾	Lead/Ball Finish	MSL Peak Temp ⁽³⁾
TS5A4594DBVR	ACTIVE	SOT-23	DBV	5	3000	Green (RoHS & no Sb/Br)	CU NIPDAU	Level-1-260C-UNLIM
TS5A4594DBVRE4	ACTIVE	SOT-23	DBV	5	3000	Green (RoHS & no Sb/Br)	CU NIPDAU	Level-1-260C-UNLIM
TS5A4594DBVRG4	ACTIVE	SOT-23	DBV	5	3000	Green (RoHS & no Sb/Br)	CU NIPDAU	Level-1-260C-UNLIM
TS5A4594DCKR	ACTIVE	SC70	DCK	5	3000	Green (RoHS & no Sb/Br)	CU NIPDAU	Level-1-260C-UNLIM
TS5A4594DCKRE4	ACTIVE	SC70	DCK	5	3000	Green (RoHS & no Sb/Br)	CU NIPDAU	Level-1-260C-UNLIM
TS5A4594DCKRG4	ACTIVE	SC70	DCK	5	3000	Green (RoHS & no Sb/Br)	CU NIPDAU	Level-1-260C-UNLIM

⁽¹⁾ The marketing status values are defined as follows:

ACTIVE: Product device recommended for new designs.

LIFEBUY: TI has announced that the device will be discontinued, and a lifetime-buy period is in effect.

NRND: Not recommended for new designs. Device is in production to support existing customers, but TI does not recommend using this part in a new design.

PREVIEW: Device has been announced but is not in production. Samples may or may not be available.

OBSOLETE: TI has discontinued the production of the device.

⁽²⁾ Eco Plan - The planned eco-friendly classification: Pb-Free (RoHS), Pb-Free (RoHS Exempt), or Green (RoHS & no Sb/Br) - please check <http://www.ti.com/productcontent> for the latest availability information and additional product content details.

TBD: The Pb-Free/Green conversion plan has not been defined.

Pb-Free (RoHS): TI's terms "Lead-Free" or "Pb-Free" mean semiconductor products that are compatible with the current RoHS requirements for all 6 substances, including the requirement that lead not exceed 0.1% by weight in homogeneous materials. Where designed to be soldered at high temperatures, TI Pb-Free products are suitable for use in specified lead-free processes.

Pb-Free (RoHS Exempt): This component has a RoHS exemption for either 1) lead-based flip-chip solder bumps used between the die and package, or 2) lead-based die adhesive used between the die and leadframe. The component is otherwise considered Pb-Free (RoHS compatible) as defined above.

Green (RoHS & no Sb/Br): TI defines "Green" to mean Pb-Free (RoHS compatible), and free of Bromine (Br) and Antimony (Sb) based flame retardants (Br or Sb do not exceed 0.1% by weight in homogeneous material)

⁽³⁾ MSL, Peak Temp. -- The Moisture Sensitivity Level rating according to the JEDEC industry standard classifications, and peak solder temperature.

Important Information and Disclaimer:The information provided on this page represents TI's knowledge and belief as of the date that it is provided. TI bases its knowledge and belief on information provided by third parties, and makes no representation or warranty as to the accuracy of such information. Efforts are underway to better integrate information from third parties. TI has taken and continues to take reasonable steps to provide representative and accurate information but may not have conducted destructive testing or chemical analysis on incoming materials and chemicals. TI and TI suppliers consider certain information to be proprietary, and thus CAS numbers and other limited information may not be available for release.

In no event shall TI's liability arising out of such information exceed the total purchase price of the TI part(s) at issue in this document sold by TI to Customer on an annual basis.

TAPE AND REEL INFORMATION



QUADRANT ASSIGNMENTS FOR PIN 1 ORIENTATION IN TAPE



*All dimensions are nominal

Device	Package Type	Package Drawing	Pins	SPQ	Reel Diameter (mm)	Reel Width W1 (mm)	A0 (mm)	B0 (mm)	K0 (mm)	P1 (mm)	W (mm)	Pin1 Quadrant
TS5A4594DBVR	SOT-23	DBV	5	3000	180.0	9.2	3.23	3.17	1.37	4.0	8.0	Q3
TS5A4594DCKR	SC70	DCK	5	3000	180.0	9.2	2.24	2.34	1.22	4.0	8.0	Q3

TAPE AND REEL BOX DIMENSIONS



*All dimensions are nominal

Device	Package Type	Package Drawing	Pins	SPQ	Length (mm)	Width (mm)	Height (mm)
TS5A4594DBVR	SOT-23	DBV	5	3000	202.0	201.0	28.0
TS5A4594DCKR	SC70	DCK	5	3000	202.0	201.0	28.0

DBV (R-PDSO-G5)

PLASTIC SMALL-OUTLINE PACKAGE



- NOTES:
- A. All linear dimensions are in millimeters.
 - B. This drawing is subject to change without notice.
 - C. Body dimensions do not include mold flash or protrusion. Mold flash and protrusion shall not exceed 0.15 per side.
 - D. Falls within JEDEC MO-178 Variation AA.

DCK (R-PDSO-G5)

PLASTIC SMALL-OUTLINE PACKAGE



- NOTES:
- A. All linear dimensions are in millimeters.
 - B. This drawing is subject to change without notice.
 - C. Body dimensions do not include mold flash or protrusion. Mold flash and protrusion shall not exceed 0.15 per side.
 - D. Falls within JEDEC MO-203 variation AA.

IMPORTANT NOTICE

Texas Instruments Incorporated and its subsidiaries (TI) reserve the right to make corrections, modifications, enhancements, improvements, and other changes to its products and services at any time and to discontinue any product or service without notice. Customers should obtain the latest relevant information before placing orders and should verify that such information is current and complete. All products are sold subject to TI's terms and conditions of sale supplied at the time of order acknowledgment.

TI warrants performance of its hardware products to the specifications applicable at the time of sale in accordance with TI's standard warranty. Testing and other quality control techniques are used to the extent TI deems necessary to support this warranty. Except where mandated by government requirements, testing of all parameters of each product is not necessarily performed.

TI assumes no liability for applications assistance or customer product design. Customers are responsible for their products and applications using TI components. To minimize the risks associated with customer products and applications, customers should provide adequate design and operating safeguards.

TI does not warrant or represent that any license, either express or implied, is granted under any TI patent right, copyright, mask work right, or other TI intellectual property right relating to any combination, machine, or process in which TI products or services are used. Information published by TI regarding third-party products or services does not constitute a license from TI to use such products or services or a warranty or endorsement thereof. Use of such information may require a license from a third party under the patents or other intellectual property of the third party, or a license from TI under the patents or other intellectual property of TI.

Reproduction of TI information in TI data books or data sheets is permissible only if reproduction is without alteration and is accompanied by all associated warranties, conditions, limitations, and notices. Reproduction of this information with alteration is an unfair and deceptive business practice. TI is not responsible or liable for such altered documentation. Information of third parties may be subject to additional restrictions.

Resale of TI products or services with statements different from or beyond the parameters stated by TI for that product or service voids all express and any implied warranties for the associated TI product or service and is an unfair and deceptive business practice. TI is not responsible or liable for any such statements.

TI products are not authorized for use in safety-critical applications (such as life support) where a failure of the TI product would reasonably be expected to cause severe personal injury or death, unless officers of the parties have executed an agreement specifically governing such use. Buyers represent that they have all necessary expertise in the safety and regulatory ramifications of their applications, and acknowledge and agree that they are solely responsible for all legal, regulatory and safety-related requirements concerning their products and any use of TI products in such safety-critical applications, notwithstanding any applications-related information or support that may be provided by TI. Further, Buyers must fully indemnify TI and its representatives against any damages arising out of the use of TI products in such safety-critical applications.

TI products are neither designed nor intended for use in military/aerospace applications or environments unless the TI products are specifically designated by TI as military-grade or "enhanced plastic." Only products designated by TI as military-grade meet military specifications. Buyers acknowledge and agree that any such use of TI products which TI has not designated as military-grade is solely at the Buyer's risk, and that they are solely responsible for compliance with all legal and regulatory requirements in connection with such use.

TI products are neither designed nor intended for use in automotive applications or environments unless the specific TI products are designated by TI as compliant with ISO/TS 16949 requirements. Buyers acknowledge and agree that, if they use any non-designated products in automotive applications, TI will not be responsible for any failure to meet such requirements.

Following are URLs where you can obtain information on other Texas Instruments products and application solutions:

Products

Amplifiers	amplifier.ti.com
Data Converters	dataconverter.ti.com
DLP® Products	www.dlp.com
DSP	dsp.ti.com
Clocks and Timers	www.ti.com/clocks
Interface	interface.ti.com
Logic	logic.ti.com
Power Mgmt	power.ti.com
Microcontrollers	microcontroller.ti.com
RFID	www.ti-rfid.com
RF/IF and ZigBee® Solutions	www.ti.com/lprf

Applications

Audio	www.ti.com/audio
Automotive	www.ti.com/automotive
Broadband	www.ti.com/broadband
Digital Control	www.ti.com/digitalcontrol
Medical	www.ti.com/medical
Military	www.ti.com/military
Optical Networking	www.ti.com/opticalnetwork
Security	www.ti.com/security
Telephony	www.ti.com/telephony
Video & Imaging	www.ti.com/video
Wireless	www.ti.com/wireless

Mailing Address: Texas Instruments, Post Office Box 655303, Dallas, Texas 75265
Copyright © 2009, Texas Instruments Incorporated