

FEATURES

- Low ON-State Resistance (10 Ω)
- Control Inputs Are 5-V Tolerant
- Low Charge Injection
- Excellent ON-State Resistance Matching
- Low Total Harmonic Distortion (THD)
- 1.65-V to 5.5-V Single-Supply Operation
- Latch-Up Performance Exceeds 100 mA Per JESD 78, Class II
- ESD Performance Tested Per JESD 22
 - 2000-V Human-Body Model (A114-B, Class II)
 - 1000-V Charged-Device Model (C101)

APPLICATIONS

- Sample-and-Hold Circuits
- Battery-Powered Equipment
- Audio and Video Signal Routing
- Communication Circuits

SOT-23 OR SC-70 PACKAGE
(TOP VIEW)

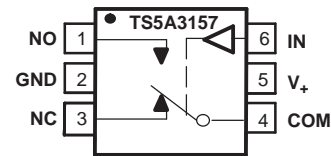

YZP PACKAGE
(BOTTOM VIEW)

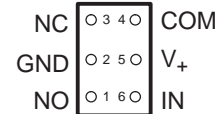

DESCRIPTION/ORDERING INFORMATION

The TS5A3157 is a single-pole double-throw (SPDT) analog switch that is designed to operate from 1.65 V to 5.5 V. This device can handle both digital and analog signals, and signals up to V_+ can be transmitted in either direction.

SUMMARY OF CHARACTERISTICS⁽¹⁾

Configuration	Single Pole Double Throw (SPDT)
Number of channels	1
ON-state resistance (r_{on})	10 Ω
ON-state resistance match (Δr_{on})	0.15 Ω
ON-state resistance flatness ($r_{on(flat)}$)	4 Ω
Turn-on/turn-off time (t_{ON}/t_{OFF})	5.7 ns/3.8 ns
Break-before-make time (t_{BBM})	0.5 ns
Charge injection (Q_C)	7 pC
Bandwidth (BW)	300 MHz
OFF isolation (O_{ISO})	-65 dB at 10 MHz
Crosstalk (X_{TALK})	-66 dB at 10 MHz
Total harmonic distortion (THD)	0.01%
Leakage current ($I_{NO(OFF)}/I_{NC(OFF)}$)	±0.1 μA
Power-supply current (I_+)	10 μA
Package options	6-pin DSBGA, DBV, or DCK

(1) $V_+ = 5\text{ V}$ and $T_A = 25^\circ\text{C}$



Please be aware that an important notice concerning availability, standard warranty, and use in critical applications of Texas Instruments semiconductor products and disclaimers thereto appears at the end of this data sheet.

NanoFree is a trademark of Texas Instruments.

TS5A3157

10-Ω SPDT ANALOG SWITCH

SCDS219A–NOVEMBER 2005–REVISED OCTOBER 2007

ORDERING INFORMATION

T _A	PACKAGE ⁽¹⁾		ORDERABLE PART NUMBER	TOP-SIDE MARKING ⁽²⁾
–40°C to 85°C	NanoFree™ – WCSP (DSBGA) 0.23-mm Large Bump – YZP (Pb-free)	Tape and reel	TS5A3157YZPR	___JC_
	SOT (SOT-23) – DBV	Tape and reel	TS5A3157DBVR	JC5_
	SOT (SC-70) – DCK	Tape and reel	TS5A3157DCKR	JC_

- Package drawings, standard packing quantities, thermal data, symbolization, and PCB design guidelines are available at www.ti.com/sc/package.
- DBV/DCK: The actual top-side marking has one additional character that designates the assembly/test site.
YZP: The actual top-side marking has three preceding characters to denote year, month, and sequence code, and one following character to designate the assembly/test site. Pin 1 identifier indicates solder-bump composition (1 = SnPb, • = Pb-free).

FUNCTION TABLE

IN	NC TO COM, COM TO NC	NO TO COM, COM TO NO
L	ON	OFF
H	OFF	ON

Absolute Minimum and Maximum Ratings⁽¹⁾⁽²⁾

over operating free-air temperature range (unless otherwise noted)

		MIN	MAX	UNIT		
V ₊	Supply voltage range ⁽³⁾	–0.5	6.5	V		
V _{NO} V _{NC} V _{COM}	Analog voltage range ⁽³⁾⁽⁴⁾⁽⁵⁾	–0.5	V ₊ + 0.5	V		
I _K	Analog port diode current	V _{NC} , V _{NO} , V _{COM} < 0 or V _{NO} , V _{NC} , V _{COM} > V ₊		–50	50	mA
I _{NO} I _{NC} I _{COM}	On-state switch current	V _{NC} , V _{NO} , V _{COM} = 0 to V ₊		–50	50	mA
V _I	Digital input voltage range ⁽³⁾⁽⁴⁾	–0.5	6.5	V		
I _{IK}	Digital input clamp current	V _I < 0		–50		mA
I ₊	Continuous current through V ₊	–100	100	mA		
I _{GND}	Continuous current through GND	–100	100	mA		
θ _{JA}	Package thermal impedance ⁽⁶⁾	DBV package			206	°C/W
		DCK package			252	
		YZP package			132	
T _{stg}	Storage temperature range	–65	150	°C		

- Stresses above these ratings may cause permanent damage. Exposure to absolute maximum conditions for extended periods may degrade device reliability. These are stress ratings only, and functional operation of the device at these or any other conditions beyond those specified is not implied.
- The algebraic convention, whereby the most negative value is a minimum and the most positive value is a maximum
- All voltages are with respect to ground, unless otherwise specified.
- The input and output voltage ratings may be exceeded if the input and output clamp-current ratings are observed.
- This value is limited to 5.5 V maximum.
- The package thermal impedance is calculated in accordance with JESD 51-7.

Electrical Characteristics for 5-V Supply⁽¹⁾

$V_+ = 4.5 \text{ V to } 5.5 \text{ V}$, $T_A = -40^\circ\text{C to } 85^\circ\text{C}$ (unless otherwise noted)

PARAMETER	SYMBOL	TEST CONDITIONS	T_A	V_+	MIN	TYP	MAX	UNIT
Analog Switch								
Analog signal range	V_{COM}, V_{NO}, V_{NC}				0		V_+	V
ON-state resistance	r_{on}	$0 \leq (V_{NO} \text{ or } V_{NC}) \leq V_+$, $I_{COM} = -30 \text{ mA}$, Switch ON, See Figure 13	25°C	4.5 V		5.5	10	Ω
			Full					
ON-state resistance match between channels	Δr_{on}	$V_{NO} \text{ or } V_{NC} = 3.15 \text{ V}$, $I_{COM} = -30 \text{ mA}$, Switch ON, See Figure 13	25°C	4.5 V		0.15	0.2	Ω
			Full					
ON-state resistance flatness	$r_{on(flat)}$	$0 \leq (V_{NO} \text{ or } V_{NC}) \leq V_+$, $I_{COM} = -30 \text{ mA}$, Switch ON, See Figure 13	25°C	4.5 V		4	5	Ω
			Full					
NO, NC OFF leakage current	$I_{NO(OFF)}, I_{NC(OFF)}$	$V_{NO} \text{ or } V_{NC} = 1 \text{ V}$, $V_{COM} = 4.5 \text{ V}$, or $V_{NO} \text{ or } V_{NC} = 4.5 \text{ V}$, $V_{COM} = 1 \text{ V}$, Switch OFF, See Figure 14	25°C	5.5 V		-0.1	0.05	0.1
			Full					
NO, NC ON leakage current	$I_{NO(ON)}, I_{NC(ON)}$	$V_{NO} = 1 \text{ V}$, $V_{COM} = \text{Open}$, or $V_{NO} = 4.5 \text{ V}$, $V_{COM} = \text{Open}$, Switch ON, See Figure 15	25°C	5.5 V		-0.1	0.05	0.1
			Full					
COM ON leakage current	$I_{COM(ON)}$	$V_{COM} = 1 \text{ V}$, $V_{NO} \text{ or } V_{NC} = \text{Open}$, or $V_{COM} = 4.5 \text{ V}$, $V_{NO} \text{ or } V_{NC} = \text{Open}$, Switch ON, See Figure 15	25°C	5.5 V		-0.1	0.05	0.1
			Full					
Digital Control Input (IN)								
Input logic high	V_{IH}		Full			$V_+ \times 0.7$	5.5	V
Input logic low	V_{IL}		Full		0		$V_+ \times 0.3$	V
Input leakage current	I_{IH}, I_{IL}	$V_I = 5.5 \text{ V or } 0$	25°C	5.5 V		-0.1	0.05	0.1
			Full					

(1) The algebraic convention, whereby the most negative value is a minimum and the most positive value is a maximum.

TS5A3157

10-Ω SPDT ANALOG SWITCH

SCDS219A–NOVEMBER 2005–REVISED OCTOBER 2007

Electrical Characteristics for 5-V Supply⁽¹⁾ (Continued)

$V_+ = 4.5\text{ V to }5.5\text{ V}$, $T_A = -40^\circ\text{C to }85^\circ\text{C}$ (unless otherwise noted)

PARAMETER	SYMBOL	TEST CONDITIONS	T_A	V_+	MIN	TYP	MAX	UNIT	
Dynamic									
Turn-on time	t_{ON}	$V_{COM} = 3\text{ V}$, $R_L = 300\ \Omega$,	$C_L = 35\text{ pF}$, See Figure 17	25°C	5 V	1	6	8.5	ns
				Full	4.5 V to 5.5 V	1		9.5	
Turn-off time	t_{OFF}	$V_{COM} = 3\text{ V}$, $R_L = 300\ \Omega$,	$C_L = 35\text{ pF}$, See Figure 17	25°C	5 V	1	3.5	6.5	ns
				Full	4.5 V to 5.5 V	1		7.5	
Break-before-make time	t_{BBM}	$V_{NO} = V_{NC} = V_+/2$, $R_L = 50\ \Omega$,	$C_L = 35\text{ pF}$, See Figure 18	25°C	5 V	1.8	2	3	ns
				Full	4.5 V to 5.5 V	1.8		3.5	
Charge injection	Q_C	$V_{GEN} = 0$, $R_{GEN} = 0$,	$C_L = 0.1\text{ nF}$, See Figure 22	25°C	5 V		7	pC	
NO, NC OFF capacitance	$C_{NO(OFF)}$, $C_{NC(OFF)}$	V_{NO} or $V_{NC} = V_+$ or GND, Switch OFF,	See Figure 16	25°C	5 V		5.5	pF	
NO, NC ON capacitance	$C_{NO(ON)}$, $C_{NC(ON)}$	V_{NO} or $V_{NC} = V_+$ or GND, Switch ON,	See Figure 16	25°C	5 V		17.5	pF	
COM ON capacitance	$C_{COM(ON)}$	$V_{COM} = V_+$ or GND, Switch ON,	See Figure 16	25°C	5 V		17.5	pF	
Digital input capacitance	C_I	$V_I = V_+$ or GND,	See Figure 16	25°C	5 V		2.8	pF	
Bandwidth	BW	$R_L = 50\ \Omega$, Switch ON,	See Figure 19	25°C	5 V		300	MHz	
OFF isolation	O_{ISO}	$R_L = 50\ \Omega$, $f = 10\text{ MHz}$,	Switch OFF, See Figure 20	25°C	5 V		-65	dB	
Crosstalk	X_{TALK}	$R_L = 50\ \Omega$, $f = 10\text{ MHz}$,	Switch ON, See Figure 21	25°C	5 V		-66	dB	
Total harmonic distortion	THD	$R_L = 600\ \Omega$, $C_L = 50\text{ pF}$,	$f = 20\text{ Hz to }20\text{ kHz}$, See Figure 23	25°C	5 V		0.01	%	
Supply									
Positive supply current	I_+	$V_I = V_+$ or GND,	Switch ON or OFF	25°C	5.5 V		2.5	5	μA
				Full				10	

(1) The algebraic convention, whereby the most negative value is a minimum and the most positive value is a maximum.

Electrical Characteristics for 3.3-V Supply⁽¹⁾

$V_+ = 3\text{ V to }3.6\text{ V}$, $T_A = -40^\circ\text{C to }85^\circ\text{C}$ (unless otherwise noted)

PARAMETER	SYMBOL	TEST CONDITIONS	T_A	V_+	MIN	TYP	MAX	UNIT
Analog Switch								
Analog signal range	V_{COM}, V_{NO}, V_{NC}				0		V_+	V
ON-state resistance	r_{on}	$0 \leq (V_{NO} \text{ or } V_{NC}) \leq V_+$, $I_{COM} = -24\text{ mA}$, Switch ON, See Figure 13	25°C	3 V		12	20	Ω
			Full				20	
ON-state resistance match between channels	Δr_{on}	$V_{NO} \text{ or } V_{NC} = 2.1\text{ V}$, $I_{COM} = -24\text{ mA}$, Switch ON, See Figure 13	25°C	3 V		0.2	0.4	Ω
			Full				0.3	
ON-state resistance flatness	$r_{on(Flat)}$	$0 \leq (V_{NO} \text{ or } V_{NC}) \leq V_+$, $I_{COM} = -24\text{ mA}$, Switch ON, See Figure 13	25°C	3 V		9	11	Ω
			Full				12	
NO, NC OFF leakage current	$I_{NO(OFF)}, I_{NC(OFF)}$	$V_{NO} \text{ or } V_{NC} = 1\text{ V}$, $V_{COM} = 3\text{ V}$, or $V_{NO} \text{ or } V_{NC} = 3\text{ V}$, $V_{COM} = 1\text{ V}$, Switch OFF, See Figure 14	25°C	3.6 V	-0.1	0.05	0.1	μA
			Full		-0.2	0.1	0.2	
NO, NC ON leakage current	$I_{NO(ON)}, I_{NC(ON)}$	$V_{NO} \text{ or } V_{NC} = 1\text{ V}$, $V_{COM} = \text{Open}$, or $V_{NO} \text{ or } V_{NC} = 3\text{ V}$, $V_{COM} = \text{Open}$, Switch ON, See Figure 15	25°C	3.6 V	-0.1	0.05	0.1	μA
			Full		-0.2	0.1	0.2	
COM ON leakage current	$I_{COM(ON)}$	$V_{COM} = 1\text{ V}$, $V_{NO} \text{ or } V_{NC} = \text{Open}$, or $V_{COM} = 3\text{ V}$, $V_{NO} \text{ or } V_{NC} = \text{Open}$, Switch ON, See Figure 15	25°C	3.6 V	-0.1	0.05	0.1	μA
			Full		-0.2	0.1	0.2	
Digital Control Input (IN)								
Input logic high	V_{IH}		Full		$V_+ \times 0.7$		5.5	V
Input logic low	V_{IL}		Full		0		$V_+ \times 0.3$	V
Input leakage current	I_{IH}, I_{IL}	$V_I = 5.5\text{ V or }0$	25°C	3.6 V	-0.1	0.05	0.1	μA
			Full		-1		1	

(1) The algebraic convention, whereby the most negative value is a minimum and the most positive value is a maximum.

TS5A3157

10-Ω SPDT ANALOG SWITCH

SCDS219A–NOVEMBER 2005–REVISED OCTOBER 2007

Electrical Characteristics for 3.3-V Supply⁽¹⁾ (Continued)

$V_+ = 3\text{ V to }3.6\text{ V}$, $T_A = -40^\circ\text{C to }85^\circ\text{C}$ (unless otherwise noted)

PARAMETER	SYMBOL	TEST CONDITIONS	T_A	V_+	MIN	TYP	MAX	UNIT	
Dynamic									
Turn-on time	t_{ON}	$V_{COM} = 2\text{ V}$, $R_L = 300\ \Omega$,	$C_L = 35\text{ pF}$, See Figure 17	25°C	3.3 V	3.5	7	9.5	ns
				Full	3 V to 3.6 V	1.5		10.5	
Turn-off time	t_{OFF}	$V_{COM} = 2\text{ V}$, $R_L = 300\ \Omega$,	$C_L = 35\text{ pF}$, See Figure 17	25°C	3.3 V	1	3.5	6.5	ns
				Full	3 V to 3.6 V	1		7.5	
Break-before-make time	t_{BBM}	$V_{NC} = V_{NO} = V_+/2$, $R_L = 50\ \Omega$,	$C_L = 35\text{ pF}$, See Figure 18	25°C	3.3 V	2.5	3	5	ns
				Full	3 V to 3.6 V	2		5	
Charge injection	Q_C	$V_{GEN} = 0$, $R_{GEN} = 0$,	$C_L = 0.1\text{ nF}$, See Figure 22	25°C	3.3 V		3	pC	
NO, NC OFF capacitance	$C_{NO(OFF)}$	V_{NO} or $V_{NC} = V_+$ or GND, Switch OFF,	See Figure 16	25°C	3.3 V		5.5	pF	
NO, NC ON capacitance	$C_{NO(ON)}$	V_{NO} or $V_{NC} = V_+$ or GND, Switch ON,	See Figure 16	25°C	3.3 V		17.5	pF	
COM ON capacitance	$C_{COM(ON)}$	$V_{COM} = V_+$ or GND, Switch ON,	See Figure 16	25°C	3.3 V		17.5	pF	
Digital input capacitance	C_I	$V_I = V_+$ or GND,	See Figure 16	25°C	3.3 V		2.8	pF	
Bandwidth	BW	$R_L = 50\ \Omega$, Switch ON,	See Figure 19	25°C	3.3 V		300	MHz	
OFF isolation	O_{ISO}	$R_L = 50\ \Omega$, $f = 10\text{ MHz}$,	Switch OFF, See Figure 20	25°C	3.3 V		-65	dB	
Crosstalk	X_{TALK}	$R_L = 50\ \Omega$, $f = 10\text{ MHz}$,	Switch ON, See Figure 21	25°C	3.3 V		-66	dB	
Total harmonic distortion	THD	$R_L = 600\ \Omega$, $C_L = 50\text{ pF}$,	$f = 20\text{ Hz to }20\text{ kHz}$, See Figure 23	25°C	3.3 V		0.015	%	
Supply									
Positive supply current	I_+	$V_I = V_+$ or GND,	Switch ON or OFF	25°C	3.6 V		2.5	5	μA
				Full				10	

(1) The algebraic convention, whereby the most negative value is a minimum and the most positive value is a maximum.

Electrical Characteristics for 2.5-V Supply⁽¹⁾

$V_+ = 2.3 \text{ V to } 2.7 \text{ V}$, $T_A = -40^\circ\text{C to } 85^\circ\text{C}$ (unless otherwise noted)

PARAMETER	SYMBOL	TEST CONDITIONS	T_A	V_+	MIN	TYP	MAX	UNIT	
Analog Switch									
Analog signal range	V_{COM}, V_{NO}, V_{NC}				0		V_+	V	
ON-state resistance	r_{on}	$0 \leq (V_{NO} \text{ or } V_{NC}) \leq V_+$, $I_{COM} = -8 \text{ mA}$,	Switch ON, See Figure 13	25°C	2.3 V	35	45	Ω	
				Full		50			
ON-state resistance match between channels	Δr_{on}	$V_{NO} \text{ or } V_{NC} = 1.6 \text{ V}$, $I_{COM} = -8 \text{ mA}$,	Switch ON, See Figure 13	25°C	2.3 V	0.3	0.5	Ω	
				Full		0.7			
ON-state resistance flatness	$r_{on(flat)}$	$0 \leq (V_{NO} \text{ or } V_{NC}) \leq V_+$, $I_{COM} = -8 \text{ mA}$,	Switch ON, See Figure 13	25°C	2.3 V	30	40	Ω	
				Full		40			
NO, NC OFF leakage current	$I_{NO(OFF)}, I_{NC(OFF)}$	$V_{NO} \text{ or } V_{NC} = 0.5 \text{ V}$, $V_{COM} = 2.2 \text{ V}$, or $V_{NO} \text{ or } V_{NC} = 2.2 \text{ V}$, $V_{COM} = 0.5 \text{ V}$,	Switch OFF, See Figure 14	25°C	2.7 V	-0.1	0.05	0.1	μA
				Full		-0.2	0.1	0.2	
NO, NC ON leakage current	$I_{NO(ON)}, I_{NC(ON)}$	$V_{NO} \text{ or } V_{NC} = 0.5 \text{ V}$, $V_{COM} = \text{Open}$, or $V_{NO} \text{ or } V_{NC} = 2.2 \text{ V}$, $V_{COM} = \text{Open}$,	Switch ON, See Figure 15	25°C	2.7 V	-0.1	0.05	0.1	μA
				Full		-0.2	0.1	0.2	
COM ON leakage current	$I_{COM(ON)}$	$V_{COM} = 0.5 \text{ V}$, $V_{NO} \text{ or } V_{NC} = \text{Open}$, or $V_{COM} = 2.2 \text{ V}$, $V_{NO} \text{ or } V_{NC} = \text{Open}$,	Switch ON, See Figure 15	25°C	2.7 V	-0.1	0.05	0.1	μA
				Full		-0.2	0.1	0.2	
Digital Control Input (IN)									
Input logic high	V_{IH}		Full		$V_+ \times 0.7$		5.5	V	
Input logic low	V_{IL}		Full		0		$V_+ \times 0.3$	V	
Input leakage current	I_{IH}, I_{IL}	$V_I = 5.5 \text{ V or } 0$	25°C	2.7 V	-0.1	0.05	0.1	μA	
			Full		-1	1			

(1) The algebraic convention, whereby the most negative value is a minimum and the most positive value is a maximum.

TS5A3157

10-Ω SPDT ANALOG SWITCH

SCDS219A–NOVEMBER 2005–REVISED OCTOBER 2007

Electrical Characteristics for 2.5-V Supply⁽¹⁾ (Continued)

$V_+ = 2.3 \text{ V to } 2.7 \text{ V}$, $T_A = -40^\circ\text{C to } 85^\circ\text{C}$ (unless otherwise noted)

PARAMETER	SYMBOL	TEST CONDITIONS	T_A	V_+	MIN	TYP	MAX	UNIT
Dynamic								
Turn-on time	t_{ON}	$V_{COM} = 1.5 \text{ V}$, $R_L = 300 \Omega$, $C_L = 35 \text{ pF}$, See Figure 17	25°C	2.5 V	5	8	13.5	ns
			Full	2.3 V to 2.7 V	3.5		14	
Turn-off time	t_{OFF}	$V_{COM} = 1.5 \text{ V}$, $R_L = 300 \Omega$, $C_L = 35 \text{ pF}$, See Figure 17	25°C	2.5 V	1	3.5	6.5	ns
			Full	2.3 V to 2.7 V	1		7.5	
Break-before-make time	t_{BBM}	$V_{NC} = V_{NO} = V_+/2$, $R_L = 50 \Omega$, $C_L = 35 \text{ pF}$, See Figure 18	25°C	2.5 V	3.5	5	7	ns
			Full	2.3 V to 2.7 V	3		7.5	
Charge injection	Q_C	$V_{GEN} = 0$, $R_{GEN} = 0$, $C_L = 0.1 \text{ nF}$, See Figure 22	25°C	2.5 V		2		pC
NO, NC OFF capacitance	$C_{NO(OFF)}$, $C_{NC(OFF)}$	V_{NO} or $V_{NC} = V_+$ or GND, Switch OFF, See Figure 16	25°C	2.5 V		5.5		pF
NO, NC ON capacitance	$C_{NO(ON)}$, $C_{NC(ON)}$	V_{NO} or $V_{NC} = V_+$ or GND, Switch ON, See Figure 16	25°C	2.5 V		17.5		pF
COM ON capacitance	$C_{COM(ON)}$	$V_{COM} = V_+$ or GND, Switch ON, See Figure 16	25°C	2.5 V		17.5		pF
Digital input capacitance	C_I	$V_I = V_+$ or GND, See Figure 16	25°C	2.5 V		2.8		pF
Bandwidth	BW	$R_L = 50 \Omega$, Switch ON, See Figure 19	25°C	2.5 V		300		MHz
OFF isolation	O_{ISO}	$R_L = 50 \Omega$, $f = 10 \text{ MHz}$, Switch OFF, See Figure 20	25°C	2.5 V		-65		dB
Crosstalk	X_{TALK}	$R_L = 50 \Omega$, $f = 10 \text{ MHz}$, Switch ON, See Figure 21	25°C	2.5 V		-66		dB
Total harmonic distortion	THD	$R_L = 600 \Omega$, $C_L = 50 \text{ pF}$, $f = 20 \text{ Hz to } 20 \text{ kHz}$, See Figure 23	25°C	2.5 V		0.025		%
Supply								
Positive supply current	I_+	$V_I = V_+$ or GND, Switch ON or OFF	25°C	2.7 V		2.5	5	μA
			Full				10	

(1) The algebraic convention, whereby the most negative value is a minimum and the most positive value is a maximum.

Electrical Characteristics for 1.8-V Supply⁽¹⁾

$V_+ = 1.65\text{ V to }1.95\text{ V}$, $T_A = -40^\circ\text{C to }85^\circ\text{C}$ (unless otherwise noted)

PARAMETER	SYMBOL	TEST CONDITIONS	T_A	V_+	MIN	TYP	MAX	UNIT
Analog Switch								
Analog signal range	V_{COM}, V_{NO}, V_{NC}				0		V_+	V
ON-state resistance	r_{on}	$0 \leq (V_{NO} \text{ or } V_{NC}) \leq V_+$, $I_{COM} = -4\text{ mA}$, Switch ON, See Figure 13	25°C Full	1.65 V		140 160	160	Ω
ON-state resistance match between channels	Δr_{on}	$V_{NO} \text{ or } V_{NC} = 1.16\text{ V}$, $I_{COM} = -4\text{ mA}$, Switch ON, See Figure 13	25°C Full	1.65 V		0.5 0.75	0.6	Ω
ON-state resistance flatness	$r_{on(Flat)}$	$0 \leq (V_{NO} \text{ or } V_{NC}) \leq V_+$, $I_{COM} = -4\text{ mA}$, Switch ON, See Figure 13	25°C Full	1.65 V		125 140	130	Ω
NO, NC OFF leakage current	$I_{NO(OFF)}, I_{NC(OFF)}$	$V_{NO} \text{ or } V_{NC} = 0.3\text{ V}$, $V_{COM} = 1.65\text{ V}$, or $V_{NO} \text{ or } V_{NC} = 1.65\text{ V}$, $V_{COM} = 0.3\text{ V}$, Switch OFF, See Figure 14	25°C Full	1.95 V	-0.1 -0.2	0.05 0.1	0.1 0.2	μA
NO, NC ON leakage current	$I_{NO(ON)}, I_{NC(ON)}$	$V_{NO} \text{ or } V_{NC} = 0.3\text{ V}$, $V_{COM} = \text{Open}$, or $V_{NO} \text{ or } V_{NC} = 1.65\text{ V}$, $V_{COM} = \text{Open}$, Switch ON, See Figure 15	25°C Full	1.95 V	-0.1 -0.2	0.05 0.1	0.1 0.2	μA
COM ON leakage current	$I_{COM(ON)}$	$V_{COM} = 0.3\text{ V}$, $V_{NO} \text{ or } V_{NC} = \text{Open}$, or $V_{COM} = 1.65\text{ V}$, $V_{NO} \text{ or } V_{NC} = \text{Open}$, Switch ON, See Figure 15	25°C Full	1.95 V	-0.1 -0.2	0.05 0.1	0.1 0.2	μA
Digital Control Input (IN)								
Input logic high	V_{IH}		Full		$V_+ \times 0.65$		5.5	V
Input logic low	V_{IL}		Full		0	$V_+ \times 0.35$		V
Input leakage current	I_{IH}, I_{IL}	$V_I = 5.5\text{ V or }0$	25°C Full	1.95 V	-0.1 -1	0.05	0.1 1	μA

(1) The algebraic convention, whereby the most negative value is a minimum and the most positive value is a maximum.

TS5A3157

10-Ω SPDT ANALOG SWITCH

SCDS219A–NOVEMBER 2005–REVISED OCTOBER 2007

Electrical Characteristics for 1.8-V Supply⁽¹⁾(Continued)

$V_+ = 1.65\text{ V to }1.95\text{ V}$, $T_A = -40^\circ\text{C to }85^\circ\text{C}$ (unless otherwise noted)

PARAMETER	SYMBOL	TEST CONDITIONS	T_A	V_+	MIN	TYP	MAX	UNIT	
Dynamic									
Turn-on time	t_{ON}	$V_{COM} = 1.3\text{ V}$, $R_L = 300\ \Omega$,	$C_L = 35\text{ pF}$, See Figure 17	25°C	1.8 V	5	15	23	ns
				Full	1.65 V to 1.95 V	7		24	
Turn-off time	t_{OFF}	$V_{COM} = 1.3\text{ V}$, $R_L = 300\ \Omega$,	$C_L = 35\text{ pF}$, See Figure 17	25°C	1.8 V	1	3.5	6.5	ns
				Full	1.65 V to 1.95 V	1		7.5	
Break-before-make time	t_{BBM}	$V_{NC} = V_{NO} = V_+/2$, $R_L = 50\ \Omega$,	$C_L = 35\text{ pF}$, See Figure 18	25°C	1.8 V	5.5	7.5	9	ns
				Full	1.65 V to 1.95 V	5.2		12	
Charge injection	Q_C	$V_{GEN} = 0$, $R_{GEN} = 0$,	$C_L = 0.1\text{ nF}$, See Figure 22	25°C	1.8 V		1	pC	
NO, NC OFF capacitance	$C_{NO(OFF)}$, $C_{NC(OFF)}$	V_{NO} or $V_{NC} = V_+$ or GND, Switch OFF,	See Figure 16	25°C	1.8 V		5.5	pF	
NO, NC ON capacitance	$C_{NO(ON)}$, $C_{NC(ON)}$	V_{NO} or $V_{NC} = V_+$ or GND, Switch ON,	See Figure 16	25°C	1.8 V		17.5	pF	
COM ON capacitance	$C_{COM(ON)}$	$V_{COM} = V_+$ or GND, Switch ON,	See Figure 16	25°C	1.8 V		17.5	pF	
Digital input capacitance	C_I	$V_I = V_+$ or GND,	See Figure 16	25°C	1.8 V		2.8	pF	
Bandwidth	BW	$R_L = 50\ \Omega$, Switch ON,	See Figure 19	25°C	1.8 V		300	MHz	
OFF isolation	O_{ISO}	$R_L = 50\ \Omega$, $f = 10\text{ MHz}$,	Switch OFF, See Figure 20	25°C	1.8 V		-65	dB	
Crosstalk	X_{TALK}	$R_L = 50\ \Omega$, $f = 10\text{ MHz}$,	Switch ON, See Figure 21	25°C	1.8 V		-66	dB	
Total harmonic distortion	THD	$R_L = 10\text{ k}\Omega$, $C_L = 50\text{ pF}$,	$f = 20\text{ Hz to }20\text{ kHz}$, See Figure 23	25°C	1.8 V		0.015	%	
Supply									
Positive supply current	I_+	$V_I = V_+$ or GND,	Switch ON or OFF	25°C	1.95 V		2.5	5	μA
				Full				10	

(1) The algebraic convention, whereby the most negative value is a minimum and the most positive value is a maximum.

TYPICAL PERFORMANCE

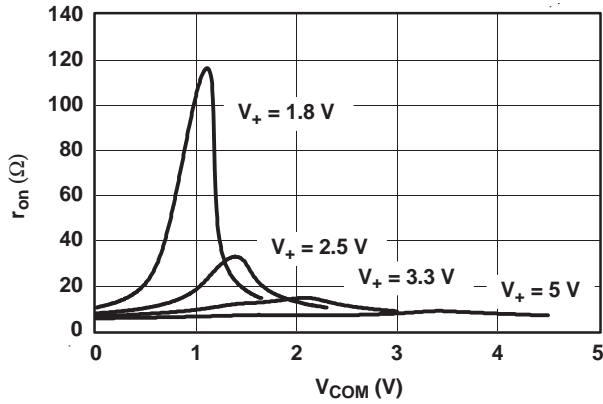

Figure 1. r_{on} vs V_{COM}

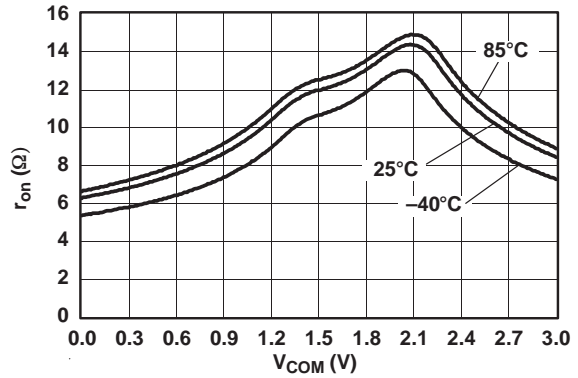

Figure 2. r_{on} vs V_{COM} ($V_+ = 3$ V)

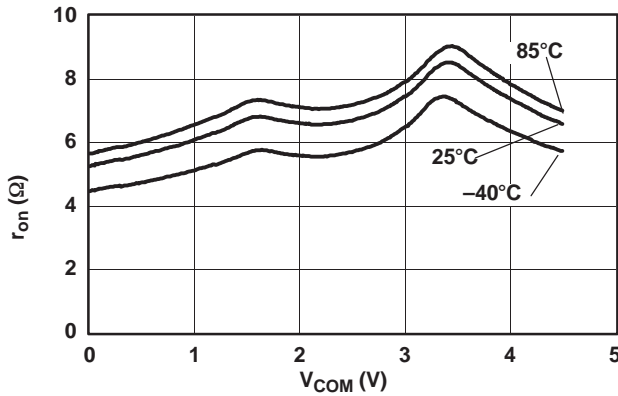

Figure 3. r_{on} vs V_{COM} ($V_+ = 4.5$ V)

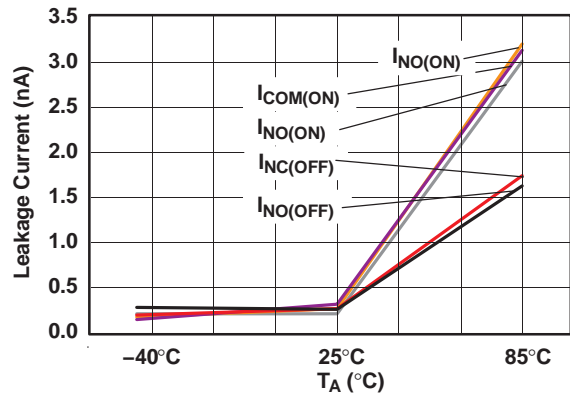

Figure 4. Leakage Current vs Temperature ($V_+ = 5.5$ V)

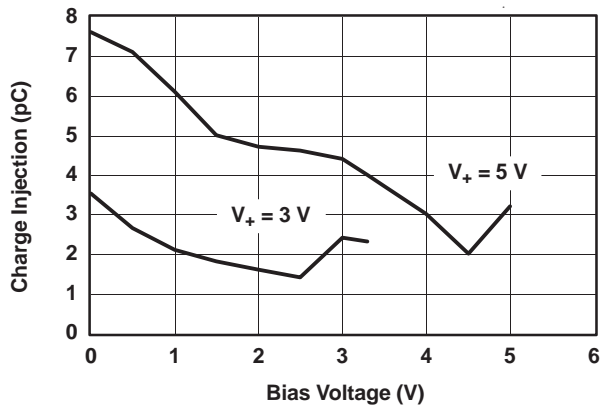

Figure 5. Charge Injection (Q_C) vs V_{COM}

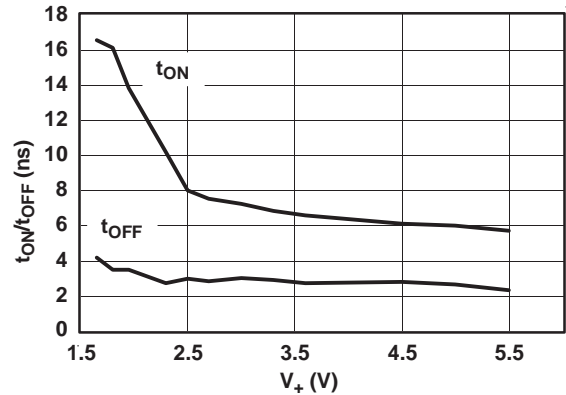

Figure 6. t_{ON} and t_{OFF} vs Supply Voltage

TYPICAL PERFORMANCE

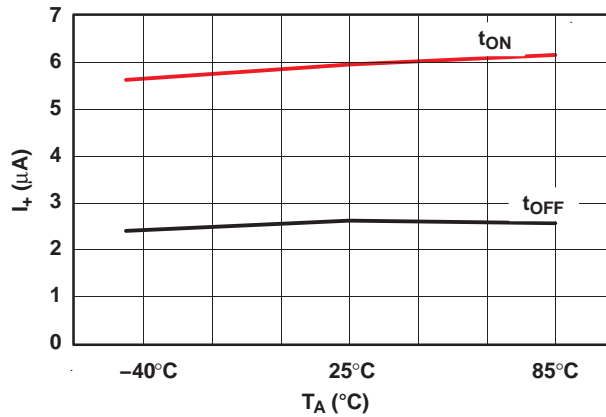

Figure 7. t_{ON} and t_{OFF} vs Temperature ($V_+ = 5\text{ V}$)

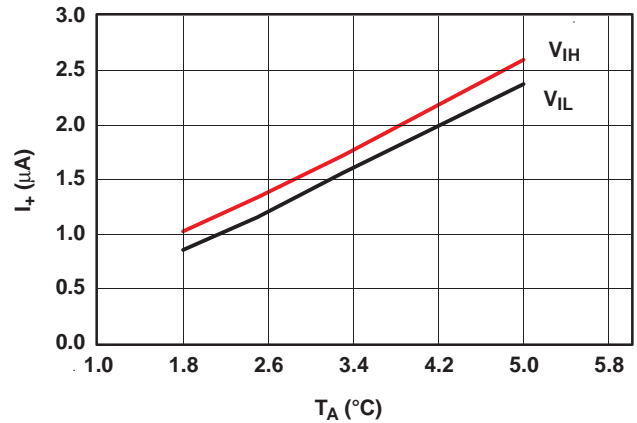

Figure 8. Logic-Level Threshold vs V_+

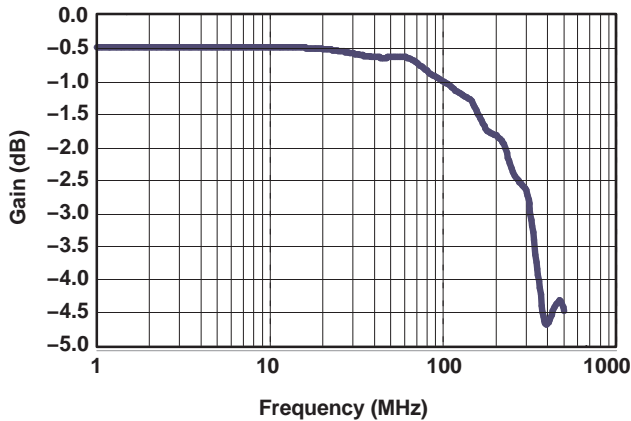

Figure 9. Bandwidth (Gain vs Frequency) ($V_+ = 5\text{ V}$)

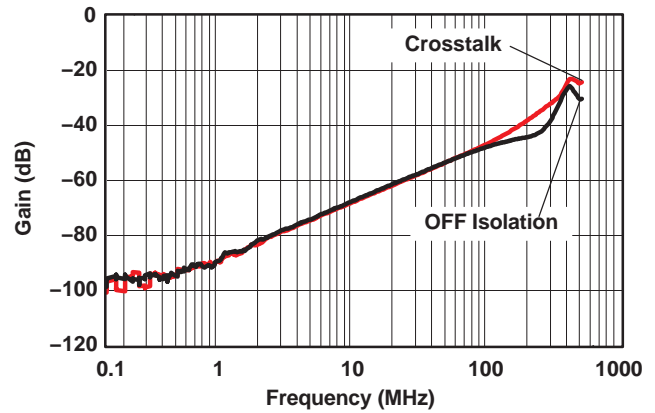

Figure 10. OFF Isolation ($V_+ = 5\text{ V}$)

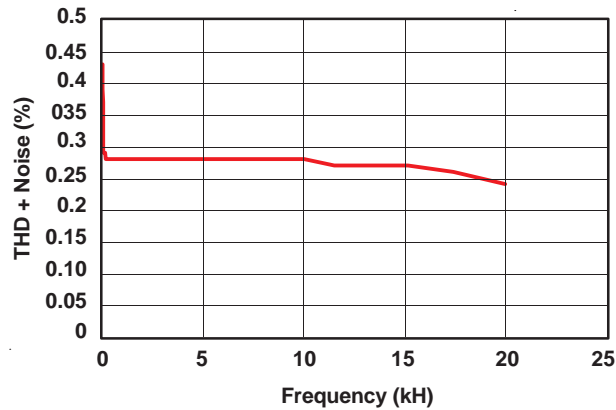

Figure 11. Total Harmonic Distortion vs Frequency

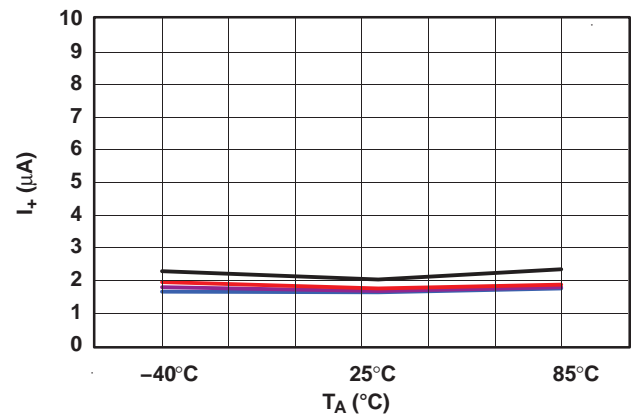

Figure 12. Power-Supply Current vs Temperature ($V_+ = 5\text{ V}$)

PIN DESCRIPTION

PIN NO.	NAME	DESCRIPTION
1	NO	Normally open
2	GND	Digital ground
3	NC	Normally closed
4	COM	Common
5	V ₊	Power supply
6	IN	Digital control to connect the COM to NO or NC

PARAMETER DESCRIPTION

SYMBOL	DESCRIPTION
V _{COM}	Voltage at COM
V _{NC}	Voltage at NC
V _{NO}	Voltage at NO
r _{on}	Resistance between COM and NC or COM and NO ports when the channel is ON
Δr _{on}	Difference of r _{on} between channels in a specific device
r _{on(flat)}	Difference between the maximum and minimum value of r _{on} in a channel over the specified range of conditions
I _{NC(OFF)}	Leakage current measured at the NC port, with the corresponding channel (NC to COM) in the OFF state
I _{NO(OFF)}	Leakage current measured at the NO port, with the corresponding channel (NO to COM) in the OFF state
I _{NC(ON)}	Leakage current measured at the NC port, with the corresponding channel (NC to COM) in the ON state and the output (COM) open
I _{NO(ON)}	Leakage current measured at the NO port, with the corresponding channel (NO to COM) in the ON state and the output (COM) open
I _{COM(ON)}	Leakage current measured at the COM port, with the corresponding channel (COM to NO or COM to NC) in the ON state and the output (NC or NO) open
V _{IH}	Minimum input voltage for logic high for the control input (IN)
V _{IL}	Maximum input voltage for logic low for the control input (IN)
V _I	Voltage at the control input (IN)
I _{IH} , I _{IL}	Leakage current measured at the control input (IN)
t _{ON}	Turn-on time for the switch. This parameter is measured under the specified range of conditions and by the propagation delay between the digital control (IN) signal and analog output (COM, NC, or NO) signal when the switch is turning ON.
t _{OFF}	Turn-off time for the switch. This parameter is measured under the specified range of conditions and by the propagation delay between the digital control (IN) signal and analog output (COM, NC, or NO) signal when the switch is turning OFF.
t _{BBM}	Break-before-make time. This parameter is measured under the specified range of conditions and by the propagation delay between the output of two adjacent analog channels (NC and NO) when the control signal changes state.
Q _C	Charge injection is a measurement of unwanted signal coupling from the control (IN) input to the analog (NC, NO, or COM) output. This is measured in coulomb (C) and measured by the total charge induced due to switching of the control input. Charge injection, Q _C = C _L × ΔV _{COM} , C _L is the load capacitance and ΔV _{COM} is the change in analog output voltage.
C _{NC(OFF)}	Capacitance at the NC port when the corresponding channel (NC to COM) is OFF
C _{NO(OFF)}	Capacitance at the NO port when the corresponding channel (NO to COM) is OFF
C _{NC(ON)}	Capacitance at the NC port when the corresponding channel (NC to COM) is ON
C _{NO(ON)}	Capacitance at the NO port when the corresponding channel (NO to COM) is ON
C _{COM(ON)}	Capacitance at the COM port when the corresponding channel (COM to NC or COM to NO) is ON
C _I	Capacitance of control input (IN)
O _{ISO}	OFF isolation of the switch is a measurement of OFF-state switch impedance. This is measured in dB in a specific frequency, with the corresponding channel (NC to COM or NO to COM) in the OFF state.
X _{TALK}	Crosstalk is a measurement of unwanted signal coupling from an ON channel to an OFF channel (NC to NO or NO to NC). This is measured in a specific frequency and in dB.
BW	Bandwidth of the switch. This is the frequency where the gain of an ON channel is –3 dB below the DC gain.
THD	Total harmonic distortion describes the signal distortion caused by the analog switch. This is defined as the ratio of root mean square (RMS) value of the second, third, and higher harmonic to the absolute magnitude of fundamental harmonic.
I ₊	Static power-supply current with the control (IN) pin at V ₊ or GND

PARAMETER MEASUREMENT INFORMATION

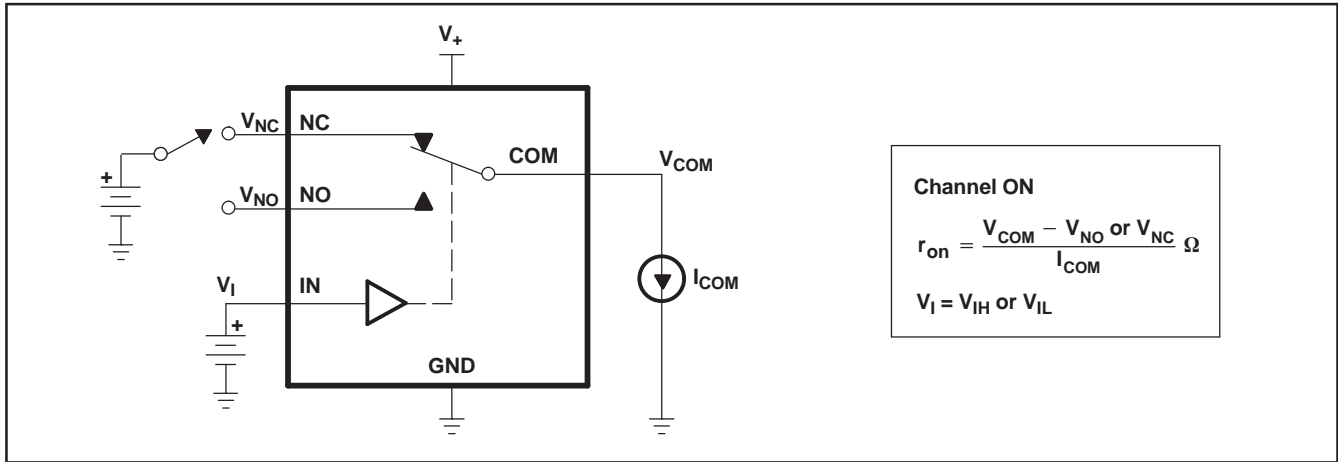

Figure 13. ON-State Resistance (r_{on})

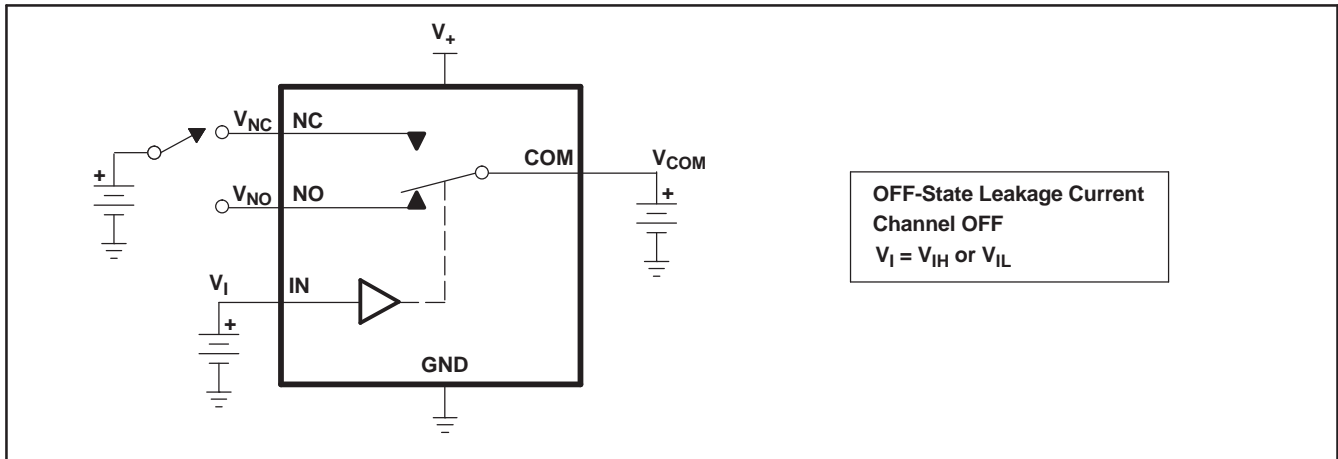

Figure 14. OFF-State Leakage Current ($I_{NC(OFF)}$, $I_{NO(OFF)}$)

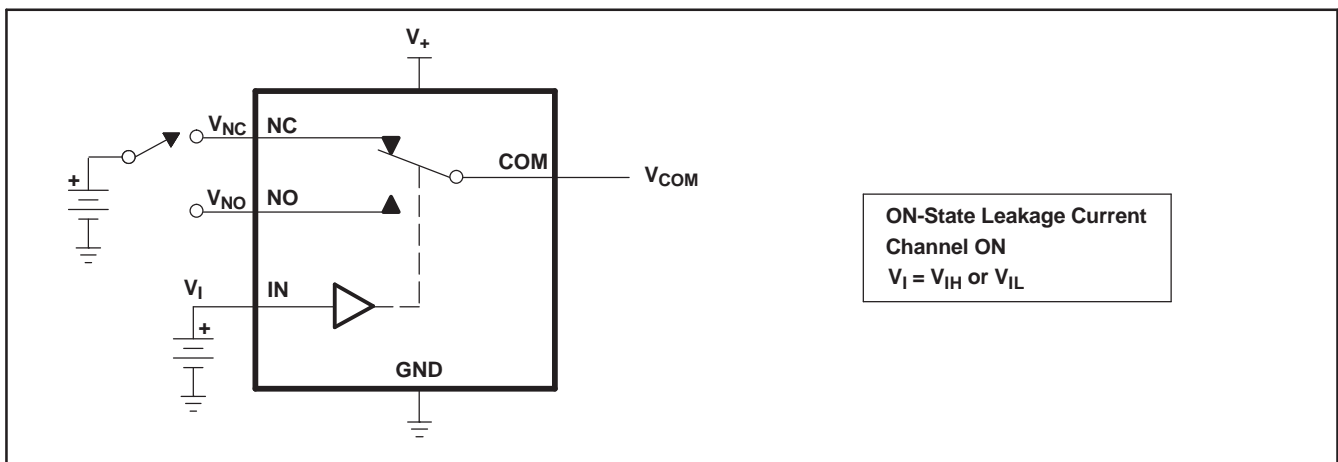

Figure 15. ON-State Leakage Current ($I_{COM(ON)}$, $I_{NC(ON)}$, $I_{NO(ON)}$)

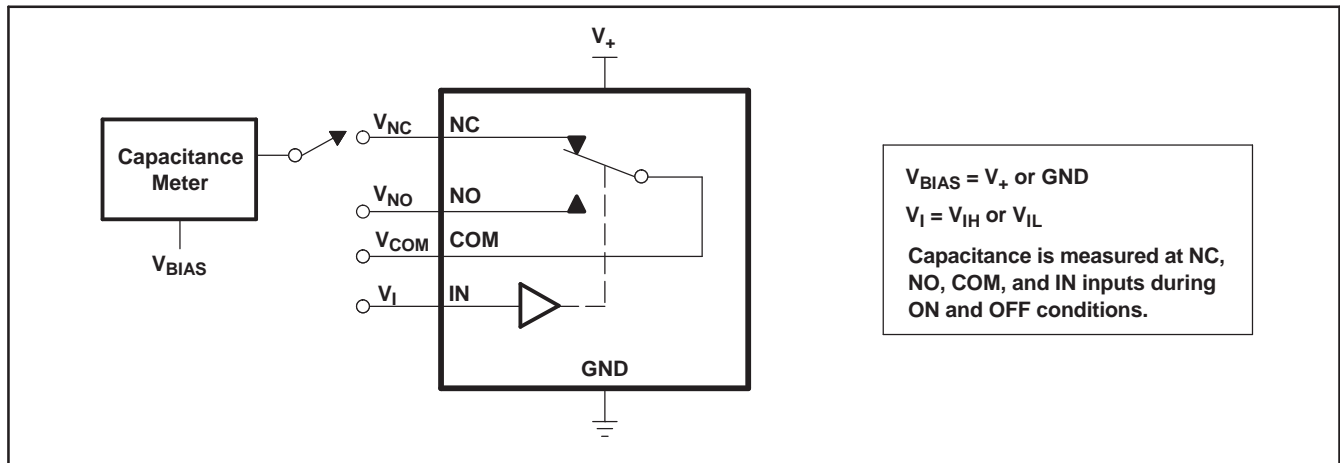
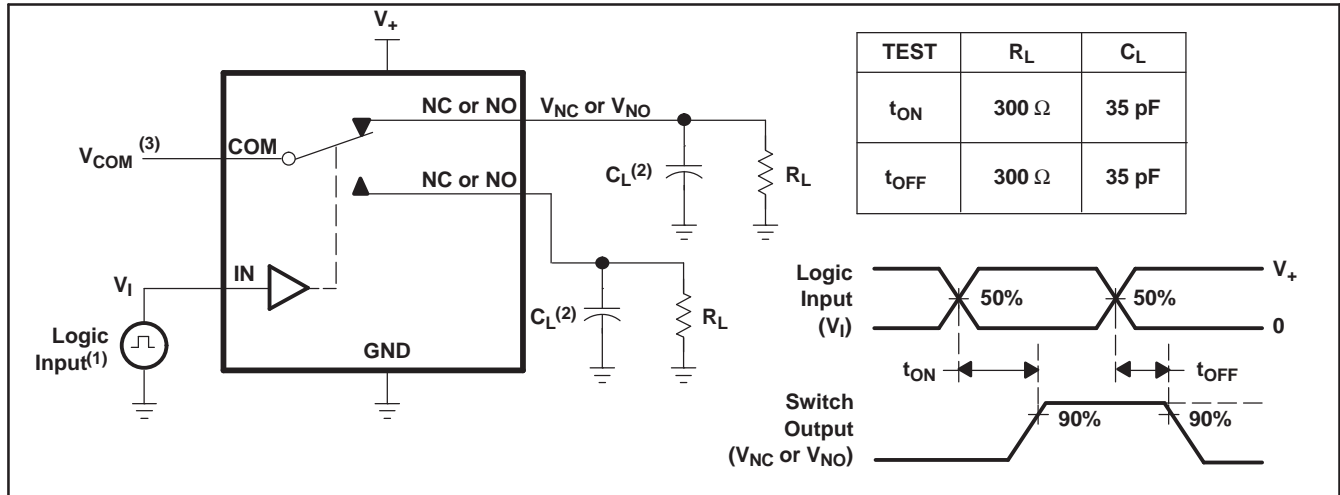
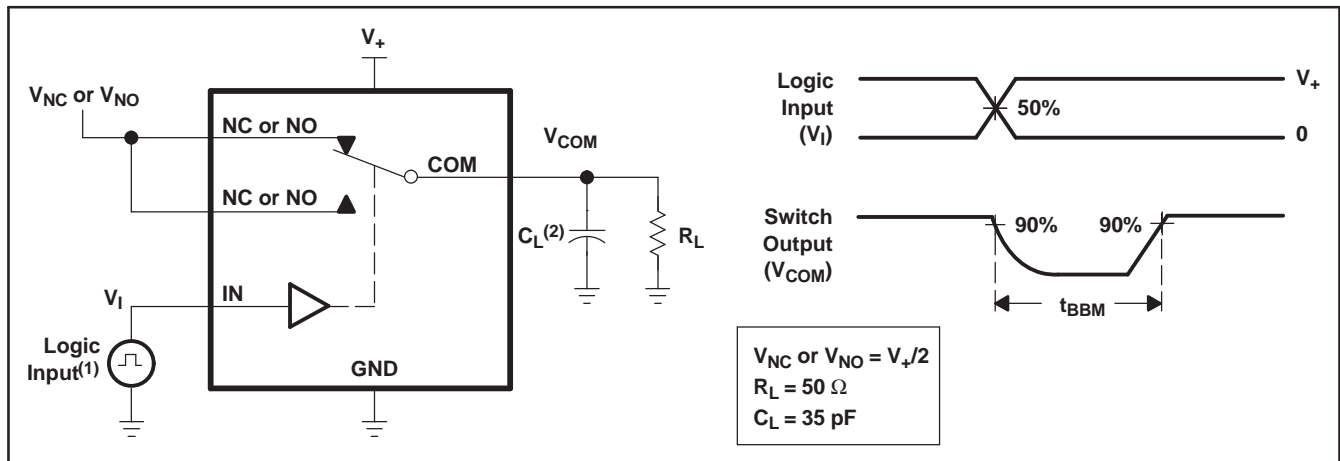

Figure 16. Capacitance (C_I , $C_{COM(ON)}$, $C_{NC(OFF)}$, $C_{NO(OFF)}$, $C_{NC(ON)}$, $C_{NO(ON)}$)



- (1) All input pulses are supplied by generators having the following characteristics: PRR \leq 10 MHz, $Z_O = 50 \Omega$, $t_r < 5$ ns, $t_f < 5$ ns.
- (2) C_L includes probe and jig capacitance.
- (3) See Electrical Characteristic for V_{COM} .

Figure 17. Turn-On (t_{ON}) and Turn-Off Time (t_{OFF})



(1) All input pulses are supplied by generators having the following characteristics: $PRR \leq 10 \text{ MHz}$, $Z_O = 50 \Omega$, $t_r < 5 \text{ ns}$, $t_f < 5 \text{ ns}$.

(2) C_L includes probe and jig capacitance.

Figure 18. Break-Before-Make Time (t_{BBM})

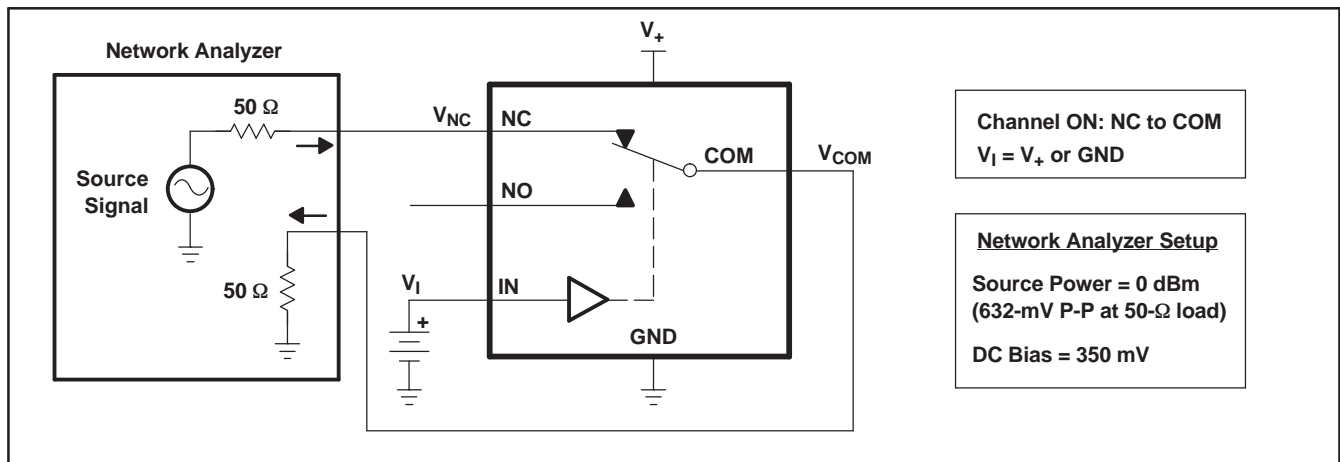

Figure 19. Bandwidth (BW)

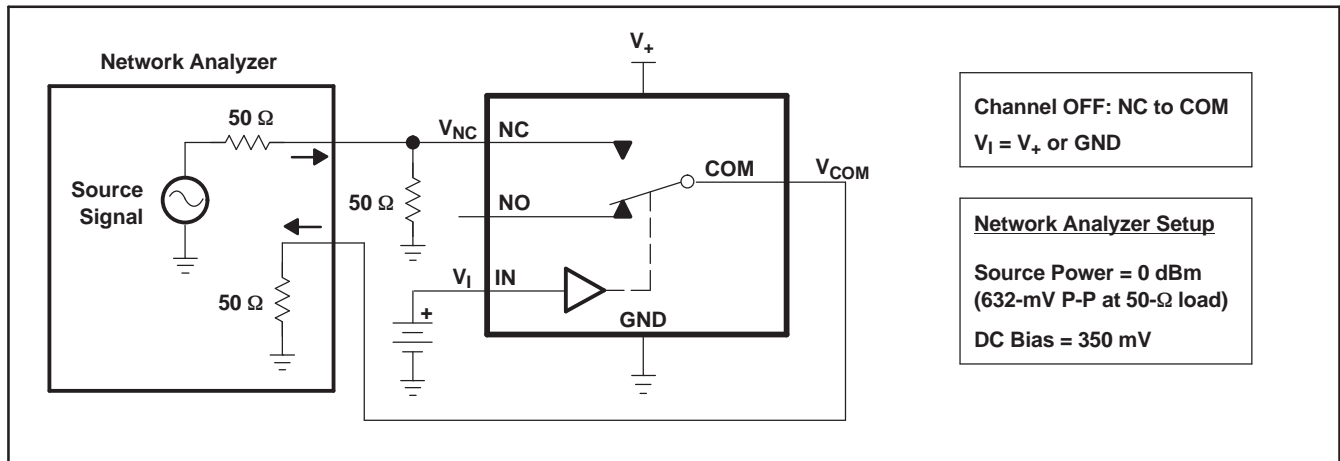

Figure 20. OFF Isolation (O_{ISO})

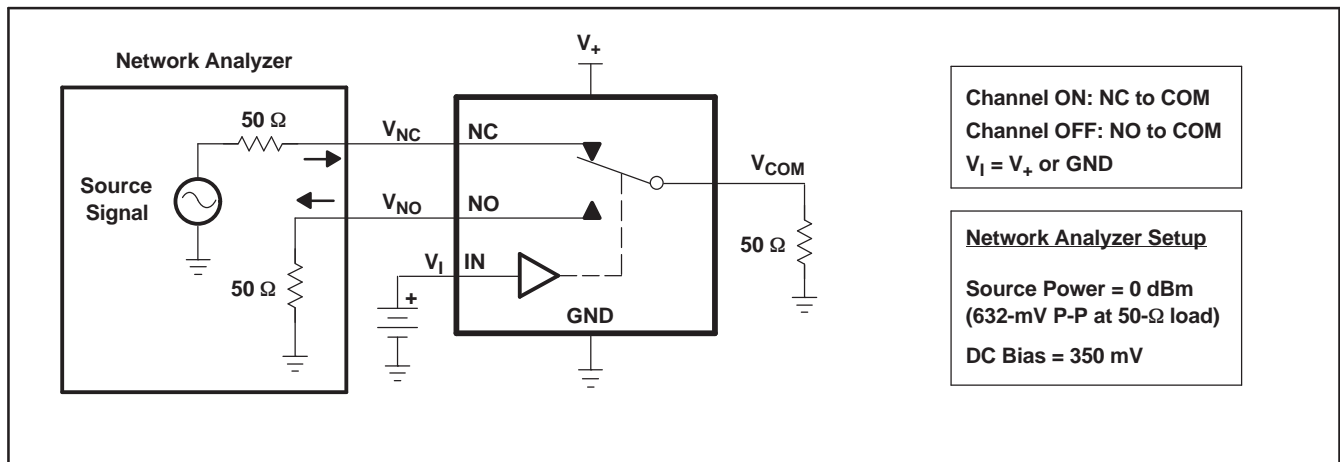
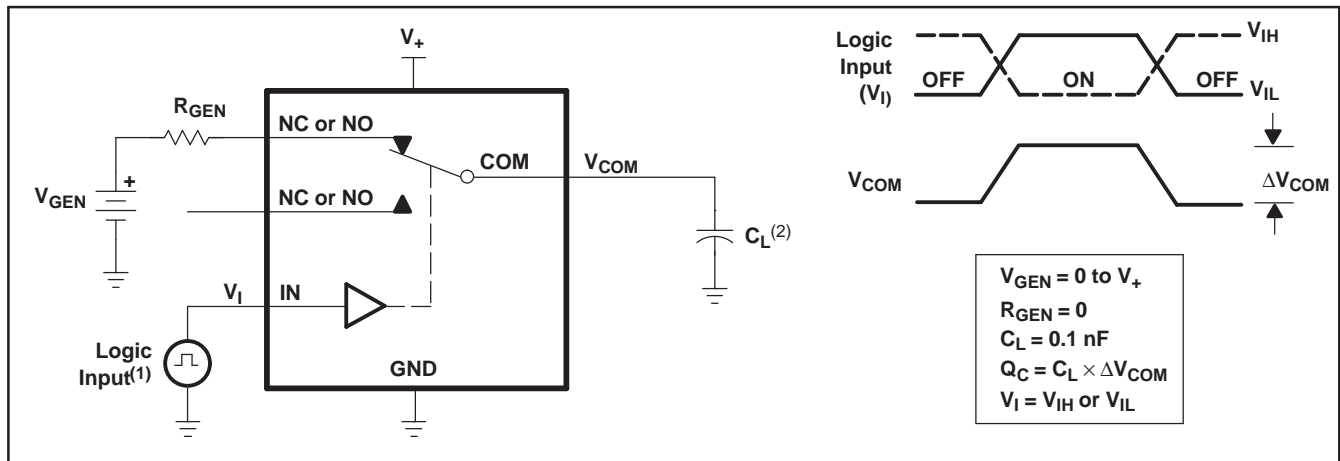
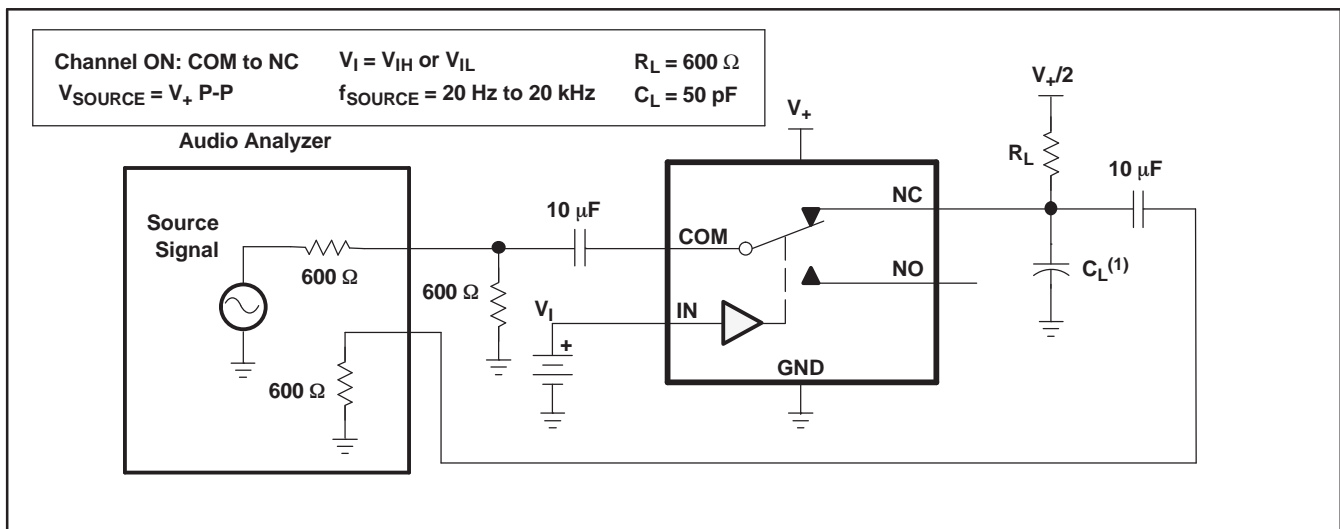

Figure 21. Crosstalk (X_{TALK})



- (1) All input pulses are supplied by generators having the following characteristics: PRR ≤ 10 MHz, $Z_O = 50 \Omega$, $t_r < 5 \text{ ns}$, $t_f < 5 \text{ ns}$.
(2) C_L includes probe and jig capacitance.

Figure 22. Charge Injection (Q_C)



- (1) C_L includes probe and jig capacitance.

Figure 23. Total Harmonic Distortion (THD)

PACKAGING INFORMATION

Orderable Device	Status (1)	Package Type	Package Drawing	Pins	Package Qty	Eco Plan (2)	Lead/Ball Finish	MSL Peak Temp (3)	Op Temp (°C)	Top-Side Markings (4)	Samples
TS5A3157DBVR	ACTIVE	SOT-23	DBV	6	3000	Green (RoHS & no Sb/Br)	CU NIPDAU	Level-1-260C-UNLIM	-40 to 85	JC5R	Samples
TS5A3157DBVRE4	ACTIVE	SOT-23	DBV	6	3000	Green (RoHS & no Sb/Br)	CU NIPDAU	Level-1-260C-UNLIM	-40 to 85	JC5R	Samples
TS5A3157DBVRG4	ACTIVE	SOT-23	DBV	6	3000	Green (RoHS & no Sb/Br)	CU NIPDAU	Level-1-260C-UNLIM	-40 to 85	JC5R	Samples
TS5A3157DCKR	ACTIVE	SC70	DCK	6	3000	Green (RoHS & no Sb/Br)	CU NIPDAU	Level-1-260C-UNLIM	-40 to 85	(JC5 ~ JCF ~ JCR)	Samples
TS5A3157DCKRE4	ACTIVE	SC70	DCK	6	3000	Green (RoHS & no Sb/Br)	CU NIPDAU	Level-1-260C-UNLIM	-40 to 85	(JC5 ~ JCF ~ JCR)	Samples
TS5A3157DCKRG4	ACTIVE	SC70	DCK	6	3000	Green (RoHS & no Sb/Br)	CU NIPDAU	Level-1-260C-UNLIM	-40 to 85	(JC5 ~ JCF ~ JCR)	Samples
TS5A3157YZPR	ACTIVE	DSBGA	YZP	6	3000	Green (RoHS & no Sb/Br)	SNAGCU	Level-1-260C-UNLIM	-40 to 85	(JC7 ~ JCN)	Samples

(1) The marketing status values are defined as follows:

ACTIVE: Product device recommended for new designs.

LIFEBUY: TI has announced that the device will be discontinued, and a lifetime-buy period is in effect.

NRND: Not recommended for new designs. Device is in production to support existing customers, but TI does not recommend using this part in a new design.

PREVIEW: Device has been announced but is not in production. Samples may or may not be available.

OBSOLETE: TI has discontinued the production of the device.

(2) Eco Plan - The planned eco-friendly classification: Pb-Free (RoHS), Pb-Free (RoHS Exempt), or Green (RoHS & no Sb/Br) - please check <http://www.ti.com/productcontent> for the latest availability information and additional product content details.

TBD: The Pb-Free/Green conversion plan has not been defined.

Pb-Free (RoHS): TI's terms "Lead-Free" or "Pb-Free" mean semiconductor products that are compatible with the current RoHS requirements for all 6 substances, including the requirement that lead not exceed 0.1% by weight in homogeneous materials. Where designed to be soldered at high temperatures, TI Pb-Free products are suitable for use in specified lead-free processes.

Pb-Free (RoHS Exempt): This component has a RoHS exemption for either 1) lead-based flip-chip solder bumps used between the die and package, or 2) lead-based die adhesive used between the die and leadframe. The component is otherwise considered Pb-Free (RoHS compatible) as defined above.

Green (RoHS & no Sb/Br): TI defines "Green" to mean Pb-Free (RoHS compatible), and free of Bromine (Br) and Antimony (Sb) based flame retardants (Br or Sb do not exceed 0.1% by weight in homogeneous material)

(3) MSL, Peak Temp. -- The Moisture Sensitivity Level rating according to the JEDEC industry standard classifications, and peak solder temperature.

(4) Multiple Top-Side Markings will be inside parentheses. Only one Top-Side Marking contained in parentheses and separated by a "~" will appear on a device. If a line is indented then it is a continuation of the previous line and the two combined represent the entire Top-Side Marking for that device.

Important Information and Disclaimer: The information provided on this page represents TI's knowledge and belief as of the date that it is provided. TI bases its knowledge and belief on information provided by third parties, and makes no representation or warranty as to the accuracy of such information. Efforts are underway to better integrate information from third parties. TI has taken and continues to take reasonable steps to provide representative and accurate information but may not have conducted destructive testing or chemical analysis on incoming materials and chemicals. TI and TI suppliers consider certain information to be proprietary, and thus CAS numbers and other limited information may not be available for release.

In no event shall TI's liability arising out of such information exceed the total purchase price of the TI part(s) at issue in this document sold by TI to Customer on an annual basis.

TAPE AND REEL INFORMATION

QUADRANT ASSIGNMENTS FOR PIN 1 ORIENTATION IN TAPE

*All dimensions are nominal

Device	Package Type	Package Drawing	Pins	SPQ	Reel Diameter (mm)	Reel Width W1 (mm)	A0 (mm)	B0 (mm)	K0 (mm)	P1 (mm)	W (mm)	Pin1 Quadrant
TS5A3157DBVR	SOT-23	DBV	6	3000	180.0	8.4	3.23	3.17	1.37	4.0	8.0	Q3
TS5A3157DCKR	SC70	DCK	6	3000	178.0	9.2	2.4	2.4	1.22	4.0	8.0	Q3
TS5A3157DCKR	SC70	DCK	6	3000	178.0	9.0	2.4	2.5	1.2	4.0	8.0	Q3
TS5A3157YZPR	DSBGA	YZP	6	3000	178.0	9.2	1.02	1.52	0.63	4.0	8.0	Q1

TAPE AND REEL BOX DIMENSIONS



*All dimensions are nominal

Device	Package Type	Package Drawing	Pins	SPQ	Length (mm)	Width (mm)	Height (mm)
TS5A3157DBVR	SOT-23	DBV	6	3000	202.0	201.0	28.0
TS5A3157DCKR	SC70	DCK	6	3000	338.0	343.0	30.0
TS5A3157DCKR	SC70	DCK	6	3000	180.0	180.0	18.0
TS5A3157YZPR	DSBGA	YZP	6	3000	220.0	220.0	35.0

MECHANICAL DATA

DBV (R-PDSO-G6)

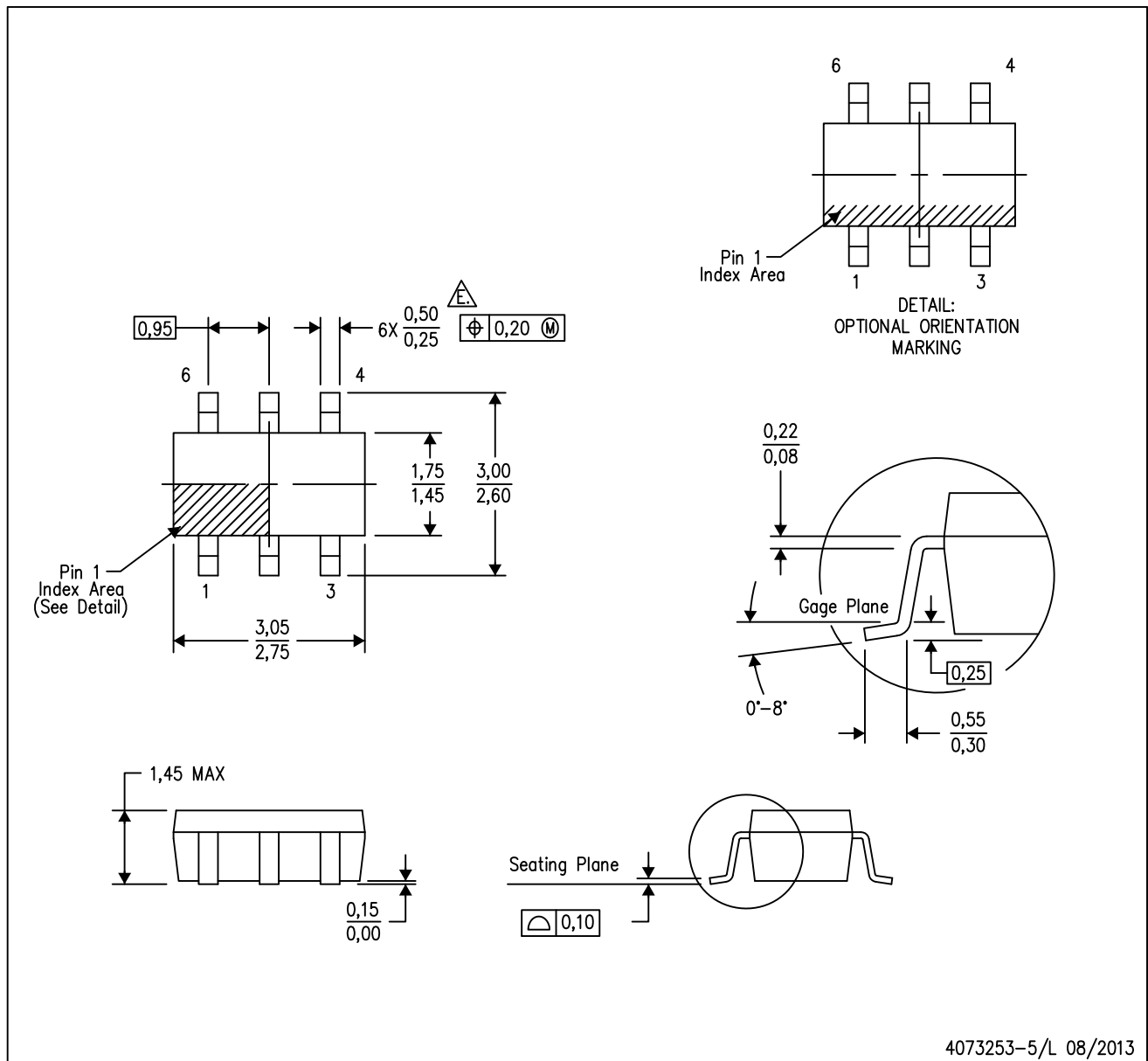
PLASTIC SMALL-OUTLINE PACKAGE



- NOTES:
- A. All linear dimensions are in millimeters.
 - B. This drawing is subject to change without notice.
 - C. Body dimensions do not include mold flash or protrusion. Mold flash and protrusion shall not exceed 0.15 per side.
 - D. Leads 1,2,3 may be wider than leads 4,5,6 for package orientation.
-  Falls within JEDEC MO-178 Variation AB, except minimum lead width.

DBV (R-PDSO-G6)

PLASTIC SMALL OUTLINE



- NOTES:
- A. All linear dimensions are in millimeters.
 - B. This drawing is subject to change without notice.
 - C. Customers should place a note on the circuit board fabrication drawing not to alter the center solder mask defined pad.
 - D. Publication IPC-7351 is recommended for alternate designs.
 - E. Laser cutting apertures with trapezoidal walls and also rounding corners will offer better paste release. Customers should contact their board assembly site for stencil design recommendations. Example stencil design based on a 50% volumetric metal load solder paste. Refer to IPC-7525 for other stencil recommendations.

DCK (R-PDSO-G6)

PLASTIC SMALL-OUTLINE PACKAGE



- NOTES:
- A. All linear dimensions are in millimeters.
 - B. This drawing is subject to change without notice.
 - C. Body dimensions do not include mold flash or protrusion. Mold flash and protrusion shall not exceed 0.15 per side.
 - D. Falls within JEDEC MO-203 variation AB.

DCK (R-PDSO-G6)

PLASTIC SMALL OUTLINE



- NOTES:
- All linear dimensions are in millimeters.
 - This drawing is subject to change without notice.
 - Customers should place a note on the circuit board fabrication drawing not to alter the center solder mask defined pad.
 - Publication IPC-7351 is recommended for alternate designs.
 - Laser cutting apertures with trapezoidal walls and also rounding corners will offer better paste release. Customers should contact their board assembly site for stencil design recommendations. Example stencil design based on a 50% volumetric metal load solder paste. Refer to IPC-7525 for other stencil recommendations.

YZP (R-XBGA-N6)

DIE-SIZE BALL GRID ARRAY

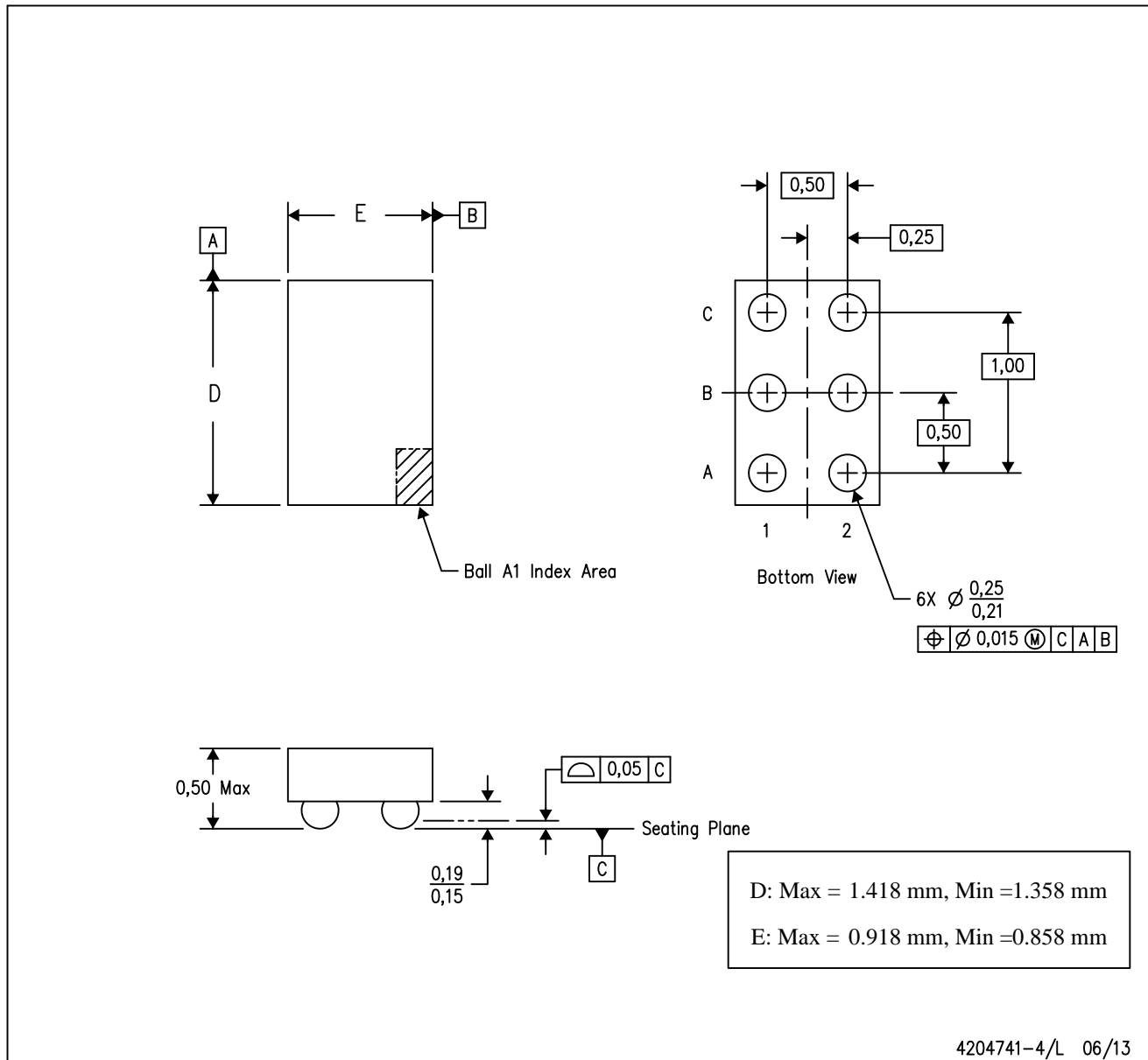

- NOTES:
- A. All linear dimensions are in millimeters. Dimensioning and tolerancing per ASME Y14.5M-1994.
 - B. This drawing is subject to change without notice.
 - C. NanoFree™ package configuration.

NanoFree is a trademark of Texas Instruments.

IMPORTANT NOTICE

Texas Instruments Incorporated and its subsidiaries (TI) reserve the right to make corrections, enhancements, improvements and other changes to its semiconductor products and services per JESD46, latest issue, and to discontinue any product or service per JESD48, latest issue. Buyers should obtain the latest relevant information before placing orders and should verify that such information is current and complete. All semiconductor products (also referred to herein as "components") are sold subject to TI's terms and conditions of sale supplied at the time of order acknowledgment.

TI warrants performance of its components to the specifications applicable at the time of sale, in accordance with the warranty in TI's terms and conditions of sale of semiconductor products. Testing and other quality control techniques are used to the extent TI deems necessary to support this warranty. Except where mandated by applicable law, testing of all parameters of each component is not necessarily performed.

TI assumes no liability for applications assistance or the design of Buyers' products. Buyers are responsible for their products and applications using TI components. To minimize the risks associated with Buyers' products and applications, Buyers should provide adequate design and operating safeguards.

TI does not warrant or represent that any license, either express or implied, is granted under any patent right, copyright, mask work right, or other intellectual property right relating to any combination, machine, or process in which TI components or services are used. Information published by TI regarding third-party products or services does not constitute a license to use such products or services or a warranty or endorsement thereof. Use of such information may require a license from a third party under the patents or other intellectual property of the third party, or a license from TI under the patents or other intellectual property of TI.

Reproduction of significant portions of TI information in TI data books or data sheets is permissible only if reproduction is without alteration and is accompanied by all associated warranties, conditions, limitations, and notices. TI is not responsible or liable for such altered documentation. Information of third parties may be subject to additional restrictions.

Resale of TI components or services with statements different from or beyond the parameters stated by TI for that component or service voids all express and any implied warranties for the associated TI component or service and is an unfair and deceptive business practice. TI is not responsible or liable for any such statements.

Buyer acknowledges and agrees that it is solely responsible for compliance with all legal, regulatory and safety-related requirements concerning its products, and any use of TI components in its applications, notwithstanding any applications-related information or support that may be provided by TI. Buyer represents and agrees that it has all the necessary expertise to create and implement safeguards which anticipate dangerous consequences of failures, monitor failures and their consequences, lessen the likelihood of failures that might cause harm and take appropriate remedial actions. Buyer will fully indemnify TI and its representatives against any damages arising out of the use of any TI components in safety-critical applications.

In some cases, TI components may be promoted specifically to facilitate safety-related applications. With such components, TI's goal is to help enable customers to design and create their own end-product solutions that meet applicable functional safety standards and requirements. Nonetheless, such components are subject to these terms.

No TI components are authorized for use in FDA Class III (or similar life-critical medical equipment) unless authorized officers of the parties have executed a special agreement specifically governing such use.

Only those TI components which TI has specifically designated as military grade or "enhanced plastic" are designed and intended for use in military/aerospace applications or environments. Buyer acknowledges and agrees that any military or aerospace use of TI components which have **not** been so designated is solely at the Buyer's risk, and that Buyer is solely responsible for compliance with all legal and regulatory requirements in connection with such use.

TI has specifically designated certain components as meeting ISO/TS16949 requirements, mainly for automotive use. In any case of use of non-designated products, TI will not be responsible for any failure to meet ISO/TS16949.

Products

Audio	www.ti.com/audio
Amplifiers	amplifier.ti.com
Data Converters	dataconverter.ti.com
DLP® Products	www.dlp.com
DSP	dsp.ti.com
Clocks and Timers	www.ti.com/clocks
Interface	interface.ti.com
Logic	logic.ti.com
Power Mgmt	power.ti.com
Microcontrollers	microcontroller.ti.com
RFID	www.ti-rfid.com
OMAP Applications Processors	www.ti.com/omap
Wireless Connectivity	www.ti.com/wirelessconnectivity

Applications

Automotive and Transportation	www.ti.com/automotive
Communications and Telecom	www.ti.com/communications
Computers and Peripherals	www.ti.com/computers
Consumer Electronics	www.ti.com/consumer-apps
Energy and Lighting	www.ti.com/energy
Industrial	www.ti.com/industrial
Medical	www.ti.com/medical
Security	www.ti.com/security
Space, Avionics and Defense	www.ti.com/space-avionics-defense
Video and Imaging	www.ti.com/video

TI E2E Community

e2e.ti.com

Mouser Electronics

Authorized Distributor

Click to View Pricing, Inventory, Delivery & Lifecycle Information:

Texas Instruments:

[TS5A3157DBVRG4](#) [TS5A3157DCKRG4](#) [TS5A3157DBVR](#) [TS5A3157DBVRE4](#) [TS5A3157DCKR](#)
[TS5A3157DCKRE4](#) [TS5A3157YZPR](#)