

TS5A23166 0.9-Ω Dual-SPST Analog Switch 5-V and 3.3-V 2-Channel Analog Switch

1 Features

- Isolation in Powered-Down Mode, $V_+ = 0$
- Low ON-State Resistance (0.9 Ω)
- Control Inputs are 5.5-V Tolerant
- Low Charge Injection
- Excellent ON-State Resistance Matching
- Low Total Harmonic Distortion (THD)
- 1.65-V to 5.5-V Single-Supply Operation
- Latch-Up Performance Exceeds 100 mA Per JESD 78, Class II
- ESD Performance Tested Per JESD 22
 - 2000-V Human-Body Model (A114-B, Class II)
 - 1000-V Charged-Device Model (C101)

2 Applications

- Cell Phones
- Portable Instrumentation
- Audio and Video Signal Routing
- Low-Voltage Data-Acquisition Systems
- Communication Circuits
- Modems
- Hard Drives
- Computer Peripherals
- Wireless Terminals and Peripherals

3 Description

The TS5A23166 device is a dual single-pole single-throw (SPST) analog switch that is designed to operate from 1.65 V to 5.5 V. The TS5A23166 device offers a low ON-state resistance and an excellent channel-to-channel ON-state resistance matching. The TS5A23166 device has excellent total harmonic distortion (THD) performance and consumes very low power. These features make this device suitable for portable audio applications.

Device Information⁽¹⁾

PART NUMBER	PACKAGE	BODY SIZE (NOM)
TS5A23166	VSSOP (8)	2.30 mm × 2.00 mm
	DSBGA (8)	1.91 mm × 0.91 mm

(1) For all available packages, see the orderable addendum at the end of the data sheet.

Simplified Schematic

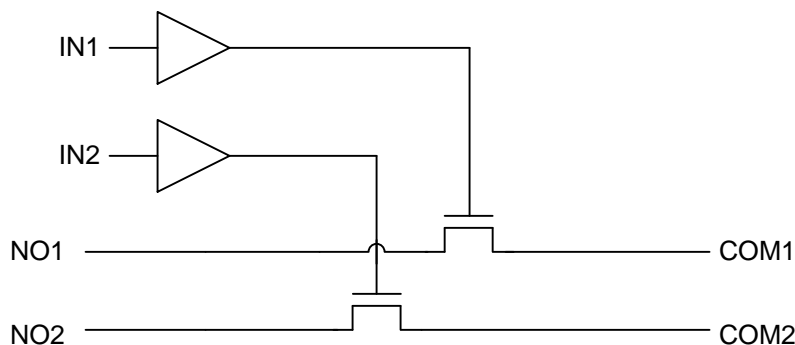

Table of Contents

1	Features	1	8	Detailed Description	18
2	Applications	1	8.1	Overview	18
3	Description	1	8.2	Functional Block Diagram	18
4	Revision History	2	8.3	Feature Description	18
5	Pin Configuration and Functions	3	8.4	Device Functional Modes	18
6	Specifications	3	9	Application and Implementation	19
6.1	Absolute Maximum Ratings	3	9.1	Application Information	19
6.2	ESD Ratings	4	9.2	Typical Application	19
6.3	Recommended Operating Conditions	4	10	Power Supply Recommendations	20
6.4	Thermal Information	4	11	Layout	20
6.5	Electrical Characteristics: 5-V Supply	4	11.1	Layout Guidelines	20
6.6	Electrical Characteristics: 3.3-V Supply	6	11.2	Layout Example	20
6.7	Electrical Characteristics: 2.5-V Supply	7	12	Device and Documentation Support	21
6.8	Electrical Characteristics: 1.8-V Supply	9	12.1	Device Support	21
6.9	Switching Characteristics: 5-V Supply	10	12.2	Community Resources	22
6.10	Switching Characteristics: 3.3-V Supply	10	12.3	Trademarks	22
6.11	Switching Characteristics: 2.5-V Supply	11	12.4	Electrostatic Discharge Caution	22
6.12	Switching Characteristics: 1.8-V Supply	11	12.5	Glossary	22
6.13	Typical Characteristics	12	13	Mechanical, Packaging, and Orderable Information	22
7	Parameter Measurement Information	14			

4 Revision History

NOTE: Page numbers for previous revisions may differ from page numbers in the current version.

Changes from Revision G (February 2013) to Revision H	Page
• Added <i>Pin Configuration and Functions</i> section, <i>ESD Ratings</i> table, <i>Feature Description</i> section, <i>Device Functional Modes</i> , <i>Application and Implementation</i> section, <i>Power Supply Recommendations</i> section, <i>Layout</i> section, <i>Device and Documentation Support</i> section, and <i>Mechanical, Packaging, and Orderable Information</i> section	1
• Updated document to new TI data sheet format - no specification changes.	1
• Removed <i>Ordering Information</i> table.	1

Changes from Revision F (September 2012) to Revision G	Page
• Changed pin numbers for YZT or YZP package pinout.	3

5 Pin Configuration and Functions

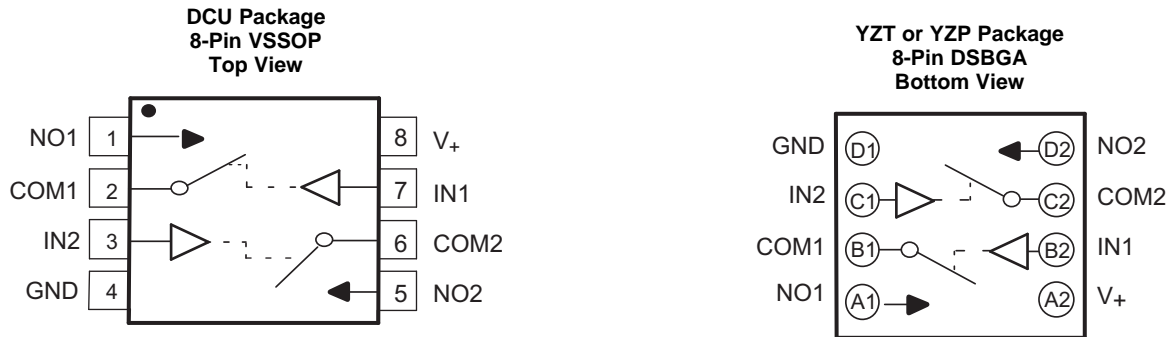

Pin Functions

PIN			TYPE	DESCRIPTION
NAME	TSSOP NO.	DSBGA NO.		
COM1	2	B1	I/O	Common port for switch 1
COM2	6	C2	I/O	Common port for switch 2
GND	4	D1	GND	Ground
IN1	7	B2	I	Active-high control pin connecting NO1 to COM1.
IN2	3	C1	I	Active-high control pin connecting NO2 to COM2.
NO1	1	A1	I/O	Normally open switch path 1
NO2	5	D2	I/O	Normally open switch path 2
V+	8	A2	PWR	Power supply pin

6 Specifications

6.1 Absolute Maximum Ratings

over operating free-air temperature range (unless otherwise noted)⁽¹⁾⁽²⁾

		MIN	MAX	UNIT
V ₊	Supply voltage ⁽³⁾	-0.5	6.5	V
V _{NO} V _{COM}	Analog voltage ⁽³⁾⁽⁴⁾⁽⁵⁾	-0.5	V ₊ + 0.5	V
I _K	Analog port diode current	V _{NO} , V _{COM} < 0		mA
I _{NO}	ON-state switch current	V _{NO} , V _{COM} = 0 to V ₊		mA
I _{COM}	ON-state peak switch current ⁽⁶⁾	V _{NO} , V _{COM} = 0 to V ₊		mA
V _I	Digital input voltage ⁽³⁾⁽⁴⁾	-0.5	6.5	V
I _{IK}	Digital input clamp current	V _I < 0		mA
I ₊	Continuous current through V ₊		100	mA
I _{GND}	Continuous current through GND	-100	100	mA

- (1) Stresses beyond those listed under *Absolute Maximum Ratings* may cause permanent damage to the device. These are stress ratings only, and functional operation of the device at these or any other conditions beyond those indicated under *Recommended Operating Conditions* is not implied. Exposure to absolute-maximum-rated conditions for extended periods may affect device reliability.
- (2) The algebraic convention, whereby the most negative value is a minimum and the most positive value is a maximum.
- (3) All voltages are with respect to ground, unless otherwise specified.
- (4) The input and output voltage ratings may be exceeded if the input and output clamp-current ratings are observed.
- (5) This value is limited to 5.5 V maximum.
- (6) Pulse at 1-ms duration < 10% duty cycle.

6.2 ESD Ratings

		VALUE	UNIT
$V_{(ESD)}$ Electrostatic discharge	Human body model (HBM), per ANSI/ESDA/JEDEC JS-001 ⁽¹⁾	+2000	V
	Charged-device model (CDM), per JEDEC specification JESD22-C101 ⁽²⁾	+1000	

(1) JEDEC document JEP155 states that 500-V HBM allows safe manufacturing with a standard ESD control process.

(2) JEDEC document JEP157 states that 250-V CDM allows safe manufacturing with a standard ESD control process.

6.3 Recommended Operating Conditions

over operating free-air temperature range (unless otherwise noted)

		MIN	MAX	UNIT
$V_{I/O}$	Input/output voltage	0	V_+	V
V_+	Supply voltage	1.65	5.5	V
V_I	Control Input Voltage	0	5.5	V
T_A	Operating free-air temperature	–40	85	°C

6.4 Thermal Information

THERMAL METRIC ⁽¹⁾	TS5A23166			UNIT
	DCU (VSSOP)	YZP (DSBGA)	YZT (DSBGA)	
	8 PINS	8 PINS	8 PINS	
$R_{\theta JA}$ Junction-to-ambient thermal resistance	227	102	102	°C/W

(1) For more information about traditional and new thermal metrics, see the *IC Package Thermal Metrics* application report, [SPRA953](#).

6.5 Electrical Characteristics: 5-V Supply

$V_+ = 4.5\text{ V to }5.5\text{ V}$, $T_A = -40^\circ\text{C to }85^\circ\text{C}$ (unless otherwise noted)⁽¹⁾

PARAMETER	TEST CONDITIONS	T_A	V_+	MIN	TYP	MAX	UNIT
Analog Switch							
V_{COM}, V_{NO}	Analog signal			0		V_+	V
r_{peak}	Peak ON resistance	$0 \leq V_{NO} \leq V_+$, $I_{COM} = -100\text{ mA}$, Switch ON, see Figure 11	25°C Full	4.5 V	0.9	1.1 1.2	Ω
r_{on}	ON-state resistance	$V_{NO} = 2.5\text{ V}$, $I_{COM} = -100\text{ mA}$, Switch ON, see Figure 11	25°C Full	4.5 V	0.75	0.9 1	Ω
Δr_{on}	ON-state resistance match between channels	$V_{NO} = 2.5\text{ V}$, $I_{COM} = -100\text{ mA}$, Switch ON, see Figure 11	25°C Full	4.5 V	0.04	0.1 0.1	Ω
$r_{on(flat)}$	ON-state resistance flatness	$0 \leq V_{NO} \leq V_+$, $I_{COM} = -100\text{ mA}$, Switch ON, see Figure 11	25°C Full	4.5 V	0.2	0.15 0.25 0.25	Ω
$I_{NO(OFF)}$	NO OFF leakage current	$V_{NO} = 1\text{ V}$, $V_{COM} = 4.5\text{ V}$, or $V_{NO} = 4.5\text{ V}$, $V_{COM} = 1\text{ V}$, Switch OFF, see Figure 12	25°C Full	5.5 V	0 V	4 150	nA
$I_{NO(PWROFF)}$		$V_{NO} = 0\text{ to }5.5\text{ V}$, $V_{COM} = 5.5\text{ V to }0$, Switch OFF, see Figure 12	25°C Full	0 V	–10 –50	0.2 50	μA

(1) The algebraic convention, whereby the most negative value is a minimum and the most positive value is a maximum.

Electrical Characteristics: 5-V Supply (continued)
 $V_+ = 4.5\text{ V to }5.5\text{ V}$, $T_A = -40^\circ\text{C to }85^\circ\text{C}$ (unless otherwise noted)⁽¹⁾

PARAMETER		TEST CONDITIONS		T_A	V_+	MIN	TYP	MAX	UNIT
$I_{COM(OFF)}$	COM OFF leakage current	$V_{COM} = 1\text{ V}$, $V_{NO} = 4.5\text{ V}$, or $V_{COM} = 4.5\text{ V}$, $V_{NO} = 1\text{ V}$,	Switch OFF, see Figure 12	25°C	5.5 V	0 V	4	20	nA
				Full		-150		150	
$I_{COM(PWROFF)}$		$V_{COM} = 0\text{ to }5.5\text{ V}$, $V_{NO} = 5.5\text{ V to }0$,	Switch OFF, see Figure 12	25°C	0 V	-10	0.2	10	μA
				Full		-50		50	
$I_{NO(ON)}$	NO ON leakage current	$V_{NO} = 1\text{ V}$, $V_{COM} = \text{Open}$, or $V_{NO} = 4.5\text{ V}$, $V_{COM} = \text{Open}$,	Switch ON, see Figure 13	25°C	5.5 V	-5	0.4	5	nA
				Full		-50		50	
$I_{COM(ON)}$	COM ON leakage current	$V_{COM} = 1\text{ V}$, $V_{NO} = \text{Open}$, or $V_{COM} = 4.5\text{ V}$, $V_{NO} = \text{Open}$,	Switch ON, see Figure 13	25°C	5.5 V	-5	0.4	5	nA
				Full		-50		50	
Digital Control Inputs (IN1, IN2)⁽²⁾									
V_{IH}	Input logic high			Full		2.4		5.5	V
V_{IL}	Input logic low			Full		0		0.8	V
I_{IH}, I_{IL}	Input leakage current	$V_I = 5.5\text{ V or }0$		25°C	5.5 V	-2	0.3	2	nA
				Full		-20		20	
Dynamic									
Q_C	Charge injection	$V_{GEN} = 0$, $R_{GEN} = 0$,	$C_L = 1\text{ nF}$, see Figure 19	25°C	5 V		6		pC
$C_{NO(OFF)}$	NO OFF capacitance	$V_{NO} = V_+ \text{ or GND}$, Switch OFF,	See Figure 14	25°C	5 V		19		pF
$C_{COM(OFF)}$	COM OFF capacitance	$V_{COM} = V_+ \text{ or GND}$, Switch OFF,	See Figure 14	25°C	5 V		18		pF
$C_{NO(ON)}$	NO ON capacitance	$V_{NO} = V_+ \text{ or GND}$, Switch ON,	See Figure 14	25°C	5 V		35.5		pF
$C_{COM(ON)}$	COM ON capacitance	$V_{COM} = V_+ \text{ or GND}$, Switch ON,	See Figure 14	25°C	5 V		35.5		pF
C_I	Digital input capacitance	$V_I = V_+ \text{ or GND}$,	See Figure 14	25°C	5 V		2		pF
BW	Bandwidth	$R_L = 50\ \Omega$, Switch ON,	See Figure 16	25°C	5 V		150		MHz
O_{ISO}	OFF isolation	$R_L = 50\ \Omega$, $f = 1\text{ MHz}$,	Switch OFF, see Figure 17	25°C	5 V		-62		dB
X_{TALK}	Crosstalk	$R_L = 50\ \Omega$, $f = 1\text{ MHz}$,	Switch ON, see Figure 18	25°C	5 V		-85		dB
THD	Total harmonic distortion	$R_L = 600\ \Omega$, $C_L = 50\text{ pF}$,	$f = 20\text{ Hz to }20\text{ kHz}$, see Figure 20	25°C	5 V		0.00 5%		

(2) All unused digital inputs of the device must be held at V_+ or GND to ensure proper device operation. Refer to the TI application report, *Implications of Slow or Floating CMOS Inputs*, literature number [SCBA004](#).

Electrical Characteristics: 5-V Supply (continued)
 $V_+ = 4.5\text{ V to }5.5\text{ V}$, $T_A = -40^\circ\text{C to }85^\circ\text{C}$ (unless otherwise noted)⁽¹⁾

PARAMETER		TEST CONDITIONS		T_A	V_+	MIN	TYP	MAX	UNIT
Supply									
I_+	Positive supply current	$V_I = V_+$ or GND,	Switch ON or OFF	25°C	5.5 V	0.01	0.1	1	μA
				Full					

6.6 Electrical Characteristics: 3.3-V Supply
 $V_+ = 3\text{ V to }3.6\text{ V}$, $T_A = -40^\circ\text{C to }85^\circ\text{C}$ (unless otherwise noted)⁽¹⁾

PARAMETER		TEST CONDITIONS		T_A	V_+	MIN	TYP	MAX	UNIT
Analog Switch									
$V_{\text{COM}}, V_{\text{NO}}$	Analog signal range					0		V_+	V
r_{peak}	Peak ON resistance	$0 \leq V_{\text{NO}} \leq V_+$, $I_{\text{COM}} = -100\text{ mA}$,	Switch ON, see Figure 11	25°C	3 V	1.3	1.6	1.8	Ω
				Full					
r_{on}	ON-state resistance	$V_{\text{NO}} = 2\text{ V}$, $I_{\text{COM}} = -100\text{ mA}$,	Switch ON, see Figure 11	25°C	3 V	1.1	1.5	1.7	Ω
				Full					
Δr_{on}	ON-state resistance match between channels	$V_{\text{NO}} = 2\text{ V}, 0.8\text{ V}$, $I_{\text{COM}} = -100\text{ mA}$,	Switch ON, see Figure 11	25°C	3 V	0.04	0.1	0.1	Ω
				Full					
$r_{\text{on(flat)}}$	ON-state resistance flatness	$0 \leq V_{\text{NO}} \leq V_+$, $I_{\text{COM}} = -100\text{ mA}$	Switch ON, see Figure 11	25°C	3 V	0.3	0.15	0.25	Ω
				25°C					
				Full					
$I_{\text{NO(OFF)}}$	NO OFF leakage current	$V_{\text{NO}} = 1\text{ V}, V_{\text{COM}} = 3\text{ V}$, or $V_{\text{NO}} = 3\text{ V}, V_{\text{COM}} = 1\text{ V}$,	Switch OFF, see Figure 12	25°C	3.6 V	-5	0.5	5	nA
				Full					
$I_{\text{NO(PWROFF)}}$		$V_{\text{NO}} = 0\text{ to }3.6\text{ V}$, $V_{\text{COM}} = 3.6\text{ V to }0$,	Switch OFF, see Figure 12	25°C	0 V	-5	0.1	5	μA
				Full					
$I_{\text{COM(OFF)}}$	COM OFF leakage current	$V_{\text{COM}} = 1\text{ V}, V_{\text{NO}} = 3\text{ V}$, or $V_{\text{COM}} = 3\text{ V}, V_{\text{NO}} = 1\text{ V}$,	Switch OFF, see Figure 12	25°C	3.6 V	-5	0.5	5	nA
				Full					
$I_{\text{COM(PWROFF)}}$		$V_{\text{COM}} = 0\text{ to }3.6\text{ V}$, $V_{\text{NO}} = 3.6\text{ V to }0$,	Switch OFF, see Figure 12	25°C	0 V	-5	0.1	5	μA
				Full					
$I_{\text{NO(ON)}}$	NO ON leakage current	$V_{\text{NO}} = 1\text{ V}$, $V_{\text{COM}} = \text{Open}$, or $V_{\text{NO}} = 3\text{ V}$, $V_{\text{COM}} = \text{Open}$,	Switch ON, see Figure 13	25°C	3.6 V	-2	0.3	2	nA
				Full					
$I_{\text{COM(ON)}}$	COM ON leakage current	$V_{\text{COM}} = 1\text{ V}$, $V_{\text{NO}} = \text{Open}$, or $V_{\text{COM}} = 3\text{ V}$, $V_{\text{NO}} = \text{Open}$,	Switch ON, see Figure 13	25°C	3.6 V	-2	0.3	2	nA
				Full					
Digital Control Inputs (IN1, IN2)⁽²⁾									
V_{IH}	Input logic high			Full		2		5.5	V
V_{IL}	Input logic low			Full		0		0.8	V
$I_{\text{IH}}, I_{\text{IL}}$	Input leakage current	$V_I = 5.5\text{ V or }0$		25°C	3.6 V	-2	0.3	2	nA
				Full					

(1) The algebraic convention, whereby the most negative value is a minimum and the most positive value is a maximum.

(2) All unused digital inputs of the device must be held at V_+ or GND to ensure proper device operation. Refer to the TI application report, *Implications of Slow or Floating CMOS Inputs*, literature number [SCBA004](#).

Electrical Characteristics: 3.3-V Supply (continued)
 $V_+ = 3\text{ V to }3.6\text{ V}$, $T_A = -40^\circ\text{C to }85^\circ\text{C}$ (unless otherwise noted)⁽¹⁾

PARAMETER		TEST CONDITIONS		T_A	V_+	MIN	TYP	MAX	UNIT
Dynamic									
Q_C	Charge injection	$V_{GEN} = 0$, $R_{GEN} = 0$,	$C_L = 1\text{ nF}$, see Figure 19	25°C	5 V		6		pC
$C_{NO(OFF)}$	NO OFF capacitance	$V_{NO} = V_+$ or GND, Switch OFF,	See Figure 14	25°C	3.3 V		19.5		pF
$C_{COM(OFF)}$	COM OFF capacitance	$V_{COM} = V_+$ or GND, Switch OFF,	See Figure 14	25°C	3.3 V		18.5		pF
$C_{NO(ON)}$	NO ON capacitance	$V_{NO} = V_+$ or GND, Switch ON,	See Figure 14	25°C	3.3 V		36		pF
$C_{COM(ON)}$	COM ON capacitance	$V_{COM} = V_+$ or GND, Switch ON,	See Figure 14	25°C	3.3 V		36		pF
C_I	Digital input capacitance	$V_I = V_+$ or GND,	See Figure 14	25°C	3.3 V		2		pF
BW	Bandwidth	$R_L = 50\ \Omega$, Switch ON,	See Figure 16	25°C	3.3 V		150		MHz
O_{ISO}	OFF isolation	$R_L = 50\ \Omega$, $f = 1\text{ MHz}$,	Switch OFF, see Figure 17	25°C	3.3 V		-62		dB
X_{TALK}	Crosstalk	$R_L = 50\ \Omega$, $f = 1\text{ MHz}$,	Switch ON, see Figure 18	25°C	3.3 V		-85		dB
THD	Total harmonic distortion	$R_L = 600\ \Omega$, $C_L = 50\text{ pF}$,	$f = 20\text{ Hz to }20\text{ kHz}$, see Figure 20	25°C	3.3 V		0.01 %		
Supply									
I_+	Positive supply current	$V_I = V_+$ or GND,	Switch ON or OFF	25°C	3.6 V	0.00	1	0.05	μA
				Full			0.3		

6.7 Electrical Characteristics: 2.5-V Supply
 $V_+ = 2.3\text{ V to }2.7\text{ V}$, $T_A = -40^\circ\text{C to }85^\circ\text{C}$ (unless otherwise noted)⁽¹⁾

PARAMETER		TEST CONDITIONS		T_A	V_+	MIN	TYP	MAX	UNIT
Analog Switch									
V_{COM}, V_{NO}	Analog signal range					0		V_+	V
r_{peak}	Peak ON resistance	$0 \leq V_{NO} \leq V_+$, $I_{COM} = -8\text{ mA}$,	Switch ON, see Figure 11	25°C	2.3 V	1.8	2.4		Ω
				Full			2.6		
r_{on}	ON-state resistance	$V_{NO} = 1.8\text{ V}$, $I_{COM} = -8\text{ mA}$,	Switch ON, see Figure 11	25°C	2.3 V	1.2	2.1		Ω
				Full			2.4		
Δr_{on}	ON-state resistance match between channels	$V_{NO} = 1.8\text{ V}, 0.8\text{ V}$, $I_{COM} = -8\text{ mA}$,	Switch ON, see Figure 11	25°C	2.3 V	0.04	0.15		Ω
				Full			0.15		
$r_{on(Flat)}$	ON-state resistance flatness	$0 \leq V_{NO} \leq V_+$, $I_{COM} = -8\text{ mA}$,	Switch ON, see Figure 11	25°C	2.3 V	0.7			Ω
				25°C		0.4	0.6		
				Full			0.6		

(1) The algebraic convention is used in this data sheet; the most negative value is shown in the minimum column.

Electrical Characteristics: 2.5-V Supply (continued)
 $V_+ = 2.3 \text{ V to } 2.7 \text{ V}$, $T_A = -40^\circ\text{C to } 85^\circ\text{C}$ (unless otherwise noted)⁽¹⁾

PARAMETER		TEST CONDITIONS		T_A	V_+	MIN	TYP	MAX	UNIT
$I_{\text{NO(OFF)}}$	NO OFF leakage current	$V_{\text{NO}} = 0.5 \text{ V}$, $V_{\text{COM}} = 2.3 \text{ V}$, or $V_{\text{NO}} = 2.3 \text{ V}$, $V_{\text{COM}} = 0.5 \text{ V}$,	Switch OFF, see Figure 12	25°C	2.7 V	-5	0.3	5	nA
				Full		-50		50	
$I_{\text{NO(PWROFF)}}$		$V_{\text{NO}} = 0 \text{ to } 2.7 \text{ V}$, $V_{\text{COM}} = 2.7 \text{ V to } 0$,	Switch OFF, see Figure 12	25°C	0 V	-2	0.05	2	μA
				Full		-15		15	
$I_{\text{COM(OFF)}}$	COM OFF leakage current	$V_{\text{NO}} = 2.3 \text{ V}$, $V_{\text{COM}} = 0.5 \text{ V}$, or $V_{\text{NO}} = 0.5 \text{ V}$, $V_{\text{COM}} = 2.3 \text{ V}$,	Switch OFF, see Figure 12	25°C	2.7 V	-5	0.3	5	nA
				Full		-50		50	
$I_{\text{COM(PWROFF)}}$		$V_{\text{COM}} = 0 \text{ to } 2.7 \text{ V}$, $V_{\text{NO}} = 2.7 \text{ V to } 0$,	Switch OFF, see Figure 12	25°C	0 V	-2	0.05	2	μA
				Full		-15		15	
$I_{\text{NO(ON)}}$	NO ON leakage current	$V_{\text{NO}} = 0.5 \text{ V}$, $V_{\text{COM}} = \text{Open}$, or $V_{\text{NO}} = 2.3 \text{ V}$, $V_{\text{COM}} = \text{Open}$,	Switch ON, see Figure 13	25°C	2.7 V	-2	0.3	2	nA
				Full		-20		20	
$I_{\text{COM(ON)}}$	COM ON leakage current	$V_{\text{COM}} = 0.5 \text{ V}$, $V_{\text{NO}} = \text{Open}$, or $V_{\text{COM}} = 2.3 \text{ V}$, $V_{\text{NO}} = \text{Open}$,	Switch ON, see Figure 13	25°C	2.7 V	-2	0.3	2	nA
				Full		-20		20	
Digital Control Inputs (IN1, IN2)									
V_{IH}	Input logic high			Full		1.8		5.5	V
V_{IL}	Input logic low			Full		0		0.6	V
$I_{\text{IH}}, I_{\text{IL}}$	Input leakage current	$V_{\text{I}} = 5.5 \text{ V or } 0$		25°C	2.7 V	-2	0.3	2	nA
				Full		-20		20	
Dynamic									
Q_{C}	Charge injection	$V_{\text{GEN}} = 0$, $R_{\text{GEN}} = 0$,	$C_{\text{L}} = 1 \text{ nF}$, see Figure 19	25°C	2.5 V		4		pC
$C_{\text{NO(OFF)}}$	NO OFF capacitance	$V_{\text{NO}} = V_+ \text{ or GND}$, Switch OFF,	See Figure 14	25°C	2.5 V		19.5		pF
$C_{\text{COM(OFF)}}$	COM OFF capacitance	$V_{\text{COM}} = V_+ \text{ or GND}$, Switch OFF,	See Figure 14	25°C	2.5 V		18.5		pF
$C_{\text{NO(ON)}}$	NO ON capacitance	$V_{\text{NO}} = V_+ \text{ or GND}$, Switch ON,	See Figure 14	25°C	2.5 V		36.5		pF
$C_{\text{COM(ON)}}$	COM ON capacitance	$V_{\text{COM}} = V_+ \text{ or GND}$, Switch ON,	See Figure 14	25°C	2.5 V		36.5		pF
C_{I}	Digital input capacitance	$V_{\text{I}} = V_+ \text{ or GND}$,	See Figure 14	25°C	2.5 V		2		pF
BW	Bandwidth	$R_{\text{L}} = 50 \Omega$, Switch ON,	See Figure 16	25°C	2.5 V		150		MHz
O_{ISO}	OFF isolation	$R_{\text{L}} = 50 \Omega$, $f = 1 \text{ MHz}$,	Switch OFF, see Figure 17	25°C	2.5 V		-62		dB
X_{TALK}	Crosstalk	$R_{\text{L}} = 50 \Omega$, $f = 1 \text{ MHz}$,	Switch ON, see Figure 18	25°C	2.5 V		-85		dB
THD	Total harmonic distortion	$R_{\text{L}} = 600 \Omega$, $C_{\text{L}} = 50 \text{ pF}$,	$f = 20 \text{ Hz to } 20 \text{ kHz}$, see Figure 20	25°C	2.5 V		0.02%		
Supply									

Electrical Characteristics: 2.5-V Supply (continued)
 $V_+ = 2.3 \text{ V to } 2.7 \text{ V}$, $T_A = -40^\circ\text{C to } 85^\circ\text{C}$ (unless otherwise noted)⁽¹⁾

PARAMETER	TEST CONDITIONS	T_A	V_+	MIN	TYP	MAX	UNIT
I_+	Positive supply current $V_I = V_+$ or GND, Switch ON or OFF	25°C	2.7 V	0.001	0.02	0.25	μA
		Full					

6.8 Electrical Characteristics: 1.8-V Supply
 $V_+ = 1.65 \text{ V to } 1.95 \text{ V}$, $T_A = -40^\circ\text{C to } 85^\circ\text{C}$ (unless otherwise noted)⁽¹⁾

PARAMETER	TEST CONDITIONS	T_A	V_+	MIN	TYP	MAX	UNIT
Analog Switch							
$V_{\text{COM}}, V_{\text{NO}}$	Analog signal range			0		V_+	V
r_{peak}	Peak ON resistance $0 \leq V_{\text{NO}} \leq V_+$, $I_{\text{COM}} = -2 \text{ mA}$, Switch ON, see Figure 11	25°C	1.65 V		4.2	25	Ω
		Full					
r_{on}	ON-state resistance $V_{\text{NO}} = 0.6 \text{ V}, 1.5 \text{ V}$, $I_{\text{COM}} = -2 \text{ mA}$, Switch ON, see Figure 11	25°C	1.65 V		1.6	3.9	Ω
		Full					
Δr_{on}	ON-state resistance match between channels $V_{\text{NO}} = 1.5 \text{ V}$, $I_{\text{COM}} = -2 \text{ mA}$, Switch ON, see Figure 11	25°C	1.65 V		0.04	0.2	Ω
		Full					
$r_{\text{on(Flat)}}$	ON-state resistance flatness $0 \leq V_{\text{NO}} \leq V_+$, $I_{\text{COM}} = -2 \text{ mA}$, Switch ON, see Figure 11	25°C	1.65 V		2.8	22	Ω
		25°C					
		Full					
$I_{\text{NO(OFF)}}$	NO OFF leakage current $V_{\text{NO}} = 0.3 \text{ V}$, $V_{\text{COM}} = 1.65 \text{ V}$, or $V_{\text{NO}} = 1.65 \text{ V}$, $V_{\text{COM}} = 0.3 \text{ V}$, Switch OFF, see Figure 12	25°C	1.95 V		-5	0.3	5
		Full					
$I_{\text{NO(PWROFF)}}$	NO OFF leakage current $V_{\text{NO}} = 0 \text{ to } 1.95 \text{ V}$, $V_{\text{COM}} = 1.95 \text{ V to } 0$, Switch OFF, see Figure 12	25°C	0 V		-2	0.05	2
		Full					
$I_{\text{COM(OFF)}}$	COM OFF leakage current $V_{\text{NO}} = 1.65 \text{ V}$, $V_{\text{COM}} = 0.3 \text{ V}$, or $V_{\text{NO}} = 0.3 \text{ V}$, $V_{\text{COM}} = 1.65 \text{ V}$, Switch OFF, see Figure 12	25°C	1.95 V		-5	0.3	5
		Full					
$I_{\text{COM(PWROFF)}}$	COM OFF leakage current $V_{\text{COM}} = 0 \text{ to } 1.95 \text{ V}$, $V_{\text{NO}} = 1.95 \text{ V to } 0$, Switch OFF, see Figure 12	25°C	0 V		-2	0.05	2
		Full					
$I_{\text{NO(ON)}}$	NO ON leakage current $V_{\text{NO}} = 0.3 \text{ V}$, $V_{\text{COM}} = \text{Open}$, or $V_{\text{NO}} = 1.65 \text{ V}$, $V_{\text{COM}} = \text{Open}$, Switch ON, see Figure 13	25°C	1.95 V		-2	0.3	2
		Full					
$I_{\text{COM(ON)}}$	COM ON leakage current $V_{\text{NO}} = \text{Open}$, $V_{\text{COM}} = 0.3 \text{ V}$, or $V_{\text{NO}} = \text{Open}$, $V_{\text{COM}} = 1.65 \text{ V}$, Switch ON, see Figure 13	25°C	1.95 V		-2	0.3	2
		Full					
Digital Control Inputs (IN1, IN2)							
V_{IH}	Input logic high		Full		1.5	5.5	V
V_{IL}	Input logic low		Full		0	0.6	V
$I_{\text{IH}}, I_{\text{IL}}$	Input leakage current $V_I = 5.5 \text{ V or } 0$	25°C	1.95 V		-2	0.3	2
		Full					
Dynamic							

(1) The algebraic convention is used in this data sheet; the most negative value is shown in the minimum column.

Electrical Characteristics: 1.8-V Supply (continued)
 $V_+ = 1.65\text{ V to }1.95\text{ V}$, $T_A = -40^\circ\text{C to }85^\circ\text{C}$ (unless otherwise noted)⁽¹⁾

PARAMETER		TEST CONDITIONS		T_A	V_+	MIN	TYP	MAX	UNIT
Q_C	Charge injection	$V_{GEN} = 0$, $R_{GEN} = 0$,	$C_L = 1\text{ nF}$, see Figure 19	25°C	1.8 V		2		pC
$C_{NO(OFF)}$	NO OFF capacitance	$V_{NO} = V_+$ or GND, Switch OFF,	See Figure 14	25°C	1.8 V		19.5		pF
$C_{COM(OFF)}$	COM OFF capacitance	$V_{COM} = V_+$ or GND, Switch OFF,	See Figure 14	25°C	1.8 V		18.5		pF
$C_{NO(ON)}$	NO ON capacitance	$V_{NO} = V_+$ or GND, Switch ON,	See Figure 14	25°C	1.8 V		36.5		pF
$C_{COM(ON)}$	COM ON capacitance	$V_{COM} = V_+$ or GND, Switch ON,	See Figure 14	25°C	1.8 V		36.5		pF
C_I	Digital input capacitance	$V_I = V_+$ or GND,	See Figure 14	25°C	1.8 V		2		pF
BW	Bandwidth	$R_L = 50\ \Omega$, Switch ON,	See Figure 16	25°C	1.8 V		150		MHz
O_{ISO}	OFF isolation	$R_L = 50\ \Omega$, $f = 1\text{ MHz}$,	Switch OFF, see Figure 17	25°C	1.8 V		-62		dB
THD	Total harmonic distortion	$R_L = 600\ \Omega$, $C_L = 50\text{ pF}$,	$f = 20\text{ Hz to }20\text{ kHz}$, see Figure 20	25°C	1.8 V		0.055 %		
Supply									
I_+	Positive supply current	$V_I = V_+$ or GND,	Switch ON or OFF	25°C	1.95 V		0.001	0.01	μA
				Full				0.15	

6.9 Switching Characteristics: 5-V Supply
 $V_+ = 4.5\text{ V to }5.5\text{ V}$, $T_A = -40^\circ\text{C to }85^\circ\text{C}$ (unless otherwise noted)⁽¹⁾

PARAMETER		TEST CONDITIONS		T_A	V_+	MIN	TYP	MAX	UNIT
Dynamic									
t_{ON}	Turnon time	$V_{COM} = V_+$, $R_L = 50\ \Omega$,	$C_L = 35\text{ pF}$, see Figure 15	25°C	5 V	1	4.5	7.5	ns
				Full	4.5 V to 5.5 V	1		9	
t_{OFF}	Turnoff time	$V_{COM} = V_+$, $R_L = 50\ \Omega$,	$C_L = 35\text{ pF}$, see Figure 15	25°C	5 V	4.5	8	11	ns
				Full	4.5 V to 5.5 V	3.5		13	

(1) The algebraic convention is used in this data sheet; the most negative value is shown in the minimum column.

6.10 Switching Characteristics: 3.3-V Supply
 $V_+ = 3\text{ V to }3.6\text{ V}$, $T_A = -40^\circ\text{C to }85^\circ\text{C}$ (unless otherwise noted)⁽¹⁾

PARAMETER		TEST CONDITIONS		T_A	V_+	MIN	TYP	MAX	UNIT
Dynamic									
t_{ON}	Turnon time	$V_{COM} = V_+$, $R_L = 50\ \Omega$,	$C_L = 35\text{ pF}$, see Figure 15	25°C	3.3 V	1.5	5	9.5	ns
				Full	3 V to 3.6 V	1		10	
t_{OFF}	Turnoff time	$V_{COM} = V_+$, $R_L = 50\ \Omega$,	$C_L = 35\text{ pF}$, see Figure 15	25°C	3.3 V	4.5	8.5	11	ns
				Full	3 V to 3.6 V	3		12.5	

(1) The algebraic convention is used in this data sheet; the most negative value is shown in the minimum column.

6.11 Switching Characteristics: 2.5-V Supply

 $V_+ = 2.3 \text{ V to } 2.7 \text{ V}$, $T_A = -40^\circ\text{C to } 85^\circ\text{C}$ (unless otherwise noted)⁽¹⁾

PARAMETER		TEST CONDITIONS		T_A	V_+	MIN	TYP	MAX	UNIT
Dynamic									
t_{ON}	Turnon time	$V_{COM} = V_+$, $R_L = 50 \Omega$,	$C_L = 35 \text{ pF}$, see Figure 15	25°C	2.5 V	2	6	10	ns
				Full	2.3 V to 2.7 V	1		12	
t_{OFF}	Turnoff time	$V_{COM} = V_+$, $R_L = 50 \Omega$,	$C_L = 35 \text{ pF}$, see Figure 15	25°C	2.5 V	4.5	8	12.5	ns
				Full	2.3 V to 2.7 V	3		15	

(1) The algebraic convention is used in this data sheet; the most negative value is shown in the minimum column.

6.12 Switching Characteristics: 1.8-V Supply

 $V_+ = 1.65 \text{ V to } 1.95 \text{ V}$, $T_A = -40^\circ\text{C to } 85^\circ\text{C}$ (unless otherwise noted)⁽¹⁾

PARAMETER		TEST CONDITIONS		T_A	V_+	MIN	TYP	MAX	UNIT
Dynamic									
t_{ON}	Turnon time	$V_{COM} = V_+$, $R_L = 50 \Omega$,	$C_L = 35 \text{ pF}$, see Figure 15	25°C	1.8 V	3	9	18	ns
				Full	1.65 V to 1.95 V	1		20	
t_{OFF}	Turnoff time	$V_{COM} = V_+$, $R_L = 50 \Omega$,	$C_L = 35 \text{ pF}$, see Figure 15	25°C	1.8 V	5	10	15.5	ns
				Full	1.65 V to 1.95 V	4		18.5	

(1) The algebraic convention is used in this data sheet; the most negative value is shown in the minimum column.

6.13 Typical Characteristics

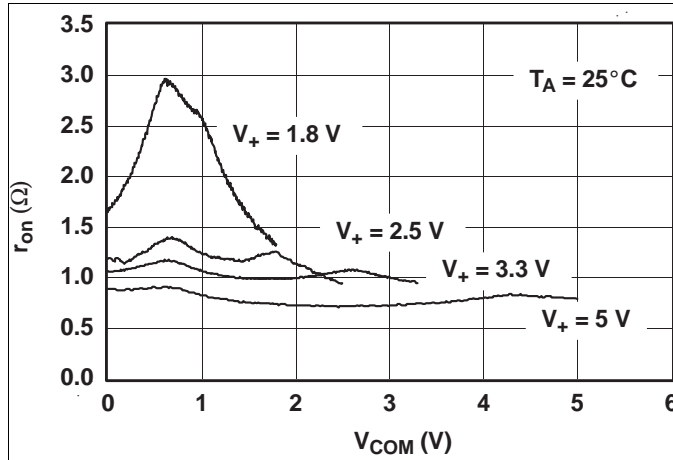

Figure 1. r_{on} vs V_{COM}

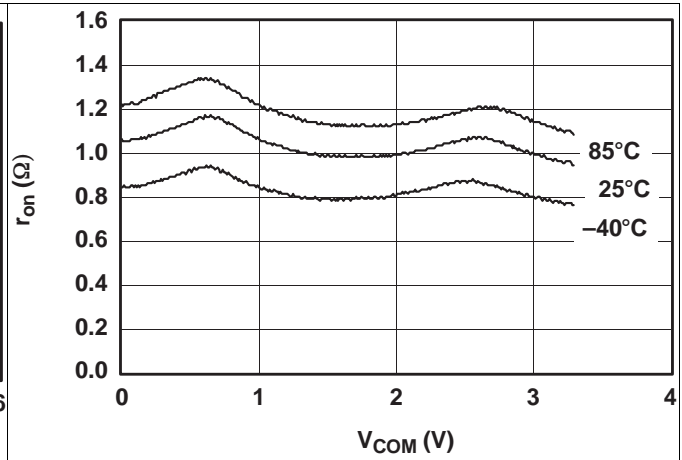

Figure 2. r_{on} vs V_{COM} ($V_+ = 3.3$ V)

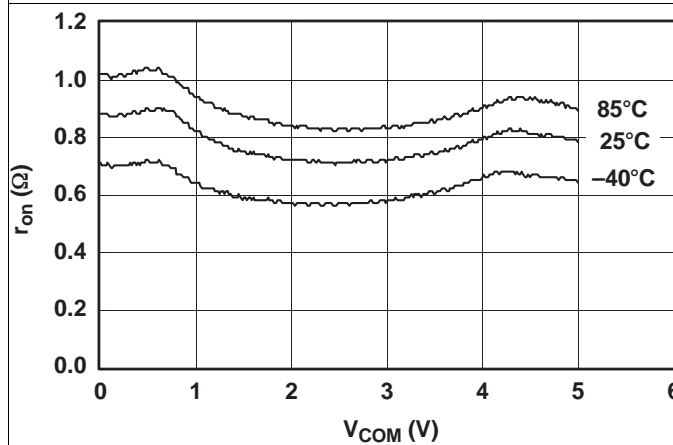

Figure 3. r_{on} vs V_{COM} ($V_+ = 5$ V)

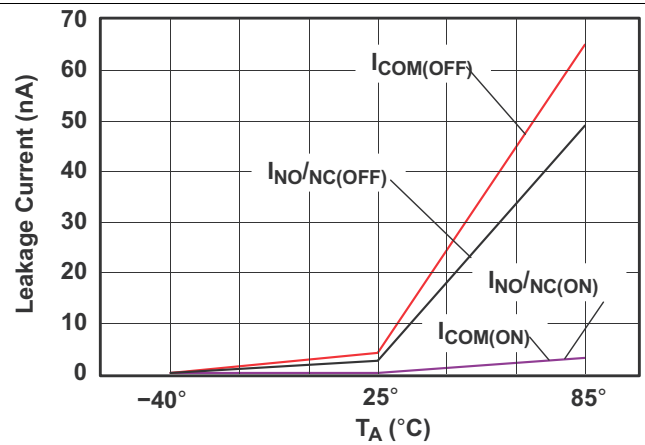

Figure 4. Leakage Current vs Temperature ($V_+ = 5.5$ V)

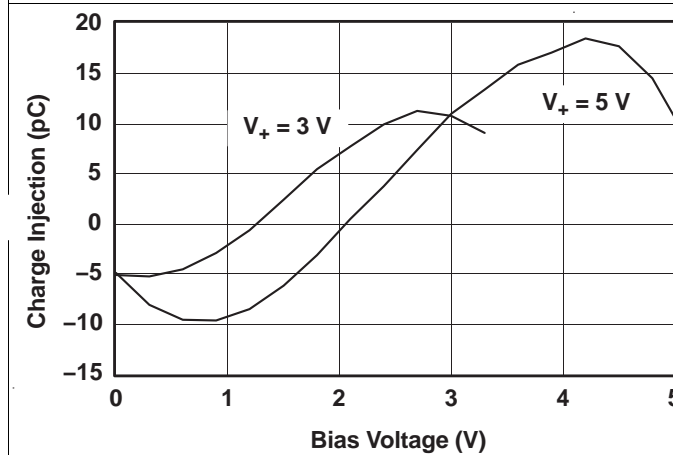

Figure 5. Charge Injection (Q_C) vs V_{COM}

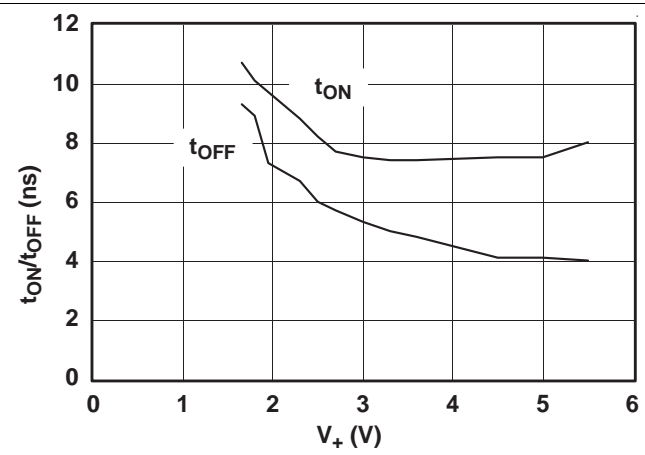

Figure 6. t_{ON} and t_{OFF} vs Supply Voltage

Typical Characteristics (continued)

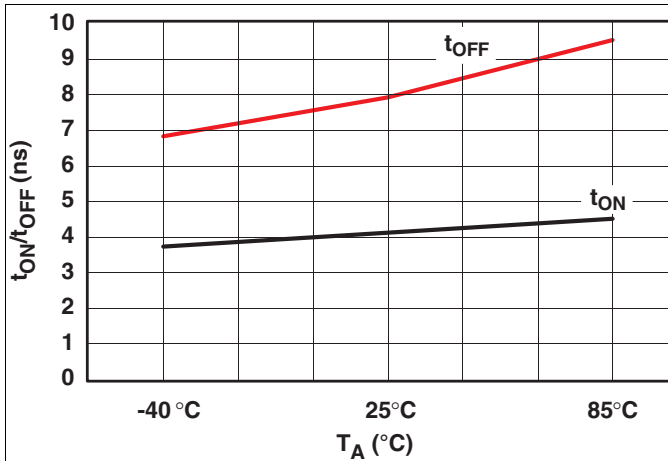

Figure 7. t_{ON} and t_{OFF} vs Temperature (V₊ = 5 V)

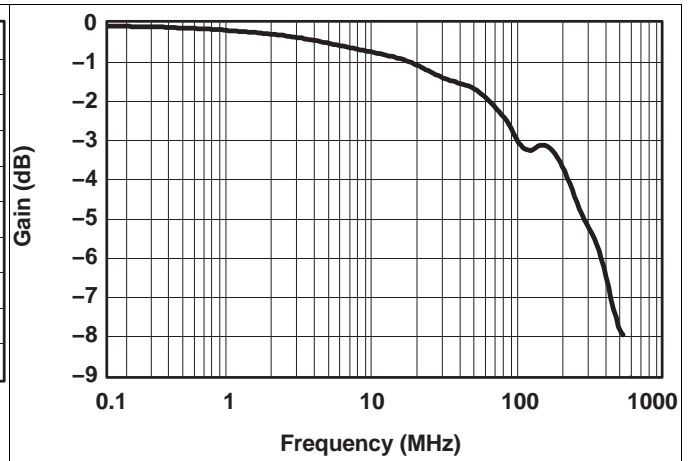

Figure 8. Bandwidth (V₊ = 5 V)

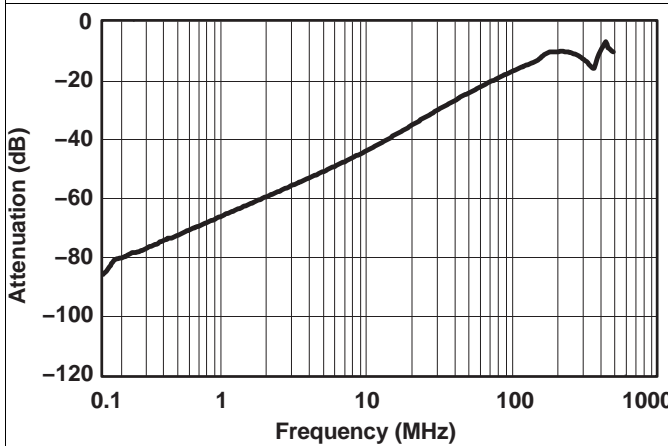

Figure 9. OFF Isolation and Crosstalk (V₊ = 5 V)

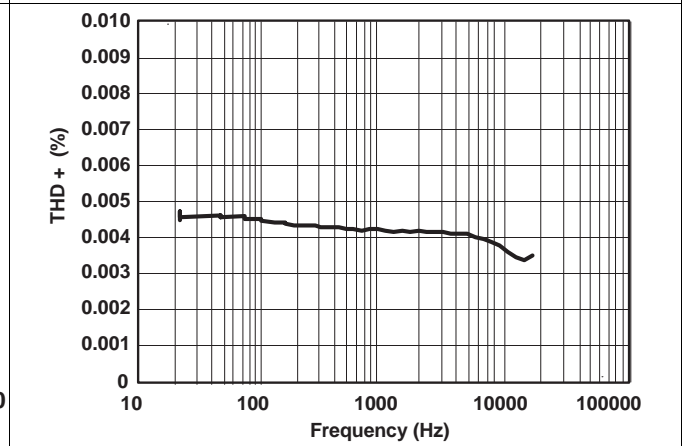

Figure 10. Total Harmonic Distortion vs Frequency

7 Parameter Measurement Information

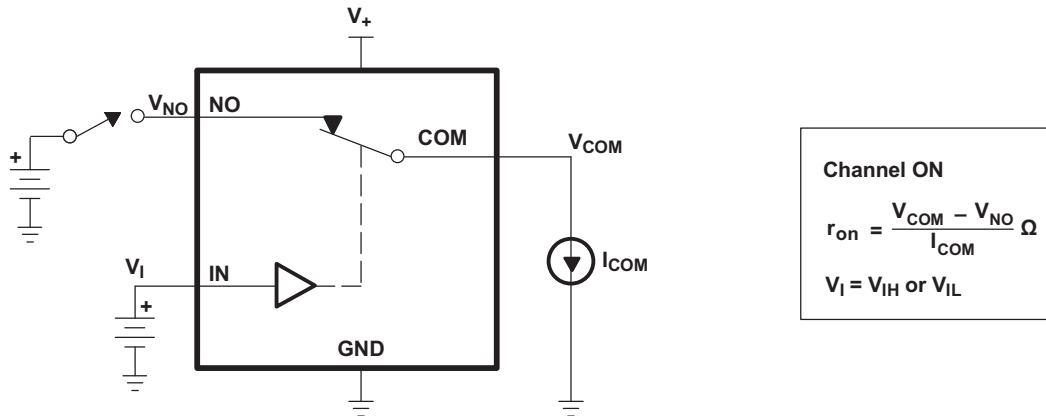

Figure 11. ON-State Resistance (r_{on})

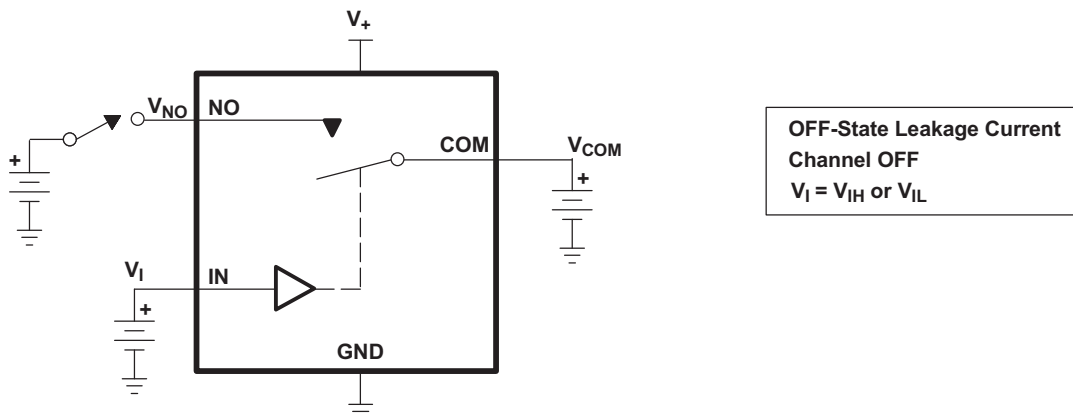

Figure 12. OFF-State Leakage Current ($I_{COM(OFF)}$, $I_{NC(OFF)}$, $I_{COM(PWROFF)}$, $I_{NC(PWROFF)}$)

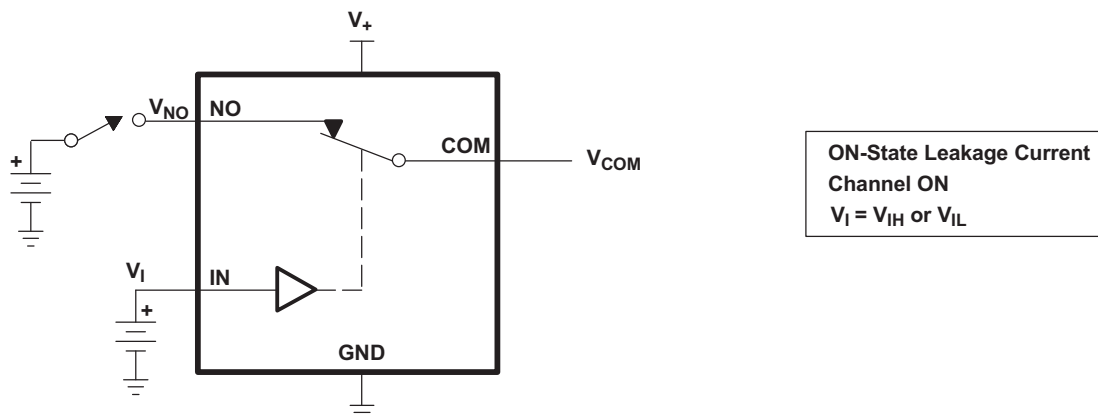

Figure 13. ON-State Leakage Current ($I_{COM(ON)}$, $I_{NC(ON)}$)

Parameter Measurement Information (continued)

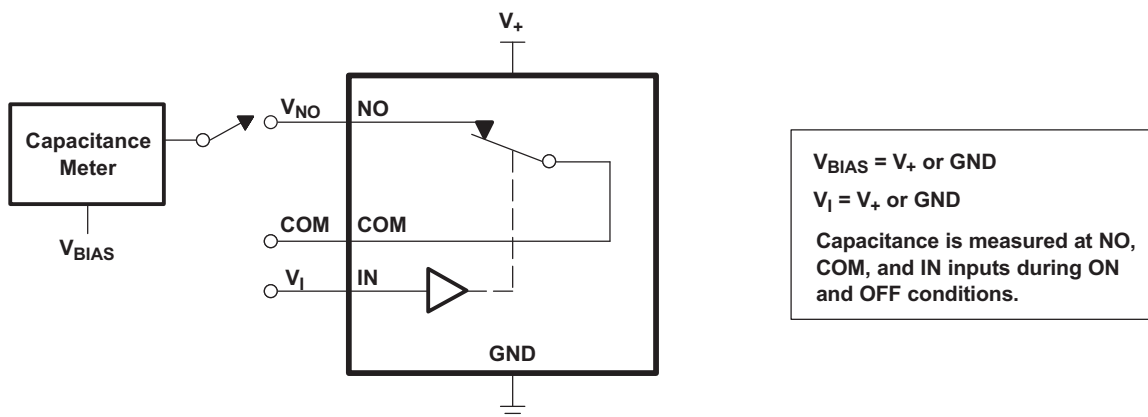
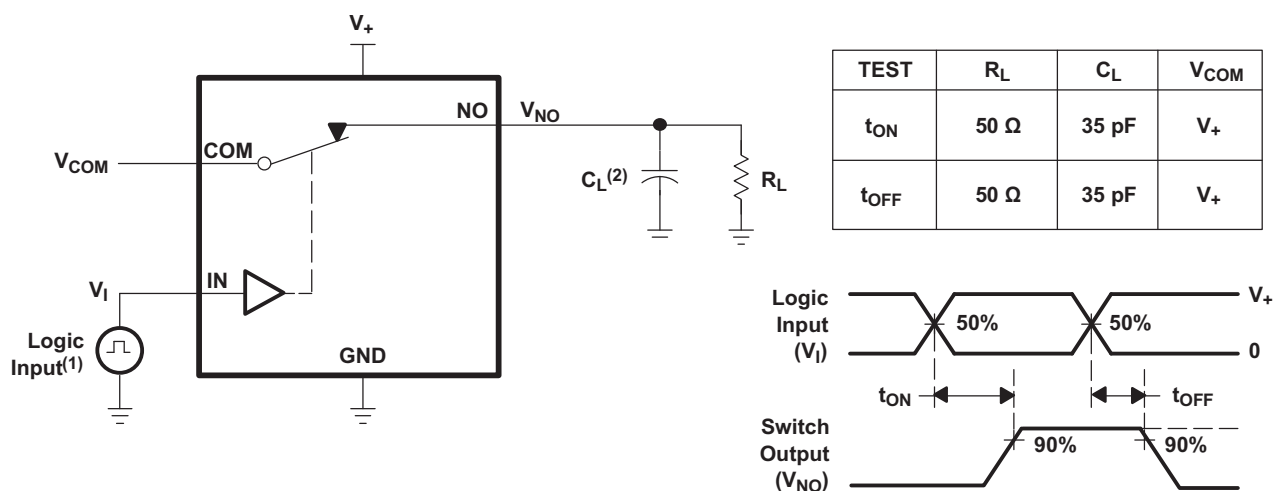

Figure 14. Capacitance (C_I , $C_{COM(OFF)}$, $C_{COM(ON)}$, $C_{NC(OFF)}$, $C_{NC(ON)}$)



- (1) All input pulses are supplied by generators having the following characteristics: PRR \leq 10 MHz, $Z_O = 50 \Omega$, $t_r < 5$ ns, $t_f < 5$ ns.
- (2) C_L includes probe and jig capacitance.

Figure 15. Turnon (t_{ON}) and Turnoff Time (t_{OFF})

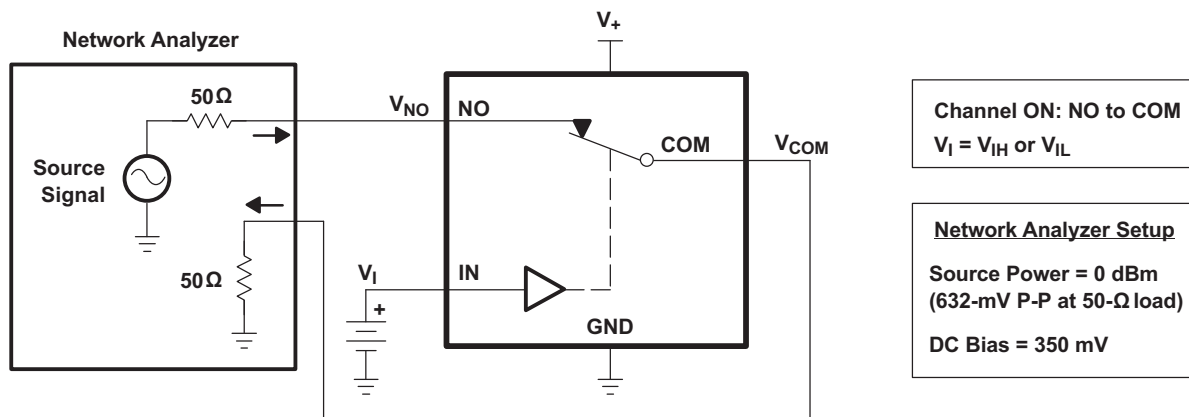

Figure 16. Bandwidth (BW)

Parameter Measurement Information (continued)

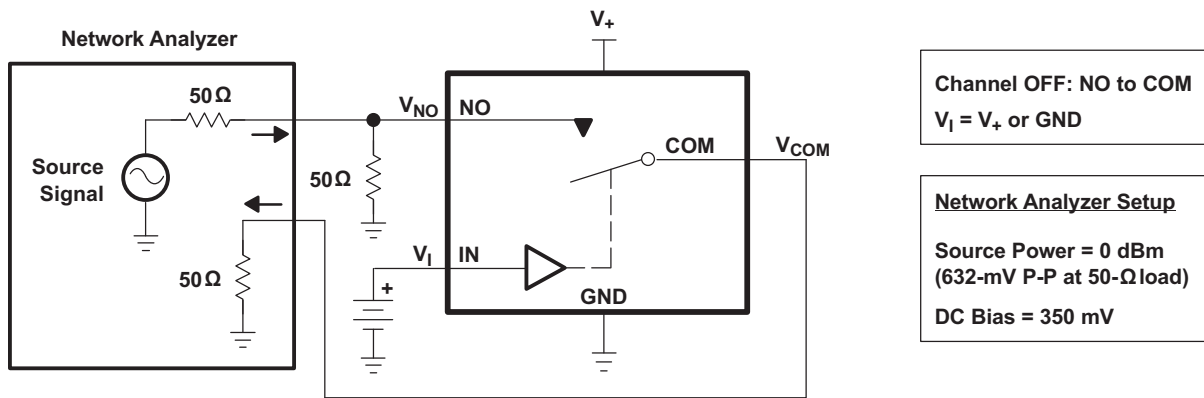

Figure 17. OFF Isolation (O_{ISO})

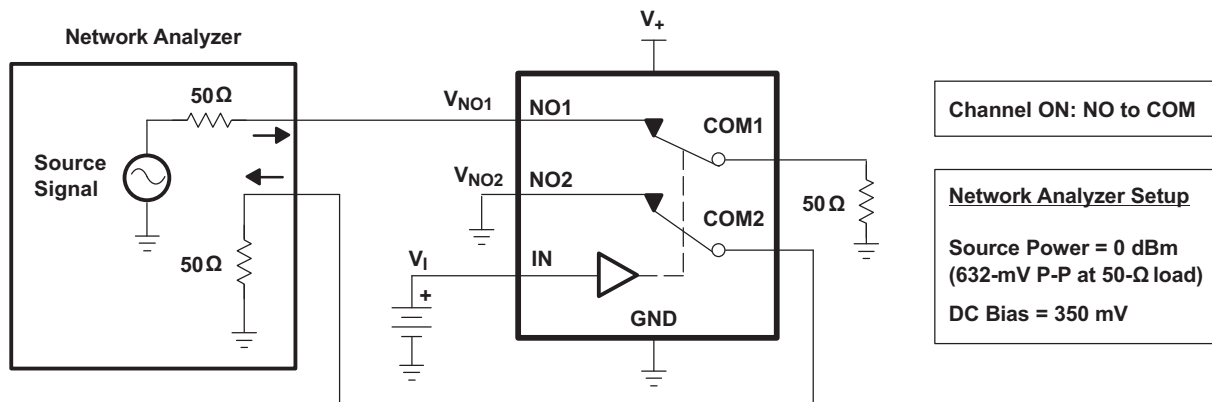
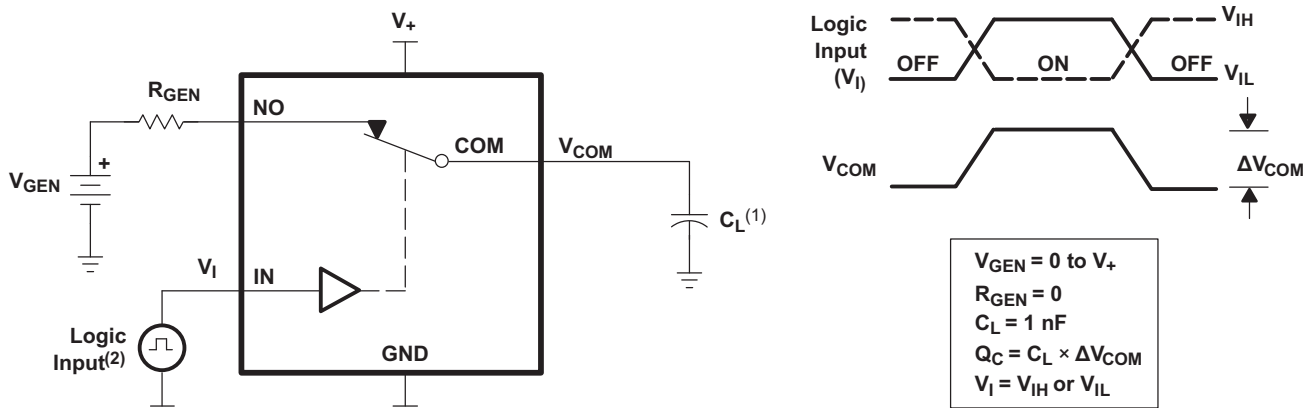

Figure 18. Crosstalk (X_{TALK})



- (1) C_L includes probe and jig capacitance.
- (2) All input pulses are supplied by generators having the following characteristics:
 PRR \leq 10 MHz, $Z_O = 50 \Omega$, $t_r < 5 \text{ ns}$, $t_f < 5 \text{ ns}$.

Figure 19. Charge Injection (Q_C)

Parameter Measurement Information (continued)

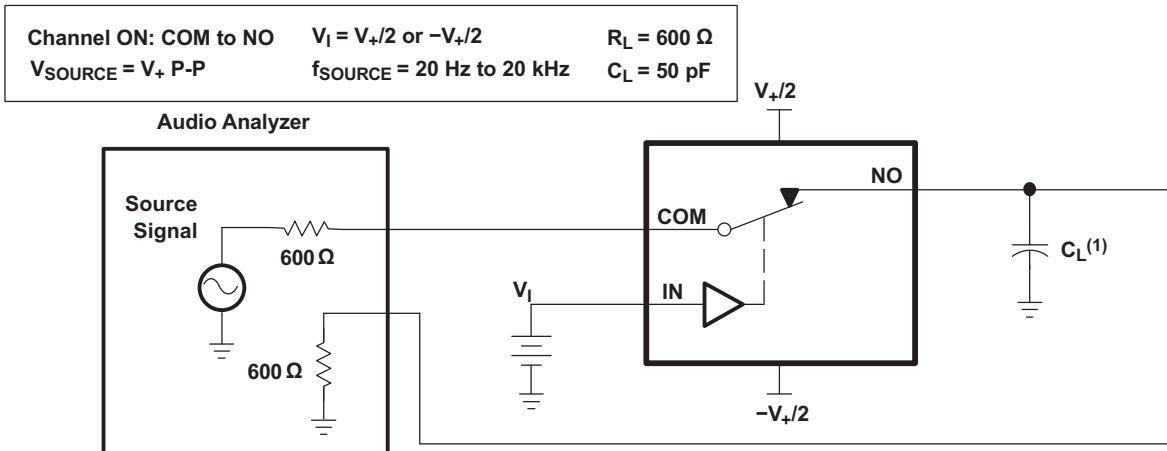

(1) C_L includes probe and jig capacitance.

Figure 20. Total Harmonic Distortion (THD)

8 Detailed Description

8.1 Overview

The TS5A23166 is a dual single-pole single-throw (SPST) analog switch that is designed to operate from 1.65 V to 5.5 V. The device offers a low ON-state resistance. The device has excellent total harmonic distortion (THD) performance and consumes very low power. These features make this device suitable for portable audio applications. [Table 2](#) shows the descriptions of each parameter specified in the datasheet.

8.2 Functional Block Diagram

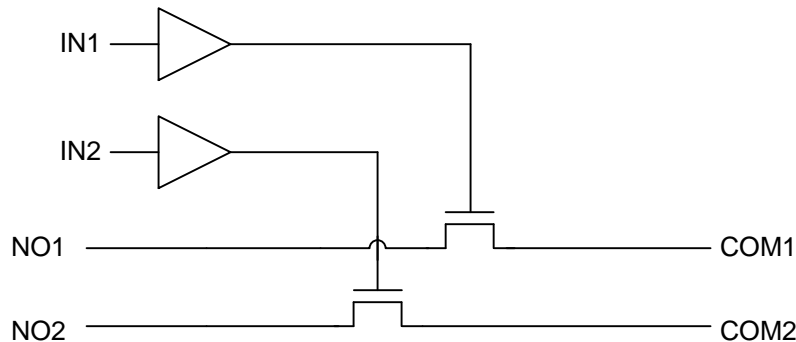

8.3 Feature Description

Tolerant control inputs allow 5-V logic levels to be present on the IN pin at any value of V_{CC} . Low ON-resistance allows minimal signal distortion through device.

8.4 Device Functional Modes

[Table 1](#) shows the functional modes for TS5A23166.

Table 1. Function Table

IN	NO TO COM, COM TO NO
L	OFF
H	ON

9 Application and Implementation

NOTE

Information in the following applications sections is not part of the TI component specification, and TI does not warrant its accuracy or completeness. TI's customers are responsible for determining suitability of components for their purposes. Customers should validate and test their design implementation to confirm system functionality.

9.1 Application Information

The TS5A23166 dual SPST analog switch is a basic component that could be used in any electrical system design. One example application is a gain selector, which is described in the *Typical Application* section.

9.2 Typical Application

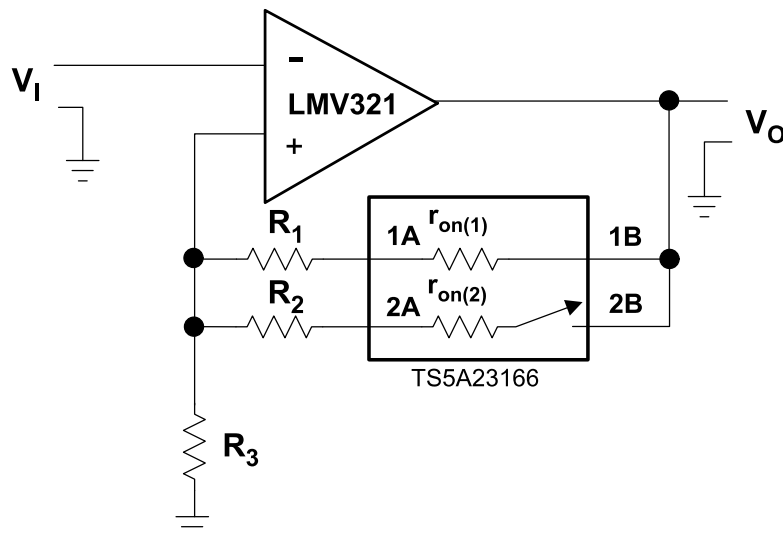

Figure 21. Gain-Control Circuit for OP Amplifier

9.2.1 Design Requirements

By selecting values of R_1 and R_2 , such that $R_x \gg r_{on(x)}$, r_{on} of TS5A23166 can be ignored. The gain of op amp can be calculated as follow:

$$V_o / V_i = 1 + R_{||} / R_3 \quad (1)$$

$$R_{||} = (R_1 + r_{on(1)}) || (R_2 + r_{on(2)}) \quad (2)$$

9.2.2 Detailed Design Procedure

Place a switch in series with the input of the op amp. Because the op amp input impedance is very large, a switch on $r_{on(1)}$ is irrelevant.

Typical Application (continued)

9.2.3 Application Curve

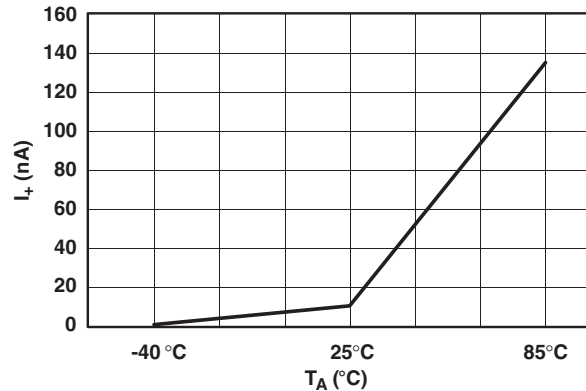

Figure 22. Power-Supply Current vs Temperature (V₊ = 5 V)

10 Power Supply Recommendations

The power supply can be any voltage between the minimum and maximum supply voltage rating located in the [Recommended Operating Conditions](#).

Each V_{CC} terminal should have a good bypass capacitor to prevent power disturbance. For devices with a single supply, a 0.1-μF bypass capacitor is recommended. If there are multiple pins labeled V_{CC}, then a 0.01-μF or 0.022-μF capacitor is recommended for each V_{CC} because the VCC pins will be tied together internally. For devices with dual supply pins operating at different voltages, for example V_{CC} and V_{DD}, a 0.1-μF bypass capacitor is recommended for each supply pin. It is acceptable to parallel multiple bypass capacitors to reject different frequencies of noise. 0.1-μF and 1-μF capacitors are commonly used in parallel. The bypass capacitor should be installed as close to the power terminal as possible for best results.

11 Layout

11.1 Layout Guidelines

Reflections and matching are closely related to loop antenna theory, but different enough to warrant their own discussion. When a PCB trace turns a corner at a 90° angle, a reflection can occur. This is primarily due to the change of width of the trace. At the apex of the turn, the trace width is increased to 1.414 times its width. This upsets the transmission line characteristics, especially the distributed capacitance and self-inductance of the trace — resulting in the reflection. It is a given that not all PCB traces can be straight, and so they will have to turn corners. [Figure 23](#) shows progressively better techniques of rounding corners. Only the last example maintains constant trace width and minimizes reflections.

11.2 Layout Example

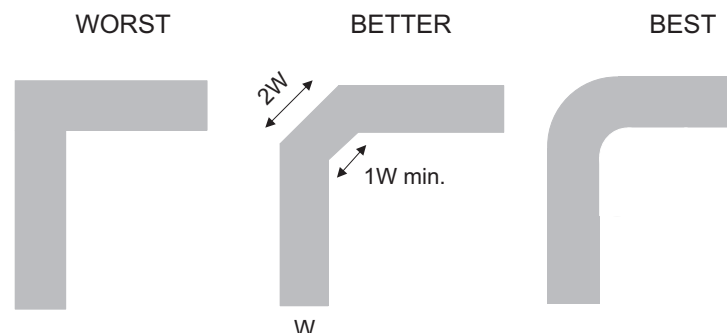

Figure 23. Trace Example

12 Device and Documentation Support

12.1 Device Support

12.1.1 Device Nomenclature

Table 2. Parameter Description

SYMBOL	DESCRIPTION
V_{COM}	Voltage at COM
V_{NO}	Voltage at NO
r_{on}	Resistance between COM and NO ports when the channel is ON
r_{peak}	Peak on-state resistance over a specified voltage range
$r_{on(Flat)}$	Difference between the maximum and minimum value of r_{on} in a channel over the specified range of conditions
$I_{NO(OFF)}$	Leakage current measured at the NO port, with the corresponding channel (NO to COM) in the OFF-state under worst-case input and output conditions
$I_{NO(PWROFF)}$	Leakage current measured at the NO port during the power-down condition, $V_+ = 0$
$I_{COM(OFF)}$	Leakage current measured at the COM port, with the corresponding channel (COM to NO) in the OFF-state under worst-case input and output conditions
$I_{COM(PWROFF)}$	Leakage current measured at the COM port during the power-down condition, $V_+ = 0$
$I_{NO(ON)}$	Leakage current measured at the NO port, with the corresponding channel (NO to COM) in the ON-state and the output (COM) open
$I_{COM(ON)}$	Leakage current measured at the COM port, with the corresponding channel (COM to NO) in the ON-state and the output (NO) open
V_{IH}	Minimum input voltage for logic high for the control input (IN)
V_{IL}	Maximum input voltage for logic low for the control input (IN)
V_I	Voltage at the control input (IN)
I_{IH}, I_{IL}	Leakage current measured at the control input (IN)
t_{ON}	Turnon time for the switch. This parameter is measured under the specified range of conditions and by the propagation delay between the digital control (IN) signal and analog output (COM or NO) signal when the switch is turning ON.
t_{OFF}	Turnoff time for the switch. This parameter is measured under the specified range of conditions and by the propagation delay between the digital control (IN) signal and analog output (COM or NO) signal when the switch is turning OFF.
Q_C	Charge injection is a measurement of unwanted signal coupling from the control (IN) input to the analog (NO or COM) output. This is measured in coulomb (C) and measured by the total charge induced due to switching of the control input. Charge injection, $Q_C = C_L \times \Delta V_{COM}$. C_L is the load capacitance, and ΔV_{COM} is the change in analog output voltage.
$C_{NO(OFF)}$	Capacitance at the NO port when the corresponding channel (NO to COM) is OFF
$C_{COM(OFF)}$	Capacitance at the COM port when the corresponding channel (COM to NO) is OFF
$C_{NO(ON)}$	Capacitance at the NO port when the corresponding channel (NO to COM) is ON
$C_{COM(ON)}$	Capacitance at the COM port when the corresponding channel (COM to NO) is ON
C_I	Capacitance of control input (IN)
O_{ISO}	OFF isolation of the switch is a measurement of OFF-state switch impedance. This is measured in dB in a specific frequency, with the corresponding channel (NO to COM) in the OFF state.
BW	Bandwidth of the switch. This is the frequency in which the gain of an ON channel is –3 dB below the DC gain.
THD	Total harmonic distortion describes the signal distortion caused by the analog switch. This is defined as the ratio of root mean square (RMS) value of the second, third, and higher harmonic to the absolute magnitude of the fundamental harmonic.
I_+	Static power-supply current with the control (IN) pin at V_+ or GND

12.2 Community Resources

The following links connect to TI community resources. Linked contents are provided "AS IS" by the respective contributors. They do not constitute TI specifications and do not necessarily reflect TI's views; see TI's [Terms of Use](#).

TI E2E™ Online Community *TI's Engineer-to-Engineer (E2E) Community*. Created to foster collaboration among engineers. At e2e.ti.com, you can ask questions, share knowledge, explore ideas and help solve problems with fellow engineers.

Design Support *TI's Design Support* Quickly find helpful E2E forums along with design support tools and contact information for technical support.

12.3 Trademarks

E2E is a trademark of Texas Instruments.
All other trademarks are the property of their respective owners.

12.4 Electrostatic Discharge Caution



These devices have limited built-in ESD protection. The leads should be shorted together or the device placed in conductive foam during storage or handling to prevent electrostatic damage to the MOS gates.

12.5 Glossary

[SLYZ022](#) — *TI Glossary*.

This glossary lists and explains terms, acronyms, and definitions.

13 Mechanical, Packaging, and Orderable Information

The following pages include mechanical, packaging, and orderable information. This information is the most current data available for the designated devices. This data is subject to change without notice and revision of this document. For browser-based versions of this data sheet, refer to the left-hand navigation.

PACKAGING INFORMATION

Orderable Device	Status (1)	Package Type	Package Drawing	Pins	Package Qty	Eco Plan (2)	Lead/Ball Finish (6)	MSL Peak Temp (3)	Op Temp (°C)	Device Marking (4/5)	Samples
TS5A23166DCUR	ACTIVE	VSSOP	DCU	8	3000	Green (RoHS & no Sb/Br)	CU NIPDAU CU SN	Level-1-260C-UNLIM	-40 to 85	(AM ~ JAMQ ~ JAMR) JZ	Samples
TS5A23166DCURE4	ACTIVE	VSSOP	DCU	8		TBD	Call TI	Call TI	-40 to 85		Samples
TS5A23166DCURG4	ACTIVE	VSSOP	DCU	8	3000	Green (RoHS & no Sb/Br)	CU NIPDAU	Level-1-260C-UNLIM	-40 to 85	JAMR	Samples
TS5A23166YZPR	ACTIVE	DSBGA	YZP	8	3000	Green (RoHS & no Sb/Br)	SNAGCU	Level-1-260C-UNLIM	-40 to 85	(JM7 ~ JMN)	Samples
TS5A23166YZTR	ACTIVE	DSBGA	YZT	8	3000	Green (RoHS & no Sb/Br)	SNAGCU	Level-1-260C-UNLIM	-40 to 85	(JM2 ~ JM7 ~ JMN)	Samples

(1) The marketing status values are defined as follows:

ACTIVE: Product device recommended for new designs.

LIFEBUY: TI has announced that the device will be discontinued, and a lifetime-buy period is in effect.

NRND: Not recommended for new designs. Device is in production to support existing customers, but TI does not recommend using this part in a new design.

PREVIEW: Device has been announced but is not in production. Samples may or may not be available.

OBSELETE: TI has discontinued the production of the device.

(2) Eco Plan - The planned eco-friendly classification: Pb-Free (RoHS), Pb-Free (RoHS Exempt), or Green (RoHS & no Sb/Br) - please check <http://www.ti.com/productcontent> for the latest availability information and additional product content details.

TBD: The Pb-Free/Green conversion plan has not been defined.

Pb-Free (RoHS): TI's terms "Lead-Free" or "Pb-Free" mean semiconductor products that are compatible with the current RoHS requirements for all 6 substances, including the requirement that lead not exceed 0.1% by weight in homogeneous materials. Where designed to be soldered at high temperatures, TI Pb-Free products are suitable for use in specified lead-free processes.

Pb-Free (RoHS Exempt): This component has a RoHS exemption for either 1) lead-based flip-chip solder bumps used between the die and package, or 2) lead-based die adhesive used between the die and leadframe. The component is otherwise considered Pb-Free (RoHS compatible) as defined above.

Green (RoHS & no Sb/Br): TI defines "Green" to mean Pb-Free (RoHS compatible), and free of Bromine (Br) and Antimony (Sb) based flame retardants (Br or Sb do not exceed 0.1% by weight in homogeneous material)

(3) MSL, Peak Temp. - The Moisture Sensitivity Level rating according to the JEDEC industry standard classifications, and peak solder temperature.

(4) There may be additional marking, which relates to the logo, the lot trace code information, or the environmental category on the device.

(5) Multiple Device Markings will be inside parentheses. Only one Device Marking contained in parentheses and separated by a "~" will appear on a device. If a line is indented then it is a continuation of the previous line and the two combined represent the entire Device Marking for that device.

⁽⁶⁾ Lead/Ball Finish - Orderable Devices may have multiple material finish options. Finish options are separated by a vertical ruled line. Lead/Ball Finish values may wrap to two lines if the finish value exceeds the maximum column width.

Important Information and Disclaimer:The information provided on this page represents TI's knowledge and belief as of the date that it is provided. TI bases its knowledge and belief on information provided by third parties, and makes no representation or warranty as to the accuracy of such information. Efforts are underway to better integrate information from third parties. TI has taken and continues to take reasonable steps to provide representative and accurate information but may not have conducted destructive testing or chemical analysis on incoming materials and chemicals. TI and TI suppliers consider certain information to be proprietary, and thus CAS numbers and other limited information may not be available for release.

In no event shall TI's liability arising out of such information exceed the total purchase price of the TI part(s) at issue in this document sold by TI to Customer on an annual basis.

TAPE AND REEL INFORMATION

QUADRANT ASSIGNMENTS FOR PIN 1 ORIENTATION IN TAPE

*All dimensions are nominal

Device	Package Type	Package Drawing	Pins	SPQ	Reel Diameter (mm)	Reel Width W1 (mm)	A0 (mm)	B0 (mm)	K0 (mm)	P1 (mm)	W (mm)	Pin1 Quadrant
TS5A23166DCUR	VSSOP	DCU	8	3000	180.0	9.0	2.05	3.3	1.0	4.0	8.0	Q3
TS5A23166DCURG4	VSSOP	DCU	8	3000	180.0	8.4	2.25	3.35	1.05	4.0	8.0	Q3
TS5A23166YZPR	DSBGA	YZP	8	3000	178.0	9.2	1.02	2.02	0.63	4.0	8.0	Q1
TS5A23166YZTR	DSBGA	YZT	8	3000	178.0	9.2	1.02	2.02	0.75	4.0	8.0	Q1

TAPE AND REEL BOX DIMENSIONS

*All dimensions are nominal

Device	Package Type	Package Drawing	Pins	SPQ	Length (mm)	Width (mm)	Height (mm)
TS5A23166DCUR	VSSOP	DCU	8	3000	182.0	182.0	20.0
TS5A23166DCURG4	VSSOP	DCU	8	3000	202.0	201.0	28.0
TS5A23166YZPR	DSBGA	YZP	8	3000	220.0	220.0	35.0
TS5A23166YZTR	DSBGA	YZT	8	3000	220.0	220.0	35.0

DCU (R-PDSO-G8)

PLASTIC SMALL-OUTLINE PACKAGE (DIE DOWN)

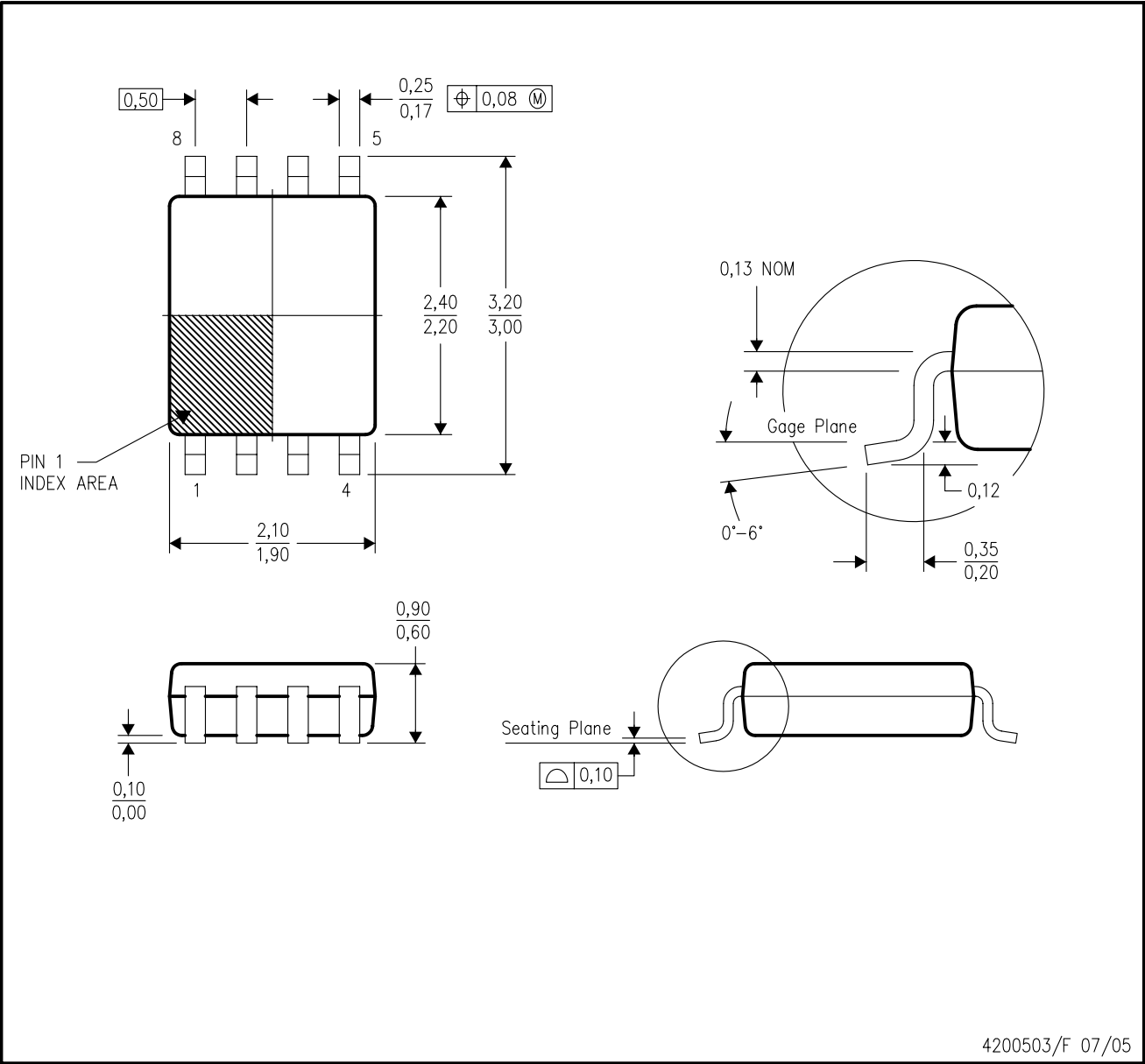

- NOTES:
- A. All linear dimensions are in millimeters.
 - B. This drawing is subject to change without notice.
 - C. Body dimensions do not include mold flash or protrusion. Mold flash and protrusion shall not exceed 0.15 per side.
 - D. Falls within JEDEC MO-187 variation CA.

DCU (S-PDSO-G8)

PLASTIC SMALL OUTLINE PACKAGE (DIE DOWN)



- NOTES:
- A. All linear dimensions are in millimeters.
 - B. This drawing is subject to change without notice.
 - C. Publication IPC-7351 is recommended for alternate designs.
 - D. Laser cutting apertures with trapezoidal walls and also rounding corners will offer better paste release. Customers should contact their board assembly site for stencil design recommendations. Refer to IPC-7525 for other stencil recommendations.
 - E. Customers should contact their board fabrication site for solder mask tolerances between and around signal pads.

YZP (R-XBGA-N8)

DIE-SIZE BALL GRID ARRAY

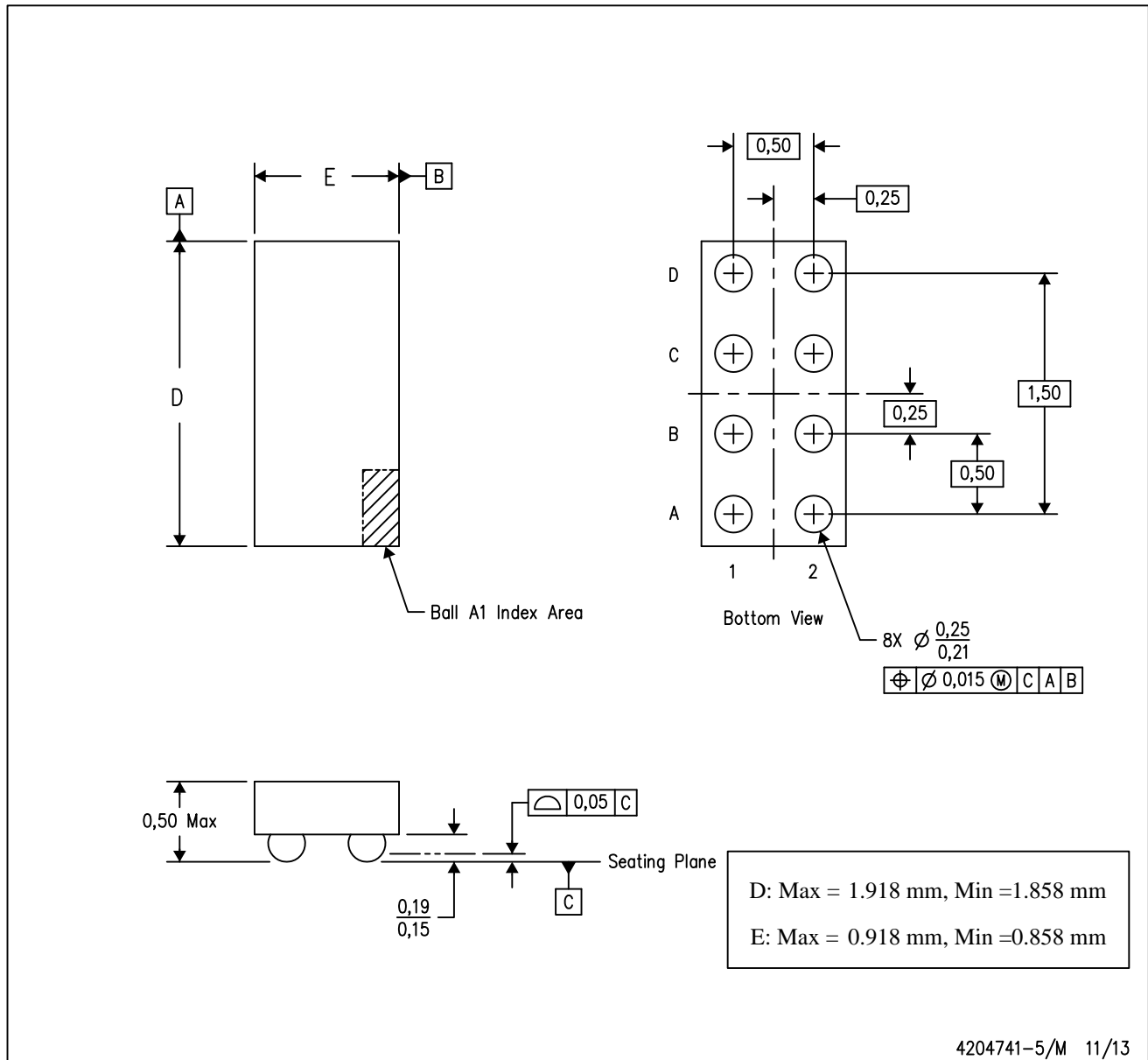

- NOTES:
- A. All linear dimensions are in millimeters. Dimensioning and tolerancing per ASME Y14.5M-1994.
 - B. This drawing is subject to change without notice.
 - C. NanoFree™ package configuration.

NanoFree is a trademark of Texas Instruments.

MECHANICAL DATA

YZT (R-XBGA-N8)

DIE-SIZE BALL GRID ARRAY

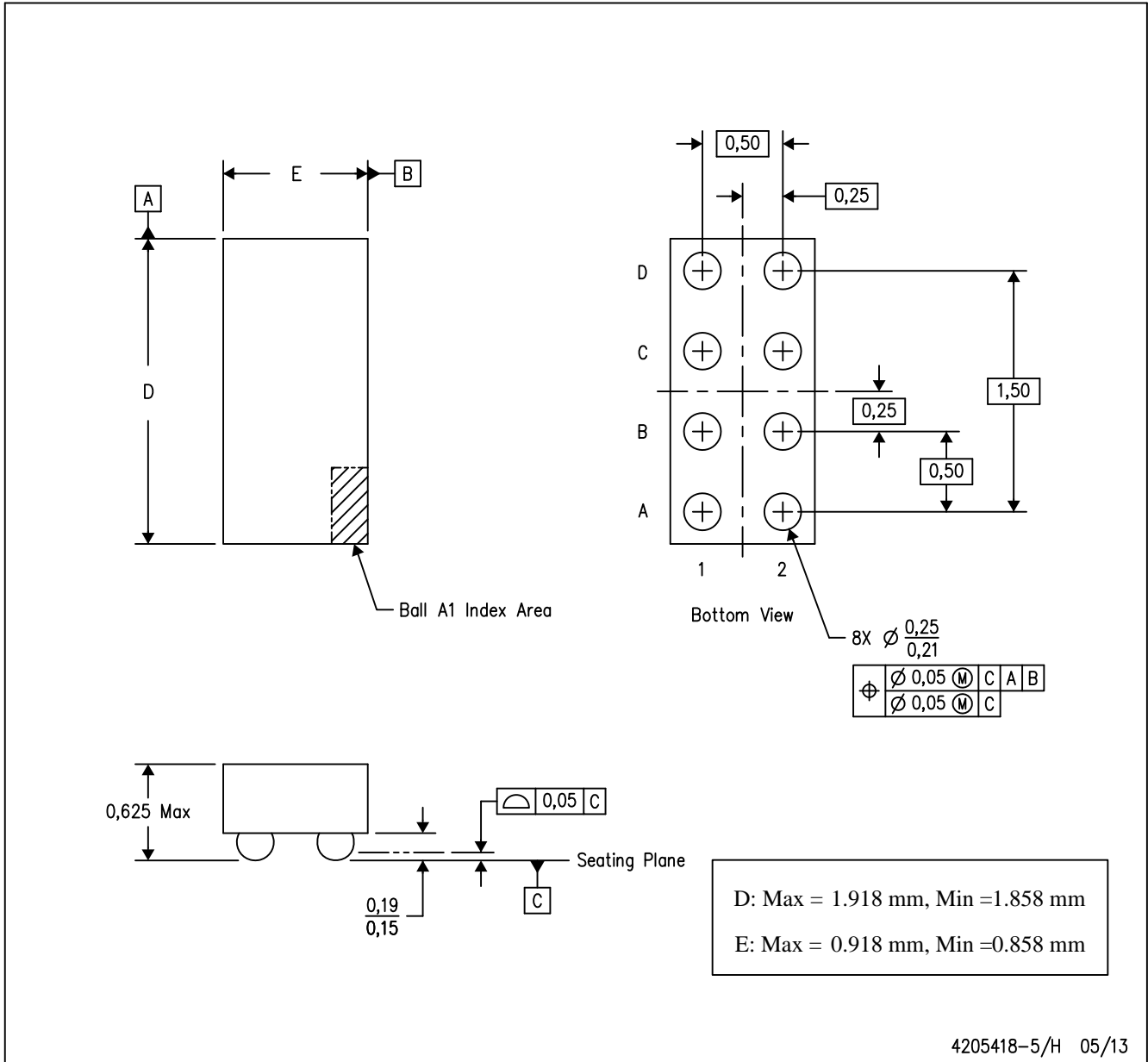

- NOTES:
- A. All linear dimensions are in millimeters. Dimensioning and tolerancing per ASME Y14.5M-1994.
 - B. This drawing is subject to change without notice.
 - C. NanoFree™ package configuration.

NanoFree is a trademark of Texas Instruments.

IMPORTANT NOTICE

Texas Instruments Incorporated and its subsidiaries (TI) reserve the right to make corrections, enhancements, improvements and other changes to its semiconductor products and services per JESD46, latest issue, and to discontinue any product or service per JESD48, latest issue. Buyers should obtain the latest relevant information before placing orders and should verify that such information is current and complete. All semiconductor products (also referred to herein as "components") are sold subject to TI's terms and conditions of sale supplied at the time of order acknowledgment.

TI warrants performance of its components to the specifications applicable at the time of sale, in accordance with the warranty in TI's terms and conditions of sale of semiconductor products. Testing and other quality control techniques are used to the extent TI deems necessary to support this warranty. Except where mandated by applicable law, testing of all parameters of each component is not necessarily performed.

TI assumes no liability for applications assistance or the design of Buyers' products. Buyers are responsible for their products and applications using TI components. To minimize the risks associated with Buyers' products and applications, Buyers should provide adequate design and operating safeguards.

TI does not warrant or represent that any license, either express or implied, is granted under any patent right, copyright, mask work right, or other intellectual property right relating to any combination, machine, or process in which TI components or services are used. Information published by TI regarding third-party products or services does not constitute a license to use such products or services or a warranty or endorsement thereof. Use of such information may require a license from a third party under the patents or other intellectual property of the third party, or a license from TI under the patents or other intellectual property of TI.

Reproduction of significant portions of TI information in TI data books or data sheets is permissible only if reproduction is without alteration and is accompanied by all associated warranties, conditions, limitations, and notices. TI is not responsible or liable for such altered documentation. Information of third parties may be subject to additional restrictions.

Resale of TI components or services with statements different from or beyond the parameters stated by TI for that component or service voids all express and any implied warranties for the associated TI component or service and is an unfair and deceptive business practice. TI is not responsible or liable for any such statements.

Buyer acknowledges and agrees that it is solely responsible for compliance with all legal, regulatory and safety-related requirements concerning its products, and any use of TI components in its applications, notwithstanding any applications-related information or support that may be provided by TI. Buyer represents and agrees that it has all the necessary expertise to create and implement safeguards which anticipate dangerous consequences of failures, monitor failures and their consequences, lessen the likelihood of failures that might cause harm and take appropriate remedial actions. Buyer will fully indemnify TI and its representatives against any damages arising out of the use of any TI components in safety-critical applications.

In some cases, TI components may be promoted specifically to facilitate safety-related applications. With such components, TI's goal is to help enable customers to design and create their own end-product solutions that meet applicable functional safety standards and requirements. Nonetheless, such components are subject to these terms.

No TI components are authorized for use in FDA Class III (or similar life-critical medical equipment) unless authorized officers of the parties have executed a special agreement specifically governing such use.

Only those TI components which TI has specifically designated as military grade or "enhanced plastic" are designed and intended for use in military/aerospace applications or environments. Buyer acknowledges and agrees that any military or aerospace use of TI components which have **not** been so designated is solely at the Buyer's risk, and that Buyer is solely responsible for compliance with all legal and regulatory requirements in connection with such use.

TI has specifically designated certain components as meeting ISO/TS16949 requirements, mainly for automotive use. In any case of use of non-designated products, TI will not be responsible for any failure to meet ISO/TS16949.

Products

Audio	www.ti.com/audio
Amplifiers	amplifier.ti.com
Data Converters	dataconverter.ti.com
DLP® Products	www.dlp.com
DSP	dsp.ti.com
Clocks and Timers	www.ti.com/clocks
Interface	interface.ti.com
Logic	logic.ti.com
Power Mgmt	power.ti.com
Microcontrollers	microcontroller.ti.com
RFID	www.ti-rfid.com
OMAP Applications Processors	www.ti.com/omap
Wireless Connectivity	www.ti.com/wirelessconnectivity

Applications

Automotive and Transportation	www.ti.com/automotive
Communications and Telecom	www.ti.com/communications
Computers and Peripherals	www.ti.com/computers
Consumer Electronics	www.ti.com/consumer-apps
Energy and Lighting	www.ti.com/energy
Industrial	www.ti.com/industrial
Medical	www.ti.com/medical
Security	www.ti.com/security
Space, Avionics and Defense	www.ti.com/space-avionics-defense
Video and Imaging	www.ti.com/video

TI E2E Community

e2e.ti.com