

Precision dual operational amplifier

Features

- Low input offset voltage: 500 μ V max.
- Low power consumption
- Short-circuit protection
- Low distortion, low noise
- High gain-bandwidth product: 3 MHz
- High channel separation
- ESD protection 2 kV
- Macromodel included in this specification

Description

The TS512 is a high performance dual operational amplifier with frequency and phase compensation built into the chip. The internal phase compensation allows stable operation in voltage follower in spite of its high gain-bandwidth product.

The circuit presents very stable electrical characteristics over the entire supply voltage range, and is particularly intended for professional and telecom applications (such as active filtering).

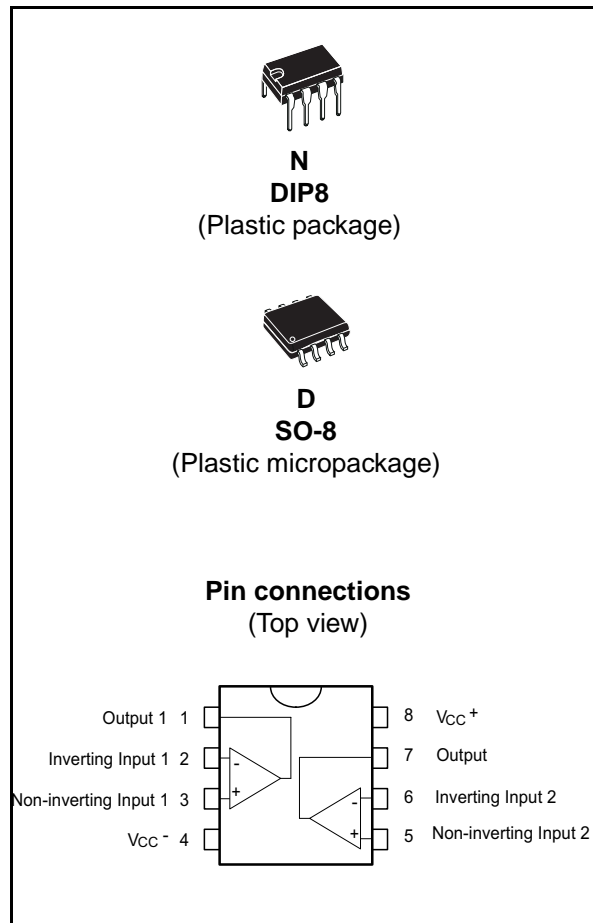

1 Absolute maximum ratings and operating conditions

Table 1. Absolute maximum ratings

Symbol	Parameter	Value	Unit
V_{CC}	Supply voltage	± 18	V
V_{in}	Input voltage	$\pm V_{CC}$	
V_{id}	Differential input voltage	$\pm(V_{CC} - 1)$	
R_{thja}	Thermal resistance junction to ambient ⁽¹⁾		$^{\circ}C/W$
	DIP8 SO-8	85 125	
R_{thjc}	Thermal resistance junction to case ⁽¹⁾		$^{\circ}C/W$
	DIP8 SO-8	41 40	
T_j	Junction temperature	+ 150	$^{\circ}C$
T_{stg}	Storage temperature range	-65 to +150	$^{\circ}C$
ESD	HBM: human body model ⁽²⁾	2	kV
	MM: machine model ⁽³⁾	200	V
	CDM: charged device model ⁽⁴⁾	1.5	kV

- Short-circuits can cause excessive heating and destructive dissipation. R_{th} are typical values.
- Human body model: A 100 pF capacitor is charged to the specified voltage, then discharged through a 1.5 k Ω resistor between two pins of the device. This is done for all couples of connected pin combinations while the other pins are floating.
- Machine model: A 200 pF capacitor is charged to the specified voltage, then discharged directly between two pins of the device with no external series resistor (internal resistor < 5 Ω). This is done for all couples of connected pin combinations while the other pins are floating.
- Charged device model: all pins and the package are charged together to the specified voltage and then discharged directly to the ground through only one pin. This is done for all pins.

Table 2. Operating conditions

Symbol	Parameter	Value	Unit
V_{CC}	Supply voltage ⁽¹⁾	6 to 30V	V
V_{icm}	Common mode input voltage range	$V_{DD}+1.5$ to $V_{CC}-1.5$	V
T_{oper}	Operating free air temperature range	-40 to +125	$^{\circ}C$

- Value with respect to V_{DD} pin.

2 Schematic diagram

Figure 1. Schematic diagram (1/2 TS512)

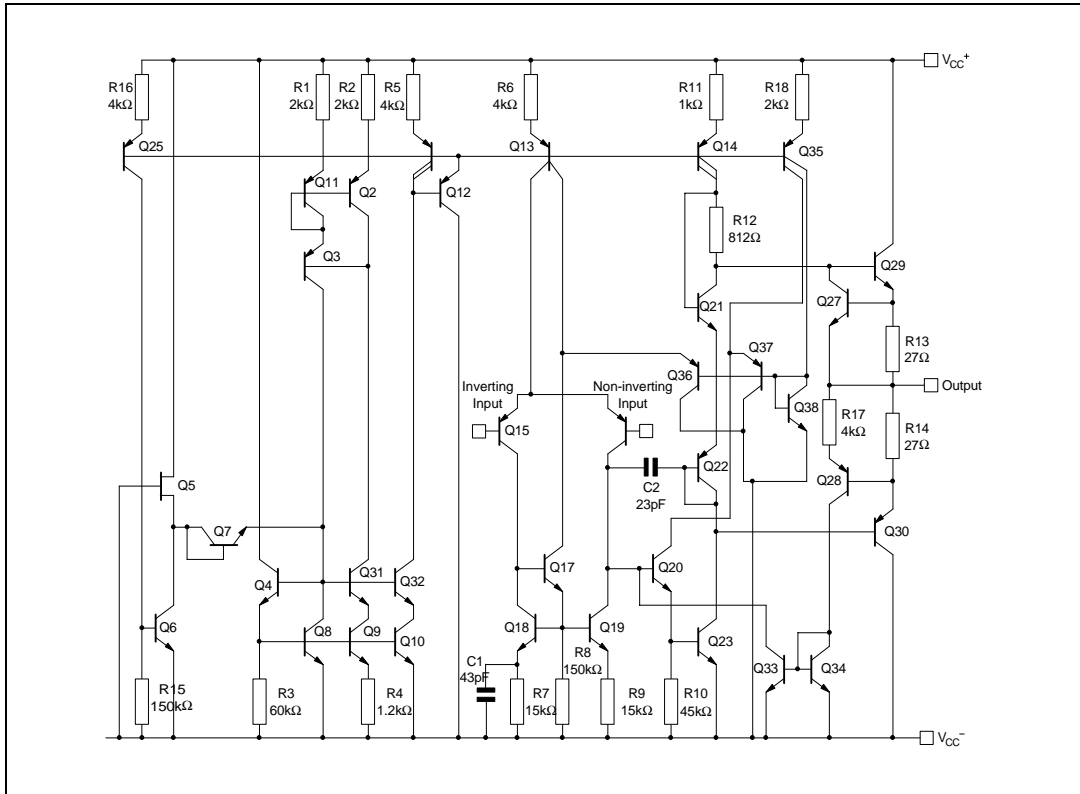

3 Electrical characteristics

Table 3. $V_{CC} = \pm 15V$, $T_{amb} = 25^{\circ}C$ (unless otherwise specified)

Symbol	Parameter	Min.	Typ.	Max.	Unit
I_{CC}	Supply current (per operator) $T_{min} \leq T_{amb} \leq T_{max}$		0.5	0.6 0.75	mA
I_{ib}	Input bias current $T_{min} \leq T_{amb} \leq T_{max}$		50	150 300	nA
R_{in}	Input resistance, $f = 1kHz$		1		M Ω
V_{io}	Input offset voltage TS512 TS512A $T_{min} \leq T_{amb} \leq T_{max}$ TS512 TS512A		0.5	2.5 0.5 3.5 1.5	mV
ΔV_{io}	Input offset voltage drift $T_{min} \leq T_{amb} \leq T_{max}$		2		$\mu V/^{\circ}C$
I_{io}	Input offset current $T_{min} \leq T_{amb} \leq T_{max}$		5	20 40	nA
ΔI_{io}	Input offset current drift $T_{min} \leq T_{amb} \leq T_{max}$		0.08		$\frac{nA}{^{\circ}C}$
I_{os}	Output short-circuit current		23		mA
A_{vd}	Large signal voltage gain $R_L = 2k\Omega$, $V_{CC} = \pm 15V$, $T_{min} \leq T_{amb} \leq T_{max}$ $V_{CC} = \pm 4V$	90	100 95		dB
GBP	Gain-bandwidth product, $f = 100kHz$	1.8	3		MHz
e_n	Equivalent input noise voltage, $f = 1kHz$ $R_s = 50\Omega$ $R_s = 1k\Omega$ $R_s = 10k\Omega$		8 10 18		$\frac{nV}{\sqrt{Hz}}$
THD	Total harmonic distortion $A_v = 20dB$, $R_L = 2k\Omega$ $V_o = 2V_{pp}$, $f = 1kHz$		0.03		%
$\pm V_{opp}$	Output voltage swing $R_L = 2k\Omega$, $V_{CC} = \pm 15V$, $T_{min} \leq T_{amb} \leq T_{max}$ $V_{CC} = \pm 4V$	± 13	± 3		V
V_{opp}	Large signal voltage swing $R_L = 10k\Omega$, $f = 10kHz$		28		V_{pp}
SR	Slew rate Unity gain, $R_L = 2k\Omega$	0.8	1.5		V/ μs
CMR	Common mode rejection ratio $V_{ic} = \pm 10V$	90			dB

Table 3. $V_{CC} = \pm 15V$, $T_{amb} = 25^{\circ}C$ (unless otherwise specified)

Symbol	Parameter	Min.	Typ.	Max.	Unit
SVR	Supply voltage rejection ratio	90			dB
V_{01}/V_{02}	Channel separation, $f = 1kHz$		120		dB

Figure 2. V_{io} distribution at $V_{CC} = \pm 15V$ and $T = 25^\circ C$

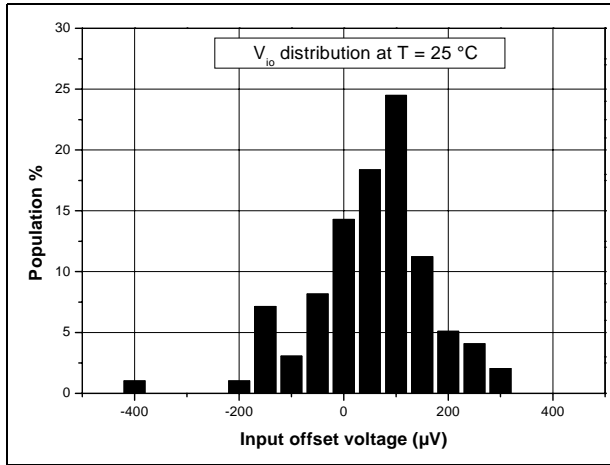

Figure 3. V_{io} distribution at $V_{CC} = \pm 15V$ and $T = 125^\circ C$

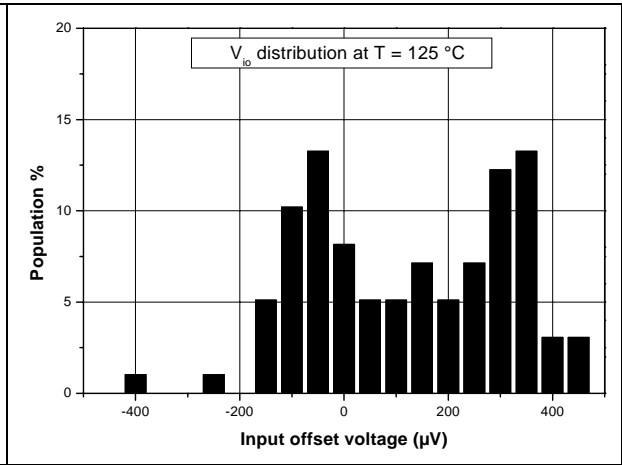

Figure 4. Input offset voltage vs. input common mode voltage at $V_{CC} = 10V$

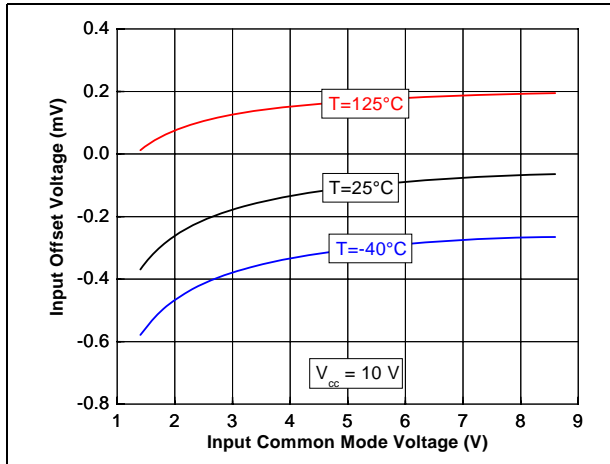

Figure 5. Input offset voltage vs. input common mode voltage at $V_{CC} = 30V$

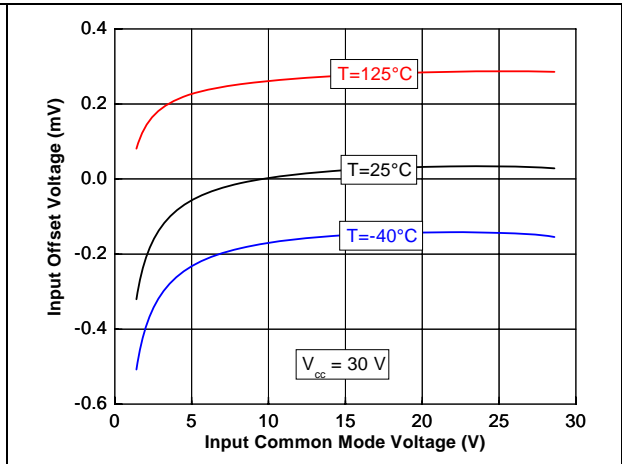

Figure 6. Supply current (per operator) vs. supply voltage at $V_{icm} = V_{CC}/2$

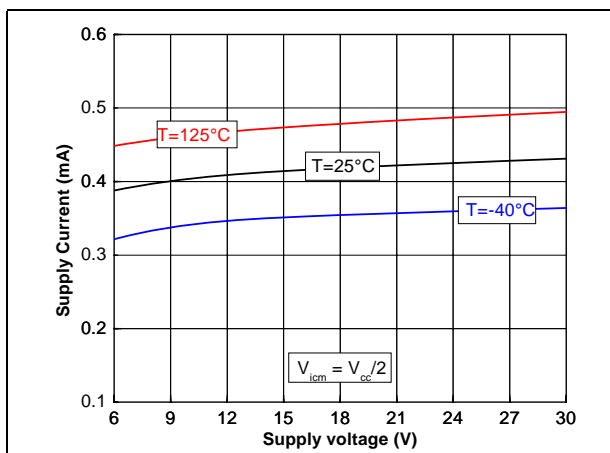

Figure 7. Supply current (per operator) vs. input common mode voltage at $V_{CC} = 6V$

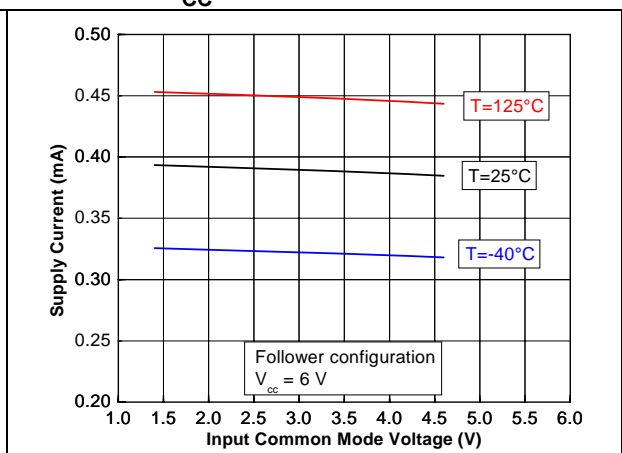

Figure 8. Supply current (per operator) vs. input common mode voltage at $V_{CC} = 10V$

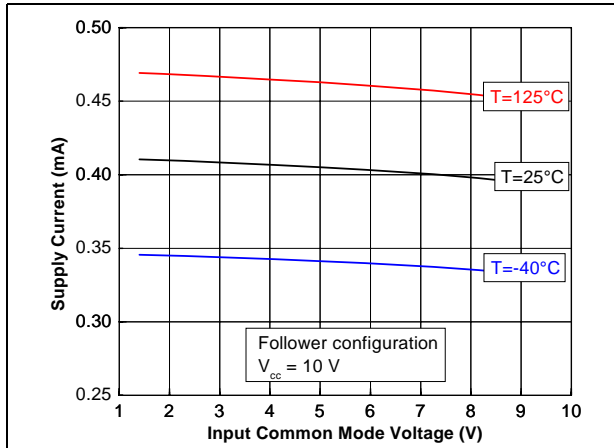

Figure 9. Supply current (per operator) vs. input common mode voltage at $V_{CC} = 30V$

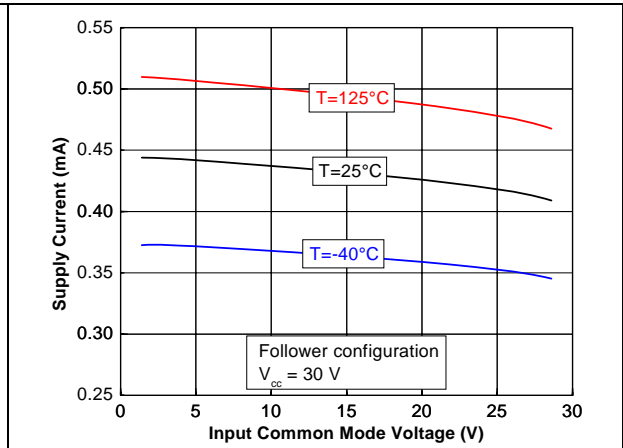

Figure 10. Output current vs. supply voltage at $V_{icm} = V_{CC}/2$

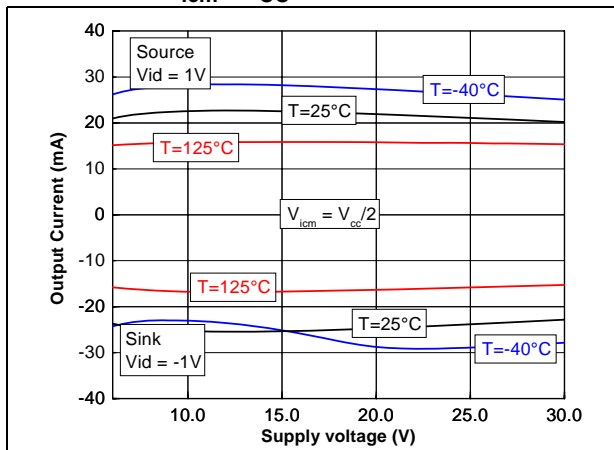

Figure 11. Output current vs. output voltage at $V_{CC} = 6V$

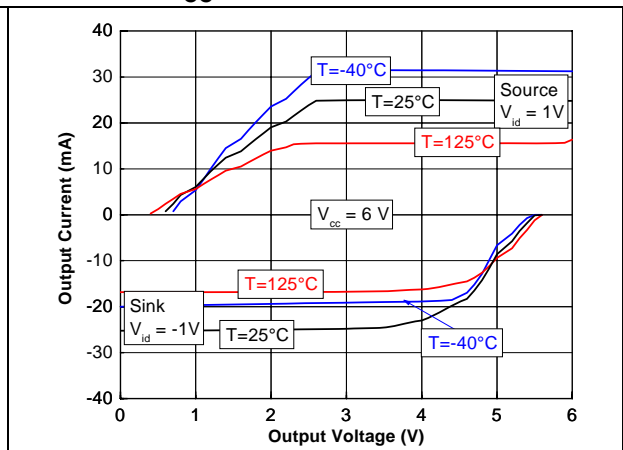

Figure 12. Output current vs. output voltage at $V_{CC} = 10V$

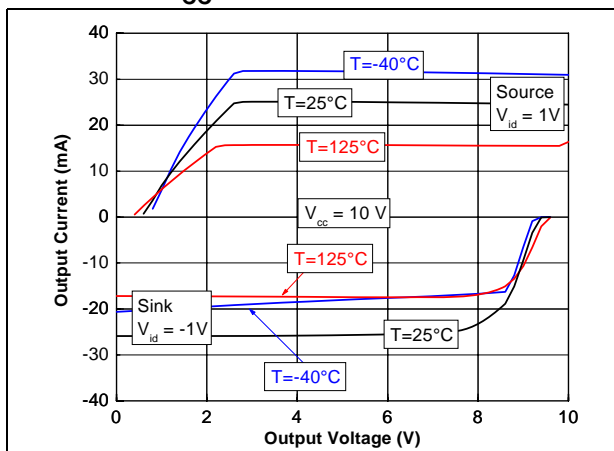

Figure 13. Output current vs. output voltage at $V_{CC} = 30V$

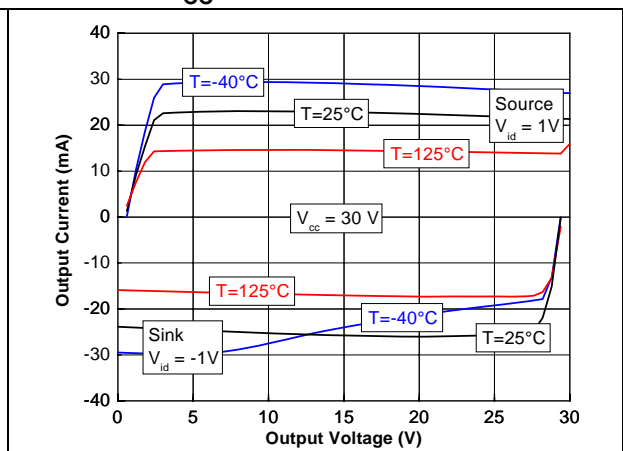

Figure 14. Voltage gain and phase for different capacitive loads at $V_{CC}= 6V$, $V_{icm}= 3V$ and $T= 25^{\circ}C$

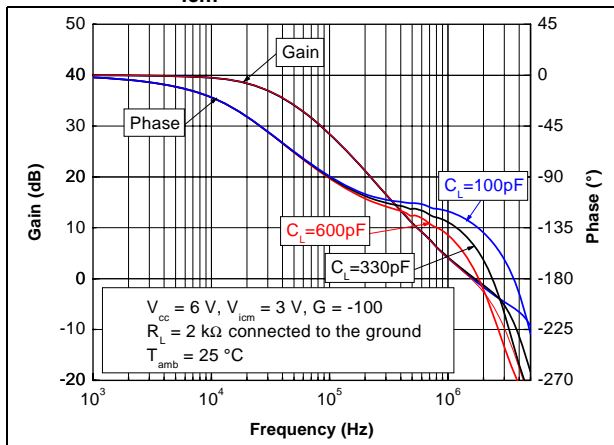

Figure 15. Voltage gain and phase for different capacitive loads at $V_{CC}= 10V$, $V_{icm}= 5V$ and $T= 25^{\circ}C$

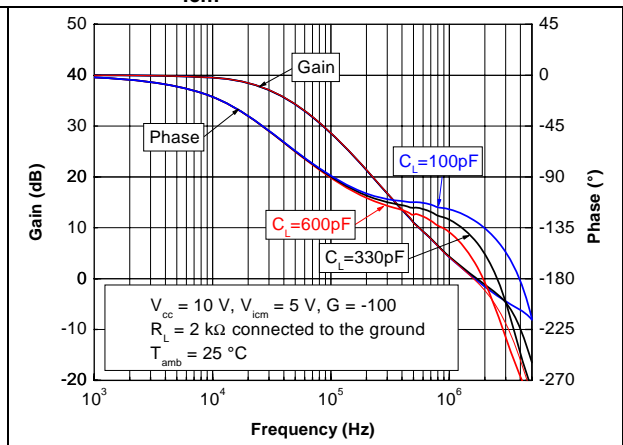

Figure 16. Voltage gain and phase for different capacitive loads at $V_{CC}= 30V$, $V_{icm}= 15V$ and $T= 25^{\circ}C$

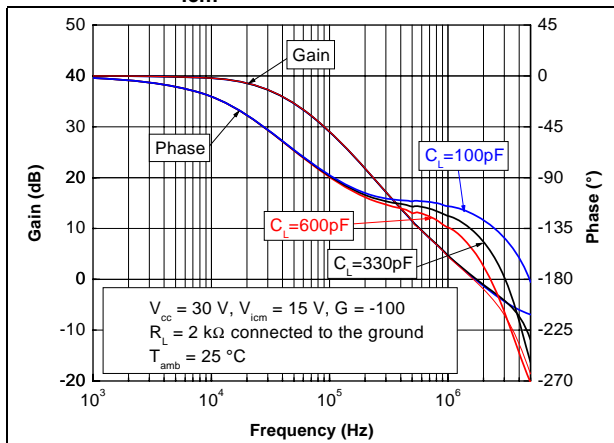

Figure 17. Frequency response for different capacitive loads at $V_{CC}= 6V$, $V_{icm}= 3V$ and $T= 25^{\circ}C$

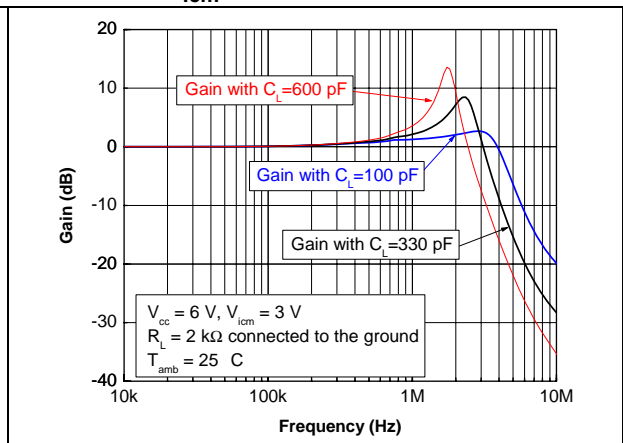

Figure 18. Frequency response for different capacitive loads at $V_{CC}= 10V$, $V_{icm}= 5V$ and $T= 25^{\circ}C$

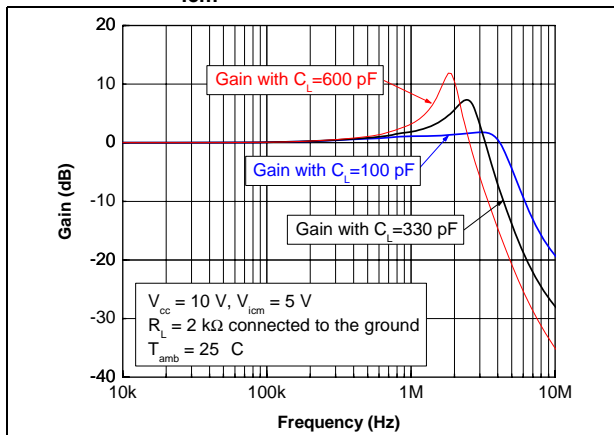

Figure 19. Frequency response for different capacitive loads at $V_{CC}= 30V$, $V_{icm}= 15V$ and $T= 25^{\circ}C$

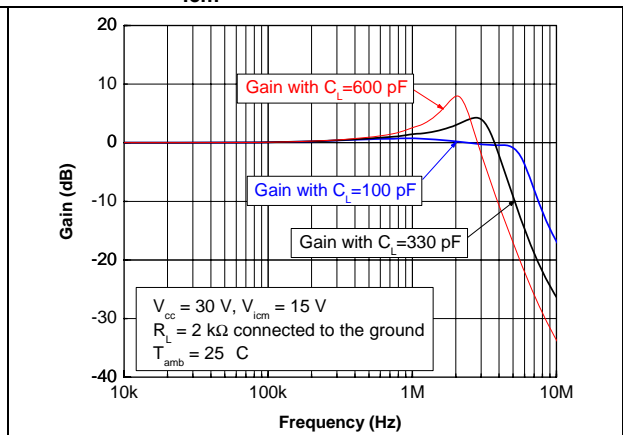

Figure 20. Phase margin vs. output current, at $V_{CC}= 6V$, $V_{icm}= 3V$ and $T= 25^{\circ}C$

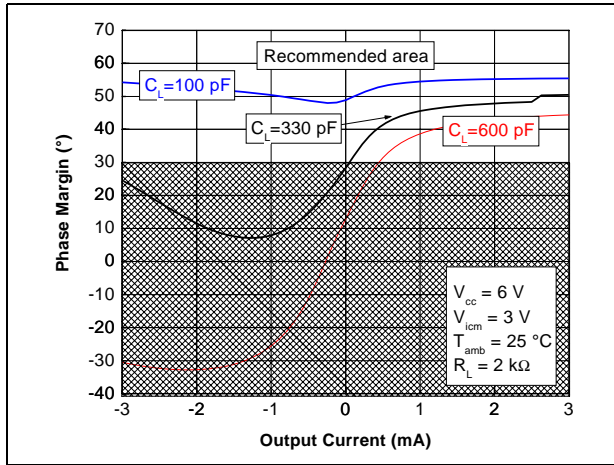

Figure 21. Phase margin vs. output current, at $V_{CC}= 10V$, $V_{icm}= 5V$ and $T= 25^{\circ}C$

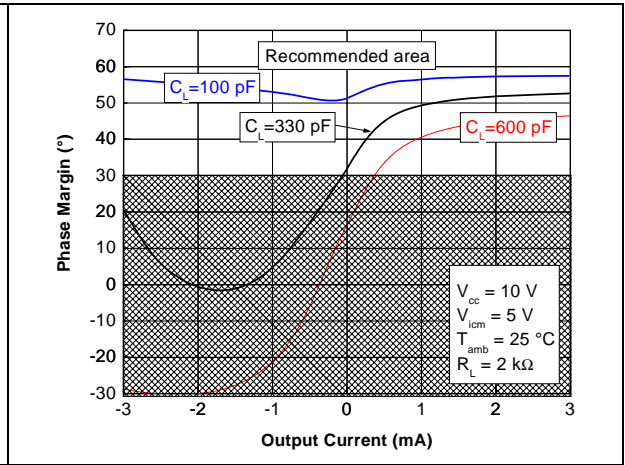
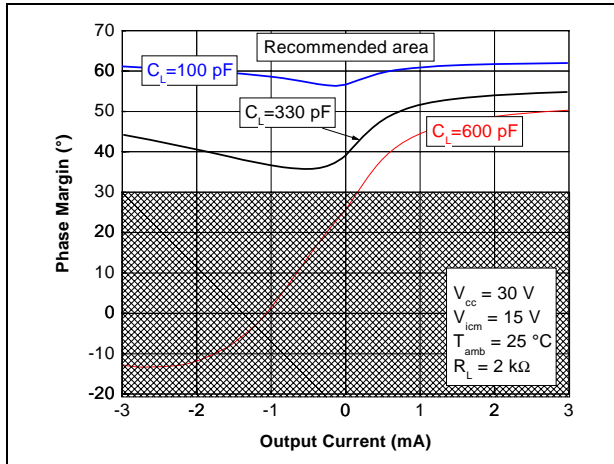

Figure 22. Phase margin vs. output current, at $V_{CC}= 30V$, $V_{icm}= 15V$ and $T= 25^{\circ}C$



4 Macromodels

4.1 Important note concerning this macromodel

Please consider the following remarks before using this macromodel.

- All models are a trade-off between accuracy and complexity (i.e. simulation time).
- Macromodels are not a substitute to breadboarding; rather, they confirm the validity of a design approach and help to select surrounding component values.
- A macromodel emulates the **nominal** performance of a **typical** device within **specified operating conditions** (temperature, supply voltage, for example). Thus the macromodel is often not as exhaustive as the datasheet, its purpose is to illustrate the main parameters of the product.

Data derived from macromodels used outside of the specified conditions (V_{CC} , temperature, for example) or even worse, outside of the device operating conditions (V_{CC} , V_{icm} , for example), is not reliable in any way.

4.2 Macromodel code

```
** Standard Linear Ics Macromodels, 1993.
** CONNECTIONS :
* 1 INVERTING INPUT
* 2 NON-INVERTING INPUT
* 3 OUTPUT
* 4 POSITIVE POWER SUPPLY
* 5 NEGATIVE POWER SUPPLY

.SUBCKT TS512 1 3 2 4 5
*****
.MODEL MDTH D IS=1E-8 KF=6.565195E-17 CJO=10F
* INPUT STAGE
CIP 2 5 1.000000E-12
CIN 1 5 1.000000E-12
EIP 10 5 2 5 1
EIN 16 5 1 5 1
RIP 10 11 2.600000E+01
RIN 15 16 2.600000E+01
RIS 11 15 1.061852E+02
DIP 11 12 MDTH 400E-12
DIN 15 14 MDTH 400E-12
VOFP 12 13 DC 0
VOFN 13 14 DC 0
IPOL 13 5 1.000000E-05
CPS 11 15 12.47E-10
DINN 17 13 MDTH 400E-12
VIN 17 5 1.500000E+00
DINR 15 18 MDTH 400E-12
VIP 4 18 1.500000E+00
FCP 4 5 VOFP 3.400000E+01
FCN 5 4 VOFN 3.400000E+01
```

```

FIBP 2 5 VOFN 1.000000E-02
FIBN 5 1 VOFN 1.000000E-02
* AMPLIFYING STAGE
FIP 5 19 VOFN 9.000000E+02
FIN 5 19 VOFN 9.000000E+02
RG1 19 5 1.727221E+06
RG2 19 4 1.727221E+06
CC 19 5 6.000000E-09
DOPM 19 22 MDTH 400E-12
DONM 21 19 MDTH 400E-12
HOPM 22 28 VOUT 6.521739E+03
VIPM 28 4 1.500000E+02
HONM 21 27 VOUT 6.521739E+03
VINM 5 27 1.500000E+02
GCOMP 5 4 4 5 6.485084E-04
RPM1 5 80 1E+06
RPM2 4 80 1E+06
GAVPH 5 82 19 80 2.59E-03
RAVPHGH 82 4 771
RAVPHGB 82 5 771
RAVPHDH 82 83 1000
RAVPHDB 82 84 1000
CAVPHH 4 83 0.331E-09
CAVPHB 5 84 0.331E-09
EOUT 26 23 82 5 1
VOUT 23 5 0
ROUT 26 3 6.498455E+01
COUT 3 5 1.000000E-12
DOP 19 25 MDTH 400E-12
VOP 4 25 1.742230E+00
DON 24 19 MDTH 400E-12
VON 24 5 1.742230E+00
.ENDS

```

Table 4. $V_{CC} = \pm 15V$, $T_{amb} = 25^{\circ}C$ (unless otherwise specified)

Symbol	Conditions	Value	Unit
V_{io}		0	mV
A_{vd}	$R_L = 2k\Omega$	100	V/mV
I_{CC}	No load, per operator	350	μA
V_{icm}		-13.4 to 14	V
V_{OH}	$R_L = 2k\Omega$	+14	V
V_{OL}	$R_L = 2k\Omega$	-14	V
I_{sink}	$V_o = 0V$	27.5	mA
I_{source}	$V_o = 0V$	27.5	mA
GBP	$R_L = 2k\Omega$, $C_L = 100pF$	2.5	MHz
SR	$R_L = 2k\Omega$	1.4	V/ μs
ϕ_m	$R_L = 2k\Omega$, $C_L = 100pF$	55	Degrees

5 Package information

In order to meet environmental requirements, ST offers these devices in ECOPACK® packages. These packages have a lead-free second level interconnect. The category of second level interconnect is marked on the package and on the inner box label, in compliance with JEDEC Standard JESD97. The maximum ratings related to soldering conditions are also marked on the inner box label. ECOPACK is an ST trademark. ECOPACK specifications are available at: www.st.com.

Figure 23. DIP8 package mechanical drawing

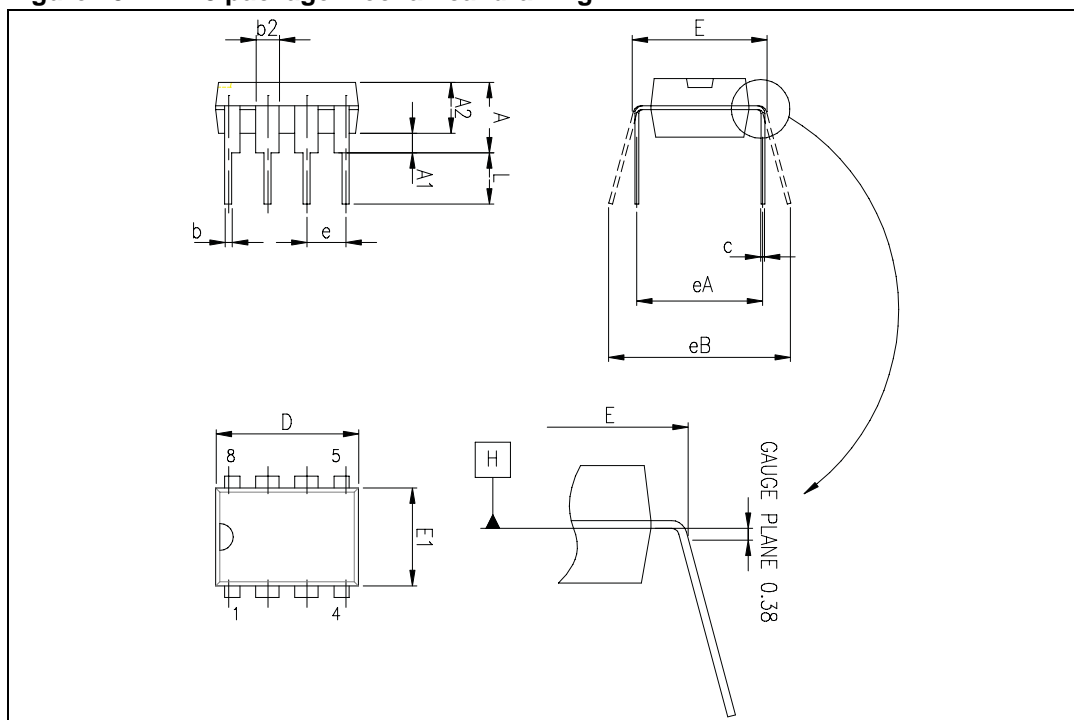

Table 5. DIP8 package mechanical data

Ref.	Dimensions					
	Millimeters			Inches		
	Min.	Typ.	Max.	Min.	Typ.	Max.
A			5.33			0.210
A1	0.38			0.015		
A2	2.92	3.30	4.95	0.115	0.130	0.195
b	0.36	0.46	0.56	0.014	0.018	0.022
b2	1.14	1.52	1.78	0.045	0.060	0.070
c	0.20	0.25	0.36	0.008	0.010	0.014
D	9.02	9.27	10.16	0.355	0.365	0.400
E	7.62	7.87	8.26	0.300	0.310	0.325
E1	6.10	6.35	7.11	0.240	0.250	0.280
e		2.54			0.100	
eA		7.62			0.300	
eB			10.92			0.430
L	2.92	3.30	3.81	0.115	0.130	0.150

Figure 24. SO-8 package mechanical drawing

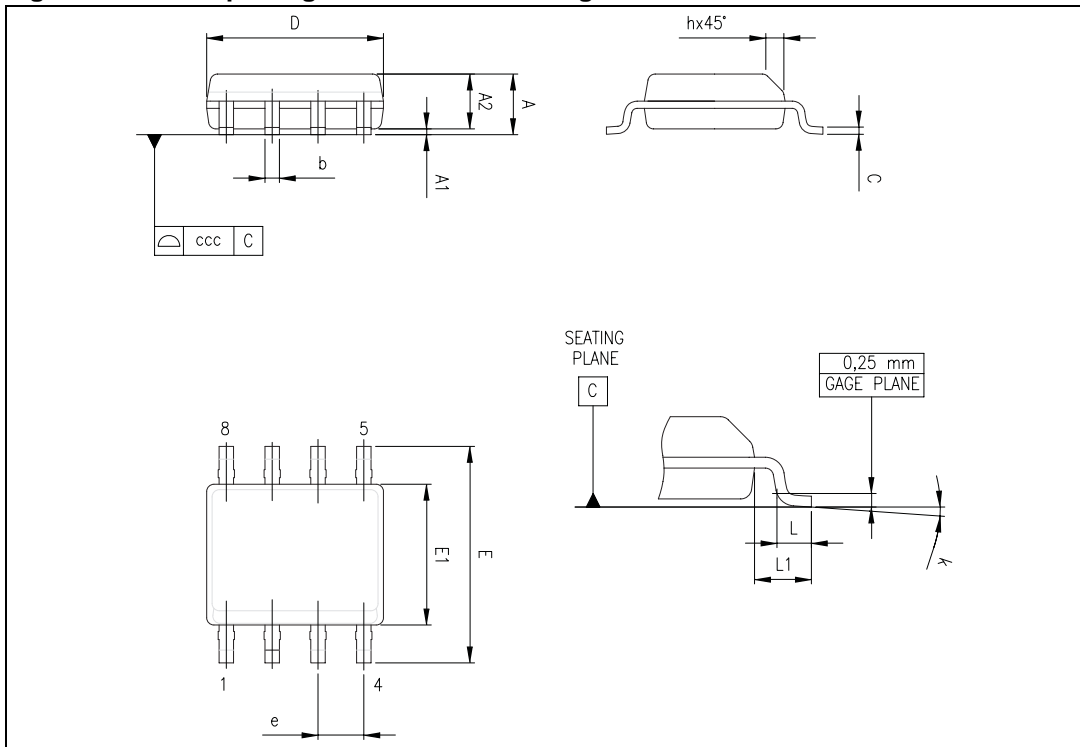

Table 6. SO-8 package mechanical data

Ref.	Dimensions					
	Millimeters			Inches		
	Min.	Typ.	Max.	Min.	Typ.	Max.
A			1.75			0.069
A1	0.10		0.25	0.004		0.010
A2	1.25			0.049		
b	0.28		0.48	0.011		0.019
c	0.17		0.23	0.007		0.010
D	4.80	4.90	5.00	0.189	0.193	0.197
E	5.80	6.00	6.20	0.228	0.236	0.244
E1	3.80	3.90	4.00	0.150	0.154	0.157
e		1.27			0.050	
h	0.25		0.50	0.010		0.020
L	0.40		1.27	0.016		0.050
k	1°		8°	1°		8°
ccc			0.10			0.004

6 Ordering information

Table 7. Order codes

Order code	Temperature range	Package	Packaging	Marking
TS512IN	-40°C, + 125°C	DIP8	Tube	512IN
TS512AIN				512AIN
TS512ID TS512IDT		SO-8	Tube or Tape & reel	512I
TS512AID-DT				512AI
TS512IYD ⁽¹⁾ TS512IYDT ⁽¹⁾		SO-8 (Automotive grade)	Tube or Tape & reel	512IY
TS512AIYD ⁽¹⁾ TS512AIYDT ⁽¹⁾				512AIY

1. Qualification and characterization according to AEC Q100 and Q003 or equivalent, advanced screening according to AEC Q001 & Q 002 or equivalent are on-going.

7 Revision history

Table 8. Document revision history

Date	Revision	Changes
21-Nov-2001	1	Initial release.
23-Jun-2005	2	PPAP references inserted in the datasheet, see Table 7: Order codes .
5-May-2008	3	AC and DC performance characteristics curves added for $V_{CC}= 6V$, $V_{CC}= 10V$ and $V_{CC}= 30V$. Modified I_{CC} typ, added parameters over temperature range in electrical characteristics table. Corrected macromodel information.

Please Read Carefully:

Information in this document is provided solely in connection with ST products. STMicroelectronics NV and its subsidiaries ("ST") reserve the right to make changes, corrections, modifications or improvements, to this document, and the products and services described herein at any time, without notice.

All ST products are sold pursuant to ST's terms and conditions of sale.

Purchasers are solely responsible for the choice, selection and use of the ST products and services described herein, and ST assumes no liability whatsoever relating to the choice, selection or use of the ST products and services described herein.

No license, express or implied, by estoppel or otherwise, to any intellectual property rights is granted under this document. If any part of this document refers to any third party products or services it shall not be deemed a license grant by ST for the use of such third party products or services, or any intellectual property contained therein or considered as a warranty covering the use in any manner whatsoever of such third party products or services or any intellectual property contained therein.

UNLESS OTHERWISE SET FORTH IN ST'S TERMS AND CONDITIONS OF SALE ST DISCLAIMS ANY EXPRESS OR IMPLIED WARRANTY WITH RESPECT TO THE USE AND/OR SALE OF ST PRODUCTS INCLUDING WITHOUT LIMITATION IMPLIED WARRANTIES OF MERCHANTABILITY, FITNESS FOR A PARTICULAR PURPOSE (AND THEIR EQUIVALENTS UNDER THE LAWS OF ANY JURISDICTION), OR INFRINGEMENT OF ANY PATENT, COPYRIGHT OR OTHER INTELLECTUAL PROPERTY RIGHT.

UNLESS EXPRESSLY APPROVED IN WRITING BY AN AUTHORIZED ST REPRESENTATIVE, ST PRODUCTS ARE NOT RECOMMENDED, AUTHORIZED OR WARRANTED FOR USE IN MILITARY, AIR CRAFT, SPACE, LIFE SAVING, OR LIFE SUSTAINING APPLICATIONS, NOR IN PRODUCTS OR SYSTEMS WHERE FAILURE OR MALFUNCTION MAY RESULT IN PERSONAL INJURY, DEATH, OR SEVERE PROPERTY OR ENVIRONMENTAL DAMAGE. ST PRODUCTS WHICH ARE NOT SPECIFIED AS "AUTOMOTIVE GRADE" MAY ONLY BE USED IN AUTOMOTIVE APPLICATIONS AT USER'S OWN RISK.

Resale of ST products with provisions different from the statements and/or technical features set forth in this document shall immediately void any warranty granted by ST for the ST product or service described herein and shall not create or extend in any manner whatsoever, any liability of ST.

ST and the ST logo are trademarks or registered trademarks of ST in various countries.

Information in this document supersedes and replaces all information previously supplied.

The ST logo is a registered trademark of STMicroelectronics. All other names are the property of their respective owners.

© 2008 STMicroelectronics - All rights reserved

STMicroelectronics group of companies

Australia - Belgium - Brazil - Canada - China - Czech Republic - Finland - France - Germany - Hong Kong - India - Israel - Italy - Japan - Malaysia - Malta - Morocco - Singapore - Spain - Sweden - Switzerland - United Kingdom - United States of America

www.st.com