

## Low voltage adjustable shunt reference

### Features

- Low voltage operation: 1.24 to 6V
- 2%, 1% and 0.5% voltage precision
- Wide operating range cathode current: 60 $\mu$ A to 30mA
- Low output impedance: 0.2 $\Omega$
- Typically stable for any capacitive loads
- ESD protection:
  - Human body model: 2kV
  - Machine model: 200V
- 100ppm/ $^{\circ}$ C temperature coefficient

### Description

The TS431 is a low-voltage, three-terminal, programmable shunt voltage reference.

The output voltage can be set to any value between  $V_{ref}$  (1.24V) and 6V with two external resistors.

The TS431 is able to operate at a lower voltage (1.24V) and lower cathode current than the widely used TL431 and TL1431 shunt voltage reference.

When driving an optocoupler, the TS431 is particularly useful for regulating 3.3V switching power supplies.

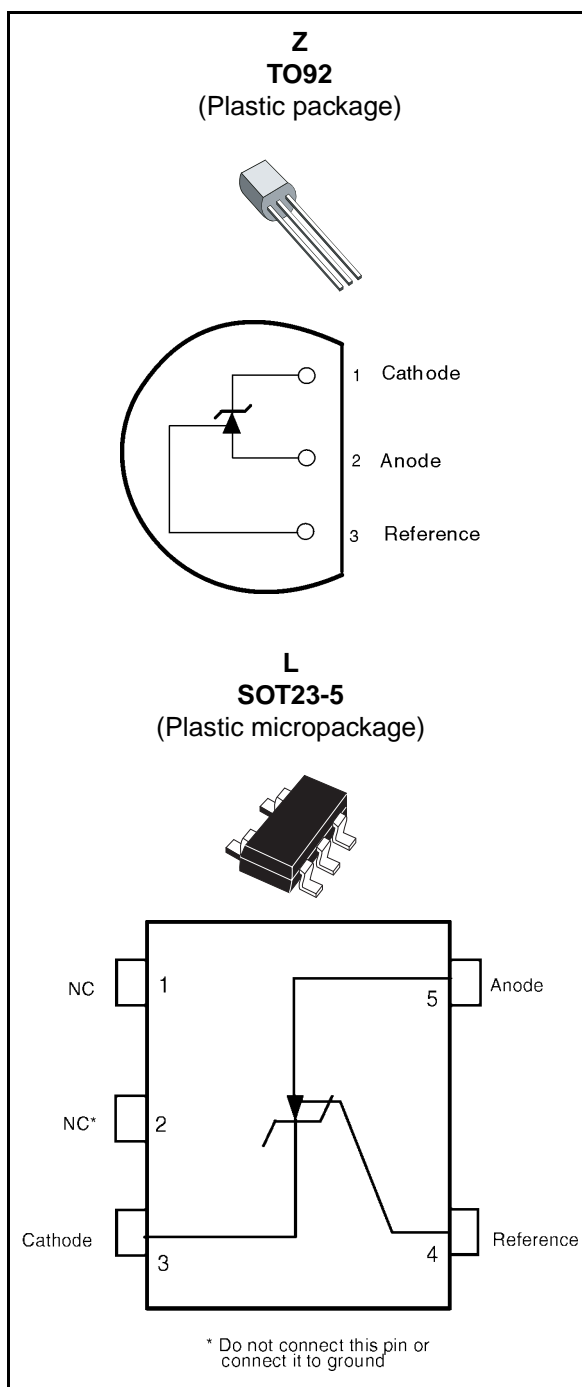

# 1 Absolute maximum ratings and operating conditions

**Table 1. Absolute maximum ratings**

Symbol	Parameter	Value	Unit
$V_{KA}$	Cathode to anode voltage	10	V
$I_k$	Continuous cathode current range	-20 to +40	mA
$I_{ref}$	Reference input current range	-0.05 to +3	mA
$P_d$	Power dissipation <sup>(1)</sup> TO92 package SOT23-5 package	625 500	mW
$T_{stg}$	Storage temperature range	-65 to +150	°C

1.  $T_{junction}=150^{\circ}C$ ,  $T_{amb}=25^{\circ}C$  with  
 $R_{THj-a}=200^{\circ}C/W$  for TO92 package and  
 $R_{THj-a}=250^{\circ}C/W$  for SOT23-5L package

**Table 2. Operating conditions**

Symbol	Parameter	Value	Unit
$V_{KA}$	Cathode to anode voltage	1.24 to 6	V
$I_k$	Cathode current	0.06 to 30	mA
$T_{oper}$	Operating free air temperature range	-40 to +125	°C

## 2 Electrical characteristics

**Table 3.**  $T_{amb} = 25^{\circ}\text{C}$  (unless otherwise specified)

Symbol	Parameter	Test conditions	Min.	Typ.	Max.	Unit
$V_{ref}$	Output voltage $V_{KA} = V_{ref}$ @ $I_k = 100\mu\text{A}$	TS431 TS431A TS431B	1.215 1.228 1.234	1.240	1.265 1.252 1.246	V
$\Delta V_{ref}$	Output voltage change <sup>(1) (2)</sup> $I_k = 100\mu\text{A}, V_{KA} = V_{ref}$	$0 < T_{amb} < +70^{\circ}\text{C}$ $-40 < T_{amb} < +85^{\circ}\text{C}$ $-40 < T_{amb} < +105^{\circ}\text{C}$ $-40 < T_{amb} < +125^{\circ}\text{C}$			9 16 18 21	mV
$\frac{ \Delta V_{ref} }{\Delta V_{ka}}$	Ratio of change in reference input voltage to change in cathode to anode voltage	$I_k = 10\text{mA}$ $V_{KA} = 6\text{V to } V_{ref}$		1.8	2.7	mV/V
$I_{ref}$	Reference input current	$I_k = 10\text{mA}$		70	160	nA
$\Delta I_{ref}$	Reference input current deviation over temperature range	$I_k=10\text{mA}, R_1=10\text{k}\Omega, R_2=\infty$ $-40 < T_{amb} < +85^{\circ}\text{C}$ $-40 < T_{amb} < +125^{\circ}\text{C}$		70 90	160 240	nA
$I_{min}$	Minimum cathode current for regulation	$V_{KA} = V_{ref}$		40	60	$\mu\text{A}$
$I_{off}$	Off-state cathode current	$V_{KA} = 6\text{V}, V_{ref} = 0$		0.001	0.1	$\mu\text{A}$
$R_{KA}$	Static impedance	$V_{KA} = V_{ref}, I_k = 0.1 \text{ to } 15\text{mA}$		0.2	0.4	$\Omega$

- Limits are 100% production tested at 25°C. Behavior at the temperature range limits is guaranteed through correlation and by design.
- See definition below.

### Definition of output voltage change over temperature range

$\Delta V_{ref}$  is defined as the difference between the maximum and minimum values obtained over the full temperature range.

$$\Delta V_{ref} = V_{ref \text{ max}} - V_{ref \text{ min}}$$

**Figure 1.** Output voltage change over temperature range

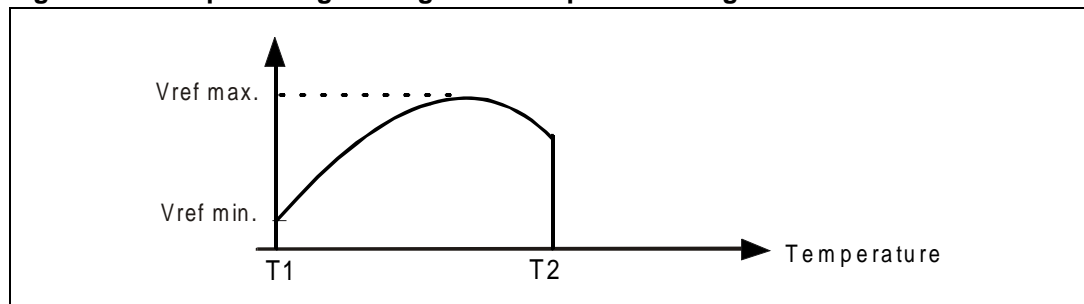

Figure 2. Reference voltage vs. temperature

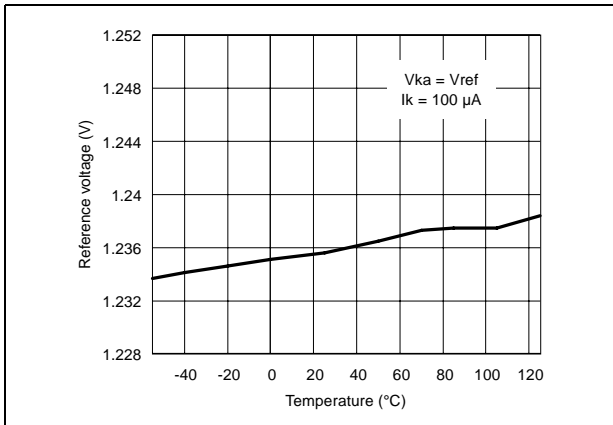

Figure 3. Test circuit for  $V_{KA} = V_{ref}$

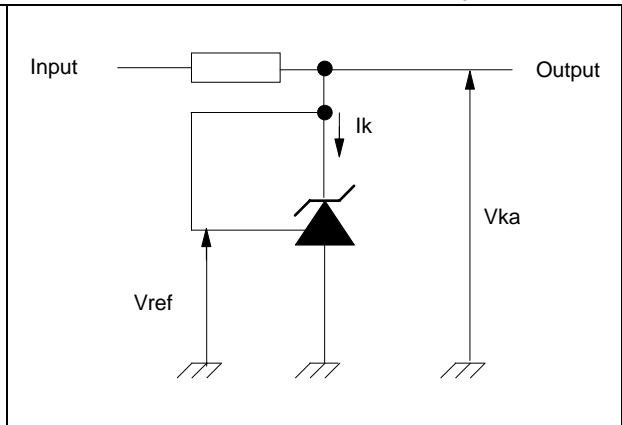

Figure 4. Cathode voltage vs. cathode current

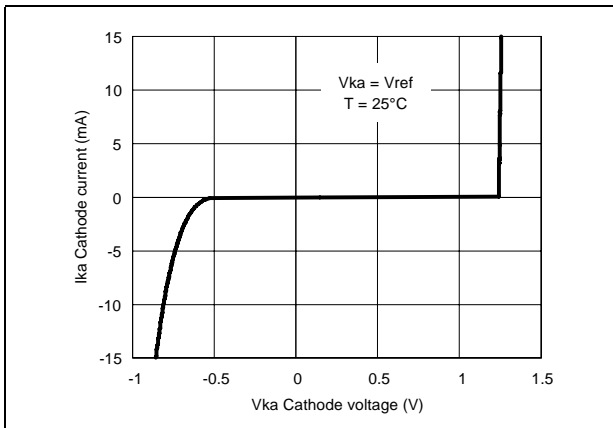

Figure 5. Cathode voltage vs. cathode current

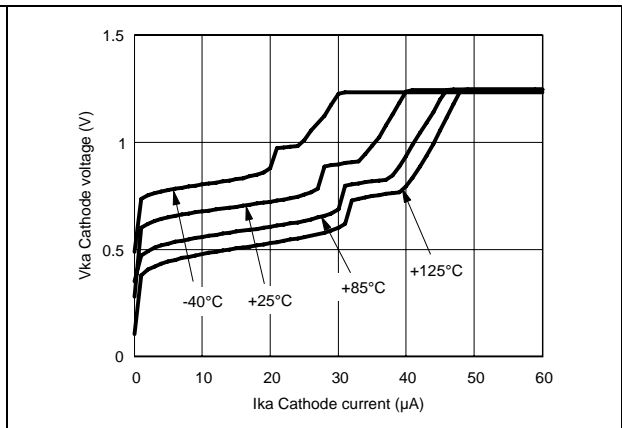

Figure 6. Reference input current vs. temperature

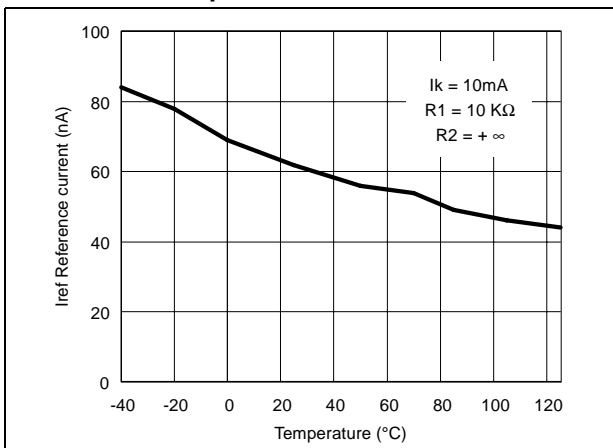

Figure 7. Static impedance vs. temperature

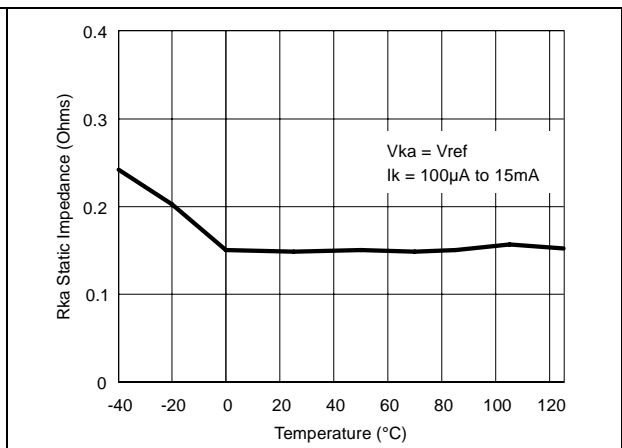

Figure 8. Off-state current vs. temperature

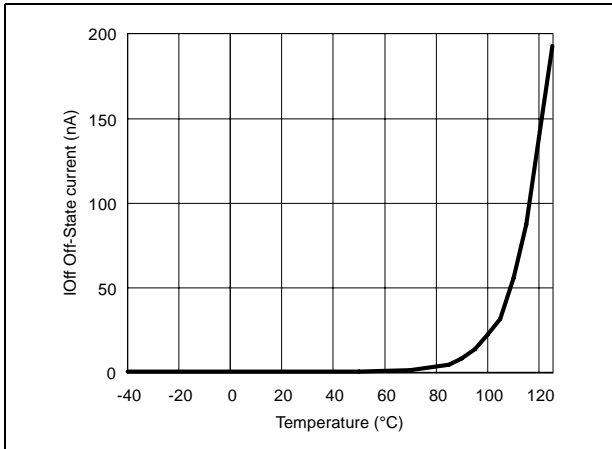

Figure 9. Test circuit for off-state current measurement

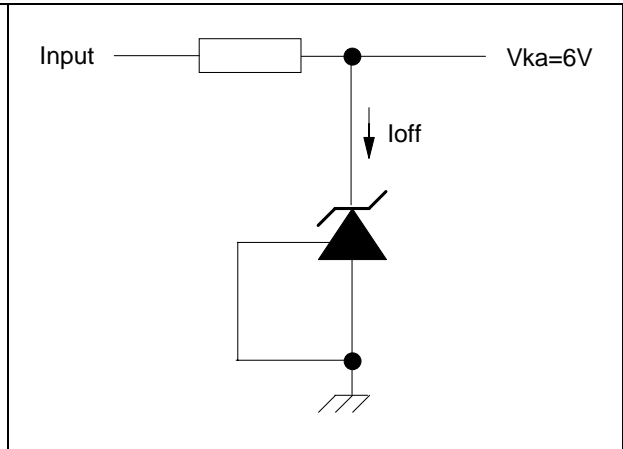

Figure 10. Ratio of change in reference input voltage to change in  $V_{KA}$  voltage vs. temperature

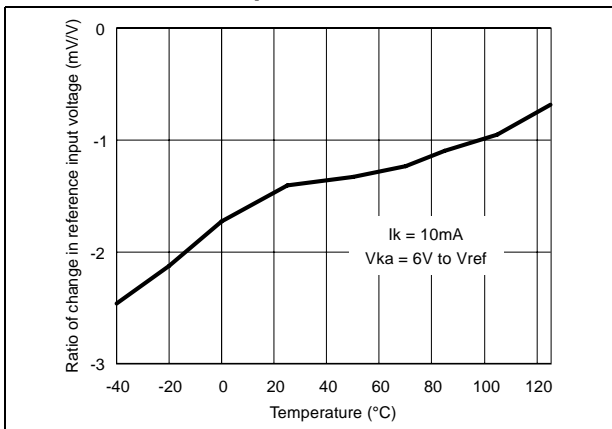

Figure 11. Test circuit for  $V_{KA} > V_{ref}$

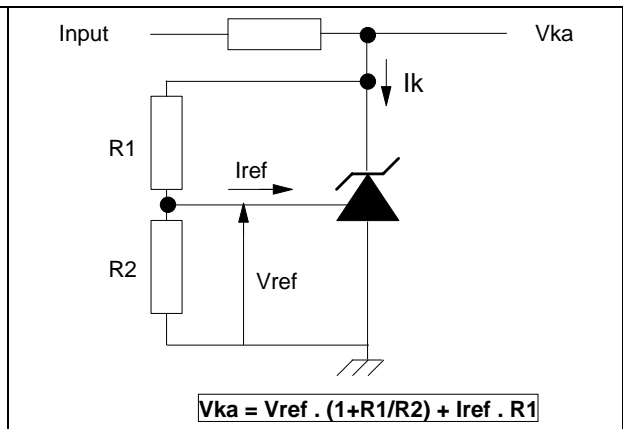

Figure 12. Phase and gain vs. frequency

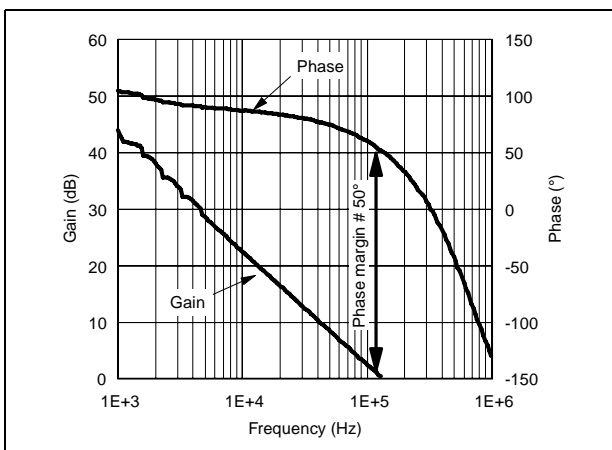

Figure 13. Test circuit for phase and gain measurement

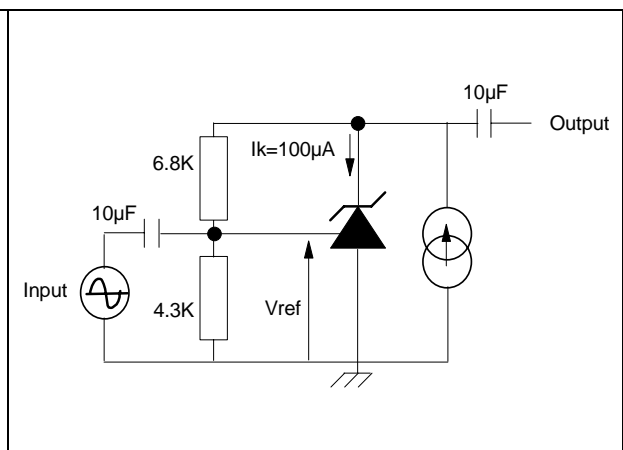

Figure 14. Pulse response at  $I_k=100\mu A$

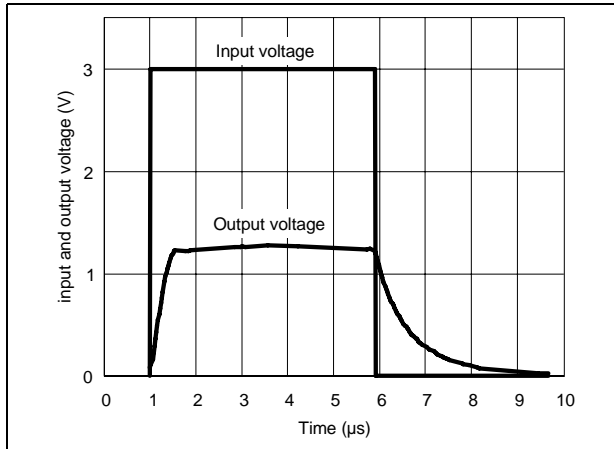

Figure 15. Test circuit for pulse response at  $I_k=100\mu A$

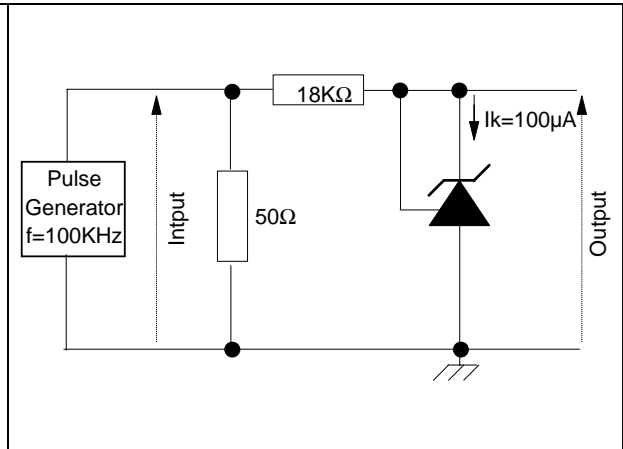

Figure 16. Pulse response at  $I_k=1mA$

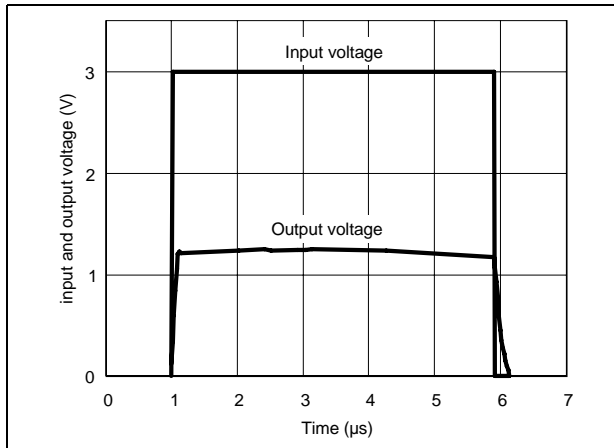

Figure 17. Test circuit for pulse response at  $I_k=1mA$

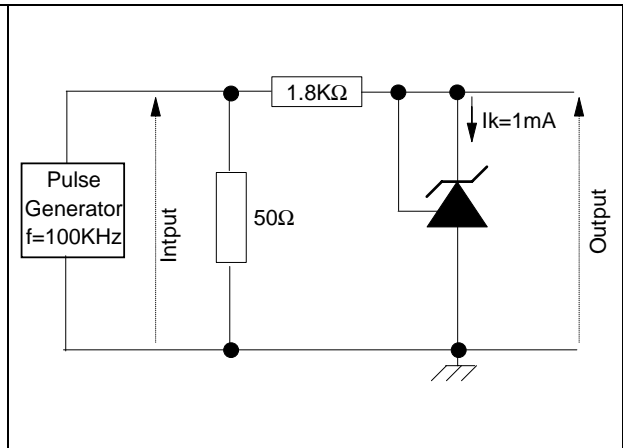
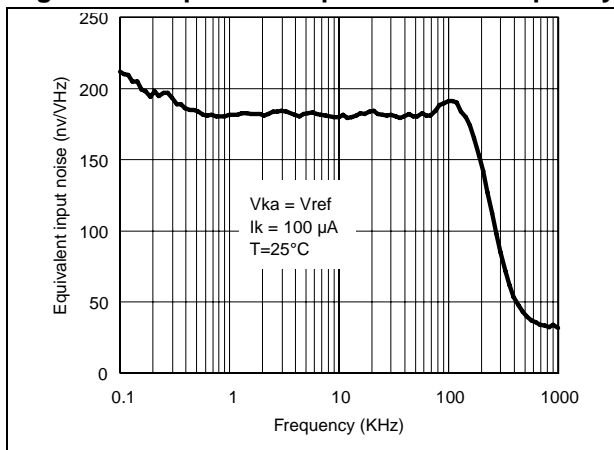

Figure 18. Equivalent input noise vs. frequency



### 3 Package information

In order to meet environmental requirements, STMicroelectronics offers these devices in ECOPACK<sup>®</sup> packages. These packages have a lead-free second level interconnect. The category of second level interconnect is marked on the package and on the inner box label, in compliance with JEDEC Standard JESD97. The maximum ratings related to soldering conditions are also marked on the inner box label. ECOPACK is an STMicroelectronics trademark. ECOPACK specifications are available at: [www.st.com](http://www.st.com).

### 3.1 SOT23-5 package mechanical data

Ref.	Dimensions					
	Millimeters			Inches		
	Min.	Typ.	Max.	Min.	Typ.	Max.
A	0.90		1.45	0.035		0.057
A1	0.00		0.15	0.00		0.006
A2	0.90		1.30	0.035		0.051
b	0.35		0.50	0.014		0.02
C	0.09		0.20	0.003		0.008
D	2.80		3.00	0.110		0.118
H	2.60		3.00	0.102		0.118
E	1.50		1.75	0.059		0.069
e		0.95			0.037	
e1		1.9			0.075	
L	0.35		0.55	0.014		0.022

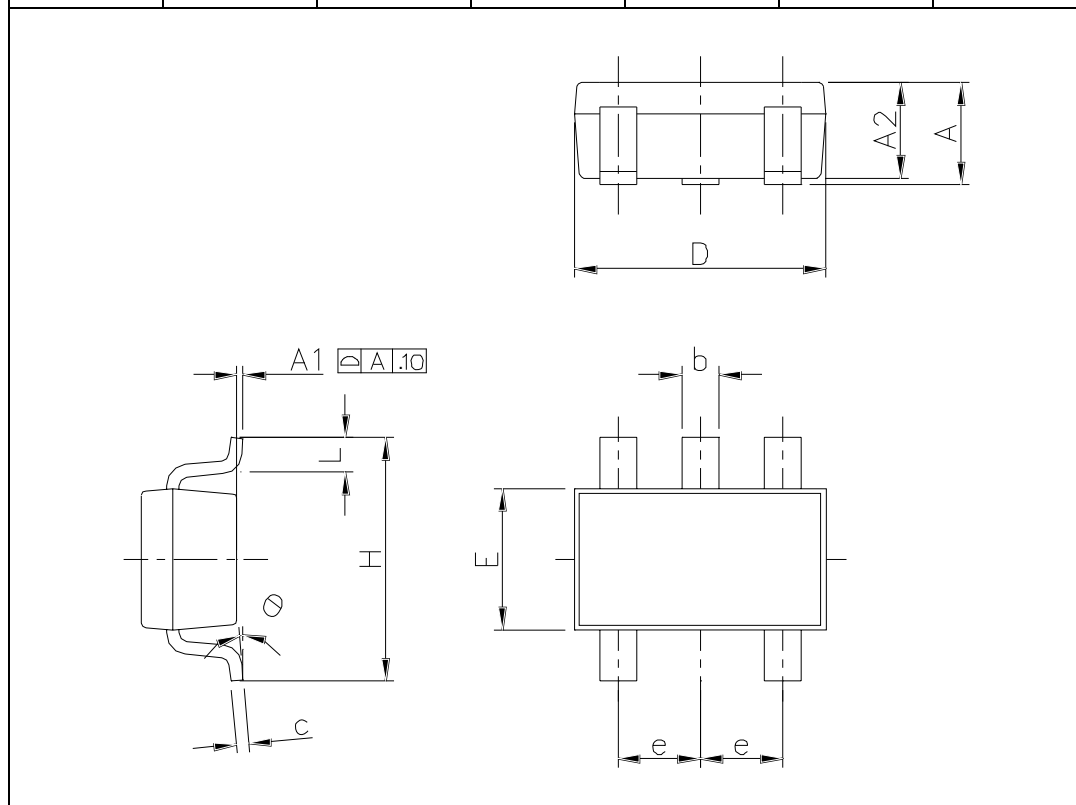



### 3.2 TO92 (tape ammo pack and tape & reel) package data

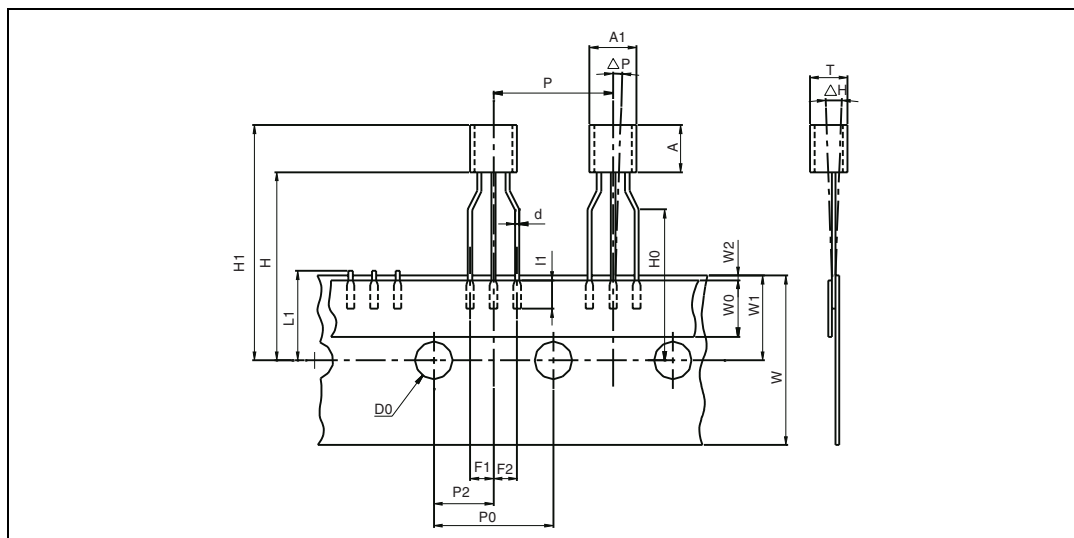

Dim.	Millimeters			Inches		
	Min.	Typ.	Max.	Min.	Typ.	Max.
AL			5.0			0.197
A			5.0			0.197
T			4.0			0.157
d		0.45			0.018	
I1	2.5			0.098		
P	11.7	12.7	13.7	0.461	0.500	0.539
PO	12.4	12.7	13	0.488	0.500	0.512
P2	5.95	6.35	6.75	0.234	0.250	0.266
F1/F2	2.4	2.5	2.8	0.094	0.098	0.110
Δh	-1	0	1	-0.039	0	0.039
ΔP	-1	0	1	-0.039	0	0.039
W	17.5	18.0	19.0	0.689	0.709	0.748
W0	5.7	6	6.3	0.224	0.236	0.248
W1	8.5	9	9.75	0.335	0.354	0.384
W2			0.5			0.020
H			20			0.787
H0	15.5	16	16.5	0.610	0.630	0.650
H1			25			0.984
DO	3.8	4.0	4.2	0.150	0.157	0.165
L1			11			0.433

### 3.3 TO92 (bulk) package mechanical data

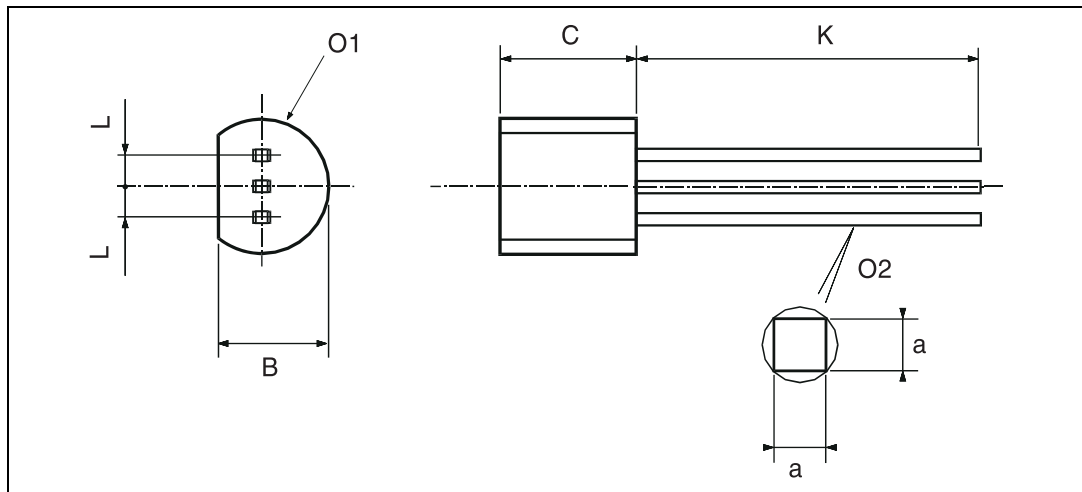

Dim.	Millimeters			Inches		
	Min.	Typ.	Max.	Min.	Typ.	Max.
L		1.27			0.05	
B	3.2	3.7	4.2	0.126	0.1457	0.1654
O1	4.45	5.00	5.2	0.1752	0.1969	0.2047
C	4.58	5.03	5.33	0.1803	0.198	0.2098
K	12.7			0.5		
O2	0.407	0.5	0.508	0.016	0.0197	0.02
a	0.35			0.0138		

## 4 Ordering information

**Table 4. Order codes**

Part number	Temperature range	Package	Packing	Marking
TS431ILT	-40°C, + 125°C	SOT23-5	Tape & reel	L272
TS431AILT				L271
TS431BILT				L270
TS431IYLT <sup>(1)</sup>		SOT23-5 (automotive grade level)		L274
TS431AIYLT <sup>(1)</sup>				L276
TS431BIYLT <sup>(1)</sup>				L273
TS431IZ/IZT/IZ-AP		TO92	Bulk (Z), Tape & reel (ZT) or Ammo pack (AP)	TS431I
TS431AIZ/AIZT/AIZ-AP				TS431AI
TS431BIZ/BIZT/BIZ-AP				TS431BI

1. Qualification and characterization according to AEC Q100 and Q003 or equivalent, advanced screening according to AEC Q001 & Q 002 or equivalent are on-going.

## 5 Revision history

**Table 5. Document revision history**

Date	Revision	Changes
1-Sep-2003	1	Initial release.
1-Oct-2005	2	PPAP references inserted in the datasheet. See the order codes table. Minor changes to formatting and grammar.
2-Jan-2006	3	TS431AIYLT PPAP reference inserted. See the order codes table.
22-Sep-2006	4	Included footnote on automotive grade qualification to order codes table. Updated package information (changed mils to inches).
25-Apr-2007	5	Resized graphics on cover page. Moved definition of output voltage change from <a href="#">Table 3</a> footnote to separate section below table. Corrected errors in SOT23-5 package mechanical data. Removed erroneous drawing for TO92 tape & reel package.
30-Aug-2007	6	Updated drawing for TO92 bulk package. Modified footnote related to automotive grade qualification in <a href="#">Table 4: Order codes</a> , and re-ordered order codes.

**Please Read Carefully:**

Information in this document is provided solely in connection with ST products. STMicroelectronics NV and its subsidiaries ("ST") reserve the right to make changes, corrections, modifications or improvements, to this document, and the products and services described herein at any time, without notice.

All ST products are sold pursuant to ST's terms and conditions of sale.

Purchasers are solely responsible for the choice, selection and use of the ST products and services described herein, and ST assumes no liability whatsoever relating to the choice, selection or use of the ST products and services described herein.

No license, express or implied, by estoppel or otherwise, to any intellectual property rights is granted under this document. If any part of this document refers to any third party products or services it shall not be deemed a license grant by ST for the use of such third party products or services, or any intellectual property contained therein or considered as a warranty covering the use in any manner whatsoever of such third party products or services or any intellectual property contained therein.

**UNLESS OTHERWISE SET FORTH IN ST'S TERMS AND CONDITIONS OF SALE ST DISCLAIMS ANY EXPRESS OR IMPLIED WARRANTY WITH RESPECT TO THE USE AND/OR SALE OF ST PRODUCTS INCLUDING WITHOUT LIMITATION IMPLIED WARRANTIES OF MERCHANTABILITY, FITNESS FOR A PARTICULAR PURPOSE (AND THEIR EQUIVALENTS UNDER THE LAWS OF ANY JURISDICTION), OR INFRINGEMENT OF ANY PATENT, COPYRIGHT OR OTHER INTELLECTUAL PROPERTY RIGHT.**

**UNLESS EXPRESSLY APPROVED IN WRITING BY AN AUTHORIZED ST REPRESENTATIVE, ST PRODUCTS ARE NOT RECOMMENDED, AUTHORIZED OR WARRANTED FOR USE IN MILITARY, AIR CRAFT, SPACE, LIFE SAVING, OR LIFE SUSTAINING APPLICATIONS, NOR IN PRODUCTS OR SYSTEMS WHERE FAILURE OR MALFUNCTION MAY RESULT IN PERSONAL INJURY, DEATH, OR SEVERE PROPERTY OR ENVIRONMENTAL DAMAGE. ST PRODUCTS WHICH ARE NOT SPECIFIED AS "AUTOMOTIVE GRADE" MAY ONLY BE USED IN AUTOMOTIVE APPLICATIONS AT USER'S OWN RISK.**

Resale of ST products with provisions different from the statements and/or technical features set forth in this document shall immediately void any warranty granted by ST for the ST product or service described herein and shall not create or extend in any manner whatsoever, any liability of ST.

ST and the ST logo are trademarks or registered trademarks of ST in various countries.

Information in this document supersedes and replaces all information previously supplied.

The ST logo is a registered trademark of STMicroelectronics. All other names are the property of their respective owners.

© 2007 STMicroelectronics - All rights reserved

STMicroelectronics group of companies

Australia - Belgium - Brazil - Canada - China - Czech Republic - Finland - France - Germany - Hong Kong - India - Israel - Italy - Japan - Malaysia - Malta - Morocco - Singapore - Spain - Sweden - Switzerland - United Kingdom - United States of America

[www.st.com](http://www.st.com)