

TS3USB221 High-Speed USB 2.0 (480-Mbps) 1:2 Multiplexer – Demultiplexer Switch With Single Enable

1 Features

- V_{CC} Operation from 2.3 V and 3.6 V
- $V_{I/O}$ Accepts Signals up to 5.5 V
- 1.8-V Compatible Control-Pin Inputs
- Low-Power Mode When \overline{OE} Is Disabled (1 μ A)
- $r_{ON} = 6 \Omega$ Maximum
- $\Delta r_{ON} = 0.2 \Omega$ Typical
- $C_{io(on)} = 6$ pF Maximum
- Low Power Consumption (30 μ A Maximum)
- ESD > 2000-V Human-Body Model (HBM)
- High Bandwidth (1.1 GHz Typical)

2 Applications

- Routes Signals for USB 1.0, 1.1, and 2.0
- Mobile Industry Processor Interface (MIPI™) Signal Routing
- MHL 1.0

Block Diagram

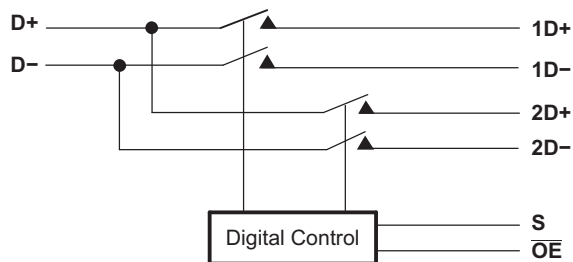

3 Description

The TS3USB221 is a high-bandwidth switch specially designed for the switching of high-speed USB 2.0 signals in handset and consumer applications, such as cell phones, digital cameras, and notebooks with hubs or controllers with limited USB I/Os. The wide bandwidth (1.1 GHz) of this switch allows signals to pass with minimum edge and phase distortion. The device multiplexes differential outputs from a USB host device to one of two corresponding outputs. The switch is bidirectional and offers little or no attenuation of the high-speed signals at the outputs. The TS3USB221 is designed for low bit-to-bit skew and high channel to channel noise isolation. The TS3USB221 is also compatible with various standards, such as high-speed USB 2.0 (480 Mbps).

Device Information⁽¹⁾

PART NUMBER	PACKAGE	BODY SIZE (NOM)
TS3USB221	VSON (10)	3.00 mm x 3.00 mm
	UQFN (10)	1.50 mm x 2.00 mm

(1) For all available packages, see the orderable addendum at the end of the data sheet.

Simplified Schematic, Each FET Switch (SW)

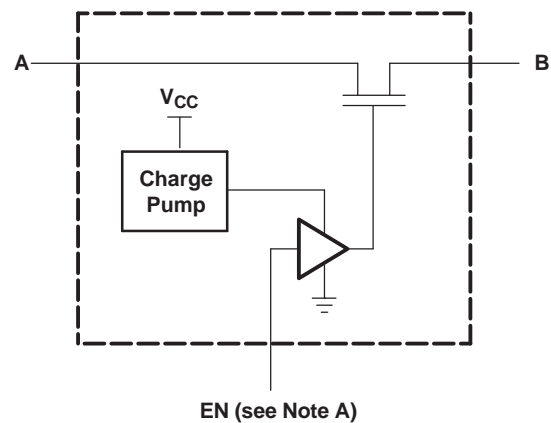

- A. EN is the internal enable signal applied to the switch.



Table of Contents

1 Features 1 2 Applications 1 3 Description 1 4 Revision History 2 5 Pin Configuration and Functions 3 6 Specifications 4 6.1 Absolute Maximum Ratings 4 6.2 ESD Ratings 4 6.3 Recommended Operating Conditions 4 6.4 Thermal Information 4 6.5 Electrical Characteristics 5 6.6 Dynamic Electrical Characteristics, $V_{CC} = 3.3\text{ V} \pm 10\%$ 6 6.7 Dynamic Electrical Characteristics, $V_{CC} = 2.5\text{ V} \pm 10\%$ 6 6.8 Switching Characteristics, $V_{CC} = 3.3\text{ V} \pm 10\%$ 6 6.9 Switching Characteristics, $V_{CC} = 2.5\text{ V} \pm 10\%$ 6 6.10 Typical Characteristics 7 7 Parameter Measurement Information 8	8 Detailed Description 12 8.1 Overview 12 8.2 Functional Block Diagram 12 8.3 Feature Description 12 8.4 Device Functional Modes 12 9 Application and Implementation 13 9.1 Application Information 13 9.2 Typical Application 13 10 Power Supply Recommendations 15 11 Layout 15 11.1 Layout Guidelines 15 11.2 Layout Example 16 12 Device and Documentation Support 17 12.1 Documentation Support 17 12.2 Trademarks 17 12.3 Electrostatic Discharge Caution 17 12.4 Glossary 17 13 Mechanical, Packaging, and Orderable Information 17
--	---

4 Revision History

NOTE: Page numbers for previous revisions may differ from page numbers in the current version.

Changes from Revision H (February 2015) to Revision I	Page
• Changed V_{IH} Max from 5.5 to V_{CC} in <i>Recommended Operating Conditions</i> table	4

Changes from Revision G (September 2010) to Revision H	Page
• Changed first bullet of the Features FROM: V_{CC} Operation at 2.5 V and 3.3 V TO: V_{CC} Operation at 2.3 V and 3.6 V	1
• Added <i>Pin Configuration and Functions</i> section, <i>ESD Ratings</i> table, <i>Feature Description</i> section, <i>Device Functional Modes</i> , <i>Application and Implementation</i> section, <i>Power Supply Recommendations</i> section, <i>Layout</i> section, <i>Device and Documentation Support</i> section, and <i>Mechanical, Packaging, and Orderable Information</i> section	1
• Removed the <i>Ordering Information</i> table	1

5 Pin Configuration and Functions

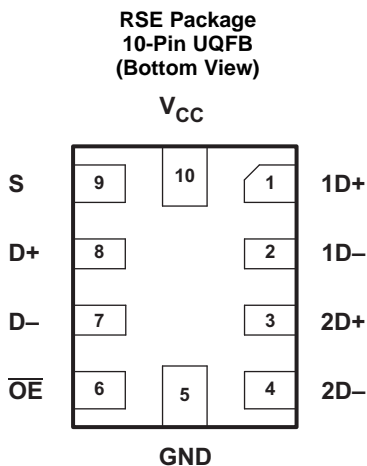
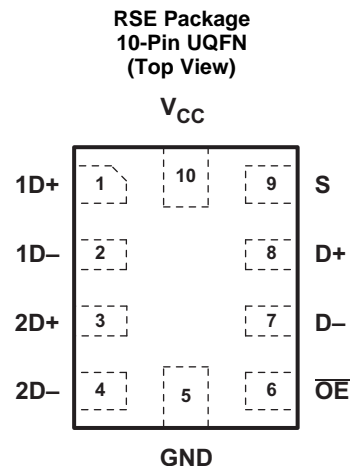
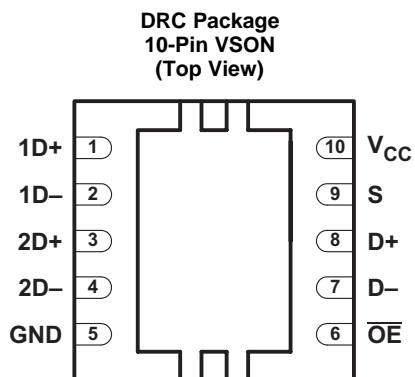

Pin Functions

PIN		I/O	DESCRIPTION
NAME	NO.		
1D+	1	I/O	USB port 1
1D-	2	I/O	
2D+	3	I/O	
2D-	4	I/O	
GND	5	—	Ground
$\overline{\text{OE}}$	6	I	Bus-switch enable
D-	7	I/O	Common USB port
D+	8	I/O	
S	9	I	Select input
V _{CC}	10	—	Supply voltage

6 Specifications

6.1 Absolute Maximum Ratings

over operating free-air temperature range (unless otherwise noted)⁽¹⁾

		MIN	MAX	UNIT
V _{CC}	Supply voltage	-0.5	4.6	V
V _{IN}	Control input voltage ^{(2) (3)}	-0.5	7	V
V _{I/O}	Switch I/O voltage ^{(2) (3) (4)}	-0.5	7	V
I _{IK}	Control input clamp current	V _{IN} < 0	-50	mA
I _{I/O} K	I/O port clamp current	V _{I/O} < 0	-50	mA
I _{I/O}	ON-state switch current ⁽⁵⁾		±120	mA
	Continuous current through V _{CC} or GND		±100	mA
T _{stg}	Storage temperature	-65	150	°C

- (1) Stresses beyond those listed under *Absolute Maximum Ratings* may cause permanent damage to the device. These are stress ratings only, and functional operation of the device at these or any other conditions beyond those indicated under *Recommended Operating Conditions* is not implied. Exposure to absolute-maximum-rated conditions for extended periods may affect device reliability.
- (2) All voltages are with respect to ground, unless otherwise specified.
- (3) The input and output voltage ratings may be exceeded if the input and output clamp-current ratings are observed.
- (4) V_I and V_O are used to denote specific conditions for V_{I/O}.
- (5) I_I and I_O are used to denote specific conditions for I_{I/O}.

6.2 ESD Ratings

		VALUE	UNIT
V _(ESD)	Electrostatic discharge	Human-body model (HBM), per ANSI/ESDA/JEDEC JS-001	2000 V

6.3 Recommended Operating Conditions

See ⁽¹⁾.

		MIN	MAX	UNIT	
V _{CC}	Supply voltage	2.3	3.6	V	
V _{IH}	High-level control input voltage	0.46 × V _{CC}	V _{CC}	V	
V _{IL}	Low-level control input voltage	V _{CC} = 2.3 V to 2.7 V	0	0.25 × V _{CC}	V
		V _{CC} = 2.7 V to 3.6 V			
V _{I/O}	Data input/output voltage	0	5.5	V	
T _A	Operating free-air temperature	-40	85	°C	

- (1) All unused control inputs of the device must be held at V_{CC} or GND to ensure proper device operation. Refer to the TI application report, *Implications of Slow or Floating CMOS Inputs*, literature number SCBA004.

6.4 Thermal Information

THERMAL METRIC ⁽¹⁾		TS3USB221		UNIT
		DRC (VSON)	RSE (UQFN)	
		10 PINS	10 PINS	
R _{θJA}	Junction-to-ambient thermal resistance	57.7	169.8	°C/W
R _{θJC(top)}	Junction-to-case (top) thermal resistance	87.7	84.7	
R _{θJB}	Junction-to-board thermal resistance	32.6	94.9	
ψ _{JT}	Junction-to-top characterization parameter	8.2	5.7	
ψ _{JB}	Junction-to-board characterization parameter	32.8	94.9	
R _{θJC(bot)}	Junction-to-case (bottom) thermal resistance	18.5	N/A	

- (1) For more information about traditional and new thermal metrics, see the *IC Package Thermal Metrics* application report, [SPRA953](#).

6.5 Electrical Characteristics

over operating free-air temperature range (unless otherwise noted)⁽¹⁾

PARAMETER	TEST CONDITIONS		MIN	TYP ⁽²⁾	MAX	UNIT
V _{IK}	V _{CC} = 3.6 V, 2.7 V, I _I = -18 mA				-1.8	V
I _{IN}	Control inputs	V _{CC} = 3.6 V, 2.7 V, 0 V, V _{IN} = 0 V to 3.6 V			±1	μA
I _{OZ} ⁽³⁾		V _{CC} = 3.6 V, 2.7 V, V _O = 0 V to 3.6 V, V _I = 0 V, V _{IN} = V _{CC} or GND, Switch OFF			±1	μA
I _{OFF}		V _{CC} = 0 V	V _{I/O} = 0 V to 3.6 V		±2	μA
			V _{I/O} = 0 V to 2.7 V		±1	
I _{CC}		V _{CC} = 3.6 V, 2.7 V, V _{IN} = V _{CC} or GND, I _{I/O} = 0 V, Switch ON or OFF			30	μA
I _{CC} (low power mode)		V _{CC} = 3.6 V, 2.7 V, V _{IN} = V _{CC} or GND, Switch disabled (OE in high state)			1	μA
ΔI _{CC} ⁽⁴⁾	Control inputs	One input at 1.8 V, Other inputs at V _{CC} or GND	V _{CC} = 3.6 V		20	μA
			V _{CC} = 2.7 V		0.5	
C _{in}	Control inputs	V _{CC} = 3.3 V, 2.5 V, V _{IN} = 3.3 V or 0 V		1	2	pF
C _{io(OFF)}		V _{CC} = 3.3 V, 2.5 V, V _{I/O} = 3.3 V or 0 V, Switch OFF		3	4	pF
C _{io(ON)}		V _{CC} = 3.3 V, 2.5 V, V _{I/O} = 3.3 V or 0 V, Switch ON		5	6	pF
r _{on} ⁽⁵⁾		V _{CC} = 3 V, 2.3 V	V _I = 0 V, I _O = 30 mA		6	Ω
			V _I = 2.4 V, I _O = -15 mA		6	
Δr _{on}		V _{CC} = 3 V, 2.3 V	V _I = 0 V, I _O = 30 mA	0.2		Ω
			V _I = 1.7, I _O = -15 mA	0.2		
r _{on(flat)}		V _{CC} = 3 V, 2.3 V	V _I = 0 V, I _O = 30 mA	1		Ω
			V _I = 1.7, I _O = -15 mA	1		

(1) V_{IN} and I_{IN} refer to control inputs. V_I, V_O, I_I, and I_O refer to data pins.

(2) All typical values are at V_{CC} = 3.3 V (unless otherwise noted), T_A = 25°C.

(3) For I/O ports, the parameter I_{OZ} includes the input leakage current.

(4) This is the increase in supply current for each input that is at the specified TTL voltage level, rather than V_{CC} or GND.

(5) Measured by the voltage drop between the A and B terminals at the indicated current through the switch. ON-state resistance is determined by the lower of the voltages of the two (A or B) terminals.

6.6 Dynamic Electrical Characteristics, $V_{CC} = 3.3 V \pm 10\%$

 over operating range, $T_A = -40^\circ\text{C}$ to 85°C , $V_{CC} = 3.3 V \pm 10\%$, $GND = 0 V$

PARAMETER		TEST CONDITIONS	TYP ⁽¹⁾	UNIT
X_{TALK}	Crosstalk	$R_L = 50 \Omega$, $f = 250 \text{ MHz}$	-40	dB
O_{IRR}	OFF isolation	$R_L = 50 \Omega$, $f = 250 \text{ MHz}$	-41	dB
BW	Bandwidth (-3 dB)	$R_L = 50 \Omega$	1.1	GHz

 (1) For Maximum or Minimum conditions, use the appropriate value specified under [Electrical Characteristics](#) for the applicable device type.

6.7 Dynamic Electrical Characteristics, $V_{CC} = 2.5 V \pm 10\%$

 over operating range, $T_A = -40^\circ\text{C}$ to 85°C , $V_{CC} = 2.5 V \pm 10\%$, $GND = 0 V$

PARAMETER		TEST CONDITIONS	TYP ⁽¹⁾	UNIT
X_{TALK}	Crosstalk	$R_L = 50 \Omega$, $f = 250 \text{ MHz}$	-39	dB
O_{IRR}	OFF isolation	$R_L = 50 \Omega$, $f = 250 \text{ MHz}$	-40	dB
BW	Bandwidth (-3 dB)	$R_L = 50 \Omega$	1.1	GHz

 (1) For Maximum or Minimum conditions, use the appropriate value specified under [Electrical Characteristics](#) for the applicable device type.

6.8 Switching Characteristics, $V_{CC} = 3.3 V \pm 10\%$

 over operating range, $T_A = -40^\circ\text{C}$ to 85°C , $V_{CC} = 3.3 V \pm 10\%$, $GND = 0 V$

PARAMETER		MIN	TYP ⁽¹⁾	MAX	UNIT
t_{pd}	Propagation delay ^{(2) (3)}		0.25		ns
t_{ON}	Line enable time	S to D, nD		30	ns
		\overline{OE} to D, nD		17	
t_{OFF}	Line disable time	S to D, nD		12	ns
		\overline{OE} to D, nD		10	
$t_{SK(O)}$	Output skew between center port to any other port ⁽²⁾		0.1	0.2	ns
$t_{SK(P)}$	Skew between opposite transitions of the same output ($t_{PHL} - t_{PLH}$) ⁽²⁾		0.1	0.2	ns

 (1) For Maximum or Minimum conditions, use the appropriate value specified under [Electrical Characteristics](#) for the applicable device type.

(2) Specified by design

(3) The bus switch contributes no propagational delay other than the RC delay of the on resistance of the switch and the load capacitance. The time constant for the switch alone is of the order of 0.25 ns for 10-pF load. This time constant adds very little propagational delay to the system because it is much smaller than the rise/fall times of typical driving signals. Propagational delay of the bus switch, when used in a system, is determined by the driving circuit on the driving side of the switch and its interactions with the load on the driven side.

6.9 Switching Characteristics, $V_{CC} = 2.5 V \pm 10\%$

 over operating range, $T_A = -40^\circ\text{C}$ to 85°C , $V_{CC} = 2.5 V \pm 10\%$, $GND = 0 V$

PARAMETER		MIN	TYP ⁽¹⁾	MAX	UNIT
t_{pd}	Propagation delay ^{(2) (3)}		0.25		ns
t_{ON}	Line enable time	S to D, nD		50	ns
		\overline{OE} to D, nD		32	
t_{OFF}	Line disable time	S to D, nD		23	ns
		\overline{OE} to D, nD		12	
$t_{SK(O)}$	Output skew between center port to any other port ⁽²⁾		0.1	0.2	ns
$t_{SK(P)}$	Skew between opposite transitions of the same output ($t_{PHL} - t_{PLH}$) ⁽²⁾		0.1	0.2	ns

 (1) For Maximum or Minimum conditions, use the appropriate value specified under [Electrical Characteristics](#) for the applicable device type.

(2) Specified by design

(3) The bus switch contributes no propagational delay other than the RC delay of the on resistance of the switch and the load capacitance. The time constant for the switch alone is of the order of 0.25 ns for 10-pF load. The time constraint adds very little propagational delay to the system because it is much smaller than the rise and fall times of typical driving signals. Propagational delay of the bus switch, when used in a system, is determined by the driving circuit on the driving side of the switch and its interactions with the load on the driven side.

6.10 Typical Characteristics

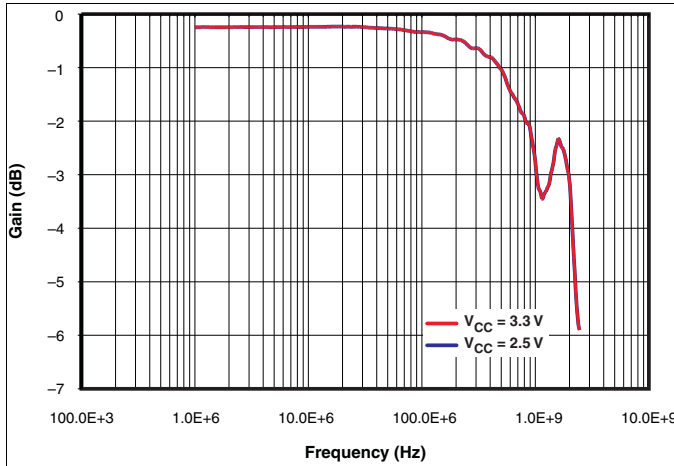

Figure 1. Gain vs Frequency

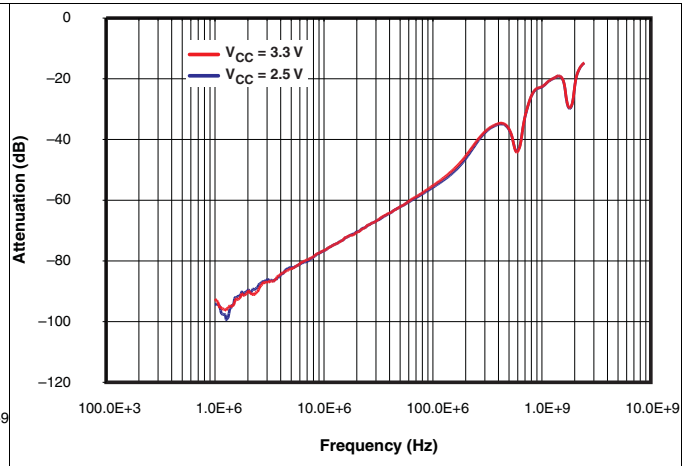

Figure 2. OFF Isolation vs Frequency

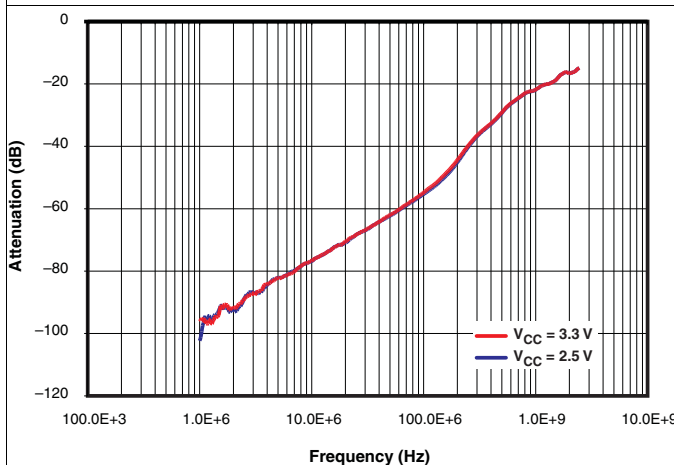

Figure 3. Crosstalk vs Frequency

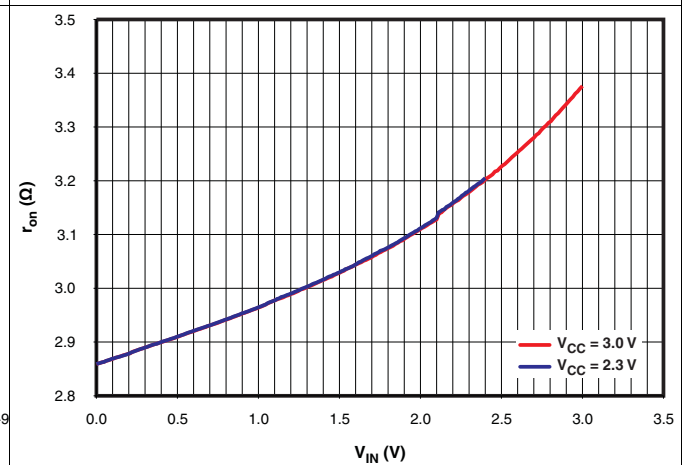

Figure 4. r_{on} vs V_{IN} ($I_{OUT} = -15$ mA)

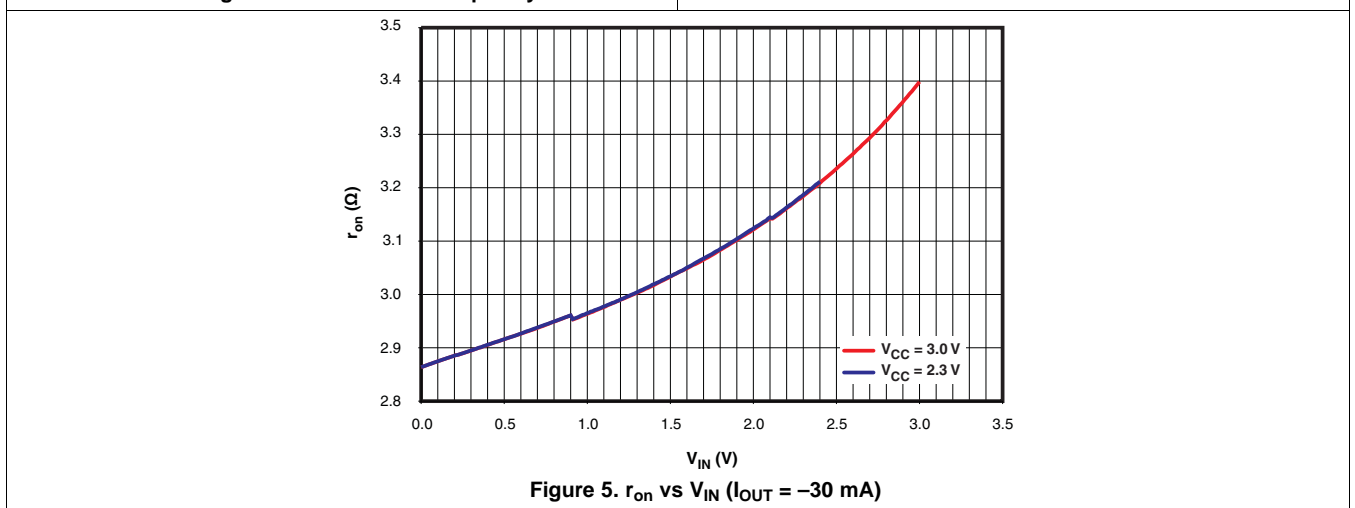
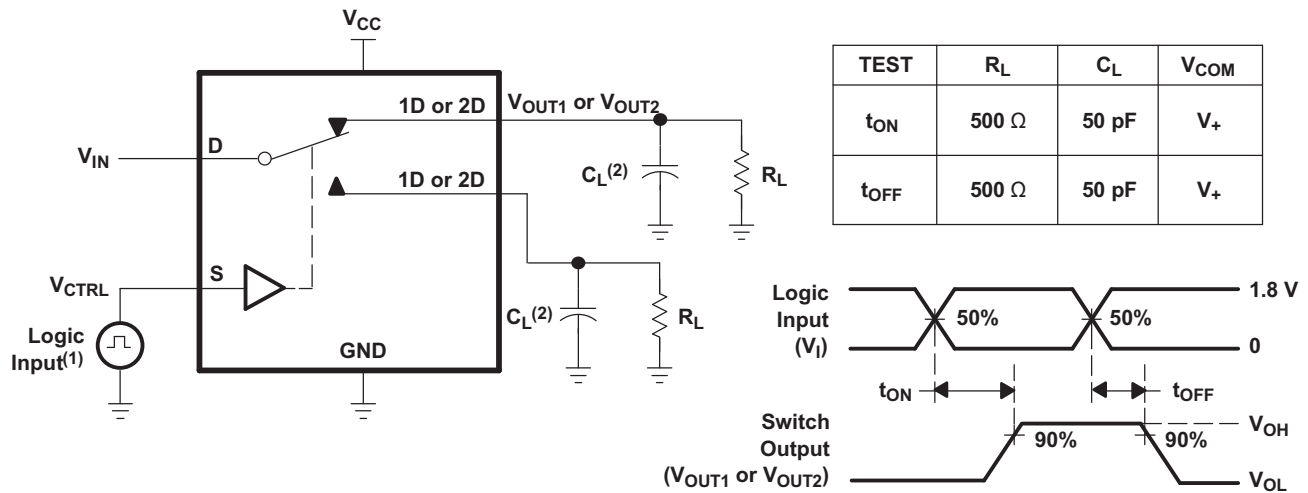

Figure 5. r_{on} vs V_{IN} ($I_{OUT} = -30$ mA)

7 Parameter Measurement Information



- (1) All input pulses are supplied by generators having the following characteristics: PRR ≤ 10 MHz, Z_O = 50 Ω, t_r < 5 ns, t_f < 5 ns.
- (2) C_L includes probe and jig capacitance.

Figure 6. Turnon (t_{ON}) and Turnoff Time (t_{OFF})

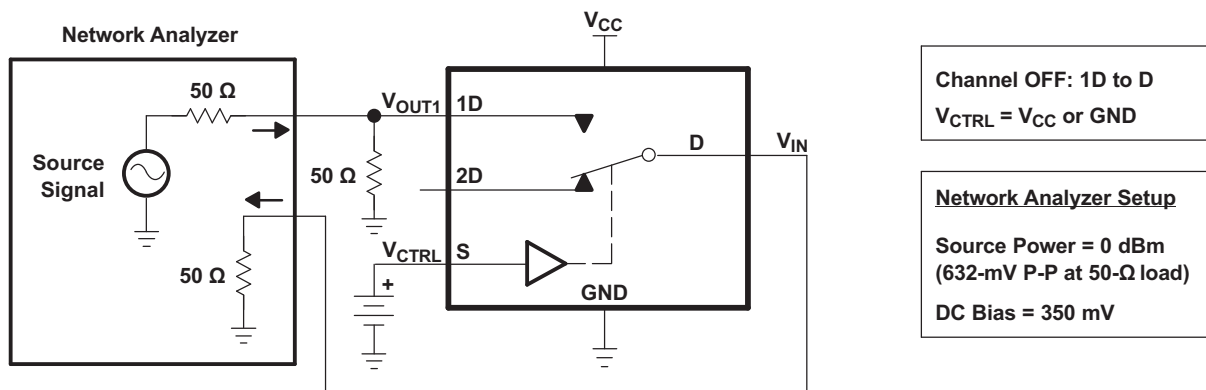

Figure 7. OFF Isolation (O_{ISO})

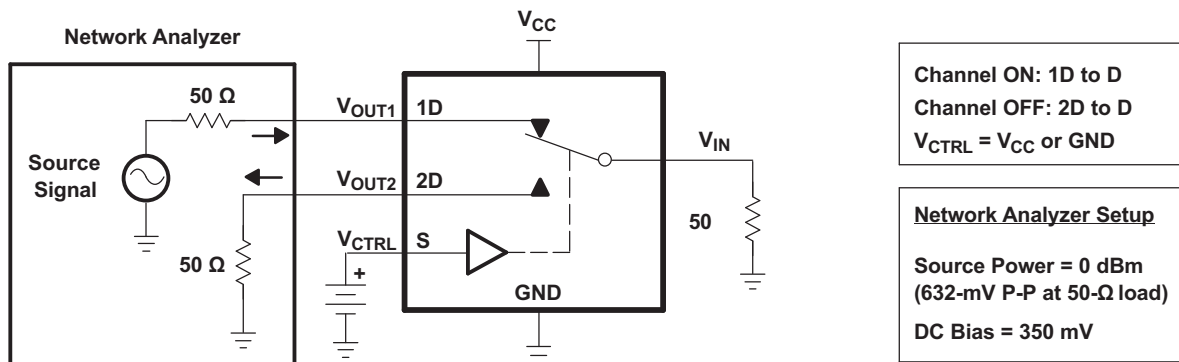

Figure 8. Crosstalk (X_{TALK})

Parameter Measurement Information (continued)

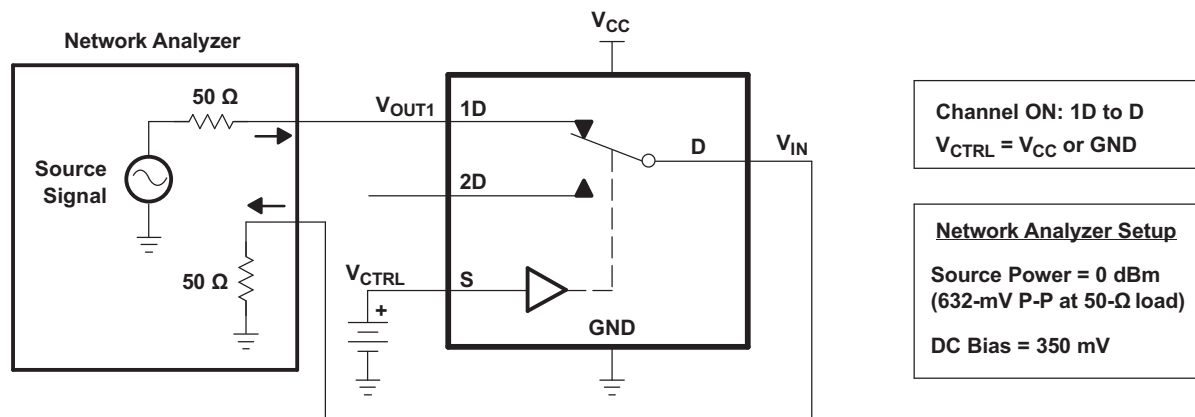

Figure 9. Bandwidth (BW)

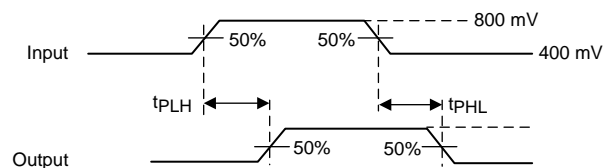

Figure 10. Propagation Delay

Parameter Measurement Information (continued)

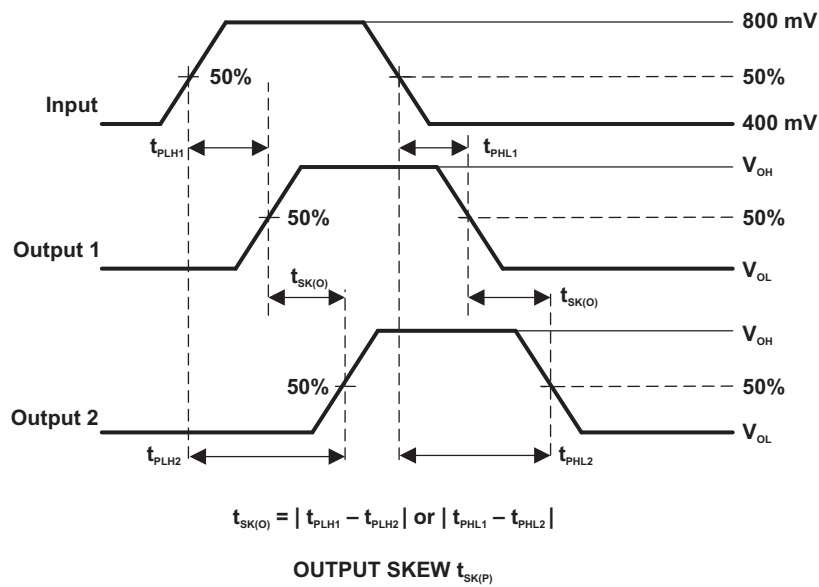
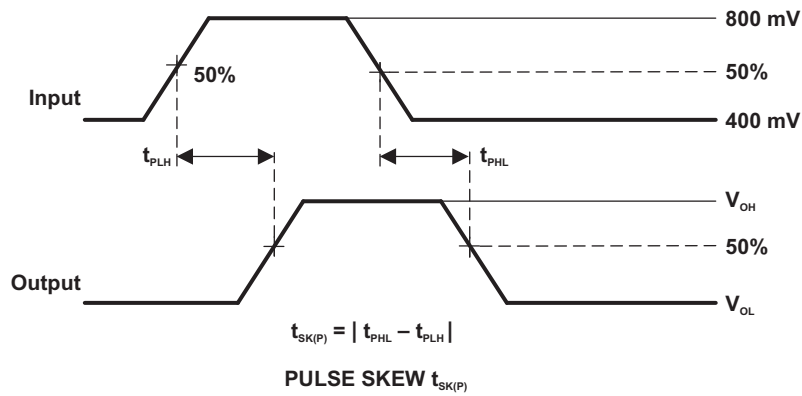

Figure 11. Skew Test

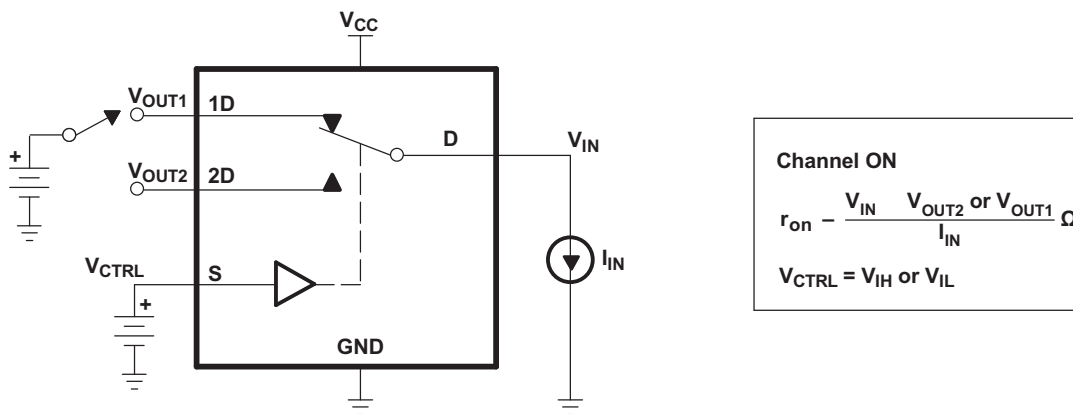

Figure 12. ON-State Resistance (r_{on})

Parameter Measurement Information (continued)

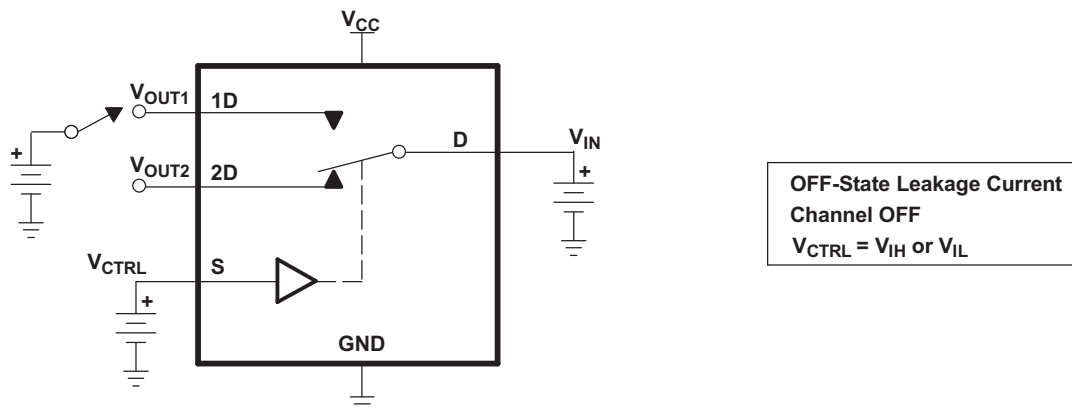

Figure 13. OFF-State Leakage Current

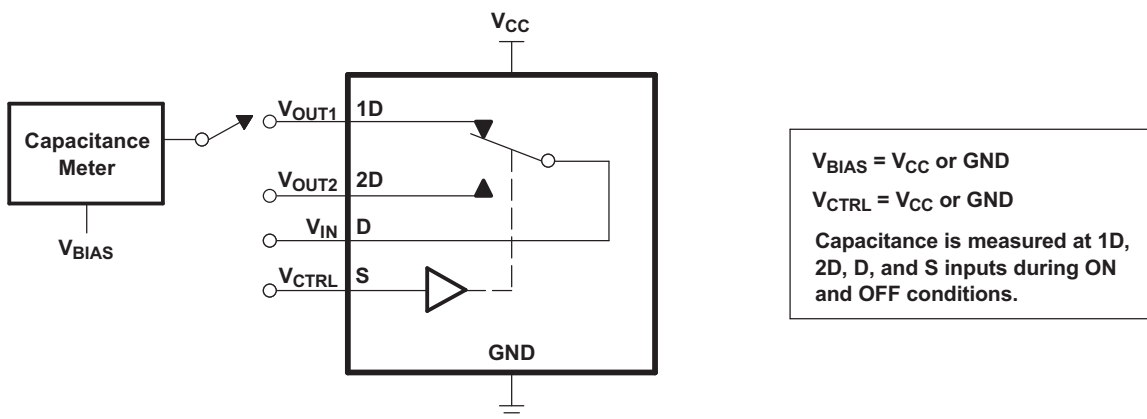

Figure 14. Capacitance

8 Detailed Description

8.1 Overview

The TS3USB221 device is a 2-channel SPDT switch specially designed for the switching of high-speed USB 2.0 signals in handset and consumer applications, such as cell phones, digital cameras, and notebooks with hubs or controllers with limited USB I/Os. The wide bandwidth (1.1 GHz) of this switch allows signals to pass with minimum edge and phase distortion. The device multiplexes differential outputs from a USB host device to one of two corresponding outputs. The switch is bidirectional and offers little or no attenuation of the high-speed signals at the outputs. The device also has a low power mode that reduces the power consumption to 1 μ A for portable applications with a battery or limited power budget.

The device is designed for low bit-to-bit skew and high channel-to-channel noise isolation, and is compatible with various standards, such as high-speed USB 2.0 (480 Mbps).

The TS3USB221 device integrates ESD protection cells on all pins, is available in a tiny μ QFN package (2 mm \times 1.5 mm) and is characterized over the free-air temperature range from -40°C to 85°C .

8.2 Functional Block Diagram

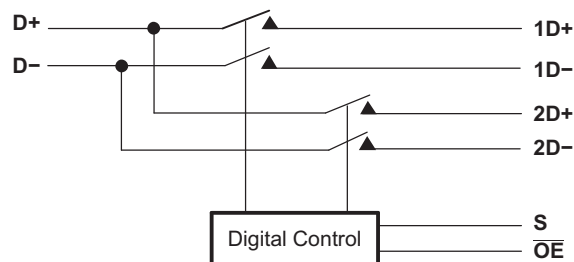

8.3 Feature Description

8.3.1 Low Power Mode

The TS3USB221 has a low power mode that reduces the power consumption to 1 μ A when the device is not in use. The bus-switch enable pin $\overline{\text{OE}}$ must be supplied with a logic high signal to put the device in low power mode and disable the switch.

8.4 Device Functional Modes

Table 1. Truth Table

S	$\overline{\text{OE}}$	FUNCTION
X	H	Disconnect
L	L	D = 1D
H	L	D = 2D

9 Application and Implementation

NOTE

Information in the following applications sections is not part of the TI component specification, and TI does not warrant its accuracy or completeness. TI's customers are responsible for determining suitability of components for their purposes. Customers should validate and test their design implementation to confirm system functionality.

9.1 Application Information

There are many USB applications in which the USB hubs or controllers have a limited number of USB I/Os. The TS3USB221 solution can effectively expand the limited USB I/Os by switching between multiple USB buses in order to interface them to a single USB hub or controller. TS3USB221 can also be used to connect a single controller to two USB connectors.

9.2 Typical Application

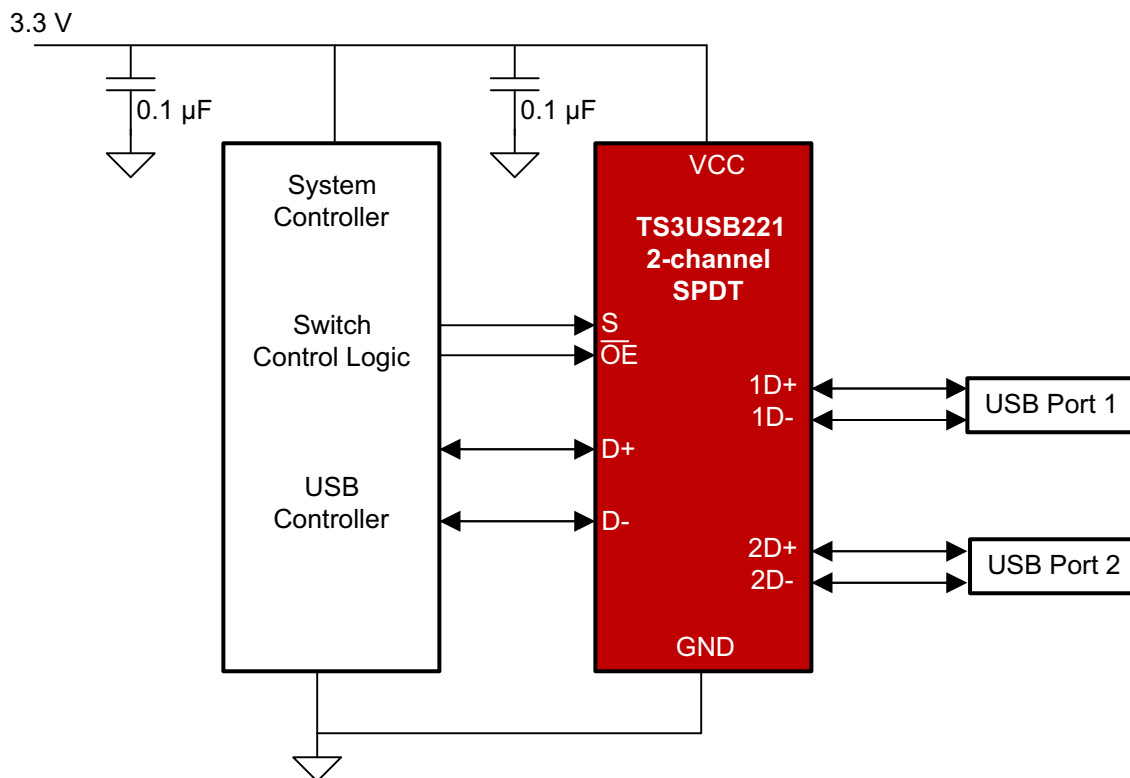

Figure 15. Simplified Schematic

9.2.1 Design Requirements

Design requirements of the USB 1.0, 1.1, and 2.0 standards should be followed.

TI recommends that the digital control pins S and \overline{OE} be pulled up to V_{CC} or down to GND to avoid undesired switch positions that could result from the floating pin.

9.2.2 Detailed Design Procedure

The TS3USB221 may be properly operated without any external components. However, it is recommended that unused pins be connected to ground through a 50-Ω resistor to prevent signal reflections back into the device.

Typical Application (continued)

9.2.3 Application Curves

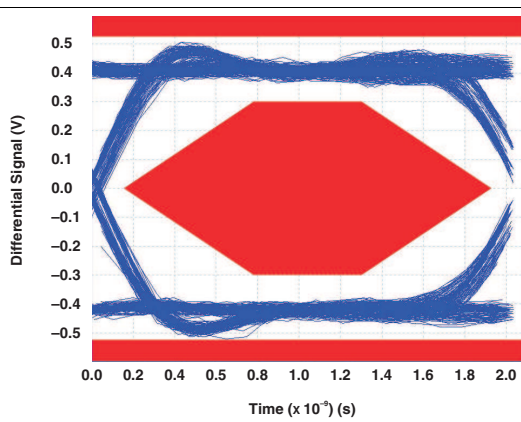

Figure 16. Eye Pattern: 480-Mbps USB Signal With No Switch (Through Path)

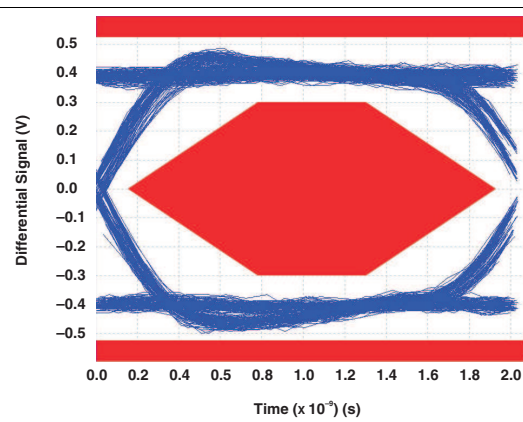

Figure 17. Eye Pattern: 480-Mbps USB Signal With Switch NC Path

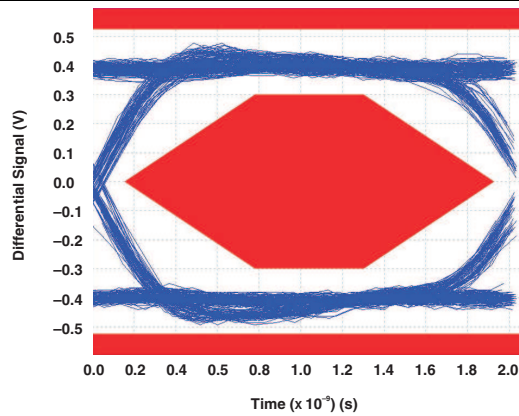

Figure 18. Eye Pattern: 480-Mbps USB Signal With Switch NO Path

10 Power Supply Recommendations

Power to the device is supplied through the V_{CC} pin and should follow the USB 1.0, 1.1, and 2.0 standards. TI recommends placing a bypass capacitor as close as possible to the supply pin V_{CC} to help smooth out lower frequency noise to provide better load regulation across the frequency spectrum.

11 Layout

11.1 Layout Guidelines

Place supply bypass capacitors as close to V_{CC} pin as possible. Avoid placing the bypass caps near the D+/D– traces.

The high-speed D+/D– traces should always be matched lengths and must be no more than 4 inches, otherwise the eye diagram performance may be degraded. A high-speed USB connection is made through a shielded, twisted pair cable with a differential characteristic impedance. In the layout, the impedance of D+ and D– traces should match the cable characteristic differential impedance for optimal performance.

Route the high-speed USB signals using a minimum of vias and corners which will reduce signal reflections and impedance changes. When a via must be used, increase the clearance size around it to minimize its capacitance. Each via introduces discontinuities in the signal's transmission line and increases the chance of picking up interference from the other layers of the board. Be careful when designing test points on twisted pair lines; through-hole pins are not recommended.

When it becomes necessary to turn 90°, use two 45° turns or an arc instead of making a single 90° turn. This reduces reflections on the signal traces by minimizing impedance discontinuities.

Do not route USB traces under or near crystals, oscillators, clock signal generators, switching regulators, mounting holes, magnetic devices or IC's that use or duplicate clock signals.

Avoid stubs on the high-speed USB signals because they cause signal reflections. If a stub is unavoidable, then the stub should be less than 200 mm.

Route all high-speed USB signal traces over continuous planes (V_{CC} or GND), with no interruptions.

Avoid crossing over anti-etch, commonly found with plane splits.

A printed circuit board with at least four layers is recommended because of high frequencies associated with the USB; two signal layers separated by a ground and power layer as shown in [Figure 19](#).

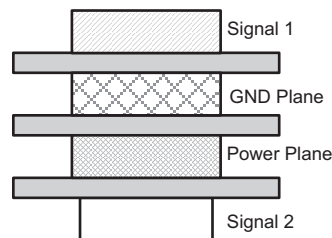

Figure 19. Four-Layer Board Stack-Up

The majority of signal traces should run on a single layer, preferably Signal 1. Immediately next to this layer should be the GND plane, which is solid with no cuts. Avoid running signal traces across a split in the ground or power plane. When running across split planes is unavoidable, sufficient decoupling must be used. Minimizing the number of signal vias reduces EMI by reducing inductance at high frequencies. For more information on layout guidelines, see *High Speed Layout Guidelines (SCAA082)* and *USB 2.0 Board Design and Layout Guidelines (SPRAAR7)*.

11.2 Layout Example

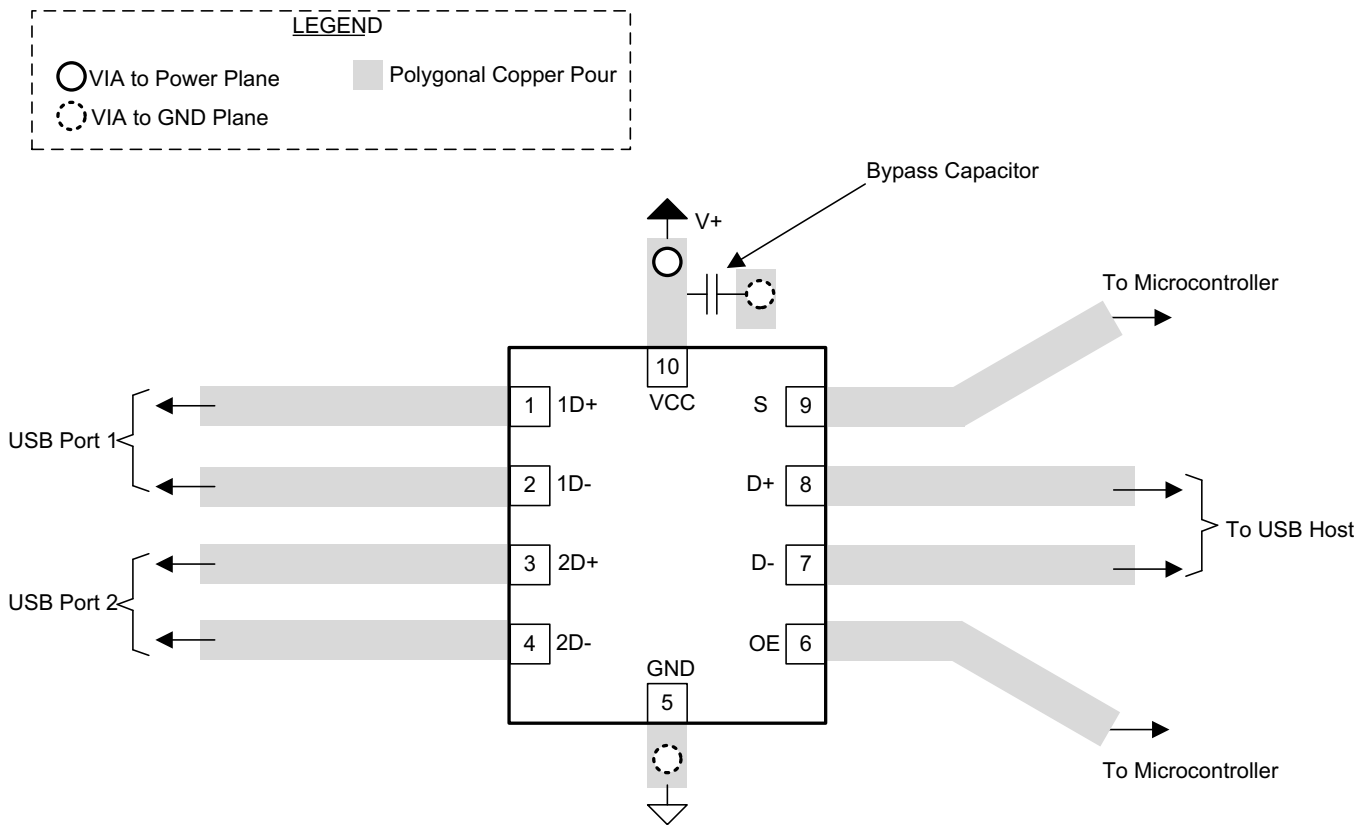

Figure 20. Package Layout Diagram

12 Device and Documentation Support

12.1 Documentation Support

12.1.1 Related Documentation

For related documentation, see the following:

- *High Speed Layout Guidelines*, [SCAA082](#)
- *USB 2.0 Board Design and Layout Guidelines*, [SPRAAR7](#)

12.2 Trademarks

MIPI is a trademark of Mobile Industry Processor Interface Alliance. All other trademarks are the property of their respective owners.

12.3 Electrostatic Discharge Caution



These devices have limited built-in ESD protection. The leads should be shorted together or the device placed in conductive foam during storage or handling to prevent electrostatic damage to the MOS gates.

12.4 Glossary

[SLYZ022](#) — *TI Glossary*.

This glossary lists and explains terms, acronyms, and definitions.

13 Mechanical, Packaging, and Orderable Information

The following pages include mechanical, packaging, and orderable information. This information is the most current data available for the designated devices. This data is subject to change without notice and revision of this document. For browser-based versions of this data sheet, refer to the left-hand navigation.

PACKAGING INFORMATION

Orderable Device	Status (1)	Package Type	Package Drawing	Pins	Package Qty	Eco Plan (2)	Lead/Ball Finish (6)	MSL Peak Temp (3)	Op Temp (°C)	Device Marking (4/5)	Samples
SN080104RSER	ACTIVE	UQFN	RSE	10	3000	Green (RoHS & no Sb/Br)	CU NIPDAU	Level-1-260C-UNLIM	-40 to 85	(L57 ~ L5O ~ L5R ~ L5V)	Samples
TS3USB221DRCR	ACTIVE	VSON	DRC	10	3000	Green (RoHS & no Sb/Br)	CU NIPDAU CU NIPDAUAG	Level-2-260C-1 YEAR	-40 to 85	ZWG	Samples
TS3USB221DRCRG4	ACTIVE	VSON	DRC	10	3000	Green (RoHS & no Sb/Br)	CU NIPDAU	Level-2-260C-1 YEAR	-40 to 85	ZWG	Samples
TS3USB221RSER	ACTIVE	UQFN	RSE	10	3000	Green (RoHS & no Sb/Br)	CU NIPDAU CU NIPDAUAG	Level-1-260C-UNLIM	-40 to 85	(L57 ~ L5O ~ L5R ~ L5V)	Samples
TS3USB221RSERG4	ACTIVE	UQFN	RSE	10	3000	Green (RoHS & no Sb/Br)	CU NIPDAU	Level-1-260C-UNLIM	-40 to 85	(L57 ~ L5O ~ L5R ~ L5V)	Samples

(1) The marketing status values are defined as follows:

ACTIVE: Product device recommended for new designs.

LIFEBUY: TI has announced that the device will be discontinued, and a lifetime-buy period is in effect.

NRND: Not recommended for new designs. Device is in production to support existing customers, but TI does not recommend using this part in a new design.

PREVIEW: Device has been announced but is not in production. Samples may or may not be available.

OBSOLETE: TI has discontinued the production of the device.

(2) Eco Plan - The planned eco-friendly classification: Pb-Free (RoHS), Pb-Free (RoHS Exempt), or Green (RoHS & no Sb/Br) - please check <http://www.ti.com/productcontent> for the latest availability information and additional product content details.

TBD: The Pb-Free/Green conversion plan has not been defined.

Pb-Free (RoHS): TI's terms "Lead-Free" or "Pb-Free" mean semiconductor products that are compatible with the current RoHS requirements for all 6 substances, including the requirement that lead not exceed 0.1% by weight in homogeneous materials. Where designed to be soldered at high temperatures, TI Pb-Free products are suitable for use in specified lead-free processes.

Pb-Free (RoHS Exempt): This component has a RoHS exemption for either 1) lead-based flip-chip solder bumps used between the die and package, or 2) lead-based die adhesive used between the die and leadframe. The component is otherwise considered Pb-Free (RoHS compatible) as defined above.

Green (RoHS & no Sb/Br): TI defines "Green" to mean Pb-Free (RoHS compatible), and free of Bromine (Br) and Antimony (Sb) based flame retardants (Br or Sb do not exceed 0.1% by weight in homogeneous material)

(3) MSL, Peak Temp. - The Moisture Sensitivity Level rating according to the JEDEC industry standard classifications, and peak solder temperature.

(4) There may be additional marking, which relates to the logo, the lot trace code information, or the environmental category on the device.

(5) Multiple Device Markings will be inside parentheses. Only one Device Marking contained in parentheses and separated by a "~" will appear on a device. If a line is indented then it is a continuation of the previous line and the two combined represent the entire Device Marking for that device.

⁽⁶⁾ Lead/Ball Finish - Orderable Devices may have multiple material finish options. Finish options are separated by a vertical ruled line. Lead/Ball Finish values may wrap to two lines if the finish value exceeds the maximum column width.

Important Information and Disclaimer:The information provided on this page represents TI's knowledge and belief as of the date that it is provided. TI bases its knowledge and belief on information provided by third parties, and makes no representation or warranty as to the accuracy of such information. Efforts are underway to better integrate information from third parties. TI has taken and continues to take reasonable steps to provide representative and accurate information but may not have conducted destructive testing or chemical analysis on incoming materials and chemicals. TI and TI suppliers consider certain information to be proprietary, and thus CAS numbers and other limited information may not be available for release.

In no event shall TI's liability arising out of such information exceed the total purchase price of the TI part(s) at issue in this document sold by TI to Customer on an annual basis.

TAPE AND REEL INFORMATION

QUADRANT ASSIGNMENTS FOR PIN 1 ORIENTATION IN TAPE

*All dimensions are nominal

Device	Package Type	Package Drawing	Pins	SPQ	Reel Diameter (mm)	Reel Width W1 (mm)	A0 (mm)	B0 (mm)	K0 (mm)	P1 (mm)	W (mm)	Pin1 Quadrant
TS3USB221DRCR	VSON	DRC	10	3000	330.0	12.4	3.3	3.3	1.0	8.0	12.0	Q2
TS3USB221RSER	UQFN	RSE	10	3000	180.0	8.4	1.68	2.13	0.76	4.0	8.0	Q1
TS3USB221RSER	UQFN	RSE	10	3000	180.0	9.5	1.7	2.3	0.75	4.0	8.0	Q1
TS3USB221RSER	UQFN	RSE	10	3000	180.0	9.5	1.7	2.2	0.75	4.0	8.0	Q1

TAPE AND REEL BOX DIMENSIONS

*All dimensions are nominal

Device	Package Type	Package Drawing	Pins	SPQ	Length (mm)	Width (mm)	Height (mm)
TS3USB221DRCR	VSON	DRC	10	3000	370.0	355.0	55.0
TS3USB221RSER	UQFN	RSE	10	3000	202.0	201.0	28.0
TS3USB221RSER	UQFN	RSE	10	3000	184.0	184.0	19.0
TS3USB221RSER	UQFN	RSE	10	3000	189.0	185.0	36.0

DRC (S-PVSON-N10)

PLASTIC SMALL OUTLINE NO-LEAD



- NOTES:
- All linear dimensions are in millimeters. Dimensioning and tolerancing per ASME Y14.5M-1994.
 - This drawing is subject to change without notice.
 - Small Outline No-Lead (SON) package configuration.
 - The package thermal pad must be soldered to the board for thermal and mechanical performance, if present.
 - See the additional figure in the Product Data Sheet for details regarding the exposed thermal pad features and dimensions, if present

THERMAL PAD MECHANICAL DATA

DRC (S-PVSON-N10)

PLASTIC SMALL OUTLINE NO-LEAD

THERMAL INFORMATION

This package incorporates an exposed thermal pad that is designed to be attached directly to an external heatsink. The thermal pad must be soldered directly to the printed circuit board (PCB). After soldering, the PCB can be used as a heatsink. In addition, through the use of thermal vias, the thermal pad can be attached directly to the appropriate copper plane shown in the electrical schematic for the device, or alternatively, can be attached to a special heatsink structure designed into the PCB. This design optimizes the heat transfer from the integrated circuit (IC).

For information on the Quad Flatpack No-Lead (QFN) package and its advantages, refer to Application Report, QFN/SON PCB Attachment, Texas Instruments Literature No. SLUA271. This document is available at www.ti.com.

The exposed thermal pad dimensions for this package are shown in the following illustration.

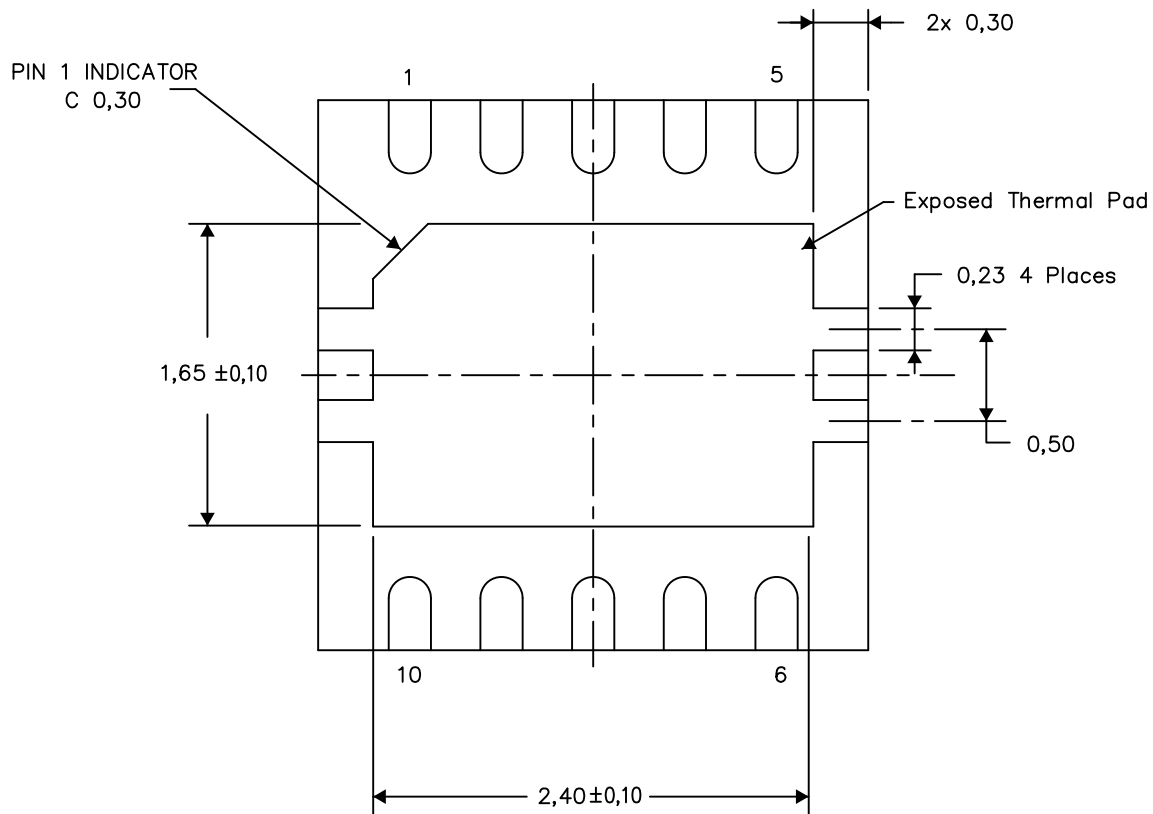

Bottom View

Exposed Thermal Pad Dimensions

4206565-3/Y 08/15

NOTE: A. All linear dimensions are in millimeters

DRC (S-PVSON-N10)

PLASTIC SMALL OUTLINE NO-LEAD

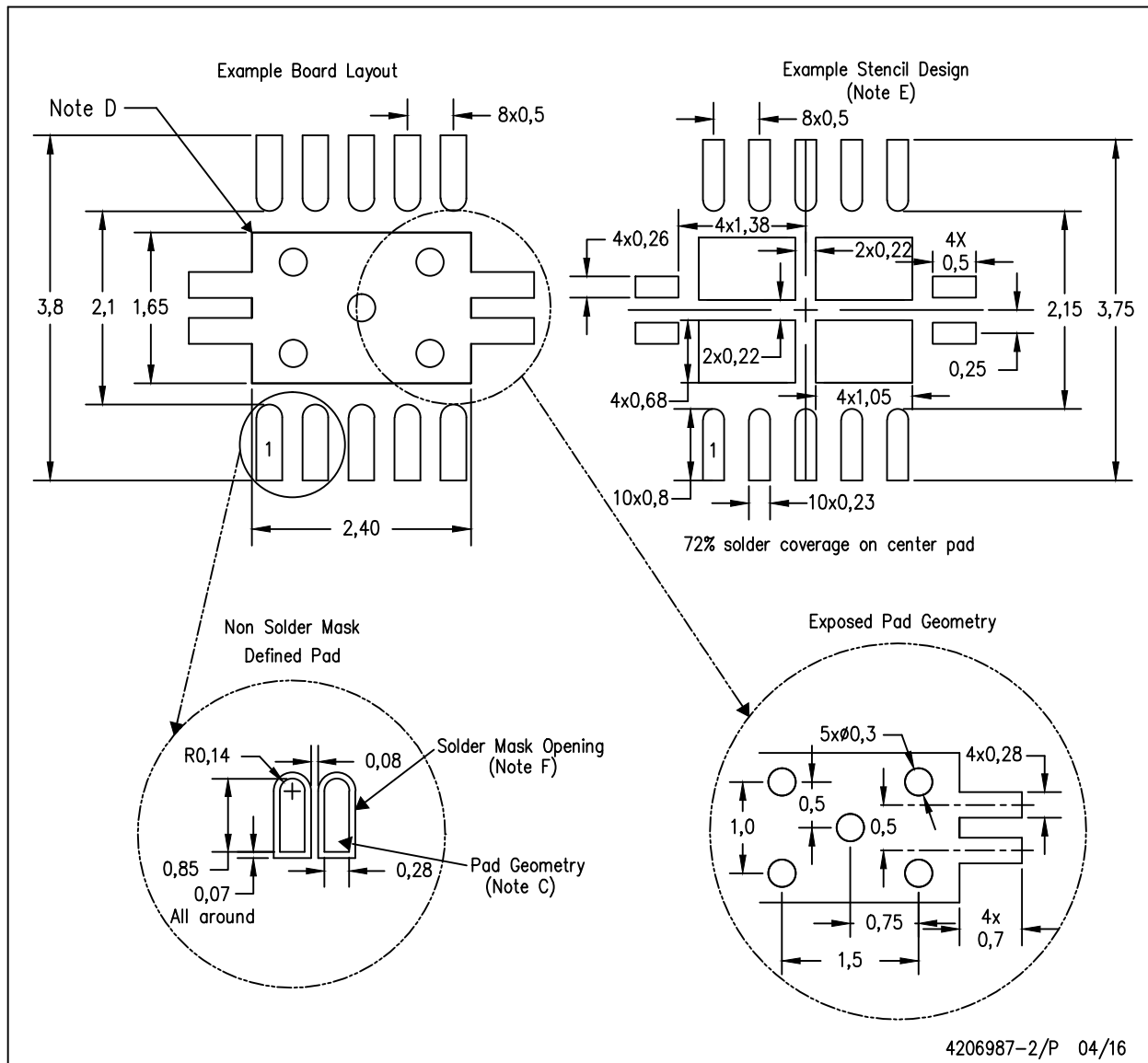

- NOTES:
- All linear dimensions are in millimeters.
 - This drawing is subject to change without notice.
 - Publication IPC-7351 is recommended for alternate designs.
 - This package is designed to be soldered to a thermal pad on the board. Refer to Application Note, Quad Flat-Pack Packages, Texas Instruments Literature No. SLUA271, and also the Product Data Sheets for specific thermal information, via requirements, and recommended board layout. These documents are available at www.ti.com <<http://www.ti.com>>.
 - Laser cutting apertures with trapezoidal walls and also rounding corners will offer better paste release. Customers should contact their board assembly site for stencil design recommendations. Refer to IPC 7525 for stencil design considerations.
 - Customers should contact their board fabrication site for minimum solder mask web tolerances between signal pads.

RSE (R-PUQFN-N10)

PLASTIC QUAD FLATPACK NO-LEAD

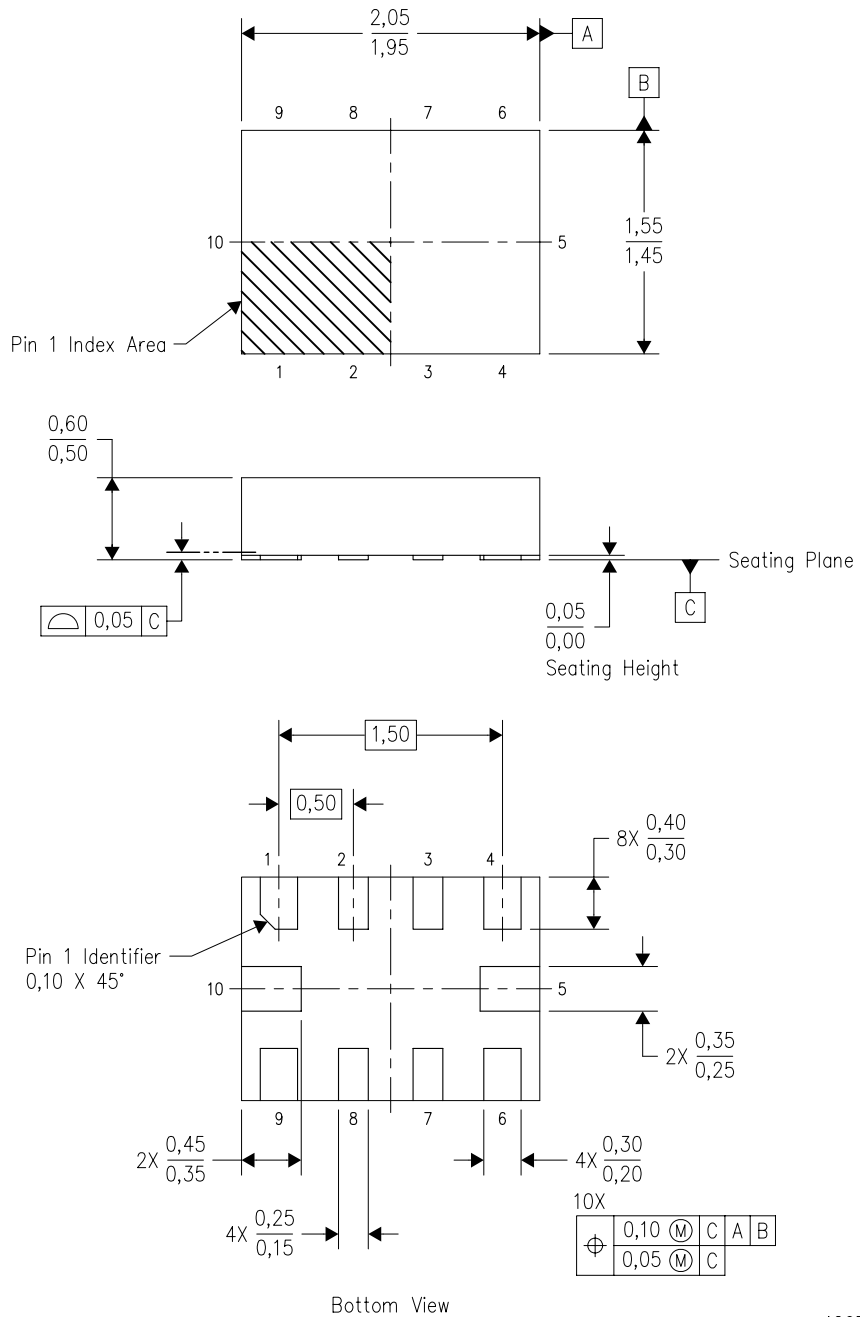

4207268-3/D 01/11

- NOTES:
- A. All linear dimensions are in millimeters. Dimensioning and tolerancing per ASME Y14.5M-1994.
 - B. This drawing is subject to change without notice.
 - C. QFN (Quad Flatpack No-Lead) package configuration.
 - D. This package complies to JEDEC MO-288 variation UDFD.

RSE (R-PUQFN-N10)

PLASTIC QUAD FLATPACK NO-LEAD

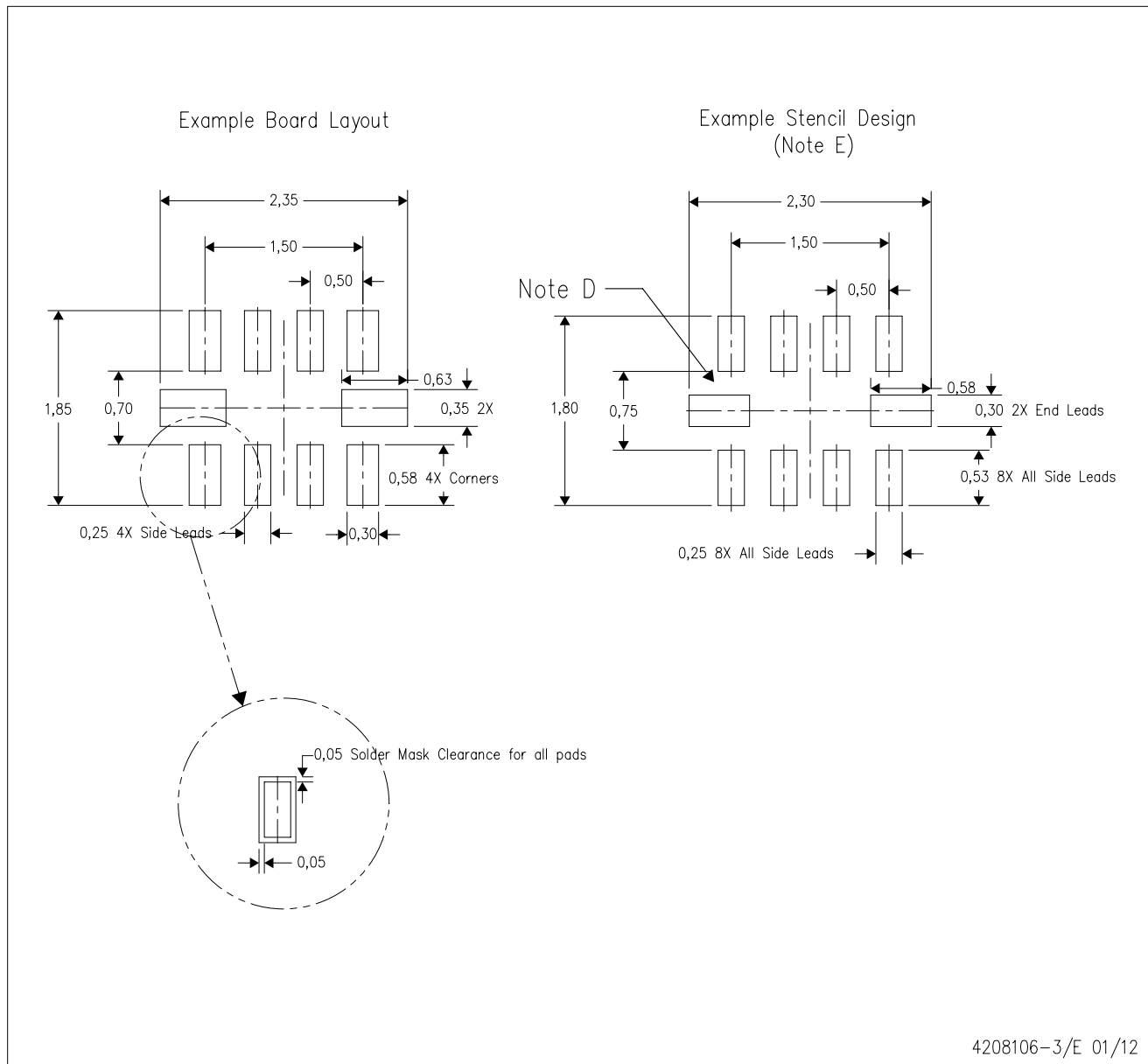

- NOTES:
- A. All linear dimensions are in millimeters.
 - B. This drawing is subject to change without notice.
 - C. Publication IPC-7351 is recommended for alternate designs.
 - D. Customers should contact their board fabrication site for minimum solder mask web tolerances between signal pads.
 - E. Maximum stencil thickness 0,127 mm (5 mils). All linear dimensions are in millimeters.
 - F. Laser cutting apertures with trapezoidal walls and also rounding corners will offer better paste release. Customers should contact their board assembly site for stencil design recommendations. Refer to IPC 7525 for stencil design considerations.
 - G. Side aperture dimensions over-print land for acceptable area ratio > 0.66. Customer may reduce side aperture dimensions if stencil manufacturing process allows for sufficient release at smaller opening.

IMPORTANT NOTICE

Texas Instruments Incorporated (TI) reserves the right to make corrections, enhancements, improvements and other changes to its semiconductor products and services per JESD46, latest issue, and to discontinue any product or service per JESD48, latest issue. Buyers should obtain the latest relevant information before placing orders and should verify that such information is current and complete.

TI's published terms of sale for semiconductor products (<http://www.ti.com/sc/docs/stdterms.htm>) apply to the sale of packaged integrated circuit products that TI has qualified and released to market. Additional terms may apply to the use or sale of other types of TI products and services.

Reproduction of significant portions of TI information in TI data sheets is permissible only if reproduction is without alteration and is accompanied by all associated warranties, conditions, limitations, and notices. TI is not responsible or liable for such reproduced documentation. Information of third parties may be subject to additional restrictions. Resale of TI products or services with statements different from or beyond the parameters stated by TI for that product or service voids all express and any implied warranties for the associated TI product or service and is an unfair and deceptive business practice. TI is not responsible or liable for any such statements.

Buyers and others who are developing systems that incorporate TI products (collectively, "Designers") understand and agree that Designers remain responsible for using their independent analysis, evaluation and judgment in designing their applications and that Designers have full and exclusive responsibility to assure the safety of Designers' applications and compliance of their applications (and of all TI products used in or for Designers' applications) with all applicable regulations, laws and other applicable requirements. Designer represents that, with respect to their applications, Designer has all the necessary expertise to create and implement safeguards that (1) anticipate dangerous consequences of failures, (2) monitor failures and their consequences, and (3) lessen the likelihood of failures that might cause harm and take appropriate actions. Designer agrees that prior to using or distributing any applications that include TI products, Designer will thoroughly test such applications and the functionality of such TI products as used in such applications.

TI's provision of technical, application or other design advice, quality characterization, reliability data or other services or information, including, but not limited to, reference designs and materials relating to evaluation modules, (collectively, "TI Resources") are intended to assist designers who are developing applications that incorporate TI products; by downloading, accessing or using TI Resources in any way, Designer (individually or, if Designer is acting on behalf of a company, Designer's company) agrees to use any particular TI Resource solely for this purpose and subject to the terms of this Notice.

TI's provision of TI Resources does not expand or otherwise alter TI's applicable published warranties or warranty disclaimers for TI products, and no additional obligations or liabilities arise from TI providing such TI Resources. TI reserves the right to make corrections, enhancements, improvements and other changes to its TI Resources. TI has not conducted any testing other than that specifically described in the published documentation for a particular TI Resource.

Designer is authorized to use, copy and modify any individual TI Resource only in connection with the development of applications that include the TI product(s) identified in such TI Resource. NO OTHER LICENSE, EXPRESS OR IMPLIED, BY ESTOPPEL OR OTHERWISE TO ANY OTHER TI INTELLECTUAL PROPERTY RIGHT, AND NO LICENSE TO ANY TECHNOLOGY OR INTELLECTUAL PROPERTY RIGHT OF TI OR ANY THIRD PARTY IS GRANTED HEREIN, including but not limited to any patent right, copyright, mask work right, or other intellectual property right relating to any combination, machine, or process in which TI products or services are used. Information regarding or referencing third-party products or services does not constitute a license to use such products or services, or a warranty or endorsement thereof. Use of TI Resources may require a license from a third party under the patents or other intellectual property of the third party, or a license from TI under the patents or other intellectual property of TI.

TI RESOURCES ARE PROVIDED "AS IS" AND WITH ALL FAULTS. TI DISCLAIMS ALL OTHER WARRANTIES OR REPRESENTATIONS, EXPRESS OR IMPLIED, REGARDING RESOURCES OR USE THEREOF, INCLUDING BUT NOT LIMITED TO ACCURACY OR COMPLETENESS, TITLE, ANY EPIDEMIC FAILURE WARRANTY AND ANY IMPLIED WARRANTIES OF MERCHANTABILITY, FITNESS FOR A PARTICULAR PURPOSE, AND NON-INFRINGEMENT OF ANY THIRD PARTY INTELLECTUAL PROPERTY RIGHTS. TI SHALL NOT BE LIABLE FOR AND SHALL NOT DEFEND OR INDEMNIFY DESIGNER AGAINST ANY CLAIM, INCLUDING BUT NOT LIMITED TO ANY INFRINGEMENT CLAIM THAT RELATES TO OR IS BASED ON ANY COMBINATION OF PRODUCTS EVEN IF DESCRIBED IN TI RESOURCES OR OTHERWISE. IN NO EVENT SHALL TI BE LIABLE FOR ANY ACTUAL, DIRECT, SPECIAL, COLLATERAL, INDIRECT, PUNITIVE, INCIDENTAL, CONSEQUENTIAL OR EXEMPLARY DAMAGES IN CONNECTION WITH OR ARISING OUT OF TI RESOURCES OR USE THEREOF, AND REGARDLESS OF WHETHER TI HAS BEEN ADVISED OF THE POSSIBILITY OF SUCH DAMAGES.

Unless TI has explicitly designated an individual product as meeting the requirements of a particular industry standard (e.g., ISO/TS 16949 and ISO 26262), TI is not responsible for any failure to meet such industry standard requirements.

Where TI specifically promotes products as facilitating functional safety or as compliant with industry functional safety standards, such products are intended to help enable customers to design and create their own applications that meet applicable functional safety standards and requirements. Using products in an application does not by itself establish any safety features in the application. Designers must ensure compliance with safety-related requirements and standards applicable to their applications. Designer may not use any TI products in life-critical medical equipment unless authorized officers of the parties have executed a special contract specifically governing such use. Life-critical medical equipment is medical equipment where failure of such equipment would cause serious bodily injury or death (e.g., life support, pacemakers, defibrillators, heart pumps, neurostimulators, and implantables). Such equipment includes, without limitation, all medical devices identified by the U.S. Food and Drug Administration as Class III devices and equivalent classifications outside the U.S.

TI may expressly designate certain products as completing a particular qualification (e.g., Q100, Military Grade, or Enhanced Product). Designers agree that it has the necessary expertise to select the product with the appropriate qualification designation for their applications and that proper product selection is at Designers' own risk. Designers are solely responsible for compliance with all legal and regulatory requirements in connection with such selection.

Designer will fully indemnify TI and its representatives against any damages, costs, losses, and/or liabilities arising out of Designer's non-compliance with the terms and provisions of this Notice.