

PROGRAMMABLE SHUNT VOLTAGE REFERENCE

- ADJUSTABLE OUTPUT VOLTAGE
2.5 to 24V
- SEVERAL PRECISION @ 25°C
±2%, ±1% and ±0.5%
- SINK CURRENT CAPABILITY
1 to 100mA
- INDUSTRIAL TEMPERATURE RANGE:
-40 to +105°C
- PERFORMANCES COMPATIBLE WITH
INDUSTRY STANDARD TL431

DESCRIPTION

The TS2431 is a programmable shunt voltage reference with guaranteed temperature stability over the entire temperature range of operation (-40 to +105°C). The output voltage may be set to any value between 2.5V and 24V with an external resistor bridge.

Available in SOT23-3 surface mount package, it can be designed in applications where space saving is a critical issue.

APPLICATION

- Computers
- Instrumentation
- Battery chargers
- Switch Mode Power Supply
- Battery operated equipments

ORDER CODE

Precision	Part Number in SOT23-3	SOT23 Marking
2%	TS2431ILT	L285
1%	TS2431AILT	L286
0.5%	TS2431BILT	L287
Single temperature range: -40 to +105°C		

LT = Tiny Package (SOT23-3) - only available in Tape & Reel (LT)

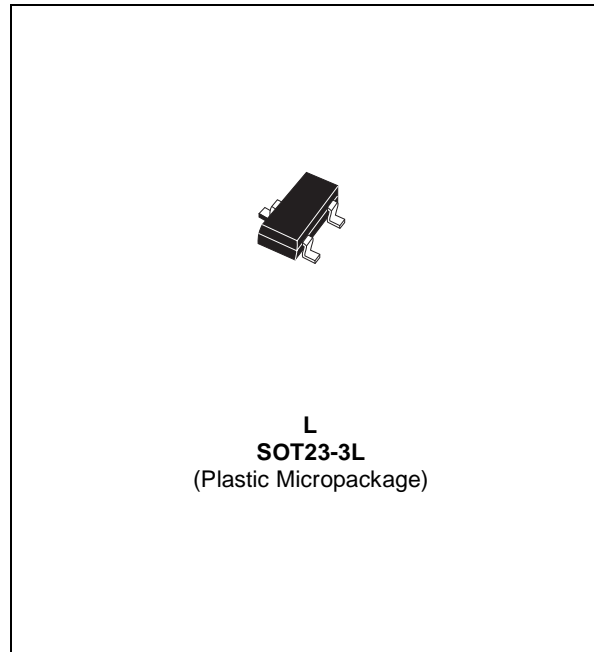

PIN CONNECTIONS (top view)

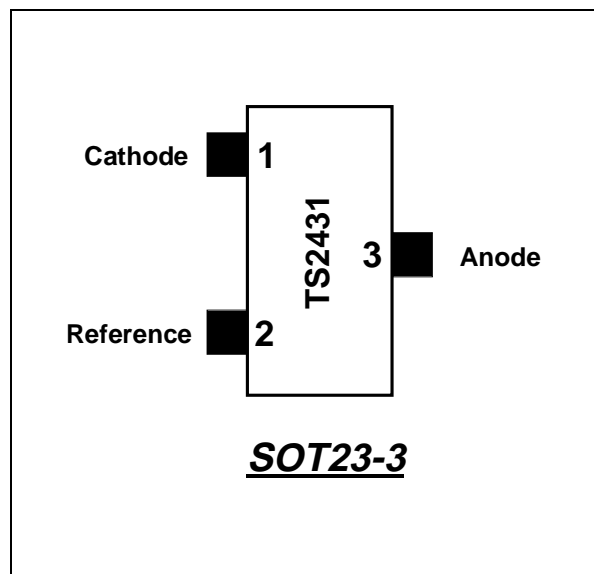

ABSOLUTE MAXIMUM RATINGS

Symbol	Parameter	Value	Unit
V _{ka}	Cathode to Anode voltage	25	V
I _K	Reverse Breakdown Current	-100 to +150	mA
I _{REF}	Reference input current range	-0.05 to +10	mA
P _d	Power Dissipation ¹⁾ SOT23-3	360	mW
T _{std}	Storage Temperature	-65 to +150	°C
ESD	Human Body Model (HBM)	2	kV
	Machine Model (MM)	200	V
T _{LEAD}	Lead Temperature (soldering, 10 seconds)	260	°C

1. P_d has been calculated with T_{amb} = 25°C, T_{junction} = 150°C and R_{thja} = 340°C/W for the SOT23-3 package

OPERATING CONDITIONS

Symbol	Parameter	Value	Unit
V _{KA}	Cathode to Anode voltage	V _{REF} to 24	V
I _K	Cathode operating current ¹⁾	1 to 100	mA
T _{oper}	Operating Free Air Temperature Range	-40 to +105	°C

1. Maximum power dissipation must be strictly observed to avoid the component destruction.

ELECTRICAL CHARACTERISTICS

T_{AMBIENT} = 25°C (unless otherwise specified)

Symbol	Parameter	Test Condition	Min.	Typ.	Max.	Unit
V _{REF}	Reference input Voltage	V _K =V _{REF} , I _K =10mA		2.5		V
		TS2431 (2%)	2.45		2.55	
		TS2431A (1%)	2.475		2.525	
		TS2431B (0.5%)	2.488		2.512	
ΔV _{REF}	Reference input Voltage deviation over temperature, V _K =V _{REF} , I _K =10mA (note 1,2)	0°C < T < +70°C		10	20	mV
		-40°C < T < +85°C		17	30	
		-40°C < T < +105°C		20	35	
T _C	Temperature coefficient (note 2)	-40°C < T < +105°C		50	100	ppm/°C
I _{KMIN}	Minimum Operating Current	T = 25°C		0.3	0.8	mA
		-40°C < T < +105°C			1	
$\left \frac{\Delta V_{ref}}{\Delta V_k} \right $	Ratio of change in reference input voltage to change in cathode to anode voltage	I _K =10mA V _{ka} = 24 to 2.5V		0.3	2	mV/V
I _{REF}	Reference input current I _K =10mA, R1=10KΩ, R2=+∞ (note 3)	T=25°C		0.5	2.5	μA
		-40°C < T < +105°C			3	
ΔI _{REF}	Reference input current deviation I _K =10mA, R1=10KΩ, R2=+∞ (note 3)	-40°C < T < +105°C		0.4	1.2	μA
I _{OFF}	Off-state cathode current	V _K =24V, V _{REF} =GND		10	500	nA
Z _{KA}	Reverse dynamic impedance	V _K =V _{REF} ΔI _K =1 to 50mA, f<10kHz		0.5	0.75	Ω
E _N	Wide Band Noise	I _k = 10mA 10Hz < f < 10kHz		300		nV/√Hz

Note 1: Limits are 100% production tested at 25°C. Limits over temperature are guaranteed through correlation and by design.

Note 2: |ΔV_{REF}| is defined as the difference between the maximum and minimum values of V_{REF} obtained over the full temperature range

Note 3: Refer to figure "Test circuit for V_{ka}>V_{ref}" page 4

Reference voltage vs temperature

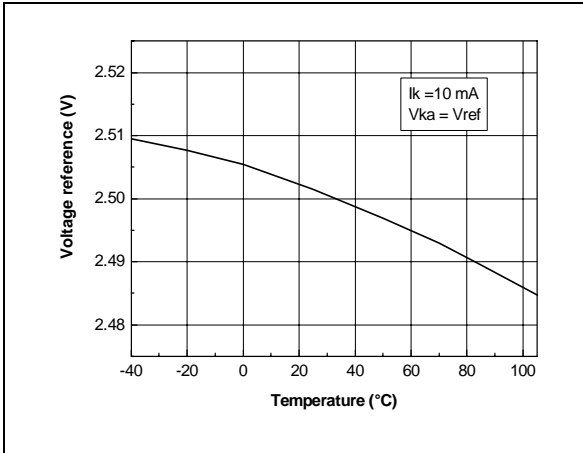

Test circuit for $V_{ka} = V_{ref}$

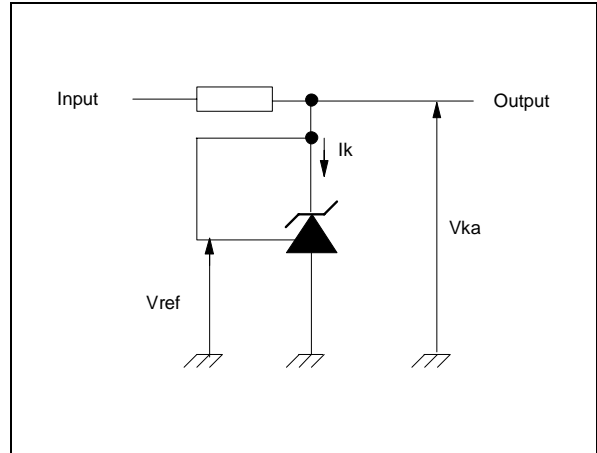

Cathode voltage vs cathode current

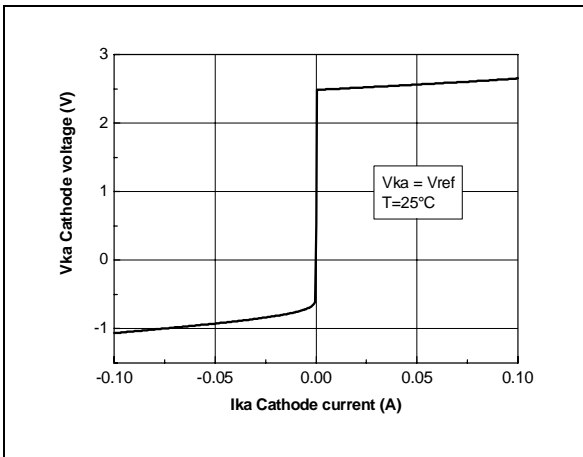

Cathode voltage vs cathode current

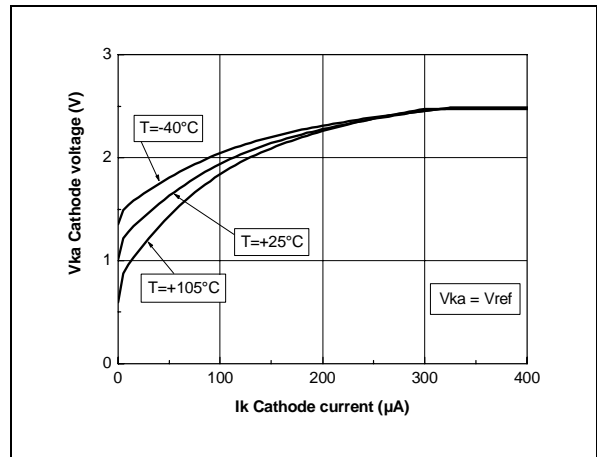

Reference input current vs temperature

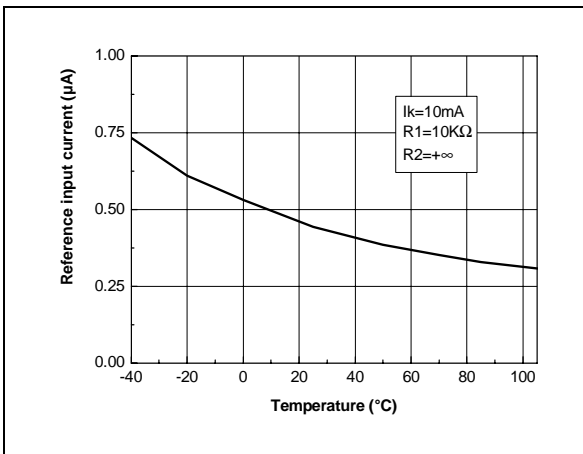

Dynamic impedance vs frequency

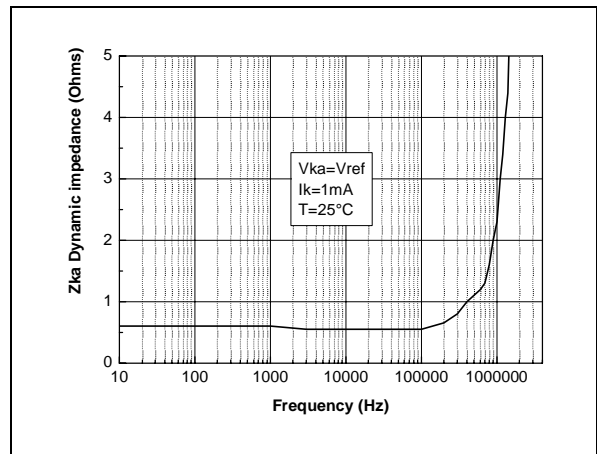

Off-State current vs temperature

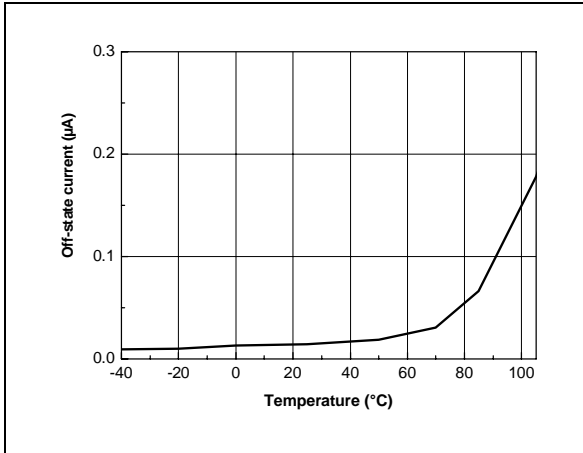

Test circuit for Off-State current measurement

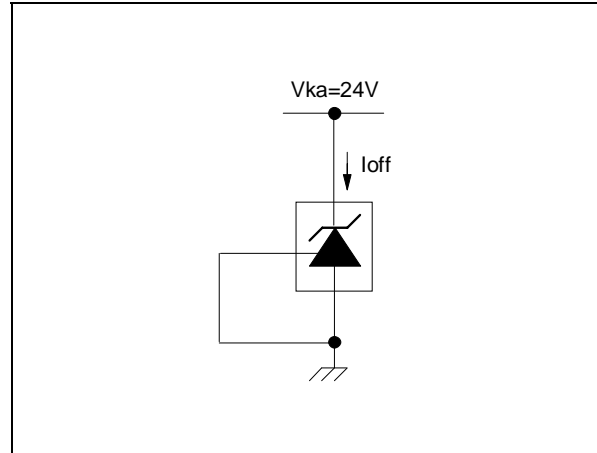

Ratio of change in reference input voltage to change in Vka voltage vs temperature

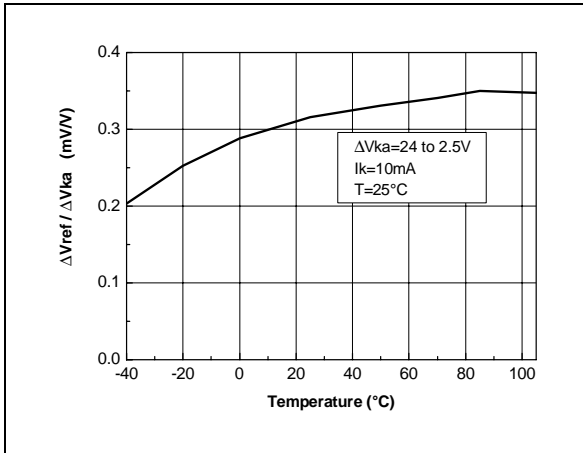

Test circuit for Vka > Vref

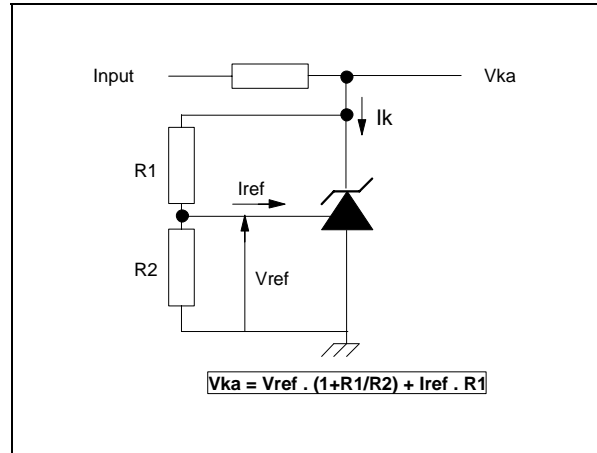

Phase and Gain vs frequency

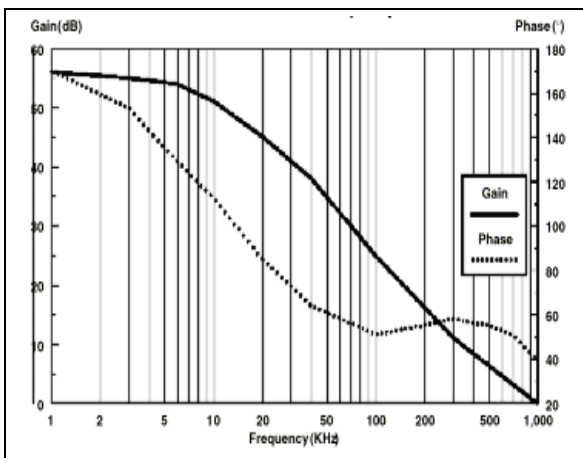

Test circuit for phase and gain measurement

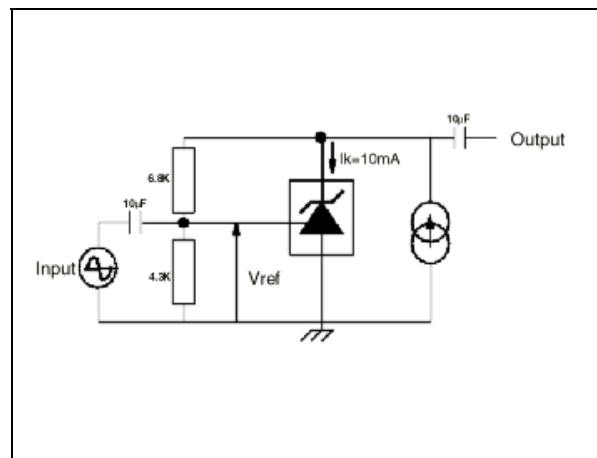

Pulse response at $I_k=1\text{mA}$

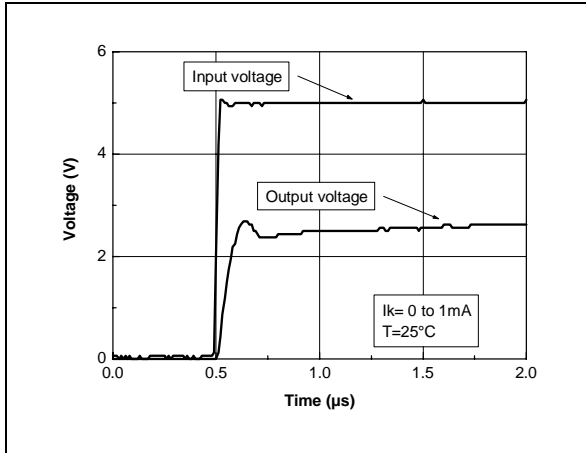

Test circuit for pulse response at $I_k = 1\text{mA}$

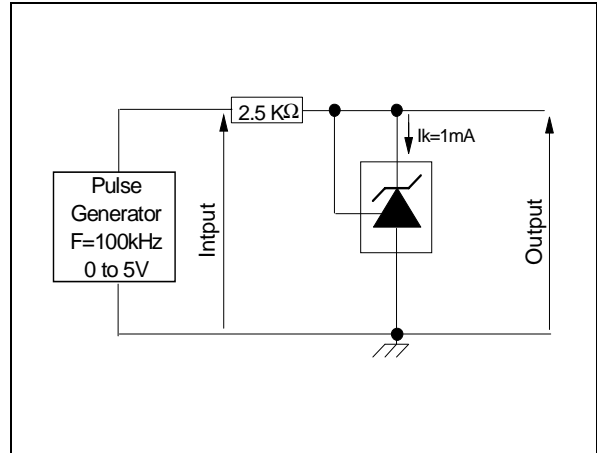

Pulse response at $I_k = 1\text{mA}$

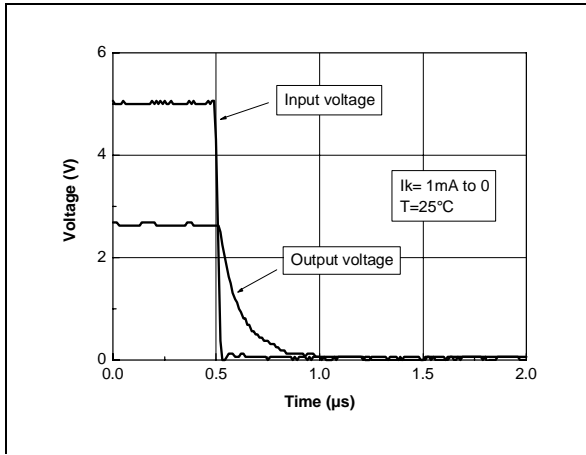

Equivalent input noise vs frequency

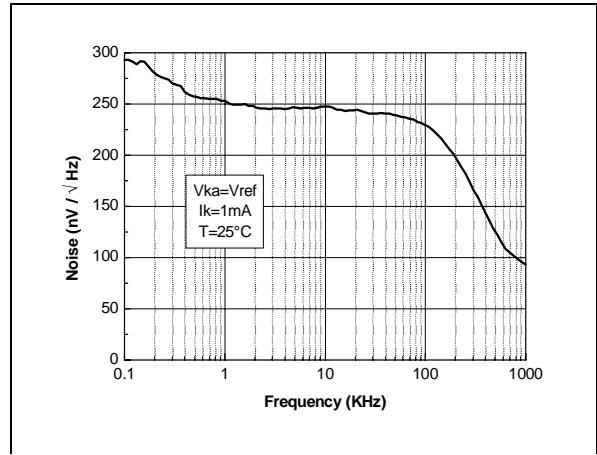

Stability boundary conditions

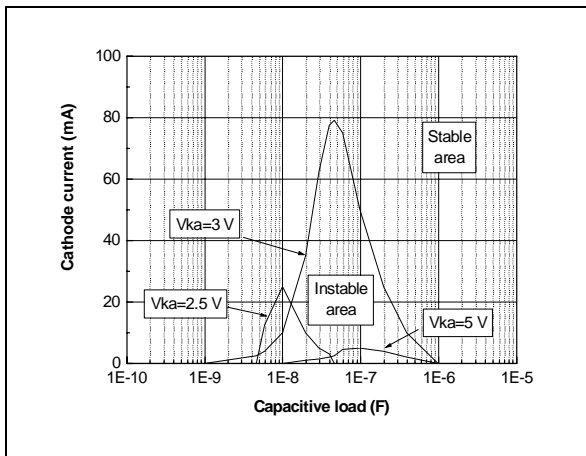

Block Diagram

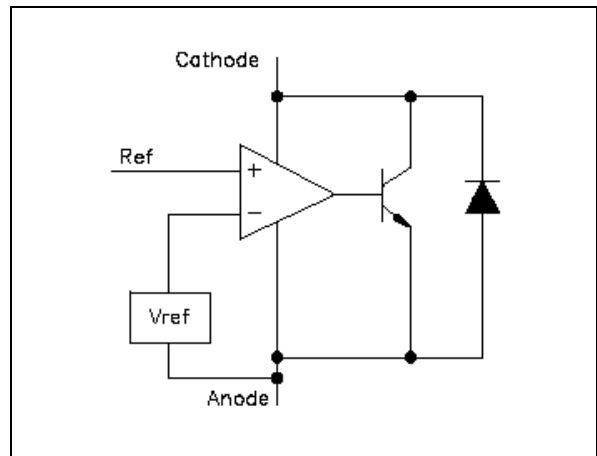

PACKAGE MECHANICAL DATA
3 PINS - TINY PACKAGE (SOT-23)

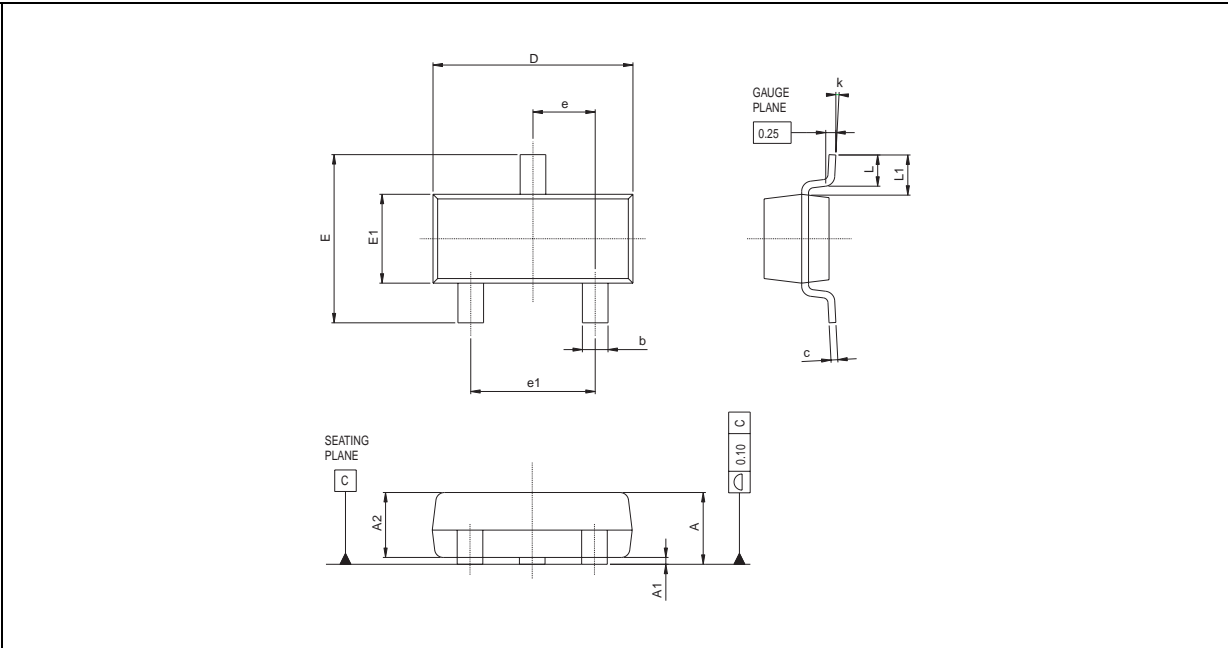

Dimensions	Millimeters			Inches		
	Min.	Typ.	Max.	Min.	Typ.	Max.
A	0.890		1.120	0.035		0.044
A1	0.010		0.100	0.0004		0.004
A2	0.880	0.950	1.020		0.037	0.040
b	0.300		0.500	0.012		0.020
c	0.080		0.200	0.003		0.008
D	2.800	2.900	3.040	0.110	0.114	0.120
E	2.100		2.640	0.083		0.104
E1	1.200	1.300	1.400	0.047	0.051	0.055
e		0.950			0.037	
e1		1.900			0.075	
L	0.400	0.500	0.600	0.016	0.020	0.024
L1		0.540			0.021	
k	0°		8°			

Information furnished is believed to be accurate and reliable. However, STMicroelectronics assumes no responsibility for the consequences of use of such information nor for any infringement of patents or other rights of third parties which may result from its use. No license is granted by implication or otherwise under any patent or patent rights of STMicroelectronics. Specifications mentioned in this publication are subject to change without notice. This publication supersedes and replaces all information previously supplied. STMicroelectronics products are not authorized for use as critical components in life support devices or systems without express written approval of STMicroelectronics.

© The ST logo is a registered trademark of STMicroelectronics

© 2002 STMicroelectronics - Printed in Italy - All Rights Reserved
STMicroelectronics GROUP OF COMPANIES

Australia - Brazil - Canada - China - Finland - France - Germany - Hong Kong - India - Israel - Italy - Japan - Malaysia - Malta
 Morocco - Singapore - Spain - Sweden - Switzerland - United Kingdom - United States

© <http://www.st.com>