

DUAL SUPPLY, LOW ON-STATE RESISTANCE SPST CMOS ANALOG SWITCHES

FEATURES

- ± 1 -V to ± 6 -V Dual-Supply Operation
- Specified ON-State Resistance:
 - 25 Ω Max With ± 5 -V Supply
 - 35 Ω Max With ± 3.3 -V Supply
 - 47 Ω Max With ± 1.8 -V Supply
- Specified Low OFF-Leakage Currents:
 - 5 nA at 25°C
 - 10 nA at 85°C
- Specified Low ON-Leakage Currents:
 - 5 nA at 25°C
 - 10 nA at 85°C
- Low Charge Injection: 13 pC (± 5 -V Supply)
- Fast Switching Speed:
 - $t_{ON} = 85$ ns, $t_{OFF} = 50$ ns (± 5 -V Supply)
- Break-Before-Make Operation ($t_{ON} > t_{OFF}$)
- Latch-Up Performance Exceeds 100 mA Per JESD 78, Class II
- ESD Performance Tested Per JESD 22
 - 2500-V Human-Body Model (A114-F)
 - 1000-V Charged-Device Model (C101-C)
 - 250-V Machine Model (A115-A)

DESCRIPTION/ORDERING INFORMATION

The TS12A4516/TS12A4517 are single pole/single throw (SPST), low-voltage, dual-supply CMOS analog switches, with very low switch ON-state resistance. The TS12A4516 is normally open (NO). The TS12A4517 is normally closed (NC).

These CMOS switches can operate continuously with a dual supplies between ± 1 V and ± 6 V [2 V $< (V_+ - V_-) < 12$ V]. Each switch can handle rail-to-rail analog signals. The OFF-leakage current maximum is only 5 nA at 25°C or 10 nA at 85°C.

For pin-compatible parts for use with single supply, see the TS12A4514/TS12A4515.

ORDERING INFORMATION

T_A	PACKAGE ⁽¹⁾⁽²⁾		ORDERABLE PART NUMBER	TOP-SIDE MARKING
–40°C to 85°C	SOIC – D	Reel of 1500	TS12A4516D	YD516
		Reel of 2500	TS12A4516DR	
	SOP (SOT-23) – DBV	Reel of 3000	TS12A4516DBVR	9CL_
	SOIC – D	Reel of 1500	TS12A4517D	YD517
		Reel of 2500	TS12A4517DR	
	SOP (SOT-23) – DBV	Reel of 3000	TS12A4517DBVR	9CM_

(1) Package drawings, standard packing quantities, thermal data, symbolization, and PCB design guidelines are available at www.ti.com/sc/package.

(2) For the most current package and ordering information, see the Package Option Addendum at the end of this document, or see the TI website at www.ti.com.



Please be aware that an important notice concerning availability, standard warranty, and use in critical applications of Texas Instruments semiconductor products and disclaimers thereto appears at the end of this data sheet.

PIN CONFIGURATIONS

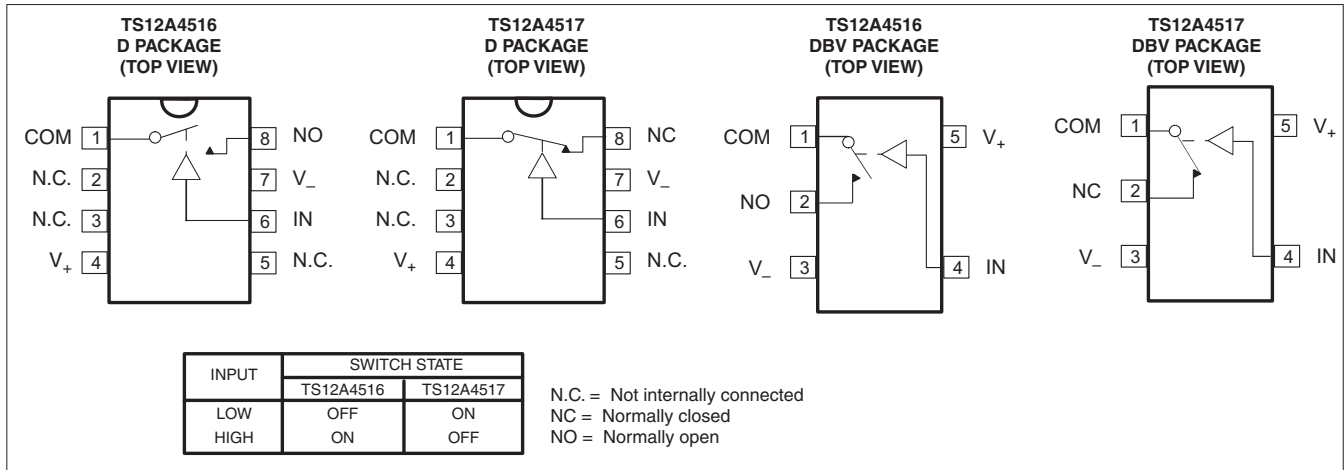

Absolute Minimum and Maximum Ratings⁽¹⁾⁽²⁾

voltages referenced to 0 V

		MIN	MAX	UNIT
V_+	Supply voltage range	-0.3	13	V
V_{NC} V_{NO} V_{COM}	Analog voltage range ⁽³⁾	$V_- - 0.3$	$V_+ + 0.3$	V
V_{IN}	Logic input range	$V_- - 0.3$	$V_+ + 0.3$	V
	Continuous current into any terminal		±20	mA
	Peak current, NO or COM (pulsed at 1 ms, 10% duty cycle)		±30	mA
	ESD per method 3015.7		>2000	V
	Continuous power dissipation ($T_A = 70^\circ\text{C}$)	8-pin SOIC (derate 5.88 mW/°C above 70°C)		471
		5-pin SOT23-5 (derate 7.1 mW/°C above 70°C)		571
T_A	Operating temperature range	-40	85	°C
T_{stg}	Storage temperature range	-65	150	°C
	Lead temperature (soldering, 10 s)		300	°C

- (1) Stresses beyond those listed under "absolute maximum ratings" may cause permanent damage to the device. These are stress ratings only, and functional operation of the device at these or any other conditions beyond those indicated under "recommended operating conditions" is not implied. Exposure to absolute-maximum-rated conditions for extended periods may affect device reliability.
- (2) The algebraic convention, whereby the most negative value is a minimum and the most positive value is a maximum
- (3) Voltages exceeding V_+ or GND on any signal terminal are clamped by internal diodes. Limit forward-diode current to maximum current rating.

Electrical Characteristics for ±5-V Supply⁽¹⁾
 $V_+ = 4.5\text{ V to }5.5\text{ V}$, $V_- = -4.5\text{ V to }-5.5\text{ V}$, $T_A = -40^\circ\text{C to }85^\circ\text{C}$ (unless otherwise noted)

PARAMETER	SYMBOL	TEST CONDITIONS	T_A	MIN	TYP ⁽²⁾	MAX	UNIT
Analog Switch							
Analog signal range	V_{COM}, V_{NO}, V_{NC}			V_-		V_+	V
ON-state resistance	r_{on}	$V_+ = 4.5\text{ V}, V_- = -4.5\text{ V},$ $V_{COM} = 3.5\text{ V},$ $I_{COM} = 20\text{ mA}$	25°C		12	20	Ω
			Full			25	
ON-state resistance flatness	$r_{on(Flat)}$	$V_+ = 4.5\text{ V}, V_- = -4.5\text{ V},$ $V_{COM} = -3.5\text{ V}, 0\text{ V}, 3.5\text{ V},$ $I_{COM} = 20\text{ mA}$	25°C		1.2	2.5	Ω
			Full			3	
NO, NC OFF leakage current ⁽³⁾	$I_{NO(OFF)},$ $I_{NC(OFF)}$	$V_+ = 5.5\text{ V}, V_- = -5.5\text{ V},$ $V_{COM} = 4.5\text{ V},$ $V_{NO}\text{ or }V_{NC} = -4.5\text{ V}$	25°C			5	nA
			Full			10	
COM OFF leakage current ⁽³⁾	$I_{COM(OFF)}$	$V_+ = 5.5\text{ V}, V_- = -5.5\text{ V},$ $V_{COM} = -4.5\text{ V},$ $V_{NO}\text{ or }V_{NC} = 4.5\text{ V}$	25°C			5	nA
			Full			10	
COM ON leakage current ⁽³⁾	$I_{COM(ON)}$	$V_+ = 5.5\text{ V}, V_- = -5.5\text{ V},$ $V_{COM} = 5.5\text{ V},$ $V_{NO}\text{ or }V_{NC} = \text{open}$	25°C			5	nA
			Full			10	
Digital Control Input (IN)							
Input logic high	V_{IH}		Full	$V_+ - 1.5$			V
Input logic low	V_{IL}		Full	V_-		$V_+ - 3.5$	V
Input leakage current	I_{IH}, I_{IL}	$V_{IN} = V_+, 0\text{ V}$	Full			0.010	μA
Dynamic							
Turn-on time	t_{ON}	See Figure 2	25°C		58	75	ns
			Full			85	
Turn-off time	t_{OFF}	See Figure 2	25°C		28	45	ns
			Full			50	
Charge injection ⁽⁴⁾	Q_C	$C_L = 1\text{ nF}, V_{NO} = 0\text{ V},$ $R_S = 0\text{ Ω},$ See Figure 1	25°C		-13		pC
NO, NC OFF capacitance	$C_{NO(OFF)},$ $C_{NC(OFF)}$	$f = 1\text{ MHz},$ See Figure 4	25°C		5.5		pF
COM OFF capacitance	$C_{COM(OFF)}$	$f = 1\text{ MHz},$ See Figure 4	25°C		5.5		pF
COM ON capacitance	$C_{COM(ON)}$	$f = 1\text{ MHz},$ See Figure 4	25°C		16		pF
Digital input capacitance	C_I	$V_{IN} = V_+, 0\text{ V}$	25°C		1.5		pF
Bandwidth	BW	$R_L = 50\text{ Ω}, C_L = 15\text{ pF},$ $V_{NO} = 1\text{ V}_{RMS}, f = 100\text{ kHz}$	25°C		464		MHz
OFF isolation	O_{ISO}	$R_L = 50\text{ Ω}, C_L = 15\text{ pF},$ $V_{NO} = 1\text{ V}_{RMS}, f = 1\text{ MHz}$	25°C		-83		dB
Total harmonic distortion	THD	$R_L = 600\text{ Ω}, C_L = 15\text{ pF},$ $V_{NO} = 1\text{ V}_{RMS}, f = 20\text{ kHz}$	25°C		0.07		%
Supply							
V_+ supply current	I_+	$V_{IN} = 0\text{ V or }V_+$	25°C			70	μA
			Full			80	
V_- supply current	I_-	$V_{IN} = 0\text{ V or }V_+$	25°C		-70		μA
			Full		-80		

- (1) The algebraic convention, whereby the most negative value is a minimum and the most positive value is a maximum.
 (2) Typical values are at $T_A = 25^\circ\text{C}$.
 (3) Leakage parameters are 100% tested at maximum-rated hot operating temperature, and are ensured by correlation at 25°C .
 (4) Specified by design, not production tested

Electrical Characteristics for $\pm 3.3\text{-V}$ Supply⁽¹⁾

$V_+ = 3.0\text{ V}$ to 3.6 V , $V_- = -3.0\text{ V}$ to -3.6 V , $T_A = -40^\circ\text{C}$ to 85°C (unless otherwise noted)

PARAMETER	SYMBOL	TEST CONDITIONS	T_A	MIN	TYP ⁽²⁾	MAX	UNIT
Analog Switch							
Analog signal range	$V_{\text{COM}}, V_{\text{NO}}, V_{\text{NC}}$			V_-		V_+	V
ON-state resistance	r_{on}	$V_+ = 3.0\text{ V}, V_- = -3.0\text{ V},$ $V_{\text{COM}} = 3\text{ V},$ $I_{\text{COM}} = 20\text{ mA}$	25°C		17	25	Ω
			Full			35	
ON-state resistance flatness	$r_{\text{on(flat)}}$	$V_{\text{COM}} = -2\text{ V}, 0\text{ V}, 2\text{ V},$ $I_{\text{COM}} = 20\text{ mA}$	25°C		1.5	3	Ω
			Full			4	
NO, NC OFF leakage current ⁽³⁾	$I_{\text{NO(OFF)}},$ $I_{\text{NC(OFF)}}$	$V_+ = 3.6\text{ V}, V_- = -3.6\text{ V},$ $V_{\text{COM}} = 3\text{ V},$ V_{NO} or $V_{\text{NC}} = -3\text{ V}$	25°C			5	nA
			Full			10	
COM OFF leakage current ⁽³⁾	$I_{\text{COM(OFF)}}$	$V_+ = 3.6\text{ V}, V_- = -3.6\text{ V},$ $V_{\text{COM}} = -3\text{ V},$ V_{NO} or $V_{\text{NC}} = 3\text{ V}$	25°C			5	nA
			Full			10	
COM ON leakage current ⁽³⁾	$I_{\text{COM(ON)}}$	$V_+ = 3.6\text{ V}, V_- = -3.6\text{ V},$ $V_{\text{COM}} = 3.6\text{ V},$ V_{NO} or $V_{\text{NC}} = \text{open}$	25°C			5	nA
			Full			10	
Digital Control Input (IN)							
Input logic high	V_{IH}		Full	$V_+ - 1.5$			V
Input logic low	V_{IL}		Full	V_-		$V_+ - 3.5$	V
Input leakage current	$I_{\text{IH}}, I_{\text{IL}}$	$V_{\text{IN}} = V_+, 0\text{ V}$	Full			0.01	μA
Dynamic							
Turn-on time	t_{ON}	see Figure 2	25°C		65	85	ns
			Full			95	
Turn-off time	t_{OFF}	see Figure 2	25°C		37	60	ns
			Full			70	
Charge injection ⁽⁴⁾	Q_{C}	$C_{\text{L}} = 1\text{ nF}, V_{\text{NO}} = 0\text{ V},$ $R_{\text{S}} = 0\text{ }\Omega$, See Figure 1	25°C		-7.5		pC
NO, NC OFF capacitance	$C_{\text{NO(OFF)}},$ $C_{\text{NC(OFF)}}$	$f = 1\text{ MHz}$, See Figure 4	25°C		5.5		pF
COM OFF capacitance	$C_{\text{COM(OFF)}}$	$f = 1\text{ MHz}$, See Figure 4	25°C		5.5		pF
COM ON capacitance	$C_{\text{COM(ON)}}$	$f = 1\text{ MHz}$, See Figure 4	25°C		16		pF
Digital input capacitance	C_{I}	$V_{\text{IN}} = V_+, 0\text{ V}$	25°C		1.5		pF
Bandwidth	BW	$R_{\text{L}} = 50\text{ }\Omega, C_{\text{L}} = 15\text{ pF},$ $V_{\text{NO}} = 1\text{ V}_{\text{RMS}}, f = 100\text{ kHz}$	25°C		464		MHz
OFF isolation	O_{ISO}	$R_{\text{L}} = 50\text{ }\Omega, C_{\text{L}} = 15\text{ pF},$ $V_{\text{NO}} = 1\text{ V}_{\text{RMS}}, f = 100\text{ kHz}$	25°C		-83		dB
Total harmonic distortion	THD	$R_{\text{L}} = 600\text{ }\Omega, C_{\text{L}} = 15\text{ pF},$ $V_{\text{NO}} = 1\text{ V}_{\text{RMS}}, f = 20\text{ kHz}$	25°C		0.10		%
Supply							
V_+ supply current	I_+	$V_{\text{IN}} = 0\text{ V}$ or V_+	25°C			40	μA
			Full			45	
V_- supply current	I_-	$V_{\text{IN}} = 0\text{ V}$ or V_+	25°C		-40		μA
			Full		45		

(1) The algebraic convention, whereby the most negative value is a minimum and the most positive value is a maximum.

(2) Typical values are at $T_A = 25^\circ\text{C}$.

(3) Leakage parameters are 100% tested at maximum-rated hot operating temperature, and are ensured by correlation at 25°C .

(4) Specified by design, not production tested

Electrical Characteristics for ±1.8-V Supply⁽¹⁾
 $V_+ = 1.65\text{ V to }1.95\text{ V}$, $V_- = -1.65\text{ V to }-1.95\text{ V}$, $T_A = -40^\circ\text{C to }85^\circ\text{C}$ (unless otherwise noted)

PARAMETER	SYMBOL	TEST CONDITIONS	T_A	MIN	TYP ⁽²⁾	MAX	UNIT
Analog Switch							
Analog signal range	$V_{\text{COM}}, V_{\text{NO}}, V_{\text{NC}}$			V_-		V_+	V
ON-state resistance	r_{on}	$V_+ = 1.65\text{ V}, V_- = -1.65\text{ V},$ $V_{\text{COM}} = 0\text{ V},$ $I_{\text{COM}} = 20\text{ mA}$	25°C		28	40	Ω
			Full			47	
ON-state resistance flatness	$r_{\text{on(Flat)}}$	$V_+ = 1.65\text{ V}, V_- = -1.65\text{ V},$ $V_{\text{COM}} = -1.8\text{ V}, 0\text{ V}, 1.5\text{ V},$ $I_{\text{COM}} = 20\text{ mA}$	25°C		9	13	Ω
			Full			15	
NO, NC OFF leakage current ⁽³⁾	$I_{\text{NO(OFF)}},$ $I_{\text{NC(OFF)}}$	$V_+ = 1.95\text{ V}, V_- = -1.95\text{ V},$ $V_{\text{COM}} = 1.65\text{ V},$ $V_{\text{NO}} \text{ or } V_{\text{NC}} = -1.65\text{ V}$	25°C			5	nA
			Full			10	
COM OFF leakage current ⁽³⁾	$I_{\text{COM(OFF)}}$	$V_+ = 1.95\text{ V}, V_- = -1.95\text{ V},$ $V_{\text{COM}} = -1.65\text{ V},$ $V_{\text{NO}} \text{ or } V_{\text{NC}} = 1.65\text{ V}$	25°C			5	nA
			Full			10	
COM ON leakage current ⁽³⁾	$I_{\text{COM(ON)}}$	$V_+ = 1.95\text{ V}, V_- = -1.95\text{ V},$ $V_{\text{COM}} = 1.95\text{ V},$ $V_{\text{NO}} \text{ or } V_{\text{NC}} = \text{open}$	25°C			5	nA
			Full			10	
Digital Control Input (IN)							
Input logic high	V_{IH}		Full	$V_+ - 1.5$			V
Input logic low	V_{IL}		Full	V_-		$V_+ - 3.5$	V
Input leakage current	$I_{\text{IH}}, I_{\text{IL}}$	$V_{\text{IN}} = V_+, 0\text{ V}$	Full			0.01	μA
Dynamic							
Turn-on time ⁽⁴⁾	t_{ON}	See Figure 2	25°C		90	120	ns
			Full			150	
Turn-off time ⁽⁴⁾	t_{OFF}	See Figure 2	25°C		95	150	ns
			Full			200	
Charge injection ⁽⁴⁾	Q_{C}	$C_{\text{L}} = 1\text{ nF}$, See Figure 1	25°C		-3.5		pC
NO, NC OFF capacitance	$C_{\text{NO(OFF)}},$ $C_{\text{NC(OFF)}}$	$f = 1\text{ MHz}$, See Figure 4	25°C		6		pF
COM OFF capacitance	$C_{\text{COM(OFF)}}$	$f = 1\text{ MHz}$, See Figure 4	25°C		6		pF
COM ON capacitance	$C_{\text{COM(ON)}}$	$f = 1\text{ MHz}$, See Figure 4	25°C		14.5		pF
Digital input capacitance	C_{I}	$V_{\text{IN}} = V_+, 0\text{ V}$	25°C		1.5		pF
Bandwidth	BW	$R_{\text{L}} = 50\ \Omega, C_{\text{L}} = 15\text{ pF},$ $V_{\text{NO}} = 1\text{ V}_{\text{RMS}}, f = 100\text{ kHz}$	25°C		464		MHz
OFF isolation	O_{ISO}	$R_{\text{L}} = 50\ \Omega, C_{\text{L}} = 15\text{ pF},$ $V_{\text{NO}} = 1\text{ V}_{\text{RMS}}, f = 1\text{ MHz}$	25°C		-83		dB
Total harmonic distortion	THD	$R_{\text{L}} = 600\ \Omega, C_{\text{L}} = 50\text{ pF},$ $V_{\text{NO}} = 1\text{ V}_{\text{RMS}}, f = 20\text{ kHz}$	25°C		0.37		%
Supply							
V_+ supply current	I_+	$V_{\text{IN}} = 0\text{ V or }V_+$	25°C			20	μA
			Full			30	
V_- supply current	I_-	$V_{\text{IN}} = 0\text{ V or }V_+$	25°C		-20		μA
			Full		-30		

- (1) The algebraic convention, whereby the most negative value is a minimum and the most positive value is a maximum.
 (2) Typical values are at $T_A = 25^\circ\text{C}$.
 (3) Leakage parameters are 100% tested at maximum-rated hot operating temperature, and are ensured by correlation at 25°C.
 (4) Specified by design, not production tested

PIN DESCRIPTION⁽¹⁾

PIN NO.				NAME	DESCRIPTION
TS12A4516		TS12A4517			
D, P	SOT23-5	D, P	SOT23-5		
1	1	1	1	COM	Common
2, 3, 5	–	2, 3, 5	–	N.C.	No connect (not internally connected)
4	5	4	5	V ₊	Positive power supply
6	4	6	4	IN	Digital control to connect COM to NO or NC
7	3	7	3	V ₋	Negative power supply
8	2	–	–	NO	Normally open
–	–	8	2	NC	Normally closed

(1) NO, NC, and COM pins are identical and interchangeable. Any may be considered as an input or an output; signals pass in both directions.

APPLICATION INFORMATION

Power-Supply Considerations

The TS12A4516 and TS12A4517 operate with power-supply voltages from ± 1 V to ± 6 V [$(2 \text{ V} < (V_+ - V_-) < 12 \text{ V})$], but are tested and specified at ± 5 V, ± 3.3 V, and ± 1.8 V supplies. The pin-compatible TS12A4514 and TS12A4515 are recommended for use when only a single supply is desirable.

The TS12A4516 and TS12A4517 construction is typical of most CMOS analog switches, except that they have only two supply pins: V_+ and V_- . V_+ and V_- drive the internal CMOS switches and set their analog voltage limits. Reverse ESD-protection diodes are internally connected between each analog-signal pin and both V_+ and V_- . One of these diodes conducts if any analog signal exceeds V_+ or V_- .

Virtually all the analog leakage current comes from the ESD diodes to V_+ or V_- . Although the ESD diodes on a given signal pin are identical and, therefore, fairly well balanced, they are reverse biased differently. Each is biased by either V_+ or V_- and the analog signal. This means their leakages will vary as the signal varies. The difference in the two diode leakages to the V_+ and V_- pins constitutes the analog-signal-path leakage current. All analog leakage current flows between each pin and one of the supply terminals, not to the other switch terminal. This is why both sides of a given switch can show leakage currents of the same or opposite polarity.

V_+ and V_- also power the internal logic and logic-level translators. The logic-level translators convert the logic levels to switched V_+ and V_- signals to drive the analog signal gates.

Logic-Level Thresholds

Since these parts have no ground pin, the logic-level threshold is referenced to V_+ . The threshold limits are $V_+ - 1.5$ V and $V_+ - 3.5$ V for V_+ levels between 6 V and 3 V. When $V_+ = 2$ V, the logic threshold is approximately 0.6 V.

CAUTION:

Do not connect the TS12A4516/TS12A4517 V_+ to 3 V and then connect the logic-level pins to logic-level signals that operate from 5-V supply. TTL levels can exceed 3 V and violate the absolute maximum ratings, damaging the part and/or external circuits.

Test Circuits/Timing Diagrams

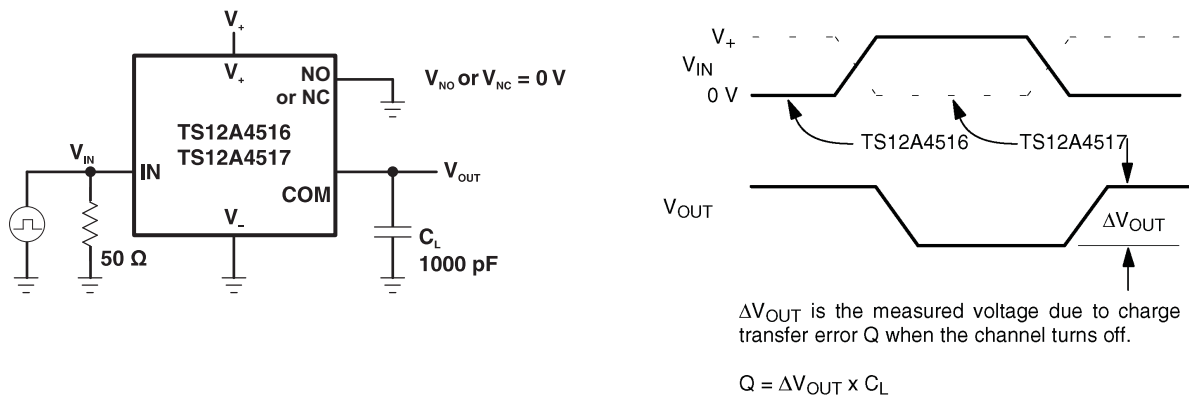

Figure 1. Charge Injection

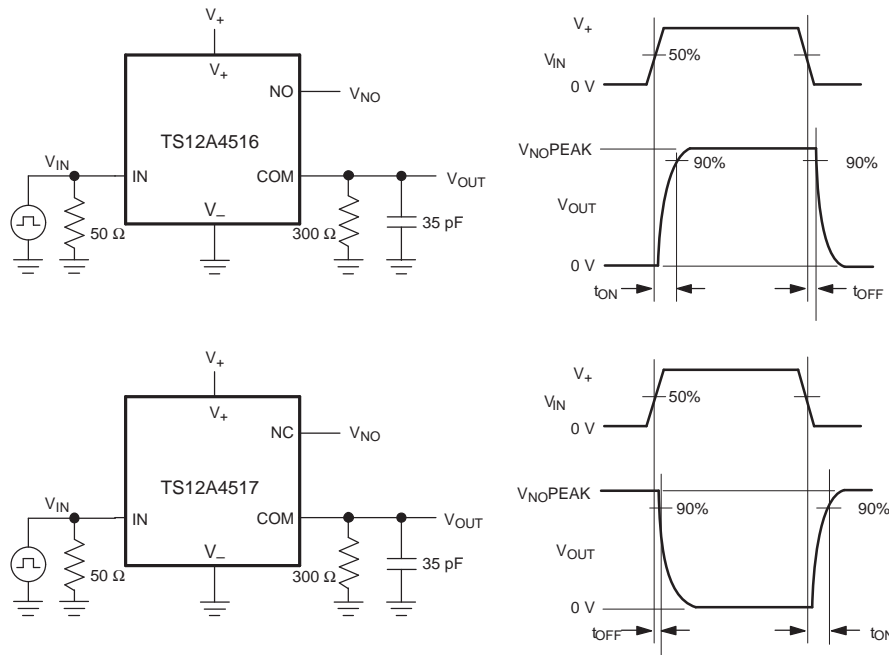
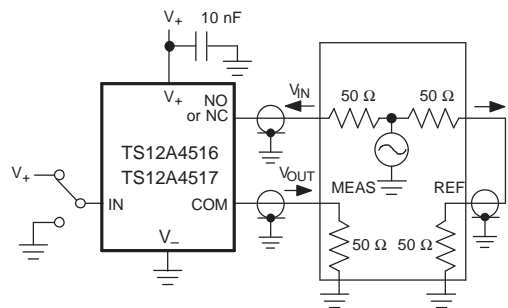

Figure 2. Switching Times



Measurements are standardized against short at socket terminals. OFF isolation is measured between COM and OFF terminals on each switch. ON loss is measured between COM and ON terminals on each switch. Signal direction through switch is reversed; worst values are recorded.

$$\text{OFF Isolation} = 20 \log \frac{V_{OUT}}{V_{IN}}$$

$$\text{ON Loss} = 20 \log \frac{V_{OUT}}{V_{IN}}$$

Figure 3. OFF Isolation and ON Loss

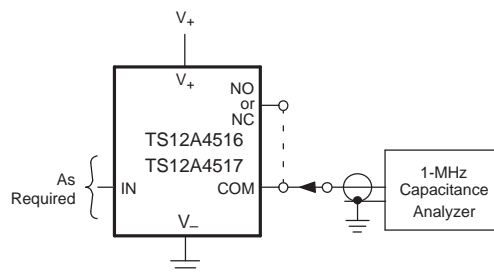

Figure 4. NO, NC, and COM Capacitance

PACKAGING INFORMATION

Orderable Device	Status (1)	Package Type	Package Drawing	Pins	Package Qty	Eco Plan (2)	Lead/Ball Finish	MSL Peak Temp (3)	Op Temp (°C)	Device Marking (4/5)	Samples
TS12A4516D	ACTIVE	SOIC	D	8	75	Green (RoHS & no Sb/Br)	CU NIPDAU	Level-1-260C-UNLIM	-40 to 85	YD516	Samples
TS12A4516DBVR	ACTIVE	SOT-23	DBV	5	3000	Green (RoHS & no Sb/Br)	CU NIPDAU	Level-1-260C-UNLIM	-40 to 85	(9CLA ~ 9CLM)	Samples
TS12A4516DG4	ACTIVE	SOIC	D	8	75	Green (RoHS & no Sb/Br)	CU NIPDAU	Level-1-260C-UNLIM	-40 to 85	YD516	Samples
TS12A4516DR	ACTIVE	SOIC	D	8	2500	Green (RoHS & no Sb/Br)	CU NIPDAU	Level-1-260C-UNLIM	-40 to 85	YD516	Samples
TS12A4516DRG4	ACTIVE	SOIC	D	8	2500	Green (RoHS & no Sb/Br)	CU NIPDAU	Level-1-260C-UNLIM	-40 to 85	YD516	Samples
TS12A4517D	ACTIVE	SOIC	D	8	75	Green (RoHS & no Sb/Br)	CU NIPDAU	Level-1-260C-UNLIM	-40 to 85	YD517	Samples
TS12A4517DBVR	ACTIVE	SOT-23	DBV	5	3000	Green (RoHS & no Sb/Br)	CU NIPDAU	Level-1-260C-UNLIM	-40 to 85	(9CMA ~ 9CMM)	Samples
TS12A4517DG4	ACTIVE	SOIC	D	8	75	Green (RoHS & no Sb/Br)	CU NIPDAU	Level-1-260C-UNLIM	-40 to 85	YD517	Samples
TS12A4517DR	ACTIVE	SOIC	D	8	2500	Green (RoHS & no Sb/Br)	CU NIPDAU	Level-1-260C-UNLIM	-40 to 85	YD517	Samples
TS12A4517DRG4	ACTIVE	SOIC	D	8	2500	Green (RoHS & no Sb/Br)	CU NIPDAU	Level-1-260C-UNLIM	-40 to 85	YD517	Samples

(1) The marketing status values are defined as follows:

ACTIVE: Product device recommended for new designs.

LIFEBUY: TI has announced that the device will be discontinued, and a lifetime-buy period is in effect.

NRND: Not recommended for new designs. Device is in production to support existing customers, but TI does not recommend using this part in a new design.

PREVIEW: Device has been announced but is not in production. Samples may or may not be available.

OBSOLETE: TI has discontinued the production of the device.

(2) Eco Plan - The planned eco-friendly classification: Pb-Free (RoHS), Pb-Free (RoHS Exempt), or Green (RoHS & no Sb/Br) - please check <http://www.ti.com/productcontent> for the latest availability information and additional product content details.

TBD: The Pb-Free/Green conversion plan has not been defined.

Pb-Free (RoHS): TI's terms "Lead-Free" or "Pb-Free" mean semiconductor products that are compatible with the current RoHS requirements for all 6 substances, including the requirement that lead not exceed 0.1% by weight in homogeneous materials. Where designed to be soldered at high temperatures, TI Pb-Free products are suitable for use in specified lead-free processes.

Pb-Free (RoHS Exempt): This component has a RoHS exemption for either 1) lead-based flip-chip solder bumps used between the die and package, or 2) lead-based die adhesive used between the die and leadframe. The component is otherwise considered Pb-Free (RoHS compatible) as defined above.

Green (RoHS & no Sb/Br): TI defines "Green" to mean Pb-Free (RoHS compatible), and free of Bromine (Br) and Antimony (Sb) based flame retardants (Br or Sb do not exceed 0.1% by weight in homogeneous material)

(3) MSL, Peak Temp. -- The Moisture Sensitivity Level rating according to the JEDEC industry standard classifications, and peak solder temperature.

(4) There may be additional marking, which relates to the logo, the lot trace code information, or the environmental category on the device.

(5) Multiple Device Markings will be inside parentheses. Only one Device Marking contained in parentheses and separated by a "~" will appear on a device. If a line is indented then it is a continuation of the previous line and the two combined represent the entire Device Marking for that device.

Important Information and Disclaimer:The information provided on this page represents TI's knowledge and belief as of the date that it is provided. TI bases its knowledge and belief on information provided by third parties, and makes no representation or warranty as to the accuracy of such information. Efforts are underway to better integrate information from third parties. TI has taken and continues to take reasonable steps to provide representative and accurate information but may not have conducted destructive testing or chemical analysis on incoming materials and chemicals. TI and TI suppliers consider certain information to be proprietary, and thus CAS numbers and other limited information may not be available for release.

In no event shall TI's liability arising out of such information exceed the total purchase price of the TI part(s) at issue in this document sold by TI to Customer on an annual basis.

TAPE AND REEL INFORMATION
REEL DIMENSIONS

TAPE DIMENSIONS

A0	Dimension designed to accommodate the component width
B0	Dimension designed to accommodate the component length
K0	Dimension designed to accommodate the component thickness
W	Overall width of the carrier tape
P1	Pitch between successive cavity centers

TAPE AND REEL INFORMATION

*All dimensions are nominal

Device	Package Type	Package Drawing	Pins	SPQ	Reel Diameter (mm)	Reel Width W1 (mm)	A0 (mm)	B0 (mm)	K0 (mm)	P1 (mm)	W (mm)	Pin1 Quadrant
TS12A4516DBVR	SOT-23	DBV	5	3000	180.0	8.4	3.23	3.17	1.37	4.0	8.0	Q3
TS12A4516DR	SOIC	D	8	2500	330.0	12.4	6.4	5.2	2.1	8.0	12.0	Q1
TS12A4517DR	SOIC	D	8	2500	330.0	12.4	6.4	5.2	2.1	8.0	12.0	Q1

TAPE AND REEL BOX DIMENSIONS



*All dimensions are nominal

Device	Package Type	Package Drawing	Pins	SPQ	Length (mm)	Width (mm)	Height (mm)
TS12A4516DBVR	SOT-23	DBV	5	3000	202.0	201.0	28.0
TS12A4516DR	SOIC	D	8	2500	367.0	367.0	35.0
TS12A4517DR	SOIC	D	8	2500	367.0	367.0	35.0

DBV (R-PDSO-G5)

PLASTIC SMALL-OUTLINE PACKAGE

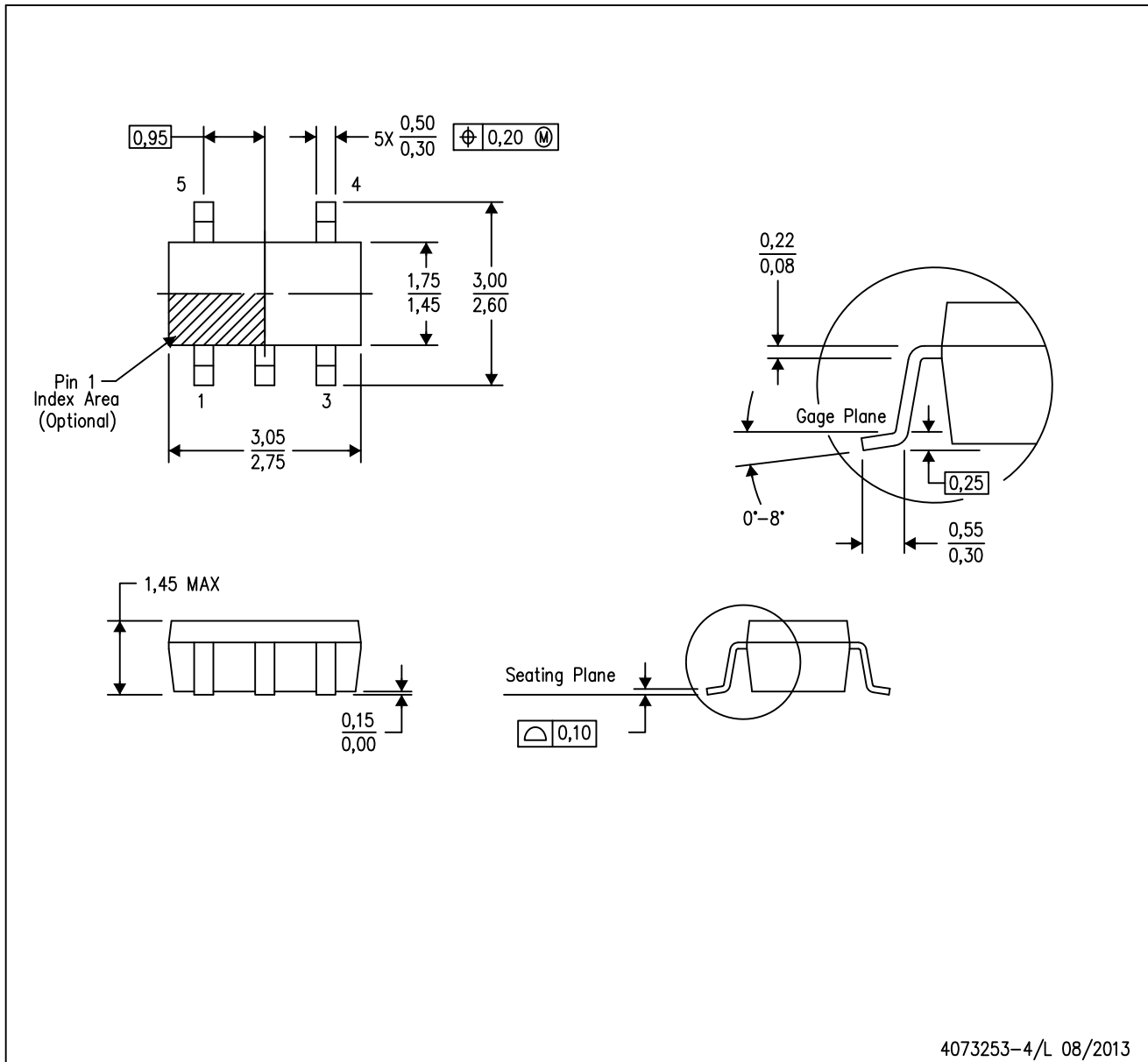

- NOTES:
- A. All linear dimensions are in millimeters.
 - B. This drawing is subject to change without notice.
 - C. Body dimensions do not include mold flash or protrusion. Mold flash and protrusion shall not exceed 0.15 per side.
 - D. Falls within JEDEC MO-178 Variation AA.

DBV (R-PDSO-G5)

PLASTIC SMALL OUTLINE



- NOTES:
- A. All linear dimensions are in millimeters.
 - B. This drawing is subject to change without notice.
 - C. Customers should place a note on the circuit board fabrication drawing not to alter the center solder mask defined pad.
 - D. Publication IPC-7351 is recommended for alternate designs.
 - E. Laser cutting apertures with trapezoidal walls and also rounding corners will offer better paste release. Customers should contact their board assembly site for stencil design recommendations. Example stencil design based on a 50% volumetric metal load solder paste. Refer to IPC-7525 for other stencil recommendations.

D (R-PDSO-G8)

PLASTIC SMALL OUTLINE

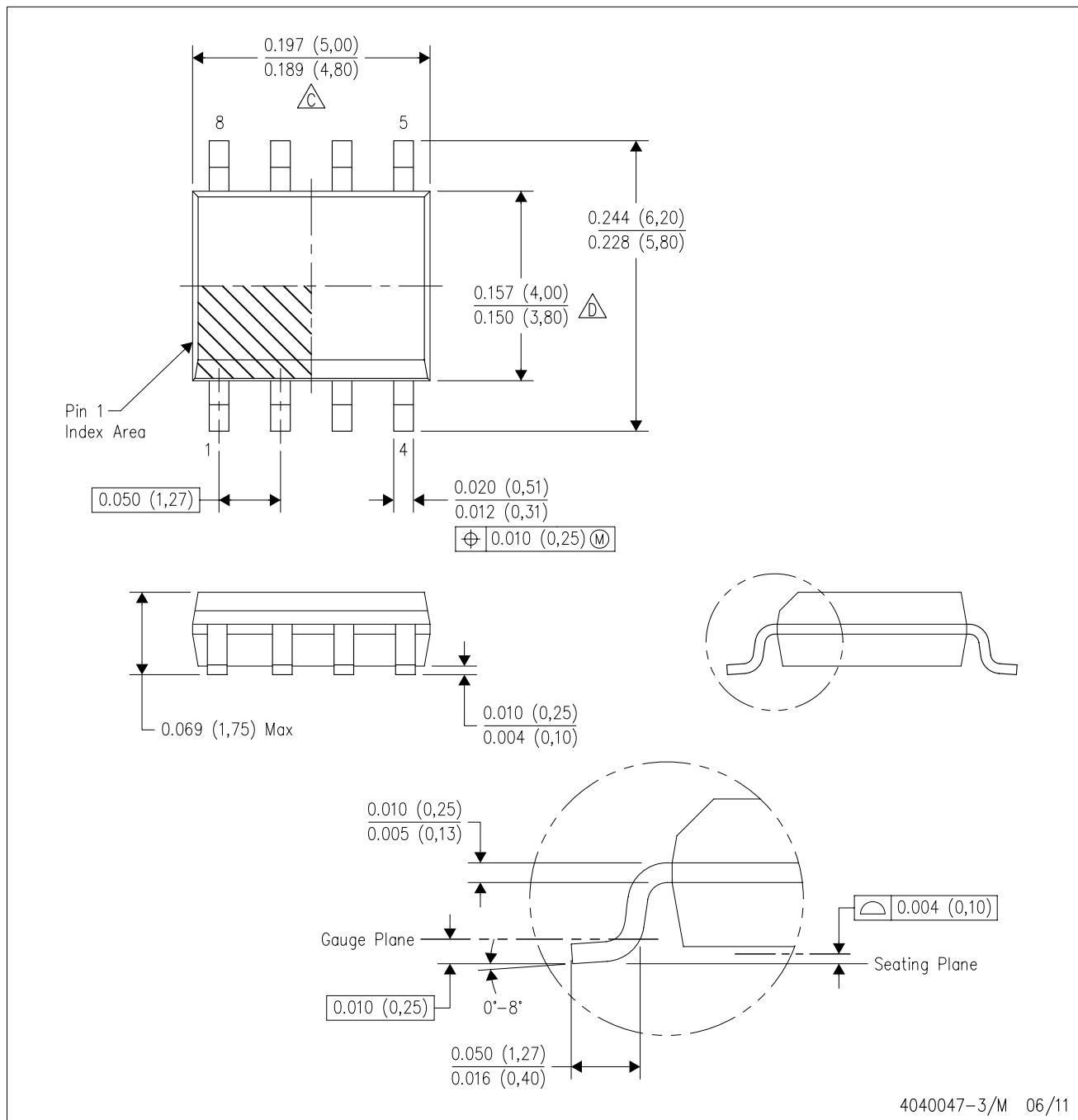

- NOTES:
- A. All linear dimensions are in inches (millimeters).
 - B. This drawing is subject to change without notice.
 - C. Body length does not include mold flash, protrusions, or gate burrs. Mold flash, protrusions, or gate burrs shall not exceed 0.006 (0,15) each side.
 - D. Body width does not include interlead flash. Interlead flash shall not exceed 0.017 (0,43) each side.
 - E. Reference JEDEC MS-012 variation AA.

D (R-PDSO-G8)

PLASTIC SMALL OUTLINE



4211283-2/E 08/12

- NOTES:
- A. All linear dimensions are in millimeters.
 - B. This drawing is subject to change without notice.
 - C. Publication IPC-7351 is recommended for alternate designs.
 - D. Laser cutting apertures with trapezoidal walls and also rounding corners will offer better paste release. Customers should contact their board assembly site for stencil design recommendations. Refer to IPC-7525 for other stencil recommendations.
 - E. Customers should contact their board fabrication site for solder mask tolerances between and around signal pads.

IMPORTANT NOTICE

Texas Instruments Incorporated and its subsidiaries (TI) reserve the right to make corrections, enhancements, improvements and other changes to its semiconductor products and services per JESD46, latest issue, and to discontinue any product or service per JESD48, latest issue. Buyers should obtain the latest relevant information before placing orders and should verify that such information is current and complete. All semiconductor products (also referred to herein as "components") are sold subject to TI's terms and conditions of sale supplied at the time of order acknowledgment.

TI warrants performance of its components to the specifications applicable at the time of sale, in accordance with the warranty in TI's terms and conditions of sale of semiconductor products. Testing and other quality control techniques are used to the extent TI deems necessary to support this warranty. Except where mandated by applicable law, testing of all parameters of each component is not necessarily performed.

TI assumes no liability for applications assistance or the design of Buyers' products. Buyers are responsible for their products and applications using TI components. To minimize the risks associated with Buyers' products and applications, Buyers should provide adequate design and operating safeguards.

TI does not warrant or represent that any license, either express or implied, is granted under any patent right, copyright, mask work right, or other intellectual property right relating to any combination, machine, or process in which TI components or services are used. Information published by TI regarding third-party products or services does not constitute a license to use such products or services or a warranty or endorsement thereof. Use of such information may require a license from a third party under the patents or other intellectual property of the third party, or a license from TI under the patents or other intellectual property of TI.

Reproduction of significant portions of TI information in TI data books or data sheets is permissible only if reproduction is without alteration and is accompanied by all associated warranties, conditions, limitations, and notices. TI is not responsible or liable for such altered documentation. Information of third parties may be subject to additional restrictions.

Resale of TI components or services with statements different from or beyond the parameters stated by TI for that component or service voids all express and any implied warranties for the associated TI component or service and is an unfair and deceptive business practice. TI is not responsible or liable for any such statements.

Buyer acknowledges and agrees that it is solely responsible for compliance with all legal, regulatory and safety-related requirements concerning its products, and any use of TI components in its applications, notwithstanding any applications-related information or support that may be provided by TI. Buyer represents and agrees that it has all the necessary expertise to create and implement safeguards which anticipate dangerous consequences of failures, monitor failures and their consequences, lessen the likelihood of failures that might cause harm and take appropriate remedial actions. Buyer will fully indemnify TI and its representatives against any damages arising out of the use of any TI components in safety-critical applications.

In some cases, TI components may be promoted specifically to facilitate safety-related applications. With such components, TI's goal is to help enable customers to design and create their own end-product solutions that meet applicable functional safety standards and requirements. Nonetheless, such components are subject to these terms.

No TI components are authorized for use in FDA Class III (or similar life-critical medical equipment) unless authorized officers of the parties have executed a special agreement specifically governing such use.

Only those TI components which TI has specifically designated as military grade or "enhanced plastic" are designed and intended for use in military/aerospace applications or environments. Buyer acknowledges and agrees that any military or aerospace use of TI components which have **not** been so designated is solely at the Buyer's risk, and that Buyer is solely responsible for compliance with all legal and regulatory requirements in connection with such use.

TI has specifically designated certain components as meeting ISO/TS16949 requirements, mainly for automotive use. In any case of use of non-designated products, TI will not be responsible for any failure to meet ISO/TS16949.

Products

Audio	www.ti.com/audio
Amplifiers	amplifier.ti.com
Data Converters	dataconverter.ti.com
DLP® Products	www.dlp.com
DSP	dsp.ti.com
Clocks and Timers	www.ti.com/clocks
Interface	interface.ti.com
Logic	logic.ti.com
Power Mgmt	power.ti.com
Microcontrollers	microcontroller.ti.com
RFID	www.ti-rfid.com
OMAP Applications Processors	www.ti.com/omap
Wireless Connectivity	www.ti.com/wirelessconnectivity

Applications

Automotive and Transportation	www.ti.com/automotive
Communications and Telecom	www.ti.com/communications
Computers and Peripherals	www.ti.com/computers
Consumer Electronics	www.ti.com/consumer-apps
Energy and Lighting	www.ti.com/energy
Industrial	www.ti.com/industrial
Medical	www.ti.com/medical
Security	www.ti.com/security
Space, Avionics and Defense	www.ti.com/space-avionics-defense
Video and Imaging	www.ti.com/video

TI E2E Community

e2e.ti.com

Mouser Electronics

Authorized Distributor

Click to View Pricing, Inventory, Delivery & Lifecycle Information:

Texas Instruments:

[TS12A4516DBVR](#) [TS12A4517DBVR](#) [TS12A4516D](#) [TS12A4516DG4](#) [TS12A4516DR](#) [TS12A4516DRG4](#)
[TS12A4517D](#) [TS12A4517DG4](#) [TS12A4517DR](#) [TS12A4517DRG4](#)