

## FEATURES

- Operates With 3-V to 5.5-V  $V_{CC}$  Supply
- Operates up to 1 Mbit/s
- Low Supply Current . . . 300  $\mu$ A Typ
- External Capacitors . . .  $4 \times 0.1 \mu$ F
- Accept 5-V Logic Input With 3.3-V Supply
- Latch-Up Performance Exceeds 100 mA Per JESD 78, Class II
- ESD Protection for RS-232 Pins
  - ±15-kV Human-Body Model (HBM)
  - ±15-kV IEC 61000-4-2 Air-Gap Discharge
  - ±8-kV IEC 61000-4-2 Contact Discharge

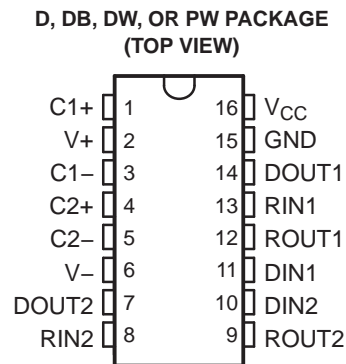

## APPLICATIONS

- Battery-Powered Systems
- PDAs
- Notebooks
- Laptops
- Palmtop PCs
- Hand-Held Equipment

## DESCRIPTION/ORDERING INFORMATION

The TRSF3232E consists of two line drivers, two line receivers, and a dual charge-pump circuit with ±15-kV ESD protection pin to pin (serial-port connection pins, including GND). This device provides the electrical interface between an asynchronous communication controller and the serial-port connector. The charge pump and four small external capacitors allow operation from a single 3-V to 5.5-V supply. The TRSF3232E operates at data signaling rates up to 1 Mbit/s and a driver output slew rate of 14 V/ $\mu$ s to 150 V/ $\mu$ s.

### ORDERING INFORMATION

$T_A$	PACKAGE <sup>(1)(2)</sup>		ORDERABLE PART NUMBER	TOP-SIDE MARKING
0°C to 70°C	SOIC – D	Tube of 40	TRSF3232ECD	TRSF3232EC
		Reel of 2500	TRSF3232ECDR	
	SOIC – DW	Tube of 40	TRSF3232ECDW	TRSF3232EC
		Reel of 2000	TRSF3232ECDWR	
	SSOP – DB	Reel of 2000	TRSF3232ECDBR	RT32EC
	TSSOP – PW	Tube of 90	TRSF3232ECPW	RT32EC
Reel of 2000		TRSF3232ECPWR		
–40°C to 85°C	SOIC – D	Tube of 40	TRSF3232EID	TRSF3232EI
		SOIC – DW	TRSF3232EIDR	
	SOIC – DW	Tube of 40	TRSF3232EIDW	TRSF3232EI
		TSSOP – PW	TRSF3232EIDWR	
	SSOP – DB	Reel of 2000	TRSF3232EIDBR	RT32EI
	TSSOP – PW	Tube of 90	TRSF3232EIPW	RT32EI
		Reel of 2000	TRSF3232EIPWR	

(1) Package drawings, thermal data, and symbolization are available at [www.ti.com/packaging](http://www.ti.com/packaging).

(2) For the most current package and ordering information, see the Package Option Addendum at the end of this document, or see the TI website at [www.ti.com](http://www.ti.com).



Please be aware that an important notice concerning availability, standard warranty, and use in critical applications of Texas Instruments semiconductor products and disclaimers thereto appears at the end of this data sheet.

**TRSF3232E**  
**3-V TO 5.5-V TWO-CHANNEL RS-232 1-Mbit/s LINE DRIVER/RECEIVER**  
**WITH  $\pm 15$ -kV IEC ESD PROTECTION**

SLLS825–AUGUST 2007

**Table 1. 1-Mbit/s RS-232 Parts**

TEMPERATURE RANGE	PART NO.	NO. OF DRIVERS	NO. OF RECEIVERS	ESD	SUPPLY $V_{CC}$ (V)	FEATURE	PIN/PACKAGE
0°C to 70°C	TRSF3221E	1	1	$\pm 15$ -kV Air-Gap Discharge, $\pm 8$ -kV Contact Discharge, $\pm 15$ -kV HBM	3.3 or 5	Auto-powerdown	16-pin SOIC, SSOP, TSSOP
	TRSF3232E	2	2	$\pm 15$ -kV Air-Gap Discharge, $\pm 8$ -kV Contact Discharge, $\pm 15$ -kV HBM	3.3 or 5	Low pin count	16-pin SOIC, SSOP, TSSOP
	TRS3227	1	1	$\pm 8$ -kV Air-Gap Discharge, $\pm 8$ -kV Contact Discharge, $\pm 15$ -kV HBM	3.3 or 5	Auto-powerdown plus, ready signal	16-pin SSOP
	TRSF3221	1	1	$\pm 15$ -kV HBM	3.3 or 5	Auto-powerdown	16-pin SOIC, SSOP, TSSOP
	TRSF3222	2	2	$\pm 15$ -kV HBM	3.3 or 5	Enable, powerdown signal	20-pin SOIC, SSOP, TSSOP
	TRSF3223	2	2	$\pm 15$ -kV HBM	3.5 or 5	Auto-powerdown, enable signal	20-pin SOIC, SSOP, TSSOP
	TRSF3232	2	2	$\pm 15$ -kV HBM	3.3 or 5	Low pin count	16-pin SOIC, SSOP, TSSOP
	TRSF3238	5	3	$\pm 15$ -kV HBM	3.3 or 5	Auto-powerdown plus	28-pin SOIC, SSOP, TSSOP
	TRSF3243	3	5	$\pm 15$ -kV HBM	3.3 or 5	Auto-powerdown	28-pin SOIC, SSOP, TSSOP
–40°C to 85°C	TRSF3221E	1	1	$\pm 15$ -kV Air-Gap Discharge, $\pm 8$ -kV Contact Discharge, $\pm 15$ -kV HBM	3.3 or 5	Auto-powerdown	16-pin SOIC, SSOP, TSSOP
	TRSF3232E	2	2	$\pm 15$ -kV Air-Gap Discharge, $\pm 8$ -kV Contact Discharge, $\pm 15$ -kV HBM	3.3 or 5	Low pin count	16-pin SOIC, SSOP, TSSOP
	TRS3227	1	1	$\pm 8$ -kV Air-Gap Discharge, $\pm 8$ -kV Contact Discharge, $\pm 15$ -kV HBM	3.3 or 5	Auto-powerdown plus, ready signal	16-pin SSOP
	TRSF3221	1	1	$\pm 15$ -kV HBM	3.3 or 5	Auto-powerdown	16-pin SOIC, SSOP, TSSOP
	TRSF3222	2	2	$\pm 15$ -kV HBM	3.3 or 5	Enable, powerdown signal	20-pin SOIC, SSOP, TSSOP
	TRSF3223	2	2	$\pm 15$ -kV HBM	3.3 or 5	Auto-powerdown, enable signal	20-pin SOIC, SSOP, TSSOP
	TRSF3232	2	2	$\pm 15$ -kV HBM	3.3 or 5	Low pin count	16-pin SOIC, SSOP, TSSOP
	TRSF3238	5	3	$\pm 15$ -kV HBM	3.3 or 5	Auto-powerdown plus	28-pin SOIC, SSOP, TSSOP
	TRSF3243	3	5	$\pm 15$ -kV HBM	3.3 or 5	Auto-powerdown	28-pin SOIC, SSOP, TSSOP

### FUNCTION TABLES

#### Each Driver<sup>(1)</sup>

INPUT DIN	OUTPUT DOUT
L	H
H	L

(1) H = high level, L = low level

#### Each Receiver<sup>(1)</sup>

INPUT RIN	OUTPUT ROUT
L	H
H	L
Open	H

(1) H = high level, L = low level,  
Open = input disconnected or  
connected driver off

### LOGIC DIAGRAM (POSITIVE LOGIC)

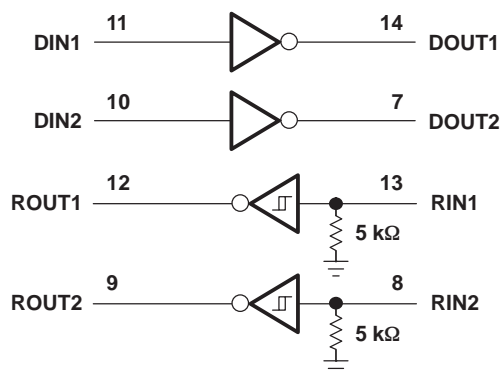

**TRSF3232E**  
**3-V TO 5.5-V TWO-CHANNEL RS-232 1-Mbit/s LINE DRIVER/RECEIVER**  
**WITH  $\pm 15$ -kV IEC ESD PROTECTION**

SLLS825–AUGUST 2007

**Absolute Maximum Ratings<sup>(1)</sup>**

over operating free-air temperature range (unless otherwise noted)

		MIN	MAX	UNIT	
V <sub>CC</sub>	Supply voltage range <sup>(2)</sup>	–0.3	6	V	
V+	Positive-output supply voltage range <sup>(2)</sup>	–0.3	7	V	
V–	Negative-output supply voltage range <sup>(2)</sup>	0.3	–7	V	
V+ – V–	Supply voltage difference <sup>(2)</sup>		13	V	
V <sub>I</sub>	Input voltage range	Drivers	–0.3	6	V
		Receivers	–25	25	
V <sub>O</sub>	Output voltage range	Drivers	–13.2	13.2	V
		Receivers	–0.3	V <sub>CC</sub> + 0.3	
θ <sub>JA</sub>	Package thermal impedance <sup>(3)(4)</sup>	D package		82	°C/W
		DB package		46	
		DW package		57	
		PW package		108	
T <sub>J</sub>	Operating virtual junction temperature		150	°C	
T <sub>stg</sub>	Storage temperature range	–65	150	°C	

- (1) Stresses beyond those listed under "absolute maximum ratings" may cause permanent damage to the device. These are stress ratings only, and functional operation of the device at these or any other conditions beyond those indicated under "recommended operating conditions" is not implied. Exposure to absolute-maximum-rated conditions for extended periods may affect device reliability.
- (2) All voltages are with respect to network GND.
- (3) Maximum power dissipation is a function of T<sub>J</sub>(max), θ<sub>JA</sub>, and T<sub>A</sub>. The maximum allowable power dissipation at any allowable ambient temperature is P<sub>D</sub> = (T<sub>J</sub>(max) – T<sub>A</sub>)/θ<sub>JA</sub>. Operating at the absolute maximum T<sub>J</sub> of 150°C can affect reliability.
- (4) The package thermal impedance is calculated in accordance with JESD 51-7.

**Recommended Operating Conditions<sup>(1)</sup>**

		MIN	NOM	MAX	UNIT	
Supply voltage		V <sub>CC</sub> = 3.3 V	3	3.3	3.6	V
		V <sub>CC</sub> = 5 V	4.5	5	5.5	
V <sub>IH</sub>	Driver high-level input voltage	DIN	V <sub>CC</sub> = 3.3 V	2		V
			V <sub>CC</sub> = 5 V	2.4		
V <sub>IL</sub>	Driver low-level input voltage	DIN		0.8	V	
V <sub>I</sub>	Driver input voltage	DIN	0	5.5	V	
	Receiver input voltage		–25	25		
T <sub>A</sub>	Operating free-air temperature	TRSF3232EI	–40	85	°C	
		TRSF3232EC	0	70		

- (1) Test conditions are C1–C4 = 0.1 μF at V<sub>CC</sub> = 3.3 V ± 0.3 V; C1 = 0.047 μF, C2–C4 = 0.33 μF at V<sub>CC</sub> = 5 V ± 0.5 V (see Figure 4).

**Electrical Characteristics<sup>(1)</sup>**

over recommended ranges of supply voltage and operating free-air temperature (unless otherwise noted)

PARAMETER	TEST CONDITIONS	MIN	TYP <sup>(2)</sup>	MAX	UNIT
I <sub>CC</sub>	Supply current	No load, V <sub>CC</sub> = 3.3 V or 5 V	0.3	1	mA

- (1) Test conditions are C1–C4 = 0.1 μF at V<sub>CC</sub> = 3.3 V ± 0.3 V; C1 = 0.047 μF, C2–C4 = 0.33 μF at V<sub>CC</sub> = 5 V ± 0.5 V (see Figure 4).
- (2) All typical values are at V<sub>CC</sub> = 3.3 V or V<sub>CC</sub> = 5 V, and T<sub>A</sub> = 25°C.

## DRIVER SECTION

### Electrical Characteristics<sup>(1)</sup>

over recommended ranges of supply voltage and operating free-air temperature (unless otherwise noted)

PARAMETER	TEST CONDITIONS	MIN	TYP <sup>(2)</sup>	MAX	UNIT
V <sub>OH</sub> High-level output voltage	DOUT at R <sub>L</sub> = 3 k $\Omega$ to GND, DIN = GND	5	5.5		V
V <sub>OL</sub> Low-level output voltage	DOUT at R <sub>L</sub> = 3 k $\Omega$ to GND, DIN = V <sub>CC</sub>	–5	–5.4		V
I <sub>IH</sub> High-level input current	V <sub>I</sub> = V <sub>CC</sub>		$\pm 0.01$	$\pm 1$	$\mu$ A
I <sub>IL</sub> Low-level input current	V <sub>I</sub> at GND		$\pm 0.01$	$\pm 1$	$\mu$ A
I <sub>OS</sub> <sup>(3)</sup> Short-circuit output current	V <sub>CC</sub> = 3.6 V, V <sub>O</sub> = 0 V		$\pm 35$	$\pm 60$	mA
	V <sub>CC</sub> = 5.5 V, V <sub>O</sub> = 0 V		$\pm 35$	$\pm 90$	
r <sub>o</sub> Output resistance	V <sub>CC</sub> , V <sub>+</sub> , and V <sub>–</sub> = 0 V, V <sub>O</sub> = $\pm 2$ V	300	10M		$\Omega$

(1) Test conditions are C1–C4 = 0.1  $\mu$ F at V<sub>CC</sub> = 3.3 V  $\pm$  0.3 V; C1 = 0.047  $\mu$ F, C2–C4 = 0.33  $\mu$ F at V<sub>CC</sub> = 5 V  $\pm$  0.5 V (see Figure 4).

(2) All typical values are at V<sub>CC</sub> = 3.3 V or V<sub>CC</sub> = 5 V, and T<sub>A</sub> = 25°C.

(3) Short-circuit durations should be controlled to prevent exceeding the device absolute power dissipation ratings, and not more than one output should be shorted at a time.

### Switching Characteristics<sup>(1)</sup>

over recommended ranges of supply voltage and operating free-air temperature (unless otherwise noted)

PARAMETER	TEST CONDITIONS	MIN	TYP <sup>(2)</sup>	MAX	UNIT
Maximum data rate (see Figure 1)	R <sub>L</sub> = 3 k $\Omega$ , One DOUT switching	C <sub>L</sub> = 250 pF, V <sub>CC</sub> = 3 V to 4.5 V	1000		kbit/s
		C <sub>L</sub> = 1000 pF, V <sub>CC</sub> = 3.5 V to 5.5 V	1000		
t <sub>sk(p)</sub> Pulse skew <sup>(3)</sup>	C <sub>L</sub> = 150 pF to 2500 pF, R <sub>L</sub> = 3 k $\Omega$ to 7 k $\Omega$ , See Figure 2		300		ns
SR(tr) Slew rate, transition region (see Figure 1)	R <sub>L</sub> = 3 k $\Omega$ to 7 k $\Omega$ , C <sub>L</sub> = 150 pF to 1000 pF, V <sub>CC</sub> = 3.3 V		14	150	V/ $\mu$ s

(1) Test conditions are C1–C4 = 0.1  $\mu$ F at V<sub>CC</sub> = 3.3 V  $\pm$  0.3 V; C1 = 0.047  $\mu$ F, C2–C4 = 0.33  $\mu$ F at V<sub>CC</sub> = 5 V  $\pm$  0.5 V (see Figure 4).

(2) All typical values are at V<sub>CC</sub> = 3.3 V or V<sub>CC</sub> = 5 V, and T<sub>A</sub> = 25°C.

(3) Pulse skew is defined as |t<sub>PLH</sub> – t<sub>PHL</sub>| of each channel of the same device.

## ESD Protection

TERMINAL		TEST CONDITIONS	TYP	UNIT
NAME	NO.			
DOUT	7, 14	HBM	$\pm 15$	kV
		IEC 61000-4-2 Air-Gap Discharge	$\pm 15$	
		IEC 61000-4-2 Contact Discharge	$\pm 8$	

**TRSF3232E**  
**3-V TO 5.5-V TWO-CHANNEL RS-232 1-Mbit/s LINE DRIVER/RECEIVER**  
**WITH  $\pm 15$ -kV IEC ESD PROTECTION**

SLLS825 – AUGUST 2007

**RECEIVER SECTION**

**Electrical Characteristics<sup>(1)</sup>**

over recommended ranges of supply voltage and operating free-air temperature (unless otherwise noted)

PARAMETER		TEST CONDITIONS	MIN	TYP <sup>(2)</sup>	MAX	UNIT
V <sub>OH</sub>	High-level output voltage	I <sub>OH</sub> = -1 mA	V <sub>CC</sub> - 0.6	V <sub>CC</sub> - 0.1		V
V <sub>OL</sub>	Low-level output voltage	I <sub>OL</sub> = 1.6 mA			0.4	V
V <sub>IT+</sub>	Positive-going input threshold voltage	V <sub>CC</sub> = 3.3 V		1.5	2.4	V
		V <sub>CC</sub> = 5 V		1.8	2.4	
V <sub>IT-</sub>	Negative-going input threshold voltage	V <sub>CC</sub> = 3.3 V	0.6	1.2		V
		V <sub>CC</sub> = 5 V	0.8	1.5		
V <sub>hys</sub>	Input hysteresis (V <sub>IT+</sub> - V <sub>IT-</sub> )			0.3		V
r <sub>i</sub>	Input resistance	V <sub>i</sub> = $\pm 3$ V to $\pm 25$ V	3	5	7	k $\Omega$

(1) Test conditions are C1–C4 = 0.1  $\mu$ F at V<sub>CC</sub> = 3.3 V  $\pm$  0.3 V; C1 = 0.047  $\mu$ F, C2–C4 = 0.33  $\mu$ F at V<sub>CC</sub> = 5 V  $\pm$  0.5 V (see Figure 4).

(2) All typical values are at V<sub>CC</sub> = 3.3 V or V<sub>CC</sub> = 5 V, and T<sub>A</sub> = 25°C.

**Switching Characteristics<sup>(1)</sup>**

over recommended ranges of supply voltage and operating free-air temperature (unless otherwise noted)

PARAMETER		TEST CONDITIONS	TYP <sup>(2)</sup>	UNIT
t <sub>PLH</sub>	Propagation delay time, low- to high-level output	C <sub>L</sub> = 150 pF	300	ns
t <sub>PHL</sub>	Propagation delay time, high- to low-level output	C <sub>L</sub> = 150 pF	300	ns
t <sub>sk(p)</sub>	Pulse skew <sup>(3)</sup>		300	ns

(1) Test conditions are C1–C4 = 0.1  $\mu$ F at V<sub>CC</sub> = 3.3 V  $\pm$  0.3 V; C1 = 0.047  $\mu$ F, C2–C4 = 0.33  $\mu$ F at V<sub>CC</sub> = 5 V  $\pm$  0.5 V (see Figure 4).

(2) All typical values are at V<sub>CC</sub> = 3.3 V or V<sub>CC</sub> = 5 V, and T<sub>A</sub> = 25°C.

(3) Pulse skew is defined as |t<sub>PLH</sub> - t<sub>PHL</sub>| of each channel of the same device.

**ESD Protection**

TERMINAL		TEST CONDITIONS	TYP	UNIT
NAME	NO.			
RIN	8, 13	HBM	$\pm 15$	kV
		IEC 61000-4-2 Air-Gap Discharge	$\pm 15$	
		IEC 61000-4-2 Contact Discharge	$\pm 8$	

PARAMETER MEASUREMENT INFORMATION

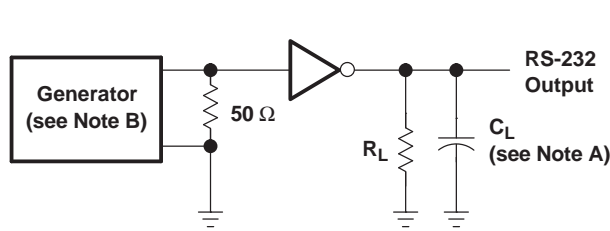

TEST CIRCUIT

$$SR(tr) = \frac{6\text{ V}}{t_{THL} \text{ or } t_{TLH}}$$

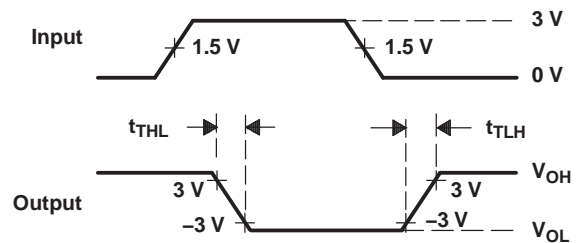

VOLTAGE WAVEFORMS

NOTES: A.  $C_L$  includes probe and jig capacitance.

B. The pulse generator has the following characteristics: PRR = 250 kbit/s,  $Z_O = 50\ \Omega$ , 50% duty cycle,  $t_r \leq 10\text{ ns}$ ,  $t_f \leq 10\text{ ns}$ .

Figure 1. Driver Slew Rate

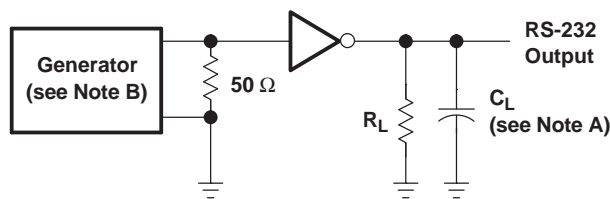

TEST CIRCUIT

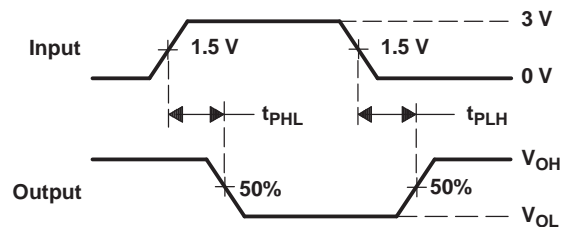

VOLTAGE WAVEFORMS

NOTES: A.  $C_L$  includes probe and jig capacitance.

B. The pulse generator has the following characteristics: PRR = 250 kbit/s,  $Z_O = 50\ \Omega$ , 50% duty cycle,  $t_r \leq 10\text{ ns}$ ,  $t_f \leq 10\text{ ns}$ .

Figure 2. Driver Pulse Skew

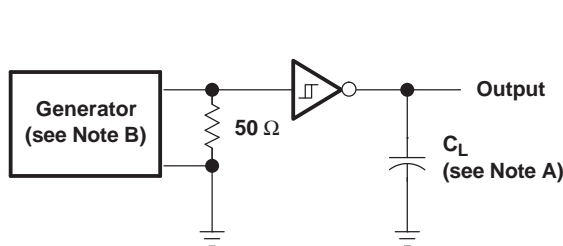

TEST CIRCUIT

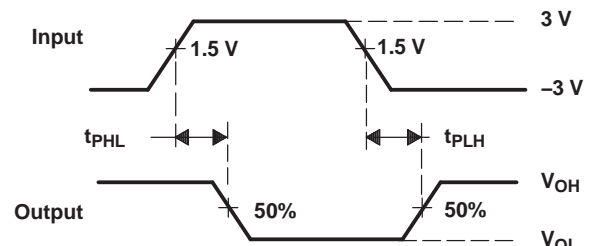

VOLTAGE WAVEFORMS

NOTES: A.  $C_L$  includes probe and jig capacitance.

B. The pulse generator has the following characteristics:  $Z_O = 50\ \Omega$ , 50% duty cycle,  $t_r \leq 10\text{ ns}$ ,  $t_f \leq 10\text{ ns}$ .

Figure 3. Receiver Propagation Delay Times

**APPLICATION INFORMATION**

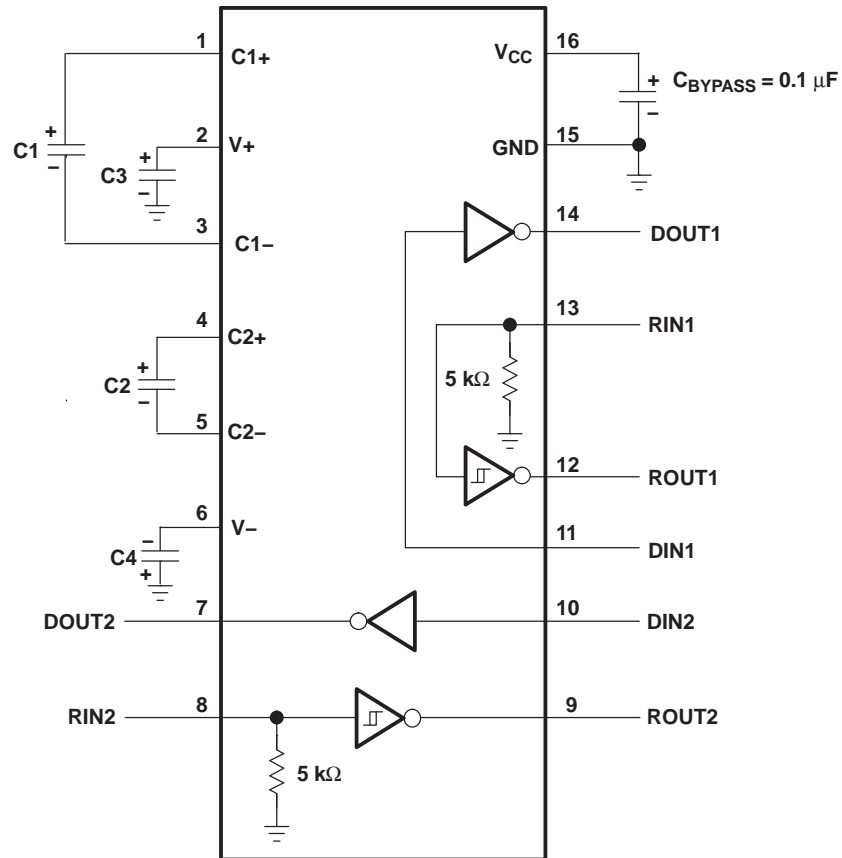

**V<sub>CC</sub> vs CAPACITOR VALUES**

V <sub>CC</sub>	C1	C2, C3, C4
3.3 V $\pm$ 0.3 V	0.1 $\mu$ F	0.1 $\mu$ F
5 V $\pm$ 0.5 V	0.047 $\mu$ F	0.33 $\mu$ F
3 V to 5.5 V	0.1 $\mu$ F	0.47 $\mu$ F

A. C3 can be connected to V<sub>CC</sub> or GND.

**Figure 4. Typical Operating Circuit and Capacitor Values**



**PACKAGING INFORMATION**

Orderable Device	Status (1)	Package Type	Package Drawing	Pins	Package Qty	Eco Plan (2)	Lead finish/ Ball material (6)	MSL Peak Temp (3)	Op Temp (°C)	Device Marking (4/5)	Samples
TRSF3232ECD	ACTIVE	SOIC	D	16	40	Green (RoHS & no Sb/Br)	NIPDAU	Level-1-260C-UNLIM	0 to 70	TRSF3232EC	<a href="#">Samples</a>
TRSF3232ECDB	ACTIVE	SSOP	DB	16	80	Green (RoHS & no Sb/Br)	NIPDAU	Level-1-260C-UNLIM	0 to 70	RT32EC	<a href="#">Samples</a>
TRSF3232ECDBR	ACTIVE	SSOP	DB	16	2000	Green (RoHS & no Sb/Br)	NIPDAU	Level-1-260C-UNLIM	0 to 70	RT32EC	<a href="#">Samples</a>
TRSF3232ECDBRG4	ACTIVE	SSOP	DB	16	2000	Green (RoHS & no Sb/Br)	NIPDAU	Level-1-260C-UNLIM	0 to 70	RT32EC	<a href="#">Samples</a>
TRSF3232ECDR	ACTIVE	SOIC	D	16	2500	Green (RoHS & no Sb/Br)	NIPDAU	Level-1-260C-UNLIM	0 to 70	TRSF3232EC	<a href="#">Samples</a>
TRSF3232ECDWR	ACTIVE	SOIC	DW	16	2000	Green (RoHS & no Sb/Br)	NIPDAU	Level-1-260C-UNLIM	0 to 70	TRSF3232EC	<a href="#">Samples</a>
TRSF3232ECPWR	ACTIVE	TSSOP	PW	16	2000	Green (RoHS & no Sb/Br)	NIPDAU	Level-1-260C-UNLIM	0 to 70	RT32EC	<a href="#">Samples</a>
TRSF3232EID	ACTIVE	SOIC	D	16	40	Green (RoHS & no Sb/Br)	NIPDAU	Level-1-260C-UNLIM	-40 to 85	TRSF3232EI	<a href="#">Samples</a>
TRSF3232EIDBR	ACTIVE	SSOP	DB	16	2000	Green (RoHS & no Sb/Br)	NIPDAU	Level-1-260C-UNLIM	-40 to 85	RT32EI	<a href="#">Samples</a>
TRSF3232EIDR	ACTIVE	SOIC	D	16	2500	Green (RoHS & no Sb/Br)	NIPDAU	Level-1-260C-UNLIM	-40 to 85	TRSF3232EI	<a href="#">Samples</a>
TRSF3232EIDW	ACTIVE	SOIC	DW	16	40	Green (RoHS & no Sb/Br)	NIPDAU	Level-1-260C-UNLIM	-40 to 85	TRSF3232EI	<a href="#">Samples</a>
TRSF3232EIDWR	ACTIVE	SOIC	DW	16	2000	Green (RoHS & no Sb/Br)	NIPDAU	Level-1-260C-UNLIM	-40 to 85	TRSF3232EI	<a href="#">Samples</a>
TRSF3232EIPW	ACTIVE	TSSOP	PW	16	90	Green (RoHS & no Sb/Br)	NIPDAU	Level-1-260C-UNLIM	-40 to 85	RT32EI	<a href="#">Samples</a>
TRSF3232EIPWR	ACTIVE	TSSOP	PW	16	2000	Green (RoHS & no Sb/Br)	NIPDAU	Level-1-260C-UNLIM	-40 to 85	RT32EI	<a href="#">Samples</a>
TRSF3232EIRGTR	PREVIEW	VQFN	RGT	16	3000	TBD	Call TI	Call TI	-40 to 85		

(1) The marketing status values are defined as follows:

**ACTIVE:** Product device recommended for new designs.

**LIFEBUY:** TI has announced that the device will be discontinued, and a lifetime-buy period is in effect.

**NRND:** Not recommended for new designs. Device is in production to support existing customers, but TI does not recommend using this part in a new design.

---

**PREVIEW:** Device has been announced but is not in production. Samples may or may not be available.

**OBSOLETE:** TI has discontinued the production of the device.

<sup>(2)</sup> **RoHS:** TI defines "RoHS" to mean semiconductor products that are compliant with the current EU RoHS requirements for all 10 RoHS substances, including the requirement that RoHS substance do not exceed 0.1% by weight in homogeneous materials. Where designed to be soldered at high temperatures, "RoHS" products are suitable for use in specified lead-free processes. TI may reference these types of products as "Pb-Free".

**RoHS Exempt:** TI defines "RoHS Exempt" to mean products that contain lead but are compliant with EU RoHS pursuant to a specific EU RoHS exemption.

**Green:** TI defines "Green" to mean the content of Chlorine (Cl) and Bromine (Br) based flame retardants meet JS709B low halogen requirements of  $\leq 1000$ ppm threshold. Antimony trioxide based flame retardants must also meet the  $\leq 1000$ ppm threshold requirement.

<sup>(3)</sup> MSL, Peak Temp. - The Moisture Sensitivity Level rating according to the JEDEC industry standard classifications, and peak solder temperature.

<sup>(4)</sup> There may be additional marking, which relates to the logo, the lot trace code information, or the environmental category on the device.

<sup>(5)</sup> Multiple Device Markings will be inside parentheses. Only one Device Marking contained in parentheses and separated by a "~" will appear on a device. If a line is indented then it is a continuation of the previous line and the two combined represent the entire Device Marking for that device.

<sup>(6)</sup> Lead finish/Ball material - Orderable Devices may have multiple material finish options. Finish options are separated by a vertical ruled line. Lead finish/Ball material values may wrap to two lines if the finish value exceeds the maximum column width.

**Important Information and Disclaimer:** The information provided on this page represents TI's knowledge and belief as of the date that it is provided. TI bases its knowledge and belief on information provided by third parties, and makes no representation or warranty as to the accuracy of such information. Efforts are underway to better integrate information from third parties. TI has taken and continues to take reasonable steps to provide representative and accurate information but may not have conducted destructive testing or chemical analysis on incoming materials and chemicals. TI and TI suppliers consider certain information to be proprietary, and thus CAS numbers and other limited information may not be available for release.

In no event shall TI's liability arising out of such information exceed the total purchase price of the TI part(s) at issue in this document sold by TI to Customer on an annual basis.

**TAPE AND REEL INFORMATION**

**QUADRANT ASSIGNMENTS FOR PIN 1 ORIENTATION IN TAPE**

\*All dimensions are nominal

Device	Package Type	Package Drawing	Pins	SPQ	Reel Diameter (mm)	Reel Width W1 (mm)	A0 (mm)	B0 (mm)	K0 (mm)	P1 (mm)	W (mm)	Pin1 Quadrant
TRSF3232ECDR	SOIC	D	16	2500	330.0	16.4	6.5	10.3	2.1	8.0	16.0	Q1
TRSF3232ECDWR	SOIC	DW	16	2000	330.0	16.4	10.75	10.7	2.7	12.0	16.0	Q1
TRSF3232ECPWR	TSSOP	PW	16	2000	330.0	12.4	6.9	5.6	1.6	8.0	12.0	Q1
TRSF3232EIDR	SOIC	D	16	2500	330.0	16.4	6.5	10.3	2.1	8.0	16.0	Q1
TRSF3232EIDWR	SOIC	DW	16	2000	330.0	16.4	10.75	10.7	2.7	12.0	16.0	Q1
TRSF3232EIPWR	TSSOP	PW	16	2000	330.0	12.4	6.9	5.6	1.6	8.0	12.0	Q1

**TAPE AND REEL BOX DIMENSIONS**

\*All dimensions are nominal

Device	Package Type	Package Drawing	Pins	SPQ	Length (mm)	Width (mm)	Height (mm)
TRSF3232ECDR	SOIC	D	16	2500	367.0	367.0	38.0
TRSF3232ECDWR	SOIC	DW	16	2000	350.0	350.0	43.0
TRSF3232ECPWR	TSSOP	PW	16	2000	367.0	367.0	35.0
TRSF3232EIDR	SOIC	D	16	2500	367.0	367.0	38.0
TRSF3232EIDWR	SOIC	DW	16	2000	350.0	350.0	43.0
TRSF3232EIPWR	TSSOP	PW	16	2000	367.0	367.0	35.0

## GENERIC PACKAGE VIEW

**DW 16**

**SOIC - 2.65 mm max height**

7.5 x 10.3, 1.27 mm pitch

SMALL OUTLINE INTEGRATED CIRCUIT

This image is a representation of the package family, actual package may vary.  
Refer to the product data sheet for package details.



4224780/A



DW0016A

# PACKAGE OUTLINE

SOIC - 2.65 mm max height

SOIC

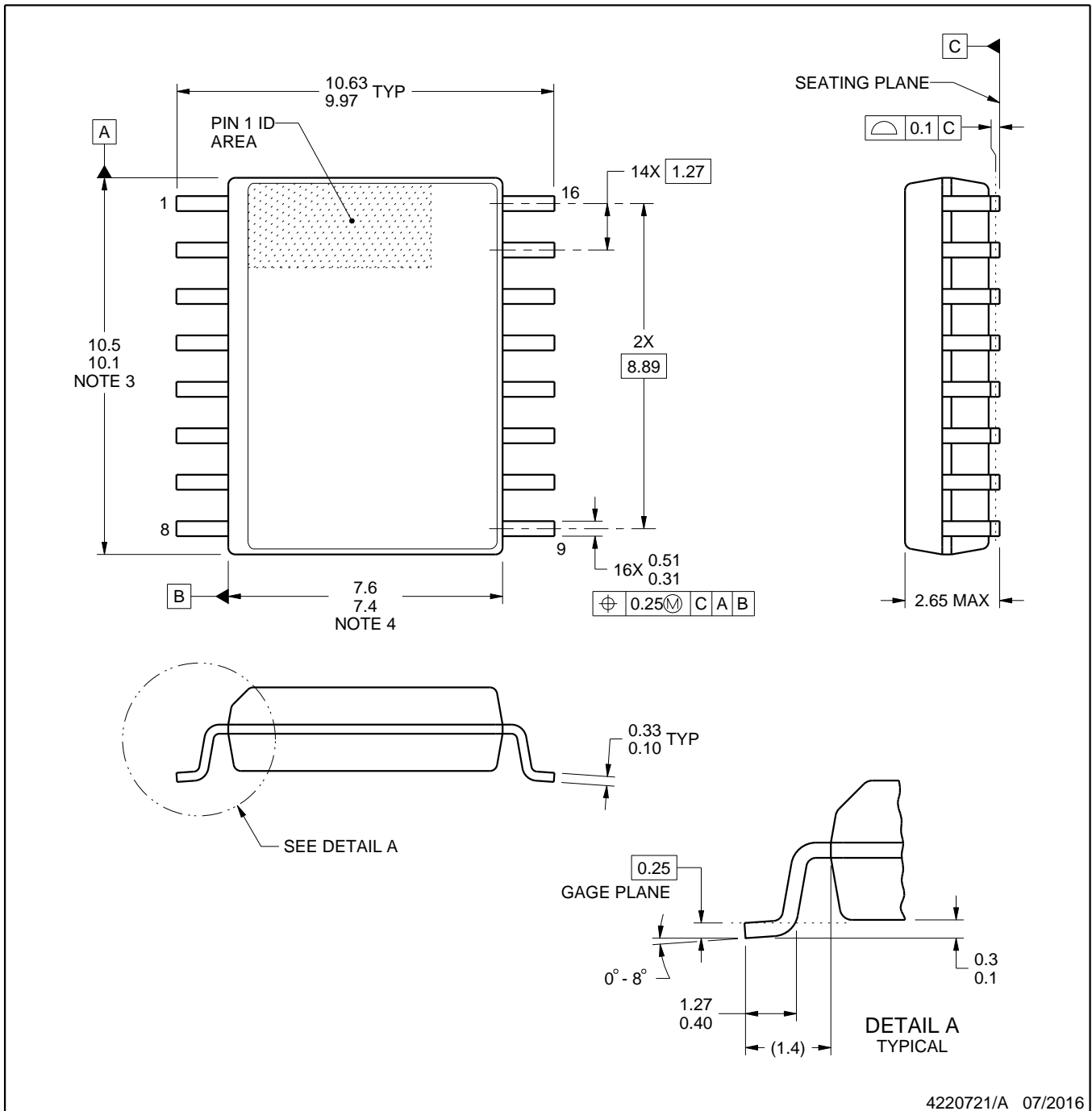

4220721/A 07/2016

### NOTES:

1. All linear dimensions are in millimeters. Dimensions in parenthesis are for reference only. Dimensioning and tolerancing per ASME Y14.5M.
2. This drawing is subject to change without notice.
3. This dimension does not include mold flash, protrusions, or gate burrs. Mold flash, protrusions, or gate burrs shall not exceed 0.15 mm, per side.
4. This dimension does not include interlead flash. Interlead flash shall not exceed 0.25 mm, per side.
5. Reference JEDEC registration MS-013.

# EXAMPLE BOARD LAYOUT

DW0016A

SOIC - 2.65 mm max height

SOIC



LAND PATTERN EXAMPLE  
SCALE:7X



SOLDER MASK DETAILS

4220721/A 07/2016

NOTES: (continued)

6. Publication IPC-7351 may have alternate designs.

7. Solder mask tolerances between and around signal pads can vary based on board fabrication site.

# EXAMPLE STENCIL DESIGN

DW0016A

SOIC - 2.65 mm max height

SOIC



SOLDER PASTE EXAMPLE  
BASED ON 0.125 mm THICK STENCIL  
SCALE:7X

4220721/A 07/2016

NOTES: (continued)

8. Laser cutting apertures with trapezoidal walls and rounded corners may offer better paste release. IPC-7525 may have alternate design recommendations.
9. Board assembly site may have different recommendations for stencil design.



DB (R-PDSO-G\*\*)

PLASTIC SMALL-OUTLINE

28 PINS SHOWN

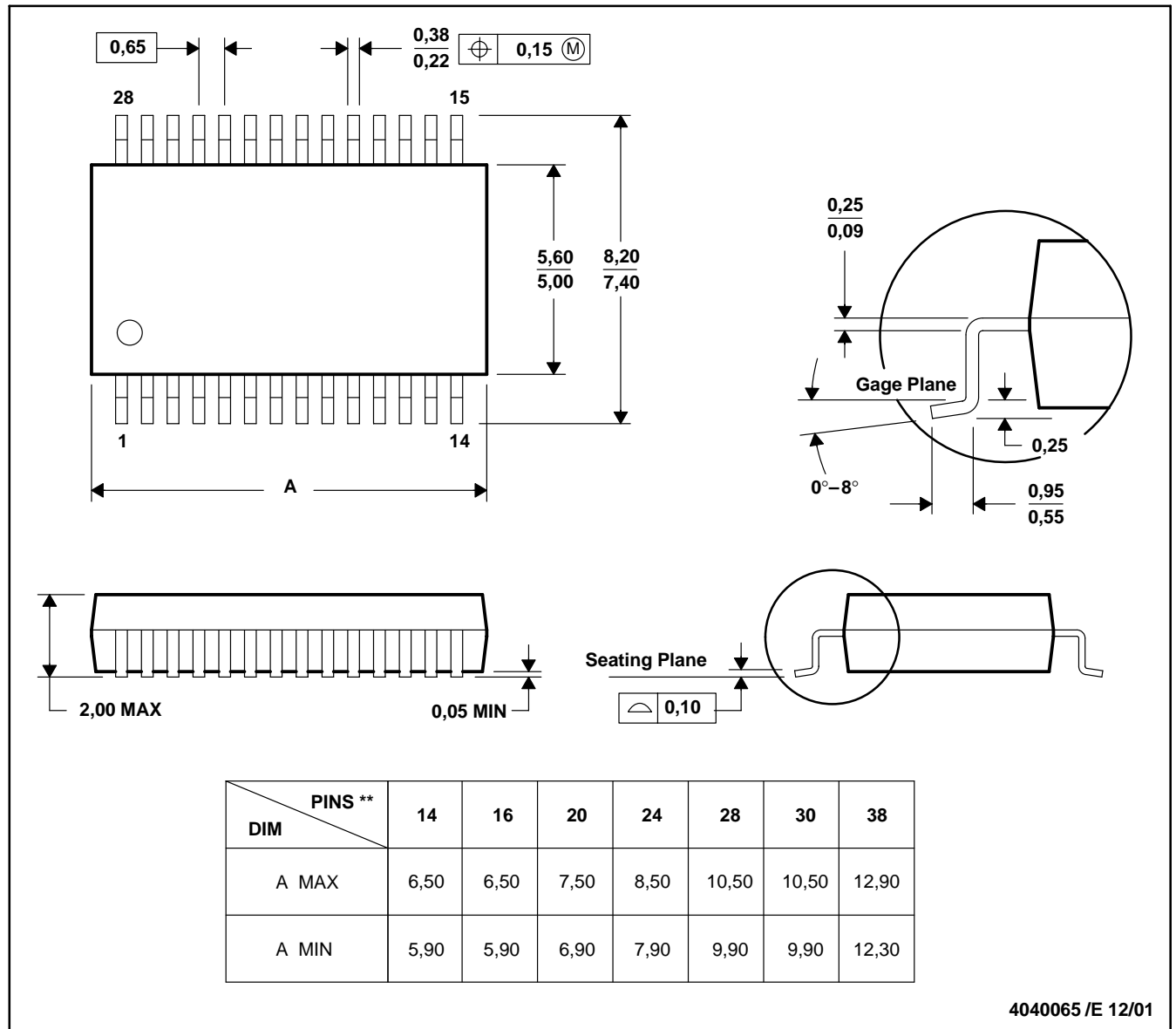

- NOTES: A. All linear dimensions are in millimeters.  
 B. This drawing is subject to change without notice.  
 C. Body dimensions do not include mold flash or protrusion not to exceed 0,15.  
 D. Falls within JEDEC MO-150

D (R-PDSO-G16)

PLASTIC SMALL OUTLINE



- NOTES:
- A. All linear dimensions are in inches (millimeters).
  - B. This drawing is subject to change without notice.
  - C. Body length does not include mold flash, protrusions, or gate burrs. Mold flash, protrusions, or gate burrs shall not exceed 0.006 (0,15) each side.
  - D. Body width does not include interlead flash. Interlead flash shall not exceed 0.017 (0,43) each side.
  - E. Reference JEDEC MS-012 variation AC.



4220204/A 02/2017

NOTES:

1. All linear dimensions are in millimeters. Any dimensions in parenthesis are for reference only. Dimensioning and tolerancing per ASME Y14.5M.
2. This drawing is subject to change without notice.
3. This dimension does not include mold flash, protrusions, or gate burrs. Mold flash, protrusions, or gate burrs shall not exceed 0.15 mm per side.
4. This dimension does not include interlead flash. Interlead flash shall not exceed 0.25 mm per side.
5. Reference JEDEC registration MO-153.

# EXAMPLE BOARD LAYOUT

PW0016A

TSSOP - 1.2 mm max height

SMALL OUTLINE PACKAGE



LAND PATTERN EXAMPLE  
EXPOSED METAL SHOWN  
SCALE: 10X



SOLDER MASK DETAILS

4220204/A 02/2017

NOTES: (continued)

- 6. Publication IPC-7351 may have alternate designs.
- 7. Solder mask tolerances between and around signal pads can vary based on board fabrication site.

# EXAMPLE STENCIL DESIGN

PW0016A

TSSOP - 1.2 mm max height

SMALL OUTLINE PACKAGE



SOLDER PASTE EXAMPLE  
BASED ON 0.125 mm THICK STENCIL  
SCALE: 10X

4220204/A 02/2017

NOTES: (continued)

- 8. Laser cutting apertures with trapezoidal walls and rounded corners may offer better paste release. IPC-7525 may have alternate design recommendations.
- 9. Board assembly site may have different recommendations for stencil design.

## IMPORTANT NOTICE AND DISCLAIMER

TI PROVIDES TECHNICAL AND RELIABILITY DATA (INCLUDING DATASHEETS), DESIGN RESOURCES (INCLUDING REFERENCE DESIGNS), APPLICATION OR OTHER DESIGN ADVICE, WEB TOOLS, SAFETY INFORMATION, AND OTHER RESOURCES "AS IS" AND WITH ALL FAULTS, AND DISCLAIMS ALL WARRANTIES, EXPRESS AND IMPLIED, INCLUDING WITHOUT LIMITATION ANY IMPLIED WARRANTIES OF MERCHANTABILITY, FITNESS FOR A PARTICULAR PURPOSE OR NON-INFRINGEMENT OF THIRD PARTY INTELLECTUAL PROPERTY RIGHTS.

These resources are intended for skilled developers designing with TI products. You are solely responsible for (1) selecting the appropriate TI products for your application, (2) designing, validating and testing your application, and (3) ensuring your application meets applicable standards, and any other safety, security, or other requirements. These resources are subject to change without notice. TI grants you permission to use these resources only for development of an application that uses the TI products described in the resource. Other reproduction and display of these resources is prohibited. No license is granted to any other TI intellectual property right or to any third party intellectual property right. TI disclaims responsibility for, and you will fully indemnify TI and its representatives against, any claims, damages, costs, losses, and liabilities arising out of your use of these resources.

TI's products are provided subject to TI's Terms of Sale ([www.ti.com/legal/termsofsale.html](http://www.ti.com/legal/termsofsale.html)) or other applicable terms available either on [ti.com](http://ti.com) or provided in conjunction with such TI products. TI's provision of these resources does not expand or otherwise alter TI's applicable warranties or warranty disclaimers for TI products.

Mailing Address: Texas Instruments, Post Office Box 655303, Dallas, Texas 75265  
Copyright © 2020, Texas Instruments Incorporated