

TPSM5D1806 4.5-V to 16-V Input, Dual 6-A / Single 12-A Output Power Module

1 Features

- Independent dual 6-A outputs
- Parallel single 12-A output
- Output voltage range: 0.5 V to 5.5 V
- 0.5-V, $\pm 1\%$ voltage reference accuracy over temperature range
- Frequency synchronization with phase delay
- Independent enable and power good for each output
- Start-up into pre-biased output
- UV and OV power good
- Selectable switching frequency options: 500 kHz, 1.0 MHz, 1.5 MHz, and 2.0 MHz
- Meets EN55011 radiated EMI limits
- Operating junction range: -40°C to $+125^{\circ}\text{C}$
- Operating ambient range: -40°C to $+105^{\circ}\text{C}$
- 8-mm x 5.5-mm x 1.8-mm standard QFN package
- Create a custom design using the TPSM5D1806 With the [WEBENCH® Power Designer](#)

2 Applications

- [Semiconductor test and instrumentation](#)
- [Medical imaging](#)
- [Enterprise switching and storage applications](#)
- [Wired network \(optical transport\)](#)
- [Datacom module \(optical module\)](#)

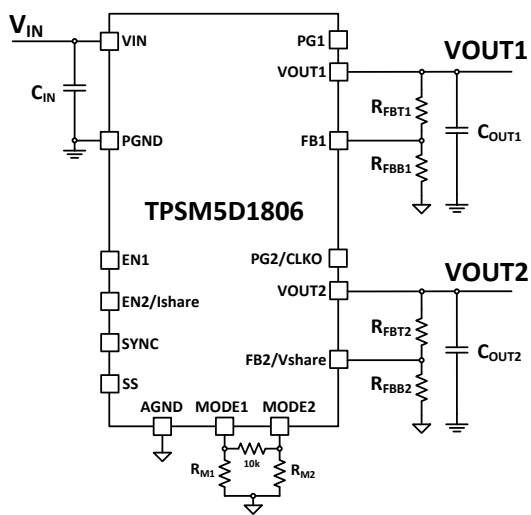

Dual Output Simplified Schematic

3 Description

The TPSM5D1806 dual 6-A output power module is a highly integrated and flexible DC-DC power supply packaged in a compact 8-mm x 5.5-mm x 1.8-mm, QFN package. The input voltage range of 4.5 V to 16 V allows conversion from a wide intermediate bus as well as standard 5-V and 12-V rails. The two 6-A outputs can be configured independently for two separate power rails or combined for a single 2-phase, 12-A output.

The low-profile, 51-pin QFN package with optimal package layout enhances thermal performance. The package footprint has all signal pins accessible from the perimeter and large thermal pads beneath the device for simple layout and easy handling in manufacturing.

The integrated power design eliminates the loop compensation and magnetics part selection from the design process. The device offers independent enable control and power good signal for each output. Switching frequency and phase offsetting can be configured using pin-strapping. The device also offers overcurrent and thermal shutdown protection.

Device Information

DEVICE NUMBER	PACKAGE ⁽¹⁾	BODY SIZE (NOM)
TPSM5D1806	QFN	8 mm x 5.5 mm x 1.8 mm

- (1) For all available packages, see the orderable addendum at the end of the data sheet.

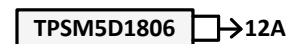
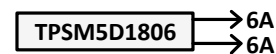
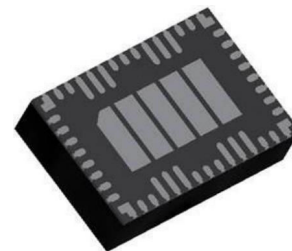

Output Configurations



Table of Contents

1 Features	1	8 Application and Implementation	18
2 Applications	1	8.1 Application Information.....	18
3 Description	1	8.2 Typical Application (Dual Outputs).....	18
4 Revision History	2	9 Power Supply Recommendations	22
5 Pin Configuration and Functions	3	10 Layout	23
6 Specifications	5	10.1 Layout Guidelines.....	23
6.1 Absolute Maximum Ratings	5	10.2 Layout Examples.....	23
6.2 ESD Ratings	5	10.3 Package Specifications.....	24
6.3 Recommended Operating Conditions	5	10.4 EMI.....	24
6.4 Thermal Information	6	11 Device and Documentation Support	26
6.5 Electrical Characteristics	6	11.1 Device Support.....	26
6.6 Typical Characteristics (VIN = 12V).....	8	11.2 Receiving Notification of Documentation Updates..	26
6.7 Typical Characteristics (VIN = 5 V).....	9	11.3 Support Resources.....	26
7 Detailed Description	10	11.4 Trademarks.....	26
7.1 Overview.....	10	11.5 Electrostatic Discharge Caution.....	26
7.2 Functional Block Diagram.....	10	11.6 Glossary.....	26
7.3 Feature Description.....	11	12 Mechanical, Packaging, and Orderable	
7.4 Device Functional Modes.....	17	Information	26

4 Revision History

NOTE: Page numbers for previous revisions may differ from page numbers in the current version.

DATE	REVISION	NOTES
November 2020	*	Initial release

5 Pin Configuration and Functions

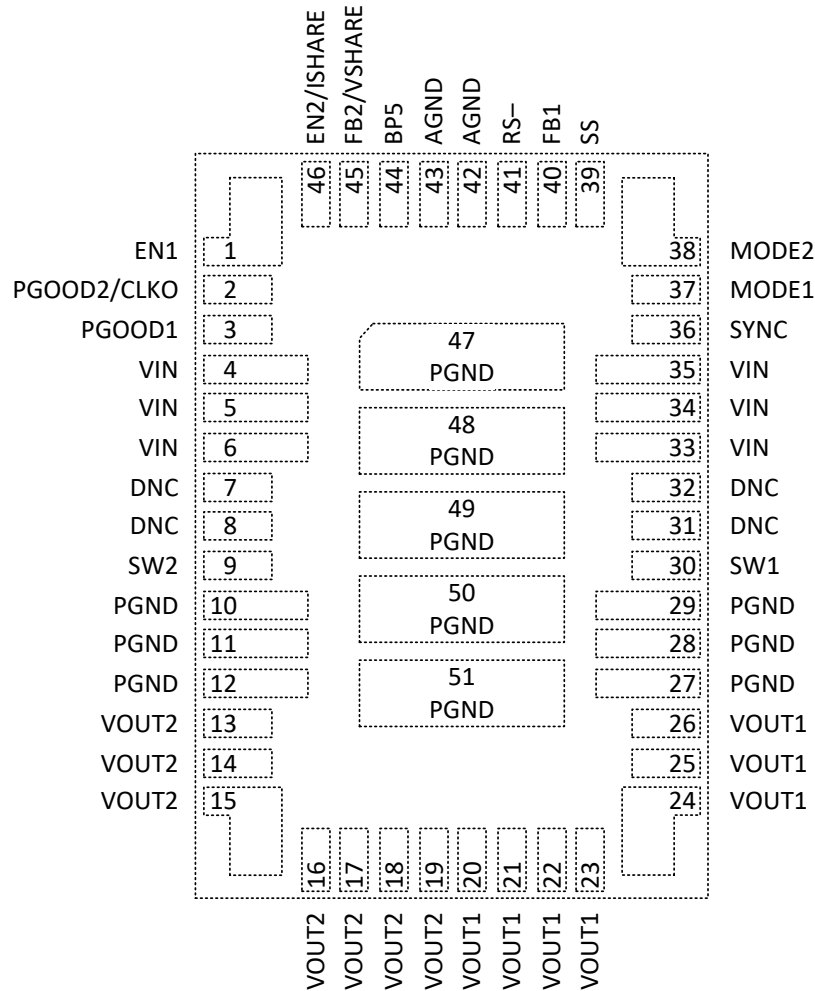

Figure 5-1. 51-Pin, QFN Package (Top View)

Table 5-1. Pin Functions

PIN		TYPE ⁽¹⁾	DESCRIPTION
NAME	NO.		
AGND	42, 43	G	Analog ground for the internal analog control circuit. Connect to PGND at one single point, away from noisy circuitry.
BP5	44	O	Output of the internal 5-V regulator. Bypass this pin with a minimum of 1.5 μ F of effective capacitance to AGND. Can be used as a pullup voltage for PGOOD signals.
DNC	7, 8, 31, 32	-	Do not connect. Do not connect these pins to AGND, PGND, to another DNC pin, or to any other voltage. These pins are connected to internal circuitry. Each pin must be soldered to an isolated pad.
EN1	1	I	Channel 1 Enable input. Float or pull high to enable. Can also be used to externally adjust EN UVLO by connecting a resistor divider between VIN and AGND.
EN2/ISHARE	46	I/O	Multi-function pin: Dual output configuration: Channel 2 Enable input. Float or pull high to enable. Can also be used to externally adjust EN UVLO by connecting resistor divider between VIN and AGND. Parallel output configuration: Current balance node of the internal regulators. Leave this pin open.
FB1	40	I	Channel 1 feedback input. Connect to output voltage of channel 1 with a resistor divider.

Table 5-1. Pin Functions (continued)

PIN		TYPE ⁽¹⁾	DESCRIPTION
NAME	NO.		
FB2/VSHARE	45	I/O	Multi-function pin: Dual output configuration: Channel 2 Feedback input. Connect to output voltage of channel 2 with a resistor divider. Parallel output configuration: The COMP voltage of the internal regulators. Leave this pin open.
MODE1	37	I	Mode setting pin. Programs channel configuration as either dual or parallel outputs and programs channel interleaving using a resistor between MODE1 pin and AGND. A 10-kΩ resistor is required between the MODE1 pin and MODE2 pin.
MODE2	38	I	Mode setting pin. Select from four pre-set switching frequencies using a resistor between MODE2 pin and AGND. A 10-kΩ resistor is required between MODE1 pin and MODE2 pin.
PGND	10, 11, 12, 27, 28, 29, 47, 48, 49, 50, 51	G	Power ground of the device. This is the return current path for the power stage of the device. Connect these pins to the bypass capacitors associated with VIN and VOUT. Connect pads 47, 48, 49, 50, and 51 to the PCB ground planes using multiple vias for optimal thermal performance. All pins must be connected together externally with a copper plane or pour directly under the device.
PGOOD1	3	O	Channel 1 Power Good indicator output. This pin is an open-drain output, which asserts low during any fault condition. When used, a pullup resistor to BP5 or other external supply is required. Leave this pin open if unused.
PGOOD2/CLKO	2	O	Multi-function pin: Dual output configuration: Channel 2 Power Good indicator output. This pin is an open-drain output, which asserts low during any fault condition. When used, a pullup resistor to BP5 or other external supply is required. Leave this pin open if unused. Parallel output configuration: 180° clock output. Leave this pin open if unused.
RS-	41	G	For parallel output applications, this pin functions as remote sense negative input to the differential amplifier. Connect this pin to the point of ground regulation using a kelvin trace. For dual output configurations, this pin should be tied to AGND.
SS	39	I	External Soft Start when configured for parallel output operation. Place a capacitor from SS to AGND to set output voltage rise time. For independent dual channel configurations, leave this pin open.
SW1	30	O	Channel 1 power stage switch node. Can be used to monitor the switch node.
SW2	9	O	Channel 2 power stage switch node. Can be used to monitor the switch node.
SYNC	36	I	Synchronizes to external clock, or the CLKO pin of another device.
VIN	4, 5, 6, 33, 34, 35	I	Power conversion input pins. Pins 4, 5, and 6 are not internally connected to pins 33, 34, and 35. Connection must be made using the PCB VIN plane. Bypass VIN pins with ceramic capacitance to PGND, close to the device.
VOUT1	20, 21, 22, 23, 24, 25, 26	O	Channel 1 output voltage. These pins are connected to the internal output inductor. Connect to the output load. Place external bypass capacitors between these pins and PGND.
VOUT2	13, 14, 15, 16, 17, 18, 19	O	Channel 2 output voltage. These pins are connected to the internal output inductor. Connect to the output load. Place external bypass capacitors between these pins and PGND.

(1) G = Ground, I = Input, O = Output

6 Specifications

6.1 Absolute Maximum Ratings

over operating free-air temperature range (unless otherwise noted)⁽¹⁾

		MIN	MAX	UNIT
Input voltage	VIN	-0.3	18	V
	BP5, EN1, EN2/ISHARE, FB1, FB2/VSHARE, MODE1, MODE2, PGOOD1, PGOOD2/CLKO, SS, SYNC	-0.3	6	V
	RS-, PGND to AGND	-0.3	0.3	V
Output voltage	VOUT1, VOUT2	-0.3	6	V
	SW1, SW2	-0.3	18	
	SW1, SW2 transient (10ns)	-3	20	V
T _J	Operating IC junction temperature	-40	125	°C
T _{stg}	Storage temperature	-40	125	°C
	Peak reflow case temperature		260	°C
	Maximum number of reflows allowed		3	
Mechanical shock	Mil-STD-883D, Method 2002.3, 1 msec, 1/2 sine, mounted		500	G
Mechanical vibration	Mil-STD-883D, Method 2007.2, 20 to 2000 Hz		20	G

- (1) Stresses beyond those listed under *Absolute Maximum Rating* may cause permanent damage to the device. These are stress ratings only, which do not imply functional operation of the device at these or any other conditions beyond those indicated under *Recommended Operating Conditions*. Exposure to absolute-maximum-rated conditions for extended periods may affect device reliability.

6.2 ESD Ratings

			VALUE	UNIT
V _(ESD)	Electrostatic discharge	Human body model (HBM), per ANSI/ESDA/JEDEC JS-001, all pins ⁽¹⁾	± 2500	V
		Charged device model (CDM), per JEDEC specification JESD22-C101, all pins ⁽²⁾	± 1000	

- (1) JEDEC document JEP155 states that 500-V HBM allows safe manufacturing with a standard ESD control process.
(2) JEDEC document JEP157 states that 250-V CDM allows safe manufacturing with a standard ESD control process.

6.3 Recommended Operating Conditions

over operating free-air temperature range (unless otherwise noted)⁽¹⁾

		MIN	NOM	MAX	UNIT
V _{IN}	Input voltage	4.5 ⁽²⁾		16	V
V _{OUT}	Output voltage	0.5		5.5	V
I _{OUT}	Output current per channel, continuous			6	A
V _{EN}	EN voltage	0		5.5	V
V _{PGOOD}	PGOOD pull-up voltage			5.5	V
T _A	Operating ambient temperature	-40		105	°C

- (1) Recommended operating conditions indicate conditions for which the device is intended to be functional, but do not ensure specific performance limits. For ensured specifications, see the *Electrical Characteristics* table.
(2) See [Minimum Input Voltage](#) section for the recommended minimum input voltage at higher output voltages.

6.4 Thermal Information

THERMAL METRIC ⁽¹⁾		TPSM5D1806	UNIT
		RDB (QFN)	
		51 PINS	
$R_{\theta JA}$	Junction-to-ambient thermal resistance ⁽²⁾	13.9	°C/W
Ψ_{JT}	Junction-to-top characterization parameter ⁽³⁾	1.8	°C/W
Ψ_{JB}	Junction-to-board characterization parameter ⁽⁴⁾	9.4	°C/W
T_{SHDN}	Thermal Shutdown Temperature	165	°C
T_{SHDN}	Thermal Shutdown Hysteresis	20	°C

- (1) For more information about thermal metrics, see the [Semiconductor and IC Package Thermal Metrics](#) application report.
- (2) The junction-to-ambient thermal resistance, $R_{\theta JA}$, applies to devices soldered directly to a 100 mm × 100 mm, 6-layer PCB with 2 oz. copper and natural convection cooling. Additional airflow reduces $R_{\theta JA}$.
- (3) The junction-to-top characterization parameter, Ψ_{JT} , estimates the junction temperature, T_J , of a device in a real system, using a procedure described in JE5D51-2A (section 6 and 7). $T_J = \Psi_{JT} \times P_{dis} + T_T$; where P_{dis} is the power dissipated in the device and T_T is the temperature of the top of the device.
- (4) The junction-to-board characterization parameter, Ψ_{JB} , estimates the junction temperature, T_J , of a device in a real system, using a procedure described in JE5D51-2A (sections 6 and 7). $T_J = \Psi_{JB} \times P_{dis} + T_B$; where P_{dis} is the power dissipated in the device and T_B is the temperature of the board 1mm from the device.

6.5 Electrical Characteristics

Limits apply over $T_A = -40^\circ\text{C}$ to $+105^\circ\text{C}$, $V_{IN} = 12\text{ V}$ (unless otherwise noted); Minimum and maximum limits are specified through production test or by design. Typical values represent the most likely parametric norm and are provided for reference only.

PARAMETER		TEST CONDITIONS	MIN	TYP	MAX	UNIT
INPUT VOLTAGE (VIN)						
V_{IN}	Operating input voltage range		4.5 ⁽¹⁾		16	V
UVLO	V_{IN} turn on	V_{IN} increasing	3.5	3.7	3.9	V
	Hysteresis			200		mV
I_Q	Quiescent current	Non-switching, $V_{FB1}, V_{FB2} > 0.5\text{ V}$, $T_A = 25^\circ\text{C}$, EN1 = EN2 = 5 V		2.5		mA
I_{SHDN}	Shutdown supply current	$T_A = 25^\circ\text{C}$, EN1 = EN2 = 0 V		250		μA
INTERNAL LDO (BP5)						
BP5	Regulation voltage	$6\text{ V} \leq V_{IN} \leq 16\text{ V}$, $I_{LOAD} = 70\text{ mA}$	4.8	5.0	5.2	V
FEEDBACK						
$V_{(FB1)}, V_{(FB2)}$	Feedback voltage	$T_J = 25^\circ\text{C}$		0.5		V
	Temperature accuracy	$T_J = -40^\circ\text{C}$ to 125°C	-1		+1	%
	Load Regulation	$T_A = +25^\circ\text{C}$, Over I_{OUT} range		0.01		%
	Line Regulation	$T_A = +25^\circ\text{C}$, $I_{OUT} = 0\text{ A}$, Over V_{IN} range		0.03		%
OUTPUT CURRENT						
I_{OUT}	Output current	Per channel	0		6 ⁽²⁾	A
	Overcurrent threshold source current	DC current	6.8	8.0	9.2	A
	Overcurrent threshold sink current	DC current	-4.2	-3.5	-2.8	A
$I_{SH(acc)}$	Output current sharing accuracy	$I_{OUT} \geq 3\text{ A}$ per channel		15		%
		$I_{OUT} < 3\text{ A}$ per channel		1		A
	OCP Hiccup wait time	Wait time to attempt re-start		7		ms
	OCP Hiccup entry time	Cycles before hiccup		16		cycles

Limits apply over $T_A = -40^\circ\text{C}$ to $+105^\circ\text{C}$, $V_{IN} = 12\text{ V}$ (unless otherwise noted); Minimum and maximum limits are specified through production test or by design. Typical values represent the most likely parametric norm and are provided for reference only.

PARAMETER		TEST CONDITIONS	MIN	TYP	MAX	UNIT
SOFT START						
t_{SS}	Default soft-start time	Time from switching to PGOOD high without C_{SS}		1		ms
I_{SS}	Soft-start charge current	$T_{SS} \leq 50\text{ ms}$, $C_{SS} < 0.3\text{ }\mu\text{F}$		2		μA
R_{SS}	Soft-start discharge resistance			600		Ω
ENABLE (EN)						
V_{EN}	Enable threshold voltage	EN rising		1.2	1.3	V
		EN falling	1	1.1		V
	Hysteresis on Enable			100		mV
	Enable pull-up current	EN floating		1.4		μA
	Enable to start switching time	$V_{IN} \geq 4.5\text{ V}$, toggle EN	0.5	0.75	1	ms
SWITCH NODE (SW)						
	SW1, SW2 Discharge FET			27		Ω
	SW1, SW2 minimum on time			30		ns
	SW1, SW2 minimum off time			100	150	ns
SWITCHING FREQUENCY						
	fsw1		450	500	550	kHz
	fsw2		900	1000	1100	kHz
	fsw3		1350	1500	1650	kHz
	fsw4		1800	2000	2200	kHz
SYNCHRONIZATION (SYNC)						
$V_{IH(\text{SYNC})}$	High-level input		2			V
$V_{IL(\text{sync})}$	Low-level input				0.6	V
	Input duty cycle		20		80	%
	Sync frequency vs. internal oscillator setting		-20		+20	%
CLOCK OUTPUT (CLKO)						
$V_{OH(\text{CLKO})}$	High-level output	$I_O = 20\text{ }\mu\text{A}$	2.2			V
$V_{OL(\text{CLKO})}$	Low-level output	$I_O = 20\text{ }\mu\text{A}$			0.4	V
	Pulsewidth output			80		ns
POWER GOOD WARNING (PGOOD1, PGOOD2)						
PGOOD	PGOOD thresholds	V_{FB1} , V_{FB2} falling (warning)	87	90	93	%
		V_{FB1} , V_{FB2} rising (good)	90	93	96	%
		V_{FB1} , V_{FB2} falling (good)	104	107	110	%
		V_{FB1} , V_{FB2} rising (warning)	107	110	113	%
	PGOOD leakage current	$V_{PGOOD} = 5.5\text{ V}$			1	μA
	PGOOD sink current	$BP5 = 5\text{ V}$, $V(\text{PGOOD1}/2) \leq 0.4\text{ V}$			6	mA
	Minimum V_{IN} for asserted output	$V_{PGOOD} \leq 0.4\text{ V}$			1.5	V
OUTPUT UNDERVOLTAGE AND OVERVOLTAGE FAULT PROTECTION						
	OV fault threshold	V_{FB1} , V_{FB2} rising (fault)		120		%
	UV fault threshold	V_{FB1} , V_{FB2} falling (fault)		80		%

- See [Section 7.3.3](#) for the recommended minimum input voltage at higher output voltages.
- See Safe Operating Area plots in the *Typical Characteristics* sections of the datasheet.

6.6 Typical Characteristics (VIN = 12V)

T_A = 25°C, unless otherwise noted.

ADVANCE INFORMATION

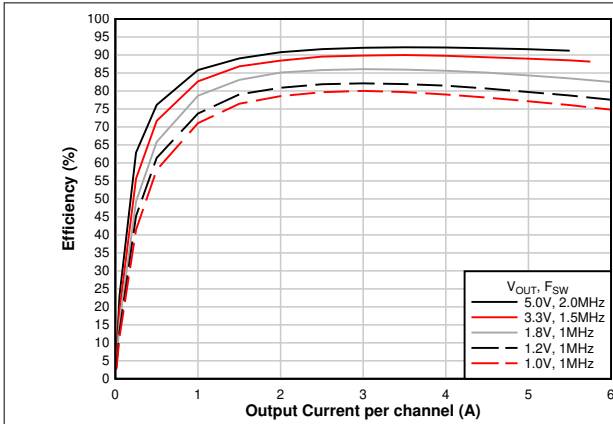

Figure 6-1. Efficiency vs Output Current

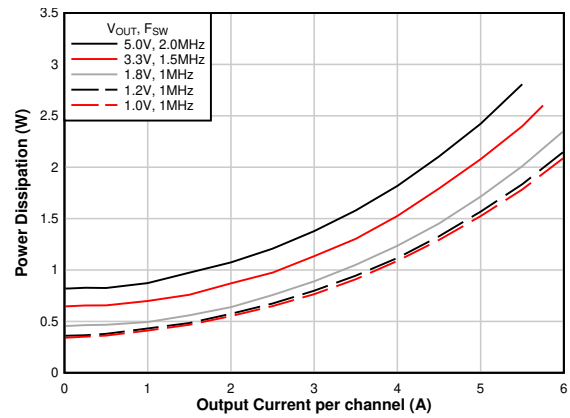
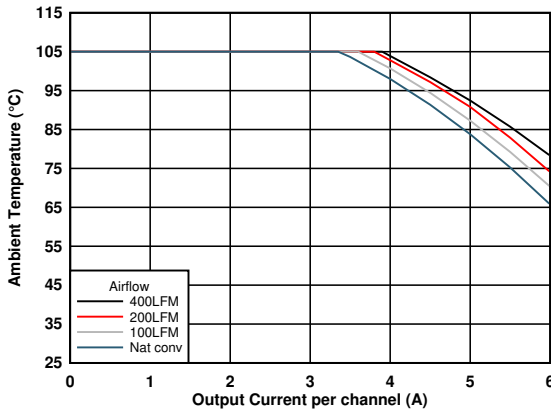
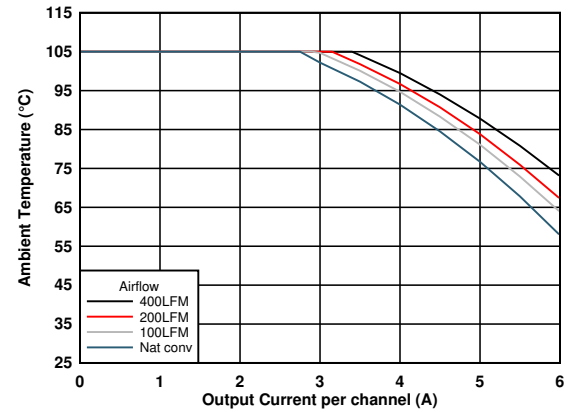

Figure 6-2. Power Dissipation vs Output Current



F_{sw} = 1.0 MHz, Dual 1.2-V Outputs, IOUT1 = IOUT2

Figure 6-3. Safe Operating Area (VOUT = 1.2 V)



F_{sw} = 1.0 MHz, Dual 1.8-V Outputs, IOUT1 = IOUT2

Figure 6-4. Safe Operating Area (VOUT = 1.8 V)

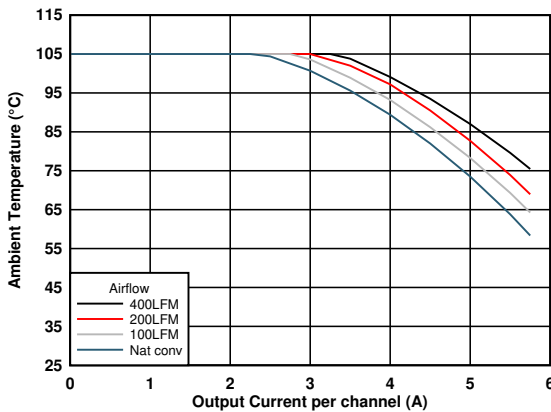

F_{sw} = 1.5 MHz, Dual 3.3-V Outputs, IOUT1 = IOUT2

Figure 6-5. Safe Operating Area (VOUT = 3.3 V)

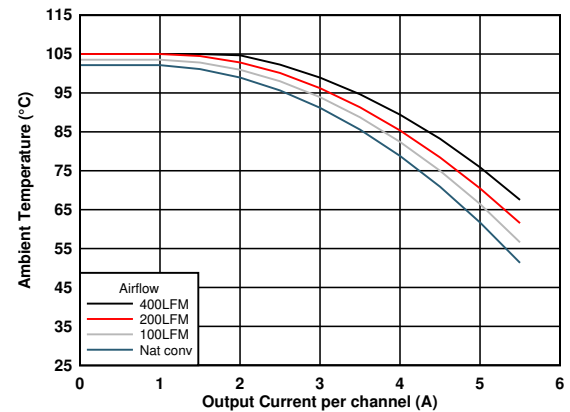

F_{sw} = 2.0 MHz, Dual 5-V Outputs, IOUT1 = IOUT2

Figure 6-6. Safe Operating Area (VOUT = 5 V)

6.7 Typical Characteristics (VIN = 5 V)

T_A = 25°C unless otherwise noted.

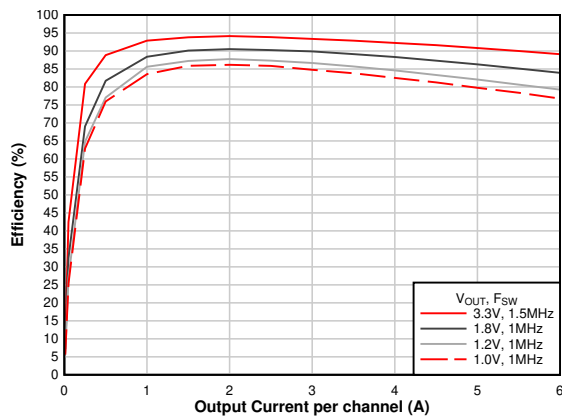

Figure 6-7. Efficiency vs Output Current

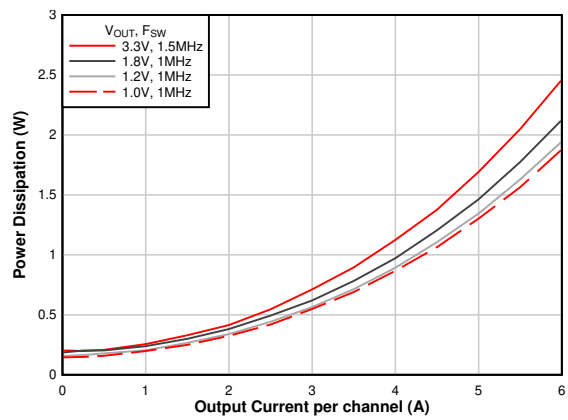
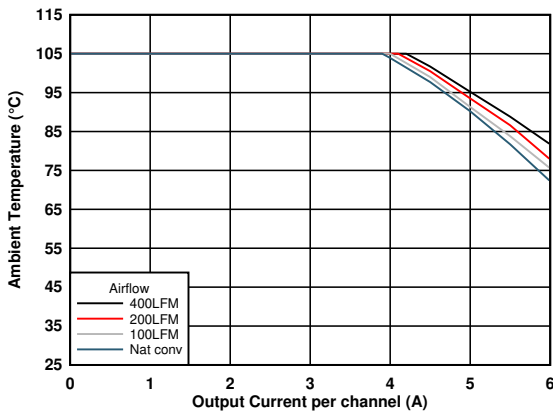
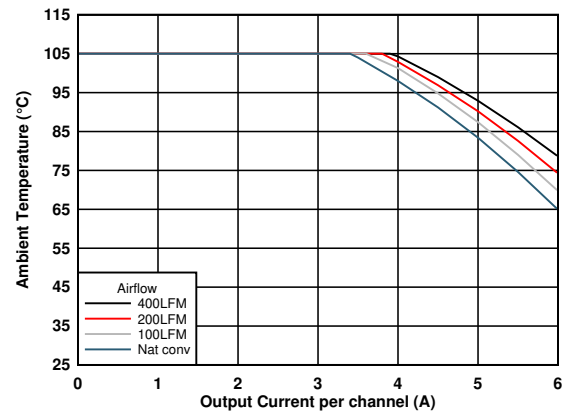

Figure 6-8. Power Dissipation vs Output Current



Fsw = 1.0 MHz Dual 1.2-V Outputs IOUT1 = IOUT2

Figure 6-9. Safe Operating Area (VOUT = 1.2 V)



Fsw = 1.0 MHz Dual 1.8-V Outputs IOUT1 = IOUT2

Figure 6-10. Safe Operating Area (VOUT = 1.8 V)

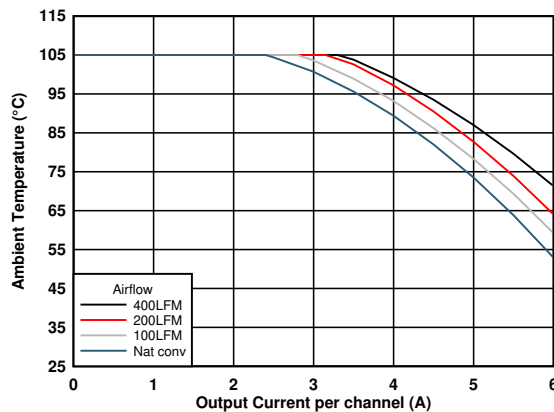

Fsw = 1.5 MHz Dual 3.3-V Outputs IOUT1 = IOUT2

Figure 6-11. Safe Operating Area (VOUT = 3.3 V)

7 Detailed Description

7.1 Overview

The TPSM5D1806 device is a dual output, step-down DC-DC power module with 4.5-V to 16-V input voltage range. Each device has two output channels and is capable of delivering up to 6-A of load current per channel. The device features exceptional efficiency and thermal performance in a very small solution size. The device is configurable as two independent 6-A outputs or a single 2-phase output to deliver up to 12 A. The TPSM5D1806 uses a fixed frequency, proprietary advanced current mode control architecture. The device operates in forced-PWM (FPWM) operation to maintain constant switching frequency over the load range. The device is internally compensated, which reduces design time and requires fewer external components. The switching frequency and the phase operation are configured using pin strapping. The MODE1 pin sets the phase operation. Table 7-3 shows the resistor values that are required to set the phase operation and the correct phase offset. The switching frequency can be selected from pre-set values of 500 kHz, 1.0 MHz, 1.5 MHz, and 2.0 MHz through pin-strapping on MODE2 pin. The TPSM5D1806 is also capable of synchronization to an external clock. The four switching frequency options allows the device to meet a wide range of design requirements. The module also features a power-good (PGOOD) flag for each channel, precision enable for each channel, internal or adjustable soft-start rate, and start-up into pre-bias voltage. The device has a pinout designed for simple, optimum PCB layout, low EMI, and excellent thermal performance.

7.2 Functional Block Diagram

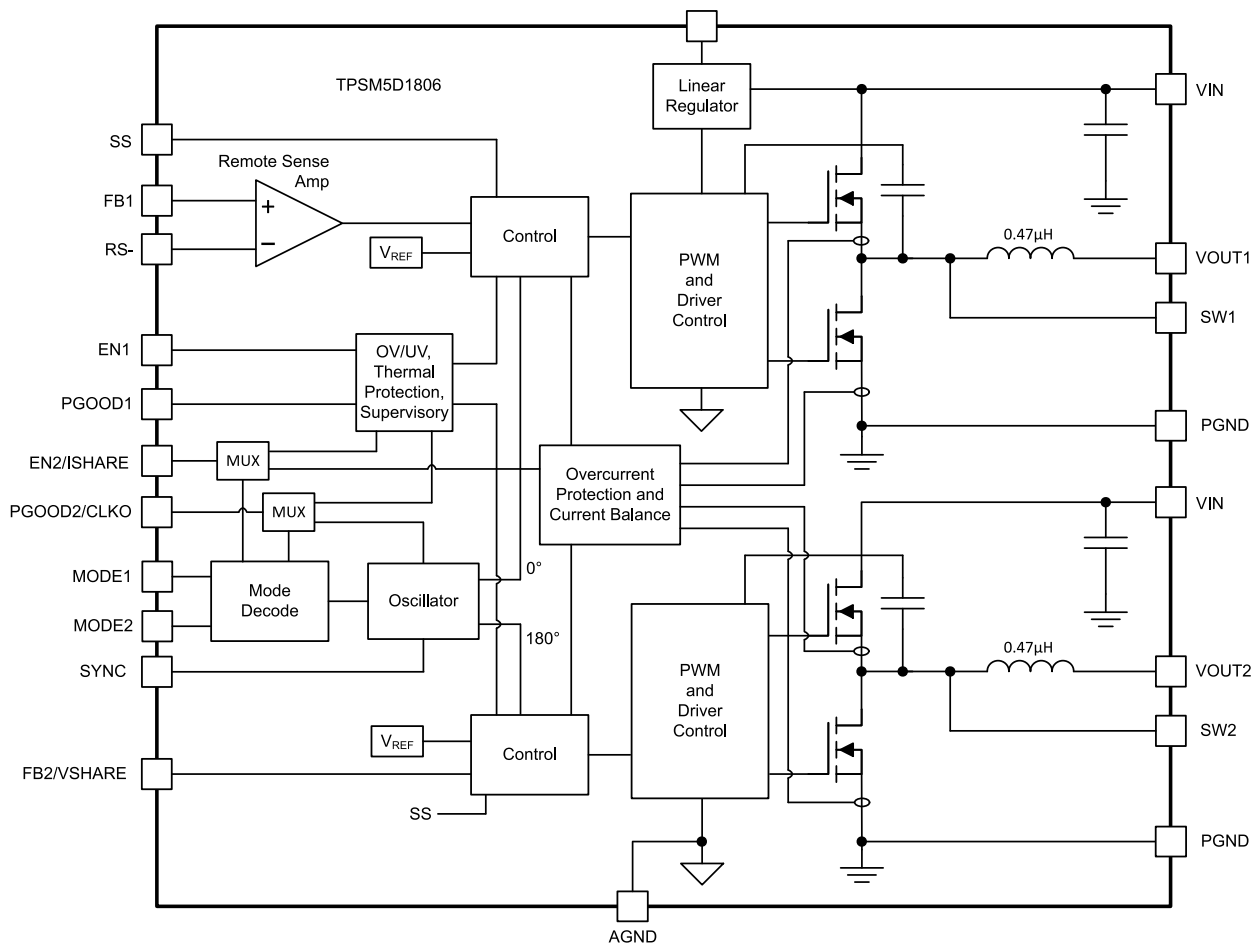

7.3 Feature Description

7.3.1 Adjustable Output Voltage

When operating the TPSM5D1806 as a dual output device, the two output voltages (VOUT1 and VOUT2) are set using resistor dividers between the output voltages and AGND with the mid-point of the resistor divider connecting to the corresponding feedback pin (FB1 and FB2). See [Figure 7-5](#).

Select a bottom feedback resistor of 10 kΩ and calculate the value for the top feedback resistor (R_{FBT}) using the following equation. It is recommended to use divider resistors with 1% tolerance or better, and with temperature coefficient of 100 ppm or lower.

$$R_{FBT} = 20 \times (V_{OUT} - 0.5) \text{ (k}\Omega\text{)} \quad (1)$$

When connecting the two outputs of the TPSM5D1806 for current sharing, the output voltage is set using only a single feedback divider connected to FB1. The FB pin of the second channel, FB2, should be left floating as shown in [Figure 7-2](#). Use [Equation 1](#) to calculate the R_{FBT}.

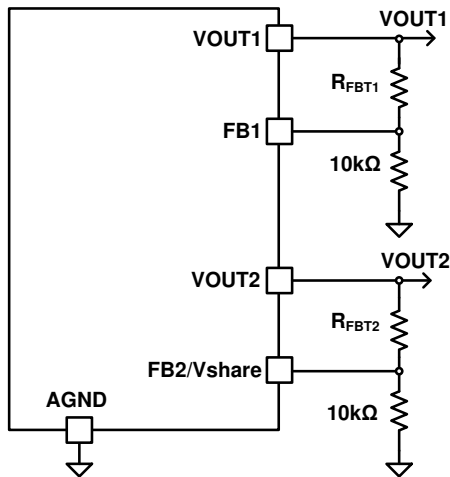

Figure 7-1. Single Device, Dual Output

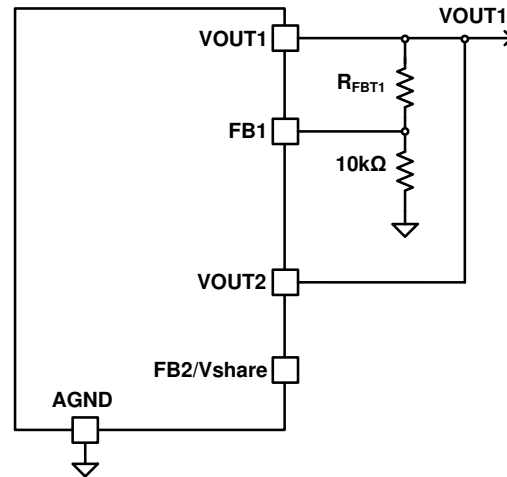

Figure 7-2. Single Device, Current Sharing

7.3.2 Frequency Selection

The TPSM5D1806 can be set to one of four switching frequencies; 500 kHz, 1.0 MHz, 1.5 MHz, or 2.0 MHz. The switching frequency is set using the MODE2 pin on the device. When setting the switching frequency, both channels of the device are set to the same frequency. Not all input voltage and output voltage combinations can operate at all switching frequencies; check [Table 7-1](#) for allowable switching frequencies. Select the appropriate resistor from [Table 7-4](#) to set the switching frequency.

7.3.2.1 Synchronization

The TPSM5D1806 can also be synchronized to an external clock that is within ±20% of the switching frequency set by the MODE2 pin. The external clock signal can be applied to the SYNC pin before or after powering up. When the device is synchronized to an external clock signal, if the clock signal is removed, the device transitions to an intermediate frequency which is 70% of the programmed frequency for five clock cycles. After five clock cycles, the device transitions to the switching frequency set by the MODE2 pin.

7.3.2.2 Allowable Switching Frequency

The TPSM5D1806 can be operated over a wide input voltage range, with a wide output voltage setting range and at four selectable switching frequencies. However, not all input voltage, output voltage and switching frequency combinations can be achieved due to timing and current limitations.

When setting the switching frequency, both channels of the device are set to the same frequency. When operating in dual output configuration, make sure that both channels can be operated at the desired switching frequency by referencing [Table 7-1](#).

Table 7-1. Allowable Switching Frequency

MAXIMUM OUTPUT CURRENT PER CHANNEL	SWITCHING FREQUENCY (kHz)	VIN = 5 V		VIN = 12 V	
		VOUT RANGE		VOUT RANGE	
		MIN	MAX	MIN	MAX
6 A	500	0.5	0.5	0.5	0.8
	1000	0.5	1.3	0.7	1.9
	1500	0.5	3.4	0.9	3.0
	2000	0.5	3.1	1.2	4.1
5.5 A	500	0.5	0.8	0.5	1.0
	1000	0.5	3.3	0.6	2.4
	1500	0.5	3.5	0.9	5.5
	2000	0.5	3.1	1.1	5.5
≤ 5 A	500	0.5	1.2	0.5	1.1
	1000	0.5	3.3	0.6	2.8
	1500	0.5	3.5	0.9	5.5
	2000	0.5	3.1	1.1	5.5

7.3.3 Minimum and Maximum Input Voltage

The minimum input voltage of the TPSM5D1806 is 4.5 V, however, the minimum input voltage increases at higher output voltages. The following images plot the minimum required input voltage for each of the allowable switching frequencies across the output voltage range. The 500 kHz and 1.0 MHz plots are limited to correspond to [Table 7-1](#). It is recommended to control the turn ON and turn OFF of the device at an input voltage greater than the minimum shown in [Figure 7-3](#) using a resistor divider on the EN1 (EN2) pin, between VIN and AGND (see [Section 7.3.8](#)).

Additionally, the maximum input voltage of the TPSM5D1806 is 16 V, however, the maximum input voltage decreases at lower output voltages and higher switching frequencies. See [Figure 7-4](#) for maximum allowable input voltage for each of the allowable switching frequencies across the output voltage range.

ADVANCE INFORMATION

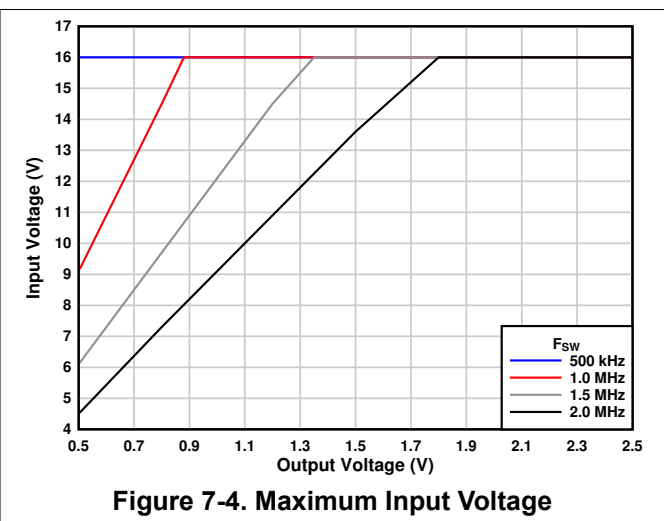
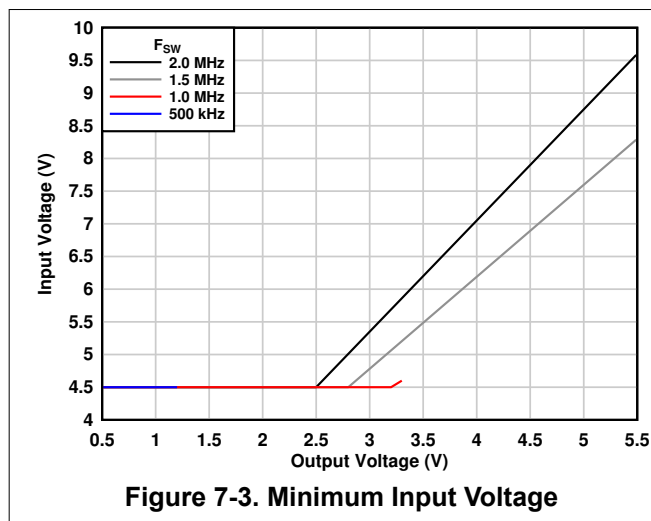

7.3.4 Recommended Settings

Table 7-2 lists the recommended operating settings for several common output voltages. The table takes into account the minimum and maximum input voltage limits along with timing and current limitations. The table also lists the minimum required effective output capacitance for each output voltage. Also included in this table is the minimum required input voltage and required enable divider resistors to ensure safe turn ON at the minimum input voltage.

Refer to Table 7-1 for the allowable switching frequency when output current is > 5.5 A. When operating at a switching frequency other than the recommended, consult Section 7.3.3 for the minimum and maximum allowable input voltage.

When setting the switching frequency, both channels of the device are set to the same frequency. When operating in dual output configuration, make sure that both channels can be operated at the desired switching frequency by referencing Section 7.3.2.2.

Table 7-2. Recommended Settings

OUTPUT VOLTAGE (V)	TOP FEEDBACK RESISTOR $R_{FBT}^{(1)}$ (k Ω)	F_{sw} (kHz)	MODE2 RESISTOR (k Ω)	MINIMUM $C_{OUT}^{(2)}$ (μ F)	MINIMUM INPUT VOLTAGE (V)	BOTTOM ENABLE RESISTOR $R_{ENB}^{(3)}$ (k Ω)
0.5	open	500	10.7	400	4.5	- ⁽⁴⁾
0.8	6.04	500	10.7	280	4.5	-
0.9	8.06	1000	17.4	265	4.5	-
1.0	10.0	1000	17.4	250	4.5	-
1.1	12.1	1000	17.4	235	4.5	-
1.2	14.0	1000	17.4	220	4.5	-
1.5	20.0	1000	17.4	180	4.5	-
1.8	26.1	1000	17.4	140	4.5	-
2.5	40.2	1500	28.7	100	4.5	-
3.0	49.9	1500	28.7	85	4.8	29.4
3.3	56.2	1500	28.7	75	5.3	26.1
4.0	69.8	1500	28.7	65	6.2	21.5
4.5	80.6	2000	53.6	60	7.9	16.2
5.0	90.9	2000	53.6	50	8.8	14.3
5.5	100	2000	53.6	45	9.6	13.0

- (1) $R_{FBB} = 10\text{ k}\Omega$
- (2) Minimum C_{OUT} listed is the effective value, taking into account the effects of DC bias and temperature variation.
- (3) $R_{ENT} = 100\text{ k}\Omega$
- (4) "-" not required

7.3.5 Device Mode Configuration

The TPSM5D1806 provides a wide range of configurations through pin strapping of two pins: MODE1 and MODE2. These pins are used to configure the device outputs, set the phase offset, and set the switching frequency. The operating mode of the device can be either two independent 6-A outputs or both outputs connected together in parallel for increased current up to 12 A. In either application, a 10-k Ω resistor is required from MODE1 to MODE2.

7.3.5.1 MODE1 (Operating Mode and Phase Position)

Place a 10-k Ω resistor from MODE1 to MODE2.

Place a resistor from MODE1 to AGND to set the device in the desired operating mode. The MODE1 resistor also selects the phase position for each channel. See [Table 7-3](#) for MODE1 resistor values and the corresponding settings.

Table 7-3. Operating Mode and Phase Position Settings

OPERATING MODE	CHANNEL 1 PHASE POSITION (°)	CHANNEL 2 PHASE POSITION (°)	MODE1 RESISTOR (k Ω)	COMMENTS
Dual outputs	0	180	15.4	Sets phase position for both channels to 0° and 180°.
	90 ⁽¹⁾	270 ⁽¹⁾	24.9	Sets phase position for both channels to 90° and 270° from SYNC signal.
Paralleled outputs (2 phase)	0	180	10.7	Sets phase positions for both channels of the device.

(1) Requires synchronization to an external clock signal.

7.3.5.2 MODE2 (Setting the Switching Frequency)

Place a resistor from MODE2 to AGND to set the switching frequency of the device. See [Table 7-4](#) for MODE2 resistor values and the corresponding settings. For dual output applications, check [Table 7-1](#) to make sure both outputs can operate at the selected switching frequency.

If synchronizing to an external clock, the TPSM5D1806 can only be synchronized to a frequency that is within $\pm 20\%$ of the switching frequency set by the MODE2 pin.

Table 7-4. Switching Frequency Settings

SWITCHING FREQUENCY (kHz)	MODE2 RESISTOR (k Ω)
500	10.7
1000	17.4
1500	28.7
2000	53.6

7.3.6 Input Capacitors

The TPSM5D1806 requires a minimum input capacitance of 88 μF ($4 \times 22 \mu\text{F}$ or $2 \times 47 \mu\text{F}$) of ceramic type. High-quality, ceramic-type X5R or X7R capacitors with sufficient voltage rating are required. Place input capacitors, as close as possible to both VIN sides of the device, between VIN and PGND as shown in Figure 7-5. Applications with transient load requirements can benefit from adding additional bulk capacitance to the input as well.

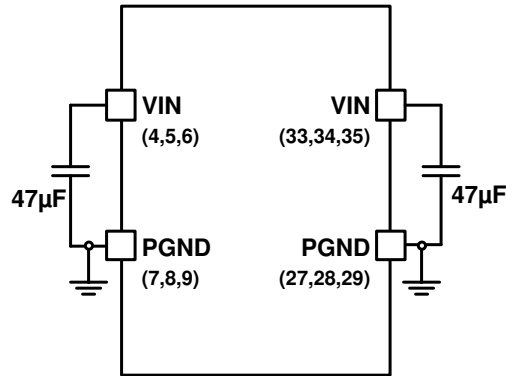

Figure 7-5. Input Capacitors Pin Connections

7.3.7 Minimum Required Output Capacitance

The TPSM5D1806 requires a minimum amount of ceramic output capacitance (per phase) depending on the output voltage setting. The amount of required output capacitance is shown in Figure 7-6 and is the amount of *effective* capacitance. The effects of DC bias and temperature variation must be considered when using ceramic capacitance. For ceramic capacitors, the package size, voltage rating, and dielectric material contributes to differences between the standard rated value and the actual effective value of the capacitance. When adding additional capacitance above the minimum, the capacitance can be ceramic type, low-ESR polymer type, or a combination of the two.

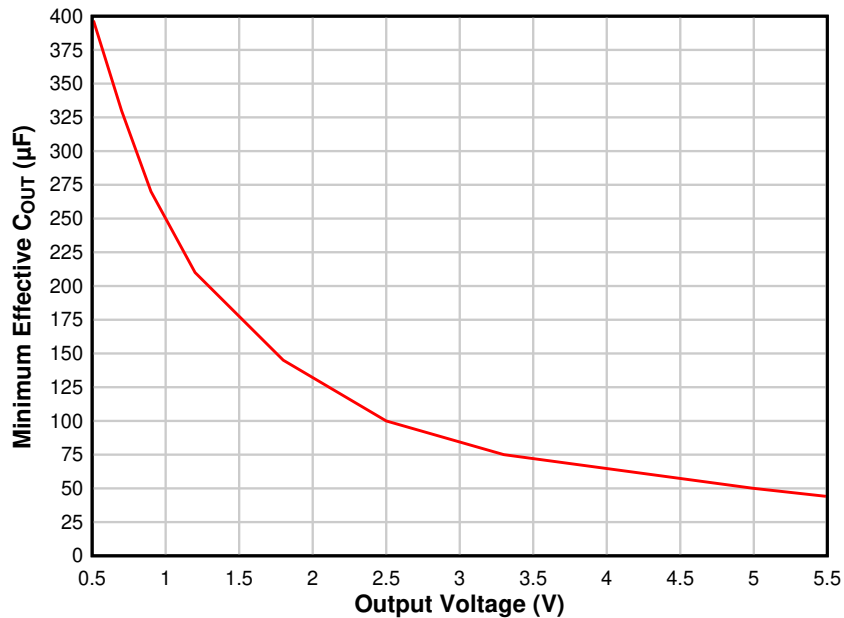

Figure 7-6. Minimum Required Output Capacitance (per Phase)

7.3.8 Enable and UVLO

The precision enable feature of the TPSM6D1806 allows the voltage on the EN pin (V_{EN}) to control the ON/OFF functionality of the device. The EN pin has an internal pullup. Floating the EN pin allows the device to start-up when a valid input voltage is applied. The TPSM5D1806 switching action and output regulation are enabled when V_{EN} is greater than 1.2 V (typical). While the device is switching, if the EN voltage falls below 1.1 V (typical), the device will stop switching.

It is recommended to control the turn ON and turn OFF using a resistor divider on the EN1 (EN2) pin, between V_{IN} and AGND (see Figure 7-7), set to a voltage greater than the minimum input voltage as shown in Figure 7-3. Select a top enable resistor of 100 k Ω and calculate the value for the bottom enable resistor (R_{ENB}) using Equation 2. It is recommended to use divider resistors with 1% tolerance or better, and with temperature coefficient of 100 ppm or lower.

$$R_{ENB} = 110 \div (V_{IN} - 1.1) \text{ (k}\Omega\text{)} \quad (2)$$

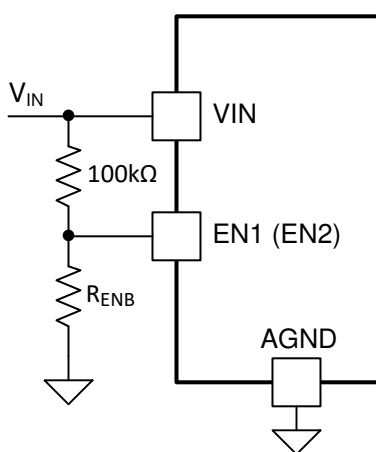

Figure 7-7. Enable ON/OFF Control

7.3.9 Soft Start

The TPSM5D1806 soft start feature limits the inrush current from the input supply when the device is powered up. For dual output configuration, the soft start time is internally programmed to 1 ms. The soft start pin should be left floating in dual output configuration.

The external soft start is enabled when the device is configured in parallel output operation. Parallel output applications that deliver high load current can have a large amount of capacitance at the output and can require longer soft start time. The soft start time for such applications can be extended by connecting an external capacitor C_{SS} from the soft-start pin to AGND. An internal current source ($I_{SS} = 2 \mu\text{A}$) charges C_{SS} and generates a ramp from 0 V to V_{FB} to control the ramp-up rate of the output voltage.

The soft-start capacitor is discharged when V_{OUT} is shut down by either hiccup protection or $\text{ENABLE} = \text{logic low}$. The total time required to discharge the soft-start capacitor completely is 500 μs .

7.3.10 Power Good

The Power Good pins (PGOOD1, PGOOD2) are open drain outputs which are connected to a pullup resistors of 10 k Ω to a source less than 5.5 V (for example, BP5) to indicate the output voltage is within the PGOOD range. The PGOOD detection is activated after soft start is completed. When the output voltage falls within a range of $\pm 10\%$ of the target, the PGOOD goes high after a 256- μs internal delay. During operation, if the output voltage falls outside of $\pm 10\%$ of target voltage, the PGOOD is pulled low after 10- μs delay. PGOOD feature is active while the voltage at VIN pin is either equal to or greater than 1.5 V.

7.3.11 Safe Start-up into Pre-Biased Outputs

The device has been designed to prevent the low-side MOSFET from discharging a pre-biased output.

7.3.12 BP5

The BP5 pin is the output of an internal 5-V regulator. Bypass this pin with a minimum of 1.5 μF of effective capacitance to AGND. Place the capacitor as close as possible to the BP5 pin. This pin can be used as a pullup voltage for Power Good signals.

7.3.13 Overcurrent Protection

For protection against load faults, the TPSM5D1806 implements a cycle-by-cycle peak current protection. When the inductor current hits the peak current limit threshold, the high-side FET turns off and the low-side FET turns on. The device monitors the valley current threshold during the high-side FET off-time. If the inductor current clears the valley current threshold, the high-side FET will turn on at the next clock edge. However, if the inductor current remains higher than valley current threshold, the next high-side FET cycle is skipped, the low-side FET remains on, and an internal counter is incremented. This counter increments every clock edge as long as the inductor current remains higher than valley current threshold. If the current falls below the valley current threshold at the next clock edge, the counter is reset. If the counter increments 16 consecutive clock cycles, a current limit fault is identified and the device enters hiccup mode to reduce power dissipation. In hiccup mode, the module continues in a cycle of successive shutdown and power up until the load fault is removed. During this period, the average current flowing into the fault is significantly reduced, which reduces power dissipation. Once the fault is removed, the module automatically recovers and returns to normal operation.

7.3.14 Thermal Shutdown

The internal thermal shutdown circuitry forces the device to stop switching if the junction temperature exceeds 165°C typically. The device reinitiates the power up sequence when the junction temperature drops below 145°C typically.

7.4 Device Functional Modes

7.4.1 Active Mode

The TPSM5D1806 is in active mode when VIN is above the turn-ON threshold and the EN pin voltage is above the EN high threshold. Floating the EN pin allows the device to start-up when a valid input voltage is applied. This allows self start-up of the TPSM5D1806 when the input voltage is in the operation range of 4.5 V to 16 V. Connecting a resistor divider between VIN, EN, and AGND adjusts the UVLO to delay the turn on until V_{IN} is closer to its regulated voltage.

7.4.2 Shutdown Mode

The EN pin provides electrical ON and OFF control for the TPSM5D1806. When the EN pin voltage is below the EN low threshold, the device is in shutdown mode. In shutdown mode, the standby current is 250 μA typical.

8 Application and Implementation

Note

Information in the following applications sections is not part of the TI component specification, and TI does not warrant its accuracy or completeness. TI's customers are responsible for determining suitability of components for their purposes. Customers should validate and test their design implementation to confirm system functionality.

8.1 Application Information

The TPSM5D1806 is a dual 6-A output, step-down, DC/DC power module. It is used to convert a higher DC voltage to two separate 6-A power rails or one combined 12-A power rail. The following design procedure can be used to select components for the TPSM5D1806. Alternately, the WEBENCH® software can be used to generate complete designs. When generating a design, the WEBENCH® software uses an iterative design procedure and accesses comprehensive databases of components. See www.ti.com for more details.

8.2 Typical Application (Dual Outputs)

Figure 8-1 shows a typical TPSM5D1806 schematic for a dual-output design.

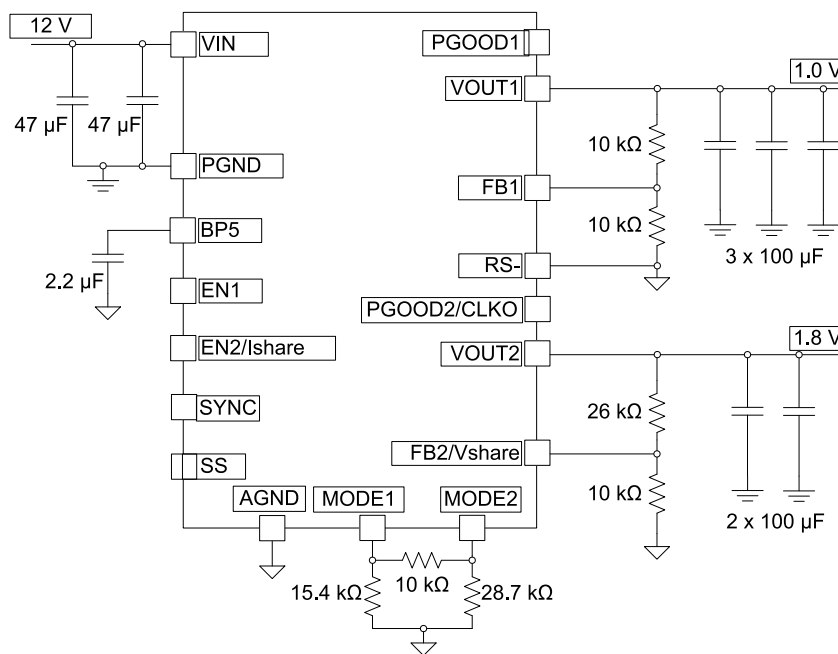

Figure 8-1. TPSM5D1806 Dual Output Typical Schematic

8.2.1 Design Requirements

For this design example, use the parameters listed in Table 8-1 as the input parameters and follow the design procedures in Section 8.2.2.

Table 8-1. Design Example Parameters

DESIGN PARAMETER	VALUE
Input voltage V_{IN}	12 V typical
Output voltage V_{OUT1}	1.0 V
Output voltage V_{OUT2}	1.8 V
Switching Frequency	1.5 MHz
Output current rating	6 A / Output

8.2.2 Detailed Design Procedure

8.2.2.1 Custom Design With WEBENCH® Tools

[Click here](#) to create a custom design using the TPSM5D1806 device with the WEBENCH® Power Designer.

1. Start by entering the input voltage (V_{IN}), output voltage (V_{OUT}), and output current (I_{OUT}) requirements.
2. Optimize the design for key parameters such as efficiency, footprint, and cost using the optimizer dial.
3. Compare the generated design with other possible solutions from Texas Instruments.

The WEBENCH Power Designer provides a customized schematic along with a list of materials with real-time pricing and component availability.

In most cases, these actions are available:

- Run electrical simulations to see important waveforms and circuit performance
- Run thermal simulations to understand board thermal performance
- Export customized schematic and layout into popular CAD formats
- Print PDF reports for the design, and share the design with colleagues

Get more information about WEBENCH tools at www.ti.com/WEBENCH.

8.2.2.2 Output Voltage Setpoint

The output voltage of the TPSM5D1806 device is externally adjustable using a resistor divider. The recommended value of R_{FBB} is 10 k Ω . The value for R_{FBT} can be calculated using [Equation 3](#):

$$R_{FBT} = 20 \times (V_{OUT} - 0.5) \text{ (k}\Omega\text{)} \quad (3)$$

For the desired output voltage of 1.0 V, the formula yields a value of 10 k Ω . Choose the closest available value of 10.0 k Ω for R_{FBT} .

For the desired output voltage of 1.8 V, the formula yields a value of 26 k Ω . Choose the closest available value of 26.1 k Ω for R_{FBT} .

8.2.2.3 Input Capacitors

The TPSM5D1806 requires a minimum input capacitance of 88 μ F of ceramic type. High-quality ceramic type X5R or X7R capacitors with sufficient voltage rating are recommended. An additional 100 μ F of non-ceramic capacitance is recommended for applications with transient load requirements. The voltage rating of the input capacitors must be greater than the maximum input voltage.

For this design example, two 47- μ F, 25-V, ceramic capacitors are used.

8.2.2.4 Output Capacitor Selection

The TPSM5D1806 requires a minimum amount of output capacitance for proper operation. The minimum amount of required output varies depending on the output voltage. See [Figure 7-6](#) for the required output capacitance.

For this design example, three 100- μ F, 6.3-V, ceramic capacitors are selected for the 1.0-V output. For the 1.8-V output, two 100- μ F, 6.3-V, ceramic capacitors are selected. Additional output capacitance can be needed to meet transient requirements.

8.2.3 Typical Application (Paralleled Outputs)

The dual outputs of the TPSM5D1806 can be combined to create a higher current (up to 12 A), single output. Figure 8-2 shows a typical TPSM5D1806 schematic for a paralleled output design.

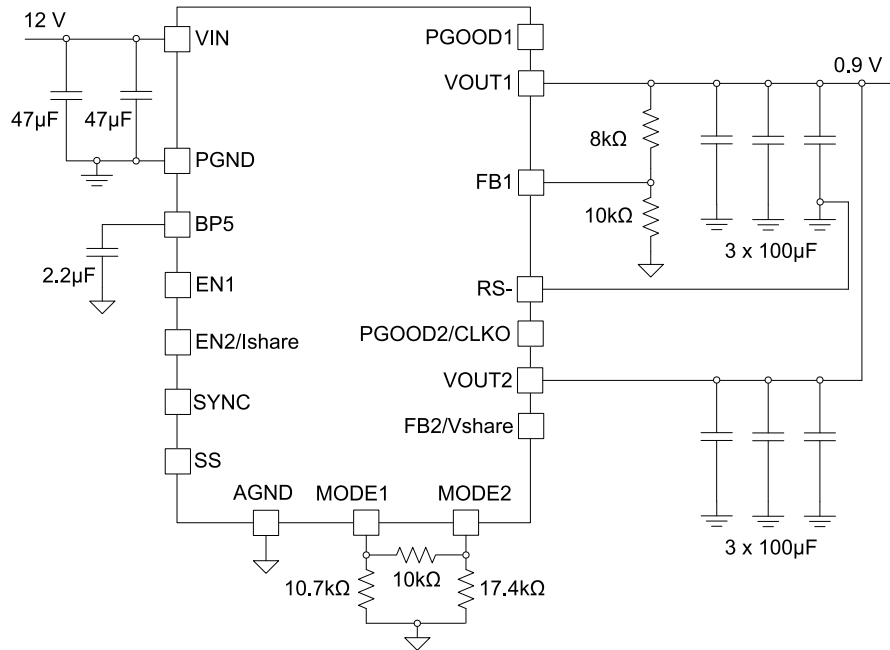

Figure 8-2. TPSM5D1806 Parallel Outputs Typical Schematic

8.2.3.1 Design Requirements

For this design example, use the parameters listed in Table 8-2 as the input parameters and follow the design procedures in Section 8.2.3.2.

Table 8-2. Design Example Parameters

DESIGN PARAMETER	VALUE
Input voltage V_{IN}	12 V typical
Output voltage	0.9 V
Switching Frequency	1.0 MHz
Output current rating	Up to 12 A

8.2.3.2 Detailed Design Procedure

8.2.3.2.1 Output Voltage Setpoint

The output voltage of the TPSM5D1806 device is externally adjustable using a resistor divider. The recommended value of R_{FBB} is 10 k Ω . The value for R_{FBT} can be calculated using [Equation 4](#):

$$R_{FBT} = 20 \times (V_{OUT} - 0.5) \text{ (k}\Omega\text{)} \quad (4)$$

For the desired output voltage of 0.9 V, the formula yields a value of 8 k Ω . Choose the closest available value of 8.06 k Ω for R_{FBT} or place two resistors in series to come closer to the exact value.

8.2.3.2.2 Input Capacitors

The TPSM5D1806 requires a minimum input capacitance of 88 μ F of ceramic type. High-quality ceramic type X5R or X7R capacitors with sufficient voltage rating are recommended. An additional 100 μ F of non-ceramic capacitance is recommended for applications with transient load requirements. The voltage rating of the input capacitors must be greater than the maximum input voltage.

For this design example, two 47- μ F, 25-V, ceramic capacitors are used.

8.2.3.2.3 Output Capacitor Selection

The TPSM5D1806 requires a minimum amount of output capacitance for proper operation. The minimum amount of required output varies depending on the output voltage. See [Figure 7-6](#) for the required output capacitance.

For this design example, six 100- μ F, 6.3-V, ceramic capacitors are selected for the 0.9-V output. Additional output capacitance can be needed to meet transient requirements.

9 Power Supply Recommendations

The TPSM5D1806 is designed to operate from an input voltage supply range between 4.5 V and 16 V. This input supply must be well-regulated and able to withstand maximum input current and maintain a stable voltage. The resistance of the input supply rail must be low enough that an input current transient does not cause a high enough drop at the TPSM5D1806 supply voltage that can cause a false UVLO fault triggering and system reset.

If the input supply is located more than a few centimeters from the TPSM5D1806, additional bulk capacitance can be required in addition to the ceramic bypass capacitors. The typical amount of bulk capacitance is a 47- μ F electrolytic type capacitor.

10 Layout

The performance of any switching power supply depends as much on the layout of the PCB as the component selection. The following guidelines help users design a PCB with the best power conversion performance, optimal thermal performance, and minimized generation of unwanted EMI.

10.1 Layout Guidelines

To achieve optimal electrical and thermal performance, an optimized PCB layout is required. [Figure 10-1](#) and [Figure 10-2](#) show typical PCB layouts. The following are some considerations for an optimized layout.

- Use large copper areas for power planes (VIN, VOUT, and PGND) to minimize conduction loss and thermal stress.
- Place ceramic input and output capacitors close to the device pins to minimize high frequency noise.
- Locate additional output capacitors between the ceramic capacitor and the load.
- Connect AGND to PGND at a single point.
- Place R_{FBT} and R_{FBB} as close as possible to the FB pin.
- Use multiple vias to connect the power planes to internal layers.

10.2 Layout Examples

Single Device Dual Output

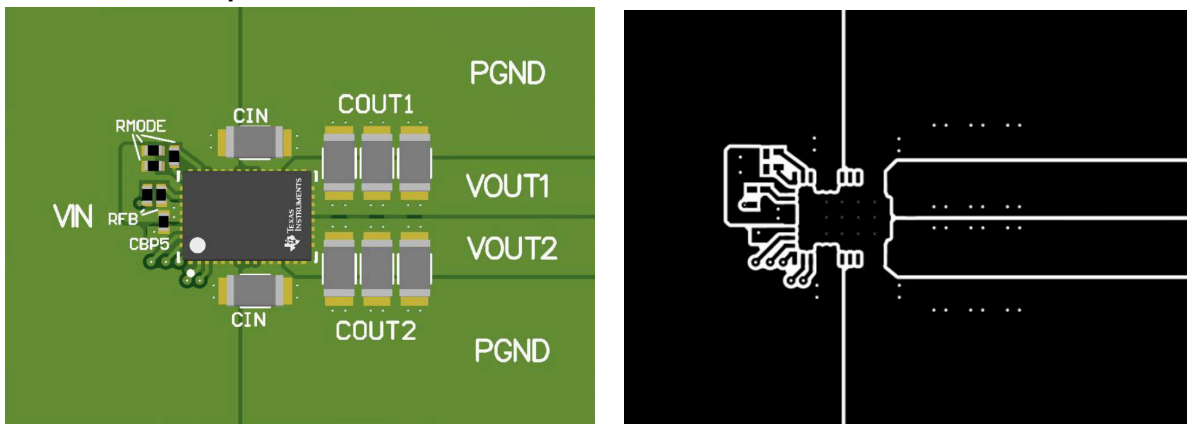

Figure 10-1. Typical Dual-Output Layout

Single Device Parallel Output

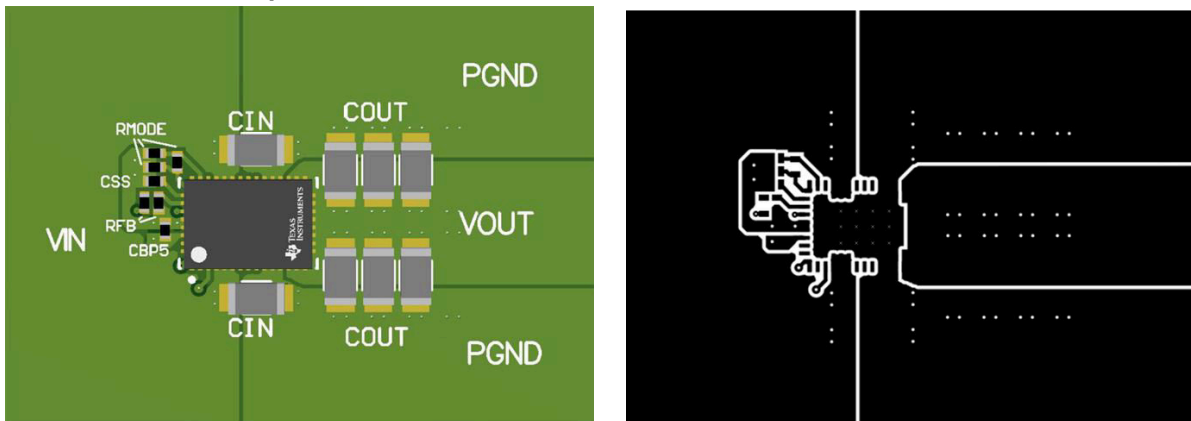

Figure 10-2. Typical Parallel-Output Layout

10.3 Package Specifications

TPSM5D1806		VALUE	UNIT
Weight		429	mg
Flammability	Meets UL 94 V-O		
MTBF Calculated Reliability	Per Bellcore TR-332, 50% stress, T _A = 40°C, ground benign	89.3	MHrs

10.4 EMI

The TPSM5D1806 is compliant with EN55011 Class-B radiated emissions. Figure 10-3 and Figure 10-4 show typical examples of radiated emissions plots for the TPSM5D1806. The graphs include the plots of the antenna in the horizontal and vertical positions.

EMI plots were measured using the standard TPSM5D1806EVM with ferrite beads (Murata, BLM18SG330SN1) in series with the input wires.

ADVANCE INFORMATION

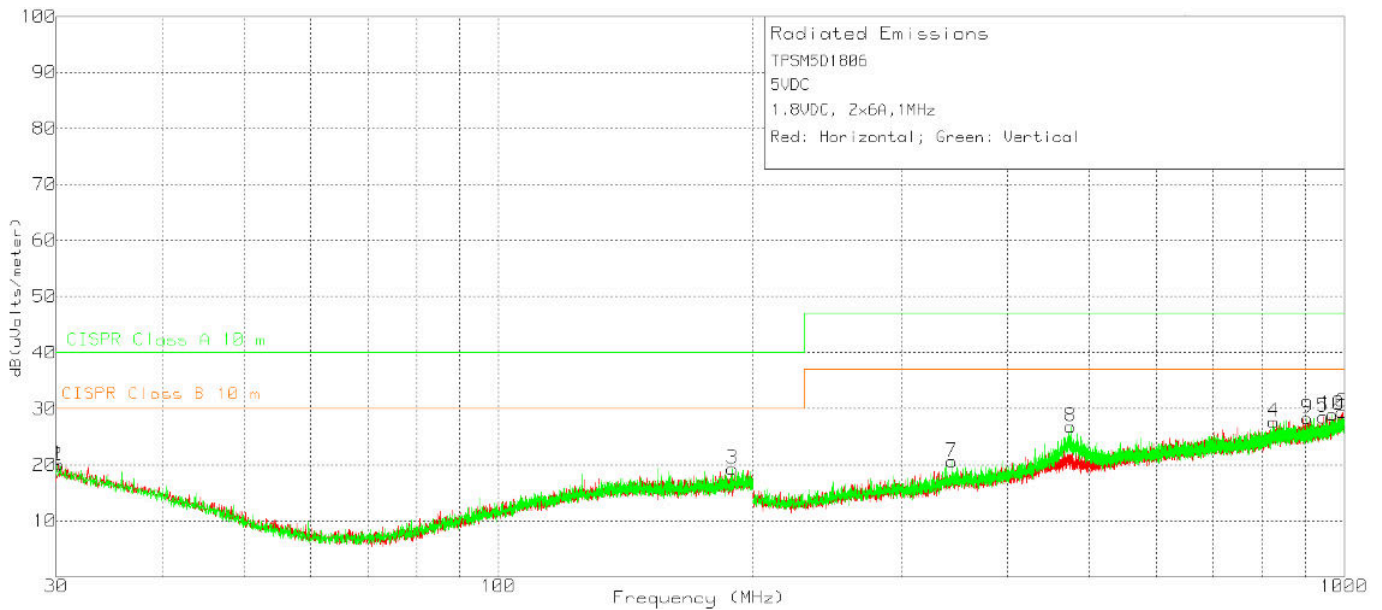

Figure 10-3. Radiated Emissions 5-V Input, 1.8-V Outputs, 6-A/Output Load

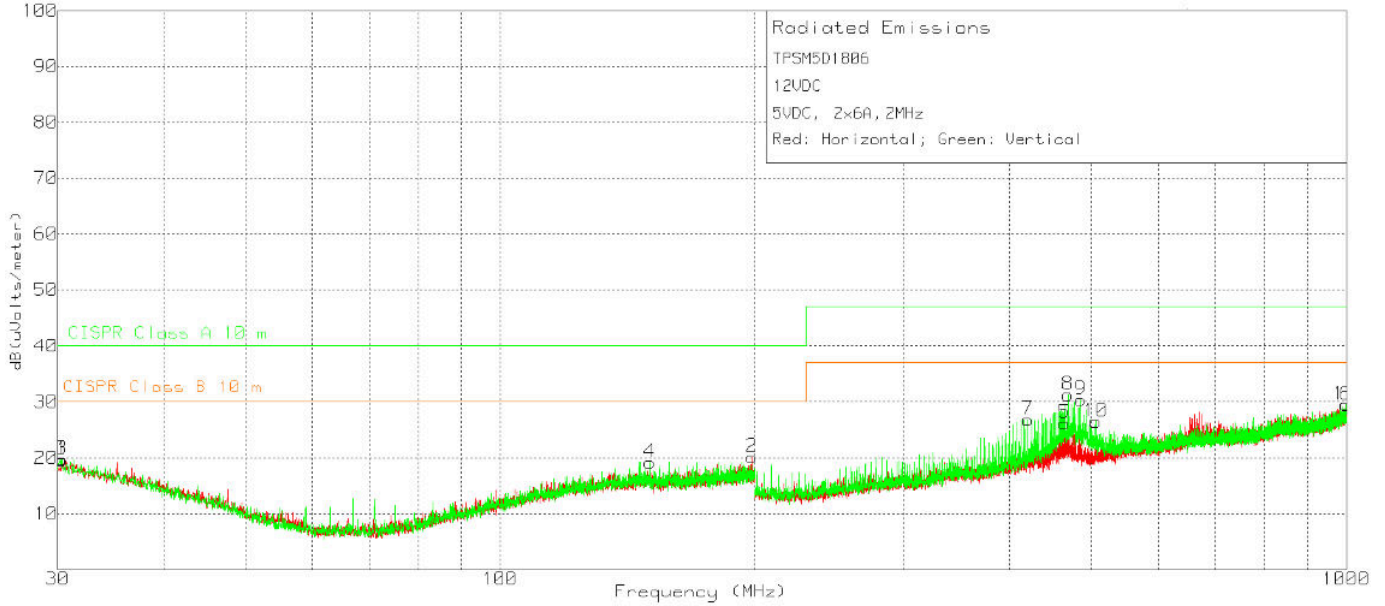

Figure 10-4. Radiated Emissions 12-V Input, 5-V Output, 6-A/Output Load

ADVANCE INFORMATION

11 Device and Documentation Support

11.1 Device Support

11.1.1 Development Support

11.1.1.1 Custom Design With WEBENCH® Tools

[Click here](#) to create a custom design using the TPSM5D1806 device with the WEBENCH® Power Designer.

1. Start by entering the input voltage (V_{IN}), output voltage (V_{OUT}), and output current (I_{OUT}) requirements.
2. Optimize the design for key parameters such as efficiency, footprint, and cost using the optimizer dial.
3. Compare the generated design with other possible solutions from Texas Instruments.

The WEBENCH Power Designer provides a customized schematic along with a list of materials with real-time pricing and component availability.

In most cases, these actions are available:

- Run electrical simulations to see important waveforms and circuit performance
- Run thermal simulations to understand board thermal performance
- Export customized schematic and layout into popular CAD formats
- Print PDF reports for the design, and share the design with colleagues

Get more information about WEBENCH tools at www.ti.com/WEBENCH.

11.2 Receiving Notification of Documentation Updates

To receive notification of documentation updates, navigate to the device product folder on ti.com. Click on *Subscribe to updates* to register and receive a weekly digest of any product information that has changed. For change details, review the revision history included in any revised document.

11.3 Support Resources

[TI E2E™ support forums](#) are an engineer's go-to source for fast, verified answers and design help — straight from the experts. Search existing answers or ask your own question to get the quick design help you need.

Linked content is provided "AS IS" by the respective contributors. They do not constitute TI specifications and do not necessarily reflect TI's views; see TI's [Terms of Use](#).

11.4 Trademarks

TI E2E™ is a trademark of Texas Instruments.

WEBENCH® is a registered trademark of Texas Instruments.

are registered trademarks of Texas Instruments.

All trademarks are the property of their respective owners.

11.5 Electrostatic Discharge Caution



This integrated circuit can be damaged by ESD. Texas Instruments recommends that all integrated circuits be handled with appropriate precautions. Failure to observe proper handling and installation procedures can cause damage.

ESD damage can range from subtle performance degradation to complete device failure. Precision integrated circuits may be more susceptible to damage because very small parametric changes could cause the device not to meet its published specifications.

11.6 Glossary

[TI Glossary](#) This glossary lists and explains terms, acronyms, and definitions.

12 Mechanical, Packaging, and Orderable Information

The following pages include mechanical packaging and orderable information. This information is the most current data available for the designated devices. This data is subject to change without notice and revision of this document. For browser-based versions of this data sheet, refer to the left-hand navigation.

PACKAGING INFORMATION

Orderable Device	Status (1)	Package Type	Package Drawing	Pins	Package Qty	Eco Plan (2)	Lead finish/ Ball material (6)	MSL Peak Temp (3)	Op Temp (°C)	Device Marking (4/5)	Samples
PTPSM5D1806RDBR	ACTIVE	B0QFN	RDB	51	2000	RoHS (In work & Non-Green)	Call TI	Call TI	-40 to 125		Samples
TPSM5D1806RDBR	PREVIEW	B0QFN	RDB	51	2000	RoHS (In Work) & Green	Call TI	Call TI	-40 to 125		

(1) The marketing status values are defined as follows:

ACTIVE: Product device recommended for new designs.

LIFEBUY: TI has announced that the device will be discontinued, and a lifetime-buy period is in effect.

NRND: Not recommended for new designs. Device is in production to support existing customers, but TI does not recommend using this part in a new design.

PREVIEW: Device has been announced but is not in production. Samples may or may not be available.

OBSOLETE: TI has discontinued the production of the device.

(2) **RoHS:** TI defines "RoHS" to mean semiconductor products that are compliant with the current EU RoHS requirements for all 10 RoHS substances, including the requirement that RoHS substance do not exceed 0.1% by weight in homogeneous materials. Where designed to be soldered at high temperatures, "RoHS" products are suitable for use in specified lead-free processes. TI may reference these types of products as "Pb-Free".

RoHS Exempt: TI defines "RoHS Exempt" to mean products that contain lead but are compliant with EU RoHS pursuant to a specific EU RoHS exemption.

Green: TI defines "Green" to mean the content of Chlorine (Cl) and Bromine (Br) based flame retardants meet JS709B low halogen requirements of <=1000ppm threshold. Antimony trioxide based flame retardants must also meet the <=1000ppm threshold requirement.

(3) MSL, Peak Temp. - The Moisture Sensitivity Level rating according to the JEDEC industry standard classifications, and peak solder temperature.

(4) There may be additional marking, which relates to the logo, the lot trace code information, or the environmental category on the device.

(5) Multiple Device Markings will be inside parentheses. Only one Device Marking contained in parentheses and separated by a "~" will appear on a device. If a line is indented then it is a continuation of the previous line and the two combined represent the entire Device Marking for that device.

(6) Lead finish/Ball material - Orderable Devices may have multiple material finish options. Finish options are separated by a vertical ruled line. Lead finish/Ball material values may wrap to two lines if the finish value exceeds the maximum column width.

Important Information and Disclaimer:The information provided on this page represents TI's knowledge and belief as of the date that it is provided. TI bases its knowledge and belief on information provided by third parties, and makes no representation or warranty as to the accuracy of such information. Efforts are underway to better integrate information from third parties. TI has taken and continues to take reasonable steps to provide representative and accurate information but may not have conducted destructive testing or chemical analysis on incoming materials and chemicals. TI and TI suppliers consider certain information to be proprietary, and thus CAS numbers and other limited information may not be available for release.

In no event shall TI's liability arising out of such information exceed the total purchase price of the TI part(s) at issue in this document sold by TI to Customer on an annual basis.

IMPORTANT NOTICE AND DISCLAIMER

TI PROVIDES TECHNICAL AND RELIABILITY DATA (INCLUDING DATASHEETS), DESIGN RESOURCES (INCLUDING REFERENCE DESIGNS), APPLICATION OR OTHER DESIGN ADVICE, WEB TOOLS, SAFETY INFORMATION, AND OTHER RESOURCES "AS IS" AND WITH ALL FAULTS, AND DISCLAIMS ALL WARRANTIES, EXPRESS AND IMPLIED, INCLUDING WITHOUT LIMITATION ANY IMPLIED WARRANTIES OF MERCHANTABILITY, FITNESS FOR A PARTICULAR PURPOSE OR NON-INFRINGEMENT OF THIRD PARTY INTELLECTUAL PROPERTY RIGHTS.

These resources are intended for skilled developers designing with TI products. You are solely responsible for (1) selecting the appropriate TI products for your application, (2) designing, validating and testing your application, and (3) ensuring your application meets applicable standards, and any other safety, security, or other requirements. These resources are subject to change without notice. TI grants you permission to use these resources only for development of an application that uses the TI products described in the resource. Other reproduction and display of these resources is prohibited. No license is granted to any other TI intellectual property right or to any third party intellectual property right. TI disclaims responsibility for, and you will fully indemnify TI and its representatives against, any claims, damages, costs, losses, and liabilities arising out of your use of these resources.

TI's products are provided subject to TI's Terms of Sale (www.ti.com/legal/termsofsale.html) or other applicable terms available either on ti.com or provided in conjunction with such TI products. TI's provision of these resources does not expand or otherwise alter TI's applicable warranties or warranty disclaimers for TI products.

Mailing Address: Texas Instruments, Post Office Box 655303, Dallas, Texas 75265
Copyright © 2020, Texas Instruments Incorporated