

## LCD Bias Power Integrated with WLED Backlight Drivers

Check for Samples: [TPS65142](#)

### FEATURES

- **Integrated Bias and Backlight Power**
- **2.3 V to 6 V Input Voltage Range for Bias**
  - Up to 16.5 V Boost Converter with 1.8 A Switch Current
  - 1.2 MHz/650 kHz Selectable Switching Frequency
  - Internal Compensation
  - Internal Soft-start at Power on
  - Reset Function ( $\overline{\text{XAO}}$  Signal)
  - Regulated VGH
  - Regulated VGL
  - Gate Voltage Shaping
  - LCD Discharge Function
- **150 mA Unity Gain VCOM Buffer**
- **4.5 V to 24 V WLED Backlight Input Range**
  - Integrated 1.5 A/40 V MOSFET
  - Boost Output Tracks WLED Voltage
  - Internal Compensation
  - External Current Setting Input
  - 6 Current-Sink Channels of 25 mA
  - Better than 3% Current Matching
  - Up to 1000:1 PWM Dimming Range

- **Overvoltage Protection**
- **Thermal Shutdown**
- **Undervoltage Lockout**
- **32-Pin 6 x 3 mm<sup>2</sup> QFN Package**

### APPLICATIONS

- **Note-PC TFT-LCD Panels**
- **Tablet TFT-LCD Panels**

### DESCRIPTION

The TPS65142 provides a compact solution to the bias power and the WLED backlight in note-pc TFT-LCD panels. The device features a boost converter, a positive charge pump regulator, and a negative charge pump regulator to power the source drivers and the gate drivers. A 150mA unity-gain high-speed buffer is offered to drive the VCOM plane. Gate voltage shaping and the LCD discharge function are offered to improve the image quality. A reset function allows a proper reset of the TCON at the power on. The TPS65142 also offers the complete solution to driver up to 6 chains of WLEDs with 1000:1 ratio PWM dimming.

All features are integrated in a compact 6 x 3 mm<sup>2</sup> Thin QFN package.

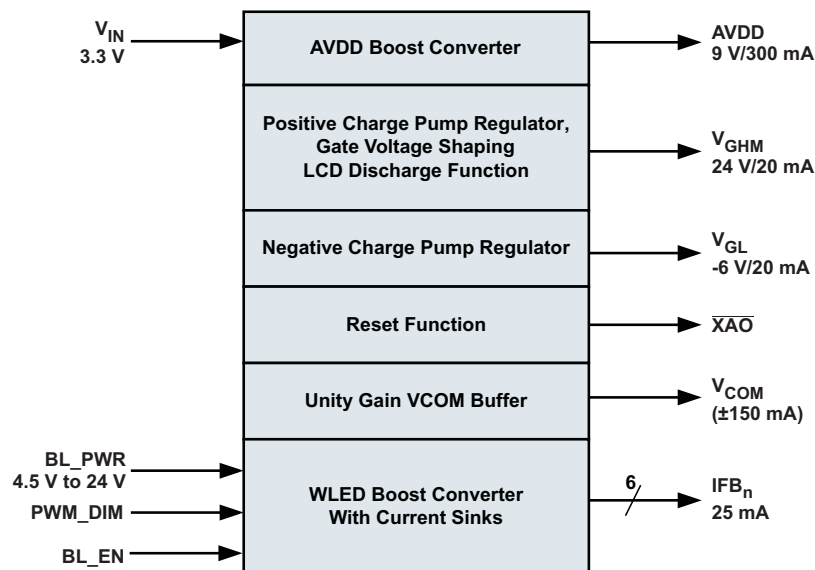

Please be aware that an important notice concerning availability, standard warranty, and use in critical applications of Texas Instruments semiconductor products and disclaimers thereto appears at the end of this data sheet.

# TPS65142

SLVSAX5 – JULY 2011

www.ti.com



These devices have limited built-in ESD protection. The leads should be shorted together or the device placed in conductive foam during storage or handling to prevent electrostatic damage to the MOS gates.

## ORDERING INFORMATION<sup>(1)(2)</sup>

T <sub>A</sub>	ORDERING	PACKAGE	PACKAGE MARKING
-40°C to 85°C	TPS65142RTGR	32-Pin 6×3 TQFN	TS65142

- (1) The device is supplied taped and reeled, with 3000 devices per reel.  
 (2) All voltage values are with respect to ground terminal.

## ABSOLUTE MAXIMUM RATINGS<sup>(1)</sup>

over operating free-air temperature range (unless otherwise noted)

		VALUE		UNIT
		MIN	MAX	
Voltage	Input voltage range	-0.3	6.5	V
	FB, FREQ, COMP, VDPM, VFLK, VDET, FBN, $\overline{XAO}$	-0.3	6.5	V
	SW, OPI, OPO, SUP, DRVP, DRVN, EN, DCTRL, IFB1 to IFB6	-0.3	20	V
	REF, FBP and ISET	-0.3	3.6	V
	VGH, VGHM, RE	-0.3	35	V
	VBAT	-0.3	24	V
	BL_SW and VO	-0.3	40	V
ESD rating	Human Body Model		2	kV
	Machine Model		200	V
	Charged Device Model		500	V
Continuous power dissipation		See the Thermal Information Table		
Storage temperature range		-65	150	°C

- (1) Stresses beyond those listed under “absolute maximum ratings” may cause permanent damage to the device. These are stress ratings only, and functional operation of the device at these or any other conditions beyond those indicated under “recommended operating conditions” is not implied. Exposure to absolute-maximum-rated conditions for extended periods may affect device reliability.

## THERMAL INFORMATION

THERMAL METRIC <sup>(1)</sup>		TPS65142	UNITS
		QFN (32 PINS)	
$\theta_{JA}$	Junction-to-ambient thermal resistance	35.4	°C/W
$\theta_{JcTop}$	Junction-to-case (top) thermal resistance	19.9	
$\theta_{JB}$	Junction-to-board thermal resistance	5.6	
$\psi_{JT}$	Junction-to-top characterization parameter	0.2	
$\psi_{JB}$	Junction-to-board characterization parameter	5.4	
$\theta_{JcBot}$	Junction-to-case (bottom) thermal resistance	1.7	

- (1) For more information about traditional and new thermal metrics, see the *IC Package Thermal Metrics* application report, [SPRA953](#).

**RECOMMENDED OPERATING CONDITIONS**

		MIN	TYP	MAX	UNIT
$V_{IN}$	Input voltage range	2.3		6	V
$V_S$	AVDD Boost output voltage range <sup>(1)</sup>			16.5	V
$V_{GH}$	Positive charge pump output voltage range			32	V
$V_{BAT}$	Battery voltage range	4.5		24	V
$V_O$	WLED boost converter output voltage			38	V
$V_{GL}$	Negative charge pump output voltage range	-14			V
$L_1$	Inductor for the AVDD boost converter <sup>(2)</sup>	4.7		10	$\mu$ H
$L_2$	Inductor for the WLED boost converter	4.7		10	$\mu$ H
$C_{IN}$	Input decoupling capacitor	1			$\mu$ F
$C_{O1}$	Output decoupling capacitor of the AVDD boost converter		20		$\mu$ F
$C_{O2}$	Output decoupling capacitor of the WLED boost converter	2.2		10	$\mu$ F
$T_A$	Operating ambient temperature	-40		85	$^{\circ}$ C
$T_J$	Operating junction temperature	-40		125	$^{\circ}$ C

(1) Maximum output voltage is limited by the overvoltage protection and not the maximum power switch rating

(2) Refer to application section for further information.

**ELECTRICAL CHARACTERISTICS**

$V_{IN} = 3.3$  V,  $V_S = 9$  V,  $V_{GH} = 20$  V,  $V_{BAT} = 10.8$  V,  $I_{SET} = 15$   $\mu$ A,  $V_{IFBx} = 0.5$  V,  $EN = V_{IN}$ ,  $T_A = -40^{\circ}$ C to  $85^{\circ}$ C, typical values are at  $T_A = 25^{\circ}$ C (unless otherwise noted)

PARAMETER		TEST CONDITIONS	MIN	TYP	MAX	UNIT
<b>SUPPLY</b>						
$I_{Q(IN)}$	Operating quiescent current into VIN	Device not switching		0.17	0.5	mA
$I_{Q(VGH)}$	Operating quiescent current into VGH	$V_{GH} = 20$ V, VFLK not oscillating		22	40	$\mu$ A
$I_{Q(SUP)}$	Operating quiescent current into SUP	Device not switching. $V_S = 9$ V, EN = high		2.8		mA
		Device not switching. $V_S = 9$ V, EN = GND		2.5		
$I_{SD(VIN)}$	Shutdown current into VIN	$V_{IN} = 1.8$ V, $V_S =$ GND		20	33	$\mu$ A
$I_{SD(VGH)}$	Shutdown current into VGH	$V_{IN} = 1.8$ V, $V_{GH} = 32$ V		30	50	$\mu$ A
$I_{SD(SUP)}$	Shutdown current into SUP	$V_{IN} = 1.8$ V, $V_S = 16.5$ V		3	5	$\mu$ A
$I_{Q(BAT)}$	VBAT pin quiescent current	WLED boost regulator switching, no load			0.2	mA
$I_{SD(BAT)}$	VBAT pin shutdown current	EN = GND			18	$\mu$ A
$I_{Q(VO)}$	VO pin quiescent current	$V_O = 35$ V			75	$\mu$ A
UVLO	VIN under voltage lockout threshold	$V_{IN}$ falling	1.9		2.1	V
		$V_{IN}$ rising			2.2	
	VBAT under voltage lockout threshold	$V_{BAT}$ rising			4.45	V
		$V_{BAT}$ falling	3.9			
	UVLO voltage of WLED control circuit			2.2	2.5	V

**ELECTRICAL CHARACTERISTICS (continued)**

$V_{IN} = 3.3\text{ V}$ ,  $V_S = 9\text{ V}$ ,  $V_{GH} = 20\text{ V}$ ,  $V_{BAT} = 10.8\text{ V}$ ,  $I_{SET} = 15\mu\text{A}$ ,  $V_{IFBx} = 0.5\text{ V}$ ,  $EN = V_{IN}$ ,  $T_A = -40^\circ\text{C}$  to  $85^\circ\text{C}$ , typical values are at  $T_A = 25^\circ\text{C}$  (unless otherwise noted)

PARAMETER		TEST CONDITIONS	MIN	TYP	MAX	UNIT
<b>LOGIC SIGNALS FREQ, VFLK, EN, DCTRL</b>						
$V_{IH}$	Logic high input voltage	$V_{IN} = 2.5\text{ V to }6\text{ V}$	2.0			V
$V_{IL}$	Logic low input voltage	$V_{IN} = 2.5\text{ V to }6\text{ V}$			0.5	V
$I_{LKG}$	Input leakage current of VFLK pin	VFLK = 6 V, FREQ = GND			0.1	$\mu\text{A}$
$R_{PD}$	Pull-down resistance for EN and DCTRL pins	EN = DCTRL = 3.3 V	400	800	1600	k $\Omega$
<b>AVDD BOOST CONVERTER</b>						
$V_S$	Output voltage boost <sup>(1)</sup>		7		16.5	V
$V_{OVP}$	Overvoltage protection	VS rising	16.9	18	19	V
$V_{FB}$	Feedback regulation voltage	$T_A = -40^\circ\text{C}$ to $85^\circ\text{C}$	1.226	1.240	1.254	V
		$T_A = 25^\circ\text{C}$	1.230	1.240	1.250	
$I_{FB}$	Feedback input bias current	$V_{FB} = 1.240\text{ V}$			0.1	$\mu\text{A}$
$r_{DS(ON)}$	N-channel MOSFET on-resistance	$V_{IN} = V_{GS} = 5\text{ V}$ , $I_{SW} = \text{current limit}$		0.13	0.38	$\Omega$
		$V_{IN} = V_{GS} = 3.3\text{ V}$ , $I_{SW} = \text{current limit}$		0.15	0.44	
$I_{Lkg(SW)}$	AVDD Boost converter SW leakage current	$V_{IN} = 1.8\text{ V}$ , $V_{SW} = 17\text{ V}$ , Device not switching			30	$\mu\text{A}$
$I_{LIM}$	N-Channel MOSFET current limit	$V_{IN} = 2.5\text{ V to }6\text{ V}$	1.8	2.5	3.2	A
		$V_{IN} = 2.3\text{ V to }2.5\text{ V}$	1.5			A
$f_{BOOST}$	Switching frequency	FREQ = high	0.9	1.2	1.5	MHz
		FREQ = low	470	625	780	kHz
$T_{SS}$	Softstart time	FREQ = high, $L_1 = 6.8\mu\text{H}$ , $C_{O1} = 2.0\mu\text{F}$ and 10 mA load current		2		ms
		Line regulation	$V_{IN} = 2.5\text{ V ... }6\text{ V}$ , $I_{OUT} = 10\text{ mA}$		0.008	%/V
		Load regulation	$I_{OUT} = 0\text{ A ... }500\text{ mA}$		0.15	%/A
<b>VGH REGULATOR</b>						
$f_{SWP}$	Switching frequency		0.5 x $f_{BOOST}$			MHz
$V_{FBP}$	Reference voltage of feedback	$T_A = -40^\circ\text{C}$ to $85^\circ\text{C}$	1.210	1.240	1.270	V
		$T_A = 25^\circ\text{C}$	1.221	1.240	1.259	
$I_{FBP}$	Feedback input bias current	$V_{FBP} = 1.240\text{ V}$			0.1	$\mu\text{A}$
$r_{DS(ON)P1}$	DRVP $R_{DS(ON)}$ (PMOS)	$V_S = 9\text{ V}$ , $I_{(DRVP)} = 40\text{ mA}$		8	20	$\Omega$
$r_{DS(ON)N1}$	DRVP $R_{DS(ON)}$ (NMOS)	$V_S = 9\text{ V}$ , $I_{(DRVP)} = -40\text{ mA}$		3	10	$\Omega$
<b>VGL REGULATOR</b>						
$f_{SWN}$	Switching frequency		0.5 x $f_{BOOST}$			MHz
$V_{REF}$	Reference voltage		3.05	3.12	3.18	V
$V_{FBN}$	Reference voltage of feedback		-48	0	48	mV
$I_{FBN}$	Feedback input bias current	$V_{FBN} = 0\text{ V}$			0.1	$\mu\text{A}$
$r_{DS(ON)P2}$	DRVN $R_{DS(ON)}$ (PMOS)	$V_S = 9\text{ V}$ , $I_{(DRVN)} = 40\text{ mA}$		8	20	$\Omega$
$r_{DS(ON)N2}$	DRVN $R_{DS(ON)}$ (NMOS)	$V_S = 9\text{ V}$ , $I_{(DRVN)} = -40\text{ mA}$		3	10	$\Omega$
<b>GATE VOLTAGE SHAPING VGHM</b>						
$I_{(DPM)}$	Capacitor charge current VDPM pin		17	20	23	$\mu\text{A}$
$r_{DS(ON)M1}$	VGH to VGHM $r_{DS(ON)}$ (M1 PMOS)	VFLK = low, $I_{(VGHM)} = 20\text{ mA}$		13	25	$\Omega$
$r_{DS(ON)M2}$	VGHM to RE $r_{DS(ON)}$ (M2 PMOS)	VFLK = high, $I_{(VGHM)} = 20\text{ mA}$ , VGHM = 7.5 V		13	25	$\Omega$

(1) Maximum output voltage limited by the overvoltage protection and not the maximum power switch rating

**ELECTRICAL CHARACTERISTICS (continued)**
 $V_{IN} = 3.3\text{ V}$ ,  $V_S = 9\text{ V}$ ,  $V_{GH} = 20\text{ V}$ ,  $V_{BAT} = 10.8\text{ V}$ ,  $I_{ISET} = 15\mu\text{A}$ ,  $V_{IFBx} = 0.5\text{ V}$ ,  $EN = V_{IN}$ ,  $T_A = -40^\circ\text{C}$  to  $85^\circ\text{C}$ , typical values are at  $T_A = 25^\circ\text{C}$  (unless otherwise noted)

PARAMETER		TEST CONDITIONS	MIN	TYP	MAX	UNIT
<b>RESET</b>						
$V_{IN(DET)}$	VIN voltage range for reset detection		1.6		6	V
$V_{(DET)}$	Reset IC threshold	Falling	1.074	1.1	1.126	V
$V_{(DET\_HYS)}$	Reset IC threshold hysteresis			65		mV
$I_{(DET\_B)}$	Reset IC input bias current	$V_{(DET)} = 1.1\text{ V}$			0.1	$\mu\text{A}$
$I_{XAO}$	Reset sink current capability <sup>(2)</sup>	$V_{(XAO\_ON)} = 0.5\text{ V}$	1			mA
$I_{LKG(XAO)}$	Reset leakage current	$V_{(XAO)} = V_{IN} = 3.3\text{ V}$			2	$\mu\text{A}$
<b>VCOM BUFFER</b>						
$V_{SUP}$	SUP input supply range <sup>(3)</sup>		7		16.5	V
$I_B$	Input bias current	$V_{CM} = V_{(OPI)} = V_{SUP}/2 = 4.5\text{ V}$	-1		1	$\mu\text{A}$
$V_{CM}$	Common Mode Input Voltage Range	$V_{OFFSET} = 10\text{ mV}$ , $I_{(OPO)} = 10\text{ mA}$	2		$V_S - 2$	V
CMRR	Common Mode Rejection Ratio <sup>(4)</sup>	$V_{CM} = V_{(OPI)} = V_{(SUP)}/2 = 4.5\text{ V}$ , 1 MHz		66		dB
$A_{VOL}$	Open Loop Gain <sup>(4)</sup>	$V_{CM} = V_{(OPI)} = V_{(SUP)}/2 = 4.5\text{ V}$ , no load		90		dB
$V_{OL}$	Output Voltage Swing Low	$I_{(OPO)} = 10\text{ mA}$		0.10	0.25	V
$V_{OH}$	Output Voltage Swing High	$I_{(OPO)} = 10\text{ mA}$	$V_S - 0.8$	$V_S - 0.65$		V
$I_{SC}$	Short Circuit Current	Source ( $V_{(OPI)} = 4.5\text{ V}$ , $V_{(OPO)} = \text{GND}$ )	150			mA
		Sink ( $V_{(OPI)} = 4.5\text{ V}$ , $V_{(OPO)} = 9\text{ V}$ )	150			
$I_O$	Output Current	Source ( $V_{(OPI)} = 4.5\text{ V}$ , $V_{(OFFSET)} = 15\text{ mV}$ )		150		mA
		Sink ( $V_{(OPI)} = 4.5\text{ V}$ , $V_{(OFFSET)} = 15\text{ mV}$ )		140		
PSRR	Power Supply Rejection Ratio <sup>(4)</sup>			40		dB
SR	Slew Rate <sup>(4)</sup>	$A_V = 1$ , $V_{(OPI)} = 2\text{ V}_{PP}$		40		V/ $\mu\text{s}$
BW	-3 db Bandwidth <sup>(4)</sup>	$A_V = 1$ , $V_{(OPI)} = 60\text{ mV}_{PP}$		50		MHz

(2) External pull-up resistor to be chosen so that the current flowing into  $\overline{XAO}$  Pin ( $I_{XAO} = 0\text{ V}$ ) when active is below  $I_{(XAO)\text{ MIN}} = 1\text{ mA}$ .

(3) Maximum output voltage limited by the Overvoltage Protection and not the maximum Power Switch rating.

(4) Typical values are for reference only

# TPS65142

SLVSAX5 – JULY 2011

[www.ti.com](http://www.ti.com)

## ELECTRICAL CHARACTERISTICS (continued)

$V_{IN} = 3.3\text{ V}$ ,  $V_S = 9\text{ V}$ ,  $V_{GH} = 20\text{ V}$ ,  $V_{BAT} = 10.8\text{ V}$ ,  $I_{ISET} = 15\mu\text{A}$ ,  $V_{IFBx} = 0.5\text{ V}$ ,  $EN = V_{IN}$ ,  $T_A = -40^\circ\text{C}$  to  $85^\circ\text{C}$ , typical values are at  $T_A = 25^\circ\text{C}$  (unless otherwise noted)

PARAMETER		TEST CONDITIONS	MIN	TYP	MAX	UNIT
<b>WLED CURRENT REGULATION</b>						
$V_{(ISET)}$	ISET pin voltage		1.204	1.229	1.253	V
$K_{(ISET)}$	Current multiple $I_{OUT}/ISET$ <sup>(5)</sup>	ISET current = 20 $\mu\text{A}$		1000		
$I_{FB}$	Current accuracy <sup>(5)</sup>	ISET current = 20 $\mu\text{A}$	19.4	20	20.6	mA
$K_m$	$(I_{max}-I_{min})/I_{AVG}$	ISET current = 20 $\mu\text{A}$		1%	2.5%	
$I_{LKG}$	IFB pin leakage current	IFB voltage = 20 V on all pins			3	$\mu\text{A}$
$I_{(IFB\_MAX)}$	Current sink max output current	IFB = 450 mV	25			mA
<b>WLED BOOST OUTPUT REGULATION</b>						
$V_{(IFB\_L)}$	$V_O$ dial up threshold	Measured on $V_{(IFB)}_{min}$		400		mV
$V_{(IFB\_H)}$	$V_O$ dial down threshold	Measured on $V_{(IFB)}_{min}$		700		mV
$V_{(reg\_L)}$	Minimum $V_O$ regulation voltage				16	V
$V_{O(step)}$	$V_O$ stepping voltage			100	150	mV
<b>WLED BOOST REGULATOR POWER SWITCH</b>						
$R_{(PWM\_SW)}$	PWM FET on-resistance			0.2	0.45	$\Omega$
$I_{(LN\_NFET)}$	PWM FET leakage current	$V_{(BL\_SW)} = 35\text{ V}$ , $T_A = 25^\circ\text{C}$			1	$\mu\text{A}$
<b>WLED OSCILLATOR</b>						
$f_S$	Oscillator frequency		0.9	1.0	1.2	MHz
$D_{max}$	Maximum duty cycle of WLED Boost	IFB = 0 V	85%	94%		
$D_{min}$	Minimum duty cycle of WLED Boost				7%	
<b>CURRENT LIMIT, OVER VOLTAGE AND SHORT CIRCUIT PROTECTIONS</b>						
$I_{LIM}$	N-Channel MOSFET current limit	$D = D_{MAX}$	1.5		3	A
$V_{OVP}$	VO overvoltage threshold	Measured on the VO pin	38	39	40	V
$V_{OVP(IFB)}$	IFB overvoltage threshold	Measured on the IFBx pin	15	17	20	V
$V_{SC}$	Short circuit detection threshold	$V_{BAT} - V_O$ , $V_O$ ramp down		1.7	2.5	V
$V_{SC(dly)}$	Short circuit detection delay during start up			32		ms
<b>THERMAL SHUTDOWN</b>						
$T_{SD}$	Thermal shutdown	Temperature rising		150		$^\circ\text{C}$
$T_{SDHYS}$	Thermal shutdown hysteresis			14		$^\circ\text{C}$

(5) Tested at  $T_A = 25^\circ\text{C}$  to  $85^\circ$ .

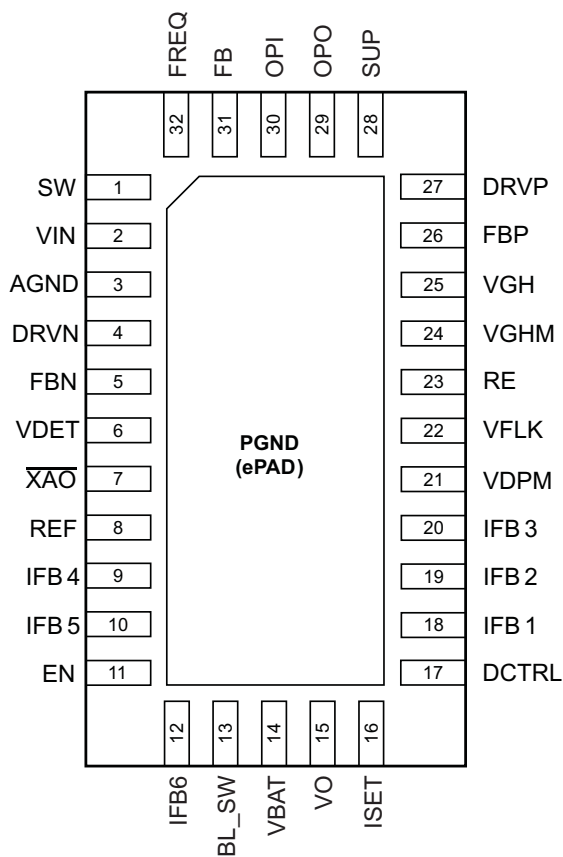
**DEVICE INFORMATION**
**PIN ASSIGNMENT  
TOP VIEW (6×3 32-PIN QFN PACKAGE)**

**PIN FUNCTIONS**

PIN		I/O	DESCRIPTION
NAME	NO.		
SW	1		Switch pin of the AVDD boost converter
VIN	2	I	Input supply pin
AGND	3		Analog ground
DRVN	4	O	Voltage driver of the negative charge pump
FBN	5	I	Negative charge pump feedback pin
VDET	6	I	Reset IC threshold pin (Voltage divider)
XAO	7	O	Reset IC output pulling down XAO pin when active.
REF	8	O	Reference voltage for the negative charge pump
IFB4	9	I	Channel 4 of the WLED backlight current sink
IFB5	10	I	Channel 5 of the WLED backlight current sink
EN	11	I	Backlight enable input
IFB6	12	I	Channel 6 of the WLED backlight current sink
BL_SW	13		The backlight boost converter switching node
VBAT	14	I	Input of the backlight boost converter
VO	15	O	The output of the backlight boost converter
ISET	16	I	WLED current sink level programming input
DCTRL	17	I	Backlight PWM dimming control input
IFB1	18	I	Channel 1 of the WLED backlight current sink

**PIN FUNCTIONS (continued)**

PIN		I/O	DESCRIPTION
NAME	NO.		
IFB2	19	I	Channel 2 of the WLED backlight current sink
IFB3	20	I	Channel 3 of the WLED backlight current sink
VDPM	21	O	Sets the delay to enable VGHM Output. Pin for external capacitor. Floating if no delay needed
VFLK	22	I	Charge/discharge signal for VGHM
RE	23		Sets the slope for the gate shaping function. Pin for external Resistor
VGHM	24	O	Output for gate-high modulation
VGH	25	I	Input for positive Charge Pump
FBP	26	I	Positive charge pump feedback pin
DRVP	27		Voltage driver of positive charge pump
SUP	28	I	Supply pin of the gate shaping and operational amplifier blocks. Connected as well to the overvoltage protection comparator. This pin needs to be connected to the output of the AVDD boost converter.
OPO	29	O	Output voltage of VCOM Buffer
OPI	30	I	Input voltage of VCOM Buffer
FB	31	I	AVDD Boost converter feedback pin
FREQ	32	I	AVDD boost converter switching frequency selection: 1.2MHz when $V_{(FREQ)} = V_{IN}$ and 650 kHz when $V_{(FREQ)} = \text{ground}$
PGND	ePAD		Exposed pad that serves as the power ground for both boost converters



BLOCK DIAGRAM

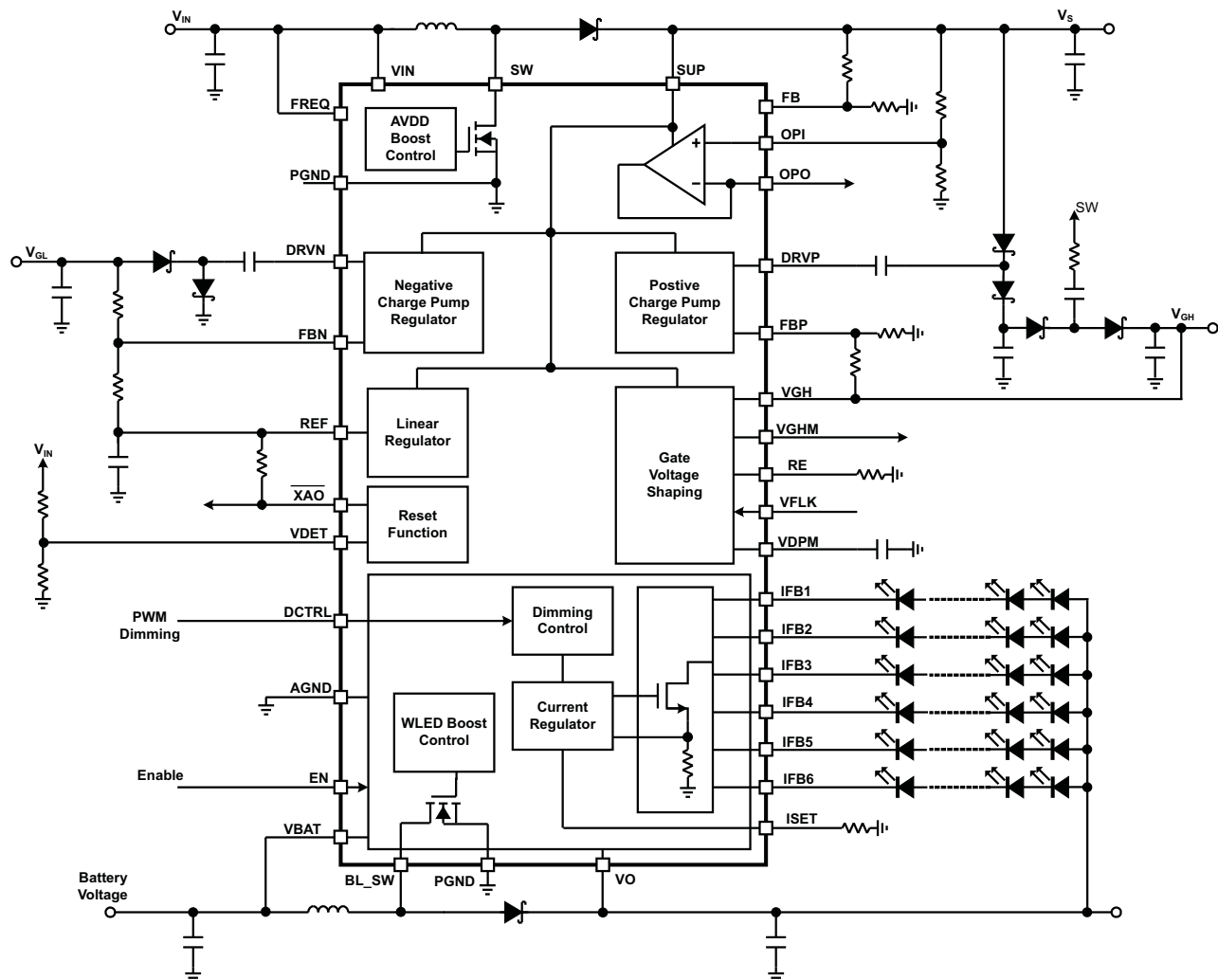

**TYPICAL CHARACTERISTICS**
**TABLE OF GRAPHS**

NAME	CONDITIONS	FIGURE
<b>BOOST CONVERTER (AVDD)</b>		
Efficiency vs. Load Current	$V_{IN} = 3.3\text{ V}$ , $V_S = 9\text{ V}$ , $L = 6.8\text{ }\mu\text{H}$ , $f = 1.2\text{ MHz}$	<a href="#">Figure 1</a>
Load Transient Response	$V_{IN} = 3.3\text{ V}$ , $V_S = 9\text{ V}$ , $I_S = 50\text{ mA}$ to $250\text{ mA}$	<a href="#">Figure 2</a>
Switch Node (SW) Wave form	CCM Operation, $V_{IN} = 3.3\text{ V}$ , $V_S = 9\text{ V}$ , $I_S = 200\text{ mA}$ , $V_{GH} = 24\text{ V}$ , $I_{GH} = 10\text{ mA}$	<a href="#">Figure 3</a>
	DCM Operation, $V_{IN} = 3.3\text{ V}$ , $V_S = 9\text{ V}$ , $I_S = 5\text{ mA}$ , $V_{GH} = 24\text{ V}$ , $I_{GH} = 1\text{ mA}$	<a href="#">Figure 4</a>
<b>POSITIVE CHARGE PUMP (<math>V_{GH}</math>)</b>		
Output Voltage Ripple	$V_{IN} = 3.3\text{ V}$ , $V_{GH} = 24\text{ V}$ , $I_{GH} = 20\text{ mA}$ , $V_S = 9\text{ V}$ , $I_S = 100\text{ mA}$	<a href="#">Figure 5</a>
Load Transient Response	$V_{IN} = 3.3\text{ V}$ , $V_{GH} = 21.5\text{ V}$ , $I_{GL} = 5\text{ mA}$ to $15\text{ mA}$ , $V_S = 9\text{ V}$ , $I_S = 100\text{ mA}$	<a href="#">Figure 6</a>
Output Voltage vs Load Current	$V_{IN} = 4.2\text{ V}$ , $V_{GH} = 24\text{ V}$ , $V_S = 14\text{ V}$	<a href="#">Figure 7</a>
<b>NEGATIVE CHARGE PUMP (<math>V_{GL}</math>)</b>		
Output Voltage Ripple	$V_{IN} = 3.3\text{ V}$ , $V_{GL} = -5.8\text{ V}$ , $I_{GL} = 20\text{ mA}$ , $V_S = 9\text{ V}$ , $I_S = 100\text{ mA}$	<a href="#">Figure 8</a>
Load Transient Response	$V_{IN} = 3.3\text{ V}$ , $V_{GL} = -5.8\text{ V}$ , $I_{GL} = 5\text{ mA}$ to $15\text{ mA}$ , $V_S = 9\text{ V}$ , $I_S = 100\text{ mA}$	<a href="#">Figure 9</a>
Output Voltage vs Load Current	$V_{IN} = 4.2\text{ V}$ , $V_{GL} = -6\text{ V}$ , $V_S = 9\text{ V}$	<a href="#">Figure 10</a>
<b>POWER ON SEQUENCING</b>		
Power On Sequence	$V_{IN} = 3.3\text{ V}$ , $V_S = 9\text{ V}$ , $V_{GH} = 24\text{ V}$ , $V_{GL} = -5.8\text{ V}$	<a href="#">Figure 11</a>
Power Off Sequence	$V_{IN} = 3.3\text{ V}$ , $V_S = 9\text{ V}$ , $V_{GH} = 24\text{ V}$ , $V_{GL} = -5.8\text{ V}$	<a href="#">Figure 12</a>
Power On Sequence of VGHM	$V_{IN} = 3.3\text{ V}$ , $V_{GH} = 24\text{ V}$ , $C_{(VDPM)} = 100\text{ nF}$ , $RE = 80\text{ K}\Omega$	<a href="#">Figure 13</a>
Power Off Sequence of VGHM	$V_{IN} = 3.3\text{ V}$ , $V_{GH} = 24\text{ V}$ , $C_{(VDPM)} = 100\text{ nF}$ , $RE = 80\text{ K}\Omega$	<a href="#">Figure 14</a>
Gate Voltage Shaping	$V_{IN} = 3.3\text{ V}$ , $V_{GH} = 24\text{ V}$ , $f_{(VFLK)} = 10\text{ KHz}$ , $RE = 80\text{ K}\Omega$	<a href="#">Figure 15</a>
Reset ( $\overline{XA0}$ )	$V_{IN} = 3.3\text{ V}$ , $V_{IN(LIM)} = 2.7\text{ V}$	<a href="#">Figure 16</a>
<b>WLED DRIVER</b>		
Load Efficiency of WLED Driver	$V_{BAT} = 10\text{ V}$ , $V_{OUT} = 19\text{ V}$ , $25\text{ V}$ and $33\text{ V}$ , $L = 10\text{ }\mu\text{H}$	<a href="#">Figure 17</a>
Load Efficiency of WLED Driver	$V_{BAT} = 10\text{ V}$ , $15\text{ V}$ and $19\text{ V}$ , $V_{OUT} = 35\text{ V}$ , $L = 10\text{ }\mu\text{H}$	<a href="#">Figure 18</a>
Dimming Linearity	$V_{BAT} = 10\text{ V}$ , $I_{OUT} = 120\text{ mA}$ , PWM Freq $100\text{ Hz}$	<a href="#">Figure 19</a>
Dimming Linearity	$V_{BAT} = 15\text{ V}$ , $I_{OUT} = 120\text{ mA}$ , PWM Freq $1\text{ kHz}$	<a href="#">Figure 20</a>
Switching Waveform	$V_{BAT} = 12\text{ V}$ , $V_{OUT} = 30.6\text{ V}$ , Duty $100\%$ , $C_O = 4.7\text{ }\mu\text{F}$	<a href="#">Figure 21</a>
Output Ripple at PWM Dimming	$V_{BAT} = 12\text{ V}$ , $V_{OUT} = 30.6\text{ V}$ , Duty $50\%$ , $C_O = 4.7\text{ }\mu\text{F}$	<a href="#">Figure 22</a>
Power On Sequence	$V_{BAT} = 12\text{ V}$ , $I_{SET} = 20\text{ }\mu\text{A}$	<a href="#">Figure 23</a>
Open LED Protection	$V_{BAT} = 12\text{ V}$ , $I_{SET} = 20\text{ }\mu\text{A}$	<a href="#">Figure 24</a>

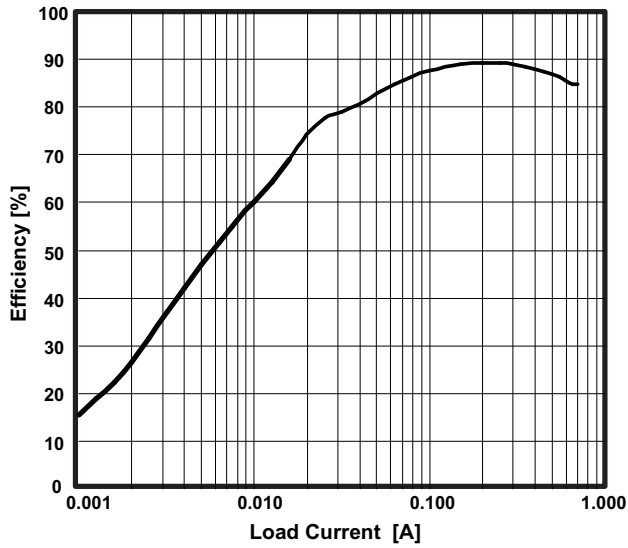

Figure 1. BOOST CONVERTER EFFICIENCY vs OUTPUT CURRENT

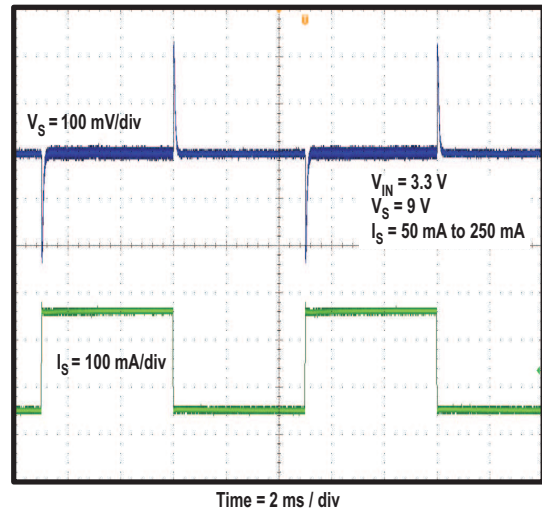

Figure 2. BOOST CONVERTER LOAD TRANSIENT RESPONSE

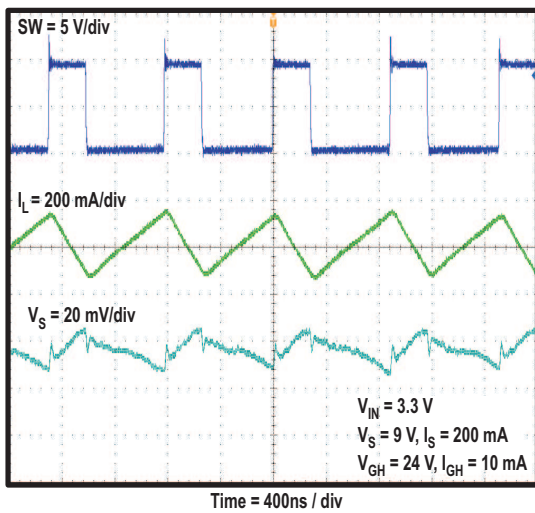

Figure 3. BOOST CONVERTER CONTINUOUS CONDUCTION MODE

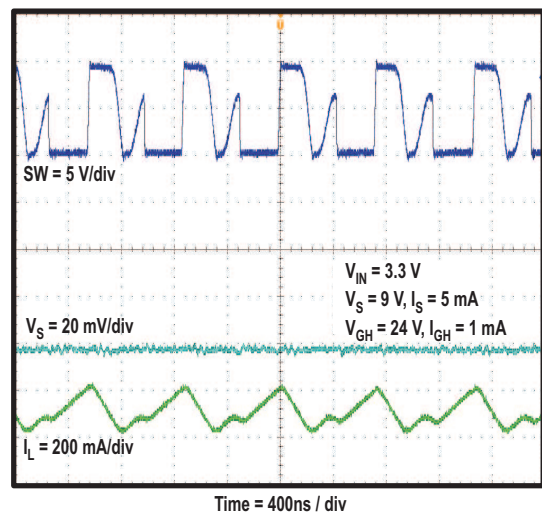

Figure 4. BOOST CONVERTER DISCONTINUOUS CONDUCTION MODE

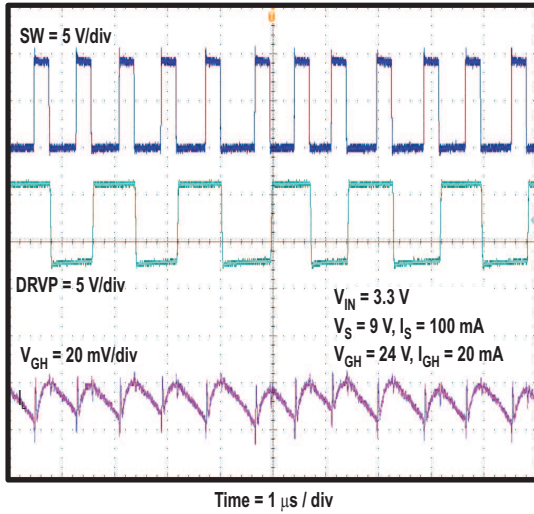

Figure 5. POSITIVE CHARGE PUMP OUTPUT VOLTAGE RIPPLE

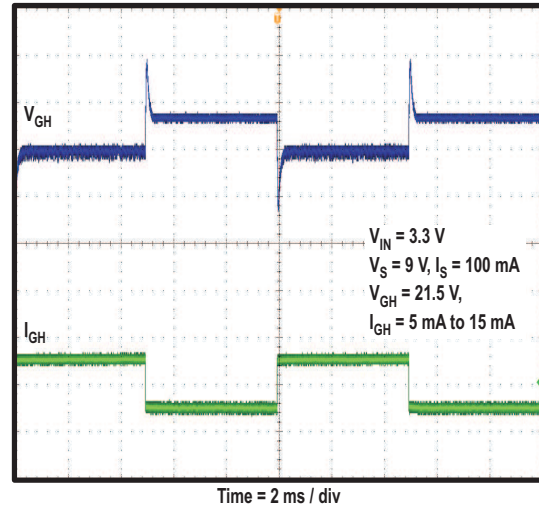

Figure 6. POSITIVE CHARGE PUMP LOAD TRANSIENT RESPONSE

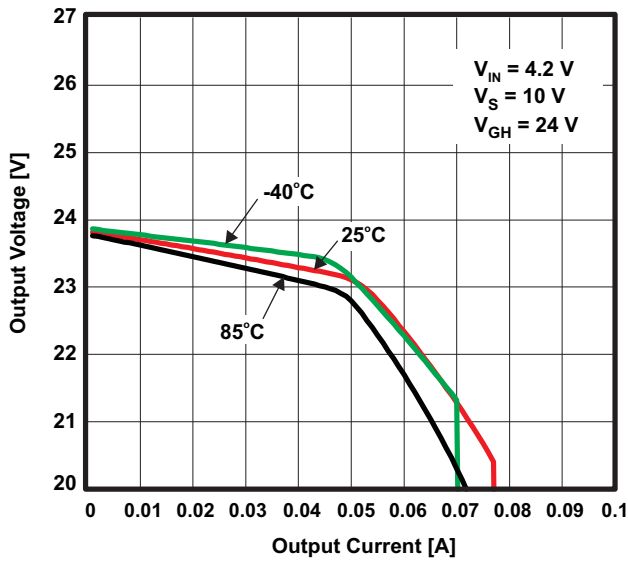

Figure 7. POSITIVE CHARGE PUMP VOLTAGE vs LOAD CURRENT

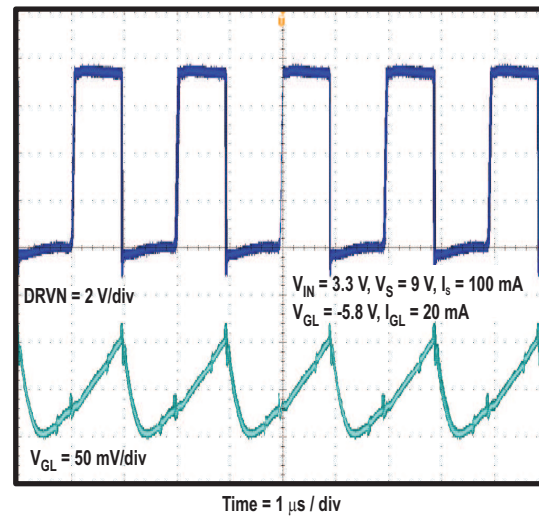

Figure 8. NEGATIVE CHARGE PUMP OUTPUT VOLTAGE RIPPLE

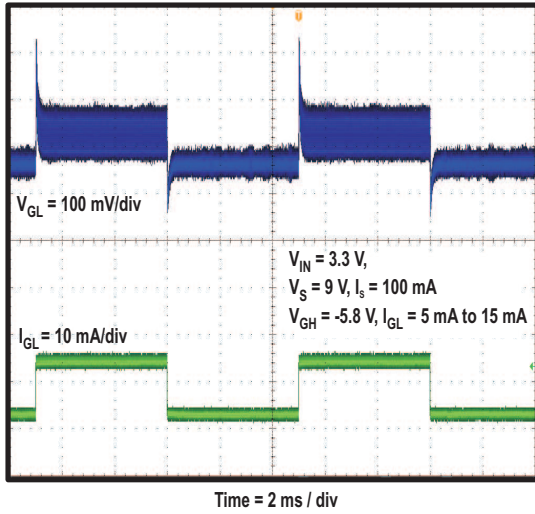

Figure 9. NEGATIVE CHARGE PUMP LOAD TRANSIENT RESPONSE

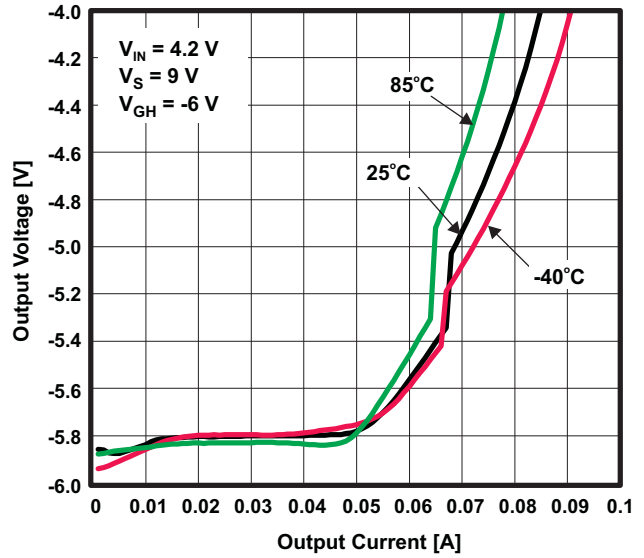

Figure 10. NEGATIVE CHARGE PUMP VOLTAGE vs LOAD CURRENT

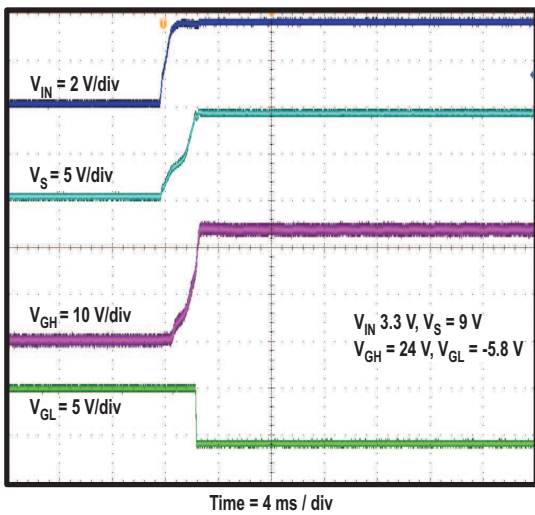

Figure 11. POWER ON SEQUENCE

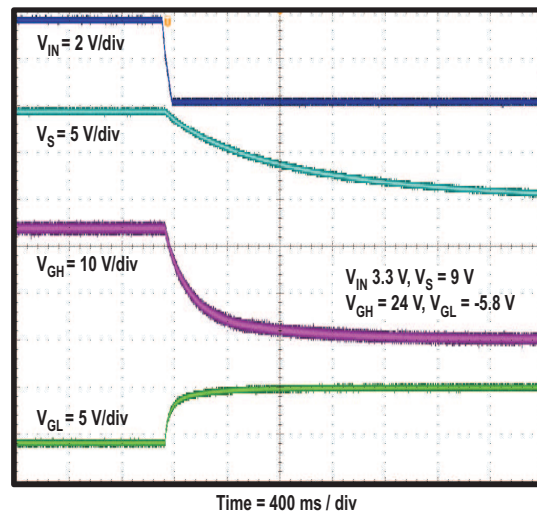

Figure 12. POWER OFF SEQUENCE

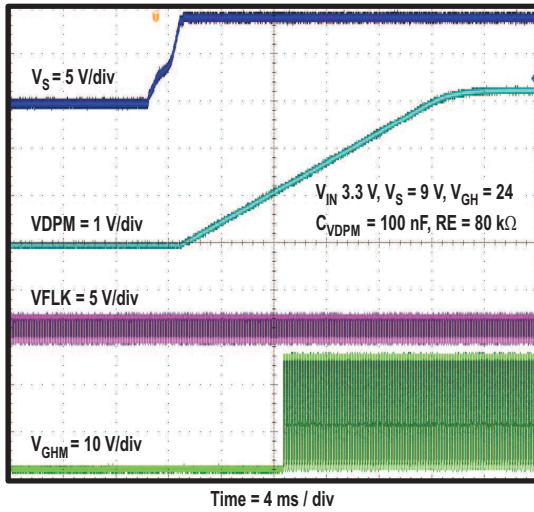

Figure 13. POWER ON SEQUENCE OF VGHM

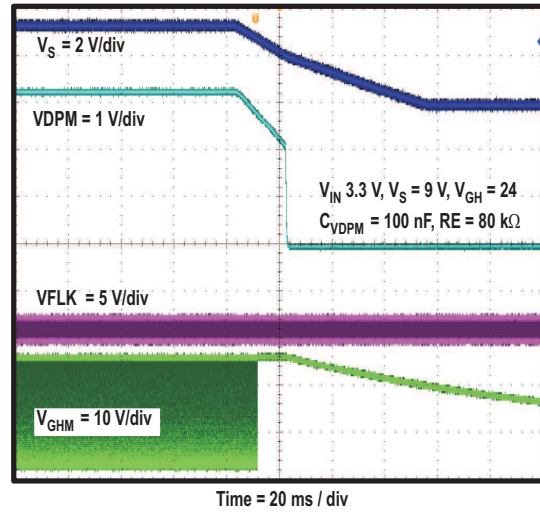

Figure 14. POWER OFF SEQUENCE OF VGHM

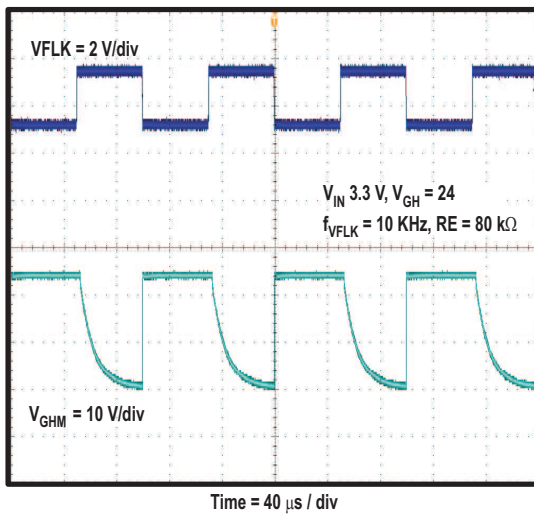

Figure 15. GATE VOLTAGE SHAPING

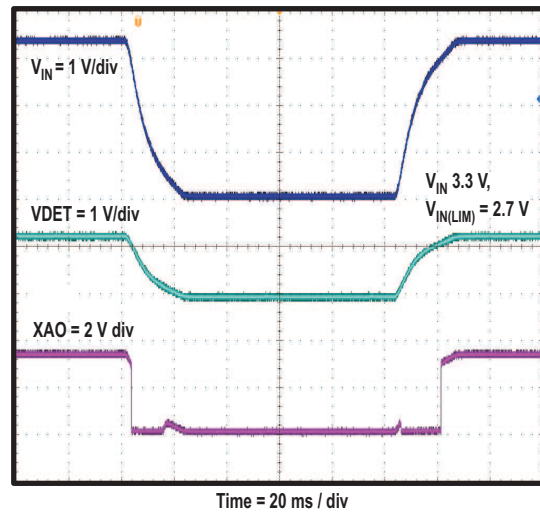

Figure 16. XAO SIGNAL

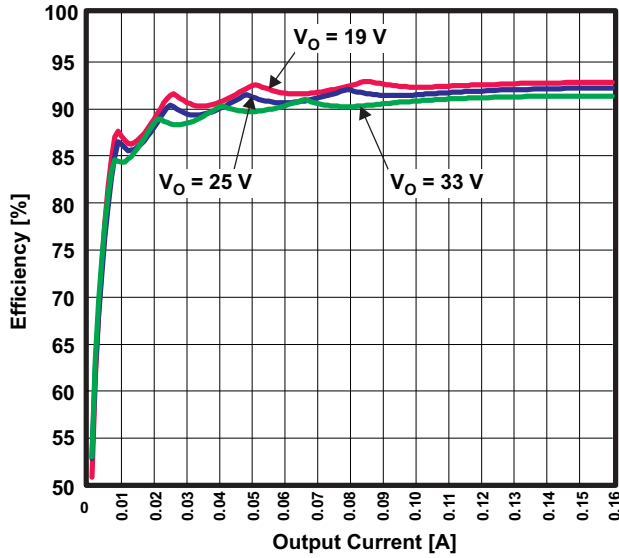

Figure 17. LED DRIVER EFFICIENCY vs OUTPUT CURRENT

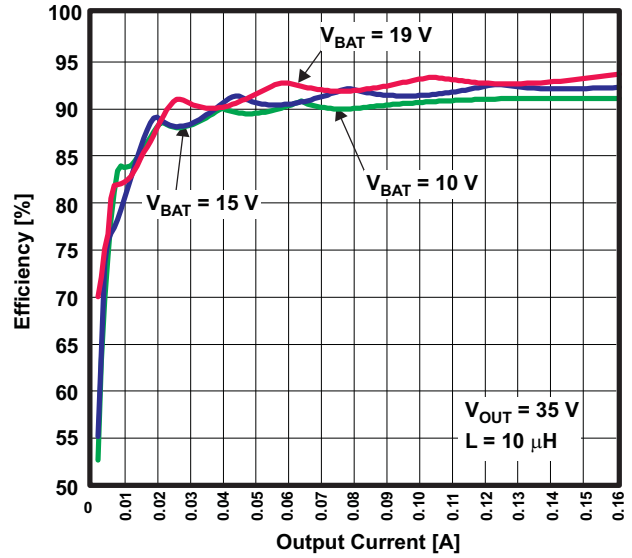

Figure 18. LED DRIVER EFFICIENCY vs OUTPUT CURRENT

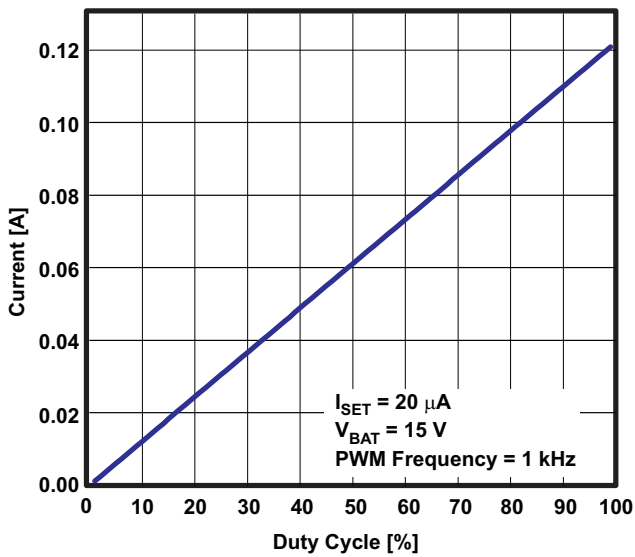

Figure 19. LED DRIVER PWM DIMMING LINEARITY 100Hz

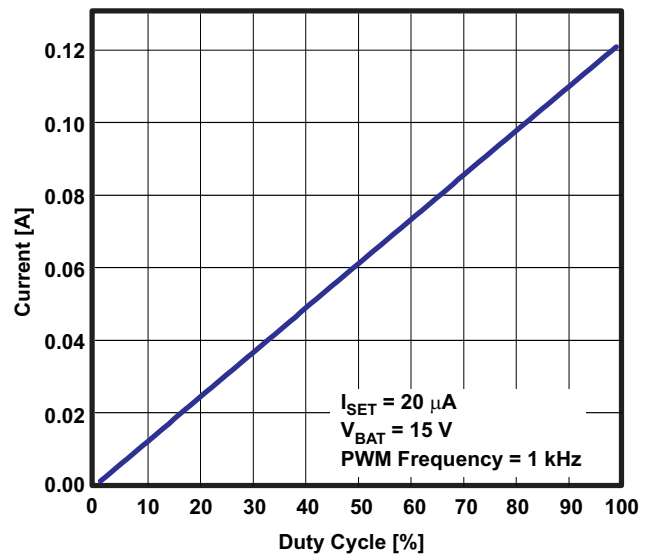

Figure 20. LED DRIVER PWM DIMMING LINEARITY 1kHz

TPS65142

SLVSAX5 – JULY 2011

www.ti.com

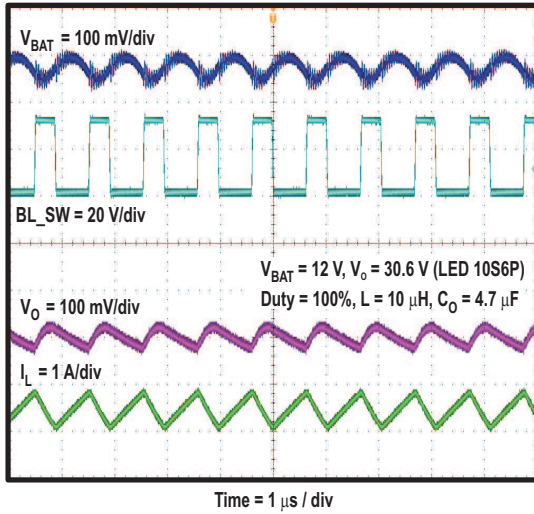

Figure 21. LED DRIVER SWITCHING WAVEFORM

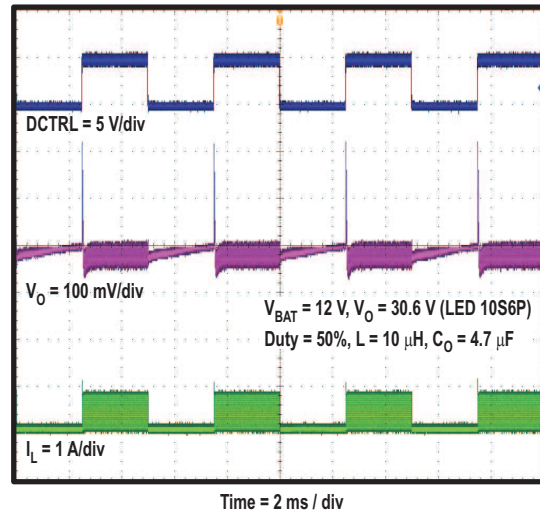

Figure 22. LED DRIVER OUTPUT RIPPLE AT PWM DIMMING

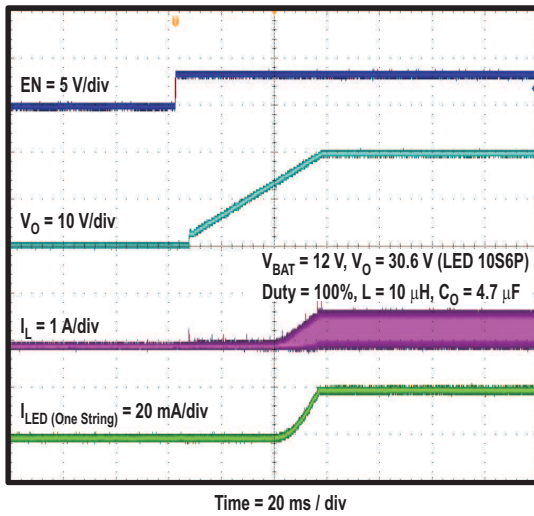

Figure 23. LED DRIVER POWER ON SEQUENCE

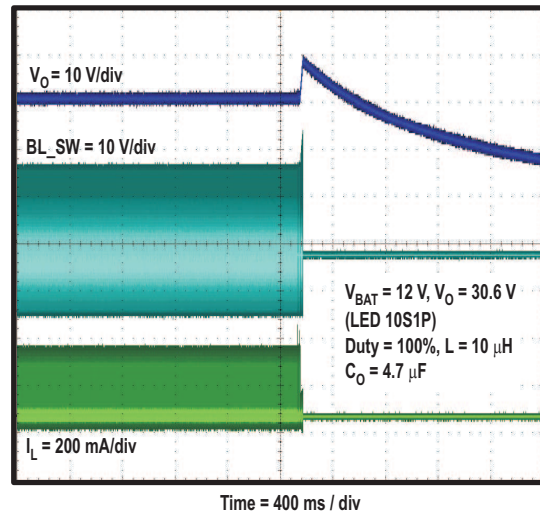

Figure 24. LED DRIVER OPEN WLED PROTECTION



## FUNCTIONAL DESCRIPTION

The TPS65142 offers a compact and complete solution to the bias power and the WLED backlight in note-pc TFT-LCD panels. The device features an AVDD boost regulator, a positive charge pump regulator, and a negative charge pump regulator to power the source drivers and the gate drivers. A 150 mA unity-gain high-speed buffer is provided to drive the VCOM plane. Gate voltage shaping and the LCD discharge function are offered to improve the image quality. A reset function allows a proper reset of the TCON at power on or the gate driver ICs during power off. The TPS65142 also includes the complete solution to drive up to 6 chains of WLEDs with 1000:1 ratio PWM dimming.

### AVDD BOOST REGULATOR

The AVDD boost regulator is designed for output voltages up to 16.5 V with a switch peak current limit of 1.8 A minimum. The device, which operates in a current-mode scheme with quasi-constant frequency, is internally compensated to minimize the pin and component counts. The switching frequency is selectable between 650 kHz and 1.2 MHz and the minimum input voltage is 2.3 V.

During the on-time, the current rises in the inductor. When the current reaches a threshold value set by the internal GM amplifier, the power transistor is turned off. The polarity of the inductor voltage changes and forward biases the Schottky diode, which lets the current flow towards the output of the boost regulator. The off-time is fixed for a certain input voltage  $V_{IN}$  and output voltage  $V_S$ , and therefore maintains the same frequency when varying these parameters. However, for different output loads, the frequency changes slightly due to the voltage drop across the  $r_{DS(ON)}$  of the power transistor which will have an effect on the voltage across the inductor and thus on  $t_{ON}$  ( $t_{OFF}$  remains fixed).

The fixed off-time maintains a quasi-fixed frequency that provides better stability for the system over a wide range of input and output voltages than conventional boost converters. The TPS65142 topology has also the benefits of providing very good load and line regulations, and excellent line and load transient responses.

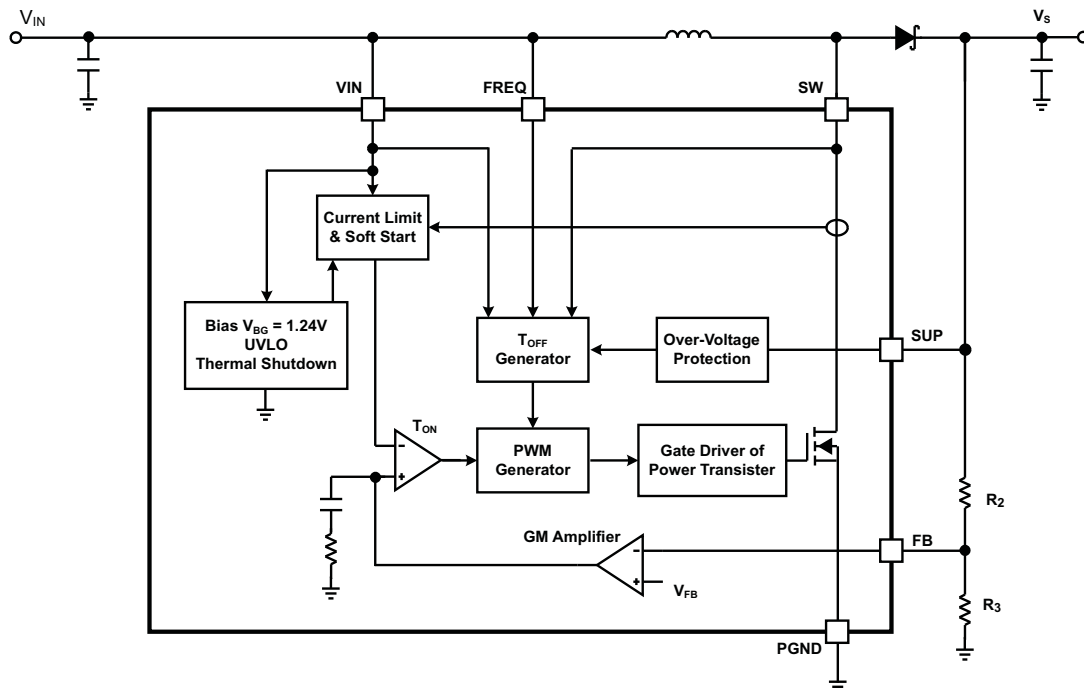

Figure 25. Boost Converter Block Diagram

### Setting the Output Voltage

The output voltage is set by an external resistor divider. Typically, a minimum current of 50  $\mu$ A flowing through the feedback divider is enough to cover the noise fluctuation. If 70  $\mu$ A is chosen for higher noise immunity, the resistors shown in Figure 25 are then calculated as:

$$R_3 = \frac{V_{FB}}{70 \mu A} \approx 18.2 \text{ k}\Omega \quad R_2 = R_3 \times \left( \frac{V_S}{V_{FB}} - 1 \right) \quad (1)$$

where  $V_{FBP} = 1.240 \text{ V}$

### Soft-Start (AVDD Boost Converter)

The AVDD boost converter has an internal digital soft-start to prevent high inrush current during start-up. The typical soft-start time is 2ms.

### Frequency Select Pin (FREQ)

The digital frequency-select pin FREQ allows to set the switching frequency of the device to 650 kHz (FREQ = low) or 1.2MHz (FREQ = high). Higher switching frequency improves load transient response but reduces slightly the efficiency. The other benefit of a higher switching frequency is the lower output voltage ripple. Usually, it is recommended to use 1.2 MHz switching frequency unless light load efficiency is a major concern.

### Overvoltage Protection

The AVDD boost converter has an integrated over-voltage protection to prevent the power switch from exceeding the absolute maximum switch voltage rating at pin SW in case the feedback (FB) pin is floating or shorted to GND. In such an event, the output voltage rises and is monitored with the overvoltage protection comparator over the SUP pin. As soon as the comparator trips at typically 18 V, the boost converter turns the N-Channel MOSFET switch off. The output voltage falls below the overvoltage threshold and the converter continues to operate. In order to detect overvoltage, the SUP pin must be connected to the output voltage of the boost converter  $V_S$ .

### Regulated Positive Charge Pump

The positive charge pump sets the voltage applied on the VGH input pin, up to 32 V in tripler mode configuration. The charge pump block regulates the VGH voltage by adjusting the drive current  $I_{DRVP}$ . Typically, a minimum current of 50  $\mu A$  flowing through the feedback divider is usually enough to cover the noise fluctuation. If 70  $\mu A$  is chosen for higher noise immunity, the resistors of the divider used to set the  $V_{GH}$  voltage are calculated as (refer to Figure 26):

$$R_8 = \frac{V_{FBP}}{70 \mu A} \approx 18.2 \text{ k}\Omega \quad R_7 = R_8 \times \left( \frac{V_{GH}}{V_{FBP}} - 1 \right) \quad (2)$$

where  $V_{FBP} = 1.240 \text{ V}$

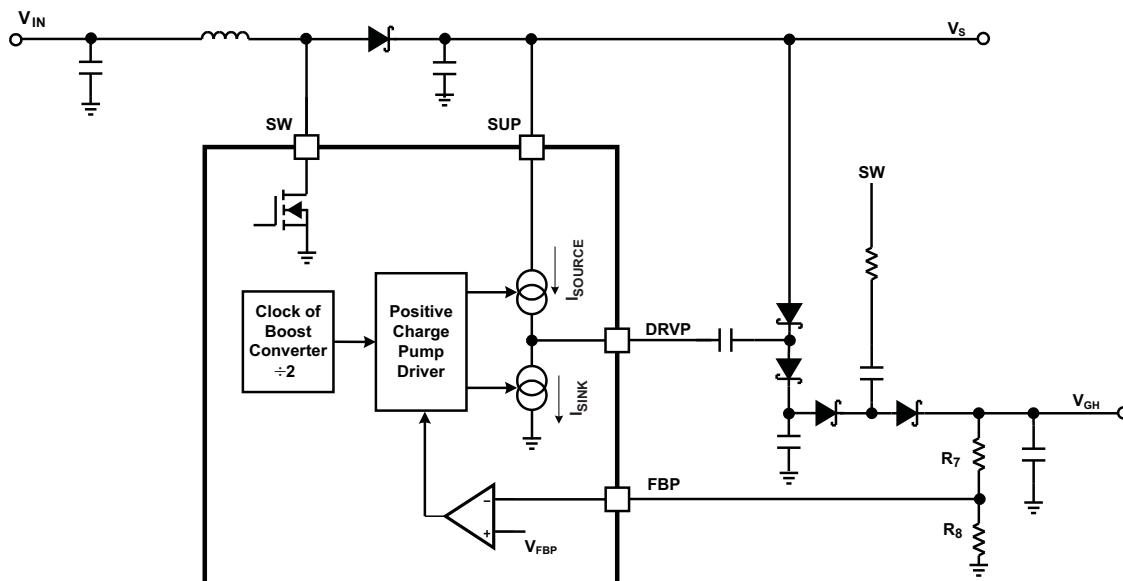

**Figure 26. Block Diagram of the Positive Charge Pump Regulator**

## Negative Charge Pump

Figure 27 shows the block diagram of the negative charge pump. The negative charge pump needs to generate a voltage of  $-6\text{ V}$  to  $-7\text{ V}$  with a negative inverter or  $-12\text{ V}$  to  $-13\text{ V}$  with a negative doubler. The reference voltage from the REF pin is  $3.15\text{ V}$ . The bias to the REF block comes from the SUP pin. The error amplifier is referenced to the ground. The  $V_{GL}$  can be set with the following equation:

$$V_{GL} = -\frac{R_4}{R_5} \times V_{REF} \tag{3}$$

where  $V_{REF} = 3.15\text{ V}$

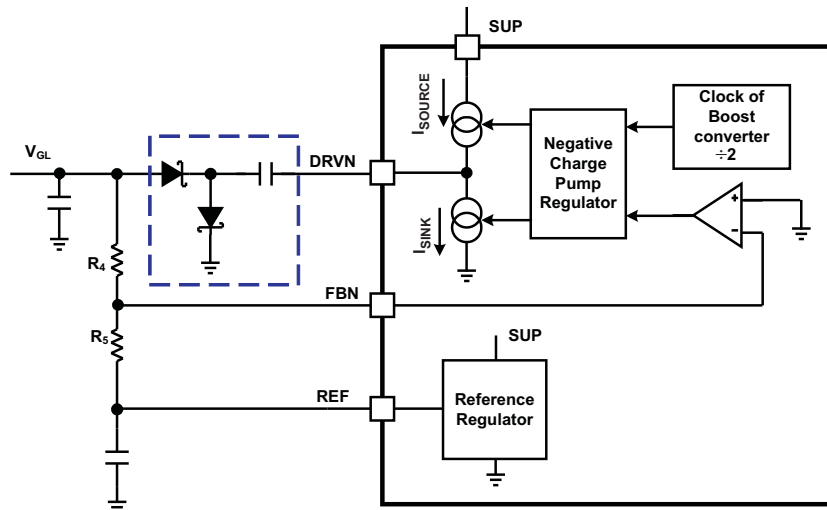

Figure 27. Block Diagram of the Negative Charge Pump Regulator with a Negative Inverter Configuration

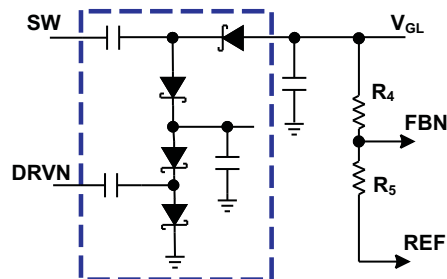

Figure 28. Negative Doubler Configuration for the Negative Charge Pump Regulator

## Gate Voltage Shaping

The VGHM output is controlled by the VFLK logic input and the VDPM voltage level.

The VDPM pin allows the user to set a delay before the Gate Voltage Shaping starts. The voltage of the VDPM pin is zero volt at power on. When the output voltage of the AVDD boost converter rises above a power-good threshold, a power-good signal enables a  $20\ \mu\text{A}$  current source that charges the capacitor connected between the VDPM pin and the ground. When the VDPM-pin voltage rises to  $1.240\text{ V}$ , the Gate Voltage Shaping is enabled.

The VFLK input controls the M1 and the M2 transistors, as shown in Figure 29, after the Gate Voltage Shaping is enabled:

When VFLK = "low", M1 is turned on so VGHM is connected to the VGH input.

When VFLK = "high", M2 is turned on so VGHM voltage is discharged through M2 and the resistor connected to the RE pin.

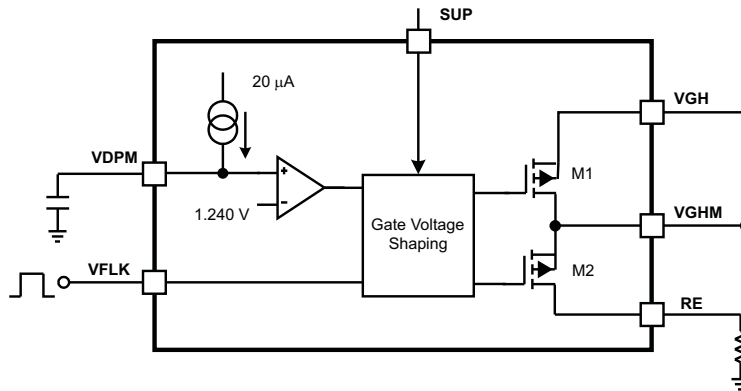

Figure 29. Block Diagram of the Gate Voltage Shaping Function

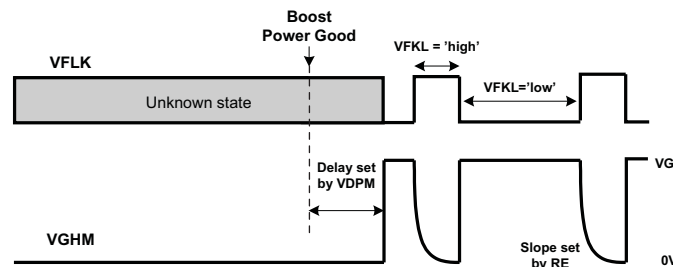

Figure 30. Gate Voltage Shaping Timing

### VCOM Buffer

The VCOM Buffer power supply pin is the SUP pin connected to the AVDD boost converter  $V_S$ . To achieve good performance and minimize the output noise, a 1- $\mu$ F ceramic bypass capacitor is required directly from the SUP pin to ground. The buffer is not designed to drive high capacitive loads; therefore, it is recommended to connect a series resistor at the output to provide stable operation when driving a high capacitive load. With a 3.3- $\Omega$  series resistor, a capacitive load of 10 nF can be driven, which is usually sufficient for typical LCD applications.

### Reset

The device has an integrated reset function with an open-drain output capable of sinking 1 mA. The reset function monitors the voltage applied to its sense input  $V_{(DET)}$ . As soon as the voltage on  $V_{(DET)}$  falls below the threshold voltage,  $V_{(DET)}$ , of typically 1.1 V, the reset function asserts its reset signal by pulling  $\overline{XAO}$  low. Typically, a minimum current of 50  $\mu$ A flowing through the feedback divider is enough to cover the noise fluctuation. Therefore, to select  $R_{12}$  and  $R_{13}$  (see Figure 33), one has to set the input voltage limit ( $V_{IN(LIM)}$ ) at which the reset function will pull  $\overline{XAO}$  to low state.  $V_{IN(LIM)}$  must be higher than the UVLO threshold. If 70  $\mu$ A is chosen,

$$R_{13} = \frac{V_{(DET)}}{70 \mu A} \approx 18.2 \text{ k}\Omega \quad R_{12} = R_{13} \times \left( \frac{V_{IN(LIM)}}{V_{(DET)}} - 1 \right) \quad (4)$$

where  $V_{DET} = 1.1 \text{ V}$ .

The  $\overline{XAO}$  output is also controlled by the UVLO function. When the input voltage is below the UVLO threshold,  $\overline{XAO}$  output is forced low until the input voltage is lower than 1.6 V. The  $\overline{XAO}$  output is in an unknown state when the input voltage is below the 1.6 V threshold.

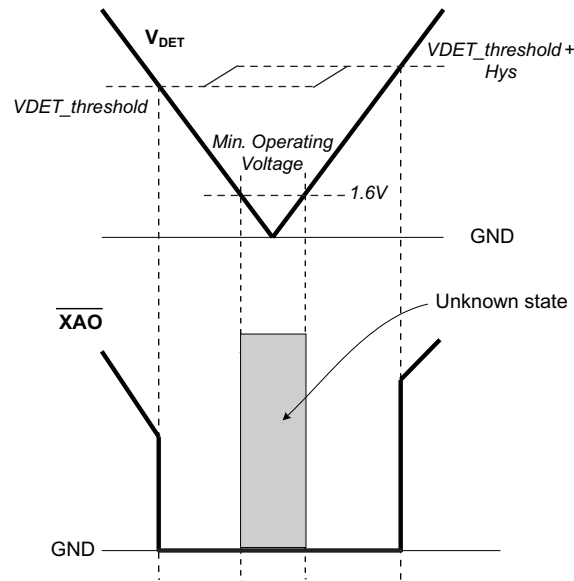

Figure 31. Voltage Detection and  $\overline{\text{XAO}}$  Pin

When the input voltage  $V_{IN}$  rises, once the voltage on VDET pin exceeds its threshold voltage plus the hysteresis, the  $\overline{\text{XAO}}$  signal will go high.

The reset function is operational for  $V_{IN} \geq 1.6 \text{ V}$ .

The reset function is configured as a standard open-drain and requires a pull-up resistor. The resistor  $R_{(\overline{\text{XAO}})}$  ( $R_{14}$  in Figure 33), which must be connected between the  $\overline{\text{XAO}}$  pin output and a positive voltage  $V_X$  greater than 2 V – 'high' logic level can be chosen as follows:

$$R_{14} > \frac{V_X}{1 \text{ mA}} \quad \text{and} \quad R_{14} < \frac{V_X - 2 \text{ V}}{2 \mu\text{A}} \quad (5)$$

### Under-voltage Lockout (UVLO)

The TPS65142 monitors both  $V_{IN}$  and  $V_{BAT}$  inputs for under-voltage lockout. When the  $V_{IN}$  input is under its UVLO threshold, the whole IC is disabled to avoid mis-operation. When the  $V_{IN}$  input rises above its UVLO threshold, all functions are enabled except the WLED driver. The WLED driver, including the WLED boost converter and the current sinks, will be enabled when the  $V_{BAT}$  input is also higher than its UVLO threshold.

### Thermal Shutdown

A thermal shutdown is implemented to prevent damages because of excessive heat and power dissipation. Typically the thermal shutdown threshold for the junction temperature is 150°C. When the thermal shutdown is triggered the device stops switching until the junction temperature falls below typically 136°C. Then the device starts switching again.

### WLED BOOST REGULATOR

The WLED boost regulator is a current-mode PWM regulator with internal loop compensation. The internal compensation ensures a stable output over the full input and output voltage range. The WLED boost regulator switches at fixed 1 MHz. The output voltage of the boost regulator is automatically set by the TPS65142 to minimize the voltage drop across the current-sink IFBx pins. The lowest IFB-pin voltage to regulate to 400 mV. When the output voltage is too close to the input, the WLED boost regulator may not be able to regulate the output due to the limitation of the minimum duty cycle. In that case, the user needs to increase the number of WLED in series or to include series ballast resistors to provide enough headroom for the boost converter to operate. The WLED boost regulator cannot regulate its output to a voltage below 15 V.

## Current Sinks

The six current sink regulators can each provide a maximum of 25 mA. The IFB current must be programmed to the highest WLED current expected using an ISET-pin resistor with the following equation:

$$I_{(FB)} = K_{(ISET)} \frac{V_{(ISET)}}{R_{(ISET)}} \quad (6)$$

where

- $K_{(ISET)}$  = Current multiple (1000 typical)
- $V_{(ISET)}$  = ISET pin voltage (1.229 V typical)
- $R_{(ISET)}$  = ISET-pin resistor value

The TPS65142 has built-in precise current sink regulators. The current matching error among 6 current sinks is below 2.5%. This means the differential values between the maximum and minimum currents of the six current sinks divided by the average current of the six is less than 2.5%.

## Unused IFB Pins

If the application requires less than 6 WLED strings, one can easily disable unused IFB pins by simply leaving the unused IFB pin open or shorting it to ground. If the IFB pin is open, the boost output voltage ramps up to  $V_O$  overvoltage threshold during start up. The IC then detects the zero current string and removes it from the feedback loop. If the IFB pin is shorted to ground, the IC detects the short immediately after WLED driver is enable, and the boost output voltage does not go up to  $V_O$  overvoltage threshold. Instead, it ramps to the regulation voltage after the soft start.

## PWM Dimming

The WLED brightness is controlled by the PWM signal on the DCTRL pin. The frequency and duty cycle of the DCTRL signal is replicated on the IFB pin current. Keep the dimming frequency in the range of 100 Hz to 1 kHz to avoid screen flickering and to maintain dimming linearity. Screen flickering may occur if the dimming frequency is below the range. The minimum achievable duty cycle increases with the dimming frequency. For example, while a 0.1% dimming duty cycle, giving a 1000:1 dimming range, is achievable at 100 Hz dimming frequency, only 1% duty cycle, giving a 100:1 dimming range, is achievable with a 1 kHz dimming frequency, and 5% dimming duty cycle is achievable with 5 kHz dimming frequency. The device can work at high dimming frequency such as 20KHz, but then only 15% duty cycle can be achieved. The TPS65142 is designed to minimize the AC ripple on the output capacitor during PWM dimming. Careful passive component selection is also critical to minimize AC ripple on the output capacitor.

## ENABLING THE WLED DRIVER

The WLED driver (including the WLED boost converter and the six current sinks) is enabled when all following four conditions are satisfied:

1. the VBAT input voltage is higher than its under-voltage-lockout (UVLO) threshold;
2. the REF regulator output is higher than its power-good threshold;
3. the output voltage  $V_O$  is within 2V of the input voltage  $V_{BAT}$ ;
4. and the enable input from the EN pin is high.

Pulling the EN pin low shuts down the WLED driver.

## SOFT-START of WLED BOOST REGULATOR

Once the above four conditions are satisfied, the WLED boost converter begins the internal soft-start. The soft-start function gradually ramps up the reference voltage of the error amplifier to prevent the output-voltage over shoot and inrush current from the VBAT input.

## Protection of WLED Driver

The TPS65142 has multiple protection mechanisms to secure the safe operation of the WLED driver.

## Current Limit Protection

The WLED boost regulator switching MOSFET has a pulse-by-pulse over-current limit of 1.5 A (minimum value). The PWM switch turns off when the inductor current reaches this current threshold and remains off until the beginning of the next switching cycle. This protects the IC and external components under over-load conditions. When there is sustained overcurrent condition for more than 16 ms (under 100% dimming duty cycle), the IC turns off and requires VBAT POR or the EN pin toggling to restart.

Under severe over load and/or short-circuit conditions, the VO pin can be pulled below the input (VBAT pin voltage). Under this condition, the current can flow directly from the input to the output through the inductor and the Schottky diode. Turning off the PWM switch alone does not limit current anymore. In this case, the TPS65142 relies on the fuse at the input to protect the whole system. When the TPS65142 detects the output voltage to be 1 V (short-circuit detection threshold) below the input voltage, it shuts down the WLED driver. The IC restarts after input power-on reset (VBAT POR) or EN pin logic toggling.

## Open WLED String Protection

If one of the WLED strings is open, the boost output rises to its over-voltage threshold (39V typically). The IC detects the open WLED string by sensing no current in the corresponding IFBx pin. As a result, the IC removes the open IFBx pin from the voltage feedback loop. The output voltage drops and is regulated to the voltage for the remaining connected WLED strings. The IFBx current of the connected WLED string remains in regulation during the whole transition.

The IC shuts down if it detects that all of the WLED strings are open.

## Overvoltage Protection

If the overvoltage threshold is reached, but the current sensed on the IFBx pin is below the regulation target, the IC regulates the boost output at the overvoltage threshold. This operation could occur when the WLED is turned on under cold temperature, and the forward voltages of the WLEDs exceed the over-voltage threshold. Maintaining the WLED current allows the WLED to warm up and their forward voltages to drop below the overvoltage threshold.

If any IFBx pin voltage exceeds IFB overvoltage threshold (17 V typical), the IC turns off the corresponding current sink and removes this IFB pin from VO regulation loop. The remaining IFBx pins' current regulation is not affected. This condition often occurs when there are several shorted WLEDs in one string. WLED mismatch typically does not create such large voltage difference among WLED strings.

## POWER UP/DOWN SEQUENCE

The power up and power down sequences are shown in [Figure 32](#).

The operation of the bias converters are gated by the UVLO of the VIN voltage. The start-up of the WLED boost converter is gated by the UVLO of the VBAT input, the power good of the REF output, the (VBAT-2 V) and VO comparator output, and the EN input. The REF output is powered by the output of the AVDD boost converter through the SUP pin; and hence, the WLED boost converter will not start before the AVDD boost converter.

### Power Up Sequence

The power up sequence of the bias portion is as following. When the VIN rises above the ULVO threshold, and the internal device enable signal is asserted. The AVDD boost converter begins the soft-start, the REF regulator starts to rise, the VCOM buffer is enabled, and both charge pumps begins to operate. When the REF output reaches its regulation voltage, a VREF power good signal is asserted for the WLED section. The AVDD boost converter continues the soft start until its output voltage reaches the AVDD power good threshold when an AVDD power good signal is asserted. The AVDD power good signal enables the 20 $\mu$ A current to the VDPM pin to start the gate voltage shaping delay timer. The delay is programmed by the external capacitor connected to the VDPM pin and should be long enough to ensure that both charge pumps are ready before the delay ends. Once the delay ends, the gate voltage shaping (VGHM) output is enabled to be controlled by the VFLK input.

The power up sequence of the WLED driver section is as following. When the four conditions for the Enabling the WLED Driver section are satisfied, the WLED boost converter begins the soft start, together with the start of the current sinks. When any of the four conditions is not satisfied, the WLED boost converter will stop switching.

### Power Down Sequence and LCD Discharge Function

The power down sequence of the bias section is as following. When the input voltage  $V_{IN}$  falls below a predefined threshold set by  $V_{(DET\_THRESHOLD)}$ ,  $\overline{XAO}$  is driven low and the VGHM output is driven to  $V_{GH}$ . (Note that when  $V_{IN}$  falls below the UVLO threshold, all IC functions are disabled except  $\overline{XAO}$  and VGHM outputs). Since VGHM is connected to VGH, it tracks the output of the positive charge pump as it decays. This feature, together with  $\overline{XAO}$ , can be used to discharge the panel by turning on all the pixel TFTs and discharging them into the gradually decaying VGHM voltage. VHGM is held low during power-up.

The REF regulator will be disabled when  $V_{IN}$  falls below the UVLO threshold, hence, the WLED boost converter as well.

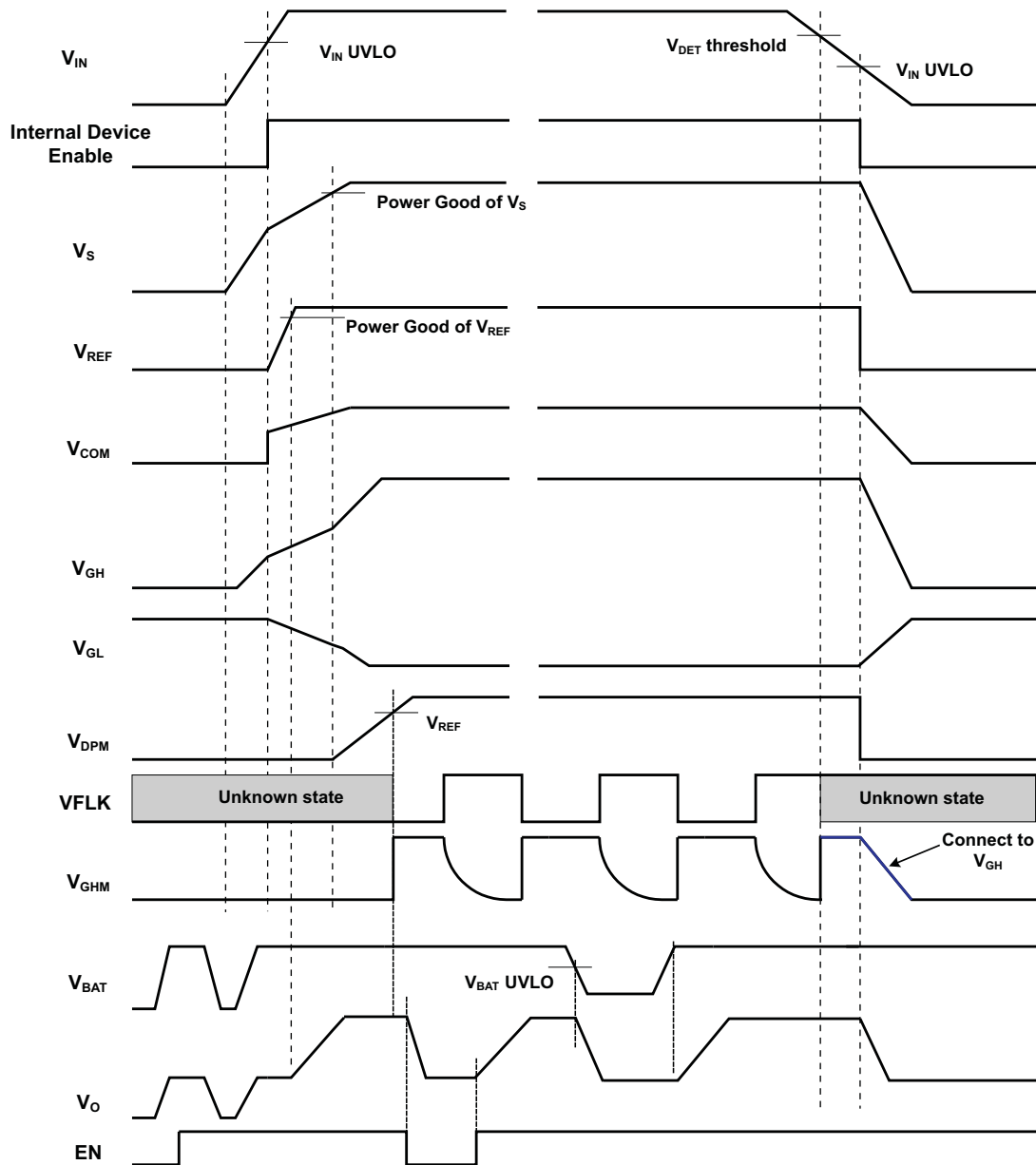

**Figure 32. Power Up/Down Sequence**



APPLICATION INFORMATION

This section describes the application information of various functions.

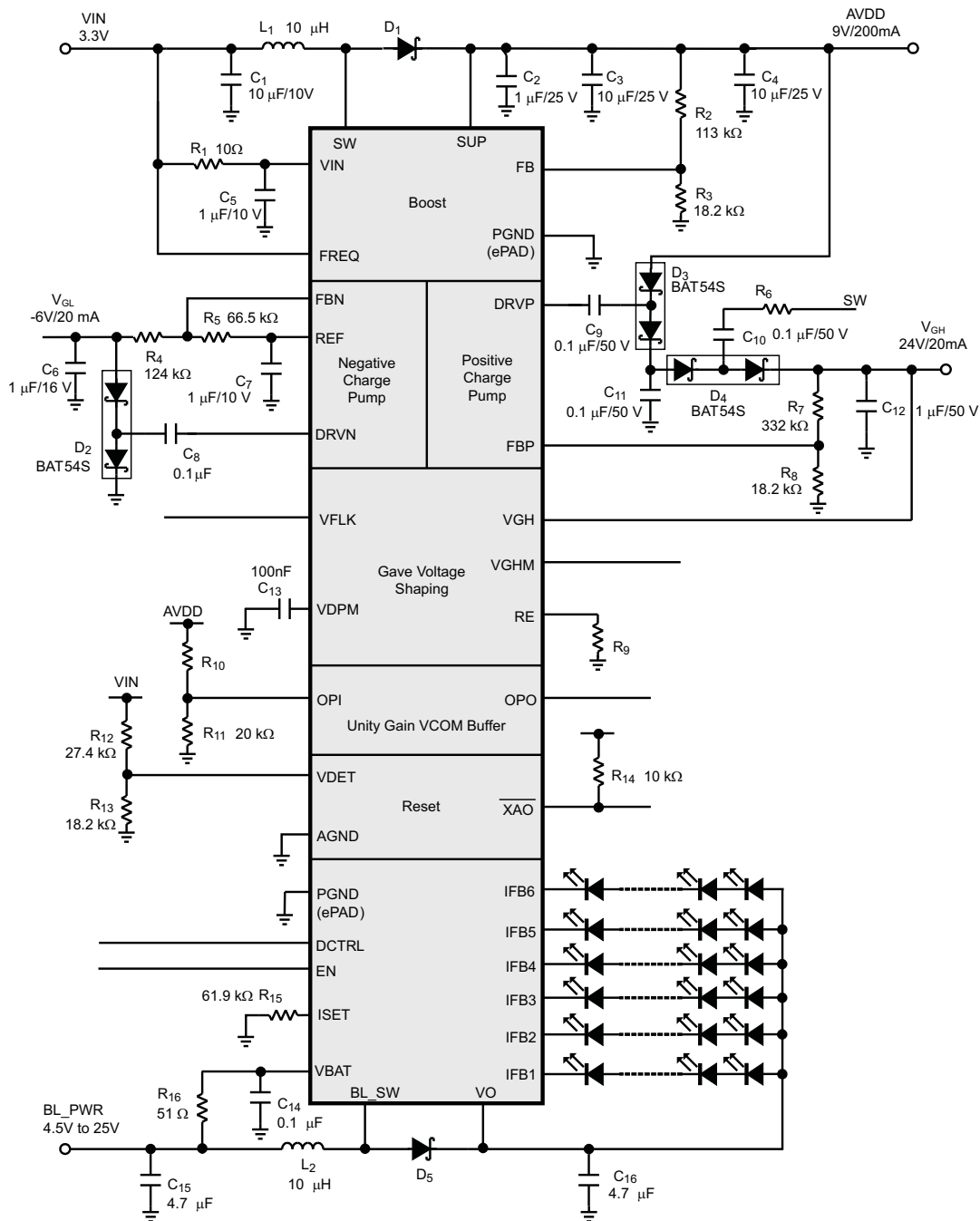

Figure 33. Typical Application Circuit

**PACKAGING INFORMATION**

Orderable Device	Status <sup>(1)</sup>	Package Type	Package Drawing	Pins	Package Qty	Eco Plan <sup>(2)</sup>	Lead/ Ball Finish	MSL Peak Temp <sup>(3)</sup>	Samples (Requires Login)
TPS65142RTGR	ACTIVE	WQFN	RTG	32	3000	Green (RoHS & no Sb/Br)	CU NIPDAU	Level-2-260C-1 YEAR	

<sup>(1)</sup> The marketing status values are defined as follows:

**ACTIVE:** Product device recommended for new designs.

**LIFEBUY:** TI has announced that the device will be discontinued, and a lifetime-buy period is in effect.

**NRND:** Not recommended for new designs. Device is in production to support existing customers, but TI does not recommend using this part in a new design.

**PREVIEW:** Device has been announced but is not in production. Samples may or may not be available.

**OBSOLETE:** TI has discontinued the production of the device.

<sup>(2)</sup> Eco Plan - The planned eco-friendly classification: Pb-Free (RoHS), Pb-Free (RoHS Exempt), or Green (RoHS & no Sb/Br) - please check <http://www.ti.com/productcontent> for the latest availability information and additional product content details.

**TBD:** The Pb-Free/Green conversion plan has not been defined.

**Pb-Free (RoHS):** TI's terms "Lead-Free" or "Pb-Free" mean semiconductor products that are compatible with the current RoHS requirements for all 6 substances, including the requirement that lead not exceed 0.1% by weight in homogeneous materials. Where designed to be soldered at high temperatures, TI Pb-Free products are suitable for use in specified lead-free processes.

**Pb-Free (RoHS Exempt):** This component has a RoHS exemption for either 1) lead-based flip-chip solder bumps used between the die and package, or 2) lead-based die adhesive used between the die and leadframe. The component is otherwise considered Pb-Free (RoHS compatible) as defined above.

**Green (RoHS & no Sb/Br):** TI defines "Green" to mean Pb-Free (RoHS compatible), and free of Bromine (Br) and Antimony (Sb) based flame retardants (Br or Sb do not exceed 0.1% by weight in homogeneous material)

<sup>(3)</sup> MSL, Peak Temp. -- The Moisture Sensitivity Level rating according to the JEDEC industry standard classifications, and peak solder temperature.

**Important Information and Disclaimer:** The information provided on this page represents TI's knowledge and belief as of the date that it is provided. TI bases its knowledge and belief on information provided by third parties, and makes no representation or warranty as to the accuracy of such information. Efforts are underway to better integrate information from third parties. TI has taken and continues to take reasonable steps to provide representative and accurate information but may not have conducted destructive testing or chemical analysis on incoming materials and chemicals. TI and TI suppliers consider certain information to be proprietary, and thus CAS numbers and other limited information may not be available for release.

In no event shall TI's liability arising out of such information exceed the total purchase price of the TI part(s) at issue in this document sold by TI to Customer on an annual basis.

**TAPE AND REEL INFORMATION**

**REEL DIMENSIONS**



**TAPE DIMENSIONS**

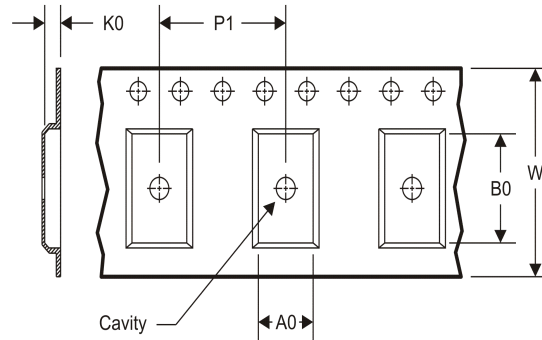

A0	Dimension designed to accommodate the component width
B0	Dimension designed to accommodate the component length
K0	Dimension designed to accommodate the component thickness
W	Overall width of the carrier tape
P1	Pitch between successive cavity centers

**TAPE AND REEL INFORMATION**

\*All dimensions are nominal

Device	Package Type	Package Drawing	Pins	SPQ	Reel Diameter (mm)	Reel Width W1 (mm)	A0 (mm)	B0 (mm)	K0 (mm)	P1 (mm)	W (mm)	Pin1 Quadrant
TPS65142RTGR	WQFN	RTG	32	3000	330.0	16.4	3.3	6.3	1.0	8.0	16.0	Q1

**TAPE AND REEL BOX DIMENSIONS**



\*All dimensions are nominal

Device	Package Type	Package Drawing	Pins	SPQ	Length (mm)	Width (mm)	Height (mm)
TPS65142RTGR	WQFN	RTG	32	3000	367.0	367.0	38.0

# MECHANICAL DATA

RTG (R-PWQFN-N32)

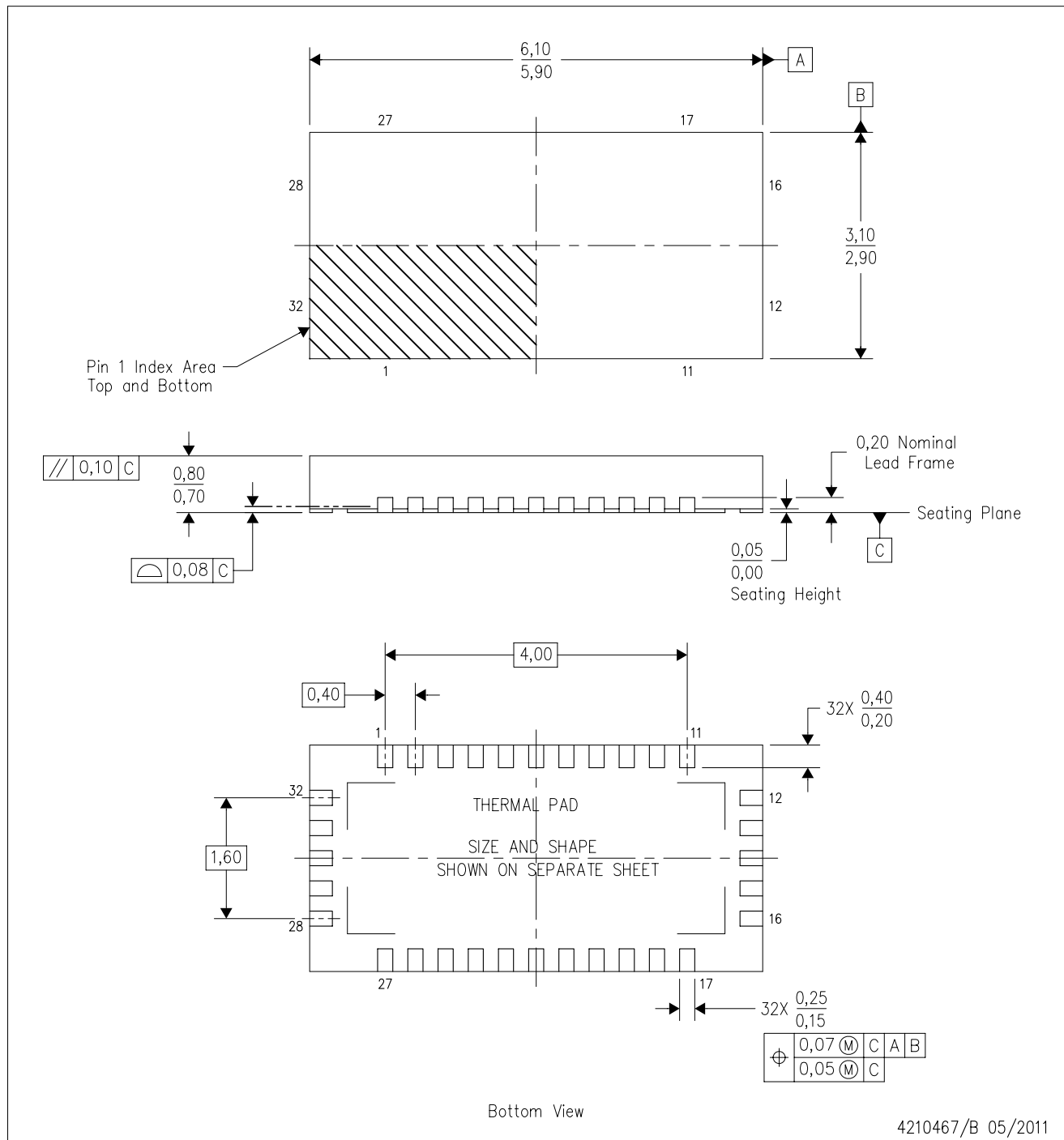
PLASTIC QUAD FLATPACK NO-LEAD



- NOTES:
- All linear dimensions are in millimeters. Dimensioning and tolerancing per ASME Y14.5M-1994.
  - This drawing is subject to change without notice.
  - QFN (Quad Flatpack No-Lead) package configuration.
  - The package thermal pad must be soldered to the board for thermal and mechanical performance.
  - See the additional figure in the Product Data Sheet for details regarding the exposed thermal pad features and dimensions.
  - Reference JEDEC MO-220.

## THERMAL PAD MECHANICAL DATA

RTG (R-PWQFN-N32)

PLASTIC QUAD FLATPACK NO-LEAD

### THERMAL INFORMATION

This package incorporates an exposed thermal pad that is designed to be attached directly to an external heatsink. The thermal pad must be soldered directly to the printed circuit board (PCB). After soldering, the PCB can be used as a heatsink. In addition, through the use of thermal vias, the thermal pad can be attached directly to the appropriate copper plane shown in the electrical schematic for the device, or alternatively, can be attached to a special heatsink structure designed into the PCB. This design optimizes the heat transfer from the integrated circuit (IC).

For information on the Quad Flatpack No-Lead (QFN) package and its advantages, refer to Application Report, QFN/SON PCB Attachment, Texas Instruments Literature No. SLUA271. This document is available at [www.ti.com](http://www.ti.com).

The exposed thermal pad dimensions for this package are shown in the following illustration.

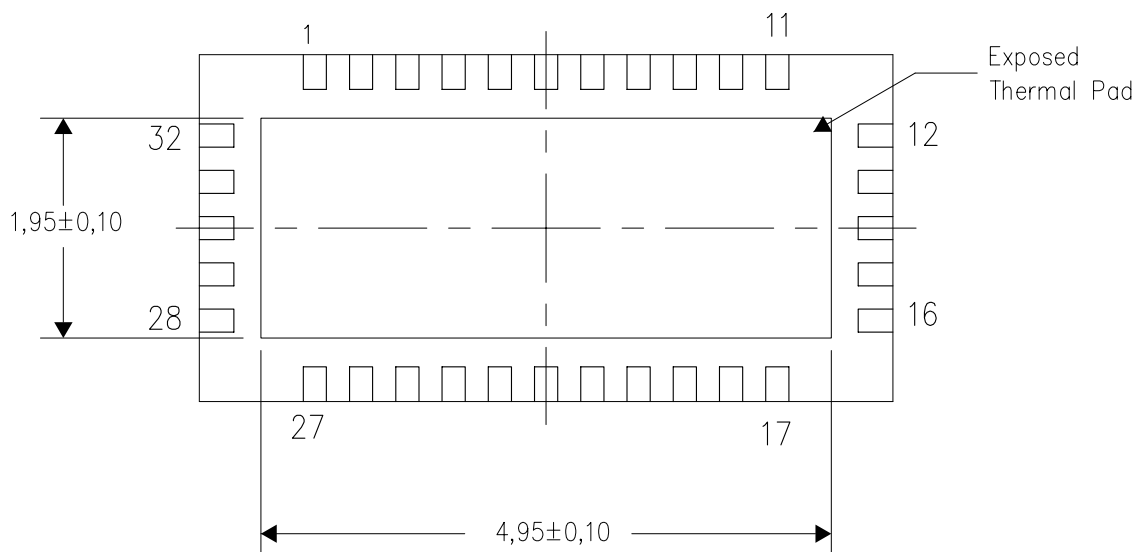

Bottom View

Exposed Thermal Pad Dimensions

4210534/C 05/11

NOTE: All linear dimensions are in millimeters

RTG (R-PWQFN-N32)

PLASTIC QUAD FLATPACK NO-LEAD

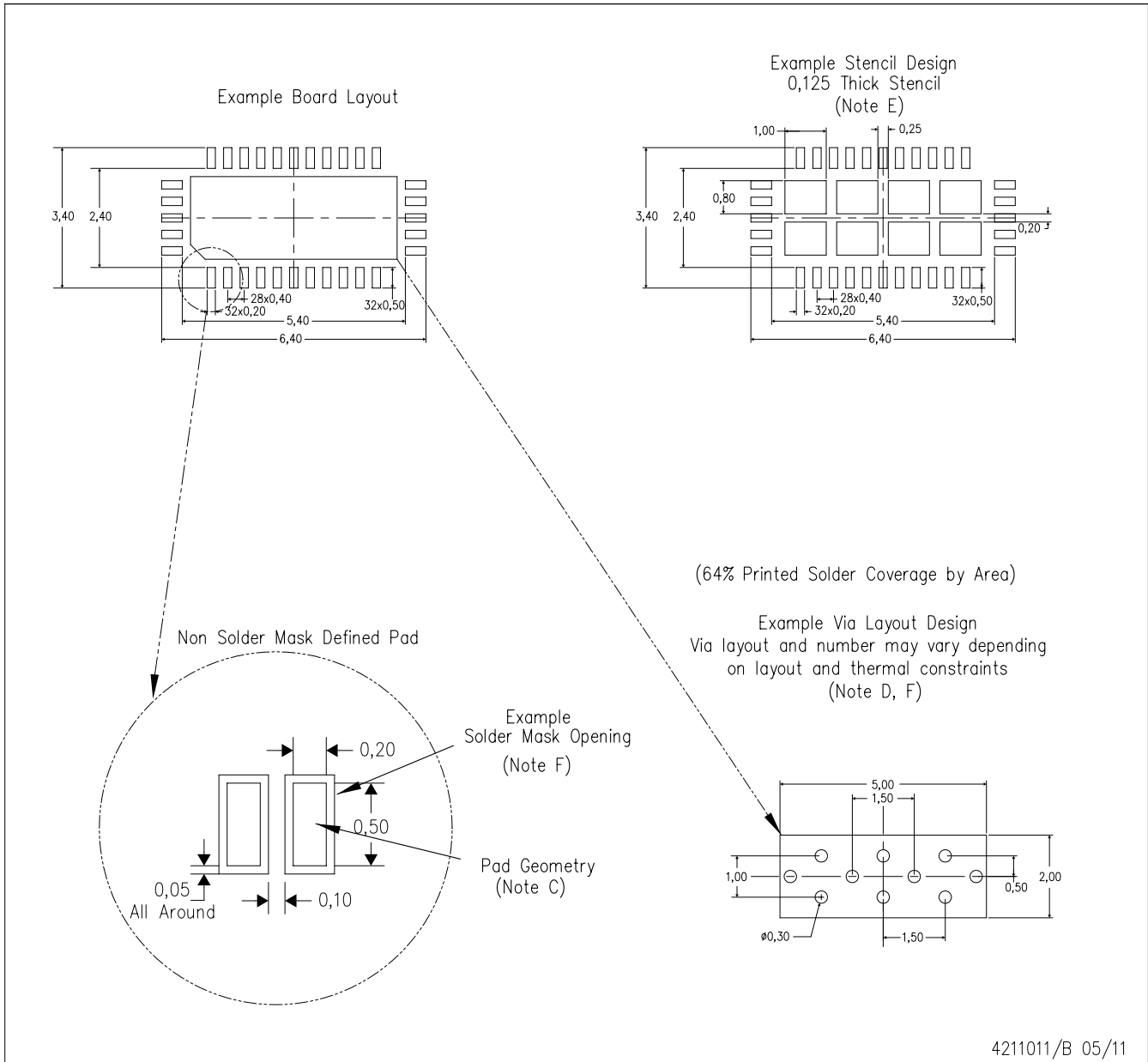

- NOTES:
- A. All linear dimensions are in millimeters.
  - B. This drawing is subject to change without notice.
  - C. Publication IPC-7351 is recommended for alternate designs.
  - D. This package is designed to be soldered to a thermal pad on the board. Refer to Application Note, Quad Flat-Pack Packages, Texas Instruments Literature No. SCBA017, SLUA271, and also the Product Data Sheets for specific thermal information, via requirements, and recommended board layout. These documents are available at [www.ti.com](http://www.ti.com) <<http://www.ti.com>>.
  - E. Laser cutting apertures with trapezoidal walls and also rounding corners will offer better paste release. Customers should contact their board assembly site for stencil design recommendations. Refer to IPC 7525 for stencil design considerations.
  - F. Customers should contact their board fabrication site for recommended solder mask tolerances and via tenting recommendations for vias placed in the thermal pad.

## IMPORTANT NOTICE

Texas Instruments Incorporated and its subsidiaries (TI) reserve the right to make corrections, enhancements, improvements and other changes to its semiconductor products and services per JESD46C and to discontinue any product or service per JESD48B. Buyers should obtain the latest relevant information before placing orders and should verify that such information is current and complete. All semiconductor products (also referred to herein as "components") are sold subject to TI's terms and conditions of sale supplied at the time of order acknowledgment.

TI warrants performance of its components to the specifications applicable at the time of sale, in accordance with the warranty in TI's terms and conditions of sale of semiconductor products. Testing and other quality control techniques are used to the extent TI deems necessary to support this warranty. Except where mandated by applicable law, testing of all parameters of each component is not necessarily performed.

TI assumes no liability for applications assistance or the design of Buyers' products. Buyers are responsible for their products and applications using TI components. To minimize the risks associated with Buyers' products and applications, Buyers should provide adequate design and operating safeguards.

TI does not warrant or represent that any license, either express or implied, is granted under any patent right, copyright, mask work right, or other intellectual property right relating to any combination, machine, or process in which TI components or services are used. Information published by TI regarding third-party products or services does not constitute a license to use such products or services or a warranty or endorsement thereof. Use of such information may require a license from a third party under the patents or other intellectual property of the third party, or a license from TI under the patents or other intellectual property of TI.

Reproduction of significant portions of TI information in TI data books or data sheets is permissible only if reproduction is without alteration and is accompanied by all associated warranties, conditions, limitations, and notices. TI is not responsible or liable for such altered documentation. Information of third parties may be subject to additional restrictions.

Resale of TI components or services with statements different from or beyond the parameters stated by TI for that component or service voids all express and any implied warranties for the associated TI component or service and is an unfair and deceptive business practice. TI is not responsible or liable for any such statements.

Buyer acknowledges and agrees that it is solely responsible for compliance with all legal, regulatory and safety-related requirements concerning its products, and any use of TI components in its applications, notwithstanding any applications-related information or support that may be provided by TI. Buyer represents and agrees that it has all the necessary expertise to create and implement safeguards which anticipate dangerous consequences of failures, monitor failures and their consequences, lessen the likelihood of failures that might cause harm and take appropriate remedial actions. Buyer will fully indemnify TI and its representatives against any damages arising out of the use of any TI components in safety-critical applications.

In some cases, TI components may be promoted specifically to facilitate safety-related applications. With such components, TI's goal is to help enable customers to design and create their own end-product solutions that meet applicable functional safety standards and requirements. Nonetheless, such components are subject to these terms.

No TI components are authorized for use in FDA Class III (or similar life-critical medical equipment) unless authorized officers of the parties have executed a special agreement specifically governing such use.

Only those TI components which TI has specifically designated as military grade or "enhanced plastic" are designed and intended for use in military/aerospace applications or environments. Buyer acknowledges and agrees that any military or aerospace use of TI components which have **not** been so designated is solely at the Buyer's risk, and that Buyer is solely responsible for compliance with all legal and regulatory requirements in connection with such use.

TI has specifically designated certain components which meet ISO/TS16949 requirements, mainly for automotive use. Components which have not been so designated are neither designed nor intended for automotive use; and TI will not be responsible for any failure of such components to meet such requirements.

### Products

Audio	<a href="http://www.ti.com/audio">www.ti.com/audio</a>
Amplifiers	<a href="http://amplifier.ti.com">amplifier.ti.com</a>
Data Converters	<a href="http://dataconverter.ti.com">dataconverter.ti.com</a>
DLP® Products	<a href="http://www.dlp.com">www.dlp.com</a>
DSP	<a href="http://dsp.ti.com">dsp.ti.com</a>
Clocks and Timers	<a href="http://www.ti.com/clocks">www.ti.com/clocks</a>
Interface	<a href="http://interface.ti.com">interface.ti.com</a>
Logic	<a href="http://logic.ti.com">logic.ti.com</a>
Power Mgmt	<a href="http://power.ti.com">power.ti.com</a>
Microcontrollers	<a href="http://microcontroller.ti.com">microcontroller.ti.com</a>
RFID	<a href="http://www.ti-rfid.com">www.ti-rfid.com</a>
OMAP Mobile Processors	<a href="http://www.ti.com/omap">www.ti.com/omap</a>
Wireless Connectivity	<a href="http://www.ti.com/wirelessconnectivity">www.ti.com/wirelessconnectivity</a>

### Applications

Automotive and Transportation	<a href="http://www.ti.com/automotive">www.ti.com/automotive</a>
Communications and Telecom	<a href="http://www.ti.com/communications">www.ti.com/communications</a>
Computers and Peripherals	<a href="http://www.ti.com/computers">www.ti.com/computers</a>
Consumer Electronics	<a href="http://www.ti.com/consumer-apps">www.ti.com/consumer-apps</a>
Energy and Lighting	<a href="http://www.ti.com/energy">www.ti.com/energy</a>
Industrial	<a href="http://www.ti.com/industrial">www.ti.com/industrial</a>
Medical	<a href="http://www.ti.com/medical">www.ti.com/medical</a>
Security	<a href="http://www.ti.com/security">www.ti.com/security</a>
Space, Avionics and Defense	<a href="http://www.ti.com/space-avionics-defense">www.ti.com/space-avionics-defense</a>
Video and Imaging	<a href="http://www.ti.com/video">www.ti.com/video</a>

**TI E2E Community** [e2e.ti.com](http://e2e.ti.com)