

## 4.5-V to 42-V Input, 5-A Step-Down DC-DC Converter With Soft-Start and Eco-mode™

Check for Samples: [TPS54541](#)

### FEATURES

- High Efficiency at Light Loads with Pulse Skipping Eco-mode™
- 87-mΩ High-Side MOSFET
- 152-μA Operating Quiescent Current and 2-μA Shutdown Current
- 100-kHz to 2.5-MHz Adjustable Switching Frequency
- Synchronizes to External Clock
- Low Dropout at Light Loads with Integrated BOOT Recharge FET
- Adjustable UVLO Voltage and Hysteresis
- UV and OV Power-Good Output
- Adjustable Soft-Start and Sequencing
- 0.8-V 1% Internal Voltage Reference
- 10-Pin SON with Thermal Pad Package
- -40°C to 150°C T<sub>J</sub> Operating Range
- Supported by WEBENCH® Software Tool

### APPLICATIONS

- Industrial Automation and Motor Control
- Vehicle Accessories: GPS (see [SLVA412](#)), Entertainment
- USB-Dedicated Charging Ports and Battery Chargers (see [SLVA464](#))
- 12-V and 24-V Industrial, Automotive and Communications Power Systems

### DESCRIPTION

The TPS54541 device is a 42-V 5-A step-down regulator with an integrated high-side MOSFET. The device survives load dump pulses up to 45 V per ISO 7637. Current mode control provides simple external compensation and flexible component selection. A low-ripple pulse-skip mode reduces the no load supply current to 152 μA. Shutdown supply current is reduced to 2 μA when the enable pin is pulled low.

Undervoltage lockout is internally set at 4.3 V but can increase using an external resistor divider at the enable pin. The output voltage startup ramp is controlled by the soft-start pin that can also be configured for sequencing and tracking. An open-drain power-good signal indicates the output is within 93% to 106% of the nominal voltage.

A wide adjustable switching-frequency range allows for optimization of either efficiency or external component size. Cycle-by-cycle current limit, frequency foldback and thermal shutdown protects internal and external components during an overload condition.

The TPS54541 device is available in a 10-pin 4-mm x 4-mm SON package.

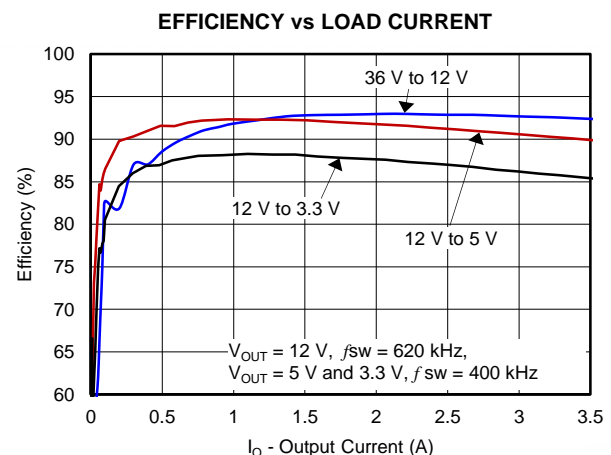
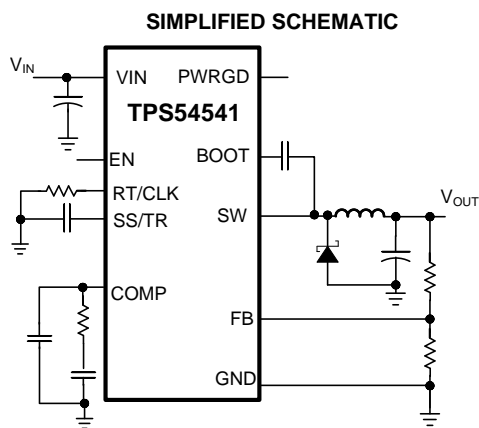

Please be aware that an important notice concerning availability, standard warranty, and use in critical applications of Texas Instruments semiconductor products and disclaimers thereto appears at the end of this data sheet.

Eco-mode is a trademark of Texas Instruments.

WEBENCH is a registered trademark of Texas Instruments.



This integrated circuit can be damaged by ESD. Texas Instruments recommends that all integrated circuits be handled with appropriate precautions. Failure to observe proper handling and installation procedures can cause damage.

ESD damage can range from subtle performance degradation to complete device failure. Precision integrated circuits may be more susceptible to damage because very small parametric changes could cause the device not to meet its published specifications.

## DEVICE INFORMATION

### PIN CONFIGURATION

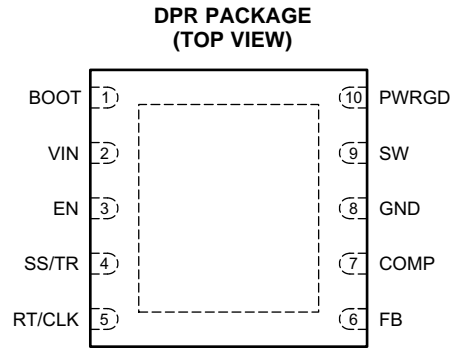

### PIN FUNCTIONS

PIN		I/O	DESCRIPTION
NAME	NO.		
BOOT	1	O	A bootstrap capacitor is required between BOOT and SW. If the voltage on this capacitor is below the minimum required to operate the high-side MOSFET, the gate drive is switched off until the capacitor is refreshed.
COMP	7	O	Error amplifier output and input to the output switch current (PWM) comparator. Connect frequency compensation components to this pin.
EN	3	I	Enable pin, with an internal pullup current source. Pull below 1.2 V to disable. Float to enable. Adjust the input undervoltage lockout with two resistors. See the <a href="#">Enable and Adjusting Undervoltage Lockout</a> section.
FB	6	I	Inverting input of the transconductance (gm) error amplifier.
GND	8	–	Ground
PWRGD	10	O	Power Good is an open drain output that asserts low if the output voltage is out of regulation due to thermal shutdown, dropout, over-voltage or EN shut down.
RT/CLK	5	I	Resistor Timing and External Clock. An internal amplifier holds this pin at a fixed voltage when using an external resistor to ground to set the switching frequency. If the pin is pulled above the PLL upper threshold, a mode change occurs and the pin becomes a synchronization input. The internal amplifier is disabled and the pin is a high impedance clock input to the internal PLL. If clocking edges stop, the internal amplifier is re-enabled and the operating mode returns to resistor frequency programming.
SS/TR	4	I	Soft-start and Tracking. An external capacitor connected to this pin sets the output rise time. Because the voltage on this pin overrides the internal reference, SS/TR can be used for tracking and sequencing.
SW	9	I	The source of the internal high-side power MOSFET and switching node of the converter.
VIN	2	I	Input supply voltage with 4.5-V to 42-V operating range.
Thermal Pad	11	–	The GND pin must be electrically connected to the exposed pad on the printed circuit board for proper operation.

FUNCTIONAL BLOCK DIAGRAM

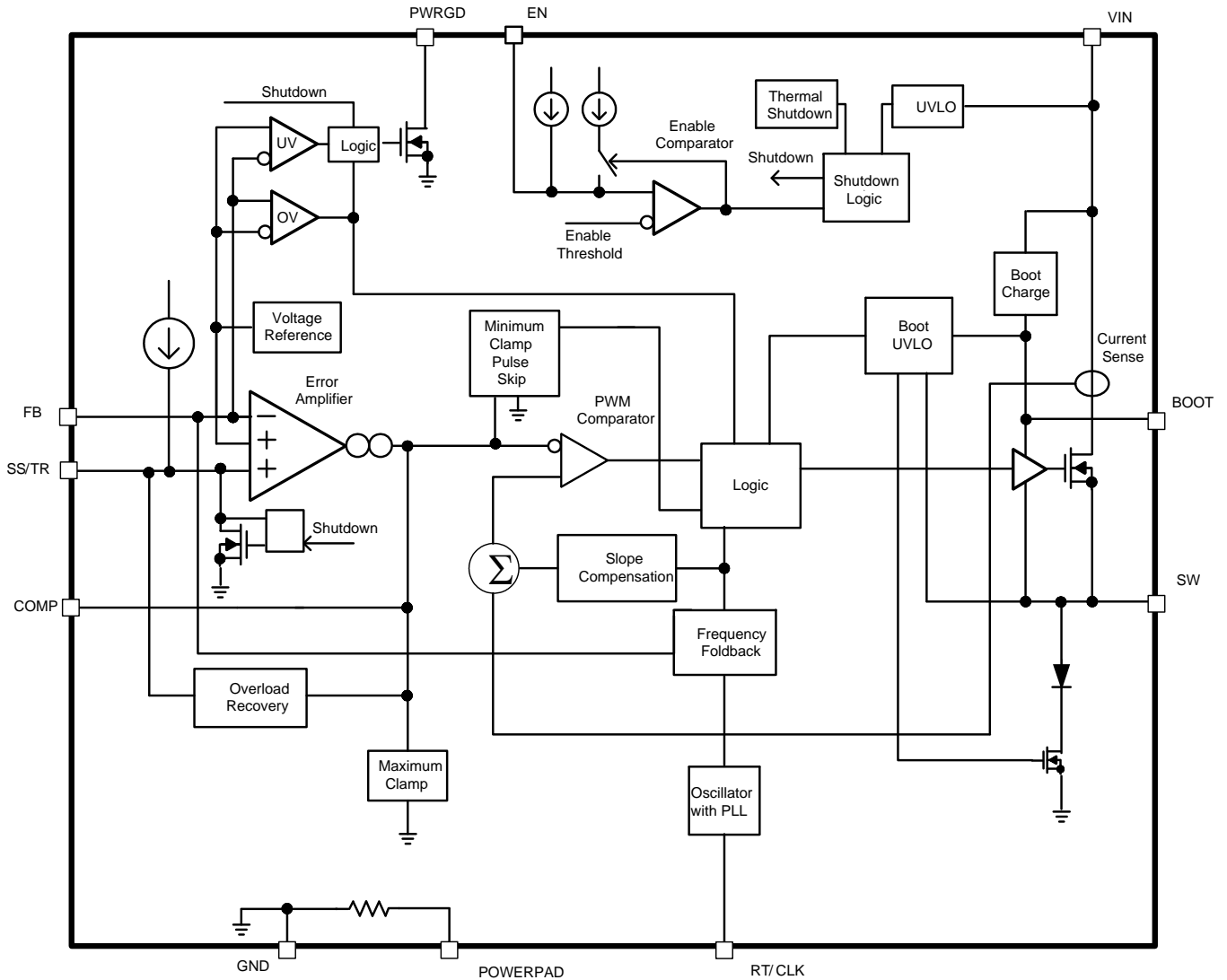

**ABSOLUTE MAXIMUM RATINGS<sup>(1)</sup>**

over operating free-air temperature range (unless otherwise noted)

		VALUE		UNIT
		MIN	MAX	
Input voltage	VIN	-0.3	45	V
	EN	-0.3	8.4	
	BOOT		53	
	FB	-0.3	3	
	COMP	-0.3	3	
	PWRGD	-0.3	6	
	SS/TR	-0.3	3	
	RT/CLK	-0.3	3.6	
Output voltage	BOOT-SW		8	V
	SW	-0.6	45	
	SW, 10-ns Transient	-2	45	
Electrostatic Discharge (HBM) QSS 009-105 (JESD22-A114A)			2	kV
Electrostatic Discharge (CDM) QSS 009-147 (JESD22-C101B.01)			500	V
Operating junction temperature		-40	150	°C
Storage temperature		-65	150	°C

- (1) Stresses beyond those listed under *absolute maximum ratings* may cause permanent damage to the device. These are stress ratings only and functional operation of the device at these or any other conditions beyond those indicated under *recommended operating conditions* is not implied. Exposure to absolute-maximum-rated conditions for extended periods may affect device reliability.

**THERMAL INFORMATION**

THERMAL METRIC <sup>(1)(2)</sup>		TPS54541	UNITS
		DPR (10 PINS)	
$\theta_{JA}$	Junction-to-ambient thermal resistance (standard board)	35.1	°C/W
$\psi_{JT}$	Junction-to-top characterization parameter	0.3	
$\psi_{JB}$	Junction-to-board characterization parameter	12.5	
$\theta_{JcTop}$	Junction-to-case(top) thermal resistance	34.1	
$\theta_{JcBot}$	Junction-to-case(bottom) thermal resistance	2.2	
$\theta_{JB}$	Junction-to-board thermal resistance	12.3	

- (1) For more information about traditional and new thermal metrics, see the IC Package Thermal Metrics application report, [SPRA953](#).  
(2) Power rating at a specific ambient temperature  $T_A$  should be determined with a junction temperature of 150°C. This is the point where distortion starts to substantially increase. See power dissipation estimate in application section of this data sheet for more information.

## ELECTRICAL CHARACTERISTICS

 $T_J = -40^{\circ}\text{C}$  to  $150^{\circ}\text{C}$ ,  $V_{IN} = 4.5\text{ V}$  to  $42\text{ V}$  (unless otherwise noted)

PARAMETER	TEST CONDITIONS	MIN	TYP	MAX	UNIT
<b>SUPPLY VOLTAGE (VIN PIN)</b>					
Operating input voltage		4.5		42	V
Internal undervoltage lockout threshold	Rising	4.1	4.3	4.48	V
Internal undervoltage lockout threshold hysteresis			325		mV
Shutdown supply current	$EN = 0\text{ V}$ , $25^{\circ}\text{C}$ , $4.5\text{ V} \leq V_{IN} \leq 42\text{ V}$		2.25	4.5	$\mu\text{A}$
Operating: nonswitching supply current	$FB = 0.9\text{ V}$ , $T_A = 25^{\circ}\text{C}$		152	200	
<b>ENABLE AND UVLO (EN PIN)</b>					
Enable threshold voltage	No voltage hysteresis, rising and falling	1.1	1.2	1.3	V
Input current	Enable threshold +50 mV		-4.6		$\mu\text{A}$
	Enable threshold -50 mV	-0.58	-1.2	-1.8	
Hysteresis current		-2.2	-3.4	-4.5	$\mu\text{A}$
Enable to COMP active	$V_{IN} = 12\text{ V}$ , $T_A = 25^{\circ}\text{C}$		540		$\mu\text{s}$
<b>VOLTAGE REFERENCE</b>					
Voltage reference		0.792	0.8	0.808	V
<b>HIGH-SIDE MOSFET</b>					
On-resistance	$V_{IN} = 12\text{ V}$ , $BOOT-SW = 6\text{ V}$		87	185	$\text{m}\Omega$
<b>ERROR AMPLIFIER</b>					
Input current			50		nA
Error amplifier transconductance (gm)	$-2\text{ }\mu\text{A} < I_{COMP} < 2\text{ }\mu\text{A}$ , $V_{COMP} = 1\text{ V}$		350		$\mu\text{Mhos}$
Error amplifier transconductance (gm) during soft-start	$-2\text{ }\mu\text{A} < I_{COMP} < 2\text{ }\mu\text{A}$ , $V_{COMP} = 1\text{ V}$ , $V_{FB} = 0.4\text{ V}$		77		$\mu\text{Mhos}$
Error amplifier dc gain	$V_{FB} = 0.8\text{ V}$		10,000		V/V
Min unity gain bandwidth			2500		kHz
Error amplifier source/sink	$V_{(COMP)} = 1\text{ V}$ , 100 mV overdrive		$\pm 30$		$\mu\text{A}$
COMP to SW current transconductance			17		A/V
<b>CURRENT LIMIT</b>					
Current limit threshold	All $V_{IN}$ and temperatures, Open Loop <sup>(1)</sup>	6.3	7.5	8.8	A
	All temperatures, $V_{IN} = 12\text{ V}$ , Open Loop <sup>(1)</sup>	6.3	7.5	8.3	
	$V_{IN} = 12\text{ V}$ , $T_A = 25^{\circ}\text{C}$ , Open Loop <sup>(1)</sup>	7.1	7.5	7.9	
Current limit threshold delay			60		ns
<b>THERMAL SHUTDOWN</b>					
Thermal shutdown			176		$^{\circ}\text{C}$
Thermal shutdown hysteresis			12		$^{\circ}\text{C}$
<b>TIMING RESISTOR AND EXTERNAL CLOCK (RT/CLK PIN)</b>					
Switching frequency range using RT mode		100		2500	kHz
$f_{SW}$ Switching frequency	$R_T = 200\text{ k}\Omega$	450	500	550	kHz
Switching frequency range using CLK mode		160		2300	kHz
Minimum CLK input pulse width			15		ns
RT/CLK high threshold			1.55	2	V
RT/CLK low threshold		0.5	1.2		V
RT/CLK falling edge to SW rising edge delay	Measured at 500 kHz with RT resistor in series		55		ns
PLL lock in time	Measured at 500 kHz		78		$\mu\text{s}$
<b>SOFT START AND TRACKING (SS/TR PIN)</b>					
Charge current	$V_{SS/TR} = 0.4\text{ V}$		1.7		$\mu\text{A}$

(1) Open Loop current limit measured directly at the SW pin and is independent of the inductor value and slope compensation.

**ELECTRICAL CHARACTERISTICS (continued)**
 $T_J = -40^{\circ}\text{C}$  to  $150^{\circ}\text{C}$ ,  $V_{IN} = 4.5\text{ V}$  to  $42\text{ V}$  (unless otherwise noted)

PARAMETER	TEST CONDITIONS	MIN	TYP	MAX	UNIT
SS/TR-to-FB matching	$V_{SS/TR} = 0.4\text{ V}$		42		mV
SS/TR-to-reference crossover	98% nominal		1.16		V
SS/TR discharge current (overload)	$FB = 0\text{ V}$ , $V_{SS/TR} = 0.4\text{ V}$		354		$\mu\text{A}$
SS/TR discharge voltage	$FB = 0\text{ V}$		54		mV
<b>POWER GOOD (PWRGD PIN)</b>					
FB threshold for PWRGD low	FB falling		90		%
FB threshold for PWRGD high	FB rising		93		%
FB threshold for PWRGD low	FB rising		108		%
FB threshold for PWRGD high	FB falling		106		%
Hysteresis	FB falling		2.5		%
Output high leakage	$V_{PWRGD} = 5.5\text{ V}$ , $T_A = 25^{\circ}\text{C}$		10		nA
On resistance	$I_{PWRGD} = 3\text{ mA}$ , $V_{FB} < 0.79\text{ V}$		45		$\Omega$
Minimum $V_{IN}$ for defined output	$V_{PWRGD} < 0.5\text{ V}$ , $I_{PWRGD} = 100\ \mu\text{A}$		0.9	2	V

TYPICAL CHARACTERISTICS

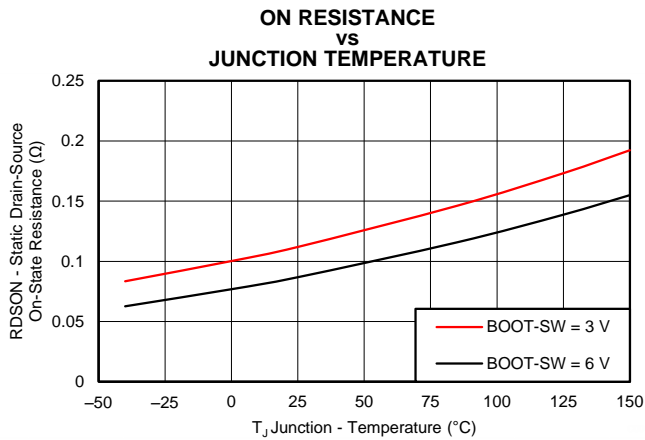

Figure 1.

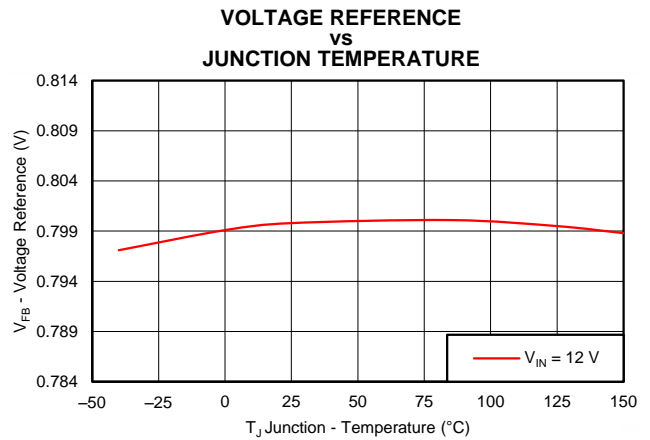

Figure 2.

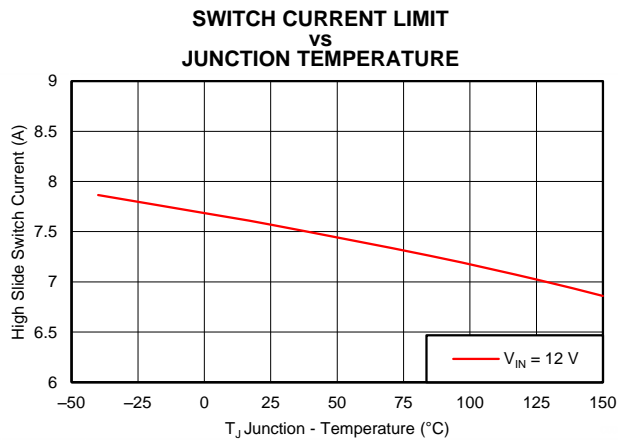

Figure 3.

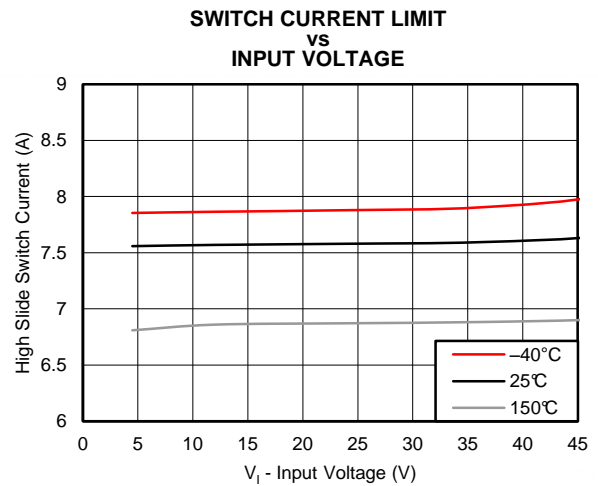

Figure 4.

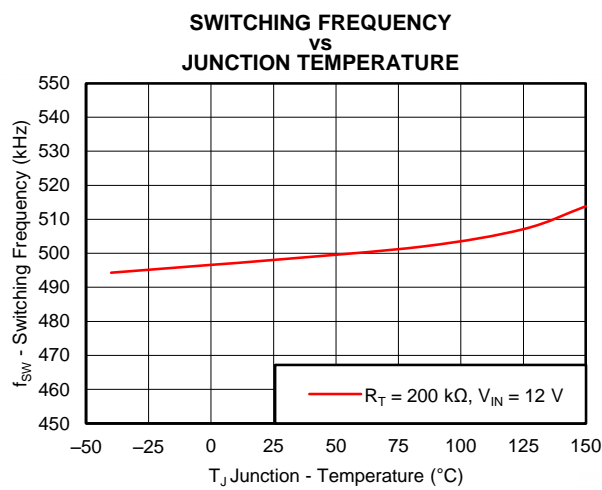

Figure 5.

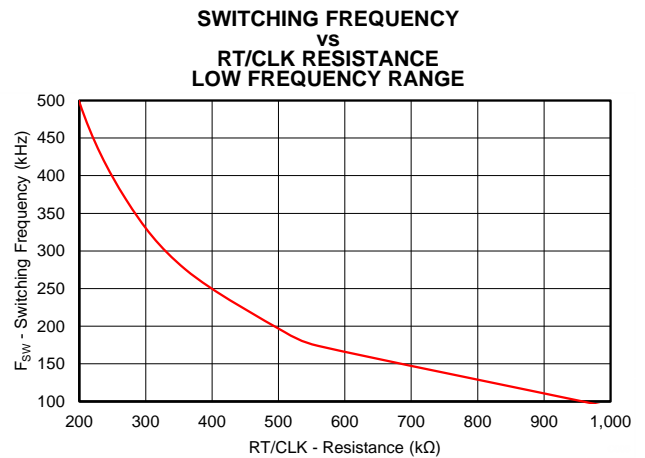

Figure 6.

TYPICAL CHARACTERISTICS (continued)

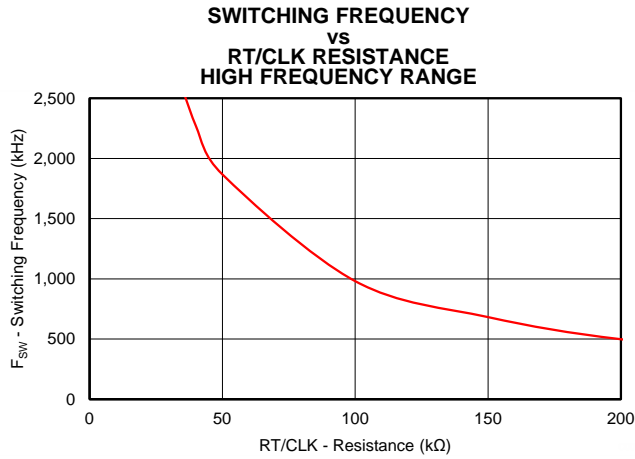

Figure 7.

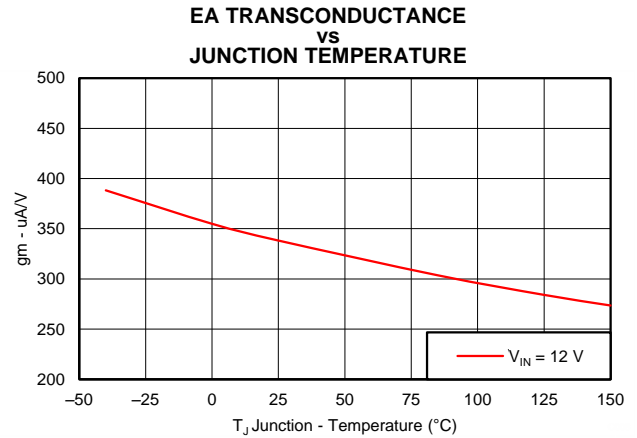

Figure 8.

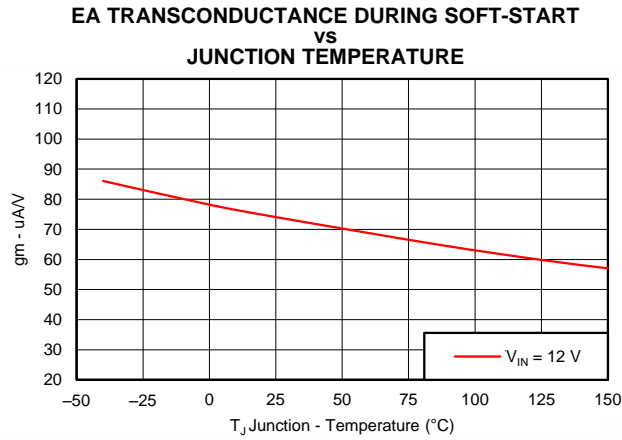

Figure 9.

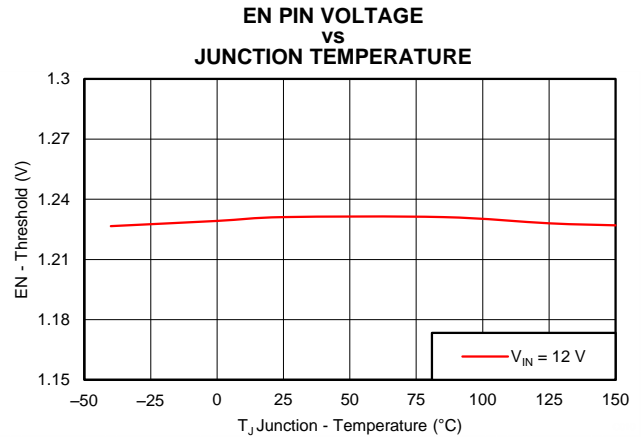

Figure 10.

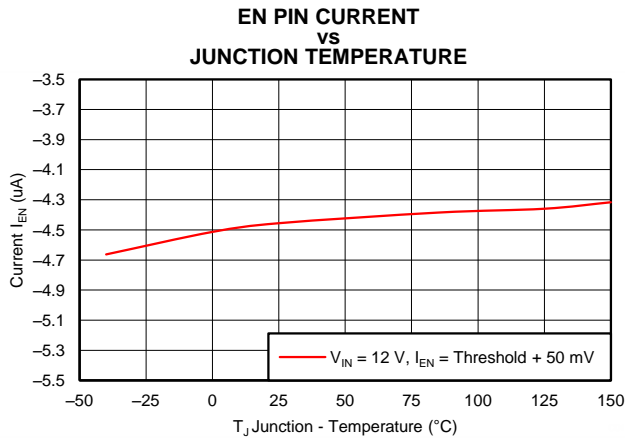

Figure 11.

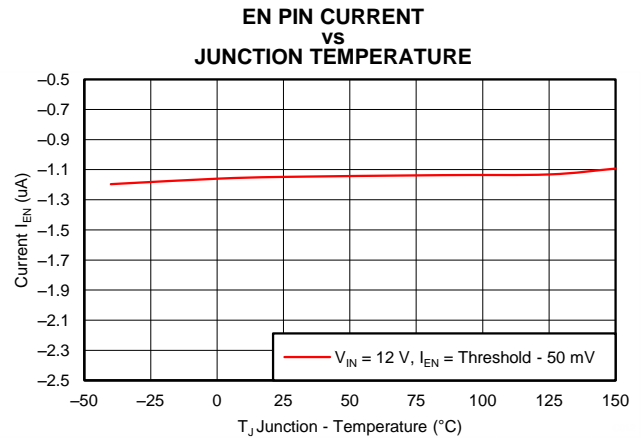

Figure 12.



TYPICAL CHARACTERISTICS (continued)

EN PIN CURRENT HYSTERESIS  
VS  
JUNCTION TEMPERATURE

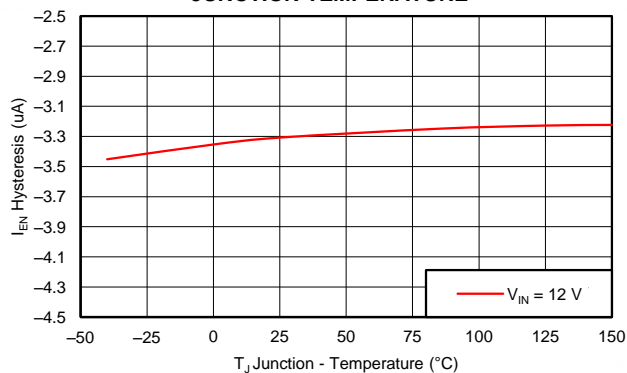

Figure 13.

SWITCHING FREQUENCY  
VS  
FB

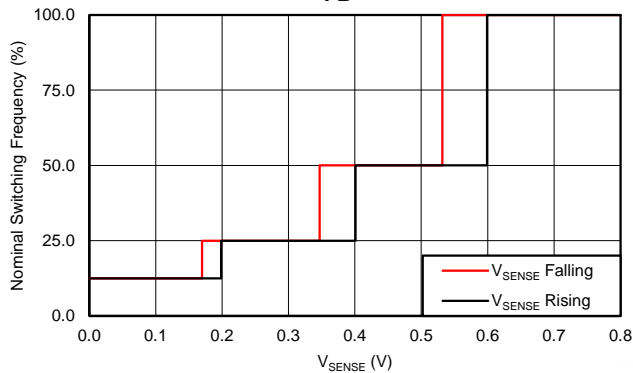

Figure 14.

SHUTDOWN SUPPLY CURRENT  
VS  
JUNCTION TEMPERATURE

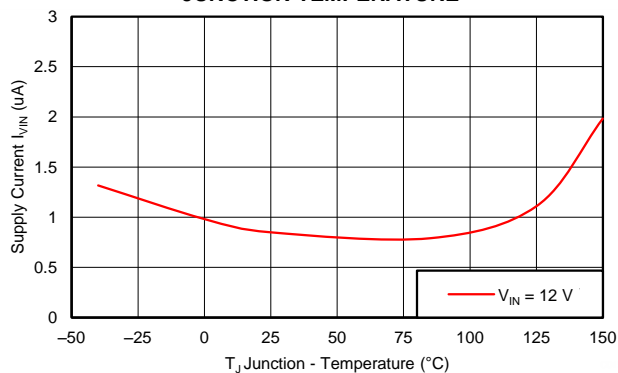

Figure 15.

SHUTDOWN SUPPLY CURRENT  
VS  
INPUT VOLTAGE (V\_IN)

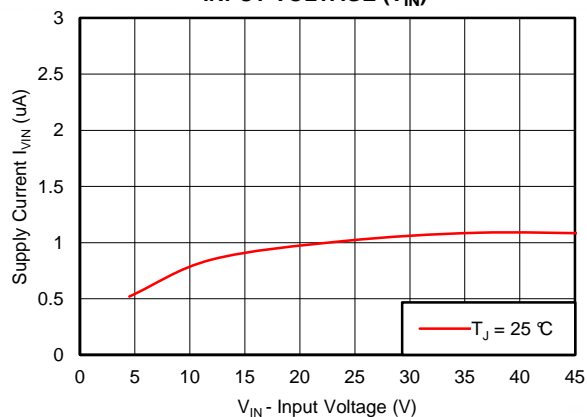

Figure 16.

V\_IN SUPPLY CURRENT  
VS  
JUNCTION TEMPERATURE

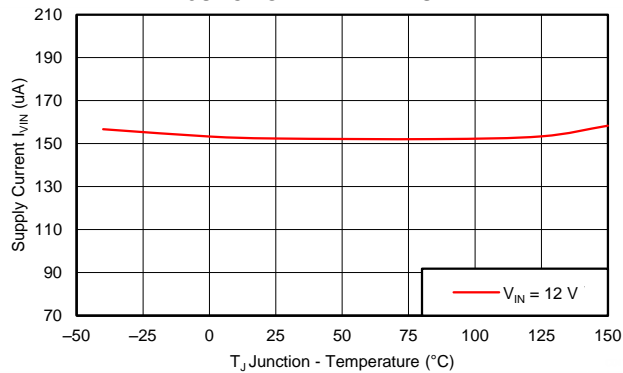

Figure 17.

V\_IN SUPPLY CURRENT  
VS  
INPUT VOLTAGE

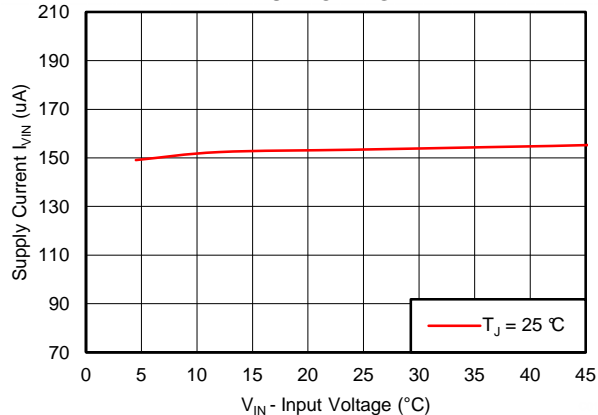

Figure 18.

TYPICAL CHARACTERISTICS (continued)

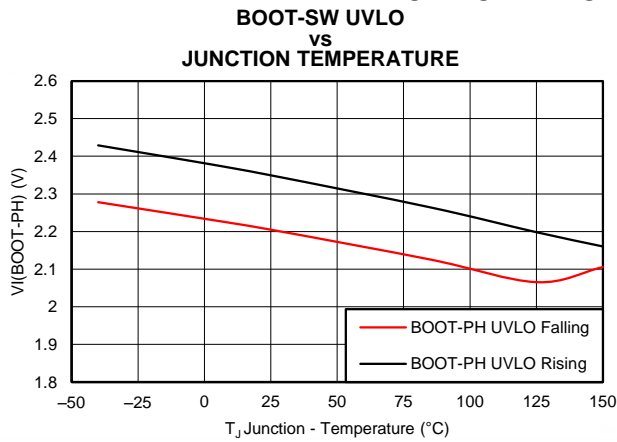

Figure 19.

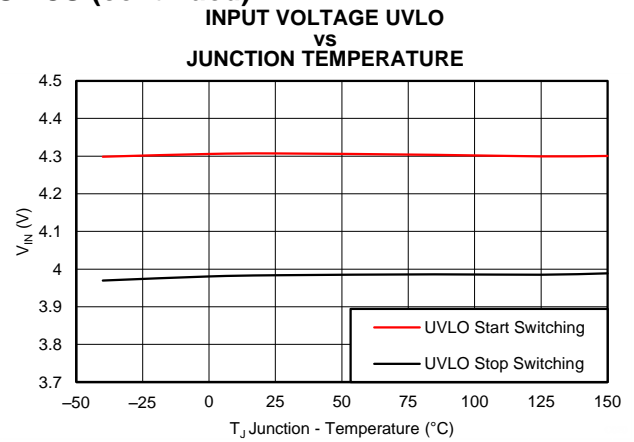

Figure 20.

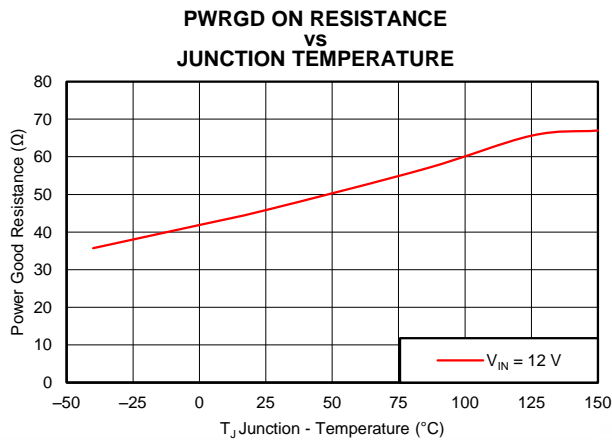

Figure 21.

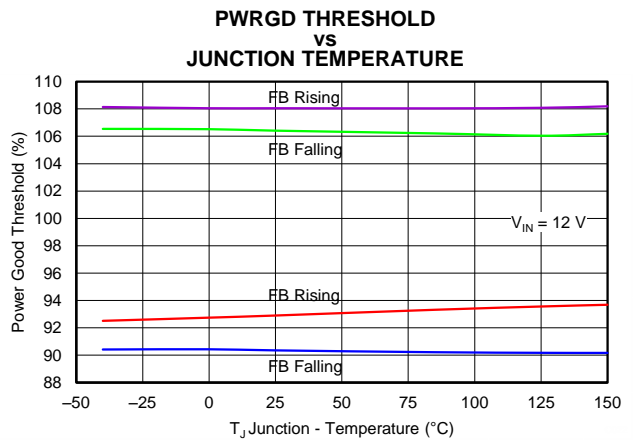

Figure 22.

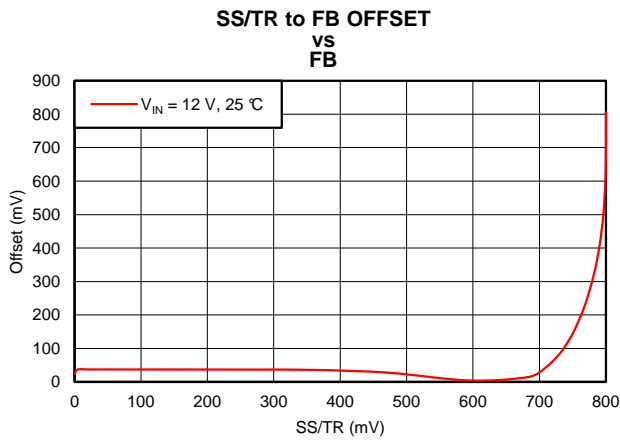

Figure 23.

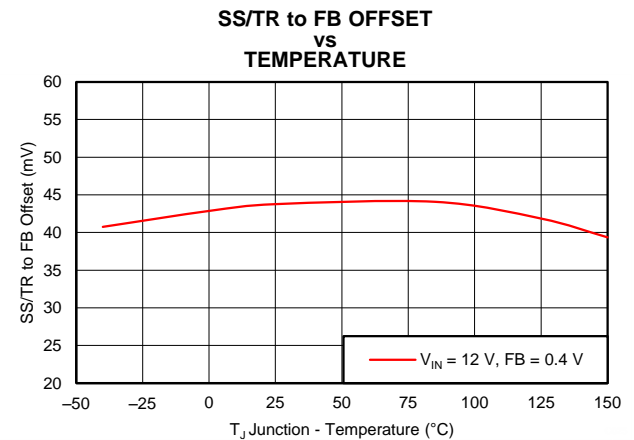
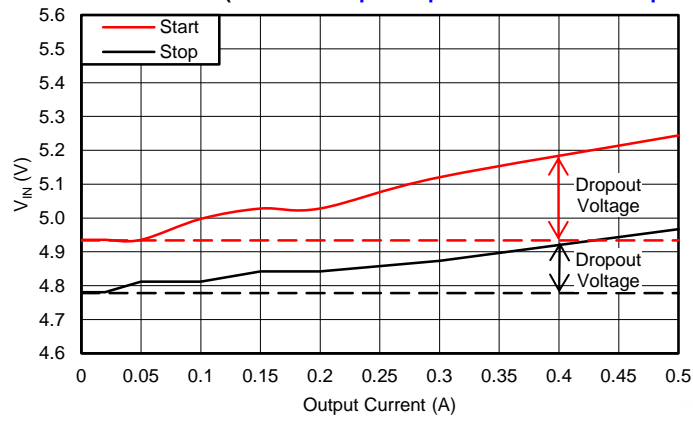

Figure 24.

**TYPICAL CHARACTERISTICS (continued)**  
**5-V START AND STOP VOLTAGE (see [Low Dropout Operation and Bootstrap Voltage \(BOOT\)](#))**



**Figure 25.**

## OVERVIEW

The TPS54541 is a 42-V 5-A, step-down (buck) regulator with an integrated high-side n-channel MOSFET. The device implements constant-frequency current-mode control which reduces output capacitance and simplifies external frequency compensation. The wide switching frequency range of 100 to 2500 kHz allows for either efficiency or size optimization when selecting the output filter components. The switching frequency is adjusted using a resistor to ground connected to the RT/CLK pin. The device has an internal phase-locked loop (PLL) connected to the RT/CLK pin that synchronizes the power switch turn-on to a falling edge of an external clock signal.

The TPS54541 device has a default input start-up voltage of 4.3 V typical. The EN pin adjusts the input-voltage undervoltage-lockout (UVLO) threshold with two external resistors. An internal-pullup current source enables operation when the EN pin is floating. The operating current is 152  $\mu$ A under a no load condition when not switching. When the device is disabled, the supply current is 2  $\mu$ A.

The integrated 87-m $\Omega$  high-side MOSFET supports high-efficiency power-supply designs capable of delivering 5 A of continuous current to a load. The gate-drive bias voltage for the integrated high-side MOSFET is supplied by a bootstrap capacitor connected from the BOOT to SW pins. The TPS54541 device reduces the external component count by integrating the bootstrap recharge diode. The BOOT pin capacitor voltage is monitored by a UVLO circuit which turns off the high-side MOSFET when the BOOT to SW voltage falls below a preset threshold. An automatic BOOT capacitor recharge circuit allows the TPS54541 device to operate at high duty cycles approaching 100%. Therefore, the maximum output voltage is near the minimum input supply voltage of the application. The minimum output voltage is the internal 0.8-V feedback reference.

Output overvoltage transients are minimized by an Overvoltage Protection (OVP) comparator. When the OVP comparator is activated, the high-side MOSFET turns off and remains off until the output voltage is less than 106% of the desired output voltage.

The SS/TR (soft-start/tracking) pin minimizes inrush currents or provides power-supply sequencing during power up. A small value capacitor must be connected to the pin to adjust the soft-start time. A resistor divider can be connected to the pin for critical power supply sequencing requirements. The SS/TR pin is discharged before the output powers up. This discharging ensures a repeatable restart after an overtemperature fault, UVLO fault, or a disabled condition. When the overload condition is removed, the soft-start circuit controls the recovery from the fault output level to the nominal regulation voltage. A frequency-foldback circuit reduces the switching frequency during startup and overcurrent fault conditions to help maintain control of the inductor current.

## DETAILED DESCRIPTION

### Fixed-Frequency PWM Control

The TPS54541 device uses fixed-frequency peak-current-mode control with adjustable switching frequency. The output voltage is compared through external resistors connected to the FB pin to an internal voltage reference by an error amplifier. An internal oscillator initiates the turn-on of the high-side power switch. The error amplifier output at the COMP pin controls the high-side power switch current. When the high-side MOSFET switch current reaches the threshold level set by the COMP voltage, the power switch turns off. The COMP pin voltage increases and decreases as the output current increases and decreases. The device implements current limiting by clamping the COMP pin voltage to a maximum level. The pulse skipping Eco-mode is implemented with a minimum voltage clamp on the COMP pin.

### Slope Compensation Output Current

The TPS54541 device adds a compensating ramp to the MOSFET switch current-sense signal. This slope compensation prevents sub-harmonic oscillations at duty cycles greater than 50%. The peak current limit of the high-side switch is not affected by the slope compensation and remains constant over the full duty-cycle range.

## Pulse Skip Eco-mode

The TPS54541 device operates in a pulse-skipping Eco-mode at light-load currents to improve efficiency by reducing switching and gate drive losses. If the output voltage is within regulation and the peak switch current at the end of any switching cycle is below the pulse-skipping current threshold, the device enters Eco-mode. The pulse-skipping current threshold is the peak switch-current level corresponding to a nominal COMP voltage of 600 mV.

When in Eco-mode, the COMP pin voltage is clamped at 600 mV and the high-side MOSFET is inhibited. Because the device is not switching, the output voltage begins to decay. The voltage-control loop responds to the falling output voltage by increasing the COMP pin voltage. The high-side MOSFET is enabled and switching resumes when the error amplifier lifts COMP above the pulse skipping threshold. The output voltage recovers to the regulated value, and COMP eventually falls below the Eco-mode pulse-skipping threshold at which time the device again enters Eco-mode. The internal PLL remains operational when in Eco-mode. When operating at light load currents in Eco-mode, the switching transitions occur synchronously with the external clock signal.

During Eco-mode operation, the TPS54541 device senses and controls peak switch current, not the average load current. Therefore the load current at which the device enters Eco-mode is dependent on the output inductor value. The circuit in [Figure 46](#) enters Eco-mode at about 25-mA output current. As the load current approaches zero, the device enters a pulse skip mode during which it draws only 152-μA input quiescent current.

## Low Dropout Operation and Bootstrap Voltage (BOOT)

The TPS54541 device provides an integrated bootstrap voltage regulator. A small capacitor between the BOOT and SW pins provides the gate-drive voltage for the high-side MOSFET. The BOOT capacitor refreshes when the high-side MOSFET is off and the external low-side diode conducts. The recommended value of the BOOT capacitor is 0.1 μF. A ceramic capacitor with an X7R or X5R grade dielectric with a voltage rating of 10 V or higher is recommended for stable performance over temperature and voltage.

When operating with a low voltage difference from input to output, the high-side MOSFET of the TPS54541 device operates at 100% duty cycle as long as the BOOT to SW pin voltage is greater than 2.1 V. When the voltage from BOOT to SW drops below 2.1 V, the high-side MOSFET turns off and an integrated low-side MOSFET pulls SW low to recharge the BOOT capacitor. To reduce the losses of the small low-side MOSFET at high output voltages, the low-side MOSFET is disabled at 24 V output and re-enabled when the output reaches 21.5 V.

Because the gate-drive current sourced from the BOOT capacitor is small, the high-side MOSFET remains on for many switching cycles before the MOSFET turns off to refresh the capacitor. Thus the effective duty cycle of the switching regulator can be high, approaching 100%. The effective duty cycle of the converter during dropout is mainly influenced by the voltage drops across the power MOSFET, the inductor resistance, the low-side diode voltage, and the printed circuit-board resistance.

The start and stop voltage for a typical 5-V output application is shown in [Figure 25](#) where the input voltage is plotted versus load current. The start voltage is defined as the input voltage required to regulate the output within 1% of nominal. The stop voltage is defined as the input voltage at which the output drops by 5% or where switching stops.

During high duty-cycle (low dropout) conditions, the inductor current ripple increases when the BOOT capacitor recharges resulting in an increase in output voltage ripple. Increased ripple occurs when the off-time required to recharge the BOOT capacitor is longer than the high-side off-time associated with cycle-by-cycle PWM control.

At heavy loads, the minimum input voltage must increase to ensure a monotonic start-up. Use [Equation 1](#) to calculate the minimum input voltage for this condition.

$$V_{OUT(max)} = D_{(max)} \times (V_{IN(min)} - I_{OUT(max)} \times R_{DS(on)} + V_d) - V_d + I_{OUT(max)} \times R_{dc} \quad (1)$$

where

- $D_{(max)} \geq 0.9$
- $V_d$  = forward drop of the catch diode
- $V_{BOOT} = (1.41 \times V_{IN} - 0.554 - V_d \times f_{SW} - 1.847 \times 10^3 \times IB2SW) / (1.41 + f_{SW})$
- $R_{DS(on)} = 1 / (-0.3 \times VB2SW^2 + 3.577 \times VB2SW - 4.246)$
- $IB2SW = 100 \mu A$

- $V_{B2SW} = V_{BOOT} + V_d$

### Error Amplifier

The TPS54541 voltage-regulation loop is controlled by a transconductance error amplifier. The error amplifier compares the FB pin voltage to the lower of the internal soft-start voltage or the internal 0.8-V voltage reference. The transconductance (gm) of the error amplifier is 350  $\mu\text{A/V}$  during normal operation. During soft-start operation, the transconductance is reduced to 78  $\mu\text{A/V}$  and the error amplifier is referenced to the internal soft-start voltage.

The frequency-compensation components (capacitor, series resistor, and capacitor) connect between the error amplifier output COMP pin and GND pin.

### Adjusting the Output Voltage

The internal voltage reference produces a precise 0.8-V  $\pm 1\%$  voltage reference over the operating temperature and voltage range by scaling the output of a bandgap-reference circuit. A resistor divider from the output node to the FB pin sets the output voltage. Using 1% tolerance or better divider resistors is recommended. Select the low-side resistor  $R_{LS}$  for the desired divider current and use Equation 2 to calculate  $R_{HS}$ . To improve efficiency at light loads consider using larger value resistors. However, if the values are too high, the regulator is more susceptible to noise and voltage errors from the FB input current could become noticeable.

$$R_{HS} = R_{LS} \times \left( \frac{V_{OUT} - 0.8 \text{ V}}{0.8 \text{ V}} \right) \quad (2)$$

### Enable and Adjusting Undervoltage Lockout

The TPS54541 device enables when the VIN pin voltage rises above 4.3 V and the EN pin voltage exceeds the enable threshold of 1.2 V. The TPS54541 device disables when the VIN pin voltage falls below 4 V or when the EN pin voltage is below 1.2 V. The EN pin has an internal pullup current source,  $I_1$ , of 1.2  $\mu\text{A}$  enabling operation of the TPS54541 device when the EN pin floats.

If an application requires a higher UVLO threshold, use the circuit shown in Figure 26 to adjust the input voltage UVLO with two external resistors. When the EN pin voltage exceeds 1.2 V, an additional 3.4  $\mu\text{A}$  of hysteresis current,  $I_{HYS}$ , is sourced out of the EN pin. When the EN pin is pulled below 1.2 V, the 3.4- $\mu\text{A}$   $I_{HYS}$  current is removed. This additional current facilitates adjustable input-voltage UVLO hysteresis. Use Equation 3 to calculate  $R_{UVLO1}$  for the desired UVLO hysteresis voltage. Use Equation 4 to calculate  $R_{UVLO2}$  for the desired VIN start voltage.

In applications designed to start at relatively low input voltages (that is, from 4.5 to 9 V) and withstand high input voltages (for example, 40 V), the EN pin can experience a voltage greater than the absolute maximum voltage of 8.4 V during the high input-voltage condition. To avoid exceeding this voltage when using the EN resistors, the EN pin is clamped internally with a 5.8-V Zener diode capable of sinking up to 150  $\mu\text{A}$ .

$$R_{UVLO1} = \frac{V_{START} - V_{STOP}}{I_{HYS}} \quad (3)$$

$$R_{UVLO2} = \frac{V_{ENA}}{\frac{V_{START} - V_{ENA}}{R_{UVLO1}} + I_1} \quad (4)$$

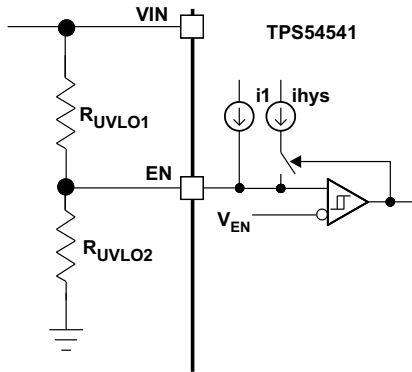

Figure 26. Adjustable Undervoltage Lockout (UVLO)

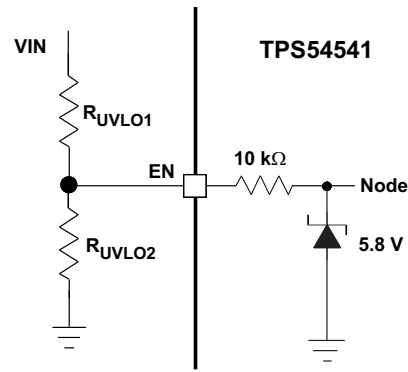

Figure 27. Internal EN Pin Clamp

### Soft-Start/Tracking Pin (SS/TR)

The TPS54541 device effectively uses the lower voltage of the internal voltage reference or the SS/TR pin voltage as the power-supply's reference voltage and regulates the output accordingly. A capacitor on the SS/TR pin to ground implements a soft start time. The TPS54541 device has an internal pullup current source of 1.7  $\mu\text{A}$  that charges the external soft-start capacitor. The calculations for the soft start time (10% to 90%) are shown in Equation 5. The voltage reference ( $V_{\text{REF}}$ ) is 0.8 V and the soft-start current ( $I_{\text{SS}}$ ) is 1.7  $\mu\text{A}$ . The soft-start capacitor should remain lower than 0.47  $\mu\text{F}$  and greater than 0.47 nF.

$$C_{\text{SS}} \text{ (nF)} = \frac{T_{\text{SS}} \text{ (ms)} \times I_{\text{SS}} \text{ (\mu A)}}{V_{\text{REF}} \text{ (V)} \times 0.8} \tag{5}$$

At power up, the TPS54541 device does not begin switching until the soft start pin is discharged to less than 54 mV to ensure a proper power-up, see Figure 28.

Also, during normal operation, the TPS54541 device stops switching, the SS/TR must discharge to 54 mV, and, when the VIN UVLO is exceeded, the EN pin must pull below 1.2 V, otherwise a thermal shutdown event occurs.

The FB voltage follows the SS/TR pin voltage with a 42-mV offset up to 85% of the internal voltage reference. When the SS/TR voltage is greater than 85% on the internal reference voltage the offset increases as the effective system reference transitions from the SS/TR voltage to the internal voltage reference (see Figure 23). The SS/TR voltage ramps linearly until clamped at 2.7 V typically as shown in Figure 28.

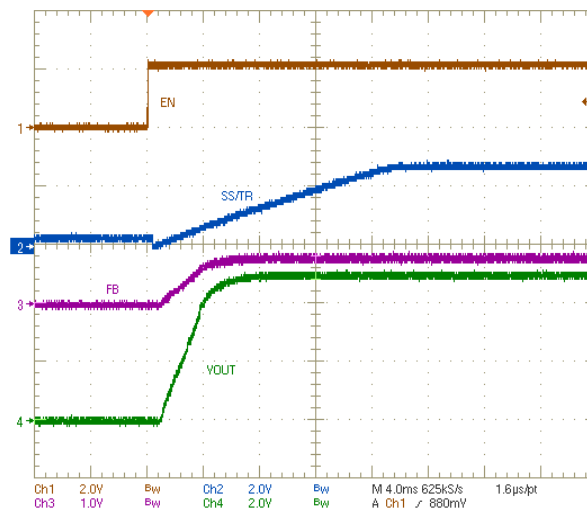

Figure 28. Operation of SS/TR Pin when Starting

### Sequencing

Many of the common power supply sequencing methods are implemented using the SS/TR, EN, and PWRGD pins. The sequential method is implemented using an open-drain output of a power on the reset pin of another device. The sequential method is illustrated in Figure 29 using two TPS54541 devices. The power good is connected to the EN pin on the TPS54541 device which enables the second power supply once the primary supply reaches regulation. If needed, a 1-nF ceramic capacitor on the EN pin of the second power supply provides a 1-ms startup delay. Figure 30 shows the results of Figure 29.

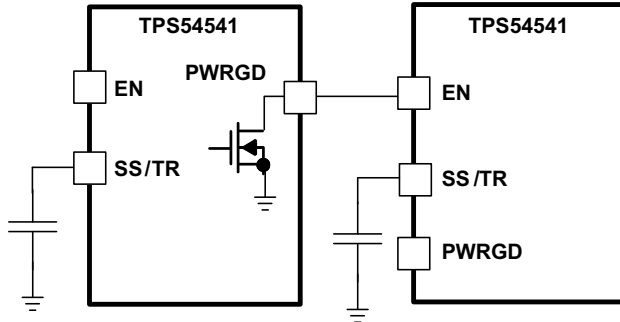

Figure 29. Schematic for Sequential Startup Sequence

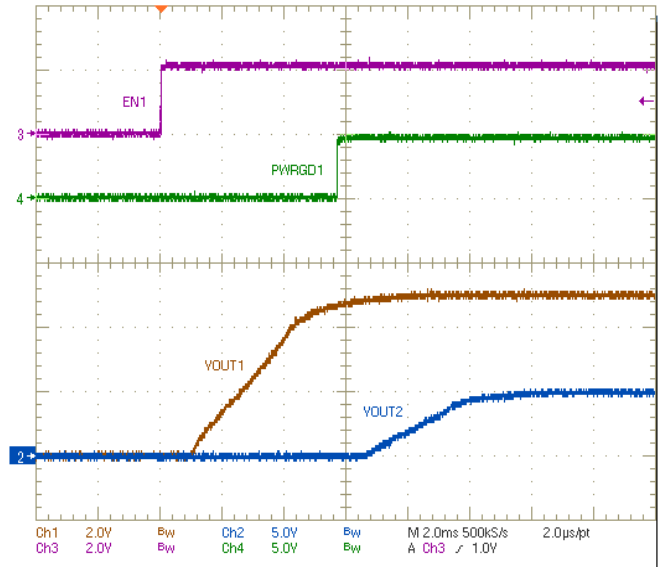

Figure 30. Sequential Startup using EN and PWRGD

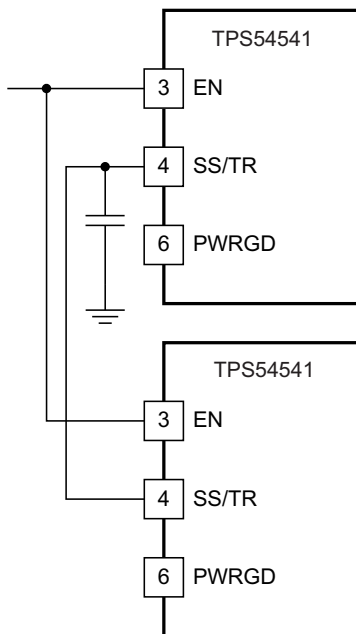

Figure 31. Schematic for Ratiometric Startup Sequence

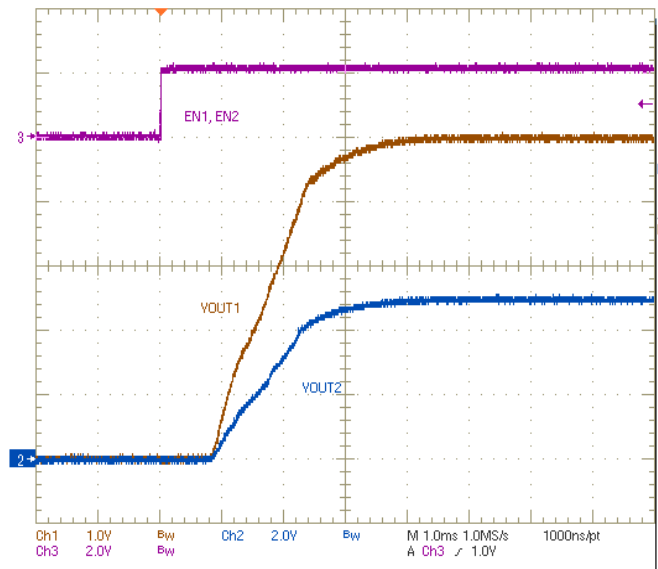
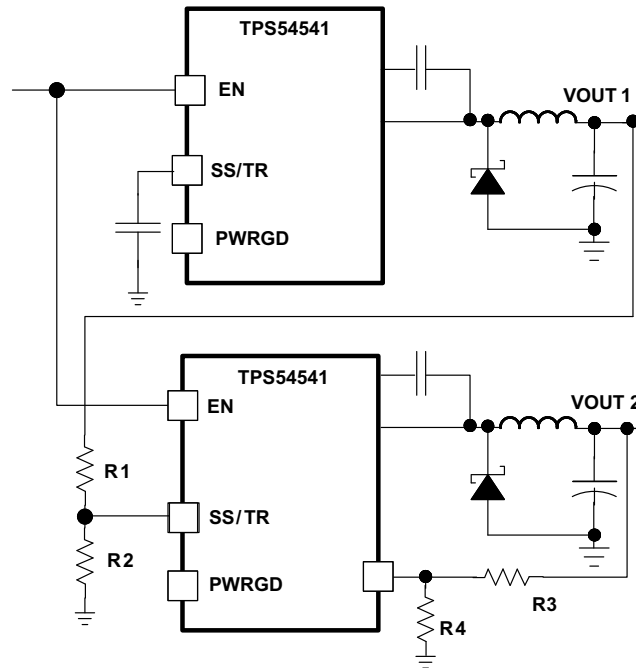

Figure 32. Ratiometric Startup Using Coupled SS/TR pins

Figure 31 shows a method for ratiometric start-up sequence by connecting the SS/TR pins together. The regulator outputs ramp up and reach regulation at the same time. When calculating the soft-start time the pullup current source must be doubled in Equation 5. Figure 32 shows the results of Figure 31.





**Figure 33. Schematic for Ratiometric and Simultaneous Startup Sequence**

Ratiometric and simultaneous power-supply sequencing are implemented by connecting the resistor network of R1 and R2 shown in Figure 33 to the output of the power supply that must be tracked or another voltage reference source. Using Equation 6 and Equation 7, calculate the tracking resistors to initiate the  $V_{OUT2}$  slightly before, after or at the same time as  $V_{OUT1}$ . Equation 8 is the voltage difference between  $V_{OUT1}$  and  $V_{OUT2}$  at the 95% of nominal output regulation.

The  $\Delta V$  variable is 0 V for simultaneous sequencing. To minimize the effect of the inherent SS/TR to FB offset ( $V_{SSoffset}$ ) in the soft-start circuit and the offset created by the pullup-current source ( $I_{SS}$ ) and tracking resistors, the  $V_{SSoffset}$  and  $I_{SS}$  are included as variables in the equations.

To design a ratio-metric start-up in which the  $V_{OUT2}$  voltage is slightly greater than the  $V_{OUT1}$  voltage when  $V_{OUT2}$  reaches regulation, use a negative number in Equation 6 through Equation 8 for  $\Delta V$ . Equation 8 results in a positive number for applications which the  $V_{OUT2}$  is slightly lower than  $V_{OUT1}$  when  $V_{OUT2}$  regulation is achieved.

Because the SS/TR pin must be pulled below 54 mV before starting after an EN, UVLO, or thermal shutdown fault, careful selection of the tracking resistors ensures that the device restarts after a fault. The calculated R1 value from Equation 6 must be greater than the value calculated in Equation 9 to ensure the device recovers from a fault.

As the SS/TR voltage becomes more than 85% of the nominal reference voltage, the  $V_{SSoffset}$  becomes larger as the soft-start circuits gradually hands-off the regulation reference to the internal voltage reference. The SS/TR pin voltage must be greater than 1.5 V for a complete handoff to the internal voltage reference as shown in Figure 23.

$$R1 = \frac{V_{OUT2} + \Delta V}{V_{REF}} \times \frac{V_{SSoffset}}{I_{SS}} \quad (6)$$

$$R2 = \frac{V_{REF} \times R1}{V_{OUT2} + \Delta V - V_{REF}} \quad (7)$$

$$\Delta V = V_{OUT1} - V_{OUT2} \quad (8)$$

$$R1 > 2800 \times V_{OUT1} - 180 \times \Delta V \quad (9)$$

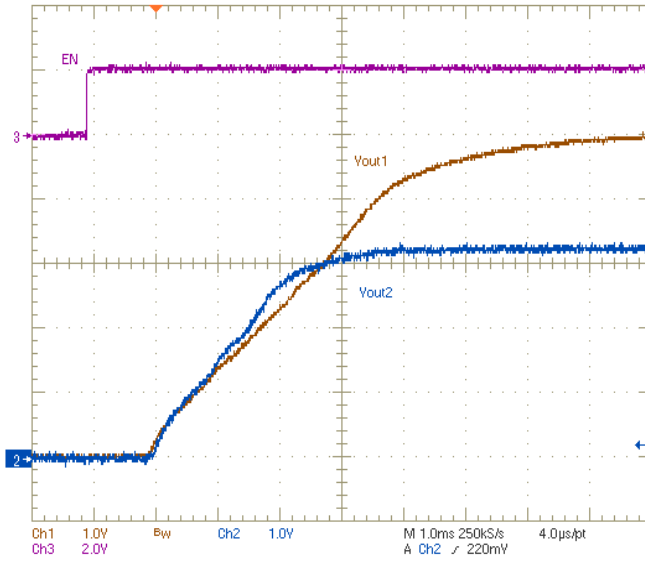

**Figure 34. Ratiometric Startup with Tracking Resistors**

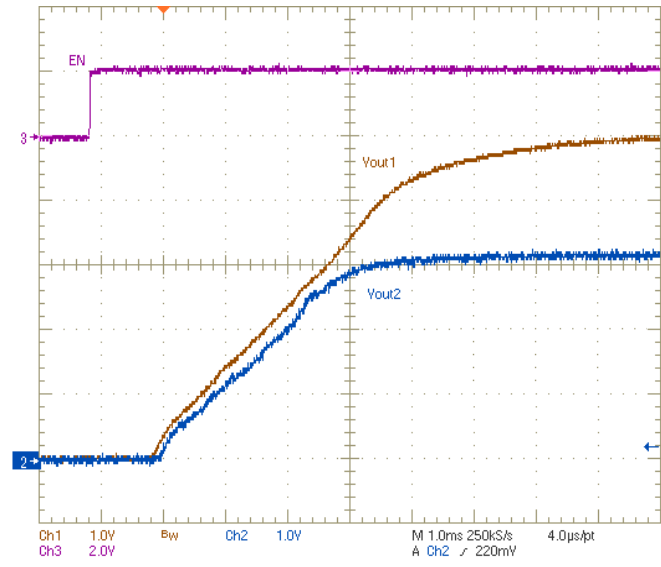

**Figure 35. Ratiometric Startup with Tracking Resistors**

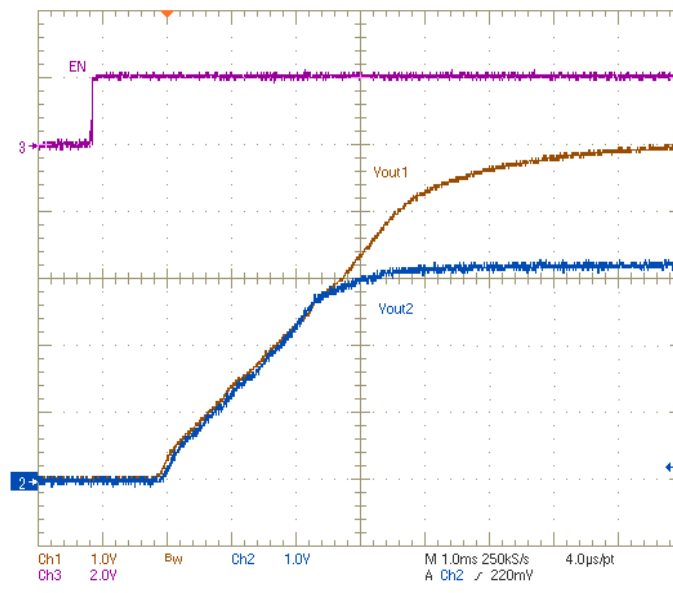

**Figure 36. Simultaneous Startup With Tracking Resistor**

### Constant Switching Frequency and Timing Resistor (RT/CLK) Pin)

The switching frequency of the TPS54541 device is adjustable over a wide range from 100 to 2500 kHz by placing a resistor between the RT/CLK pin and GND pin. The RT/CLK pin voltage is typically 0.5 V and must have a resistor to ground to set the switching frequency. To determine the timing resistance for a given switching frequency, use [Equation 10](#) or [Equation 11](#) or the curves in [Figure 5](#) and [Figure 6](#). To reduce the solution size typically set the switching frequency as high as possible. The tradeoffs of the conversion efficiency, maximum input voltage, and minimum controllable on time must be considered. The minimum controllable on time is typically 135 ns which limits the maximum operating frequency in applications with high input to output step-down ratios. The maximum switching frequency is also limited by the frequency-foldback circuit. A more detailed discussion of the maximum switching frequency is provided in the next section.

$$RT \text{ (k}\Omega\text{)} = \frac{92417}{f_{SW} \text{ (kHz)}^{0.991}} \quad (10)$$

$$f_{SW} \text{ (kHz)} = \frac{101756}{RT \text{ (k}\Omega\text{)}^{1.008}} \quad (11)$$

### Accurate Current Limit Operation and Maximum Switching Frequency

The TPS54541 device implements peak current-mode control in which the COMP pin voltage controls the peak current of the high-side MOSFET. A signal proportional to the high-side switch current and the COMP pin voltage are compared each cycle. When the peak switch current intersects the COMP control voltage, the high-side switch turns off. During overcurrent conditions that pull the output voltage low, the error amplifier increases switch current by driving the COMP pin high. The error amplifier output is clamped internally at a level which sets the peak switch current limit. The TPS54541 device provides an accurate current limit threshold with a typical current limit delay of 60 ns. With smaller inductor values, the delay results in a higher peak inductor current. The relationship between the inductor value and the peak inductor current is shown in [Figure 37](#).

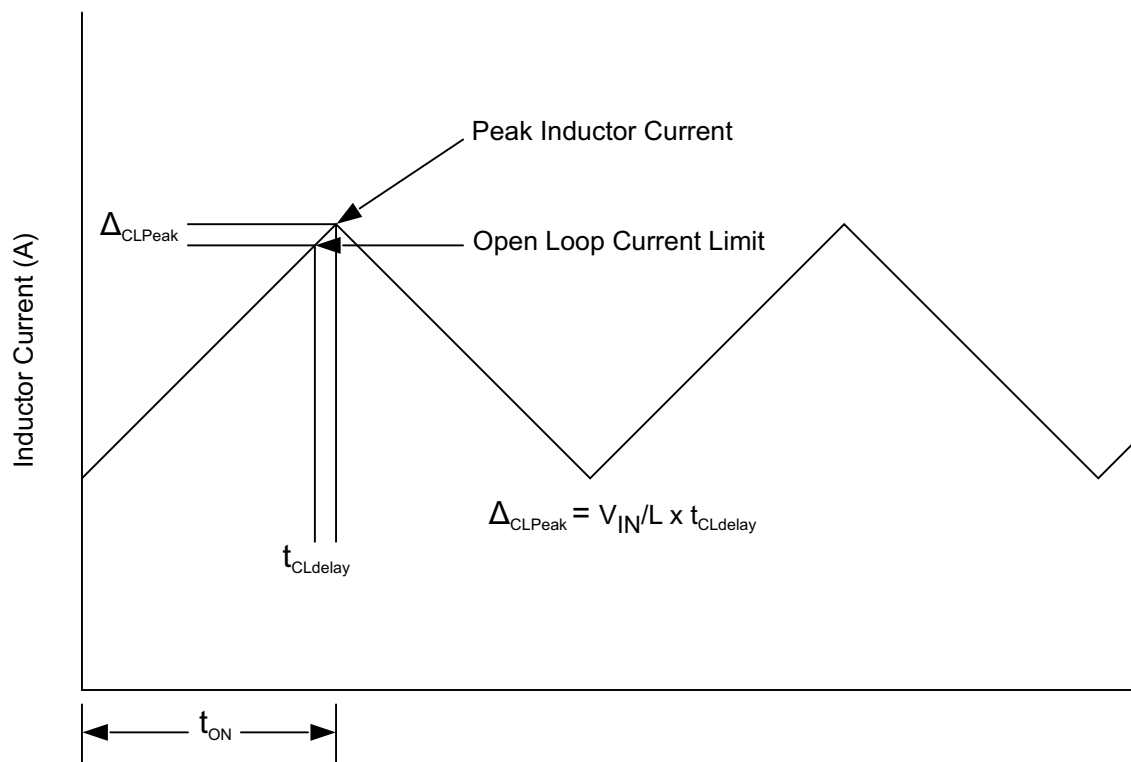

Figure 37. Current Limit Delay

To protect the converter in overload conditions at higher switching frequencies and input voltages, the TPS54541 device implements a frequency foldback. The oscillator frequency is divided by 1, 2, 4, and 8 as the FB pin voltage falls from 0.8 V to 0 V. The TPS54541 device uses a digital frequency foldback to enable synchronization to an external clock during normal startup and fault conditions. During short-circuit events, the inductor current can exceed the peak current-limit because of the high input voltage and the minimum controllable on time. When the output voltage is forced low by the shorted load, the inductor current decreases slowly during the switch off time. The frequency foldback effectively increases the off time by increasing the period of the switching cycle providing more time for the inductor current to ramp down.

With a maximum frequency-foldback ratio of 8, there is a maximum frequency at which the inductor current is controlled by frequency-foldback protection. [Equation 13](#) calculates the maximum switching frequency at which the inductor current remains under control when  $V_{OUT}$  is forced to  $V_{OUT(SC)}$ . The selected operating frequency should not exceed the calculated value.

**Equation 12** calculates the maximum switching-frequency limitation set by the minimum controllable on time and the input to output step-down ratio. Setting the switching frequency above this value causes the regulator to skip switching pulses to achieve the low duty cycle required to regulate the output voltage at maximum input voltage.

$$f_{SW(\text{max skip})} = \frac{1}{t_{\text{ON}}} \times \left( \frac{I_{\text{O}} \times R_{\text{dc}} + V_{\text{OUT}} + V_{\text{d}}}{V_{\text{IN}} - I_{\text{O}} \times R_{\text{DS(on)}} + V_{\text{d}}} \right) \quad (12)$$

$$f_{SW(\text{shift})} = \frac{f_{\text{DIV}}}{t_{\text{ON}}} \times \left( \frac{I_{\text{CL}} \times R_{\text{dc}} + V_{\text{OUT(sc)}} + V_{\text{d}}}{V_{\text{IN}} - I_{\text{CL}} \times R_{\text{DS(on)}} + V_{\text{d}}} \right) \quad (13)$$

where (for [Equation 12](#) and [Equation 13](#))

- $I_{\text{O}}$  = output current
- $I_{\text{CL}}$  = current limit
- $R_{\text{dc}}$  = inductor resistance
- $V_{\text{IN}}$  = maximum input voltage
- $V_{\text{OUT}}$  = output voltage
- $V_{\text{OUT(SC)}}$  = output voltage during short
- $V_{\text{d}}$  = diode voltage drop
- $R_{\text{DS(on)}}$  = switch on resistance
- $t_{\text{ON}}$  = controllable on time
- $f_{\text{DIV}}$  = frequency divide equals (1, 2, 4, or 8)

### Synchronization to RT/CLK Pin

The RT/CLK pin can receive a frequency synchronization signal from an external system clock. To implement this synchronization feature, connect a square wave to the RT/CLK pin through either circuit network shown in [Figure 38](#). The square wave applied to the RT/CLK pin must switch lower than 0.5 V and higher than 2.0 V and have a pulsewidth greater than 15 ns. The synchronization frequency range is 160 to 2300 kHz. The rising edge of the SW synchronizes to the falling edge of RT/CLK pin signal. Design the external synchronization circuit such that the default-frequency set resistor connects from the RT/CLK pin to ground when the synchronization signal is off. When using a low impedance signal source, the frequency set resistor connects in parallel with an AC-coupling capacitor to a termination resistor (for example, 50  $\Omega$ ) as shown in [Figure 38](#). The two resistors in the series provide the default-frequency-setting resistance when the signal source is turned off. The sum of the resistance sets the switching frequency close to the external CLK frequency. AC-coupling the synchronization signal through a 10-pF ceramic capacitor to RT/CLK pin is recommended.

The first time the RT/CLK is pulled above the PLL threshold, the TPS54541 device switches from the RT-resistor free-running frequency mode to the PLL-synchronized mode. The internal 0.5-V voltage source is removed and the RT/CLK pin becomes high impedance as the PLL begins to lock onto the external signal. The switching frequency can be higher or lower than the frequency set with the RT/CLK resistor. The device transitions from the resistor mode to the PLL mode and locks onto the external clock frequency within 78  $\mu\text{s}$ . During the transition from the PLL mode to the resistor programmed mode, the switching frequency falls to 150 kHz and then increases or decreases to the resistor programmed frequency when the 0.5-V bias voltage is reapplied to the RT/CLK resistor.

The switching frequency is divided by 8, 4, 2, and 1 as the FB pin voltage ramps from 0 to 0.8 V. The device implements a digital frequency foldback enables synchronization to an external clock during normal startup and fault conditions. [Figure 39](#), [Figure 40](#) and [Figure 41](#) show the device synchronized to an external system clock in continuous conduction mode (CCM), discontinuous conduction (DCM), and pulse skip mode (Eco-Mode).

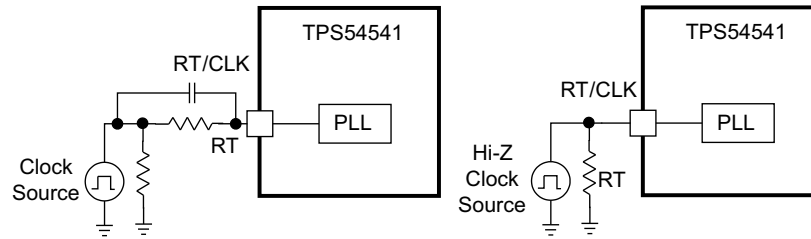

Figure 38. Synchronizing to a System Clock

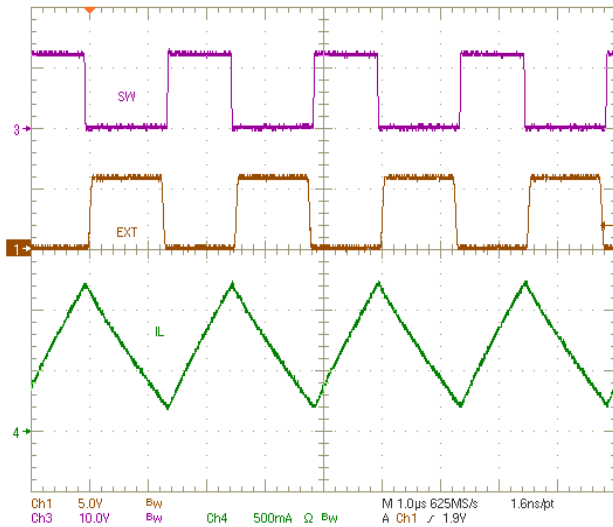

Figure 39. Plot of Synchronizing in CCM

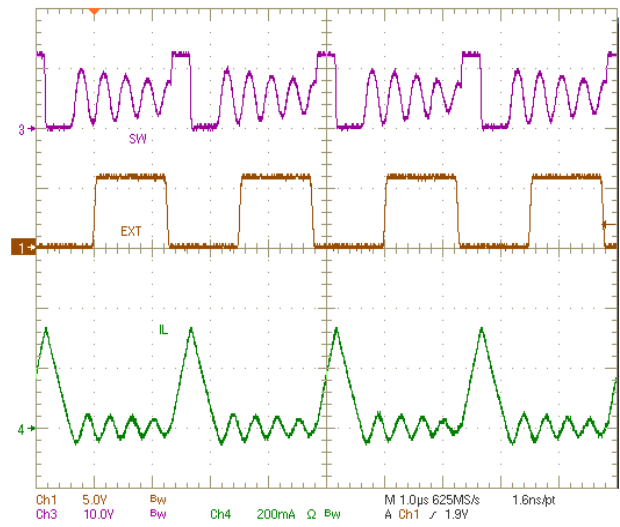

Figure 40. Plot of Synchronizing in DCM

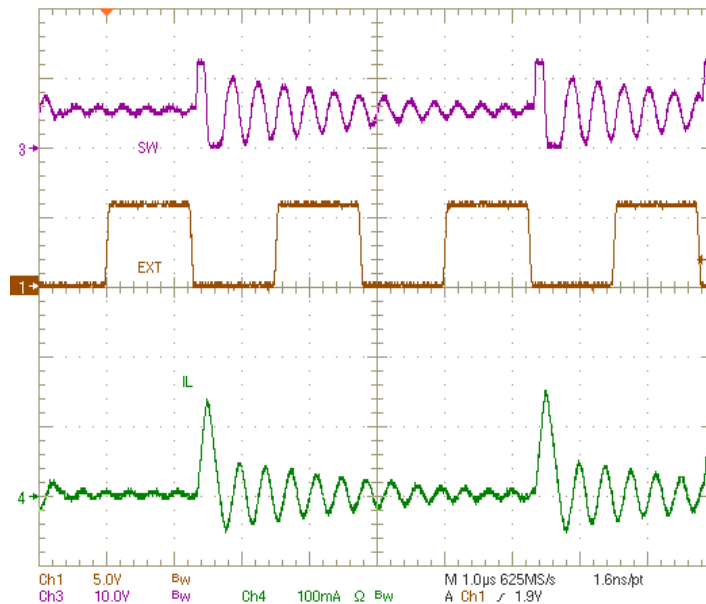

Figure 41. Plot of Synchronizing in Eco-mode

## Power Good (PWRGD Pin)

The PWRGD pin is an open-drain output. Once the FB pin is between 93% and 106% of the internal voltage reference the PWRGD pin is de-asserted and the pin floats. A pull-up resistor of 1 k $\Omega$  to a voltage source that is 5.5 V or less is recommended. A higher pullup resistance reduces the amount of current drawn from the pull up voltage source when the PWRGD pin is asserted low. A lower pull-up resistance reduces the switching noise seen on the PWRGD signal. The PWRGD is in a defined state once the VIN input voltage is greater than 2 V but with reduced current sinking capability. The PWRGD will achieve full current sinking capability as VIN input voltage approaches 3 V.

The PWRGD pin is pulled low when the FB is lower than 90% or greater than 108% of the nominal internal reference voltage. Also, the PWRGD is pulled low, if the UVLO or thermal shutdown are asserted or the EN pin pulled low.

## Overvoltage Protection

The TPS54541 device incorporates an output overvoltage-protection (OVP) circuit to minimize voltage overshoot when recovering from output fault conditions or strong unload transients in designs with low output capacitance. For example, when the power supply output is overloaded the error amplifier compares the actual output voltage to the internal reference voltage. If the FB pin voltage is lower than the internal reference voltage for a considerable time, the output of the error amplifier increases to a maximum voltage corresponding to the peak current limit threshold. When the overload condition is removed, the regulator output rises and the error amplifier output transitions to the normal operating level. In some applications, the power-supply output voltage increases faster than the response of the error amplifier output resulting in an output overshoot.

The OVP feature minimizes output overshoot when using a low-value output capacitor by comparing the FB pin voltage to the rising OVP threshold which is nominally 108% of the internal voltage reference. If the FB pin voltage is greater than the rising OVP threshold, the high-side MOSFET immediately disables to minimize output overshoot. When the FB voltage drops below the falling OVP threshold which is nominally 106% of the internal voltage reference, the high-side MOSFET resumes normal operation.

## Thermal Shutdown

The TPS54541 device provides an internal thermal shutdown to protect the device when the junction temperature exceeds 176°C. The high-side MOSFET stops switching when the junction temperature exceeds the thermal trip threshold. Once the die temperature falls below 164°C, the device reinitiates the power-up sequence controlled by discharging the SS/TR pin.

## Small-Signal Model for Loop Response

Figure 42 shows a simplified equivalent model for the TPS54541 control loop which can be simulated to check the frequency response and dynamic load response. The error amplifier is a transconductance amplifier with a  $g_{m_{EA}}$  of 350  $\mu\text{A/V}$ . The error amplifier is modeled using an ideal voltage-controlled current source. The resistor  $R_O$  and capacitor  $C_O$  model the open loop gain and frequency response of the amplifier. The 1-mV AC-voltage source between the nodes a and b effectively breaks the control loop for the frequency response measurements. Plotting  $c/a$  provides the small signal response of the frequency compensation. Plotting  $a/b$  provides the small signal response of the overall loop. The dynamic loop response is evaluated by replacing  $R_L$  with a current source with the appropriate load-step amplitude and step rate in a time-domain analysis. This equivalent model is only valid for CCM operation.

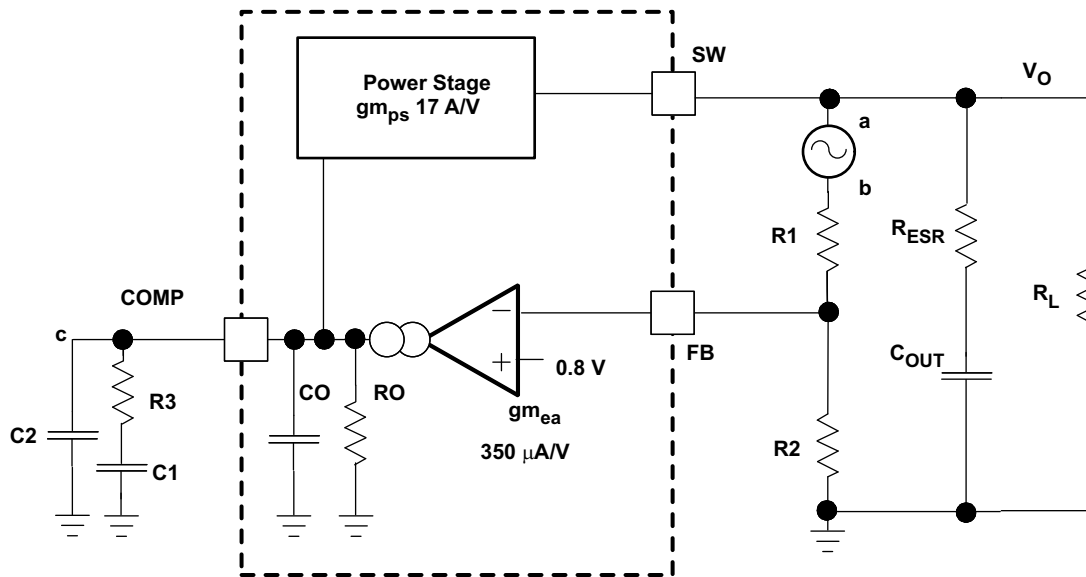

Figure 42. Small-Signal Model for Loop Response

### Simple Small-Signal Model for Peak-Current-Mode Control

Figure 43 describes a simple small-signal model used to design the frequency compensation. The TPS54541 power stage is approximated by a voltage-controlled current source (duty-cycle modulator) supplying current to the output capacitor and load resistor. The control to output transfer function is shown in Equation 14 and consists of a DC gain, one dominant pole, and one equivalent-series-resistor (ESR) zero. The quotient of the change in switch current and the change in COMP pin voltage (node c in Figure 42) is the power stage transconductance,  $gm_{PS}$ . The  $gm_{PS}$  for the TPS54541 device is 17 A/V. The low-frequency gain of the power stage is the product of the transconductance and the load resistance as shown in Equation 15.

As the load current increases and decreases, the low-frequency gain decreases and increases, respectively. This variation with the load seems problematic at first glance, but fortunately the dominant pole moves with the load current (see Equation 16). The combined effect is highlighted by the dashed line in the right half of Figure 43. As the load current decreases, the gain increases and the pole frequency lowers, keeping the 0-dB crossover frequency the same with varying load conditions. The type of output capacitor chosen determines whether the ESR zero has a profound effect on the frequency compensation design. Using high ESR aluminum electrolytic capacitors can reduce the number of frequency compensation components required to stabilize the overall loop because the phase margin is increased by the ESR zero of the output capacitor (see Equation 17).

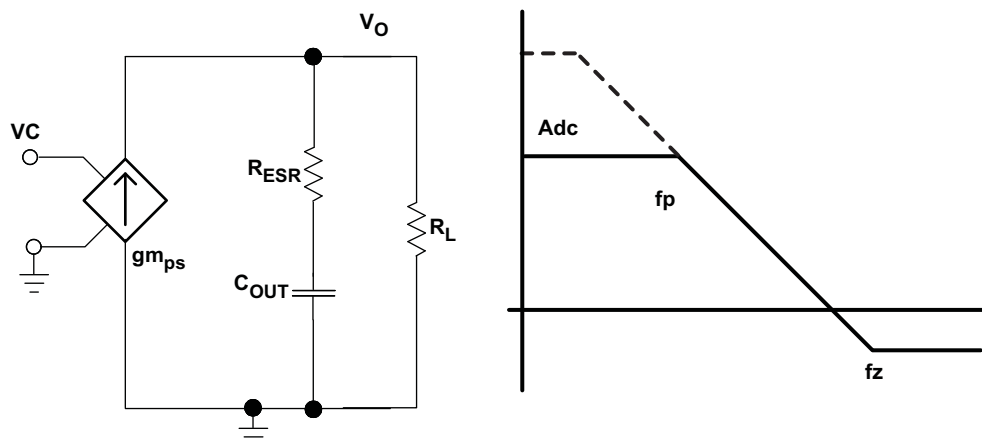

Figure 43. Simple Small-Signal Model and Frequency Response for Peak Current-Mode Control

$$\frac{V_{OUT}}{VC} = A_{dc} \times \frac{\left(1 + \frac{s}{2\pi \times f_Z}\right)}{\left(1 + \frac{s}{2\pi \times f_P}\right)} \quad (14)$$

$$A_{dc} = g_{m_{ps}} \times R_L \quad (15)$$

$$f_P = \frac{1}{C_{OUT} \times R_L \times 2\pi} \quad (16)$$

$$f_Z = \frac{1}{C_{OUT} \times R_{ESR} \times 2\pi} \quad (17)$$

### Small Signal Model for Frequency Compensation

The TPS54541 device uses a transconductance amplifier for the error amplifier and supports three of the commonly-used frequency compensation circuits. Compensation circuits Type 2A, Type 2B, and Type 1 are shown in Figure 44. Type 2 circuits are typically implemented in high bandwidth power-supply designs using low ESR output capacitors. The Type 1 circuit is used with power-supply designs with high-ESR aluminum electrolytic or tantalum capacitors. Equation 18 and Equation 19 relate the frequency response of the amplifier to the small signal model in Figure 44. The open-loop gain and bandwidth are modeled using the  $R_O$  and  $C_O$  shown in Figure 44. See the APPLICATION INFORMATION section for a design example using a Type 2A network with a low-ESR output capacitor.

Equation 18 through Equation 27 are provided as a reference. An alternative is to use WEBENCH® software tools to create a design based on the power supply requirements (go to [www.ti.com/WEBENCH](http://www.ti.com/WEBENCH) for more information).

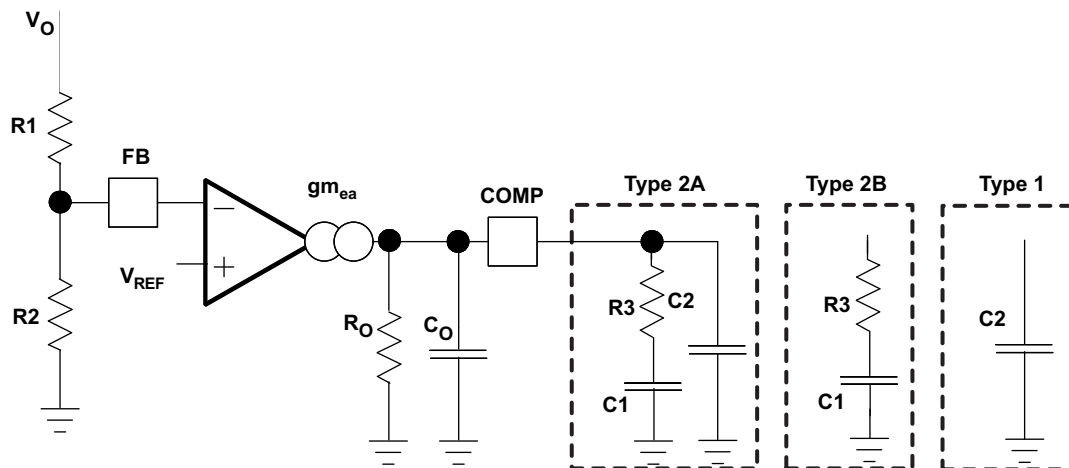

Figure 44. Types of Frequency Compensation



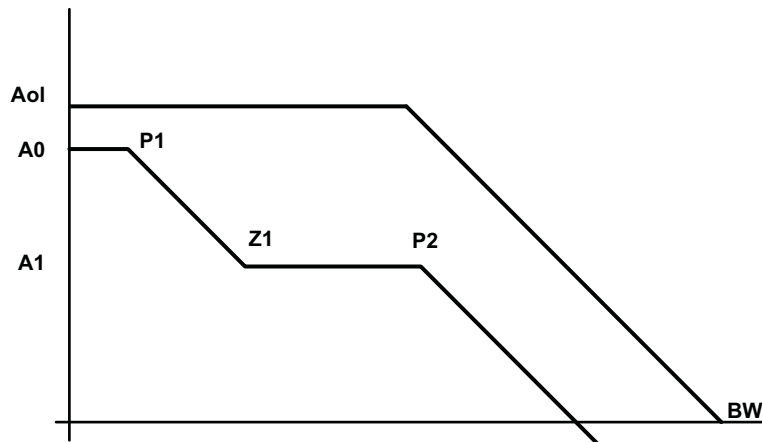

Figure 45. Frequency Response of the Type 2A and Type 2B Frequency Compensation

$$R_O = \frac{A_{ol}(V/V)}{g_{m_{ea}}} \quad (18)$$

$$C_O = \frac{g_{m_{ea}}}{2\pi \times BW \text{ (Hz)}} \quad (19)$$

$$EA = A_0 \times \frac{\left(1 + \frac{s}{2\pi \times f_{Z1}}\right)}{\left(1 + \frac{s}{2\pi \times f_{P1}}\right) \times \left(1 + \frac{s}{2\pi \times f_{P2}}\right)} \quad (20)$$

$$A_0 = g_{m_{ea}} \times R_O \times \frac{R_2}{R_1 + R_2} \quad (21)$$

$$A_1 = g_{m_{ea}} \times R_O \parallel R_3 \times \frac{R_2}{R_1 + R_2} \quad (22)$$

$$P_1 = \frac{1}{2\pi \times R_O \times C_1} \quad (23)$$

$$Z_1 = \frac{1}{2\pi \times R_3 \times C_1} \quad (24)$$

$$P_2 = \frac{1}{2\pi \times R_3 \parallel R_O \times (C_2 + C_O)} \text{ Type 2A} \quad (25)$$

$$P_2 = \frac{1}{2\pi \times R_3 \parallel R_O \times C_O} \text{ Type 2B} \quad (26)$$

$$P_2 = \frac{1}{2\pi \times R_O \times (C_2 + C_O)} \text{ Type 1} \quad (27)$$

## APPLICATION INFORMATION

### Design Guide — Step-By-Step Design Procedure

This guide illustrates the design of a high frequency switching regulator using ceramic output capacitors. A few parameters must be known in order to start the design process. These requirements are typically determined at the system level. Calculations can be done with the aid of WEBENCH or the excel spreadsheet (SLVC452) located on the product page. This example is designed to the following known parameters:

**Table 1.**

Output Voltage	3.3 V
Transient Response 1.25 A to 3.75 A load step	$\Delta V_{OUT} = 4\%$
Maximum Output Current	5 A
Input Voltage	12 V nominal 6 V to 42 V
Output Voltage Ripple	0.5% of $V_{OUT}$
Start Input Voltage (rising VIN)	5.75 V
Stop Input Voltage (falling VIN)	4.5 V

### Selecting the Switching Frequency

The first step is to choose a switching frequency for the regulator. Typically, the designer uses the highest switching frequency possible because this produces the smallest solution size. High switching frequency allows for lower value inductors and smaller output capacitors compared to a power supply that switches at a lower frequency. The switching frequency that can be selected is limited by the minimum on-time of the internal power switch, the input voltage, the output voltage and the frequency-foldback protection.

Equation 12 and Equation 13 must be used to calculate the upper limit of the switching frequency for the regulator. Choose the lower value result from the two equations. Switching frequencies higher than these values results in pulse skipping or the lack of overcurrent protection during a short circuit.

The typical minimum on time,  $t_{onmin}$ , is 135 ns for the TPS54541 device. For this example, the output voltage is 3.3 V and the maximum input voltage is 42 V. Assuming a diode voltage of 0.52 V, inductor DC resistance of 10.3 m $\Omega$ , typical switch resistance of 87 m $\Omega$  and 5 A load, from Equation 12 the maximum switch frequency to avoid pulse skipping is 680 kHz. To ensure overcurrent runaway is not a concern during short circuits use Equation 13 to determine the maximum switching frequency for frequency foldback protection. With a current-limit value of 6.3 A and short circuit output voltage of 0.1 V, the maximum switching frequency is 960 kHz.

For this design, a lower switching frequency of 400 kHz is chosen to operate comfortably below the calculated maximums. To determine the timing resistance for a given switching frequency, use Equation 10 or the curve in Figure 6. The switching frequency is set by resistor  $R_3$  shown in Figure 46. For 400 kHz operation, the closest standard value resistor is 243 k $\Omega$ .

$$f_{SW(max\ skip)} = \frac{1}{135ns} \times \left( \frac{5\text{ A} \times 10.3\text{ m}\Omega + 3.3\text{ V} + 0.52\text{ V}}{42\text{ V} - 5\text{ A} \times 87\text{ m}\Omega + 0.52\text{ V}} \right) = 680\text{ kHz} \quad (28)$$

$$f_{SW(shift)} = \frac{8}{135\text{ ns}} \times \left( \frac{6.3\text{ A} \times 10.3\text{ m}\Omega + 0.1\text{ V} + 0.52\text{ V}}{42\text{ V} - 6.3\text{ A} \times 87\text{ m}\Omega + 0.52\text{ V}} \right) = 960\text{ kHz} \quad (29)$$

$$RT\text{ (k}\Omega) = \frac{92417}{400\text{ (kHz)}^{0.991}} = 244\text{ k}\Omega \quad (30)$$

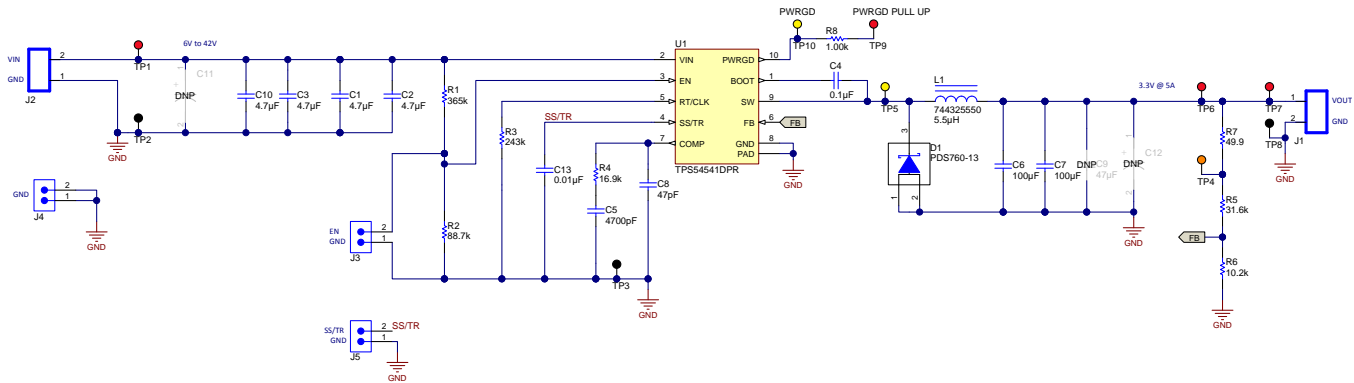

Figure 46. 3.3-V Output TPS54541 Design Example

### Output Inductor Selection ( $L_O$ )

To calculate the minimum value of the output inductor, use [Equation 31](#).

$K_{IND}$  is a ratio that represents the amount of inductor ripple current relative to the maximum output current. The inductor ripple current is filtered by the output capacitor. Therefore, choosing high inductor ripple currents impacts the selection of the output capacitor because the output capacitor must have a ripple current rating equal to or greater than the inductor ripple current. In general, the inductor ripple value is at the discretion of the designer, however, the following guidelines may be used.

For designs using low ESR output capacitors such as ceramics, a value as high as  $K_{IND} = 0.3$  may be desirable. When using higher ESR output capacitors,  $K_{IND} = 0.2$  yields better results. Because the inductor ripple current is part of the current mode PWM control system, the inductor ripple current should always be greater than 150 mA for stable PWM operation. In a wide input voltage regulator, it is best to choose relatively large inductor ripple current. This provides sufficient ripple current with the input voltage at the minimum.

For this design example,  $K_{IND} = 0.3$  and the inductor value is calculated to be 5.1  $\mu\text{H}$ . It is important that the RMS current and saturation current ratings of the inductor not be exceeded. The RMS and peak inductor current can be found from [Equation 33](#) and [Equation 34](#). For this design, the RMS inductor current is 5 A and the peak inductor current is 5.79 A. The chosen inductor is a WE 744325550, which has a saturation current rating of 12 A and an RMS current rating of 10 A. This also has a typical inductance of 5.5  $\mu\text{H}$  at no load and 4.8  $\mu\text{H}$  at 5 A load. Lastly it has a DCR of 10.3 m $\Omega$ .

As the equation set demonstrates, lower ripple currents will reduce the output voltage ripple of the regulator but will require a larger value of inductance. Selecting higher ripple currents will increase the output voltage ripple of the regulator but allow for a lower inductance value.

The current flowing through the inductor is the inductor ripple current plus the output current. During power up, faults or transient load conditions, the inductor current can increase above the peak inductor current level calculated above. In transient conditions, the inductor current can increase up to the switch current limit of the device. For this reason, the most conservative design approach is to choose an inductor with a saturation current rating equal to or greater than the switch current limit of the TPS54541 device which is nominally 7.5 A.

$$L_{O(\min)} = \frac{V_{IN(\max)} - V_{OUT}}{I_{OUT} \times K_{IND}} \times \frac{V_{OUT}}{V_{IN(\max)} \times f_{SW}} = \frac{42 \text{ V} - 3.3 \text{ V}}{5 \text{ A} \times 0.3} \times \frac{3.3 \text{ V}}{42 \text{ V} \times 400 \text{ kHz}} = 5.1 \mu\text{H} \quad (31)$$

$$I_{RIPPLE} = \frac{V_{OUT} \times (V_{IN(\max)} - V_{OUT})}{V_{IN(\max)} \times L_O \times f_{SW}} = \frac{3.3 \text{ V} \times (42 \text{ V} - 3.3 \text{ V})}{42 \text{ V} \times 4.8 \mu\text{H} \times 400 \text{ kHz}} = 1.58 \text{ A} \quad (32)$$

$$I_{L(\text{rms})} = \sqrt{I_{OUT}^2 + \frac{1}{12} \times \left( \frac{V_{OUT} \times (V_{IN(\max)} - V_{OUT})}{V_{IN(\max)} \times L_O \times f_{SW}} \right)^2} = \sqrt{(5 \text{ A})^2 + \frac{1}{12} \times \left( \frac{3.3 \text{ V} \times (42 \text{ V} - 3.3 \text{ V})}{42 \text{ V} \times 4.8 \mu\text{H} \times 400 \text{ kHz}} \right)^2} = 3.5 \text{ A} \quad (33)$$

$$I_{L(\text{peak})} = I_{OUT} + \frac{I_{RIPPLE}}{2} = 5 \text{ A} + \frac{1.58 \text{ A}}{2} = 5.79 \text{ A} \quad (34)$$

## Output Capacitor

There are three primary considerations for selecting the value of the output capacitor. The output capacitor determines the modulator pole, the output voltage ripple, and how the regulator responds to a large change in load current. The output capacitance needs to be selected based on the most stringent of these three criteria.

The desired response to a large change in the load current is the first criteria. The output capacitor needs to supply the increased load current until the regulator responds to the load step. A regulator does not respond immediately to a large, fast increase in the load current such as transitioning from no load to a full load. The regulator usually needs two or more clock cycles for the control loop to sense the change in output voltage and adjust the peak switch current in response to the higher load. The output capacitance must be large enough to supply the difference in current for two clock cycles to maintain the output voltage within the specified range. [Equation 35](#) shows the minimum output capacitance necessary, where  $\Delta I_{OUT}$  is the change in output current,  $f_{sw}$  is the regulators switching frequency and  $\Delta V_{OUT}$  is the allowable change in the output voltage. For this example, the transient load response is specified as a 4% change in  $V_{OUT}$  for a load step from 1.25 A to 3.75 A. Therefore,  $\Delta I_{OUT}$  is 3.75 A – 1.25 A = 2.5 A and  $\Delta V_{OUT} = 0.04 \times 3.3 \text{ V} = 0.13 \text{ V}$ . Using these numbers gives a minimum capacitance of 95  $\mu\text{F}$ . This value does not take the ESR of the output capacitor into account in the output voltage change. For ceramic capacitors, the ESR is usually small enough to be ignored. Aluminum electrolytic and tantalum capacitors have higher ESR that must be included in load step calculations.

The output capacitor must also be sized to absorb energy stored in the inductor when transitioning from a high to low load current. The catch diode of the regulator can not sink current so energy stored in the inductor can produce an output voltage overshoot when the load current rapidly decreases. A typical load step response is shown in [Figure 47](#). The excess energy absorbed in the output capacitor will increase the voltage on the capacitor. The capacitor must be sized to maintain the desired output voltage during these transient periods. [Equation 36](#) calculates the minimum capacitance required to keep the output voltage overshoot to a desired value, where  $L_O$  is the value of the inductor,  $I_{OH}$  is the output current under heavy load,  $I_{OL}$  is the output under light load,  $V_f$  is the peak output voltage, and  $V_i$  is the initial voltage. For this example, the worst case load step will be from 3.75 A to 1.25 A. The output voltage increases during this load transition and the stated maximum in our specification is 4 % of the output voltage. This makes  $V_f = 1.04 \times 3.3 \text{ V} = 3.43 \text{ V}$ .  $V_i$  is the initial capacitor voltage which is the nominal output voltage of 3.3 V. Using these numbers in [Equation 36](#) yields a minimum capacitance of 68  $\mu\text{F}$ .

[Equation 37](#) calculates the minimum output capacitance needed to meet the output voltage ripple specification, where  $f_{sw}$  is the switching frequency,  $V_{ORIPPLE}$  is the maximum allowable output voltage ripple, and  $I_{RIPPLE}$  is the inductor ripple current. [Equation 37](#) yields 30  $\mu\text{F}$ .

[Equation 38](#) calculates the maximum ESR an output capacitor can have to meet the output voltage ripple specification. [Equation 38](#) indicates the equivalent ESR should be less than 10 m $\Omega$ .

The most stringent criteria for the output capacitor is 95  $\mu\text{F}$  required to maintain the output voltage within regulation tolerance during a load transient.

Capacitance de-ratings for aging, temperature and dc bias increases this minimum value. For this example, two 100- $\mu\text{F}$  6.3-V type X5R ceramic capacitors with 2 m $\Omega$  of ESR are used. The derated capacitance is 130  $\mu\text{F}$ , well above the minimum required capacitance of 95  $\mu\text{F}$ .

Capacitors are generally rated for a maximum ripple current that can be filtered without degrading capacitor reliability, especially non ceramic capacitors. Some capacitor data sheets specify the Root Mean Square (RMS) value of the maximum ripple current. Equation 39 can be used to calculate the RMS ripple current that the output capacitor must support. For this example, Equation 39 yields 460 mA.

$$C_{\text{OUT}} > \frac{2 \times \Delta I_{\text{OUT}}}{f_{\text{SW}} \times \Delta V_{\text{OUT}}} = \frac{2 \times 2.5 \text{ A}}{400 \text{ kHz} \times 0.13 \text{ V}} = 95 \mu\text{F} \quad (35)$$

$$C_{\text{OUT}} > L_{\text{O}} \times \frac{\left( (I_{\text{OH}})^2 - (I_{\text{OL}})^2 \right)}{\left( (V_{\text{f}})^2 - (V_{\text{l}})^2 \right)} = 4.8 \mu\text{H} \times \frac{\left( 3.75 \text{ A}^2 - 1.25 \text{ A}^2 \right)}{\left( 3.43 \text{ V}^2 - 3.3 \text{ V}^2 \right)} = 68 \mu\text{F} \quad (36)$$

$$C_{\text{OUT}} > \frac{1}{8 \times f_{\text{SW}}} \times \frac{1}{\left( \frac{V_{\text{ORIPPLE}}}{I_{\text{RIPPLE}}} \right)} = \frac{1}{8 \times 400 \text{ kHz}} \times \frac{1}{\left( \frac{16 \text{ mV}}{1.58 \text{ A}} \right)} = 30 \mu\text{F} \quad (37)$$

$$R_{\text{ESR}} < \frac{V_{\text{ORIPPLE}}}{I_{\text{RIPPLE}}} = \frac{16 \text{ mV}}{1.58 \text{ A}} = 10 \text{ m}\Omega \quad (38)$$

$$I_{\text{COUT(rms)}} = \frac{V_{\text{OUT}} \times \left( V_{\text{IN(max)}} - V_{\text{OUT}} \right)}{\sqrt{12} \times V_{\text{IN(max)}} \times L_{\text{O}} \times f_{\text{SW}}} = \frac{3.3 \text{ V} \times (42 \text{ V} - 3.3 \text{ V})}{\sqrt{12} \times 42 \text{ V} \times 4.8 \mu\text{H} \times 400 \text{ kHz}} = 460 \text{ mA} \quad (39)$$

## Catch Diode

The TPS54541 device requires an external catch diode between the SW pin and GND. The selected diode must have a reverse voltage rating equal to or greater than  $V_{\text{IN(max)}}$ . The peak current rating of the diode must be greater than the maximum inductor current. Schottky diodes are typically a good choice for the catch diode due to their low forward voltage. The lower the forward voltage of the diode, the higher the efficiency of the regulator.

Typically, diodes with higher voltage and current ratings have higher forward voltages. A diode with a minimum of 42 V reverse voltage is preferred to allow input voltage transients up to the rated voltage of the TPS54541 device.

For the example design, the PDS760 Schottky diode is selected for its lower forward voltage and good thermal characteristics compared to smaller devices. The typical forward voltage of the PDS760 is 0.52 V at 5 A and 25°C.

The diode must also be selected with an appropriate power rating. The diode conducts the output current during the off-time of the internal power switch. The off-time of the internal switch is a function of the maximum input voltage, the output voltage, and the switching frequency. The output current during the off-time is multiplied by the forward voltage of the diode to calculate the instantaneous conduction losses of the diode. At higher switching frequencies, the AC losses of the diode must be taken into account. The AC losses of the diode are due to the charging and discharging of the junction capacitance and reverse recovery charge. Equation 40 is used to calculate the total power dissipation, including conduction losses and AC losses of the diode.

The PDS760 diode has a junction capacitance of 180 pF. Using Equation 40, the total loss in the diode at the nominal input voltage is 2.46 W.

If the power supply spends a significant amount of time at light load currents or in sleep mode, consider using a diode which has a low leakage current and slightly higher forward voltage drop.

$$P_{\text{D}} = \frac{\left( V_{\text{IN(max)}} - V_{\text{OUT}} \right) \times I_{\text{OUT}} \times V_{\text{f}}}{V_{\text{IN}}} + \frac{C_{\text{j}} \times f_{\text{SW}} \times \left( V_{\text{IN}} + V_{\text{f}} \right)^2}{2} = \frac{(42 \text{ V} - 3.3 \text{ V}) \times 5 \text{ A} \times 0.52 \text{ V}}{42 \text{ V}} + \frac{180 \text{ pF} \times 400 \text{ kHz} \times (42 \text{ V} + 0.52 \text{ V})^2}{2} = 2.46 \text{ W} \quad (40)$$

## Input Capacitor

The TPS54541 device requires a high-quality ceramic-type X5R or X7R input decoupling capacitor with at least 3  $\mu\text{F}$  of effective capacitance. Some applications will benefit from additional bulk capacitance. The effective capacitance includes any loss of capacitance due to dc bias effects. The voltage rating of the input capacitor must be greater than the maximum input voltage. The capacitor must also have a ripple current rating greater than the maximum input current ripple of the TPS54541 device. The input ripple current can be calculated using [Equation 41](#).

The value of a ceramic capacitor varies significantly with temperature and the dc bias applied to the capacitor. The capacitance variations due to temperature can be minimized by selecting a dielectric material that is more stable over temperature. X5R and X7R ceramic dielectrics are usually selected for switching regulator capacitors because they have a high capacitance to volume ratio and are fairly stable over temperature. The input capacitor must also be selected with consideration for the dc bias. The effective value of a capacitor decreases as the dc bias across a capacitor increases.

For this example design, a ceramic capacitor with at least a 42 V voltage rating is required to support transients up to the maximum input voltage. Common standard ceramic capacitor voltage ratings include 4 V, 6.3 V, 10 V, 16 V, 25 V, 50 V, or 100 V. For this example, four 4.7- $\mu\text{F}$  50-V capacitors in parallel are used. [Table 2](#) shows several choices of high voltage capacitors.

The input capacitance value determines the input ripple voltage of the regulator. The maximum input voltage ripple occurs at 50% duty cycle and can be calculated using [Equation 42](#). Using the design example values,  $I_{\text{OUT}} = 5 \text{ A}$ ,  $C_{\text{IN}} = 18.8 \mu\text{F}$ ,  $f_{\text{SW}} = 400 \text{ kHz}$ , yields an input voltage ripple of 170 mV and a rms input ripple current of 2.5 A.

$$I_{\text{Cl(rms)}} = I_{\text{OUT}} \times \sqrt{\frac{V_{\text{OUT}}}{V_{\text{IN(min)}}} \times \frac{(V_{\text{IN(min)}} - V_{\text{OUT}})}{V_{\text{IN(min)}}}} = 5 \text{ A} \times \sqrt{\frac{3.3 \text{ V}}{6 \text{ V}} \times \frac{(6 \text{ V} - 3.3 \text{ V})}{6 \text{ V}}} = 2.5 \text{ A} \quad (41)$$

$$\Delta V_{\text{IN}} = \frac{I_{\text{OUT}} \times 0.25}{C_{\text{IN}} \times f_{\text{SW}}} = \frac{5 \text{ A} \times 0.25}{18.8 \mu\text{F} \times 400 \text{ kHz}} = 170 \text{ mV} \quad (42)$$

**Table 2. Capacitor Types**

VENDOR	VALUE ( $\mu\text{F}$ )	EIA Size	VOLTAGE (V)	DIELECTRIC	COMMENTS
Murata	1 to 2.2	1210	100	X7R	GRM32 series
	1 to 4.7		50		
	1	1206	100		GRM31 series
	1 to 2.2		50		
Vishay	1 to 1.8	2220	50		VJ X7R series
	1 to 1.2		100		
	1 to 3.9	2225	50		
	1 to 1.8		100		
TDK	1 to 2.2	1812	100		C series C4532
	1.5 to 6.8		50		
	1 to 2.2	1210	100		C series C3225
	1 to 3.3		50		
AVX	1 to 4.7	1210	50	X7R dielectric series	
	1		100		
	1 to 4.7	1812	50		
	1 to 2.2		100		

## Slow Start Capacitor

The slow start capacitor determines the minimum amount of time it will take for the output voltage to reach its nominal programmed value during power up. This is useful if a load requires a controlled voltage slew rate. This is also used if the output capacitance is large and would require large amounts of current to quickly charge the capacitor to the output voltage level. The large currents necessary to charge the capacitor may make the TPS54541 device reach the current limit or excessive current draw from the input power supply may cause the input voltage rail to sag. Limiting the output voltage slew rate solves both of these problems.

The slow start time must be long enough to allow the regulator to charge the output capacitor up to the output voltage without drawing excessive current. Equation 43 can be used to find the minimum slow start time,  $T_{SS}$ , necessary to charge the output capacitor,  $C_{OUT}$ , from 10% to 90% of the output voltage,  $V_{OUT}$ , with an average slow start current of  $I_{SSavg}$ . In the example, to charge the effective output capacitance of 130  $\mu\text{F}$  up to 3.3 V with an average current of 1 A requires a 0.3-ms slow-start time.

Once the slow-start time is known, the slow-start capacitor value can be calculated using Equation 5. For the example circuit, the slow-start time is not too critical because the output capacitor value is two-times 100  $\mu\text{F}$  which does not require much current to charge to 3.3 V. The example circuit has the slow-start time set to an arbitrary value of 3.5 ms which requires a 9.3-nF slow-start capacitor calculated with Equation 44. For this design, the next larger standard value of 10 nF is used.

$$T_{SS} > \frac{C_{out} \times V_{out} \times 0.8}{I_{ssavg}} \quad (43)$$

$$C_{SS} \text{ (nF)} = \frac{T_{SS} \text{ (ms)} \times I_{SS} \text{ (\mu A)}}{V_{REF} \text{ (V)} \times 0.8} = 3.5 \text{ ms} \times \frac{1.7 \text{ \mu A}}{(0.8 \text{ V} \times 0.8)} = 9.3 \text{ nF} \quad (44)$$

## Bootstrap Capacitor Selection

A 0.1- $\mu\text{F}$  ceramic capacitor must be connected between the BOOT and SW pins for proper operation. A ceramic capacitor with X5R or better grade dielectric is recommended. The capacitor must have a 10 V or higher voltage rating.

## Undervoltage Lockout Set Point

The Undervoltage Lockout (UVLO) can be adjusted using an external voltage divider on the EN pin of the TPS54541 device. The UVLO has two thresholds, one for power up when the input voltage is rising and one for power down or brown outs when the input voltage is falling. For the example design, the supply should turn on and start switching once the input voltage increases above 5.75 V (UVLO start). After the regulator starts switching, it should continue to do so until the input voltage falls below 4.5 V (UVLO stop).

Programmable UVLO threshold voltages are set using the resistor divider of  $R_{UVLO1}$  and  $R_{UVLO2}$  between  $V_{IN}$  and ground connected to the EN pin. Equation 3 and Equation 4 calculate the resistance values necessary. For the example application, a 365 k $\Omega$  between  $V_{IN}$  and EN ( $R_{UVLO1}$ ) and a 88.7 k $\Omega$  between EN and ground ( $R_{UVLO2}$ ) are required to produce the 5.75-V and 4.5-V start and stop voltages.

$$R_{UVLO1} = \frac{V_{START} - V_{STOP}}{I_{HYS}} = \frac{5.75 \text{ V} - 4.5 \text{ V}}{3.4 \text{ \mu A}} = 368 \text{ k}\Omega \quad (45)$$

$$R_{UVLO2} = \frac{V_{ENA}}{\frac{V_{START} - V_{ENA}}{R_{UVLO1}} + I_1} = \frac{1.2 \text{ V}}{\frac{5.75 \text{ V} - 1.2 \text{ V}}{365 \text{ k}\Omega} + 1.2 \text{ \mu A}} = 88.7 \text{ k}\Omega \quad (46)$$

## Output Voltage and Feedback Resistors Selection

The voltage divider of R5 and R6 sets the output voltage. For the example design, 10.2 k $\Omega$  was selected for R6. Using Equation 2, R5 is calculated as 31.9 k $\Omega$ . The nearest standard 1% resistor is 31.6 k $\Omega$ . Due to the input current of the FB pin, the current flowing through the feedback network should be greater than 1  $\mu\text{A}$  to maintain the output voltage accuracy. This requirement is satisfied if the value of R6 is less than 800 k $\Omega$ . Choosing higher resistor values decreases quiescent current and improves efficiency at low output currents but may also introduce noise immunity problems.

$$R_{HS} = R_{LS} \times \frac{V_{OUT} - 0.8 \text{ V}}{0.8 \text{ V}} = 10.2 \text{ k}\Omega \times \left( \frac{3.3 \text{ V} - 0.8 \text{ V}}{0.8 \text{ V}} \right) = 31.9 \text{ k}\Omega \quad (47)$$

## Compensation

There are several methods to design compensation for DC-DC regulators. The method presented here is easy to calculate and ignores the effects of the slope compensation that is internal to the device. Because the slope compensation is ignored, the actual crossover frequency will be lower than the crossover frequency used in the calculations. This method assumes the crossover frequency is between the modulator pole and the ESR zero and the ESR zero is at least ten-times greater the modulator pole.

To get started, the modulator pole,  $f_{p(\text{mod})}$ , and the ESR zero,  $f_{z1}$  must be calculated using [Equation 48](#) and [Equation 49](#). For  $C_{OUT}$ , use a derated value of 130  $\mu\text{F}$ . Use equations [Equation 50](#) and [Equation 51](#) to estimate a starting point for the crossover frequency,  $f_{co}$ . For the example design,  $f_{p(\text{mod})}$  is 1850 Hz and  $f_{z(\text{mod})}$  is 610 kHz. [Equation 49](#) is the geometric mean of the modulator pole and the ESR zero and [Equation 51](#) is the mean of modulator pole and half of the switching frequency. [Equation 50](#) yields 34 kHz and [Equation 51](#) gives 19 kHz. Use the geometric mean value of [Equation 50](#) and [Equation 51](#) for an initial crossover frequency. For this example, after lab measurement, the crossover frequency target was increased to 30 kHz for an improved transient response.

Next, the compensation components are calculated. A resistor in series with a capacitor is used to create a compensating zero. A capacitor in parallel to these two components forms the compensating pole.

$$f_{p(\text{mod})} = \frac{I_{OUT(\text{max})}}{2 \times \pi \times V_{OUT} \times C_{OUT}} = \frac{5 \text{ A}}{2 \times \pi \times 3.3 \text{ V} \times 130 \mu\text{F}} = 1850 \text{ Hz} \quad (48)$$

$$f_{z(\text{mod})} = \frac{1}{2 \times \pi \times R_{ESR} \times C_{OUT}} = \frac{1}{2 \times \pi \times 1 \text{ m}\Omega \times 130 \mu\text{F}} = 610 \text{ kHz} \quad (49)$$

$$f_{co1} = \sqrt{f_{p(\text{mod})} \times f_{z(\text{mod})}} = \sqrt{1850 \text{ Hz} \times 610 \text{ kHz}} = 34 \text{ kHz} \quad (50)$$

$$f_{co2} = \sqrt{f_{p(\text{mod})} \times \frac{f_{SW}}{2}} = \sqrt{1850 \text{ Hz} \times \frac{400 \text{ kHz}}{2}} = 19 \text{ kHz} \quad (51)$$

To determine the compensation resistor,  $R_4$ , use [Equation 52](#). The typical power stage transconductance,  $g_{mps}$ , is 17 A/V. The output voltage,  $V_O$ , reference voltage,  $V_{REF}$ , and amplifier transconductance,  $g_{mea}$ , are 3.3 V, 0.8 V and 350  $\mu\text{A/V}$ , respectively.  $R_4$  is calculated to be 17 k $\Omega$  and a standard value of 16.9 k $\Omega$  is selected. Use [Equation 53](#) to set the compensation zero to the modulator pole frequency. [Equation 53](#) yields 5100 pF for compensating capacitor  $C_5$ . 4700 pF is used for this design.

$$R_4 = \left( \frac{2 \times \pi \times f_{co} \times C_{OUT}}{g_{mps}} \right) \times \left( \frac{V_{OUT}}{V_{REF} \times g_{mea}} \right) = \left( \frac{2 \times \pi \times 30 \text{ kHz} \times 130 \mu\text{F}}{17 \text{ A/V}} \right) \times \left( \frac{3.3 \text{ V}}{0.8 \text{ V} \times 350 \mu\text{A/V}} \right) = 17 \text{ k}\Omega \quad (52)$$

$$C_5 = \frac{1}{2 \times \pi \times R_4 \times f_{p(\text{mod})}} = \frac{1}{2 \times \pi \times 16.9 \text{ k}\Omega \times 1850 \text{ Hz}} = 5100 \text{ pF} \quad (53)$$

A compensation pole can be implemented if desired by adding capacitor  $C_8$  in parallel with the series combination of  $R_4$  and  $C_5$ . Use the larger value calculated from [Equation 54](#) and [Equation 55](#) for  $C_8$  to set the compensation pole. The selected value of  $C_8$  is 47 pF for this design example.

$$C_8 = \frac{C_{OUT} \times R_{ESR}}{R_4} = \frac{130 \mu\text{F} \times 1 \text{ m}\Omega}{16.9 \text{ k}\Omega} = 15 \text{ pF} \quad (54)$$

$$C_8 = \frac{1}{R_4 \times f_{sw} \times \pi} = \frac{1}{16.9 \text{ k}\Omega \times 400 \text{ kHz} \times \pi} = 47 \text{ pF} \quad (55)$$

## Discontinuous Conduction Mode and Eco-mode Boundary

With an input voltage of 12 V, the power supply enters discontinuous conduction mode when the output current is less than 560 mA. The power supply enters Eco-mode when the output current is lower than 18 mA. The input current draw is 260  $\mu\text{A}$  with no load.



## APPLICATION CURVES

Measurements are taken with standard EVM using a 12V input, 3.3V output, and 5A load unless otherwise noted.

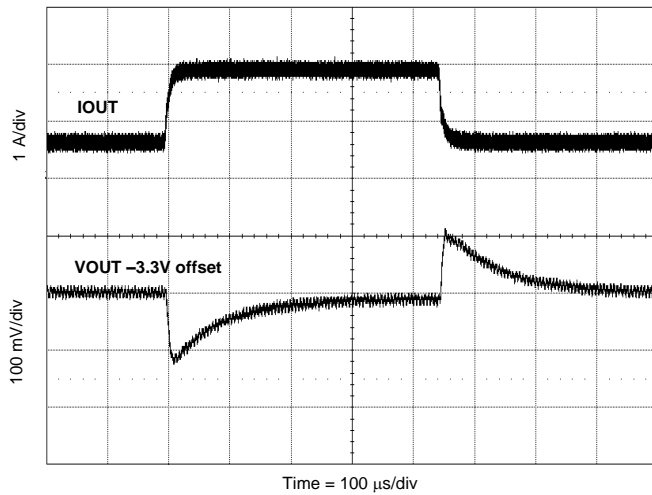

Figure 47. Load Transient

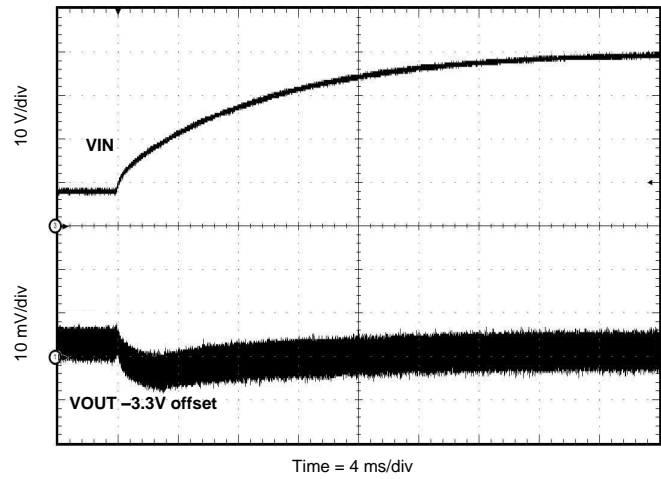

Figure 48. Line Transient (8 V to 40 V)

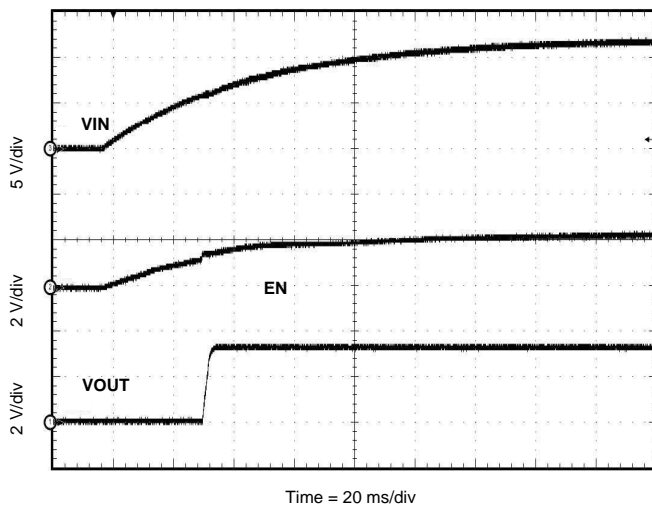

Figure 49. Start-up With VIN

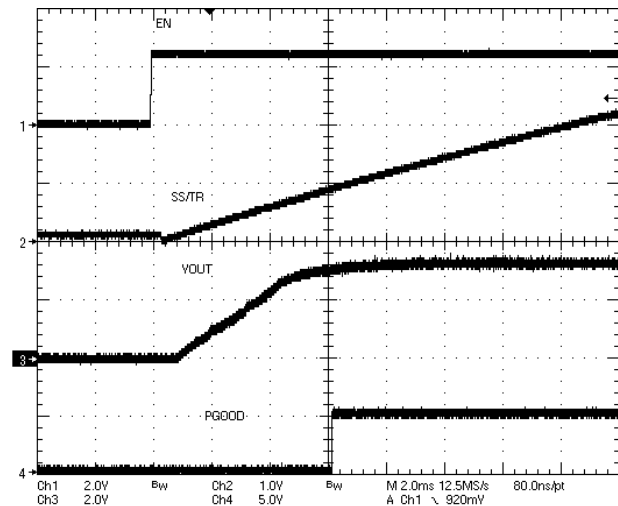

Figure 50. Start-up With EN

Measurements are taken with standard EVM using a 12V input, 3.3V output, and 5A load unless otherwise noted.

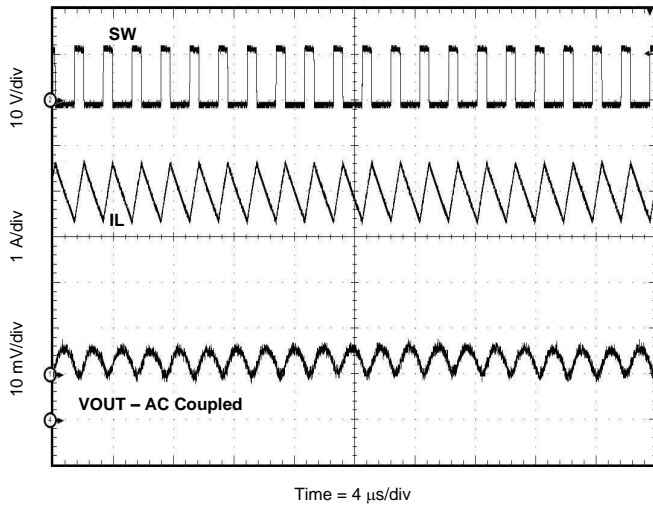

Figure 51. Output Ripple CCM

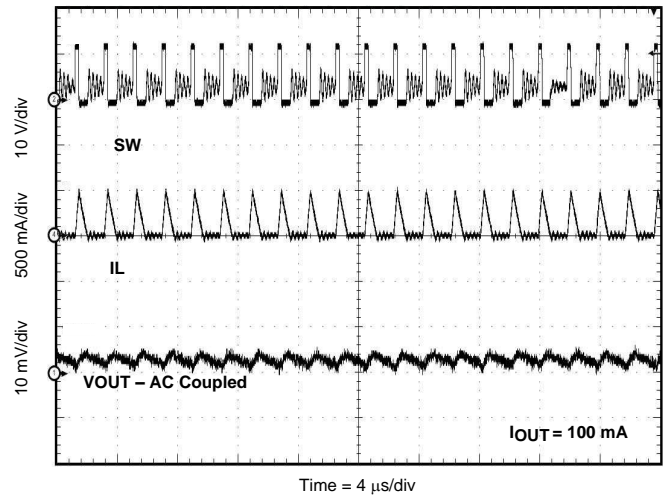

Figure 52. Output Ripple DCM

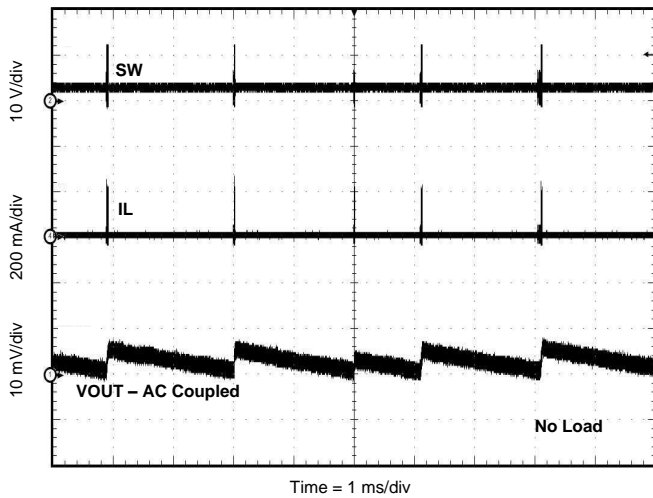

Figure 53. Output Ripple PSM

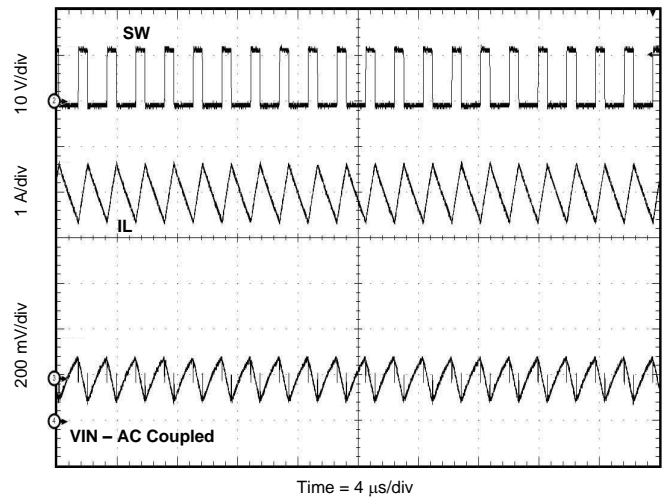

Figure 54. Input Ripple CCM

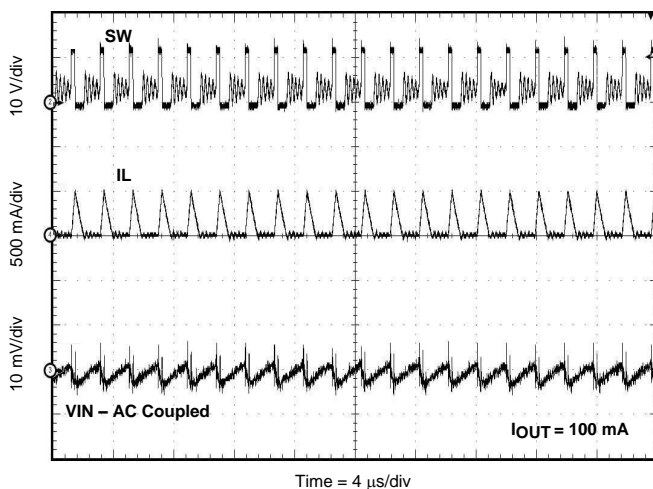

Figure 55. Input Ripple DCM

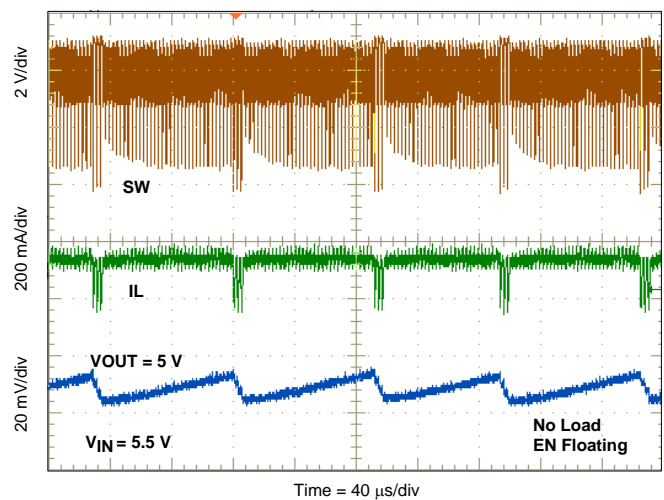

Figure 56. Low Dropout Operation

Measurements are taken with standard EVM using a 12V input, 3.3V output, and 5A load unless otherwise noted.

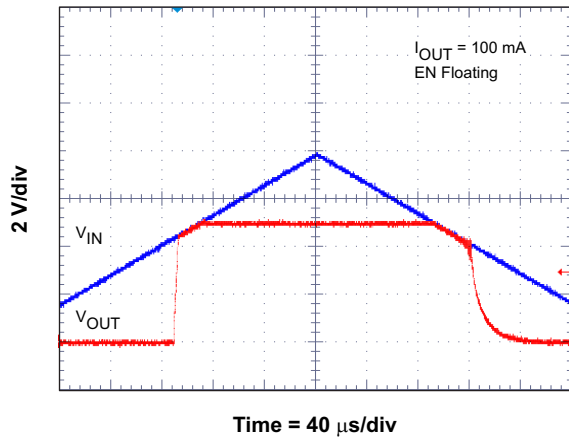

Figure 57. Low Dropout Operation

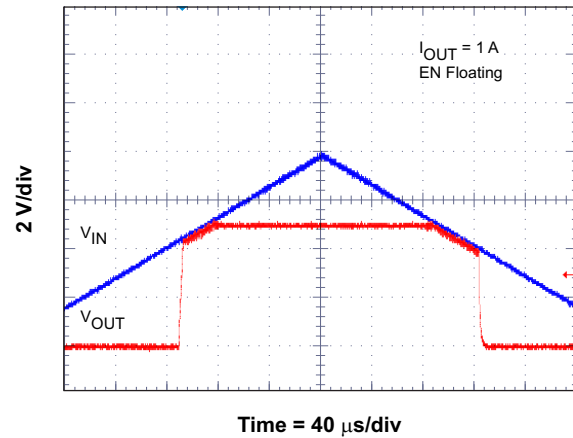

Figure 58. Low Dropout Operation

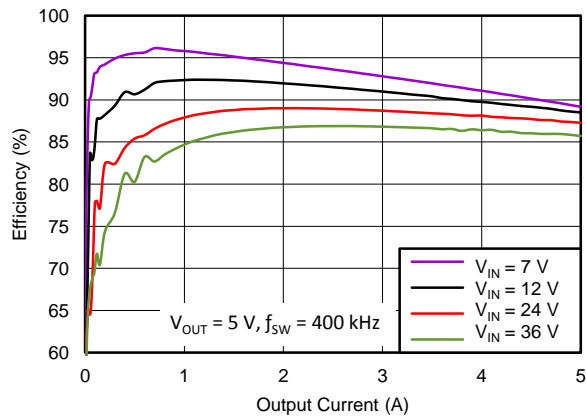

Figure 59. Efficiency vs Load Current

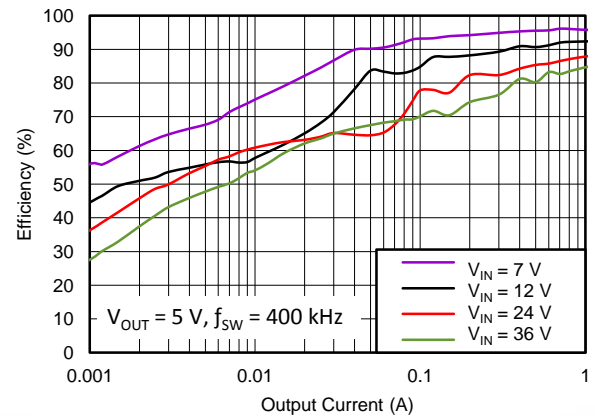

Figure 60. Light Load Efficiency

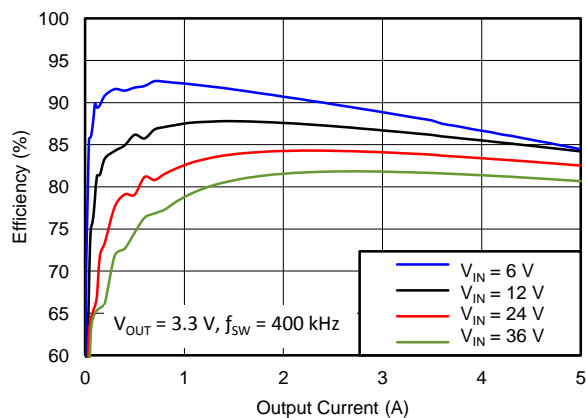

Figure 61. Efficiency vs Load Current

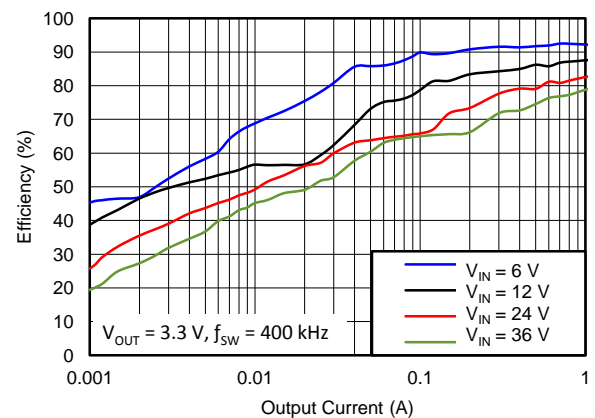

Figure 62. Light Load Efficiency

Measurements are taken with standard EVM using a 12V input, 3.3V output, and 5A load unless otherwise noted.

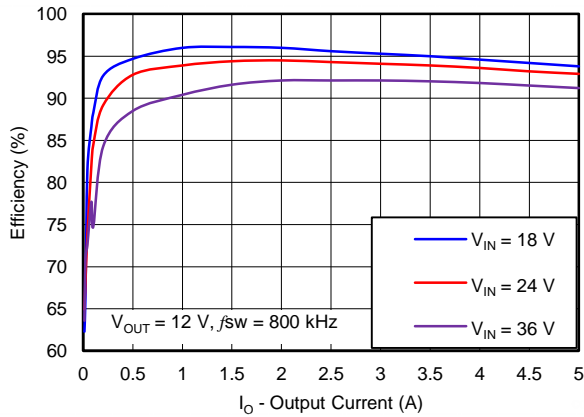

Figure 63. Efficiency vs Output Current

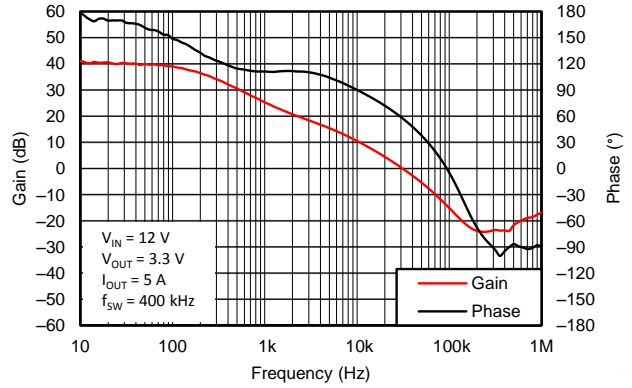

Figure 64. Overall Loop Frequency Response

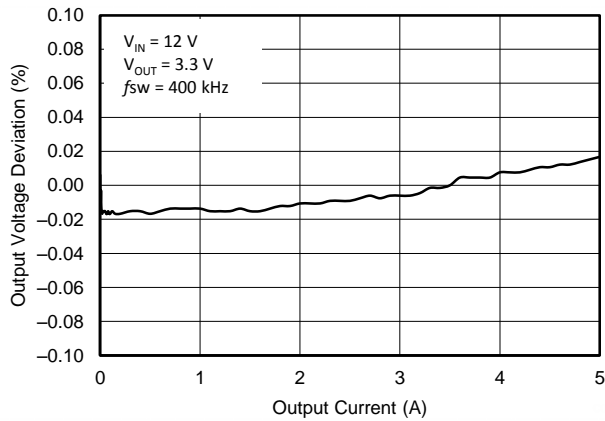

Figure 65. Regulation vs Load Current

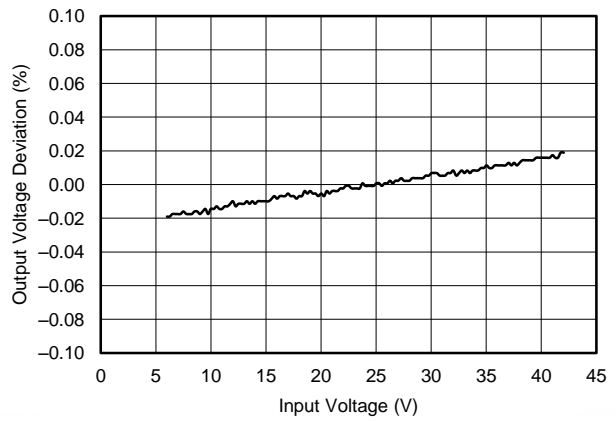

Figure 66. Regulation vs Input Voltage

## POWER DISSIPATION ESTIMATE

The following formulas estimate the TPS54541 power dissipation under CCM operation. These equations should not be used if the device is operating in DCM.

The power dissipation of the IC includes conduction loss ( $P_{COND}$ ), switching loss ( $P_{SW}$ ), gate drive loss ( $P_{GD}$ ), and supply current ( $P_Q$ ). Example calculations are shown with the 12 V typical input voltage of the design example.

$$P_{COND} = (I_{OUT})^2 \times R_{DS(on)} \times \left( \frac{V_{OUT}}{V_{IN}} \right) = 5 \text{ A}^2 \times 87 \text{ m}\Omega \times \frac{5 \text{ V}}{12 \text{ V}} = 0.958 \text{ W} \quad (56)$$

$$P_{SW} = V_{IN} \times f_{SW} \times I_{OUT} \times t_{rise} = 12 \text{ V} \times 400 \text{ kHz} \times 5 \text{ A} \times 4.9 \text{ ns} = 0.118 \text{ W} \quad (57)$$

$$P_{GD} = V_{IN} \times Q_G \times f_{SW} = 12 \text{ V} \times 3 \text{ nC} \times 400 \text{ kHz} = 0.014 \text{ W} \quad (58)$$

$$P_Q = V_{IN} \times I_Q = 12 \text{ V} \times 146 \text{ }\mu\text{A} = 0.0018 \text{ W}$$

where (for [Equation 56](#), [Equation 57](#), [Equation 58](#), and [Equation 59](#))

- $I_{OUT}$  is the output current (A)
  - $R_{DS(on)}$  is the on-resistance of the high-side MOSFET ( $\Omega$ )
  - $V_{OUT}$  is the output voltage (V)
  - $V_{IN}$  is the input voltage (V)
  - $f_{sw}$  is the switching frequency (Hz)
  - $t_{rise}$  is the SW pin voltage rise time and can be estimated by  $t_{rise} = V_{IN} \times 0.16 \text{ ns/V} + 3 \text{ ns}$
  - $Q_G$  is the total gate charge of the internal MOSFET
  - $I_Q$  is the operating nonswitching supply current
- (59)

Therefore,

$$P_{TOT} = P_{COND} + P_{SW} + P_{GD} + P_Q = 0.958 \text{ W} + 0.118 \text{ W} + 0.014 \text{ W} + 0.0018 \text{ W} = 1.092 \text{ W} \quad (60)$$

For given  $T_A$ ,

$$T_J = T_A + R_{TH} \times P_{TOT} \quad (61)$$

For given  $T_{J(MAX)} = 150^\circ\text{C}$

$$T_{A(max)} = T_{J(max)} - R_{TH} \times P_{TOT}$$

where (for [Equation 60](#), [Equation 61](#), and [Equation 62](#))

- $P_{TOT}$  is the total device power dissipation (W)
  - $T_A$  is the ambient temperature ( $^\circ\text{C}$ )
  - $T_J$  is the junction temperature ( $^\circ\text{C}$ )
  - $R_{TH}$  is the thermal resistance of the package ( $^\circ\text{C/W}$ )
  - $T_{J(MAX)}$  is maximum junction temperature ( $^\circ\text{C}$ )
  - $T_{A(MAX)}$  is maximum ambient temperature ( $^\circ\text{C}$ )
- (62)

Additional power loss occurs in the regulator circuit due to the inductor ac and dc losses and the catch diode and PCB trace resistance impacting the overall efficiency of the regulator.

### SAFE OPERATING AREA

The safe operating area (SOA) of a typical design is shown in [Figure 67](#), through [Figure 70](#) for 3.3 V, 5 V, and 12 V outputs and varying amounts of forced air flow. The temperature derating curves represent the conditions at which the internal components and external components are at or below the manufacturer’s maximum operating temperatures. Derating limits apply to devices soldered directly to a double-sided PCB with 2-oz copper, similar to the EVM. Careful attention must be paid to the other components chosen for the design, especially the catch diode. In most applications the thermal performance will be limited by the catch diode. When operating at high duty cycles or in the high end of the switching frequency range the TPS54541's thermal performance can be the limiting factor.

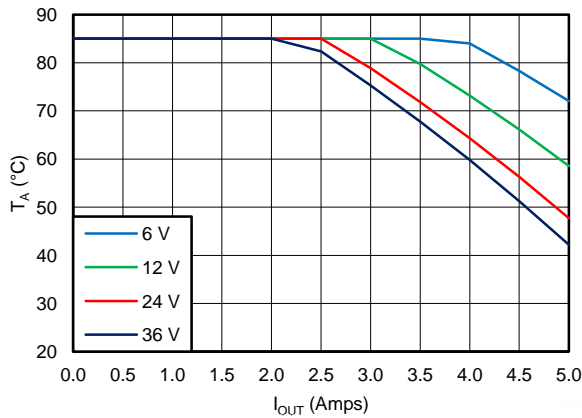

**Figure 67. 3.3V Outputs**

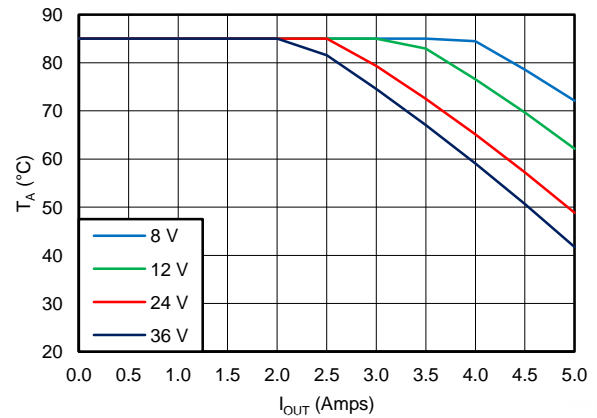

**Figure 68. 5V Outputs**

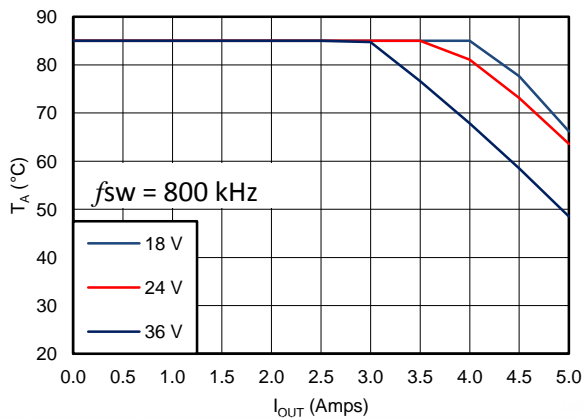

**Figure 69. 12V Outputs**

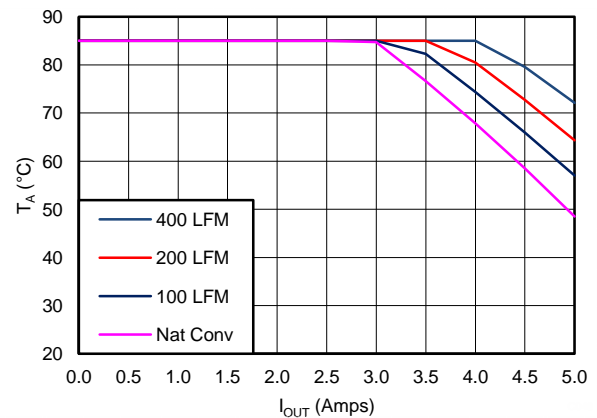

**Figure 70. Air Flow Conditions**  
 $V_{IN} = 36\text{ V}, V_O = 12\text{ V}$

## LAYOUT

Layout is a critical portion of good power supply design. There are several signal paths that conduct fast-changing currents or voltages that interact with stray inductance or parasitic capacitance to generate noise or degrade performance. To reduce parasitic effects, bypass the VIN pin to ground with a low-ESR ceramic bypass-capacitor with X5R or X7R dielectric. Take care to minimize the loop area formed by the bypass-capacitor connections, the VIN pin, and the anode of the catch diode. See Figure 71 for a PCB layout example. The GND pin must be tied directly to the power pad under the IC and the power pad.

Connect the power pad to internal PCB ground planes using multiple vias directly under the IC. Route the SW pin to the cathode of the catch diode and to the output inductor. Because the SW connection is the switching node, the catch diode and output inductor must be located close to the SW pins, and the area of the PCB conductor minimized to prevent excessive capacitive coupling. For operation at full rated load, the top-side ground area must provide adequate heat dissipating area. The RT/CLK pin is sensitive to noise so the RT resistor must be located as close as possible to the IC and routed with minimal lengths of trace. The additional external components are placed approximately as shown. Obtaining acceptable performance with alternate PCB layouts is possible, however this layout produces good results and is meant as a guideline.

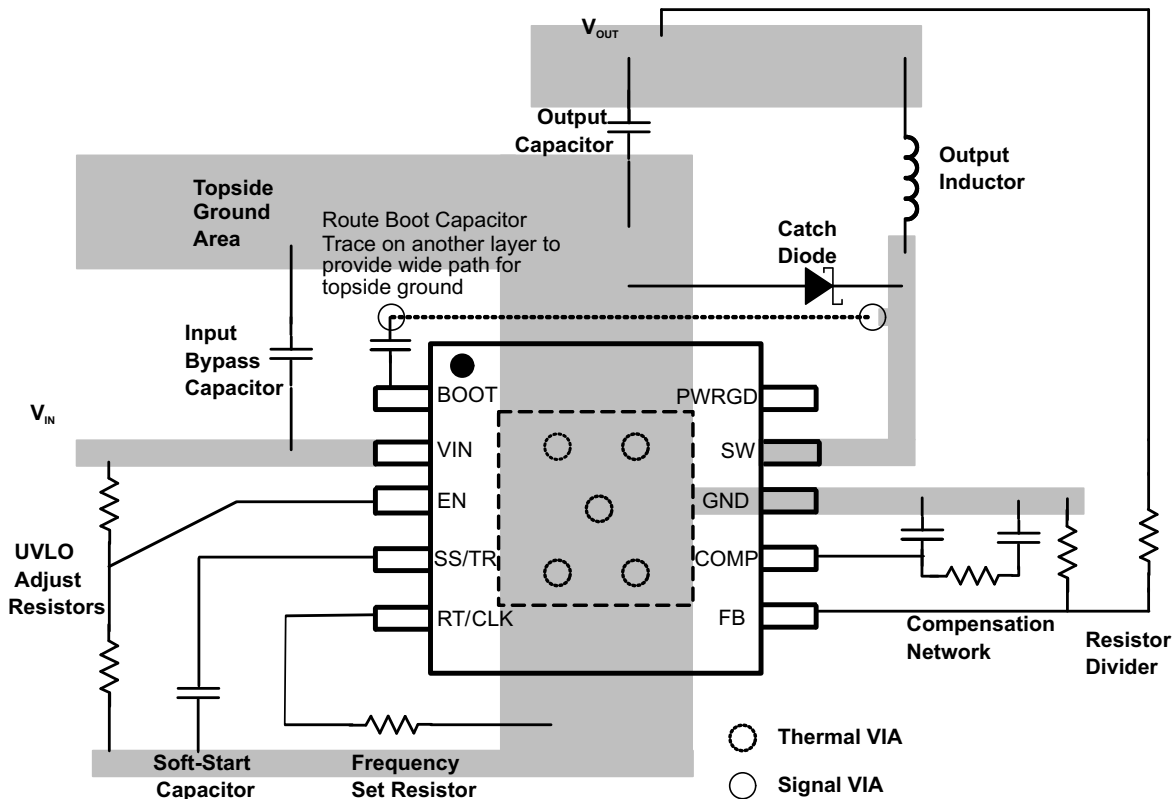

Figure 71. PCB Layout Example

### Estimated Circuit Area

Boxing in the components in the design of Figure 46 the estimated printed circuit board area is 1.025 in<sup>2</sup> (661 mm<sup>2</sup>). This area does not include test points or connectors.

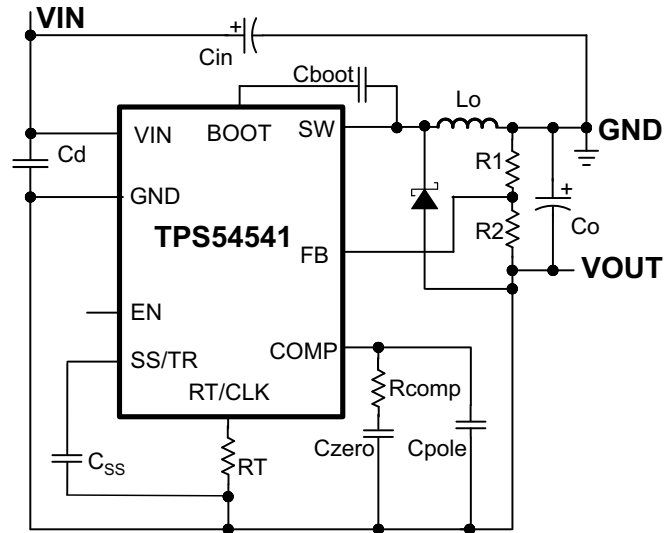

Figure 72. TPS54541 Inverting Power Supply Based on the Application Note, [SLVA317](#)

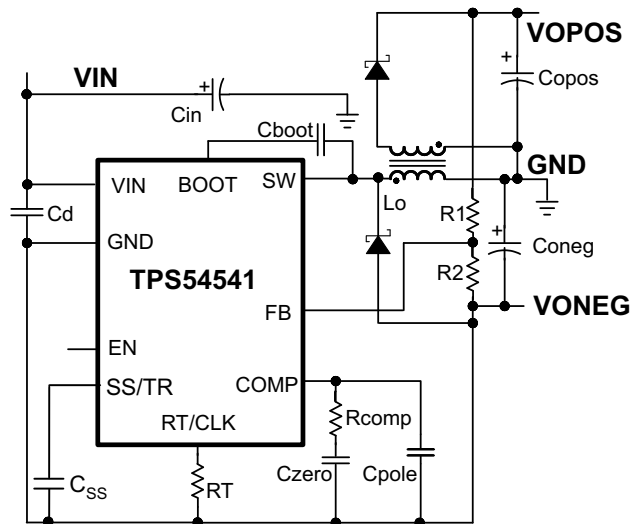

Figure 73. TPS54541 Split Rail Power Supply Based on the Application Note, [SLVA369](#)



**PACKAGING INFORMATION**

Orderable Device	Status (1)	Package Type	Package Drawing	Pins	Package Qty	Eco Plan (2)	Lead/Ball Finish (6)	MSL Peak Temp (3)	Op Temp (°C)	Device Marking (4/5)	Samples
TPS54541DPRR	ACTIVE	WSON	DPR	10	3000	TBD	Call TI	Call TI	-40 to 85		<a href="#">Samples</a>
TPS54541DPRT	ACTIVE	WSON	DPR	10	250	TBD	Call TI	Call TI	-40 to 85		<a href="#">Samples</a>

(1) The marketing status values are defined as follows:

**ACTIVE:** Product device recommended for new designs.

**LIFEBUY:** TI has announced that the device will be discontinued, and a lifetime-buy period is in effect.

**NRND:** Not recommended for new designs. Device is in production to support existing customers, but TI does not recommend using this part in a new design.

**PREVIEW:** Device has been announced but is not in production. Samples may or may not be available.

**OBSOLETE:** TI has discontinued the production of the device.

(2) Eco Plan - The planned eco-friendly classification: Pb-Free (RoHS), Pb-Free (RoHS Exempt), or Green (RoHS & no Sb/Br) - please check <http://www.ti.com/productcontent> for the latest availability information and additional product content details.

**TBD:** The Pb-Free/Green conversion plan has not been defined.

**Pb-Free (RoHS):** TI's terms "Lead-Free" or "Pb-Free" mean semiconductor products that are compatible with the current RoHS requirements for all 6 substances, including the requirement that lead not exceed 0.1% by weight in homogeneous materials. Where designed to be soldered at high temperatures, TI Pb-Free products are suitable for use in specified lead-free processes.

**Pb-Free (RoHS Exempt):** This component has a RoHS exemption for either 1) lead-based flip-chip solder bumps used between the die and package, or 2) lead-based die adhesive used between the die and leadframe. The component is otherwise considered Pb-Free (RoHS compatible) as defined above.

**Green (RoHS & no Sb/Br):** TI defines "Green" to mean Pb-Free (RoHS compatible), and free of Bromine (Br) and Antimony (Sb) based flame retardants (Br or Sb do not exceed 0.1% by weight in homogeneous material)

(3) MSL, Peak Temp. - The Moisture Sensitivity Level rating according to the JEDEC industry standard classifications, and peak solder temperature.

(4) There may be additional marking, which relates to the logo, the lot trace code information, or the environmental category on the device.

(5) Multiple Device Markings will be inside parentheses. Only one Device Marking contained in parentheses and separated by a "~" will appear on a device. If a line is indented then it is a continuation of the previous line and the two combined represent the entire Device Marking for that device.

(6) Lead/Ball Finish - Orderable Devices may have multiple material finish options. Finish options are separated by a vertical ruled line. Lead/Ball Finish values may wrap to two lines if the finish value exceeds the maximum column width.

**Important Information and Disclaimer:** The information provided on this page represents TI's knowledge and belief as of the date that it is provided. TI bases its knowledge and belief on information provided by third parties, and makes no representation or warranty as to the accuracy of such information. Efforts are underway to better integrate information from third parties. TI has taken and continues to take reasonable steps to provide representative and accurate information but may not have conducted destructive testing or chemical analysis on incoming materials and chemicals. TI and TI suppliers consider certain information to be proprietary, and thus CAS numbers and other limited information may not be available for release.

In no event shall TI's liability arising out of such information exceed the total purchase price of the TI part(s) at issue in this document sold by TI to Customer on an annual basis.

**TAPE AND REEL INFORMATION**

**QUADRANT ASSIGNMENTS FOR PIN 1 ORIENTATION IN TAPE**

\*All dimensions are nominal

Device	Package Type	Package Drawing	Pins	SPQ	Reel Diameter (mm)	Reel Width W1 (mm)	A0 (mm)	B0 (mm)	K0 (mm)	P1 (mm)	W (mm)	Pin1 Quadrant
TPS54541DPRR	WSON	DPR	10	3000	330.0	12.4	4.25	4.25	1.15	8.0	12.0	Q2
TPS54541DPRT	WSON	DPR	10	250	180.0	12.4	4.25	4.25	1.15	8.0	12.0	Q2

**TAPE AND REEL BOX DIMENSIONS**

\*All dimensions are nominal

Device	Package Type	Package Drawing	Pins	SPQ	Length (mm)	Width (mm)	Height (mm)
TPS54541DPRR	WSON	DPR	10	3000	367.0	367.0	35.0
TPS54541DPRT	WSON	DPR	10	250	210.0	185.0	35.0

DPR (S-PWSON-N10)

PLASTIC SMALL OUTLINE NO-LEAD

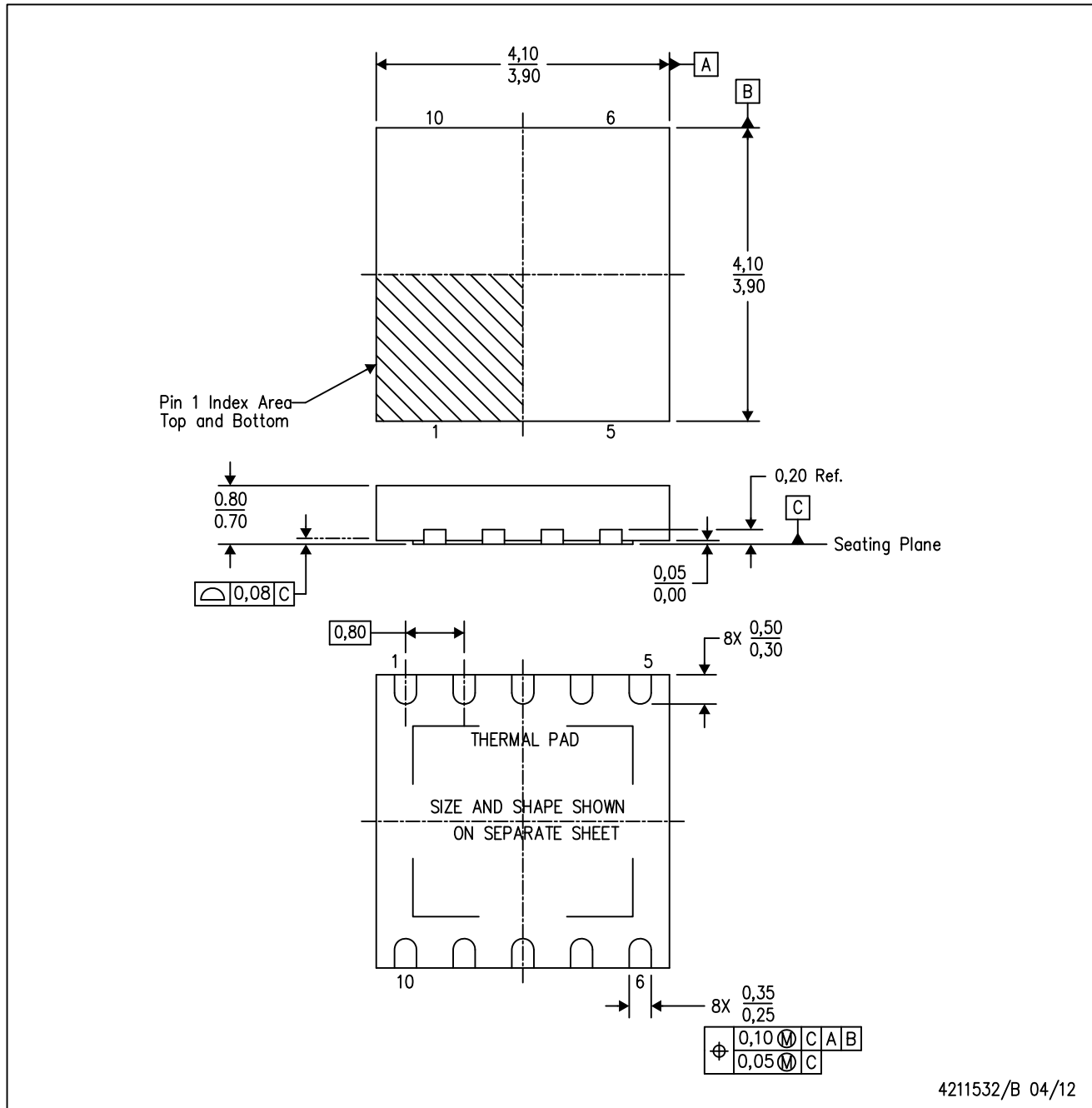

4211532/B 04/12

- NOTES:
- A. All linear dimensions are in millimeters. Dimensioning and tolerancing per ASME Y14.5M-1994.
  - B. This drawing is subject to change without notice.
  - C. SON (Small Outline No-Lead) package configuration.
  - D. The package thermal pad must be soldered to the board for thermal and mechanical performance.
  - E. See the additional figure in the Product Data Sheet for details regarding the exposed thermal pad features and dimensions.

## THERMAL PAD MECHANICAL DATA

DPR (S-PWSON-N10)

PLASTIC SMALL OUTLINE NO-LEAD

### THERMAL INFORMATION

This package incorporates an exposed thermal pad that is designed to be attached directly to an external heatsink. The thermal pad must be soldered directly to the printed circuit board (PCB). After soldering, the PCB can be used as a heatsink. In addition, through the use of thermal vias, the thermal pad can be attached directly to the appropriate copper plane shown in the electrical schematic for the device, or alternatively, can be attached to a special heatsink structure designed into the PCB. This design optimizes the heat transfer from the integrated circuit (IC).

For information on the Quad Flatpack No-Lead (QFN) package and its advantages, refer to Application Report, QFN/SON PCB Attachment, Texas Instruments Literature No. SLUA271. This document is available at [www.ti.com](http://www.ti.com).

The exposed thermal pad dimensions for this package are shown in the following illustration.

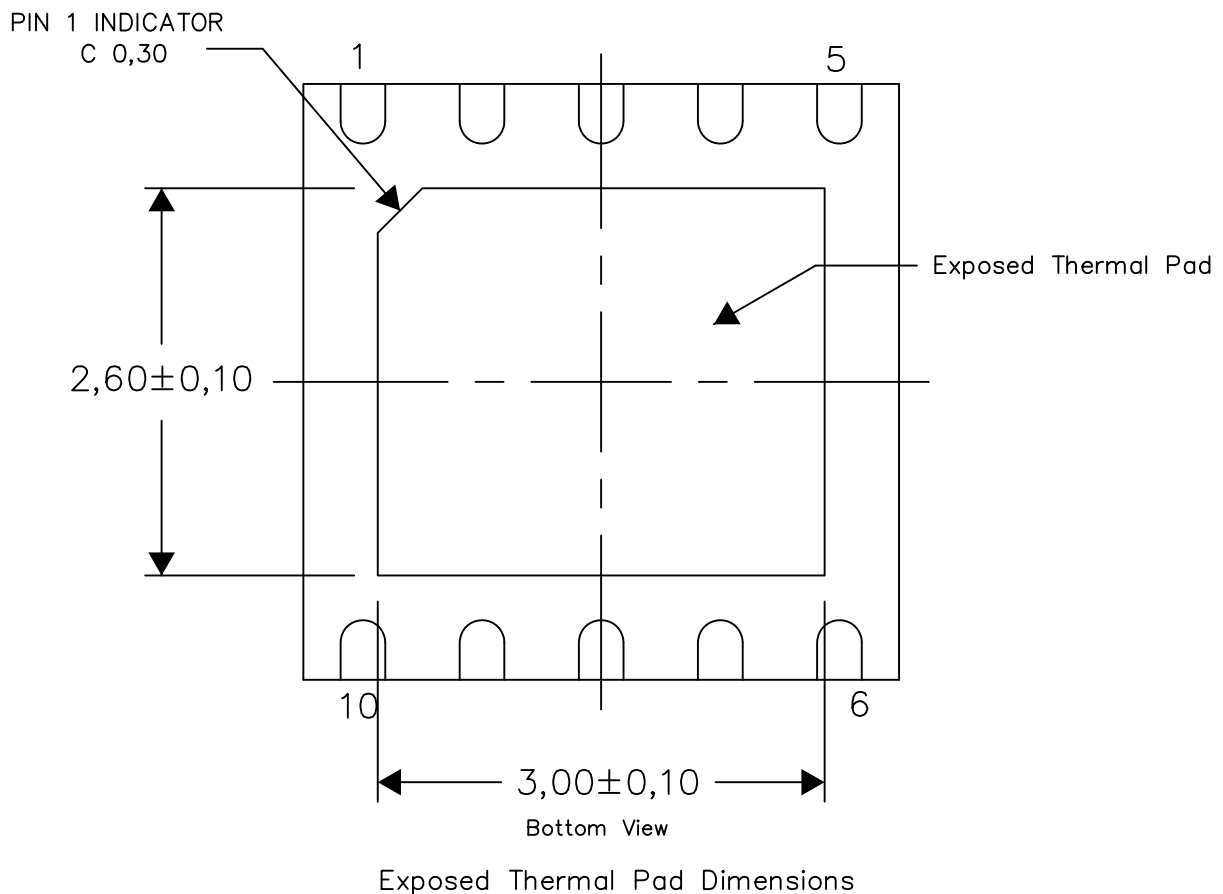

4211551/C 12/13

NOTES: All linear dimensions are in millimeters

DPR (S-PWSON-N10)

PLASTIC SMALL OUTLINE NO-LEAD

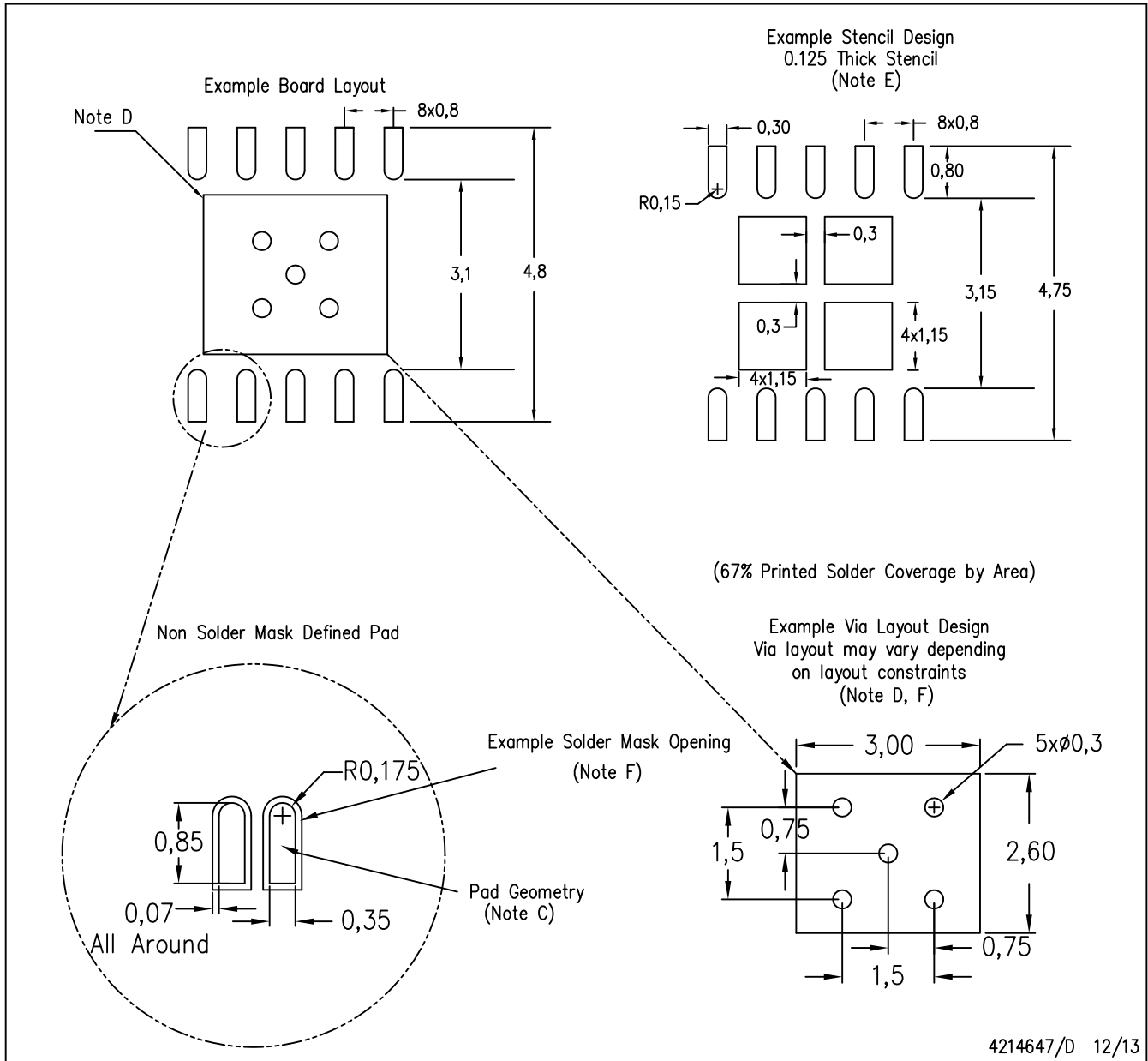

- NOTES:
- All linear dimensions are in millimeters.
  - This drawing is subject to change without notice.
  - Publication IPC-7351 is recommended for alternate designs.
  - This package is designed to be soldered to a thermal pad on the board. Refer to Application Note, Quad Flat-Pack Packages, Texas Instruments Literature No. SLUA271, and also the Product Data Sheets for specific thermal information, via requirements, and recommended board layout. These documents are available at [www.ti.com](http://www.ti.com) <<http://www.ti.com>>.
  - Laser cutting apertures with trapezoidal walls and also rounding corners will offer better paste release. Customers should contact their board assembly site for stencil design recommendations. Refer to IPC 7525 for stencil design considerations.
  - Customers should contact their board fabrication site for recommended solder mask tolerances and via tenting recommendations for vias placed in the thermal pad.

## IMPORTANT NOTICE

Texas Instruments Incorporated and its subsidiaries (TI) reserve the right to make corrections, enhancements, improvements and other changes to its semiconductor products and services per JESD46, latest issue, and to discontinue any product or service per JESD48, latest issue. Buyers should obtain the latest relevant information before placing orders and should verify that such information is current and complete. All semiconductor products (also referred to herein as "components") are sold subject to TI's terms and conditions of sale supplied at the time of order acknowledgment.

TI warrants performance of its components to the specifications applicable at the time of sale, in accordance with the warranty in TI's terms and conditions of sale of semiconductor products. Testing and other quality control techniques are used to the extent TI deems necessary to support this warranty. Except where mandated by applicable law, testing of all parameters of each component is not necessarily performed.

TI assumes no liability for applications assistance or the design of Buyers' products. Buyers are responsible for their products and applications using TI components. To minimize the risks associated with Buyers' products and applications, Buyers should provide adequate design and operating safeguards.

TI does not warrant or represent that any license, either express or implied, is granted under any patent right, copyright, mask work right, or other intellectual property right relating to any combination, machine, or process in which TI components or services are used. Information published by TI regarding third-party products or services does not constitute a license to use such products or services or a warranty or endorsement thereof. Use of such information may require a license from a third party under the patents or other intellectual property of the third party, or a license from TI under the patents or other intellectual property of TI.

Reproduction of significant portions of TI information in TI data books or data sheets is permissible only if reproduction is without alteration and is accompanied by all associated warranties, conditions, limitations, and notices. TI is not responsible or liable for such altered documentation. Information of third parties may be subject to additional restrictions.

Resale of TI components or services with statements different from or beyond the parameters stated by TI for that component or service voids all express and any implied warranties for the associated TI component or service and is an unfair and deceptive business practice. TI is not responsible or liable for any such statements.

Buyer acknowledges and agrees that it is solely responsible for compliance with all legal, regulatory and safety-related requirements concerning its products, and any use of TI components in its applications, notwithstanding any applications-related information or support that may be provided by TI. Buyer represents and agrees that it has all the necessary expertise to create and implement safeguards which anticipate dangerous consequences of failures, monitor failures and their consequences, lessen the likelihood of failures that might cause harm and take appropriate remedial actions. Buyer will fully indemnify TI and its representatives against any damages arising out of the use of any TI components in safety-critical applications.

In some cases, TI components may be promoted specifically to facilitate safety-related applications. With such components, TI's goal is to help enable customers to design and create their own end-product solutions that meet applicable functional safety standards and requirements. Nonetheless, such components are subject to these terms.

No TI components are authorized for use in FDA Class III (or similar life-critical medical equipment) unless authorized officers of the parties have executed a special agreement specifically governing such use.

Only those TI components which TI has specifically designated as military grade or "enhanced plastic" are designed and intended for use in military/aerospace applications or environments. Buyer acknowledges and agrees that any military or aerospace use of TI components which have **not** been so designated is solely at the Buyer's risk, and that Buyer is solely responsible for compliance with all legal and regulatory requirements in connection with such use.

TI has specifically designated certain components as meeting ISO/TS16949 requirements, mainly for automotive use. In any case of use of non-designated products, TI will not be responsible for any failure to meet ISO/TS16949.

### Products

Audio	<a href="http://www.ti.com/audio">www.ti.com/audio</a>
Amplifiers	<a href="http://amplifier.ti.com">amplifier.ti.com</a>
Data Converters	<a href="http://dataconverter.ti.com">dataconverter.ti.com</a>
DLP® Products	<a href="http://www.dlp.com">www.dlp.com</a>
DSP	<a href="http://dsp.ti.com">dsp.ti.com</a>
Clocks and Timers	<a href="http://www.ti.com/clocks">www.ti.com/clocks</a>
Interface	<a href="http://interface.ti.com">interface.ti.com</a>
Logic	<a href="http://logic.ti.com">logic.ti.com</a>
Power Mgmt	<a href="http://power.ti.com">power.ti.com</a>
Microcontrollers	<a href="http://microcontroller.ti.com">microcontroller.ti.com</a>
RFID	<a href="http://www.ti-rfid.com">www.ti-rfid.com</a>
OMAP Applications Processors	<a href="http://www.ti.com/omap">www.ti.com/omap</a>
Wireless Connectivity	<a href="http://www.ti.com/wirelessconnectivity">www.ti.com/wirelessconnectivity</a>

### Applications

Automotive and Transportation	<a href="http://www.ti.com/automotive">www.ti.com/automotive</a>
Communications and Telecom	<a href="http://www.ti.com/communications">www.ti.com/communications</a>
Computers and Peripherals	<a href="http://www.ti.com/computers">www.ti.com/computers</a>
Consumer Electronics	<a href="http://www.ti.com/consumer-apps">www.ti.com/consumer-apps</a>
Energy and Lighting	<a href="http://www.ti.com/energy">www.ti.com/energy</a>
Industrial	<a href="http://www.ti.com/industrial">www.ti.com/industrial</a>
Medical	<a href="http://www.ti.com/medical">www.ti.com/medical</a>
Security	<a href="http://www.ti.com/security">www.ti.com/security</a>
Space, Avionics and Defense	<a href="http://www.ti.com/space-avionics-defense">www.ti.com/space-avionics-defense</a>
Video and Imaging	<a href="http://www.ti.com/video">www.ti.com/video</a>

### TI E2E Community

[e2e.ti.com](http://e2e.ti.com)