

2.95-V to 6-V Input, 3-A Output, 2-MHz, Synchronous Step-Down Switcher With Integrated FETs

Check for Samples: [TPS54388-Q1](#)

FEATURES

- Qualified for Automotive Applications
- Two 12-m Ω (typical) MOSFETs for High Efficiency at 3-A Loads
- 200 kHz to 2 MHz Switching Frequency
- 0.8 V \pm 1% Voltage Reference Over Temperature (–40°C to 150°C)
- Synchronizes to External Clock
- Adjustable Slow Start/Sequencing
- UV and OV Power Good Output
- –40°C to 150°C Operating Junction Temperature Range
- Thermally Enhanced 3mm x 3mm 16-pin QFN
- Pin Compatible to TPS54418

APPLICATIONS

- Low-Voltage, High-Density Power Systems
- Point of Load Regulation for High Performance DSPs, FPGAs, ASICs and Microprocessors
- Broadband, Networking and Optical Communications Infrastructure

SIMPLIFIED SCHEMATIC

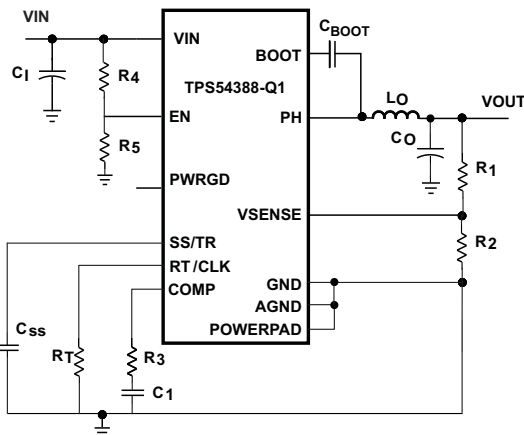

DESCRIPTION

The TPS54388-Q1 device is a full featured 6 V, 3 A, synchronous step down current mode converter with two integrated MOSFETs.

The TPS54388-Q1 enables small designs by integrating the MOSFETs, implementing current mode control to reduce external component count, reducing inductor size by enabling up to 2 MHz switching frequency, and minimizing the IC footprint with a small 3 mm x 3 mm thermally enhanced QFN package.

The TPS54388-Q1 provides accurate regulation for a variety of loads with an accurate \pm 1% Voltage Reference (VREF) over temperature.

Efficiency is maximized through the integrated 12 m Ω MOSFETs and 515 μ A typical supply current. Using the enable pin, shutdown supply current is reduced to 5.5 μ A by entering a shutdown mode.

Under voltage lockout is internally set at 2.45 V, but can be increased by programming the threshold with a resistor network on the enable pin. The output voltage startup ramp is controlled by the slow start pin. An open drain power good signal indicates the output is within 93% to 107% of its nominal voltage.

Frequency fold back and thermal shutdown protects the device during an over-current condition.

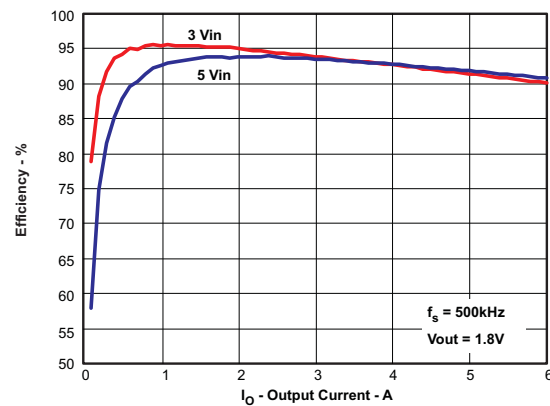

Please be aware that an important notice concerning availability, standard warranty, and use in critical applications of Texas Instruments semiconductor products and disclaimers thereto appears at the end of this data sheet.

PowerPAD is a trademark of Texas Instruments.

PRODUCTION DATA information is current as of publication date. Products conform to specifications per the terms of the Texas Instruments standard warranty. Production processing does not necessarily include testing of all parameters.

Copyright © 2010–2012, Texas Instruments Incorporated



These devices have limited built-in ESD protection. The leads should be shorted together or the device placed in conductive foam during storage or handling to prevent electrostatic damage to the MOS gates.

ORDERING INFORMATION

T _J	PACKAGE		ORDERABLE PART NUMBER	TOP-SIDE MARKING
-40°C to 150°C	QFN – RTE	Reel of 2500	TPS54388QRTERQ1	5438Q

ABSOLUTE MAXIMUM RATINGS⁽¹⁾

		VALUES		UNIT
		MIN	MAX	
Input voltage	VIN	-0.3	7	V
	EN	-0.3	3.3	
	BOOT		PH + 7	
	VSENSE	-0.3	3	
	COMP	-0.3	3	
	PWRGD	-0.3	7	
	SS/TR	-0.3	3	
	RT/CLK	-0.3	3.3	
Output voltage	BOOT-PH		7	V
	PH	-0.6	7	
	PH 10 ns Transient	-2	10	
Source current	EN		100	μA
	RT/CLK		100	μA
Sink current	COMP		100	μA
	PWRGD		10	mA
	SS/TR		100	μA
Temperature	T _j	-40	150	°C
	T _{stg}	-65	150	°C
	T _A	-40	125	°C

- (1) Stresses beyond those listed under *absolute maximum ratings* may cause permanent damage to the device. These are stress ratings only, and functional operation of the device at these or any other conditions beyond those indicated under ELECTRICAL SPECIFICATIONS is not implied. Exposure to absolute-maximum-rated conditions for extended periods may affect device reliability.

THERMAL INFORMATION

THERMAL METRIC ⁽¹⁾⁽²⁾⁽³⁾		TPS54388-Q1	UNITS
		(RTE)	
		(QFN-16) PINS	
θ_{JA}	Junction-to-ambient thermal resistance	56.4	°C/W
θ_{JA}	Junction-to-ambient thermal resistance ⁽⁴⁾	37	
ψ_{JT}	Junction-to-top characterization parameter	0.9	
ψ_{JB}	Junction-to-board characterization parameter	22.2	
$\theta_{JC(top)}$	Junction-to-case(top) thermal resistance	28.7	
$\theta_{JC(bottom)}$	Junction-to-case(bottom) thermal resistance	12.5	
θ_{JB}	Junction-to-board thermal resistance	22.7	

- (1) For more information about traditional and new thermal metrics, see the IC Package Thermal Metrics application report, [SPRA953](#).
- (2) Maximum power dissipation may be limited by overcurrent protection
- (3) Power rating at a specific ambient temperature T_A should be determined with a junction temperature of 150°C. This is the point where distortion starts to substantially increase. Thermal management of the PCB should strive to keep the junction temperature at or below 150°C for best performance and long-term reliability. See power dissipation estimate in application section of this data sheet for more information.
- (4) Test boards conditions:
 - (a) 2 inches x 2 inches, 4 layers, thickness: 0.062 inch
 - (b) 2 oz. copper traces located on the top of the PCB
 - (c) 2 oz. copper ground planes on the 2 internal layers and bottom layer
 - (d) 4 thermal vias (10mil) located under the device package

ELECTRICAL CHARACTERISTICS

$T_J = -40^{\circ}\text{C}$ to 150°C , $V_{IN} = 2.95$ to 6 V (unless otherwise noted)

DESCRIPTION	CONDITIONS	MIN	TYP	MAX	UNIT
SUPPLY VOLTAGE (VIN PIN)					
Operating input voltage		2.95		6.0	V
Internal under voltage lockout threshold	VIN UVLO START		2.28	2.5	V
	VIN UVLO STOP		2.45	2.6	V
Shutdown supply current	EN = 0 V, 25°C , $2.95\text{ V} \leq V_{IN} \leq 6\text{ V}$		5.5	15	μA
Quiescent Current - I_q	$V_{SENSE} = 0.9\text{ V}$, $V_{IN} = 5\text{ V}$, 25°C , $RT = 400\text{ k}\Omega$		515	750	μA
ENABLE AND UVLO (EN PIN)					
Enable threshold	Rising		1.25		V
	Falling		1.18		V
Input current	Enable threshold +50 mV		-1.6		μA
	Enable threshold -50 mV		-1.6		μA
VOLTAGE REFERENCE (VSENSE PIN)					
Voltage Reference	$2.95\text{ V} \leq V_{IN} \leq 6\text{ V}$, $-40^{\circ}\text{C} < T_J < 150^{\circ}\text{C}$	0.79	0.800	0.811	V
MOSFET					
High-side switch resistance	BOOT-PH = 5 V		12	30	$\text{m}\Omega$
	BOOT-PH = 2.95 V		16	30	$\text{m}\Omega$
Low-side switch resistance	VIN = 5 V		13	30	$\text{m}\Omega$
	VIN = 2.95 V		17	30	$\text{m}\Omega$
ERROR AMPLIFIER					
Input current			2		nA
Error amplifier transconductance (gm)	$-2\ \mu\text{A} < I_{(COMP)} < 2\ \mu\text{A}$, $V_{(COMP)} = 1\text{ V}$		245		μmhos
Error amplifier transconductance (gm) during slow start	$-2\ \mu\text{A} < I_{(COMP)} < 2\ \mu\text{A}$, $V_{(COMP)} = 1\text{ V}$, $V_{sense} = 0.4\text{ V}$		79		μmhos
Error amplifier source/sink	$V_{(COMP)} = 1\text{ V}$, 100 mV overdrive		± 20		μA
COMP to Iswitch gm			25		A/V
CURRENT LIMIT					
Current limit threshold		3.7	6.5		A
THERMAL SHUTDOWN					
Thermal Shutdown			168		$^{\circ}\text{C}$
Hysteresis			20		$^{\circ}\text{C}$
TIMING RESISTOR AND EXTERNAL CLOCK (RT/CLK PIN)					
Switching frequency range using RT mode		200		2000	kHz
Switching frequency	$R_t = 400\text{ k}\Omega$	400	500	600	kHz
Switching frequency range using CLK mode		300		2000	kHz
Minimum CLK pulse width		75			ns
RT/CLK voltage	$R_{(RT/CLK)} = 400\text{ k}\Omega$		0.5		V
RT/CLK high threshold			1.6	2.5	V
RT/CLK low threshold		0.4	0.6		V
RT/CLK falling edge to PH rising edge delay	Measure at 500 kHz with RT resistor in series		90		ns
PLL lock in time	Measure at 500 kHz		45		μs

ELECTRICAL CHARACTERISTICS (continued)
 $T_J = -40^{\circ}\text{C}$ to 150°C , $V_{IN} = 2.95$ to 6 V (unless otherwise noted)

DESCRIPTION	CONDITIONS	MIN	TYP	MAX	UNIT
PH (PH PIN)					
Minimum On time	Measured at 50% points on PH, $I_{OUT} = 3$ A		75		ns
	Measured at 50% points on PH, $V_{IN} = 6$ V, $I_{OUT} = 0$ A		120		
Minimum Off time	Prior to skipping off pulses, $BOOT-PH = 2.95$ V, $I_{OUT} = 3$ A		60		ns
Rise Time	$V_{IN} = 6$ V, 6 A		2.25		V/ns
Fall Time			2		
BOOT (BOOT PIN)					
BOOT Charge Resistance	$V_{IN} = 5$ V		16		Ω
BOOT-PH UVLO	$V_{IN} = 2.95$ V		2.1		V
SLOW START AND TRACKING (SS/TR PIN)					
Charge Current	$V_{(SS/TR)} = 0.4$ V		2		μA
SS/TR to VSENSE matching	$V_{(SS/TR)} = 0.4$ V		50		mV
SS/TR to reference crossover	98% normal		1.1		V
SS/TR discharge voltage (Overload)	$V_{SENSE} = 0$ V		61		mV
SS/TR discharge current (Overload)	$V_{SENSE} = 0$ V, $V_{(SS/TR)} = 0.4$ V		350		μA
SS discharge current (UVLO, EN, Thermal fault)	$V_{IN} = 5$ V, $V_{(SS)} = 0.5$ V		1.9		mA
POWER GOOD (PWRGD PIN)					
VSENSE threshold	VSENSE falling (Fault)		91		% Vref
	VSENSE rising (Good)		93		% Vref
	VSENSE rising (Fault)		109		% Vref
	VSENSE falling (Good)		107		% Vref
Hysteresis	VSENSE falling		2		% Vref
Output high leakage	$V_{SENSE} = V_{REF}$, $V_{(PWRGD)} = 5.5$ V		7		nA
On resistance			56	100	Ω
Output low	$I_{(PWRGD)} = 3$ mA		0.3		V
Minimum V_{IN} for valid output	$V_{(PWRGD)} < 0.5$ V at 100 μA		0.650	1.6	V

DEVICE INFORMATION

PIN CONFIGURATION

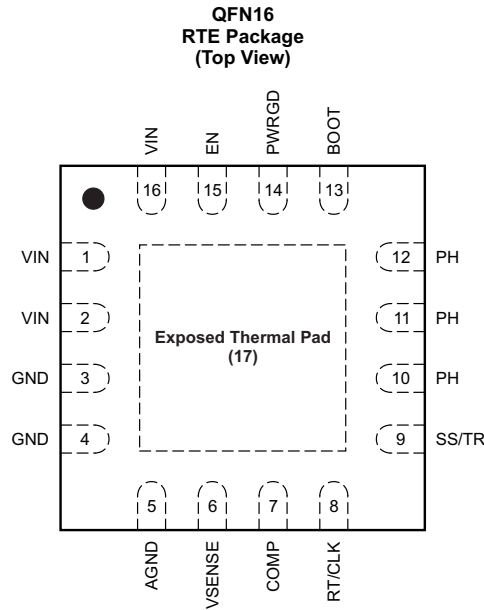

PIN FUNCTIONS

PIN		DESCRIPTION
NAME	NO.	
AGND	5	Analog Ground should be electrically connected to GND close to the device.
BOOT	13	A bootstrap capacitor is required between BOOT and PH. If the voltage on this capacitor is below the minimum required by the BOOT UVLO, the output is forced to switch off until the capacitor is refreshed.
COMP	7	Error amplifier output, and input to the output switch current comparator. Connect frequency compensation components to this pin.
EN	15	Enable pin, internal pull-up current source. Pull below 1.2 V to disable. Float to enable. Can be used to set the on/off threshold (adjust UVLO) with two additional resistors.
GND	3, 4	Power Ground. This pin should be electrically connected directly to the power pad under the IC.
PH	10, 11, 12	The source of the internal high side power MOSFET, and drain of the internal low side (synchronous) rectifier MOSFET.
PowerPAD™	17	GND pin should be connected to the exposed power pad for proper operation. This power pad should be connected to any internal PCB ground plane using multiple vias for good thermal performance.
PWRGD	14	An open drain output; asserts low if output voltage is low due to thermal shutdown, overcurrent, over/under-voltage or EN shut down.
RT/CLK	8	Resistor Timing or External Clock input pin.
SS/TR	9	Slow start and tracking. An external capacitor connected to this pin sets the output voltage rise time. This pin can also be used for tracking.
VIN	1, 2, 16	Input supply voltage, 2.95 V to 6 V.
VSENSE	6	Inverting node of the transconductance (gm) error amplifier.

FUNCTIONAL BLOCK DIAGRAM

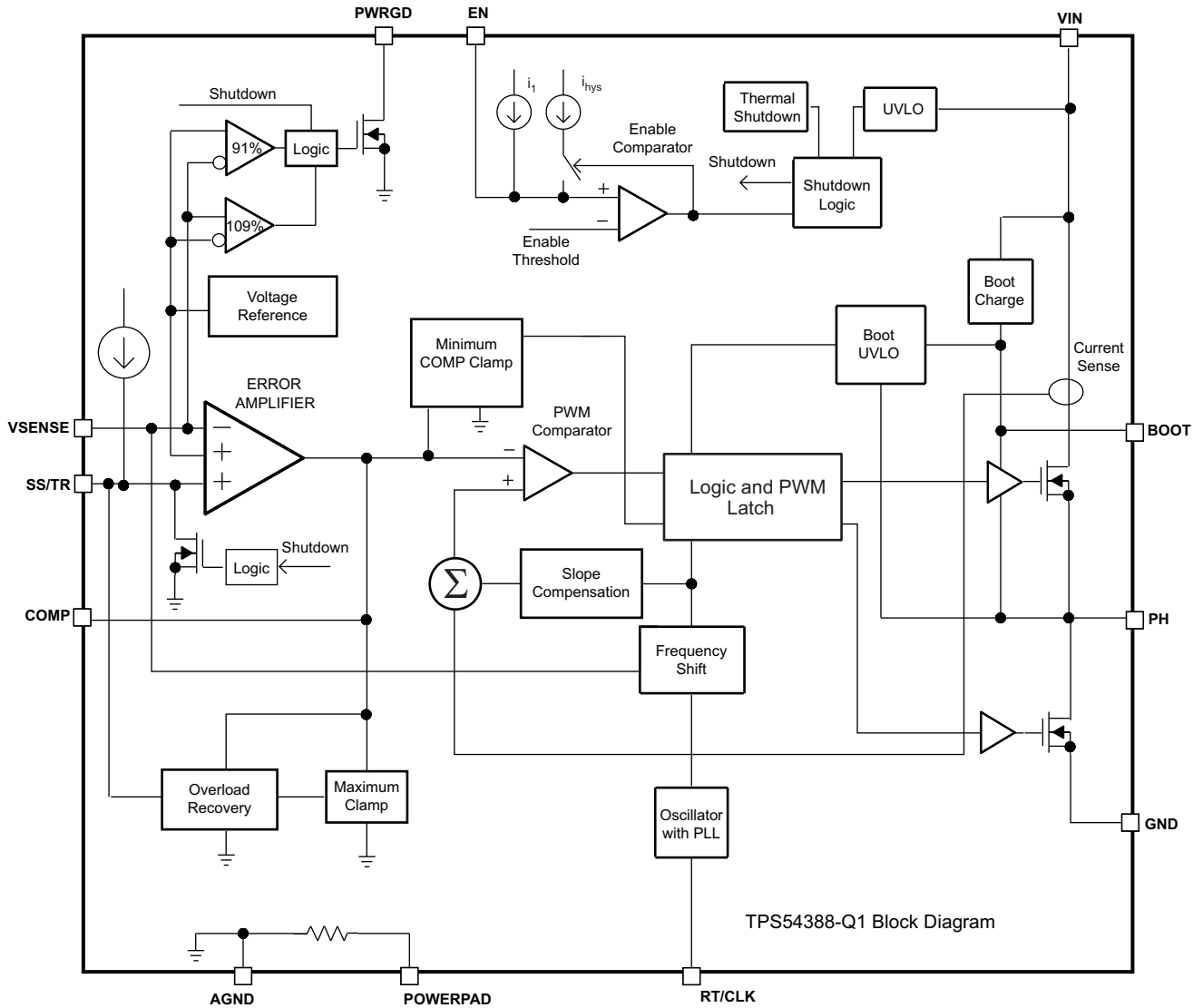

TYPICAL CHARACTERISTICS CURVES

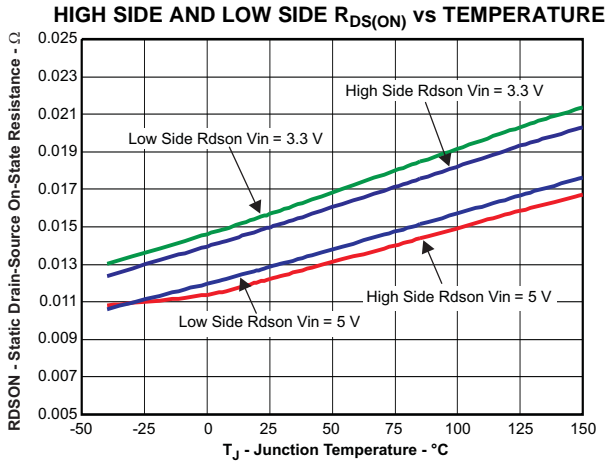

Figure 1.

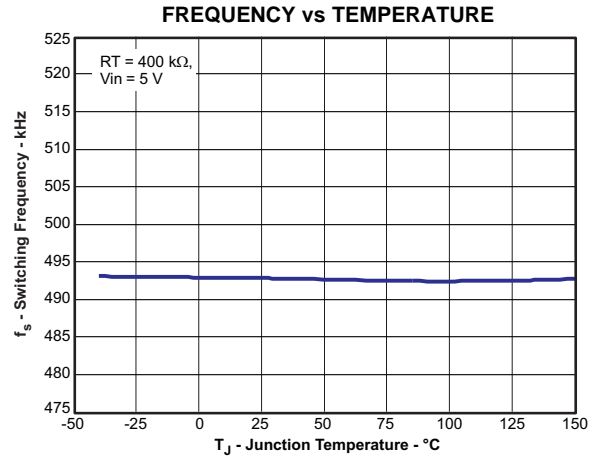

Figure 2.

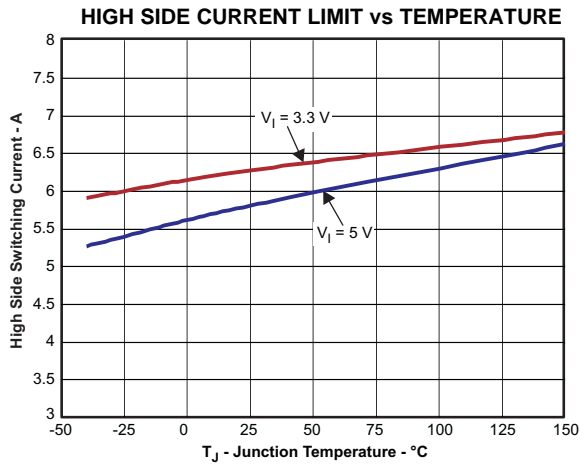

Figure 3.

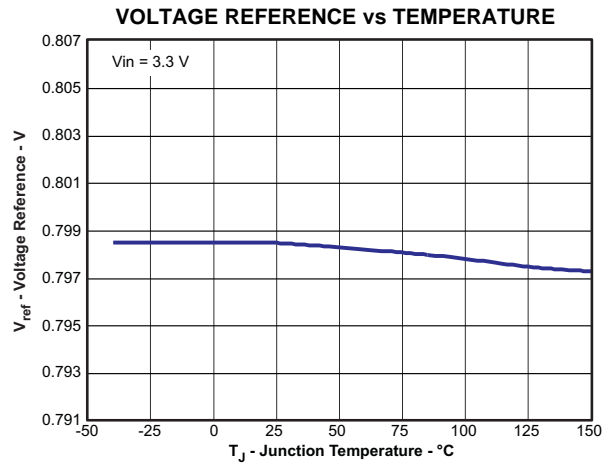

Figure 4.

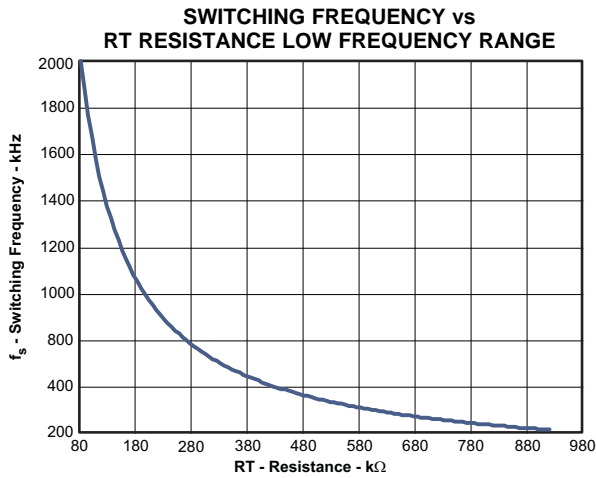

Figure 5.

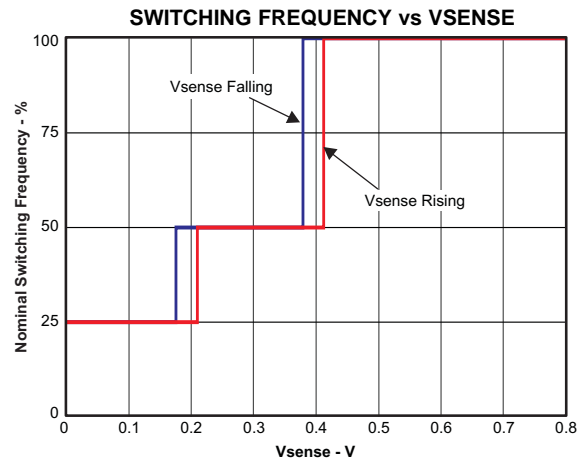

Figure 6.

TYPICAL CHARACTERISTICS CURVES (continued)

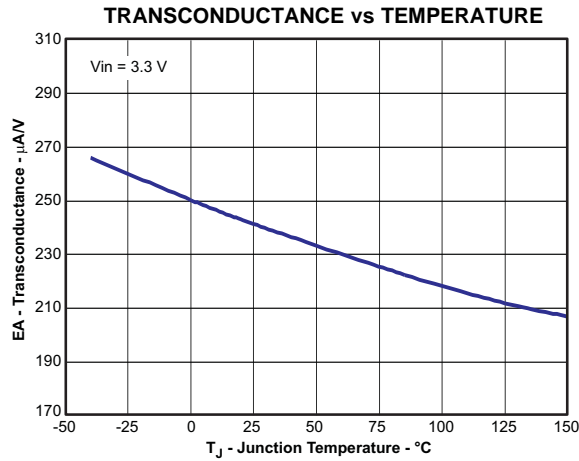

Figure 7.

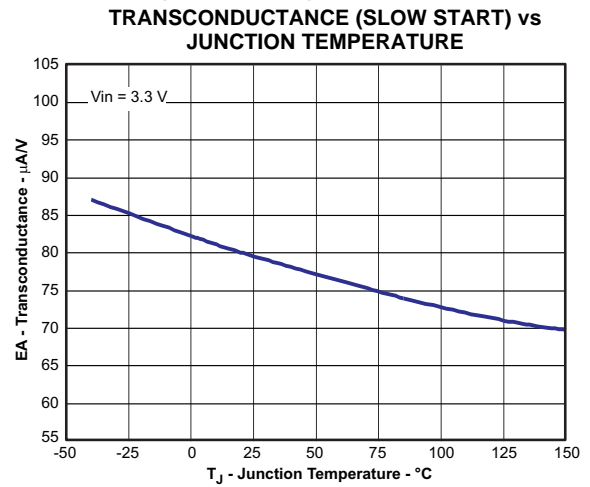

Figure 8.

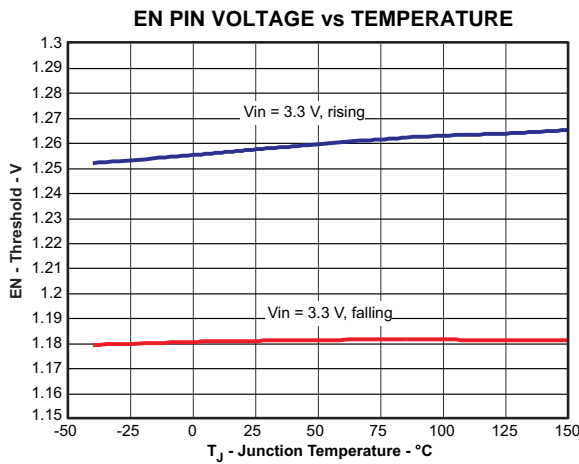

Figure 9.

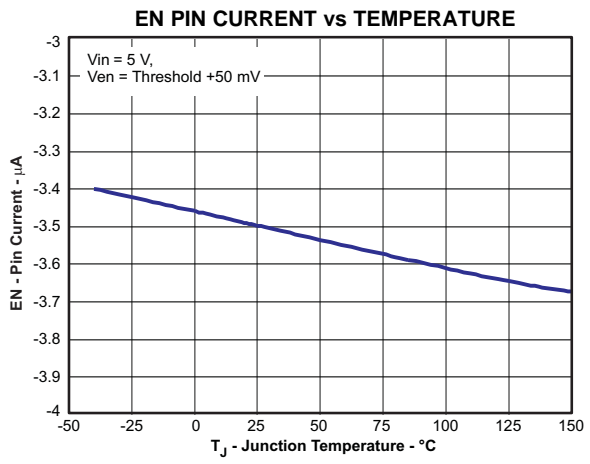

Figure 10.

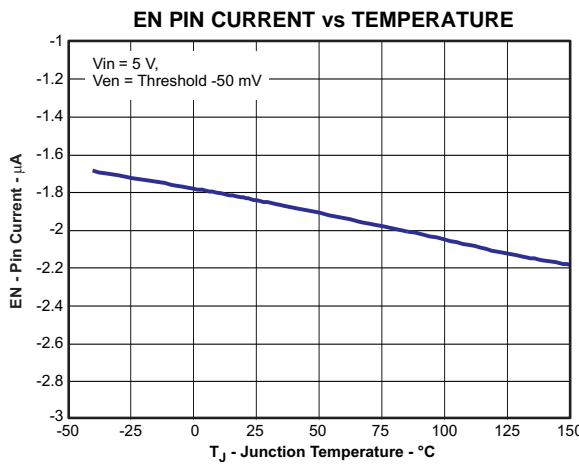

Figure 11.

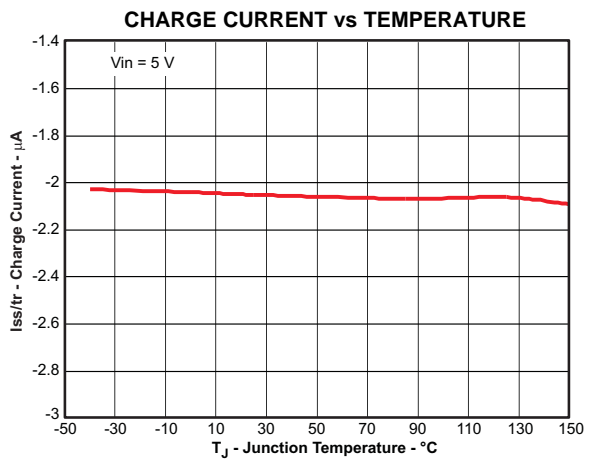

Figure 12.

TYPICAL CHARACTERISTICS CURVES (continued)

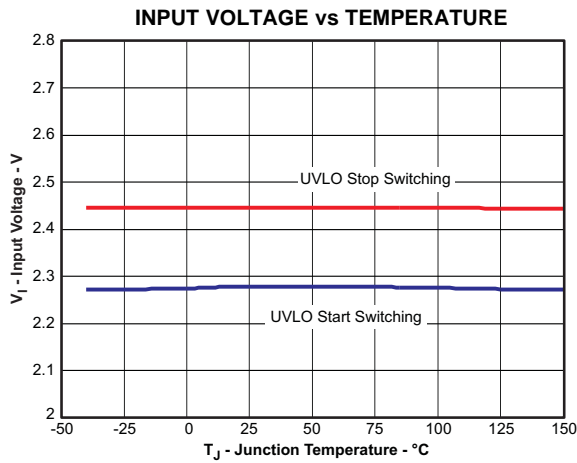

Figure 13.

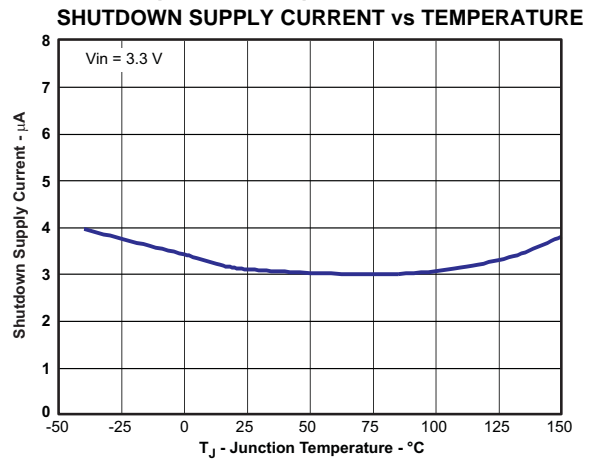

Figure 14.

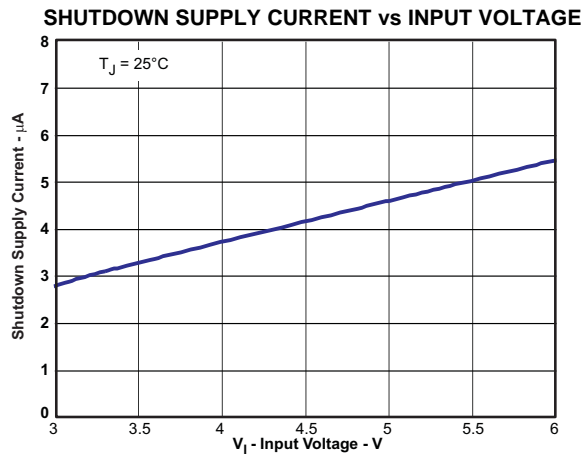

Figure 15.

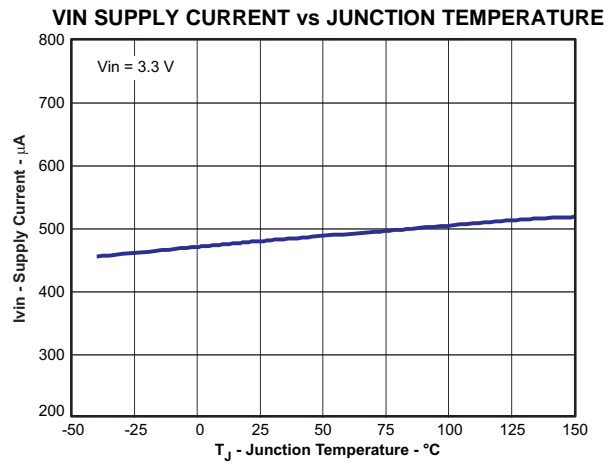

Figure 16.

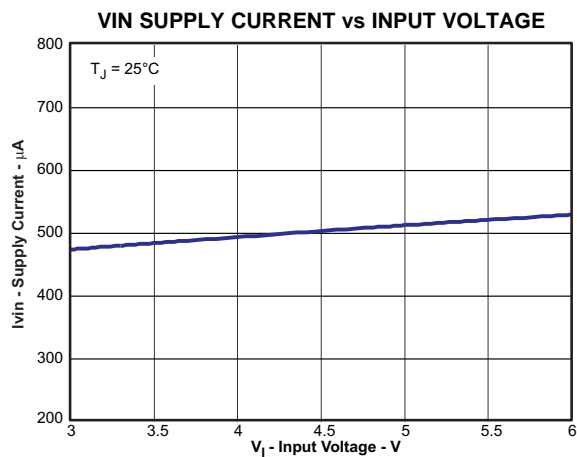

Figure 17.

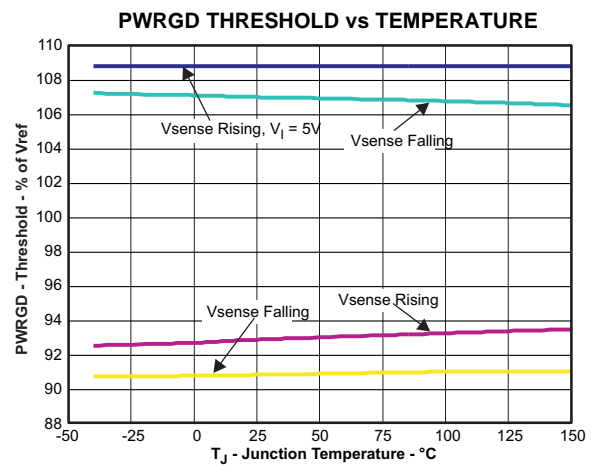

Figure 18.

TYPICAL CHARACTERISTICS CURVES (continued)

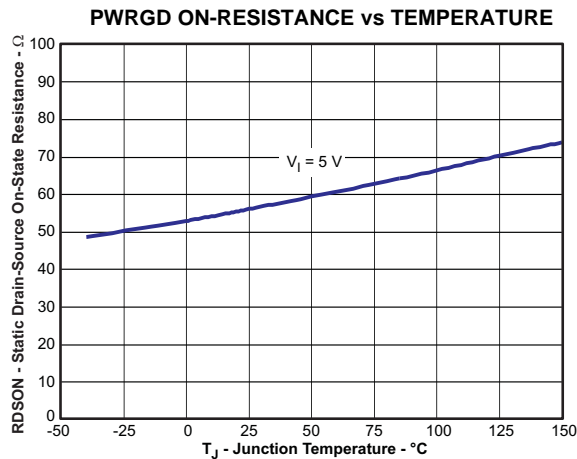

Figure 19.

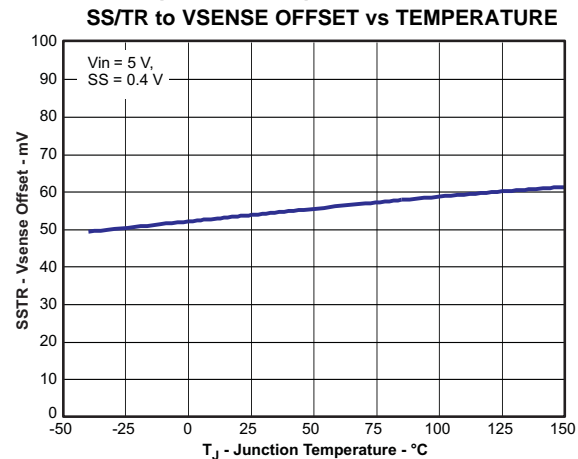

Figure 20.

OVERVIEW

The TPS54388-Q1 is a 6-V, 3-A, synchronous step-down (buck) converter with two integrated n-channel MOSFETs. To improve performance during line and load transients the device implements a constant frequency, peak current mode control which reduces output capacitance and simplifies external frequency compensation design. The wide switching frequency of 200 kHz to 2000 kHz allows for efficiency and size optimization when selecting the output filter components. The switching frequency is adjusted using a resistor to ground on the RT/CLK pin. The device has an internal phase lock loop (PLL) on the RT/CLK pin that is used to synchronize the power switch turn on to a falling edge of an external system clock.

The TPS54388-Q1 has a typical default start up voltage of 2.45 V. The EN pin has an internal pull-up current source that can be used to adjust the input voltage under voltage lockout (UVLO) with two external resistors. In addition, the pull up current provides a default condition when the EN pin is floating for the device to operate. The total operating current for the TPS54388-Q1 is typically 515 μA when not switching and under no load. When the device is disabled, the supply current is less than 5.5 μA.

The integrated 12 mΩ MOSFETs allow for high efficiency power supply designs with continuous output currents up to 3 amperes.

The TPS54388-Q1 reduces the external component count by integrating the boot recharge diode. The bias voltage for the integrated high side MOSFET is supplied by a capacitor between the BOOT and PH pins. The boot capacitor voltage is monitored by an UVLO circuit and turns off the high side MOSFET when the voltage falls below a preset threshold. This BOOT circuit allows the TPS54388-Q1 to operate approaching 100%. The output voltage can be stepped down to as low as the 0.800 V reference.

The TPS54388-Q1 has a power good comparator (PWRGD) with 2% hysteresis.

The TPS54388-Q1 minimizes excessive output overvoltage transients by taking advantage of the overvoltage power good comparator. When the regulated output voltage is greater than 109% of the nominal voltage, the overvoltage comparator is activated, and the high side MOSFET is turned off and masked from turning on until the output voltage is lower than 107%.

The SS/TR (slow start/tracking) pin is used to minimize inrush currents or provide power supply sequencing during power up. A small value capacitor should be coupled to the pin for slow start. The SS/TR pin is discharged before the output power up to ensure a repeatable restart after an overtemperature fault, UVLO fault or disabled condition.

The use of a frequency fold-back circuit reduces the switching frequency during startup and over current fault conditions to help limit the inductor current.

DETAILED DESCRIPTION

FIXED FREQUENCY PWM CONTROL

The TPS54388-Q1 uses an adjustable fixed frequency, peak current mode control. The output voltage is compared through external resistors on the VSENSE pin to an internal voltage reference by an error amplifier which drives the COMP pin. An internal oscillator initiates the turn on of the high side power switch. The error amplifier output is compared to the high side power switch current. When the power switch current reaches the COMP voltage level the high side power switch is turned off and the low side power switch is turned on. The COMP pin voltage increases and decreases as the output current increases and decreases. The device implements a current limit by clamping the COMP pin voltage to a maximum level and also implements a minimum clamp for improved transient response performance.

SLOPE COMPENSATION AND OUTPUT CURRENT

The TPS54388-Q1 adds a compensating ramp to the switch current signal. This slope compensation prevents sub-harmonic oscillations as duty cycle increases. The available peak inductor current remains constant over the full duty cycle range.

BOOTSTRAP VOLTAGE (BOOT) AND LOW DROPOUT OPERATION

The TPS54388-Q1 has an integrated boot regulator and requires a small ceramic capacitor between the BOOT and PH pin to provide the gate drive voltage for the high side MOSFET. The value of the ceramic capacitor should be 0.1 μ F. A ceramic capacitor with an X7R or X5R grade dielectric with a voltage rating of 10 V or higher is recommended because of the stable characteristics over temperature and voltage.

To improve drop out, the TPS54388-Q1 is designed to operate at 100% duty cycle as long as the BOOT to PH pin voltage is greater than 2.2 V. The high side MOSFET is turned off using an UVLO circuit, allowing for the low side MOSFET to conduct when the voltage from BOOT to PH drops below 2.2 V. Since the supply current sourced from the BOOT pin is low, the high side MOSFET can remain on for more switching cycles than are required to refresh the capacitor, thus the effective duty cycle of the switching regulator is high.

ERROR AMPLIFIER

The TPS54388-Q1 has a transconductance amplifier. The error amplifier compares the VSENSE voltage to the lower of the SS/TR pin voltage or the internal 0.800 V voltage reference. The transconductance of the error amplifier is 245 μ A/V during normal operation. When the voltage of VSENSE pin is below 0.800 V and the device is regulating using the SS/TR voltage, the gm is typically greater than 79 μ A/V, but less than 245 μ A/V. The frequency compensation components are placed between the COMP pin and ground.

VOLTAGE REFERENCE

The voltage reference system produces a precise $\pm 1\%$ voltage reference over temperature by scaling the output of a temperature-stable bandgap circuit. The bandgap and scaling circuits produce 0.800 V at the non-inverting input of the error amplifier.

ADJUSTING THE OUTPUT VOLTAGE

The output voltage is set with a resistor divider from the output node to the VSENSE pin. It is recommended to use divider resistors with 1% tolerance or better. Start with a 100 k Ω for the R1 resistor and use the [Equation 1](#) to calculate R2. To improve efficiency at light loads consider using larger value resistors. If the values are too high the regulator is more susceptible to noise and voltage errors from the VSENSE input current are noticeable.

$$R2 = R1 \times \left(\frac{0.799 \text{ V}}{V_O - 0.799 \text{ V}} \right) \quad (1)$$

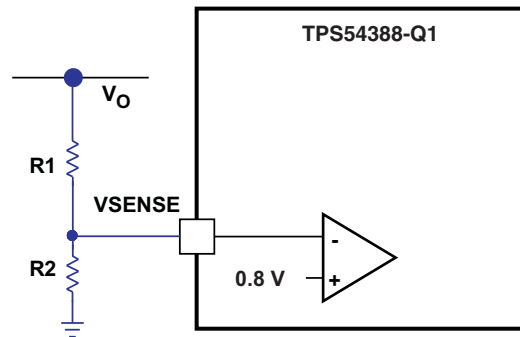

Figure 21. Voltage Divider Circuit

ENABLE AND ADJUSTING UNDER-VOLTAGE LOCKOUT

The TPS54388-Q1 is disabled when the VIN pin voltage falls below 2.6 V. If an application requires a higher under-voltage lockout (UVLO), use the EN pin as shown in Figure 22 to adjust the input voltage UVLO by using two external resistors. It is recommended to use the EN resistors to set the UVLO falling threshold (V_{STOP}) above 2.6 V. The rising threshold (V_{START}) should be set to provide enough hysteresis to allow for any input supply variations. The EN pin has an internal pull-up current source that provides the default condition of the TPS54388-Q1 operating when the EN pin floats. Once the EN pin voltage exceeds 1.25 V, an additional 1.6 μ A of hysteresis is added. When the EN pin is pulled below 1.18 V, the 1.6 μ A is removed. This additional current facilitates input voltage hysteresis.

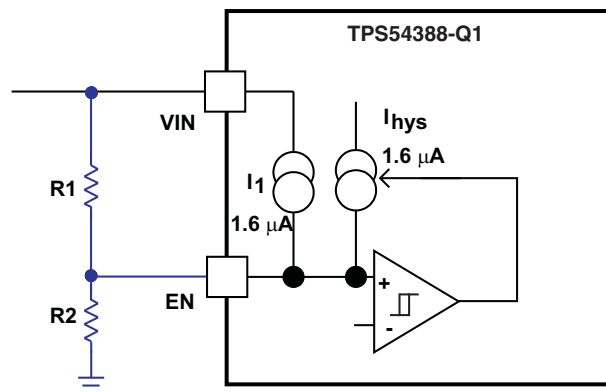

Figure 22. Adjustable Undervoltage Lock Out

$$R1 = \frac{V_{START} \left(\frac{V_{ENFALLING}}{V_{ENRISING}} \right) - V_{STOP}}{I_1 \left(1 - \frac{V_{ENFALLING}}{V_{ENRISING}} \right) + I_{hys}} \quad (2)$$

$$R2 = \frac{R1 \times V_{ENFALLING}}{V_{STOP} - V_{ENFALLING} + R1(I_1 + I_{hys})} \quad (3)$$

Where $I_{hys} = 1.6 \mu\text{A}$, $I_1 = 1.6 \mu\text{A}$, $V_{ENRISING} = 1.25 \text{ V}$, $V_{ENFALLING} = 1.18 \text{ V}$

SLOW START/TRACKING PIN

The TPS54388-Q1 regulates to the lower of the SS/TR pin and the internal reference voltage. A capacitor on the SS/TR pin to ground implements a slow start time. The TPS54388-Q1 has an internal pull-up current source of 2 μA which charges the external slow start capacitor. Equation 4 calculates the required slow start capacitor value where T_{ss} is the desired slow start time in ms, I_{ss} is the internal slow start charging current of 2 μA , and V_{ref} is the internal voltage reference of 0.800 V.

$$C_{ss}(\text{nF}) = \frac{T_{ss}(\text{mS}) \times I_{ss}(\mu\text{A})}{V_{ref}(\text{V})} \tag{4}$$

If during normal operation, the V_{IN} goes below the UVLO, EN pin pulled below 1.2 V, or a thermal shutdown event occurs, the TPS54388-Q1 stops switching. When the V_{IN} goes above UVLO, EN is released or pulled high, or a thermal shutdown is exited, then SS/TR is discharged to below 60 mV before reinitiating a powering up sequence. The VSENSE voltage will follow the SS/TR pin voltage with a 50 mV offset up to 85% of the internal voltage reference. When the SS/TR voltage is greater than 85% on the internal reference voltage the offset increases as the effective system reference transitions from the SS/TR voltage to the internal voltage reference.

SEQUENCING

Many of the common power supply sequencing methods can be implemented using the SS/TR, EN and PWRGD pins. The sequential method can be implemented using an open drain or collector output of a power on reset pin of another device. Figure 23 shows the sequential method. The power good is coupled to the EN pin on the TPS54388-Q1 which enables the second power supply once the primary supply reaches regulation.

Ratio-metric start up can be accomplished by connecting the SS/TR pins together. The regulator outputs ramp up and reach regulation at the same time. When calculating the slow start time the pull up current source must be doubled in Equation 4. The ratio metric method is illustrated in Figure 25.

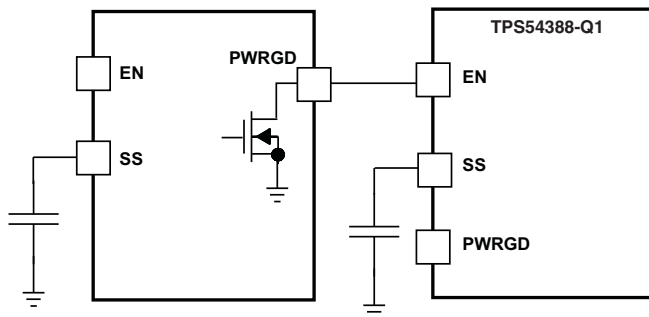

Figure 23. Sequential Start-Up Sequence

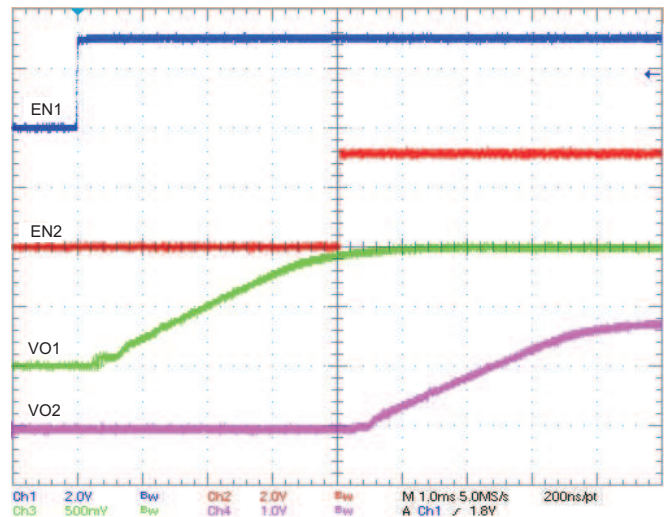

Figure 24. Sequential Startup using EN and PWRGD

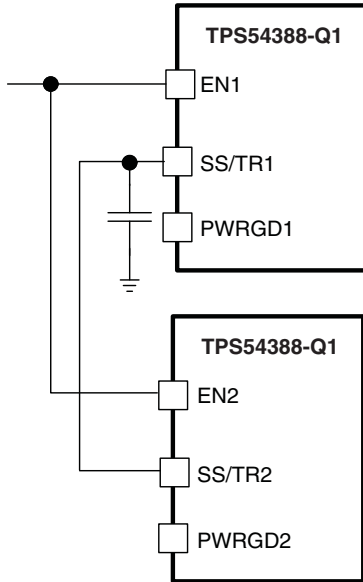

Figure 25. Schematic for Ratiometric Start-Up Sequence

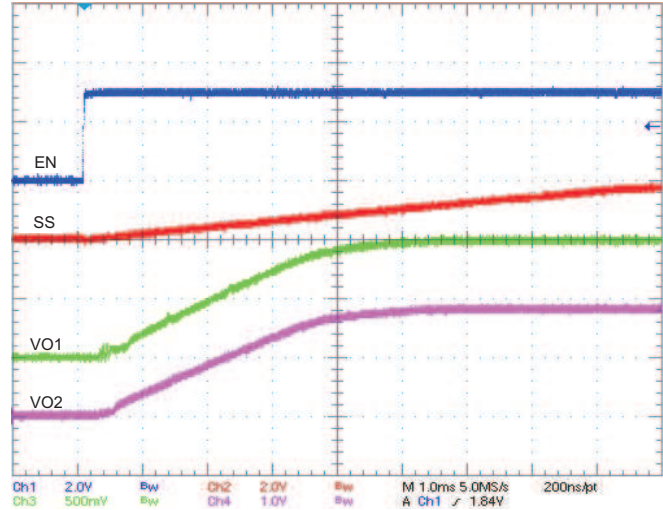

Figure 26. Ratio-metric Startup with Vout1 Leading Vout2

Ratio-metric and simultaneous power supply sequencing can be implemented by connecting the resistor network of R1 and R2 shown in Figure 27 to the output of the power supply that needs to be tracked or another voltage reference source. Using Equation 5 and Equation 6, the tracking resistors can be calculated to initiate the Vout2 slightly before, after or at the same time as Vout1. Equation 7 is the voltage difference between Vout1 and Vout2. The ΔV variable is zero volts for simultaneous sequencing. To minimize the effect of the inherent SS/TR to VSENSE offset ($V_{ssoffset}$) in the slow start circuit and the offset created by the pullup current source (I_{ss}) and tracking resistors, the $V_{ssoffset}$ and I_{ss} are included as variables in the equations. To design a ratio-metric start up in which the Vout2 voltage is slightly greater than the Vout1 voltage when Vout2 reaches regulation, use a negative number in Equation 5 through Equation 7 for ΔV . Equation 7 will result in a positive number for applications which the Vout2 is slightly lower than Vout1 when Vout2 regulation is achieved. Since the SS/TR pin must be pulled below 60mV before starting after an EN, UVLO or thermal shutdown fault, careful selection of the tracking resistors is needed to ensure the device will restart after a fault. Make sure the calculated R1 value from Equation 5 is greater than the value calculated in Equation 8 to ensure the device can recover from a fault. As the SS/TR voltage becomes more than 85% of the nominal reference voltage the $V_{ssoffset}$ becomes larger as the slow start circuits gradually handoff the regulation reference to the internal voltage reference. The SS/TR pin voltage needs to be greater than 1.1 V for a complete handoff to the internal voltage reference as shown in Figure 26.

$$R1 = \frac{V_{out2} + \Delta V}{V_{ref}} \times \frac{V_{ssoffset}}{I_{ss}} \quad (5)$$

$$R2 = \frac{V_{ref} \times R1}{V_{out2} + \Delta V - V_{ref}} \quad (6)$$

$$\Delta V = V_{out1} - V_{out2} \quad (7)$$

$$R1 > 2930 \times V_{out1} - 145 \times \Delta V \quad (8)$$

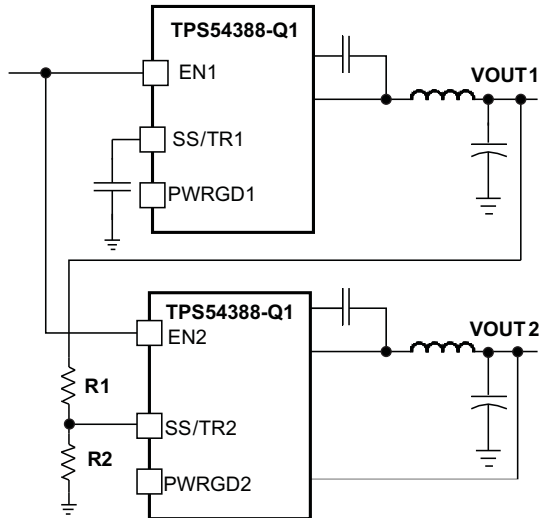

Figure 27. Ratio-metric and Simultaneous Startup Sequence

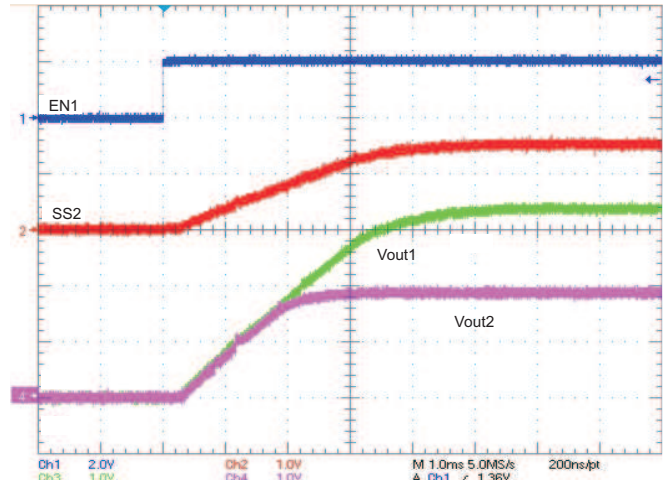

Figure 28. Ratio-metric Start-Up using Coupled SS/TR Pins

CONSTANT SWITCHING FREQUENCY and TIMING RESISTOR (RT/CLK Pin)

The switching frequency of the TPS54388-Q1 is adjustable over a wide range from 200 kHz to 2000 kHz by placing a maximum of 700 kΩ and minimum of 85 kΩ, respectively, on the RT/CLK pin. An internal amplifier holds this pin at a fixed voltage when using an external resistor to ground to set the switching frequency. The RT/CLK is typically 0.5 V. To determine the timing resistance for a given switching frequency, use the curve in Figure 5 or Equation 9.

$$RT (k\Omega) = \frac{247530}{Fsw(kHz)^{1.0533}} \tag{9}$$

$$Fsw(kHz) = \frac{131904}{RT(k\Omega)^{0.9492}} \tag{10}$$

To reduce the solution size one would typically set the switching frequency as high as possible, but tradeoffs of the efficiency, maximum input voltage and minimum controllable on time should be considered.

The minimum controllable on time is typically 60 ns at full current load and 120 ns at no load, and limits the maximum operating input voltage or output voltage.

OVERCURRENT PROTECTION

The TPS54388-Q1 implements a cycle by cycle current limit. During each switching cycle the high side switch current is compared to the voltage on the COMP pin. When the instantaneous switch current intersects the COMP voltage, the high side switch is turned off. During overcurrent conditions that pull the output voltage low, the error amplifier responds by driving the COMP pin high, increasing the switch current. The error amplifier output is clamped internally. This clamp functions as a switch current limit.

FREQUENCY SHIFT

To operate at high switching frequencies and provide protection during overcurrent conditions, the TPS54388-Q1 implements a frequency shift. If frequency shift was not implemented, during an overcurrent condition the low side MOSFET may not be turned off long enough to reduce the current in the inductor, causing a current runaway. With frequency shift, during an overcurrent condition the switching frequency is reduced from 100%, then 50%, then 25%, as the voltage decreases from 0.800 to 0 volts on VSENSE pin to allow the low side MOSFET to be off long enough to decrease the current in the inductor. During start-up, the switching frequency increases as the voltage on VSENSE increases from 0 to 0.800 volts. See Figure 6 for details.

REVERSE OVERCURRENT PROTECTION

The TPS54388-Q1 implements low side current protection by detecting the voltage across the low side MOSFET. When the converter sinks current through its low side FET, the control circuit turns off the low side MOSFET if the reverse current is typically more than 4.5 A. By implementing this additional protection scheme, the converter is able to protect itself from excessive current during power cycling and start-up into pre-biased outputs.

SYNCHRONIZE USING THE RT/CLK PIN

The RT/CLK pin is used to synchronize the converter to an external system clock. See Figure 29. To implement the synchronization feature in a system, connect a square wave to the RT/CLK pin with an on time of at least 75ns. If the pin is pulled above the PLL upper threshold, a mode change occurs and the pin becomes a synchronization input. The internal amplifier is disabled and the pin is a high impedance clock input to the internal PLL. If clocking edges stop, the internal amplifier is re-enabled and the mode returns to the frequency set by the resistor. The square wave amplitude at this pin must transition lower than 0.6 V and higher than 1.6 V typically. The synchronization frequency range is 300 kHz to 2000 kHz. The rising edge of the PH is synchronized to the falling edge of RT/CLK pin.

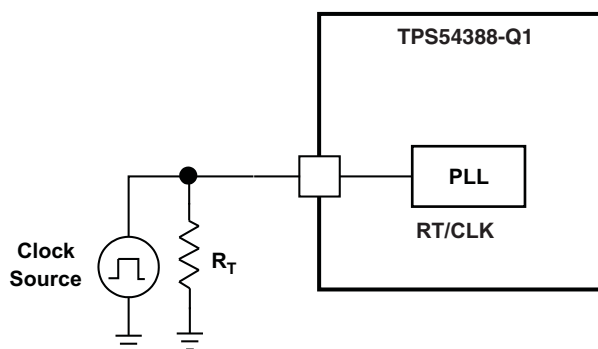

Figure 29. Synchronizing to a System Clock

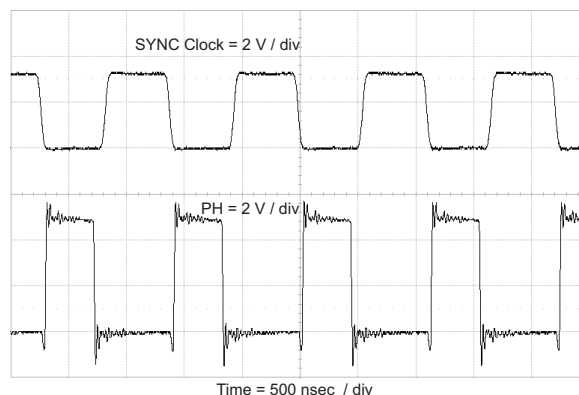

Figure 30. Plot of Synchronizing to System Clock

POWER GOOD (PWRGD PIN)

The PWRGD pin output is an open drain MOSFET. The output is pulled low when the VSENSE voltage enters the fault condition by falling below 91% or rising above 109% of the nominal internal reference voltage. There is a 2% hysteresis on the threshold voltage, so when the VSENSE voltage rises to the good condition above 93% or falls below 107% of the internal voltage reference the PWRGD output MOSFET is turned off. It is recommended to use a pull-up resistor between the values of 1k Ω and 100k Ω to a voltage source that is 6 V or less. The PWRGD is in a valid state once the VIN input voltage is greater than 1.1 V.

OVERVOLTAGE TRANSIENT PROTECTION

The TPS54388-Q1 incorporates an overvoltage transient protection (OVTP) circuit to minimize voltage overshoot when recovering from output fault conditions or strong unload transients. The OVTP feature minimizes the output overshoot by implementing a circuit to compare the VSENSE pin voltage to the OVTP threshold which is 109% of the internal voltage reference. If the VSENSE pin voltage is greater than the OVTP threshold, the high side MOSFET is disabled preventing current from flowing to the output and minimizing output overshoot. When the VSENSE voltage drops lower than the OVTP threshold the high side MOSFET is allowed to turn on the next clock cycle.

THERMAL SHUTDOWN

The device implements an internal thermal shutdown to protect itself if the junction temperature exceeds 168°C. The thermal shutdown forces the device to stop switching when the junction temperature exceeds the thermal trip threshold. Once the die temperature decreases below 148°C, the device reinitiates the power up sequence by discharging the SS pin to below 60 mV. The thermal shutdown hysteresis is 20°C.

SMALL SIGNAL MODEL FOR LOOP RESPONSE

Figure 31 shows an equivalent model for the TPS54388-Q1 control loop which can be modeled in a circuit simulation program to check frequency response and dynamic load response. The error amplifier is a transconductance amplifier with a g_m of $245 \mu\text{A/V}$. The error amplifier can be modeled using an ideal voltage controlled current source. The resistor R_0 and capacitor C_0 model the open loop gain and frequency response of the amplifier. The 1-mV AC voltage source between the nodes a and b effectively breaks the control loop for the frequency response measurements. Plotting a/c shows the small signal response of the frequency compensation. Plotting a/b shows the small signal response of the overall loop. The dynamic loop response can be checked by replacing the R_L with a current source with the appropriate load step amplitude and step rate in a time domain analysis.

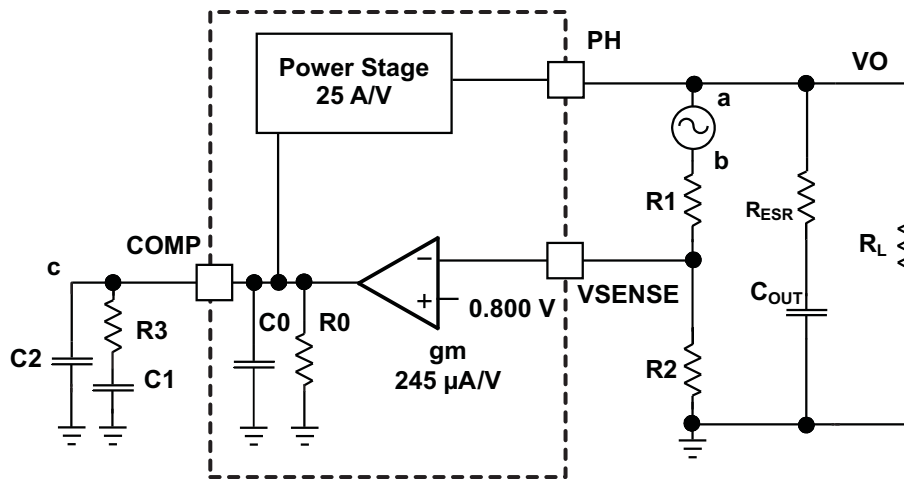

Figure 31. Small Signal Model for Loop Response

SIMPLE SMALL SIGNAL MODEL FOR PEAK CURRENT MODE CONTROL

Figure 31 is a simple small signal model that can be used to understand how to design the frequency compensation. The TPS54388-Q1 power stage can be approximated to a voltage controlled current source (duty cycle modulator) supplying current to the output capacitor and load resistor. The control to output transfer function is shown in Equation 11 and consists of a dc gain, one dominant pole and one ESR zero. The quotient of the change in switch current and the change in COMP pin voltage (node c in Figure 31) is the power stage transconductance. The g_m for the TPS54388-Q1 is 25 A/V . The low frequency gain of the power stage frequency response is the product of the transconductance and the load resistance as shown in Equation 12. As the load current increases and decreases, the low frequency gain decreases and increases, respectively. This variation with load may seem problematic at first glance, but the dominant pole moves with load current [see Equation 13]. The combined effect is highlighted by the dashed line in the right half of Figure 32. As the load current decreases, the gain increases and the pole frequency lowers, keeping the 0-dB crossover frequency the same for the varying load conditions which makes it easier to design the frequency compensation.

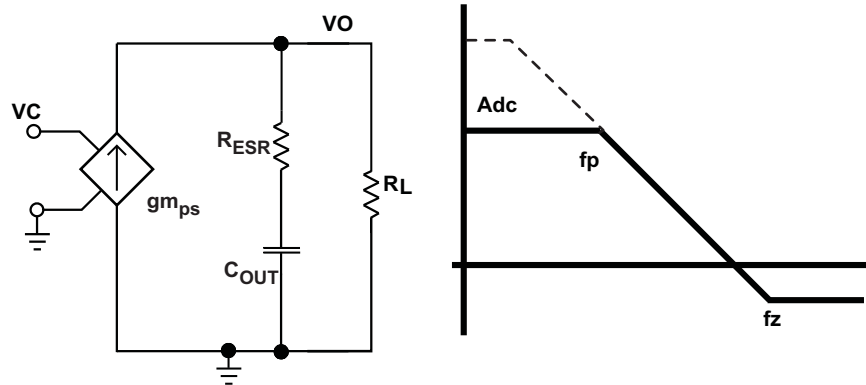

Figure 32. Simple Small Signal Model and Frequency Response for Peak Current Mode Control

$$\frac{v_o}{v_c} = A_{dc} \times \frac{\left(1 + \frac{s}{2\pi \times f_z}\right)}{\left(1 + \frac{s}{2\pi \times f_p}\right)} \quad (11)$$

$$A_{dc} = g_{m_{ps}} \times R_L \quad (12)$$

$$f_p = \frac{1}{C_{OUT} \times R_L \times 2\pi} \quad (13)$$

$$f_z = \frac{1}{C_{OUT} \times R_{ESR} \times 2\pi} \quad (14)$$

SMALL SIGNAL MODEL FOR FREQUENCY COMPENSATION

The TPS54388-Q1 uses a transconductance amplifier for the error amplifier and readily supports two of the commonly used frequency compensation circuits. The compensation circuits are shown in Figure 33. The Type 2 circuits are most likely implemented in high bandwidth power supply designs using low ESR output capacitors. In Type 2A, one additional high frequency pole is added to attenuate high frequency noise.

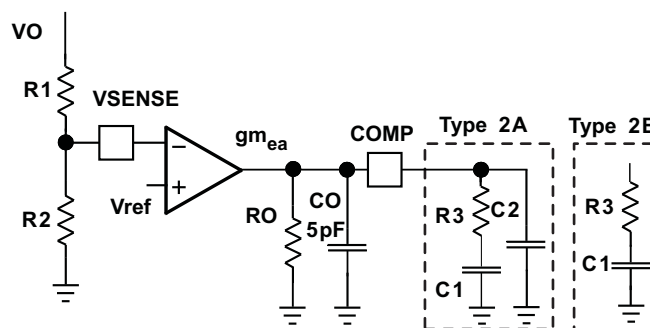

Figure 33. Types of Frequency Compensation

The design guidelines for TPS54388-Q1 loop compensation are as follows:

1. The modulator pole, $f_{p\text{ mod}}$, and the esr zero, $f_{z\text{ mod}}$ must be calculated using [Equation 15](#) and [Equation 16](#). Derating the output capacitor (C_{OUT}) may be needed if the output voltage is a high percentage of the capacitor rating. Use the capacitor manufacturer information to derate the capacitor value. Use [Equation 17](#) and [Equation 18](#) to estimate a starting point for the crossover frequency, f_c . [Equation 17](#) is the geometric mean of the modulator pole and the esr zero and [Equation 18](#) is the mean of modulator pole and the switching frequency. Use the lower value of [Equation 17](#) or [Equation 18](#) as the maximum crossover frequency.

$$f_{p\text{ mod}} = \frac{I_{\text{out max}}}{2\pi \times V_{\text{out}} \times C_{\text{out}}} \quad (15)$$

$$f_{z\text{ mod}} = \frac{1}{2\pi \times R_{\text{esr}} \times C_{\text{out}}} \quad (16)$$

$$f_c = \sqrt{f_{p\text{ mod}} \times f_{z\text{ mod}}} \quad (17)$$

$$f_c = \sqrt{f_{p\text{ mod}} \times \frac{f_{\text{sw}}}{2}} \quad (18)$$

2. R_3 can be determined by

$$R_3 = \frac{2\pi \times f_c \times V_o \times C_{\text{OUT}}}{g_{m_{\text{ea}}} \times V_{\text{ref}} \times g_{m_{\text{ps}}}} \quad (19)$$

Where $g_{m_{\text{ea}}}$ is the amplifier gain (245 $\mu\text{A/V}$), $g_{m_{\text{ps}}}$ is the power stage gain (25 A/V).

3. Place a compensation zero at the dominant pole $f_p = \frac{1}{C_{\text{OUT}} \times R_L \times 2\pi}$. C_1 can be determined by

$$C_1 = \frac{R_L \times C_{\text{OUT}}}{R_3} \quad (20)$$

4. C_2 is optional. It can be used to cancel the zero from C_o 's ESR.

$$C_2 = \frac{R_{\text{esr}} \times C_{\text{OUT}}}{R_3} \quad (21)$$

APPLICATION INFORMATION

DESIGN GUIDE – STEP-BY-STEP DESIGN PROCEDURE

This example details the design of a high frequency switching regulator design using ceramic output capacitors. This design is available as the HPA375 evaluation module (EVM). A few parameters must be known in order to start the design process. These parameters are typically determined on the system level. For this example, we start with the following known parameters:

Output Voltage	1.8 V
Transient Response 1 to 2A load step	$\Delta V_{out} = 5\%$
Maximum Output Current	3 A
Input Voltage	5 V nom. 3 V to 5 V
Output Voltage Ripple	< 30 mV p-p
Switching Frequency (Fsw)	1000 kHz

SELECTING THE SWITCHING FREQUENCY

The first step is to decide on a switching frequency for the regulator. Typically, you want to choose the highest switching frequency possible since this produces the smallest solution size. The high switching frequency allows for lower valued inductors and smaller output capacitors compared to a power supply that switches at a lower frequency. However, the highest switching frequency causes extra switching losses, which hurt the converter's performance. The converter is capable of running from 200 kHz to 2 MHz. Unless a small solution size is an ultimate goal, a moderate switching frequency of 1MHz is selected to achieve both a small solution size and a high efficiency operation. Using Equation 9, R5 is calculated to be 180 k Ω . A standard 1% 182 k Ω value was chosen in the design.

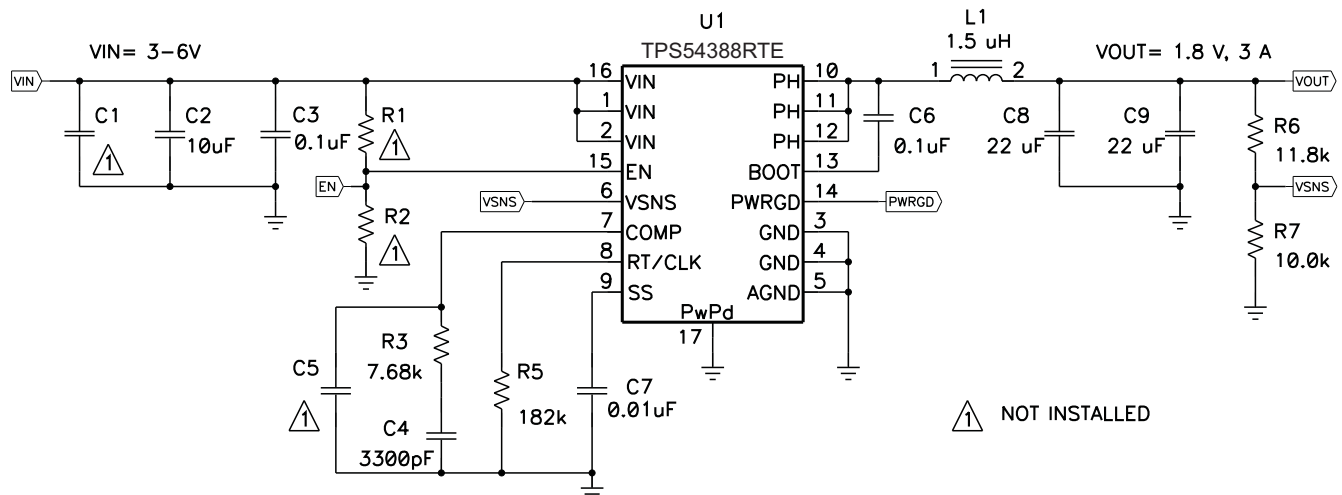

Figure 34. High Frequency, 1.8 V Output Power Supply Design with Adjusted UVLO

OUTPUT INDUCTOR SELECTION

The inductor selected works for the entire TPS54388-Q1 input voltage range. To calculate the value of the output inductor, use Equation 22. K_{IND} is a coefficient that represents the amount of inductor ripple current relative to the maximum output current. The inductor ripple current is filtered by the output capacitor. Therefore, choosing high inductor ripple currents impacts the selection of the output capacitor since the output capacitor must have a ripple current rating equal to or greater than the inductor ripple current. In general, the inductor ripple value is at the discretion of the designer; however, K_{IND} is normally from 0.1 to 0.3 for the majority of applications.

For this design example, use $K_{IND} = 0.3$ and the inductor value is calculated to be $1.36 \mu\text{H}$. For this design, a nearest standard value was chosen: $1.5 \mu\text{H}$. For the output filter inductor, it is important that the RMS current and saturation current ratings not be exceeded. The RMS and peak inductor current can be found from [Equation 24](#) and [Equation 25](#).

For this design, the RMS inductor current is 3.01 A and the peak inductor current is 3.72 A. The chosen inductor is a Coilcraft XLA4020-152ME_. It has a saturation current rating of 9.6 A and a RMS current rating of 7.5 A.

The current flowing through the inductor is the inductor ripple current plus the output current. During power up, faults or transient load conditions, the inductor current can increase above the calculated peak inductor current level calculated above. In transient conditions, the inductor current can increase up to the switch current limit of the device. For this reason, the most conservative approach is to specify an inductor with a saturation current rating equal to or greater than the switch current limit rather than the peak inductor current.

$$L1 = \frac{V_{inmax} - V_{out}}{I_o \times K_{IND}} \times \frac{V_{out}}{V_{inmax} \times f_{sw}} \quad (22)$$

$$I_{ripple} = \frac{V_{inmax} - V_{out}}{L1} \times \frac{V_{out}}{V_{inmax} \times f_{sw}} \quad (23)$$

$$I_{Lrms} = \sqrt{I_o^2 + \frac{1}{12} \times \left(\frac{V_o \times (V_{inmax} - V_o)}{V_{inmax} \times L1 \times f_{sw}} \right)^2} \quad (24)$$

$$I_{Lpeak} = I_{out} + \frac{I_{ripple}}{2} \quad (25)$$

OUTPUT CAPACITOR

There are three primary considerations for selecting the value of the output capacitor. The output capacitor determines the modulator pole, the output voltage ripple, and how the regulator responds to a large change in load current. The output capacitance needs to be selected based on the more stringent of these three criteria.

The desired response to a large change in the load current is the first criteria. The output capacitor needs to supply the load with current when the regulator can not. This situation would occur if there are desired hold-up times for the regulator where the output capacitor must hold the output voltage above a certain level for a specified amount of time after the input power is removed. The regulator is temporarily not able to supply sufficient output current if there is a large, fast increase in the current needs of the load such as transitioning from no load to a full load. The regulator usually needs two or more clock cycles for the control loop to see the change in load current and output voltage and adjust the duty cycle to react to the change. The output capacitor must be sized to supply the extra current to the load until the control loop responds to the load change. The output capacitance must be large enough to supply the difference in current for 2 clock cycles while only allowing a tolerable amount of droop in the output voltage. [Equation 26](#) shows the minimum output capacitance necessary to accomplish this.

For this example, the transient load response is specified as a 5 % change in V_{out} for a load step from 0 A (no load) to 1.5 A (50% load). For this example, $\Delta I_{out} = 1.5 - 0 = 1.5 \text{ A}$ and $\Delta V_{out} = 0.05 \times 1.8 = 0.090 \text{ V}$. Using these numbers gives a minimum capacitance of $33 \mu\text{F}$. This value does not take the ESR of the output capacitor into account in the output voltage change. For ceramic capacitors, the ESR is usually small enough to ignore in this calculation.

[Equation 27](#) calculates the minimum output capacitance needed to meet the output voltage ripple specification. Where f_{sw} is the switching frequency, V_{ripple} is the maximum allowable output voltage ripple, and I_{ripple} is the inductor ripple current. In this case, the maximum output voltage ripple is 30 mV. Under this requirement, [Equation 27](#) yields $2.3 \mu\text{F}$.

$$C_o > \frac{2 \times \Delta I_{out}}{f_{sw} \times \Delta V_{out}} \quad (26)$$

$$C_o > \frac{1}{8 \times f_{sw}} \times \frac{1}{\frac{V_{oripple}}{I_{ripple}}}$$

Where ΔI_{out} is the change in output current, f_{sw} is the regulators switching frequency and ΔV_{out} is the allowable change in the output voltage. (27)

Equation 28 calculates the maximum ESR an output capacitor can have to meet the output voltage ripple specification. Equation 28 indicates the ESR should be less than 55 mΩ. In this case, the ESR of the ceramic capacitor is much less than 55 mΩ.

Additional capacitance de-ratings for aging, temperature and DC bias should be factored in which increases this minimum value. For this example, two 22 μF 10 V X5R ceramic capacitors with 3 mΩ of ESR are used.

Capacitors generally have limits to the amount of ripple current they can handle without failing or producing excess heat. An output capacitor that can support the inductor ripple current must be specified. Some capacitor data sheets specify the RMS (Root Mean Square) value of the maximum ripple current. Equation 29 can be used to calculate the RMS ripple current the output capacitor needs to support. For this application, Equation 29 yields 333 mA.

$$Resr < \frac{V_{oripple}}{I_{ripple}} \quad (28)$$

$$I_{corms} = \frac{V_{out} \times (V_{inmax} - V_{out})}{\sqrt{12} \times V_{inmax} \times L1 \times f_{sw}} \quad (29)$$

INPUT CAPACITOR

The TPS54388-Q1 requires a high quality ceramic, type X5R or X7R, input decoupling capacitor of at least 4.7 μF of effective capacitance and in some applications a bulk capacitance. The effective capacitance includes any DC bias effects. The voltage rating of the input capacitor must be greater than the maximum input voltage. The capacitor must also have a ripple current rating greater than the maximum input current ripple of the TPS54388-Q1. The input ripple current can be calculated using Equation 30.

The value of a ceramic capacitor varies significantly over temperature and the amount of DC bias applied to the capacitor. The capacitance variations due to temperature can be minimized by selecting a dielectric material that is stable over temperature. X5R and X7R ceramic dielectrics are usually selected for power regulator capacitors because they have a high capacitance to volume ratio and are fairly stable over temperature. The output capacitor must also be selected with the DC bias taken into account. The capacitance value of a capacitor decreases as the DC bias across a capacitor increases.

For this example design, a ceramic capacitor with at least a 10 V voltage rating is required to support the maximum input voltage. For this example, one 10 μF and one 0.1 μF 10 V capacitors in parallel have been selected. The input capacitance value determines the input ripple voltage of the regulator. The input voltage ripple can be calculated using Equation 31. Using the design example values, $I_{outmax}=3$ A, $C_{in}=10$ μF, $f_{sw}=1$ MHz, yields an input voltage ripple of 76 mV and a rms input ripple current of 1.47 A.

$$I_{cirms} = I_{out} \times \sqrt{\frac{V_{out}}{V_{inmin}} \times \frac{(V_{inmin} - V_{out})}{V_{inmin}}} \quad (30)$$

$$\Delta V_{in} = \frac{I_{outmax} \times 0.25}{C_{in} \times f_{sw}} \quad (31)$$

SLOW START CAPACITOR

The slow start capacitor determines the minimum amount of time it takes for the output voltage to reach its nominal programmed value during power up. This is useful if a load requires a controlled voltage slew rate. This is also used if the output capacitance is large and would require large amounts of current to quickly charge the capacitor to the output voltage level. The large currents necessary to charge the capacitor may make the TPS54388-Q1 reach the current limit or excessive current draw from the input power supply may cause the input voltage rail to sag. Limiting the output voltage slew rate solves both of these problems.

The slow start capacitor value can be calculated using [Equation 32](#). For the example circuit, the slow start time is not too critical since the output capacitor value is 44 μF which does not require much current to charge to 1.8 V. The example circuit has the slow start time set to an arbitrary value of 4ms which requires a 10 nF capacitor. In TPS54388-Q1, I_{ss} is 2.2 μA and V_{ref} is 0.800 V.

$$C_{ss}(\text{nF}) = \frac{T_{ss}(\text{ms}) \times I_{ss}(\mu\text{A})}{V_{ref}(\text{V})} \quad (32)$$

BOOTSTRAP CAPACITOR SELECTION

A 0.1 μF ceramic capacitor must be connected between the BOOT to PH pin for proper operation. It is recommended to use a ceramic capacitor with X5R or better grade dielectric. The capacitor should have 10 V or higher voltage rating.

OUTPUT VOLTAGE AND FEEDBACK RESISTORS SELECTION

For the example design, 100 k Ω was selected for R6. Using [Equation 33](#), R7 is calculated as 80 k Ω . The nearest standard 1% resistor is 80.5 k Ω .

$$R7 = \frac{V_{ref}}{V_o - V_{ref}} R6 \quad (33)$$

Due to the internal design of the TPS54388-Q1, there is a minimum output voltage limit for any given input voltage. The output voltage can never be lower than the internal voltage reference of 0.827 V. Above 0.827 V, the output voltage may be limited by the minimum controllable on time. The minimum output voltage in this case is given by [Equation 34](#)

$$V_{outmin} = O_{ntimemin} \times F_{smax} \times (V_{inmax} - I_{outmin} \times 2 \times R_{DS}) - I_{outmin} \times (R_L + R_{DS})$$

Where:

V_{outmin} = minimum achievable output voltage

$O_{ntimemin}$ = minimum controllable on-time (65 ns typical, 120 nsec no load)

F_{smax} = maximum switching frequency including tolerance

V_{inmax} = maximum input voltage

I_{outmin} = minimum load current

R_{DS} = minimum high side MOSFET on resistance (15 - 19 m Ω)

R_L = series resistance of output inductor

(34)

There is also a maximum achievable output voltage which is limited by the minimum off time. The maximum output voltage is given by [Equation 35](#)

$$V_{outmax} = (1 - O_{fftimemax} \times F_{smax}) \times (V_{inmin} - I_{outmax} \times 2 \times R_{DS}) - I_{outmax} \times (R_L + R_{DS})$$

Where:

V_{outmax} = maximum achievable output voltage

$O_{fftimemax}$ = maximum off time (60 nsec typical)

F_{smax} = maximum switching frequency including tolerance

V_{inmin} = minimum input voltage

I_{outmax} = maximum load current

R_{DS} = maximum high side MOSFET on resistance (19 - 30 m Ω)

R_L = series resistance of output inductor

(35)

COMPENSATION

There are several industry techniques used to compensate DC/DC regulators. The method presented here is easy to calculate and yields high phase margins. For most conditions, the regulator has a phase margin between 60 and 90 degrees. The method presented here ignores the effects of the slope compensation that is internal to the TPS54388-Q1. Since the slope compensation is ignored, the actual cross over frequency is usually lower than the cross over frequency used in the calculations.

To get started, the modulator pole, $f_{p\text{mod}}$, and the esr zero, f_{z1} must be calculated using [Equation 36](#) and [Equation 37](#). For C_{out} , derating the capacitor is not needed as the 1.8 V output is a small percentage of the 10 V capacitor rating. If the output is a high percentage of the capacitor rating, use the capacitor manufacturer information to derate the capacitor value. Use [Equation 38](#) and [Equation 39](#) to estimate a starting point for the crossover frequency, f_c . For the example design, $f_{p\text{mod}}$ is 6.03 kHz and $f_{z\text{mod}}$ is 1210 kHz. [Equation 38](#) is the geometric mean of the modulator pole and the esr zero and [Equation 39](#) is the mean of modulator pole and the switching frequency. [Equation 38](#) yields 85.3 kHz and [Equation 39](#) gives 54.9 kHz. Use the lower value of [Equation 38](#) or [Equation 39](#) as the approximate crossover frequency. For this example, f_c is 56 kHz. Next, the compensation components are calculated. A resistor in series with a capacitor is used to create a compensating zero. A capacitor in parallel to these two components forms the compensating pole (if needed).

$$f_{p\text{mod}} = \frac{I_{out\text{max}}}{2\pi \times V_{out} \times C_{out}} \quad (36)$$

$$f_{z\text{mod}} = \frac{1}{2\pi \times R_{esr} \times C_{out}} \quad (37)$$

$$f_c = \sqrt{f_{p\text{mod}} \times f_{z\text{mod}}} \quad (38)$$

$$f_c = \sqrt{f_{p\text{mod}} \times \frac{f_{sw}}{2}} \quad (39)$$

The compensation design takes the following steps:

1. Set up the anticipated cross-over frequency. Use [Equation 40](#) to calculate the compensation network's resistor value. In this example, the anticipated cross-over frequency (f_c) is 56 kHz. The power stage gain ($g_{m\text{ps}}$) is 25 A/V and the error amplifier gain ($g_{m\text{ea}}$) is 245 $\mu\text{A/V}$.

$$R3 = \frac{2\pi \times f_c \times V_o \times C_o}{G_m \times V_{ref} \times V_{I_{gm}}} \quad (40)$$

2. Place compensation zero at the pole formed by the load resistor and the output capacitor. The compensation network's capacitor can be calculated from [Equation 41](#).

$$C3 = \frac{R_o \times C_o}{R3} \quad (41)$$

3. An additional pole can be added to attenuate high frequency noise. In this application, it is not necessary to add it.

From the procedures above, the compensation network includes a 7.68 k Ω resistor and a 3300 pF capacitor.

APPLICATION CURVES

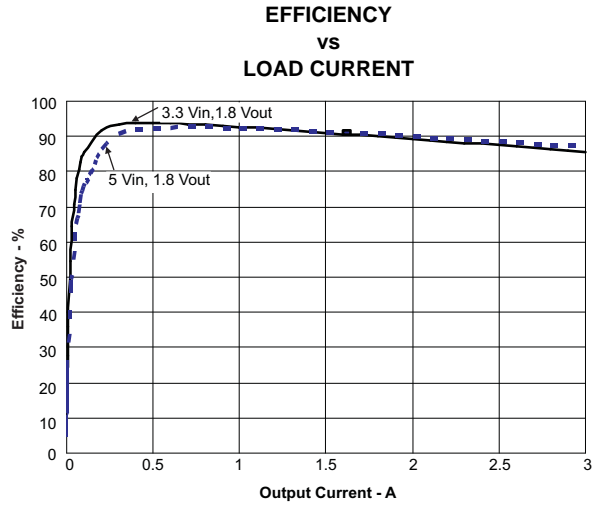

Figure 35.

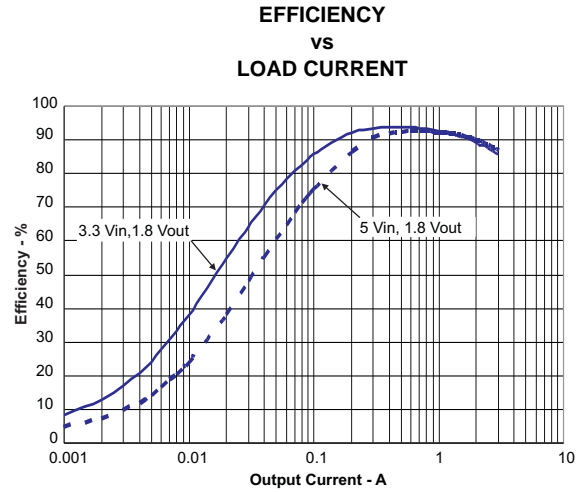

Figure 36.

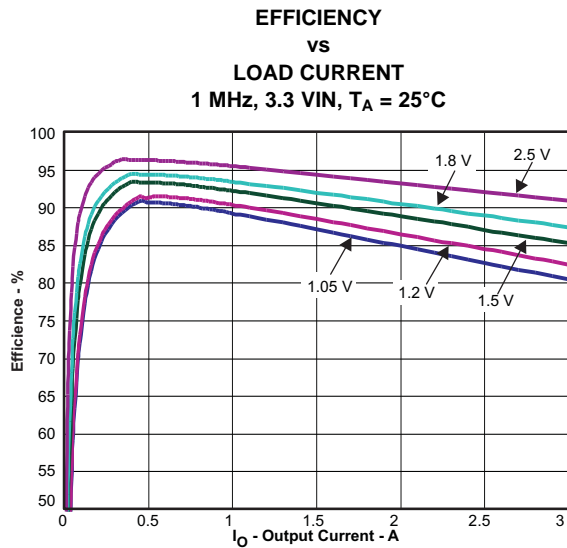

Figure 37.

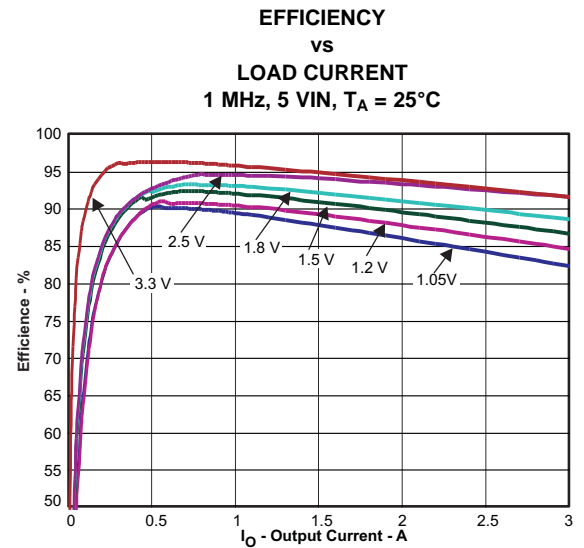

Figure 38.

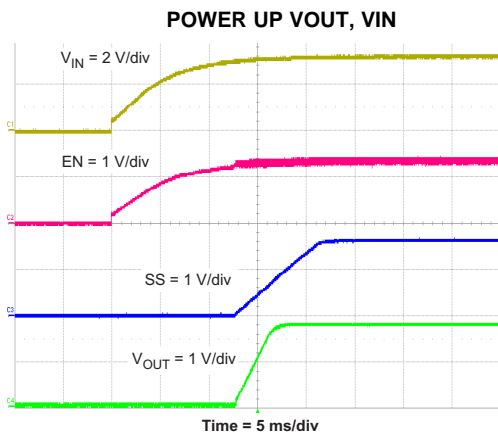

Figure 39.

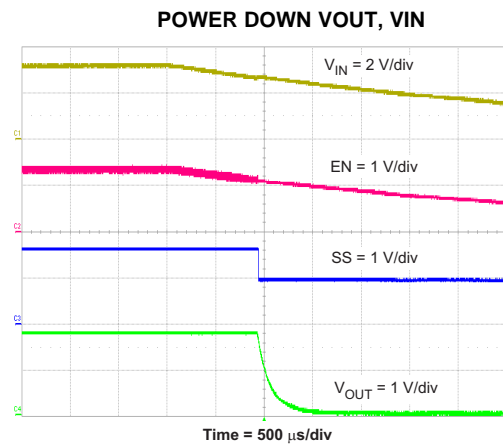

Figure 40.

TRANSIENT RESPONSE, 1.5 A STEP

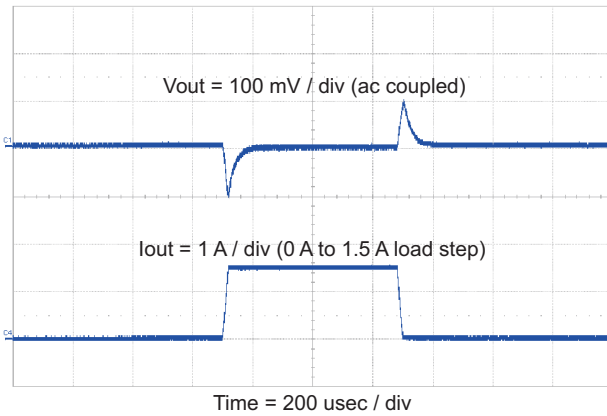

Figure 41.

POWER UP VOUT, VIN

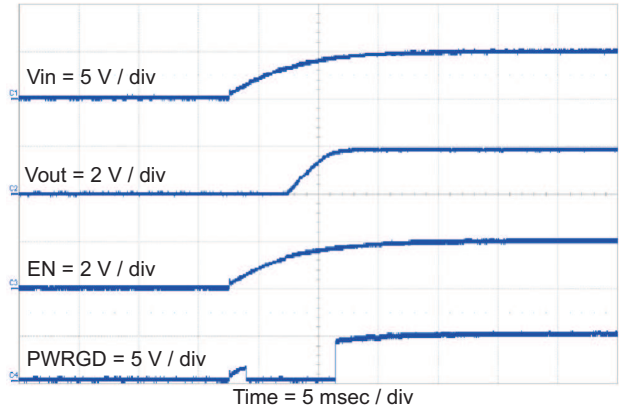

Figure 42.

POWER UP VOUT, EN

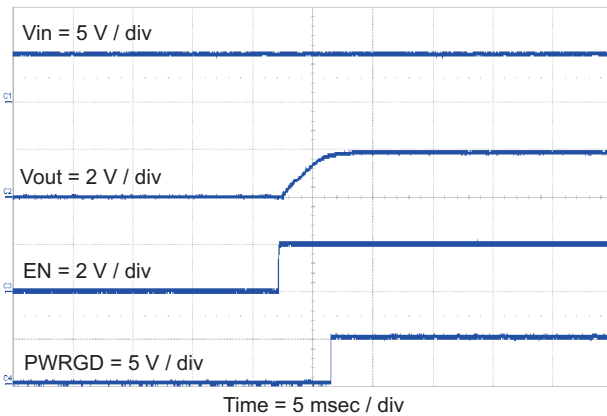

Figure 43.

OUTPUT RIPPLE, 3 A

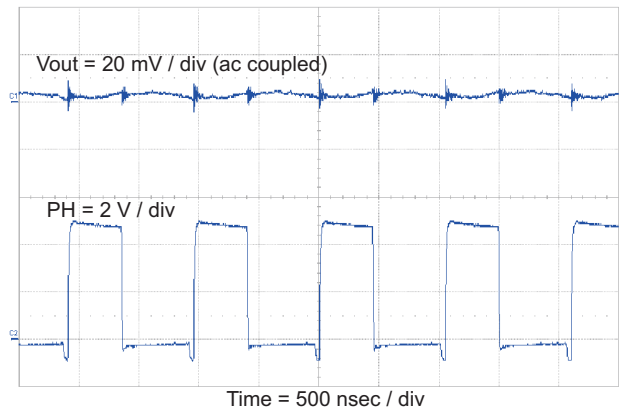

Figure 44.

INPUT RIPPLE, 3 A

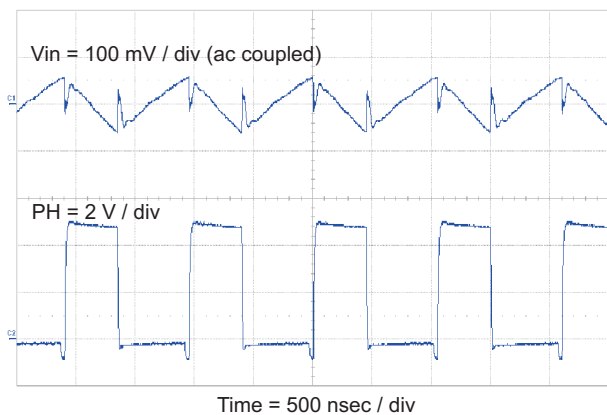

Figure 45.

CLOSED LOOP RESPONSE, VIN (5 V), 3 A

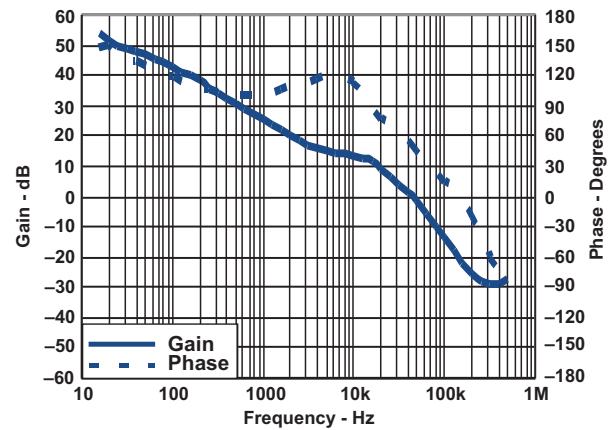

Figure 46.

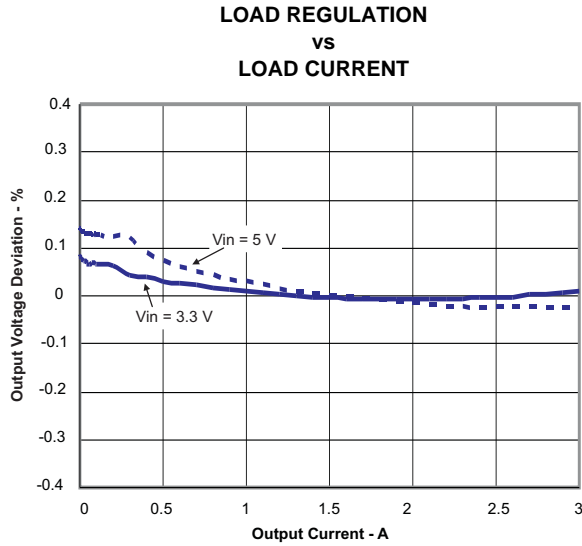

Figure 47.

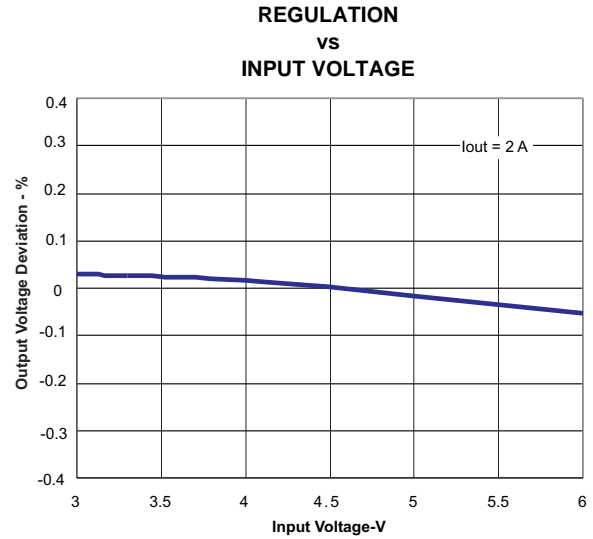

Figure 48.

POWER DISSIPATION ESTIMATE

The following formulas show how to estimate the IC power dissipation under continuous conduction mode (CCM) operation. The power dissipation of the IC (Ptot) includes conduction loss (Pcon), dead time loss (Pd), switching loss (Psw), gate drive loss (Pgd) and supply current loss (Pq).

$$P_{con} = I_o^2 \times R_{DS(on)_Temp}$$

$$P_d = f_{sw} \times I_o \times 0.7 \times 60 \times 10^{-9}$$

$$P_{sw} = 1/2 \times V_{in} \times I_o \times f_{sw} \times 8 \times 10^{-9}$$

$$P_{gd} = 2 \times V_{in} \times f_{sw} \times 2 \times 10^{-9}$$

$$P_q = V_{in} \times 515 \times 10^{-6}$$

Where:

- I_O is the output current (A).
- R_{DS(on)_Temp} is the on-resistance of the high-side MOSFET with given temperature (Ω).
- V_{in} is the input voltage (V).
- f_{sw} is the switching frequency (Hz).

So

$$P_{tot} = P_{con} + P_d + P_{sw} + P_{gd} + P_q$$

For given T_A,

$$T_J = T_A + R_{th} \times P_{tot}$$

For given T_JMAX = 150°C

$$T_{A\,MAX} = T_J\,MAX - R_{th} \times P_{tot}$$

Where:

- P_{tot} is the total device power dissipation (W).
- T_A is the ambient temperature (°C).
- T_J is the junction temperature (°C).
- R_{th} is the thermal resistance of the package (°C/W).
- T_JMAX is maximum junction temperature (°C).
- T_AMAX is maximum ambient temperature (°C).

There are additional power losses in the regulator circuit due to the inductor AC and DC losses and trace resistance that impact the overall efficiency of the regulator.

LAYOUT

Layout is a critical portion of good power supply design. There are several signal paths that conduct fast changing currents or voltages that can interact with stray inductance or parasitic capacitance to generate noise or degrade the power supplies performance. Care should be taken to minimize the loop area formed by the bypass capacitor connections and the VIN pins. See [Figure 49](#) for a PCB layout example. The GND pins and AGND pin should be tied directly to the power pad under the IC. The power pad should be connected to any internal PCB ground planes using multiple vias directly under the IC. Additional vias can be used to connect the top side ground area to the internal planes near the input and output capacitors. For operation at full rated load, the top side ground area along with any additional internal ground planes must provide adequate heat dissipating area.

Locate the input bypass capacitor as close to the IC as possible. The PH pin should be routed to the output inductor. Since the PH connection is the switching node, the output inductor should be located close to the PH pins, and the area of the PCB conductor minimized to prevent excessive capacitive coupling. The boot capacitor must also be located close to the device. The sensitive analog ground connections for the feedback voltage divider, compensation components, slow start capacitor and frequency set resistor should be connected to a separate analog ground trace as shown. The RT/CLK pin is particularly sensitive to noise so the RT resistor should be located as close as possible to the IC and routed with minimal lengths of trace. The additional external components can be placed approximately as shown. It may be possible to obtain acceptable performance with alternate PCB layouts, however this layout has been shown to produce good results and is meant as a guideline.

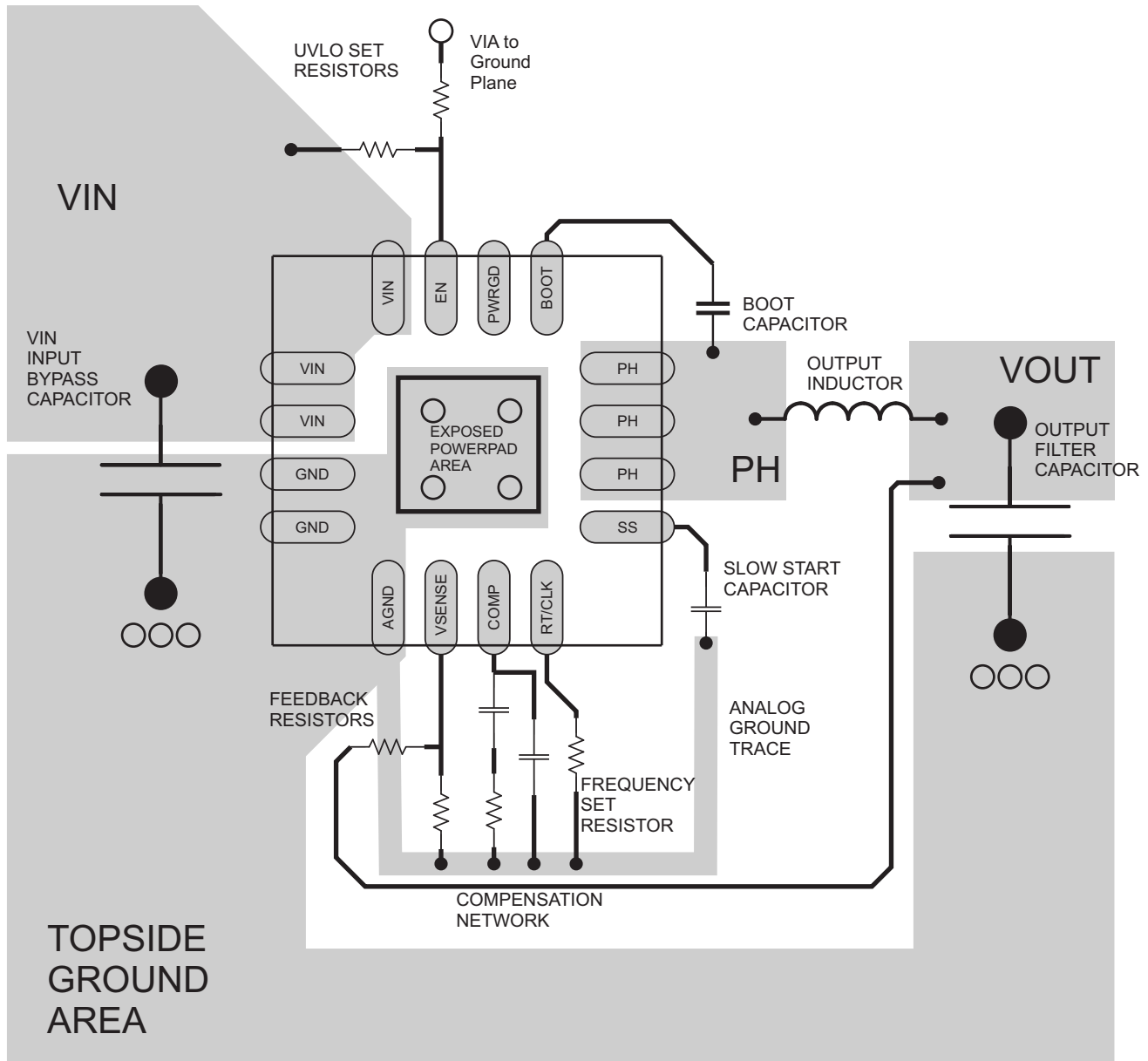

○ VIA to Ground Plane

Figure 49. PCB Layout Example

REVISION HISTORY

Changes from Revision A (June, 2011) to Revision B	Page
• Removed (SWIFT™) from title.	1
• Removed the last two sentences in the description containing SwitcherPro™ and SWIFT™ references.	1
• Removed last sentence of first paragraph, "Use SwitcherPro software for a more accurate design."	25

PACKAGING INFORMATION

Orderable Device	Status ⁽¹⁾	Package Type	Package Drawing	Pins	Package Qty	Eco Plan ⁽²⁾	Lead/ Ball Finish	MSL Peak Temp ⁽³⁾	Samples (Requires Login)
TPS54388QRTERQ1	ACTIVE	WQFN	RTE	16	3000	Green (RoHS & no Sb/Br)	CU NIPDAU	Level-3-260C-168 HR	

⁽¹⁾ The marketing status values are defined as follows:

ACTIVE: Product device recommended for new designs.

LIFEBUY: TI has announced that the device will be discontinued, and a lifetime-buy period is in effect.

NRND: Not recommended for new designs. Device is in production to support existing customers, but TI does not recommend using this part in a new design.

PREVIEW: Device has been announced but is not in production. Samples may or may not be available.

OBSOLETE: TI has discontinued the production of the device.

⁽²⁾ Eco Plan - The planned eco-friendly classification: Pb-Free (RoHS), Pb-Free (RoHS Exempt), or Green (RoHS & no Sb/Br) - please check <http://www.ti.com/productcontent> for the latest availability information and additional product content details.

TBD: The Pb-Free/Green conversion plan has not been defined.

Pb-Free (RoHS): TI's terms "Lead-Free" or "Pb-Free" mean semiconductor products that are compatible with the current RoHS requirements for all 6 substances, including the requirement that lead not exceed 0.1% by weight in homogeneous materials. Where designed to be soldered at high temperatures, TI Pb-Free products are suitable for use in specified lead-free processes.

Pb-Free (RoHS Exempt): This component has a RoHS exemption for either 1) lead-based flip-chip solder bumps used between the die and package, or 2) lead-based die adhesive used between the die and leadframe. The component is otherwise considered Pb-Free (RoHS compatible) as defined above.

Green (RoHS & no Sb/Br): TI defines "Green" to mean Pb-Free (RoHS compatible), and free of Bromine (Br) and Antimony (Sb) based flame retardants (Br or Sb do not exceed 0.1% by weight in homogeneous material)

⁽³⁾ MSL, Peak Temp. -- The Moisture Sensitivity Level rating according to the JEDEC industry standard classifications, and peak solder temperature.

Important Information and Disclaimer: The information provided on this page represents TI's knowledge and belief as of the date that it is provided. TI bases its knowledge and belief on information provided by third parties, and makes no representation or warranty as to the accuracy of such information. Efforts are underway to better integrate information from third parties. TI has taken and continues to take reasonable steps to provide representative and accurate information but may not have conducted destructive testing or chemical analysis on incoming materials and chemicals. TI and TI suppliers consider certain information to be proprietary, and thus CAS numbers and other limited information may not be available for release.

In no event shall TI's liability arising out of such information exceed the total purchase price of the TI part(s) at issue in this document sold by TI to Customer on an annual basis.

TAPE AND REEL INFORMATION
REEL DIMENSIONS

TAPE DIMENSIONS

A0	Dimension designed to accommodate the component width
B0	Dimension designed to accommodate the component length
K0	Dimension designed to accommodate the component thickness
W	Overall width of the carrier tape
P1	Pitch between successive cavity centers

TAPE AND REEL INFORMATION

*All dimensions are nominal

Device	Package Type	Package Drawing	Pins	SPQ	Reel Diameter (mm)	Reel Width W1 (mm)	A0 (mm)	B0 (mm)	K0 (mm)	P1 (mm)	W (mm)	Pin1 Quadrant
TPS54388QRTERQ1	WQFN	RTE	16	3000	330.0	12.4	3.3	3.3	1.1	8.0	12.0	Q2

TAPE AND REEL BOX DIMENSIONS



*All dimensions are nominal

Device	Package Type	Package Drawing	Pins	SPQ	Length (mm)	Width (mm)	Height (mm)
TPS54388QRTERQ1	WQFN	RTE	16	3000	367.0	367.0	35.0

MECHANICAL DATA

RTE (S-PWQFN-N16)

PLASTIC QUAD FLATPACK NO-LEAD



4205254/D 01/11

- NOTES:
- A. All linear dimensions are in millimeters. Dimensioning and tolerancing per ASME Y14.5M-1994.
 - B. This drawing is subject to change without notice.
 - C. Quad Flatpack, No-leads (QFN) package configuration.
 -  The package thermal pad must be soldered to the board for thermal and mechanical performance. See the Product Data Sheet for details regarding the exposed thermal pad dimensions.
 - E. Falls within JEDEC MO-220.

THERMAL PAD MECHANICAL DATA

RTE (S-PWQFN-N16)

PLASTIC QUAD FLATPACK NO-LEAD

THERMAL INFORMATION

This package incorporates an exposed thermal pad that is designed to be attached directly to an external heatsink. The thermal pad must be soldered directly to the printed circuit board (PCB). After soldering, the PCB can be used as a heatsink. In addition, through the use of thermal vias, the thermal pad can be attached directly to the appropriate copper plane shown in the electrical schematic for the device, or alternatively, can be attached to a special heatsink structure designed into the PCB. This design optimizes the heat transfer from the integrated circuit (IC).

For information on the Quad Flatpack No-Lead (QFN) package and its advantages, refer to Application Report, QFN/SON PCB Attachment, Texas Instruments Literature No. SLUA271. This document is available at www.ti.com.

The exposed thermal pad dimensions for this package are shown in the following illustration.

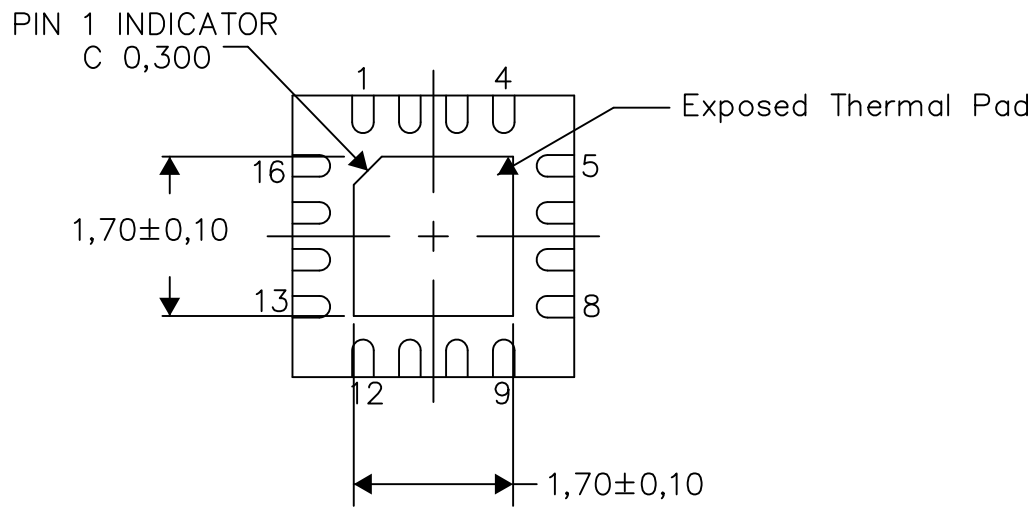

Bottom View

Exposed Thermal Pad Dimensions

4206446-3/J 05/12

NOTE: A. All linear dimensions are in millimeters

RTE (S-PWQFN-N16)

PLASTIC QUAD FLATPACK NO-LEAD

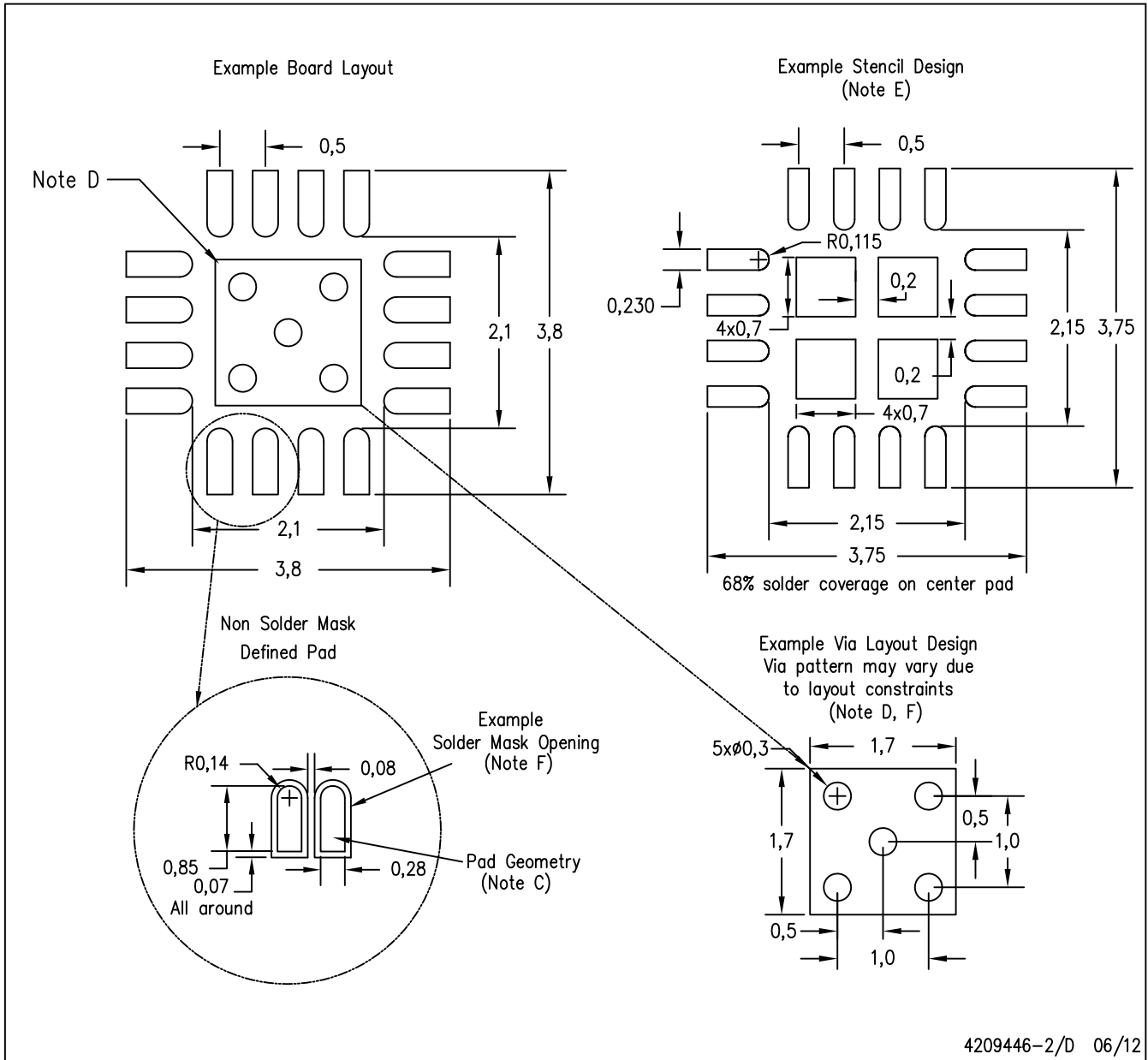

- NOTES:
- A. All linear dimensions are in millimeters.
 - B. This drawing is subject to change without notice.
 - C. Publication IPC-7351 is recommended for alternate designs.
 - D. This package is designed to be soldered to a thermal pad on the board. Refer to Application Note, Quad Flat-Pack Packages, Texas Instruments Literature No. SLUA271, and also the Product Data Sheets for specific thermal information, via requirements, and recommended board layout. These documents are available at www.ti.com <<http://www.ti.com>>.
 - E. Laser cutting apertures with trapezoidal walls and also rounding corners will offer better paste release. Customers should contact their board assembly site for stencil design recommendations. Refer to IPC 7525 for stencil design considerations.
 - F. Customers should contact their board fabrication site for minimum solder mask web tolerances between signal pads.

IMPORTANT NOTICE

Texas Instruments Incorporated and its subsidiaries (TI) reserve the right to make corrections, enhancements, improvements and other changes to its semiconductor products and services per JESD46C and to discontinue any product or service per JESD48B. Buyers should obtain the latest relevant information before placing orders and should verify that such information is current and complete. All semiconductor products (also referred to herein as "components") are sold subject to TI's terms and conditions of sale supplied at the time of order acknowledgment.

TI warrants performance of its components to the specifications applicable at the time of sale, in accordance with the warranty in TI's terms and conditions of sale of semiconductor products. Testing and other quality control techniques are used to the extent TI deems necessary to support this warranty. Except where mandated by applicable law, testing of all parameters of each component is not necessarily performed.

TI assumes no liability for applications assistance or the design of Buyers' products. Buyers are responsible for their products and applications using TI components. To minimize the risks associated with Buyers' products and applications, Buyers should provide adequate design and operating safeguards.

TI does not warrant or represent that any license, either express or implied, is granted under any patent right, copyright, mask work right, or other intellectual property right relating to any combination, machine, or process in which TI components or services are used. Information published by TI regarding third-party products or services does not constitute a license to use such products or services or a warranty or endorsement thereof. Use of such information may require a license from a third party under the patents or other intellectual property of the third party, or a license from TI under the patents or other intellectual property of TI.

Reproduction of significant portions of TI information in TI data books or data sheets is permissible only if reproduction is without alteration and is accompanied by all associated warranties, conditions, limitations, and notices. TI is not responsible or liable for such altered documentation. Information of third parties may be subject to additional restrictions.

Resale of TI components or services with statements different from or beyond the parameters stated by TI for that component or service voids all express and any implied warranties for the associated TI component or service and is an unfair and deceptive business practice. TI is not responsible or liable for any such statements.

Buyer acknowledges and agrees that it is solely responsible for compliance with all legal, regulatory and safety-related requirements concerning its products, and any use of TI components in its applications, notwithstanding any applications-related information or support that may be provided by TI. Buyer represents and agrees that it has all the necessary expertise to create and implement safeguards which anticipate dangerous consequences of failures, monitor failures and their consequences, lessen the likelihood of failures that might cause harm and take appropriate remedial actions. Buyer will fully indemnify TI and its representatives against any damages arising out of the use of any TI components in safety-critical applications.

In some cases, TI components may be promoted specifically to facilitate safety-related applications. With such components, TI's goal is to help enable customers to design and create their own end-product solutions that meet applicable functional safety standards and requirements. Nonetheless, such components are subject to these terms.

No TI components are authorized for use in FDA Class III (or similar life-critical medical equipment) unless authorized officers of the parties have executed a special agreement specifically governing such use.

Only those TI components which TI has specifically designated as military grade or "enhanced plastic" are designed and intended for use in military/aerospace applications or environments. Buyer acknowledges and agrees that any military or aerospace use of TI components which have **not** been so designated is solely at the Buyer's risk, and that Buyer is solely responsible for compliance with all legal and regulatory requirements in connection with such use.

TI has specifically designated certain components which meet ISO/TS16949 requirements, mainly for automotive use. Components which have not been so designated are neither designed nor intended for automotive use; and TI will not be responsible for any failure of such components to meet such requirements.

Products

Audio	www.ti.com/audio
Amplifiers	amplifier.ti.com
Data Converters	dataconverter.ti.com
DLP® Products	www.dlp.com
DSP	dsp.ti.com
Clocks and Timers	www.ti.com/clocks
Interface	interface.ti.com
Logic	logic.ti.com
Power Mgmt	power.ti.com
Microcontrollers	microcontroller.ti.com
RFID	www.ti-rfid.com
OMAP Mobile Processors	www.ti.com/omap
Wireless Connectivity	www.ti.com/wirelessconnectivity

Applications

Automotive and Transportation	www.ti.com/automotive
Communications and Telecom	www.ti.com/communications
Computers and Peripherals	www.ti.com/computers
Consumer Electronics	www.ti.com/consumer-apps
Energy and Lighting	www.ti.com/energy
Industrial	www.ti.com/industrial
Medical	www.ti.com/medical
Security	www.ti.com/security
Space, Avionics and Defense	www.ti.com/space-avionics-defense
Video and Imaging	www.ti.com/video

TI E2E Community e2e.ti.com