

TPS54327 3-A Output Single Synchronous Step-Down Switcher With Integrated FET

1 Features

- D-CAP2™ Mode Enables Fast Transient Response
- Low-Output Ripple and Allows Ceramic Output Capacitor
- Wide V_{IN} Input Voltage Range: 4.5 V to 18 V
- Output Voltage Range: 0.76 V to 7 V
- Highly Efficient Integrated FETs Optimized for Lower Duty Cycle Applications
 - 100 m Ω (High-Side) and 70 m Ω (Low-Side)
- High Efficiency, Less Than 10 μ A at shutdown
- High Initial Bandgap Reference Accuracy
- Adjustable Soft Start
- Prebiased Soft Start
- 700-kHz Switching Frequency (f_{SW})
- Cycle-By-Cycle Overcurrent Limit

2 Applications

- Wide Range of Applications for Low Voltage System
 - Digital TV Power Supply
 - High Definition Blu-ray Disc™ Players
 - Networking Home Terminal
 - Digital Set Top Box (STB)

Simplified Schematic

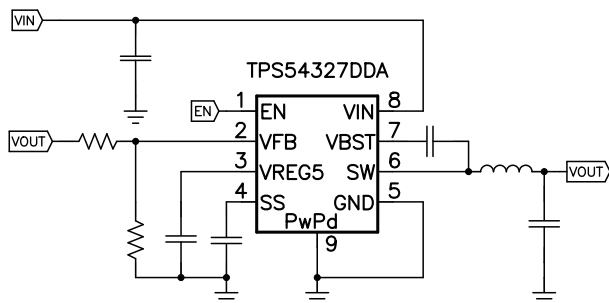

3 Description

The TPS54327 device is an adaptive on-time D-CAP2™ mode synchronous buck converter. The TPS54327 enables system designers to complete the suite of various end equipment's power bus regulators with a cost effective, low component count, low standby current solution. The main control loop for the TPS54327 uses the D-CAP2 mode control which provides a fast transient response with no external compensation components. The TPS54327 also has a proprietary circuit that enables the device to adopt to both low equivalent series resistance (ESR) output capacitors, such as POSCAP or SP-CAP, and ultra-low ESR ceramic capacitors. The device operates from 4.5-V to 18-V V_{IN} input. The output voltage can be programmed between 0.76 V and 7 V. The device also features an adjustable soft start time. The TPS54327 is available in the 8-pin DDA package and 10-pin DRC, and is designed to operate from -40°C to 85°C .

Device Information⁽¹⁾

PART NUMBER	PACKAGE	BODY SIZE (NOM)
TPS54327	HSOP (8)	4.89 mm x 3.90 mm
	VSON (10)	3.00 mm x 3.00 mm

(1) For all available packages, see the orderable addendum at the end of the data sheet.

TPS54327 Transient Response

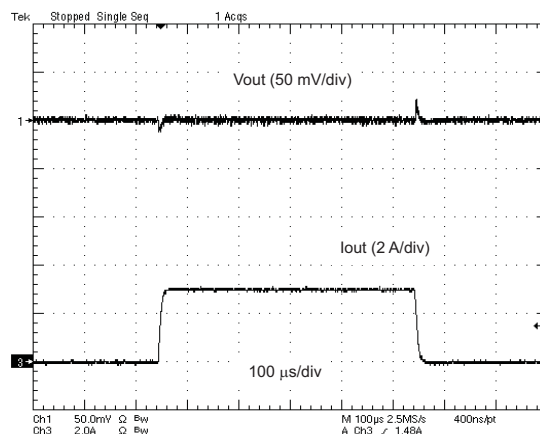

Table of Contents

1 Features	1	7.4 Device Functional Modes.....	9
2 Applications	1	8 Application and Implementation	10
3 Description	1	8.1 Application Information.....	10
4 Revision History	2	8.2 Typical Application	10
5 Pin Configuration and Functions	3	9 Power Supply Recommendations	14
6 Specifications	4	10 Layout	14
6.1 Absolute Maximum Ratings	4	10.1 Layout Guidelines	14
6.2 ESD Ratings.....	4	10.2 Layout Examples.....	15
6.3 Recommended Operating Conditions.....	4	10.3 Thermal Considerations	17
6.4 Thermal Information	5	11 Device and Documentation Support	18
6.5 Electrical Characteristics.....	5	11.1 Documentation Support	18
6.6 Typical Characteristics	6	11.2 Community Resources.....	18
7 Detailed Description	7	11.3 Trademarks	18
7.1 Overview	7	11.4 Electrostatic Discharge Caution.....	18
7.2 Functional Block Diagram	7	11.5 Glossary	18
7.3 Feature Description.....	7	12 Mechanical, Packaging, and Orderable Information	18

4 Revision History

NOTE: Page numbers for previous revisions may differ from page numbers in the current version.

Changes from Revision B (January 2012) to Revision C	Page
• Added <i>Pin Configuration and Functions</i> section, <i>ESD Ratings</i> table, <i>Feature Description</i> section, <i>Device Functional Modes</i> , <i>Application and Implementation</i> section, <i>Power Supply Recommendations</i> section, <i>Layout</i> section, <i>Device and Documentation Support</i> section, and <i>Mechanical, Packaging, and Orderable Information</i> section	1
• Removed <i>Ordering Information</i> table	1

Changes from Revision A (October 2011) to Revision B	Page
• Removed (SWIFT™) from the data sheet title	1
• Added "and 10-pin DRC" to the DESCRIPTION	1
• Added the DRC-10 Pin package pin out	3
• Changed the VBST(vs SW) MAX value From: 6V to 6.5V in the Abs Max Ratings table	4
• Changed the VBST(vs SW) MAX value From: 5.7V to 6V in the ROC table.....	4
• Changed UVLO Min Value From: 0.19 V To: 0.17 V	5
• Added Added a conditions statement "VIN = 12 V, TA = 25°C" to the TYPICAL CHARACTERISTICS	6
• Changed Figure 10 title From: 1.05-V, 50-mA to 2-A LOAD TRANSIENT RESPONSE To: 1.05-V, 0-A to 3-A LOAD TRANSIENT RESPONSE	12
• Changed Figure 12 Figure Title From: (I _O = 2 A) To: (I _O = 3 A).....	12
• Changed Figure 13 Figure Title From: (I _O = 2 A) To: (I _O = 3 A).....	12
• Added Figure 17	16

Changes from Original (November 2010) to Revision A	Page
• Changed Pin 6 (SW) Description In the Pin Functions table	3
• Changed the V _{ENH} Min value From: 2 V To: 1.6 V in the Logic Threshold section	5
• Changed Figure 4	6
• Changed Equation 1	8

5 Pin Configuration and Functions

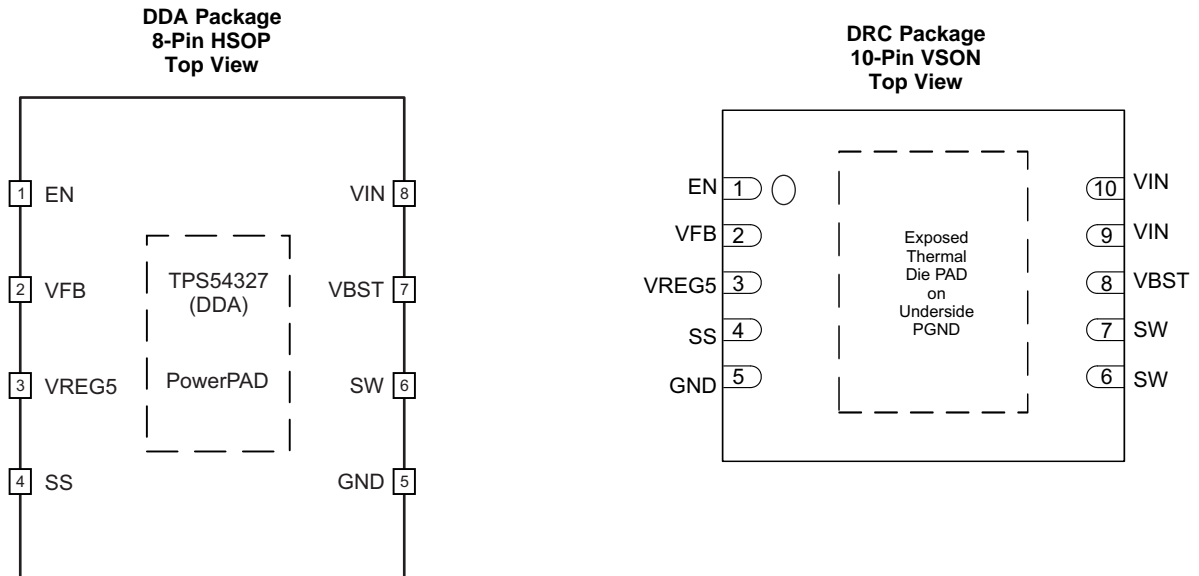

Pin Functions

NAME	PIN		TYPE	DESCRIPTION
	HSOP	VSON		
EN	1	1	I	Enable input control. Active high.
VFB	2	2	I	Converter feedback input. Connect to output voltage with feedback resistor divider.
VREG5	3	3	O	5.5 V power supply output. A capacitor (typical 1 μ F) should be connected to GND. VREG5 is not active when EN is low.
SS	4	4	O	Soft-start control. An external capacitor should be connected to GND.
GND	5	5	G	Ground pin. Power ground return for switching circuit. Connect sensitive SS and VFB returns to GND at a single point.
SW	6	6, 7	O	Switch node connection between high-side NFET and low-side NFET.
VBST	7	8	I	Supply input for the high-side FET gate drive circuit. Connect 0.1 μ F capacitor between VBST and SW pins. An internal diode is connected between VREG5 and VBST.
VIN	8	9, 10	P	Input voltage supply pin.
PowerPAD	Back side	—	G	PowerPAD of the package. Must be soldered to achieve appropriate dissipation. Must be connected to GND.
Exposed thermal pad	—	Back side	G	Thermal pad of the package. PGND power ground return of internal low-side FET. Must be soldered to achieve appropriate dissipation.

6 Specifications

6.1 Absolute Maximum Ratings

over operating free-air temperature range (unless otherwise noted) ⁽¹⁾

		MIN	MAX	UNIT
Input voltage	VIN, EN	-0.3	20	V
	VBST	-0.3	26	V
	VBST (10 ns transient)	-0.3	28	V
	VBST (vs SW)	-0.3	6.5	V
	VFB, SS	-0.3	6.5	V
	SW	-2	20	V
	SW (10 ns transient)	-3	22	V
Output voltage	VREG5	-0.3	6.5	V
	GND	-0.3	0.3	V
Voltage from GND to thermal pad, V _{diff}		-0.2	0.2	V
Operating junction temperature, T _J		-40	150	°C
Storage temperature, T _{stg}		-55	150	°C

(1) Stresses beyond those listed under *Absolute Maximum Ratings* may cause permanent damage to the device. These are stress ratings only, and functional operation of the device at these or any other conditions beyond those indicated under *Recommended Operating Conditions* is not implied. Exposure to absolute-maximum-rated conditions for extended periods may affect device reliability.

6.2 ESD Ratings

		VALUE	UNIT
V _(ESD) Electrostatic discharge	Human body model (HBM), per ANSI/ESDA/JEDEC JS-001 ⁽¹⁾	±2000	V
	Charged-device model (CDM), per JEDEC specification JESD22-C101 ⁽²⁾	±500	

(1) JEDEC document JEP155 states that 500-V HBM allows safe manufacturing with a standard ESD control process.

(2) JEDEC document JEP157 states that 250-V CDM allows safe manufacturing with a standard ESD control process.

6.3 Recommended Operating Conditions

over operating free-air temperature range (unless otherwise noted)

		MIN	MAX	UNIT	
V _{IN}	Supply input voltage	4.5	18	V	
V _I	Input voltage	VBST	-0.1	24	V
		VBST (10 ns transient)	-0.1	27	
		VBST(vs SW)	-0.1	6	
		SS	-0.1	5.7	
		EN	-0.1	18	
		VFB	-0.1	5.5	
		SW	-1.8	18	
		SW (10 ns transient)	-3	21	
	GND	-0.1	0.1		
V _O	Output voltage	VREG5	-0.1	5.7	V
I _O	Output Current	I _{VREG5}	0	10	mA
T _A	Operating free-air temperature	-40	85	°C	
T _J	Operating junction temperature	-40	150	°C	

6.4 Thermal Information

THERMAL METRIC ⁽¹⁾		TPS54327		UNIT
		DDA (HSOP)	DRC (VSON)	
		8 PINS	10 PINS	
R _{θJA}	Junction-to-ambient thermal resistance	42.1	43.9	°C/W
R _{θJC(top)}	Junction-to-case (top) thermal resistance	50.9	55.4	°C/W
R _{θJB}	Junction-to-board thermal resistance	31.8	18.9	°C/W
ψ _{JT}	Junction-to-top characterization parameter	5	0.7	°C/W
ψ _{JB}	Junction-to-board characterization parameter	13.5	19.1	°C/W
R _{θJC(bot)}	Junction-to-case (bottom) thermal resistance	7.1	5.3	°C/W

(1) For more information about traditional and new thermal metrics, see the *Semiconductor and IC Package Thermal Metrics* application report, [SPRA953](#).

6.5 Electrical Characteristics

over operating free-air temperature range V_{IN} = 12 V (unless otherwise noted)

PARAMETER		TEST CONDITIONS	MIN	TYP	MAX	UNIT
SUPPLY CURRENT						
I _{VIN}	Operating - non-switching supply current	V _{IN} current, T _A = 25°C, EN = 5 V, V _{FB} = 0.8 V		800	1200	μA
I _{VINSDN}	Shutdown supply current	V _{IN} current, T _A = 25°C, EN = 0 V		1.8	10	μA
LOGIC THRESHOLD						
V _{ENH}	EN high-level input voltage	EN	1.6			V
V _{ENL}	EN low-level input voltage	EN			0.45	V
V_{FB} VOLTAGE AND DISCHARGE RESISTANCE						
V _{FBTH}	V _{FB} threshold voltage	T _A = 25°C, V _O = 1.05 V, continuous mode	749	765	781	mV
I _{VFB}	V _{FB} input current	V _{FB} = 0.8 V, T _A = 25°C		0	±0.1	μA
V_{REG5} OUTPUT						
V _{VREG5}	V _{REG5} output voltage	T _A = 25°C, 6 V < V _{IN} < 18 V, 0 < I _{VREG5} < 5 mA	5.2	5.5	5.7	V
V _{LN5}	Line regulation	6 V < V _{IN} < 18 V, I _{VREG5} = 5 mA			25	mV
V _{LD5}	Load regulation	0 mA < I _{VREG5} < 5 mA			100	mV
I _{VREG5}	Output current	V _{IN} = 6 V, V _{REG5} = 4 V, T _A = 25°C		60		mA
MOSFET						
R _{DS(on)h}	High-side switch resistance	25°C, V _{BST} - SW = 5.5 V		100		mΩ
R _{DS(on)l}	Low-side switch resistance	25°C		70		mΩ
CURRENT LIMIT						
I _{ocl}	Current limit	L out = 1.5 μH ⁽¹⁾ , T _A = -20°C to 85°C	3.5	4.2	5.7	A
THERMAL SHUTDOWN						
T _{SDN}	Thermal shutdown threshold	Shutdown temperature ⁽¹⁾		165		°C
		Hysteresis ⁽¹⁾		30		
ON-TIME TIMER CONTROL						
t _{ON}	ON-time	V _{IN} = 12 V, V _O = 1.05 V		150		ns
t _{OFF(MIN)}	Minimum OFF-time	T _A = 25°C, V _{FB} = 0.7 V		260	310	ns
SOFT START						
I _{SSC}	SS charge current	V _{SS} = 0 V	1.4	2	2.6	μA
I _{SSD}	SS discharge current	V _{SS} = 0.5 V	0.05	0.1		mA
UVLO						
UVLO	UVLO threshold	Wakeup V _{REG5} voltage	3.45	3.75	4.05	V
		Hysteresis V _{REG5} voltage	0.17	0.32	0.45	

(1) Not production tested.

6.6 Typical Characteristics

V_{IN} = 12 V, T_A = 25°C (unless otherwise noted)

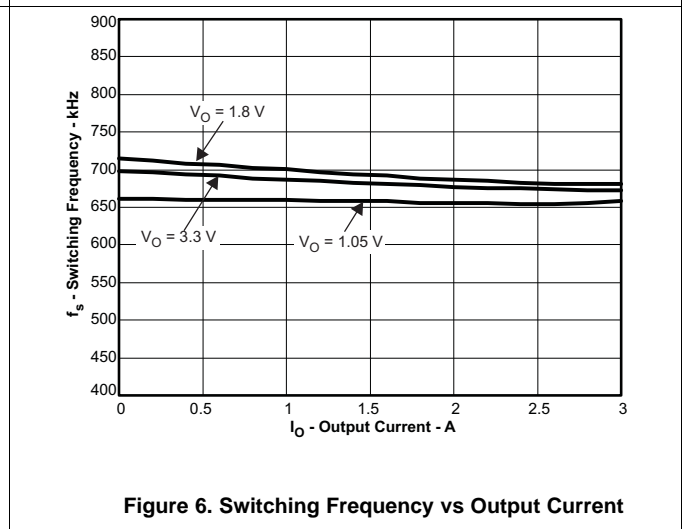
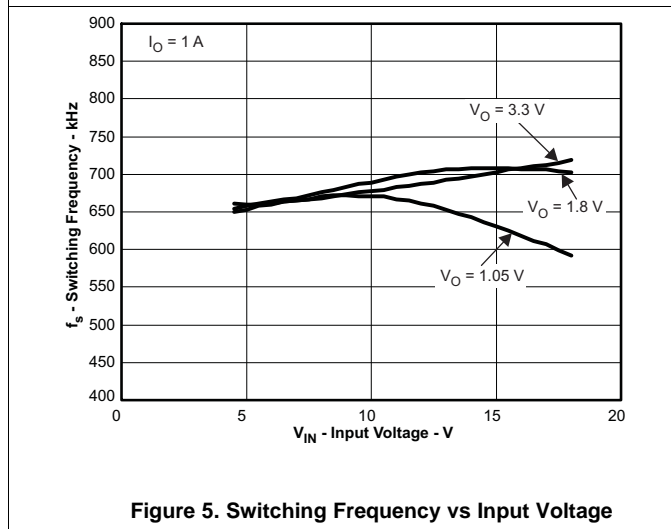
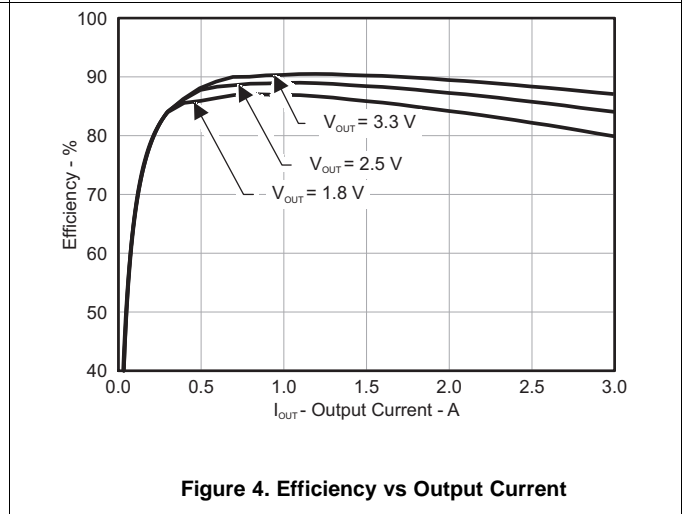
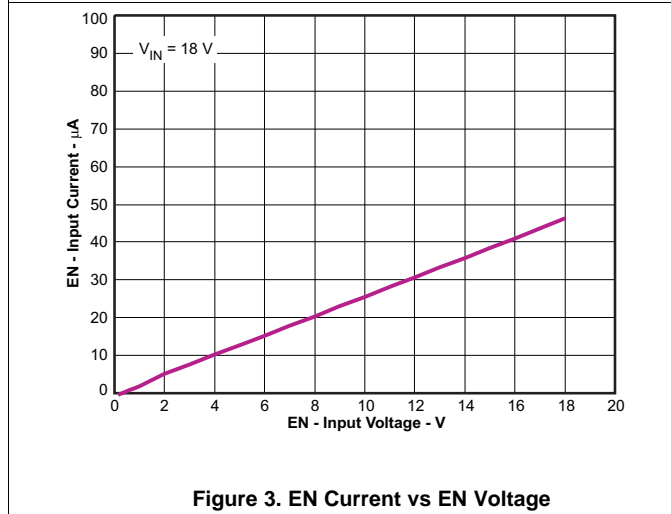
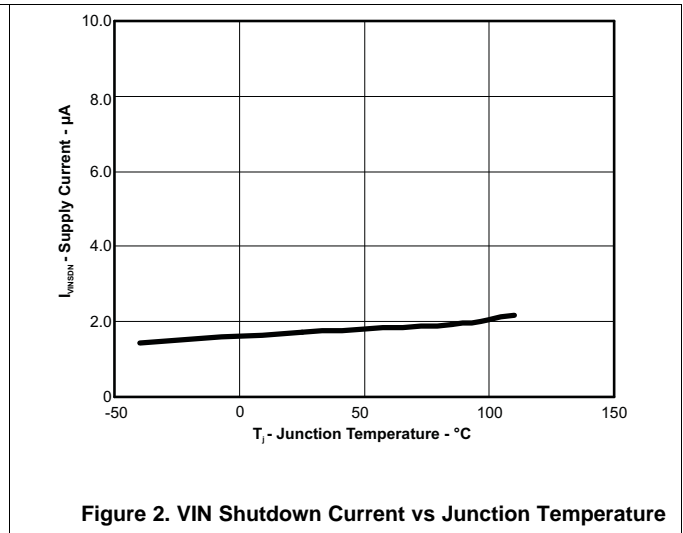
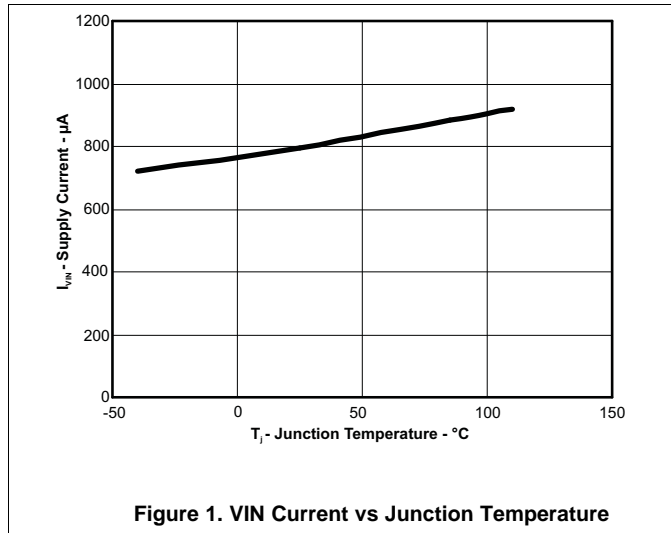

7 Detailed Description

7.1 Overview

The TPS54327 device is a 3-A synchronous step-down (buck) converter with two integrated N-channel MOSFETs. It operates using D-CAP2 mode control. The fast transient response of D-CAP2 control reduces the output capacitance required to meet a specific level of performance. Proprietary internal circuitry allows the use of low ESR output capacitors including ceramic and special polymer types.

7.2 Functional Block Diagram

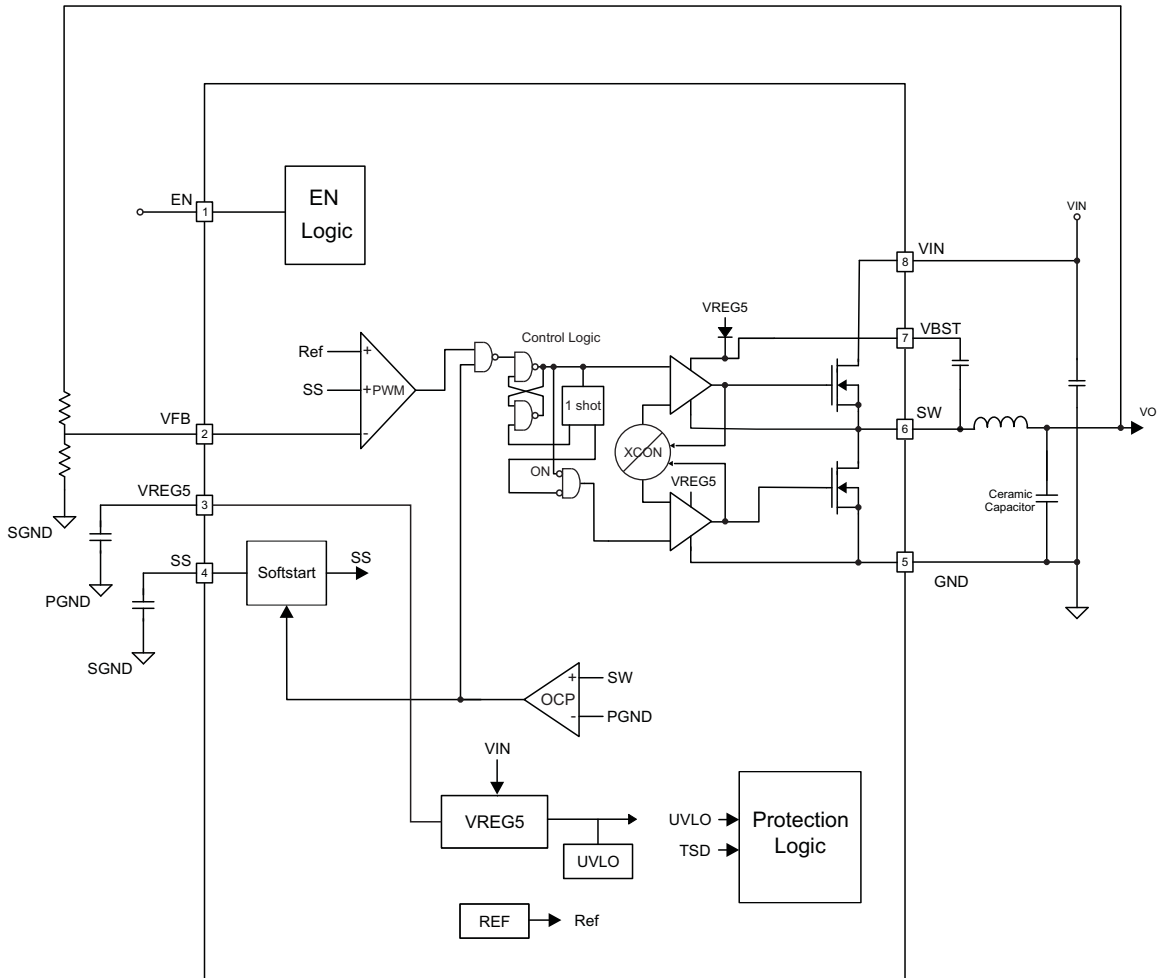

7.3 Feature Description

7.3.1 PWM Operation

The main control loop of the TPS54327 is an adaptive ON-time pulse width modulation (PWM) controller that supports a proprietary D-CAP2 mode control. D-CAP2 mode control combines constant on-time control with an internal compensation circuit for pseudo-fixed frequency and low external component count configuration with both low ESR and ceramic output capacitors. It is stable even with virtually no ripple at the output.

Feature Description (continued)

At the beginning of each cycle, the high-side MOSFET is turned on. This MOSFET is turned off after internal one shot timer expires. This one shot is set by the converter input voltage, VIN, and the output voltage, VO, to maintain a pseudo-fixed frequency over the input voltage range, hence it is called adaptive on-time control. The one-shot timer is reset and the high-side MOSFET is turned on again when the feedback voltage falls below the reference voltage. An internal ramp is added to reference voltage to simulate output ripple, eliminating the need for ESR induced output ripple from D-CAP2 mode control.

7.3.2 PWM Frequency and Adaptive ON-Time Control

TPS54327 uses an adaptive on-time control scheme and does not have a dedicated on-board oscillator. The TPS54327 runs with a pseudo-constant frequency of 700 kHz by using the input voltage and output voltage to set the on-time one-shot timer. The on-time is inversely proportional to the input voltage and proportional to the output voltage, therefore, when the duty ratio is VOUT/VIN, the frequency is constant.

7.3.3 Soft-Start and Prebiased Soft-Start

The soft start function is adjustable. When the EN pin becomes high, 2-μA current begins charging the capacitor which is connected from the SS pin to GND. Smooth control of the output voltage is maintained during start up. The equation for the slow start time is shown in Equation 1. VFB voltage is 0.765 V and SS pin source current is 2 μA.

$$t_{SS}(\text{ms}) = \frac{C6(\text{nF}) \times V_{REF} \times 1.1}{I_{SS}(\mu\text{A})} = \frac{C6(\text{nF}) \times 0.765 \times 1.1}{2} \quad (1)$$

The TPS54327 contains a unique circuit to prevent current from being pulled from the output during start-up if the output is prebiased. When the soft-start commands a voltage higher than the prebias level (internal soft start becomes greater than feedback voltage VFB), the controller slowly activates synchronous rectification by starting the first low side FET gate driver pulses with a narrow on-time. It then increments that on-time on a cycle-by-cycle basis until it coincides with the time dictated by (1-D), where D is the duty cycle of the converter. This scheme prevents the initial sinking of the prebias output, and ensure that the out voltage (VO) starts and ramps up smoothly into regulation and the control loop is given time to transition from prebiased start-up to normal mode operation.

7.3.4 Current Protection

The output overcurrent protection (OCP) is implemented using a cycle-by-cycle valley detect control circuit. The switch current is monitored by measuring the low-side FET switch voltage between the SW pin and GND. This voltage is proportional to the switch current. To improve accuracy, the voltage sensing is temperature compensated.

During the on time of the high-side FET switch, the switch current increases at a linear rate determined by Vin, Vout, the on-time and the output inductor value. During the on time of the low-side FET switch, this current decreases linearly. The average value of the switch current is the load current IOUT. The TPS54327 constantly monitors the low-side FET switch voltage, which is proportional to the switch current, during the low-side on-time. If the measured voltage is above the voltage proportional to the current limit, an internal counter is incremented per each SW cycle and the converter maintains the low-side switch on until the measured voltage is below the voltage corresponding to the current limit at which time the switching cycle is terminated and a new switching cycle begins. In subsequent switching cycles, the on-time is set to a fixed value and the current is monitored in the same manner. If the overcurrent condition exists for 7 consecutive switching cycles, the internal OCL threshold is set to a lower level, reducing the available output current. When a switching cycle occurs where the switch current is not above the lower OCL threshold, the counter is reset and the OCL limit is returned to the higher value.

There are some important considerations for this type of overcurrent protection. The load current one half of the peak-to-peak inductor current higher than the overcurrent threshold. Also when the current is being limited, the output voltage tends to fall as the demanded load current may be higher than the current available from the converter. This may cause the output voltage to fall. When the overcurrent condition is removed, the output voltage will return to the regulated value. This protection is nonlatching.

Feature Description (continued)

7.3.5 UVLO Protection

Undervoltage lock out protection (UVLO) monitors the voltage of the V_{REG5} pin. When the V_{REG5} voltage is lower than UVLO threshold voltage, the TPS54327 is shut off. This protection is non-latching.

7.3.6 Thermal Shutdown

TPS54327 monitors the temperature of itself. If the temperature exceeds the threshold value (typically 165°C), the device is shut off. This is non-latch protection.

7.4 Device Functional Modes

7.4.1 Normal Operation

When the input voltage is above the UVLO threshold and the EN voltage is above the enable threshold, the TPS54327 device operates in normal switching mode. Normal continuous conduction mode (CCM) occurs when the minimum switch current is above 0 A. In CCM, the TPS54327 device operates at a quasi-fixed frequency of 650 kHz.

7.4.2 Forced CCM Operation

When the TPS54327 device is in normal CCM operating mode and switch current falls below 0 A, the device begins operating in forced CCM.

8 Application and Implementation

NOTE

Information in the following applications sections is not part of the TI component specification, and TI does not warrant its accuracy or completeness. TI's customers are responsible for determining suitability of components for their purposes. Customers should validate and test their design implementation to confirm system functionality.

8.1 Application Information

The TPS54327 device is used as a step converter that converts a voltage of 4.5 V to 18 V to a lower voltage. [WEBENCH](#) software is available to aid in the design and analysis of circuits.

8.2 Typical Application

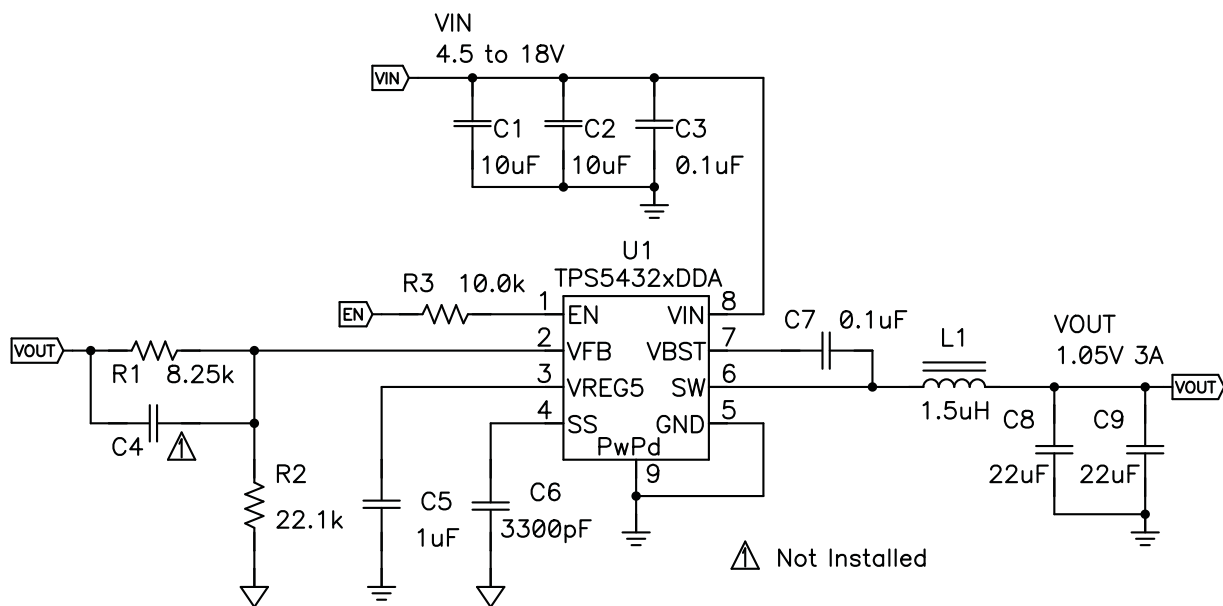

Figure 7. Schematic Diagram

8.2.1 Design Requirements

Use the parameters in [Table 1](#) for this application.

Table 1. TPS54327EVM-686 Performance Specifications Summary

PARAMETERS	TEST CONDITIONS	MIN	TYP	MAX	UNIT
Input voltage range (V_{IN})		4.5	12	18	V
Output voltage			1.05		V
Operating frequency	$V_{IN} = 12\text{ V}$, $I_O = 1\text{ A}$		675		kHz
Output current range		0		3	A

8.2.2 Detailed Design Procedure

To begin the design process, you must know a few application parameters:

- Input voltage range
- Output voltage
- Output current
- Output voltage ripple
- Input voltage ripple

8.2.2.1 Output Voltage Resistors Selection

The output voltage is set with a resistor divider from the output node to the VFB pin. TI recommends using 1% tolerance or better divider resistors. Start by using [Equation 2](#) to calculate V_{OUT} .

To improve efficiency at very light loads consider using larger value resistors, too high of resistance will be more susceptible to noise and voltage errors from the VFB input current will be more noticeable.

$$V_{OUT} = 0.765 \times \left(1 + \frac{R1}{R2} \right) \quad (2)$$

8.2.2.2 Output Filter Selection

The output filter used with the TPS54327 is an LC circuit. This LC filter has double pole at:

$$F_P = \frac{1}{2\pi\sqrt{L_{OUT} \times C_{OUT}}} \quad (3)$$

At low frequencies, the overall loop gain is set by the output set-point resistor divider network and the internal gain of the TPS54327. The low-frequency phase is 180 degrees. At the output filter pole frequency, the gain rolls off at a -40 dB per decade rate and the phase drops rapidly. D-CAP2™ introduces a high-frequency zero that reduces the gain roll off to -20 dB per decade and increases the phase to 90 degrees one decade above the zero frequency. The inductor and capacitor selected for the output filter must be selected so that the double pole of [Equation 3](#) is located below the high-frequency zero but close enough that the phase boost provided by the high-frequency zero provides adequate phase margin for a stable circuit. To meet this requirement use the values recommended in [Table 2](#)

Table 2. Recommended Component Values

OUTPUT VOLTAGE (V)	R1 (kΩ)	R2 (kΩ)	C4 (pF)	L1 (μH)	C8 + C9 (μF)
1	6.81	22.1		1.5	22 to 68
1.05	8.25	22.1		1.5	22 to 68
1.2	12.7	22.1		1.5	22 to 68
1.8	30.1	22.1	5 - 22	2.2	22 to 68
2.5	49.9	22.1	5 - 22	2.2	22 to 68
3.3	73.2	22.1	5 - 22	2.2	22 to 68
5	124	22.1	5 - 22	3.3	22 to 68
6.5	165	22.1	5 - 22	3.3	22 to 68

Because the DC gain is dependent on the output voltage, the required inductor value will increase as the output voltage increases. For higher output voltages above 1.8 V, additional phase boost can be achieved by adding a feed forward capacitor (C4) in parallel with R1

The inductor peak-to-peak ripple current, peak current and RMS current are calculated using [Equation 4](#), [Equation 5](#) and [Equation 6](#). The inductor saturation current rating must be greater than the calculated peak current and the RMS or heating current rating must be greater than the calculated RMS current. Use 700 kHz for f_{SW} .

Use 700 kHz for f_{SW} . Make sure the chosen inductor is rated for the peak current of [Equation 5](#) and the RMS current of [Equation 6](#).

$$I_{IPP} = \frac{V_{OUT}}{V_{IN(max)}} \times \frac{V_{IN(max)} - V_{OUT}}{L_O \times f_{SW}} \quad (4)$$

$$I_{Ipeak} = I_O + \frac{I_{Ipp}}{2} \quad (5)$$

$$I_{Lo(RMS)} = \sqrt{I_O^2 + \frac{1}{12} I_{IPP}^2} \quad (6)$$

For this design example, the calculated peak current is 3.47 A and the calculated RMS current is 3.01 A. The inductor used is a TDK SPM6530-1R5M100 with a peak current rating of 11.5 A and an RMS current rating of 11 A.

The capacitor value and ESR determines the amount of output voltage ripple. The TPS54327 is intended for use with ceramic or other low ESR capacitors. Recommended values range from 22µF to 68µF. Use Equation 7 to determine the required RMS current rating for the output capacitor.

$$I_{Co(RMS)} = \frac{V_{OUT} \times (V_{IN} - V_{OUT})}{\sqrt{12} \times V_{IN} \times L_O \times f_{SW}} \quad (7)$$

For this design two TDK C3216X5R0J226M 22-µF output capacitors are used. The typical ESR is 2 mΩ each. The calculated RMS current is 0.271 A and each output capacitor is rated for 4 A.

8.2.2.3 Input Capacitor Selection

The TPS54327 requires an input decoupling capacitor and a bulk capacitor is needed depending on the application. TI recommends a ceramic capacitor over 10 µF for the decoupling capacitor. TI also recommends connecting an additional 0.1-µF capacitor from pin 14 to ground to improve the stability of the overcurrent limit function. The capacitor voltage rating must be greater than the maximum input voltage.

8.2.2.4 Bootstrap Capacitor Selection

A 0.1 µF ceramic capacitor must be connected between the VBST to SW pin for proper operation. TI recommends using a ceramic capacitor.

8.2.2.5 VREG5 Capacitor Selection

A 1-µF ceramic capacitor must be connected between the VREG5 to GND pin for proper operation. TI recommends using a ceramic capacitor.

8.2.3 Application Curves

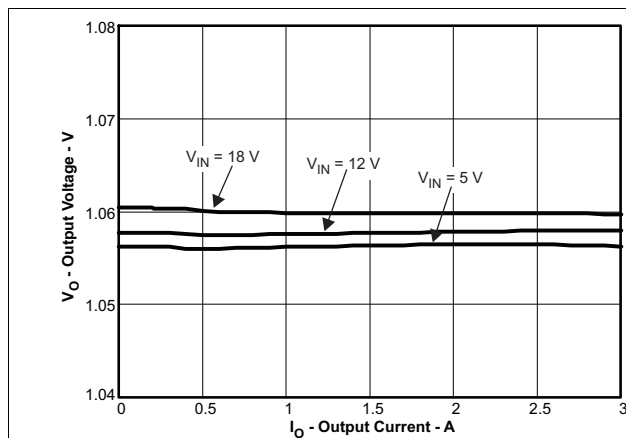

Figure 8. 1.05-V Output Voltage vs Output Current

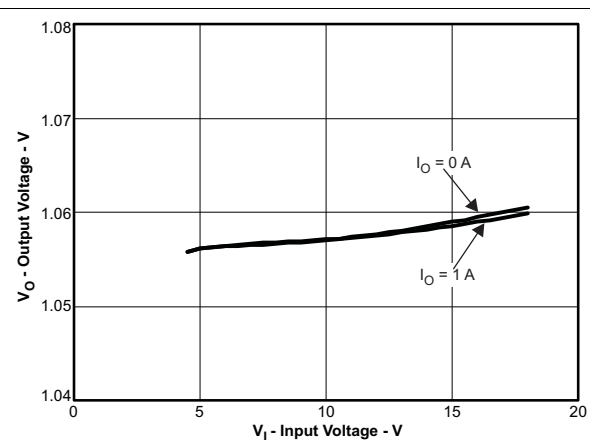

Figure 9. 1.05-V Output Voltage vs Input Voltage

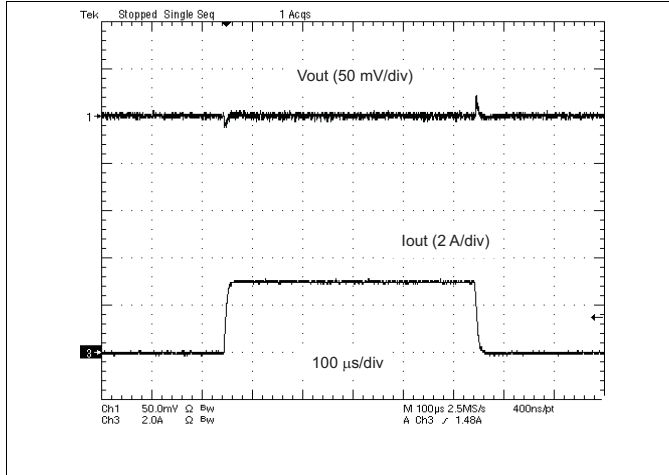

Figure 10. 1.05-V, 0-A to 3-A Load Transient Response

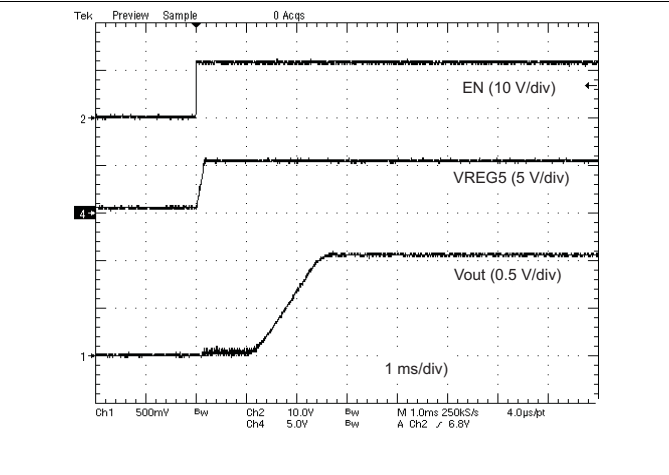

Figure 11. Start-Up Wave Form

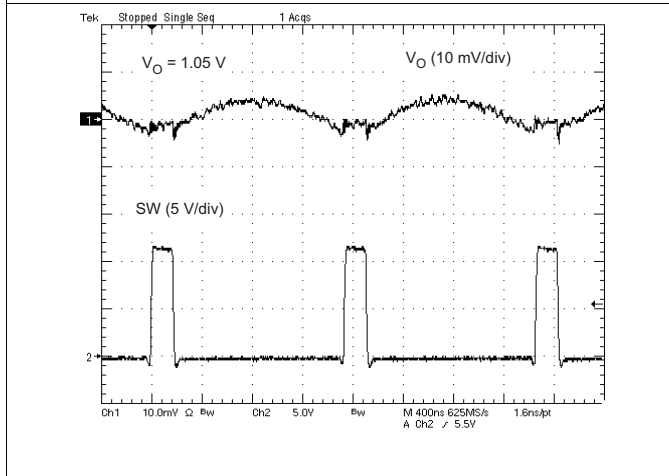

Figure 12. Voltage Ripple at Output ($I_O = 3\text{ A}$)

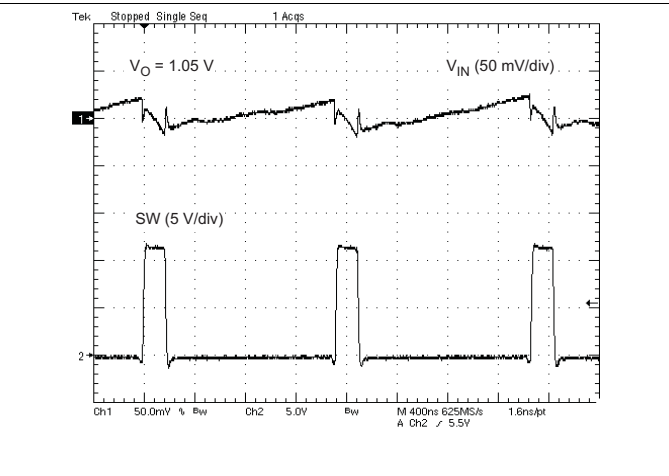

Figure 13. Voltage Ripple at Input ($I_O = 3\text{ A}$)

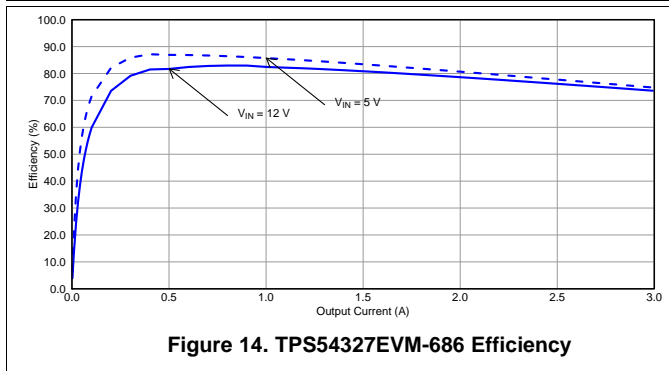

Figure 14. TPS54327EVM-686 Efficiency

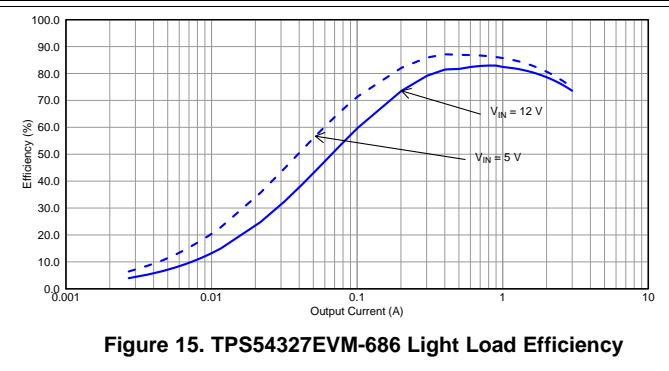

Figure 15. TPS54327EVM-686 Light Load Efficiency

9 Power Supply Recommendations

The TPS54327 device is designed to operate from input supply voltage in the range of 4.5 V to 18 V. Buck converters require the input voltage to be higher than the output voltage. In this case, the maximum recommended operating duty cycle is 65%. Using that criteria, the minimum recommended input voltage is $V_o/0.65$.

10 Layout

10.1 Layout Guidelines

1. Keep the input switching current loop as small as possible.
2. Keep the SW node as physically small and short as possible to minimize parasitic capacitance and inductance and to minimize radiated emissions. Kelvin connections should be brought from the output to the feedback pin of the device.
3. Keep analog and non-switching components away from switching components.
4. Make a single point connection from the signal ground to power ground.
5. Do not allow switching current to flow under the device.
6. Keep the pattern lines for VIN and PGND broad.
7. Exposed pad of device must be connected to PGND with solder.
8. VREG5 capacitor should be placed near the device, and connected PGND.
9. Output capacitor should be connected to a broad pattern of the PGND.
10. Voltage feedback loop should be as short as possible, and preferably with ground shield.
11. Lower resistor of the voltage divider which is connected to the VFB pin should be tied to SGND.
12. Providing sufficient via is preferable for VIN, SW and PGND connection.
13. PCB pattern for VIN, SW, and PGND should be as broad as possible.
14. VIN Capacitor should be placed as near as possible to the device.

10.2 Layout Examples

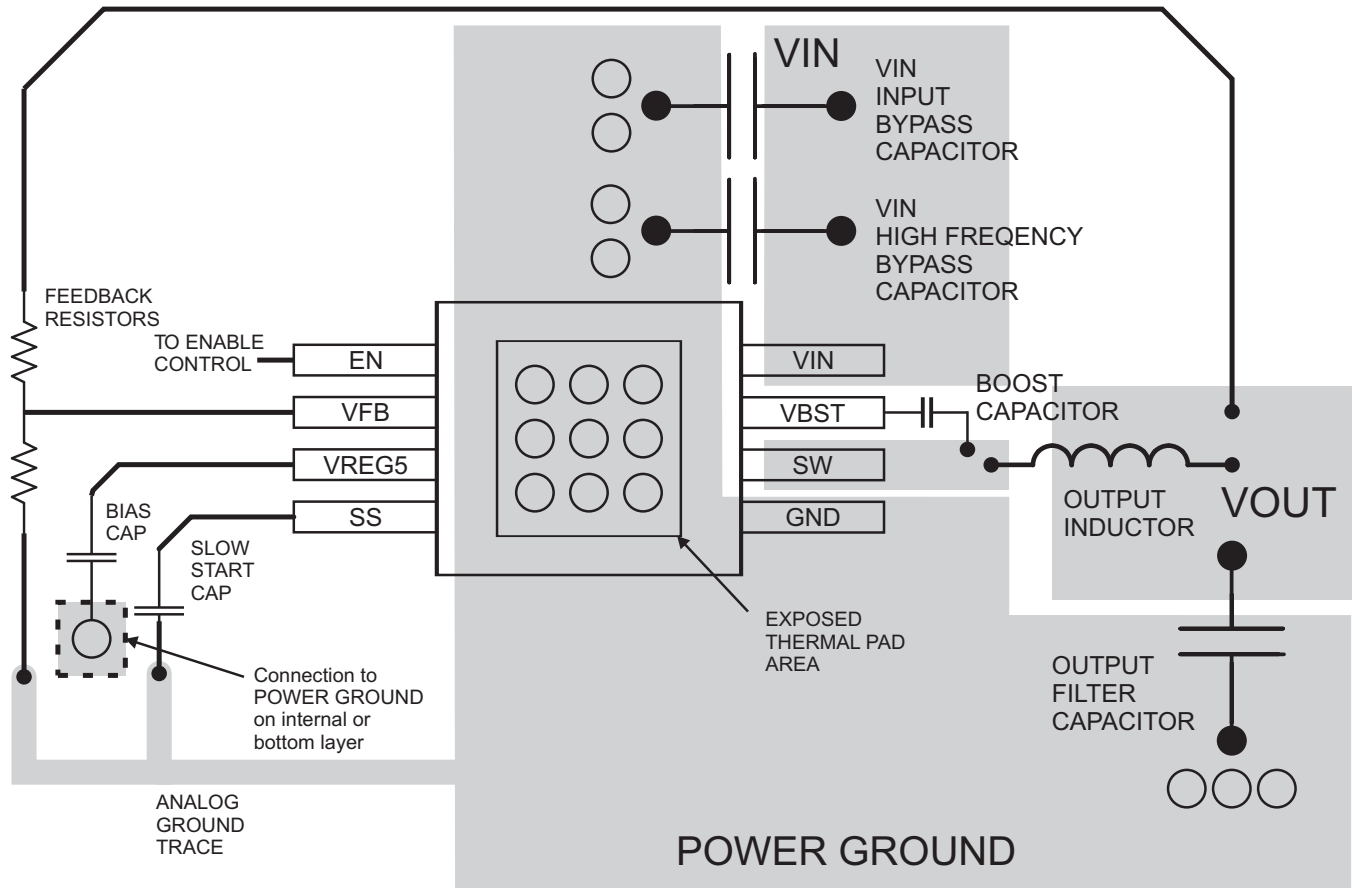

○ VIA to Ground Plane

Figure 16. PCB Layout

Layout Examples (continued)

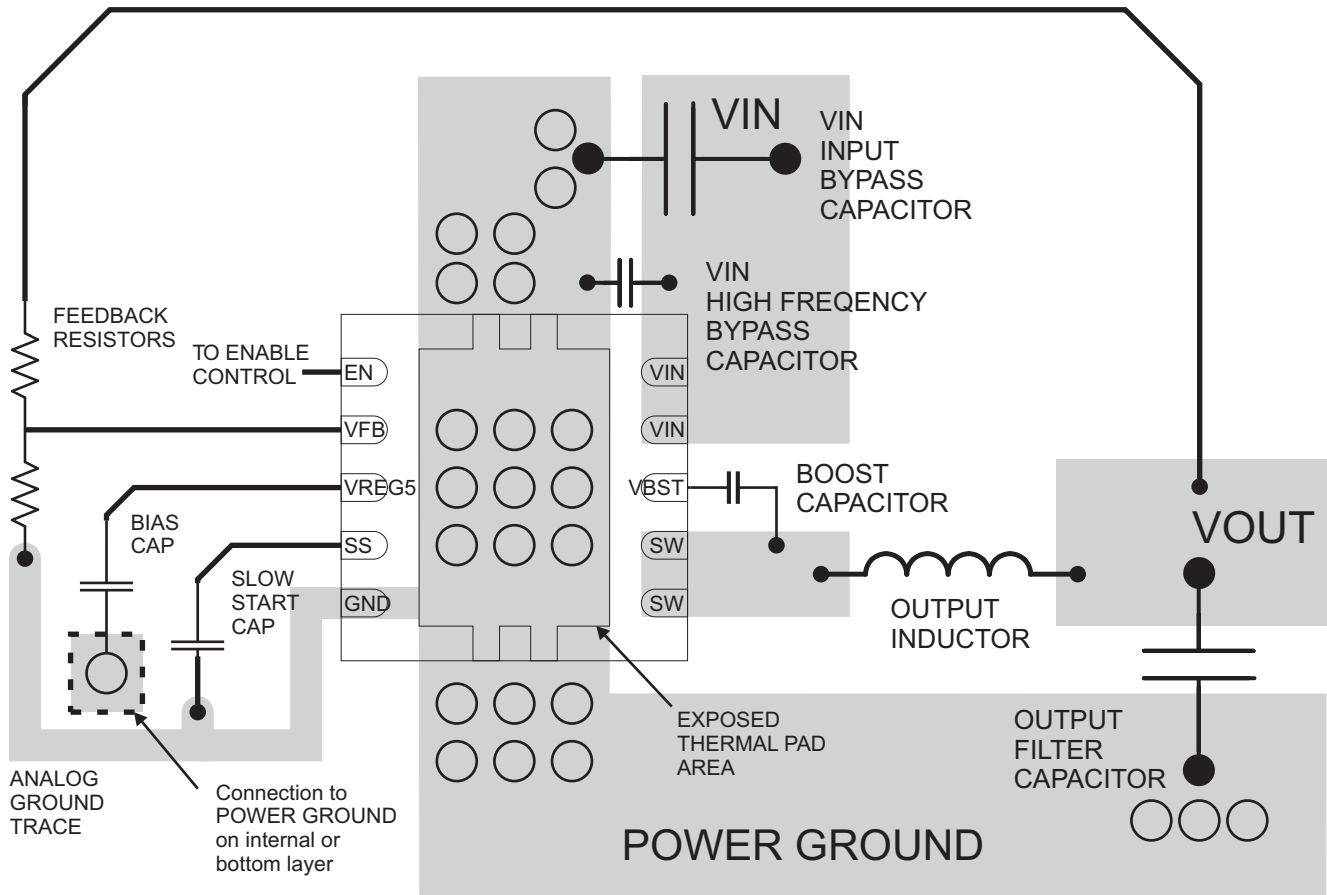

○ VIA to Ground Plane

Figure 17. PCB Layout for the DRC Package

10.3 Thermal Considerations

This 8-pin DDA package incorporates an exposed thermal pad that is designed to be directly attached to an external heatsink. The thermal pad must be soldered directly to the printed-circuit board (PCB). After soldering, the PCB can be used as a heatsink. In addition, through the use of thermal vias, the thermal pad can be attached directly to the appropriate copper plane shown in the electrical schematic for the device, or alternatively, can be attached to a special heatsink structure designed into the PCB. This design optimizes the heat transfer from the integrated circuit (IC).

For additional information on the exposed thermal pad and how to use the advantage of its heat dissipating abilities, see the technical brief, *PowerPAD™ Thermally Enhanced Package (SLMA002)*, and the application brief, *PowerPAD™ Made Easy (SLMA004)*.

The exposed thermal pad dimensions for this package are shown in the following illustration.

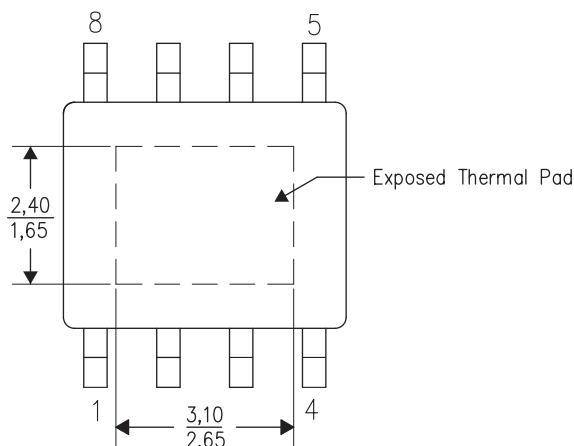

Figure 18. Thermal Pad Dimensions (Top View)

11 Device and Documentation Support

11.1 Documentation Support

11.1.1 Related Documentation

For related documentation see the following:

- *PowerPAD™ Thermally Enhanced Package*, [SLMA002](#)
- *PowerPAD™ Made Easy*, [SLMA004](#)

11.2 Community Resources

The following links connect to TI community resources. Linked contents are provided "AS IS" by the respective contributors. They do not constitute TI specifications and do not necessarily reflect TI's views; see TI's [Terms of Use](#).

TI E2E™ Online Community *TI's Engineer-to-Engineer (E2E) Community*. Created to foster collaboration among engineers. At [e2e.ti.com](#), you can ask questions, share knowledge, explore ideas and help solve problems with fellow engineers.

Design Support *TI's Design Support* Quickly find helpful E2E forums along with design support tools and contact information for technical support.

11.3 Trademarks

D-CAP2, E2E are trademarks of Texas Instruments.
Blu-ray Disc is a trademark of Blu-ray Disc Association.
All other trademarks are the property of their respective owners.

11.4 Electrostatic Discharge Caution



These devices have limited built-in ESD protection. The leads should be shorted together or the device placed in conductive foam during storage or handling to prevent electrostatic damage to the MOS gates.

11.5 Glossary

[SLYZ022](#) — *TI Glossary*.

This glossary lists and explains terms, acronyms, and definitions.

12 Mechanical, Packaging, and Orderable Information

The following pages include mechanical, packaging, and orderable information. This information is the most current data available for the designated devices. This data is subject to change without notice and revision of this document. For browser-based versions of this data sheet, refer to the left-hand navigation.

PACKAGING INFORMATION

Orderable Device	Status (1)	Package Type	Package Drawing	Pins	Package Qty	Eco Plan (2)	Lead/Ball Finish (6)	MSL Peak Temp (3)	Op Temp (°C)	Device Marking (4/5)	Samples
TPS54327DDA	ACTIVE	SO PowerPAD	DDA	8	75	Green (RoHS & no Sb/Br)	CU NIPDAUAG Call TI	Level-2-260C-1 YEAR	-40 to 85	54327	Samples
TPS54327DDAR	ACTIVE	SO PowerPAD	DDA	8	2500	Green (RoHS & no Sb/Br)	CU NIPDAUAG Call TI	Level-2-260C-1 YEAR	-40 to 85	54327	Samples
TPS54327DRCR	ACTIVE	VSON	DRC	10	3000	Green (RoHS & no Sb/Br)	CU NIPDAU	Level-2-260C-1 YEAR	-40 to 85	54327	Samples
TPS54327DRCT	ACTIVE	VSON	DRC	10	250	Green (RoHS & no Sb/Br)	CU NIPDAU	Level-2-260C-1 YEAR	-40 to 85	54327	Samples

(1) The marketing status values are defined as follows:

ACTIVE: Product device recommended for new designs.

LIFEBUY: TI has announced that the device will be discontinued, and a lifetime-buy period is in effect.

NRND: Not recommended for new designs. Device is in production to support existing customers, but TI does not recommend using this part in a new design.

PREVIEW: Device has been announced but is not in production. Samples may or may not be available.

OBSOLETE: TI has discontinued the production of the device.

(2) Eco Plan - The planned eco-friendly classification: Pb-Free (RoHS), Pb-Free (RoHS Exempt), or Green (RoHS & no Sb/Br) - please check <http://www.ti.com/productcontent> for the latest availability information and additional product content details.

TBD: The Pb-Free/Green conversion plan has not been defined.

Pb-Free (RoHS): TI's terms "Lead-Free" or "Pb-Free" mean semiconductor products that are compatible with the current RoHS requirements for all 6 substances, including the requirement that lead not exceed 0.1% by weight in homogeneous materials. Where designed to be soldered at high temperatures, TI Pb-Free products are suitable for use in specified lead-free processes.

Pb-Free (RoHS Exempt): This component has a RoHS exemption for either 1) lead-based flip-chip solder bumps used between the die and package, or 2) lead-based die adhesive used between the die and leadframe. The component is otherwise considered Pb-Free (RoHS compatible) as defined above.

Green (RoHS & no Sb/Br): TI defines "Green" to mean Pb-Free (RoHS compatible), and free of Bromine (Br) and Antimony (Sb) based flame retardants (Br or Sb do not exceed 0.1% by weight in homogeneous material)

(3) MSL, Peak Temp. - The Moisture Sensitivity Level rating according to the JEDEC industry standard classifications, and peak solder temperature.

(4) There may be additional marking, which relates to the logo, the lot trace code information, or the environmental category on the device.

(5) Multiple Device Markings will be inside parentheses. Only one Device Marking contained in parentheses and separated by a "~" will appear on a device. If a line is indented then it is a continuation of the previous line and the two combined represent the entire Device Marking for that device.

(6) Lead/Ball Finish - Orderable Devices may have multiple material finish options. Finish options are separated by a vertical ruled line. Lead/Ball Finish values may wrap to two lines if the finish value exceeds the maximum column width.

Important Information and Disclaimer: The information provided on this page represents TI's knowledge and belief as of the date that it is provided. TI bases its knowledge and belief on information provided by third parties, and makes no representation or warranty as to the accuracy of such information. Efforts are underway to better integrate information from third parties. TI has taken and continues to take reasonable steps to provide representative and accurate information but may not have conducted destructive testing or chemical analysis on incoming materials and chemicals. TI and TI suppliers consider certain information to be proprietary, and thus CAS numbers and other limited information may not be available for release.

In no event shall TI's liability arising out of such information exceed the total purchase price of the TI part(s) at issue in this document sold by TI to Customer on an annual basis.

TAPE AND REEL INFORMATION

QUADRANT ASSIGNMENTS FOR PIN 1 ORIENTATION IN TAPE

*All dimensions are nominal

Device	Package Type	Package Drawing	Pins	SPQ	Reel Diameter (mm)	Reel Width W1 (mm)	A0 (mm)	B0 (mm)	K0 (mm)	P1 (mm)	W (mm)	Pin1 Quadrant
TPS54327DDAR	SO Power PAD	DDA	8	2500	330.0	12.8	6.4	5.2	2.1	8.0	12.0	Q1
TPS54327DRCR	VSON	DRC	10	3000	330.0	12.4	3.3	3.3	1.1	8.0	12.0	Q2
TPS54327DRCT	VSON	DRC	10	250	180.0	12.4	3.3	3.3	1.1	8.0	12.0	Q2

TAPE AND REEL BOX DIMENSIONS

*All dimensions are nominal

Device	Package Type	Package Drawing	Pins	SPQ	Length (mm)	Width (mm)	Height (mm)
TPS54327DDAR	SO PowerPAD	DDA	8	2500	366.0	364.0	50.0
TPS54327DRCR	VSON	DRC	10	3000	367.0	367.0	35.0
TPS54327DRCT	VSON	DRC	10	250	210.0	185.0	35.0

DDA (R-PDSO-G8)

PowerPAD™ PLASTIC SMALL-OUTLINE

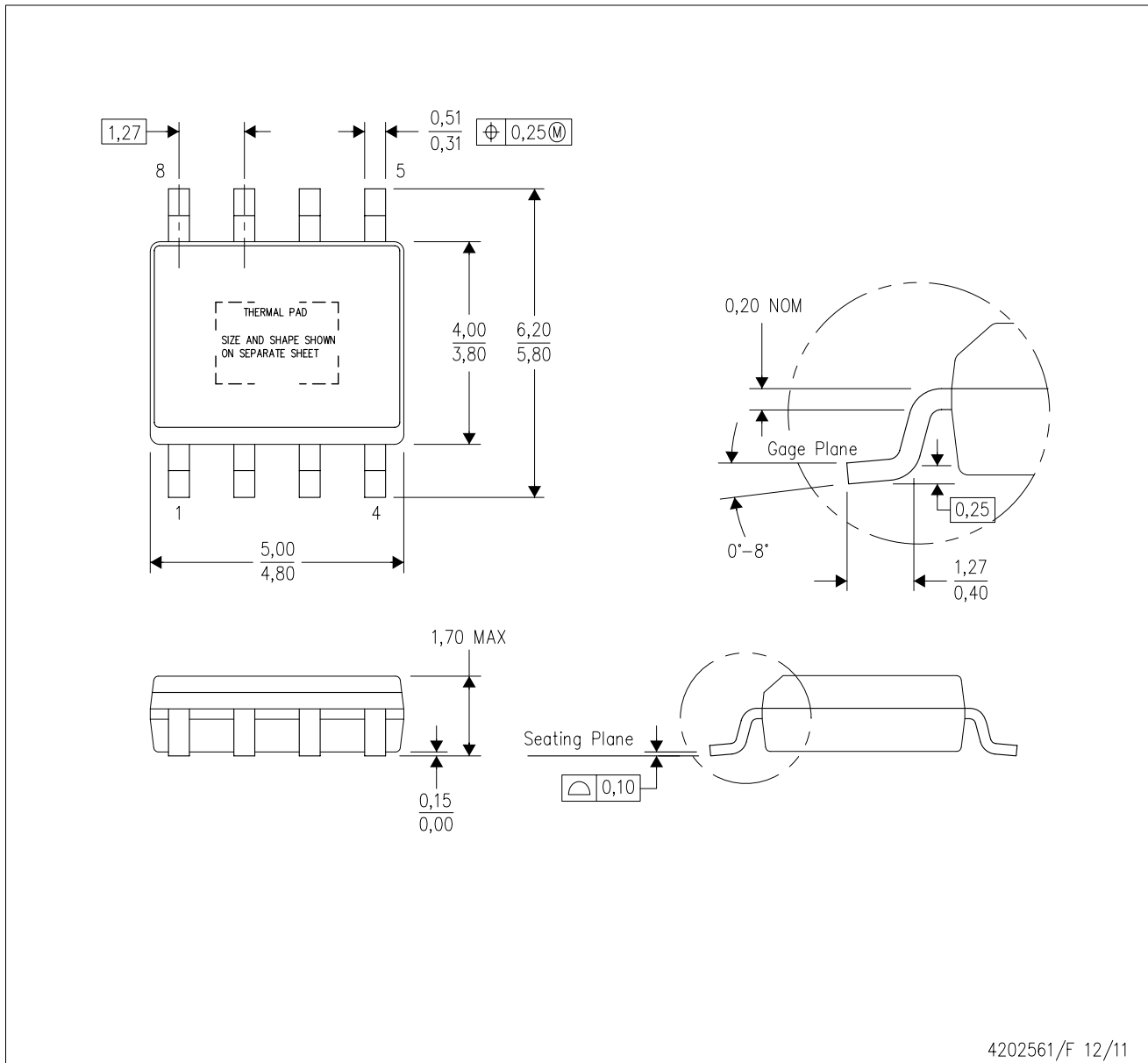

4202561/F 12/11

- NOTES:
- A. All linear dimensions are in millimeters. Dimensioning and tolerancing per ASME Y14.5-1994.
 - B. This drawing is subject to change without notice.
 - C. Body dimensions do not include mold flash or protrusion not to exceed 0,15.
 - D. This package is designed to be soldered to a thermal pad on the board. Refer to Technical Brief, PowerPad Thermally Enhanced Package, Texas Instruments Literature No. SLMA002 for information regarding recommended board layout. This document is available at www.ti.com <<http://www.ti.com>>.
 - E. See the additional figure in the Product Data Sheet for details regarding the exposed thermal pad features and dimensions.
 - F. This package complies to JEDEC MS-012 variation BA

PowerPAD is a trademark of Texas Instruments.

DDA (R-PDSO-G8)

PowerPAD™ PLASTIC SMALL OUTLINE

THERMAL INFORMATION

This PowerPAD™ package incorporates an exposed thermal pad that is designed to be attached to a printed circuit board (PCB). The thermal pad must be soldered directly to the PCB. After soldering, the PCB can be used as a heatsink. In addition, through the use of thermal vias, the thermal pad can be attached directly to the appropriate copper plane shown in the electrical schematic for the device, or alternatively, can be attached to a special heatsink structure designed into the PCB. This design optimizes the heat transfer from the integrated circuit (IC).

For additional information on the PowerPAD package and how to take advantage of its heat dissipating abilities, refer to Technical Brief, PowerPAD Thermally Enhanced Package, Texas Instruments Literature No. SLMA002 and Application Brief, PowerPAD Made Easy, Texas Instruments Literature No. SLMA004. Both documents are available at www.ti.com.

The exposed thermal pad dimensions for this package are shown in the following illustration.



Exposed Thermal Pad Dimensions

4206322-6/L 05/12

NOTE: A. All linear dimensions are in millimeters

PowerPAD is a trademark of Texas Instruments



- NOTES:
- A. All linear dimensions are in millimeters.
 - B. This drawing is subject to change without notice.
 - C. Publication IPC-7351 is recommended for alternate designs.
 - D. This package is designed to be soldered to a thermal pad on the board. Refer to Technical Brief, PowerPad Thermally Enhanced Package, Texas Instruments Literature No. SLMA002, SLMA004, and also the Product Data Sheets for specific thermal information, via requirements, and recommended board layout. These documents are available at www.ti.com <<http://www.ti.com>>. Publication IPC-7351 is recommended for alternate designs.
 - E. Laser cutting apertures with trapezoidal walls and also rounding corners will offer better paste release. Customers should contact their board assembly site for stencil design recommendations. Example stencil design based on a 50% volumetric metal load solder paste. Refer to IPC-7525 for other stencil recommendations.
 - F. Customers should contact their board fabrication site for solder mask tolerances between and around signal pads.

PowerPAD is a trademark of Texas Instruments.

DRC (S-PVSON-N10)

PLASTIC SMALL OUTLINE NO-LEAD



- NOTES:
- All linear dimensions are in millimeters. Dimensioning and tolerancing per ASME Y14.5M-1994.
 - This drawing is subject to change without notice.
 - Small Outline No-Lead (SON) package configuration.
 - The package thermal pad must be soldered to the board for thermal and mechanical performance, if present.
 - See the additional figure in the Product Data Sheet for details regarding the exposed thermal pad features and dimensions, if present

THERMAL PAD MECHANICAL DATA

DRC (S-PVSON-N10)

PLASTIC SMALL OUTLINE NO-LEAD

THERMAL INFORMATION

This package incorporates an exposed thermal pad that is designed to be attached directly to an external heatsink. The thermal pad must be soldered directly to the printed circuit board (PCB). After soldering, the PCB can be used as a heatsink. In addition, through the use of thermal vias, the thermal pad can be attached directly to the appropriate copper plane shown in the electrical schematic for the device, or alternatively, can be attached to a special heatsink structure designed into the PCB. This design optimizes the heat transfer from the integrated circuit (IC).

For information on the Quad Flatpack No-Lead (QFN) package and its advantages, refer to Application Report, QFN/SON PCB Attachment, Texas Instruments Literature No. SLUA271. This document is available at www.ti.com.

The exposed thermal pad dimensions for this package are shown in the following illustration.

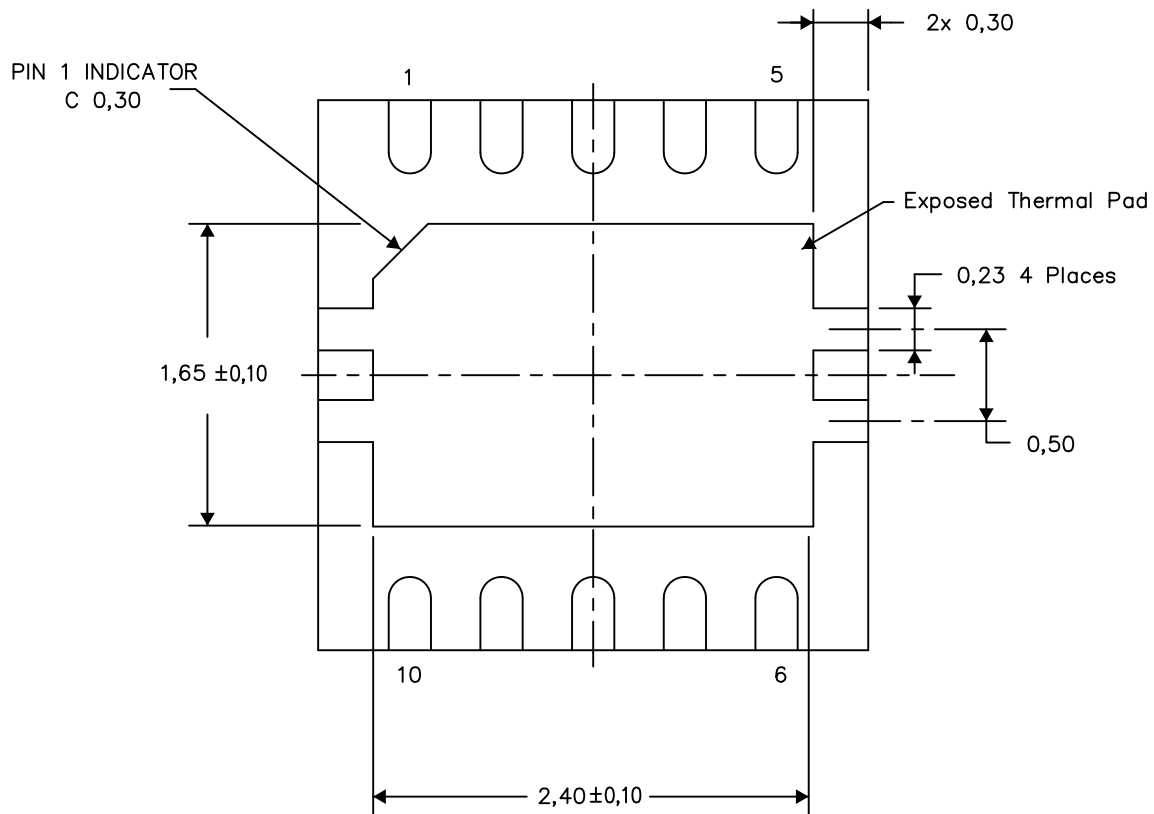

Bottom View

Exposed Thermal Pad Dimensions

4206565-3/Y 08/15

NOTE: A. All linear dimensions are in millimeters

DRC (S-PVSON-N10)

PLASTIC SMALL OUTLINE NO-LEAD

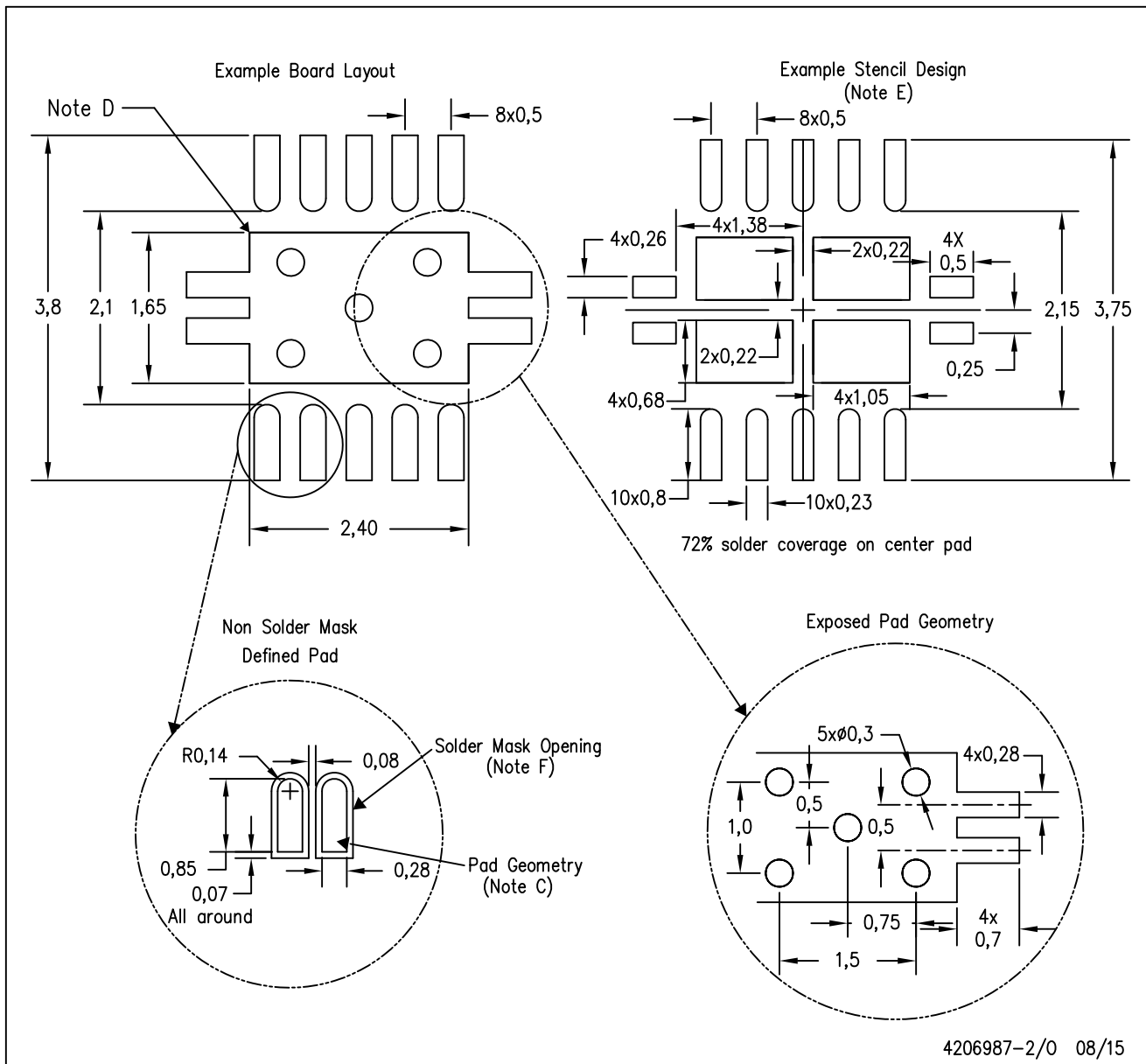

- NOTES:
- All linear dimensions are in millimeters.
 - This drawing is subject to change without notice.
 - Publication IPC-7351 is recommended for alternate designs.
 - This package is designed to be soldered to a thermal pad on the board. Refer to Application Note, Quad Flat-Pack Packages, Texas Instruments Literature No. SLUA271, and also the Product Data Sheets for specific thermal information, via requirements, and recommended board layout. These documents are available at www.ti.com <<http://www.ti.com>>.
 - Laser cutting apertures with trapezoidal walls and also rounding corners will offer better paste release. Customers should contact their board assembly site for stencil design recommendations. Refer to IPC 7525 for stencil design considerations.
 - Customers should contact their board fabrication site for minimum solder mask web tolerances between signal pads.

IMPORTANT NOTICE

Texas Instruments Incorporated and its subsidiaries (TI) reserve the right to make corrections, enhancements, improvements and other changes to its semiconductor products and services per JESD46, latest issue, and to discontinue any product or service per JESD48, latest issue. Buyers should obtain the latest relevant information before placing orders and should verify that such information is current and complete. All semiconductor products (also referred to herein as "components") are sold subject to TI's terms and conditions of sale supplied at the time of order acknowledgment.

TI warrants performance of its components to the specifications applicable at the time of sale, in accordance with the warranty in TI's terms and conditions of sale of semiconductor products. Testing and other quality control techniques are used to the extent TI deems necessary to support this warranty. Except where mandated by applicable law, testing of all parameters of each component is not necessarily performed.

TI assumes no liability for applications assistance or the design of Buyers' products. Buyers are responsible for their products and applications using TI components. To minimize the risks associated with Buyers' products and applications, Buyers should provide adequate design and operating safeguards.

TI does not warrant or represent that any license, either express or implied, is granted under any patent right, copyright, mask work right, or other intellectual property right relating to any combination, machine, or process in which TI components or services are used. Information published by TI regarding third-party products or services does not constitute a license to use such products or services or a warranty or endorsement thereof. Use of such information may require a license from a third party under the patents or other intellectual property of the third party, or a license from TI under the patents or other intellectual property of TI.

Reproduction of significant portions of TI information in TI data books or data sheets is permissible only if reproduction is without alteration and is accompanied by all associated warranties, conditions, limitations, and notices. TI is not responsible or liable for such altered documentation. Information of third parties may be subject to additional restrictions.

Resale of TI components or services with statements different from or beyond the parameters stated by TI for that component or service voids all express and any implied warranties for the associated TI component or service and is an unfair and deceptive business practice. TI is not responsible or liable for any such statements.

Buyer acknowledges and agrees that it is solely responsible for compliance with all legal, regulatory and safety-related requirements concerning its products, and any use of TI components in its applications, notwithstanding any applications-related information or support that may be provided by TI. Buyer represents and agrees that it has all the necessary expertise to create and implement safeguards which anticipate dangerous consequences of failures, monitor failures and their consequences, lessen the likelihood of failures that might cause harm and take appropriate remedial actions. Buyer will fully indemnify TI and its representatives against any damages arising out of the use of any TI components in safety-critical applications.

In some cases, TI components may be promoted specifically to facilitate safety-related applications. With such components, TI's goal is to help enable customers to design and create their own end-product solutions that meet applicable functional safety standards and requirements. Nonetheless, such components are subject to these terms.

No TI components are authorized for use in FDA Class III (or similar life-critical medical equipment) unless authorized officers of the parties have executed a special agreement specifically governing such use.

Only those TI components which TI has specifically designated as military grade or "enhanced plastic" are designed and intended for use in military/aerospace applications or environments. Buyer acknowledges and agrees that any military or aerospace use of TI components which have **not** been so designated is solely at the Buyer's risk, and that Buyer is solely responsible for compliance with all legal and regulatory requirements in connection with such use.

TI has specifically designated certain components as meeting ISO/TS16949 requirements, mainly for automotive use. In any case of use of non-designated products, TI will not be responsible for any failure to meet ISO/TS16949.

Products

Audio	www.ti.com/audio
Amplifiers	amplifier.ti.com
Data Converters	dataconverter.ti.com
DLP® Products	www.dlp.com
DSP	dsp.ti.com
Clocks and Timers	www.ti.com/clocks
Interface	interface.ti.com
Logic	logic.ti.com
Power Mgmt	power.ti.com
Microcontrollers	microcontroller.ti.com
RFID	www.ti-rfid.com
OMAP Applications Processors	www.ti.com/omap
Wireless Connectivity	www.ti.com/wirelessconnectivity

Applications

Automotive and Transportation	www.ti.com/automotive
Communications and Telecom	www.ti.com/communications
Computers and Peripherals	www.ti.com/computers
Consumer Electronics	www.ti.com/consumer-apps
Energy and Lighting	www.ti.com/energy
Industrial	www.ti.com/industrial
Medical	www.ti.com/medical
Security	www.ti.com/security
Space, Avionics and Defense	www.ti.com/space-avionics-defense
Video and Imaging	www.ti.com/video

TI E2E Community

e2e.ti.com