

Thermopile Infrared Detectors

Thermopile Detector **TPS 535**

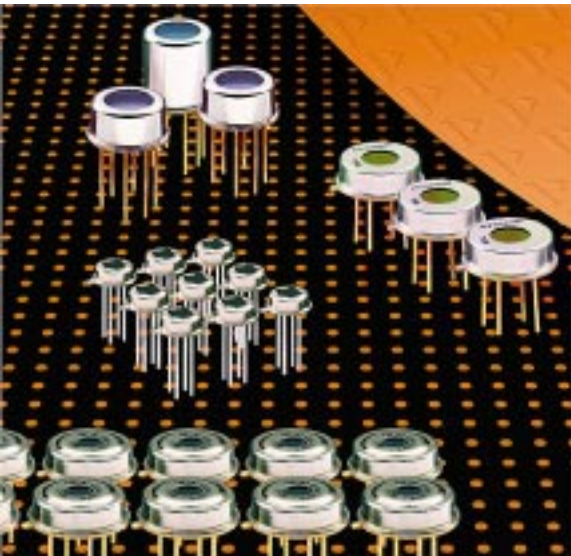

Large absorber size – high signal output

Thermistor temperature reference included

Low temperature coefficient of sensitivity

Applications: ear thermometer, gas detectors (with additional infrared bandpass filter)

The **TPS 535** thermopile sensor in TO 5 type housing employs a chip of 1.2 x 1.2 mm² absorber size and a 30 kΩ thermistor as temperature reference. The square window opening is equipped with a 5.5 μm longpass (standard) infrared filter. The sensor shows a flat sensitivity characteristics over the wavelength.

The **TPS 535** can also be equipped with infrared bandpass filters for NDIR gas detection.

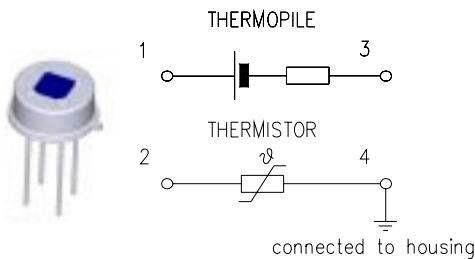

Parameters	TPS 535	typical	units	condition
Sensitive area	1.2 x 1.2		mm ²	absorbing area
Window size	3.5x3.5		mm	
DC sensitivity	20		V/W	500K BB 5..14μm
Resistance	40		kΩ	
Noise	25		nV/√Hz	r.m.s. 300K,
NEP	1.26		nW/√Hz	500K BB 5..14μm
D*	0.96 x 10 ⁸		cm√Hz/W	500K BB 5..14μm
TC of sensitivity	-0.01		%/K	
TC of resistance	0.02		%/K	
Time constant	35		ms	
Storage temperature	-40	100	°C	non permanent
Operating temperature	-40	100	°C	non permanent
Thermistor resistance	30		kΩ	25°C
beta	3964		K	25°C/100°C
Field of view	80		°	at 50% points

Right for modification reserved / WS 1, 122.11.2001

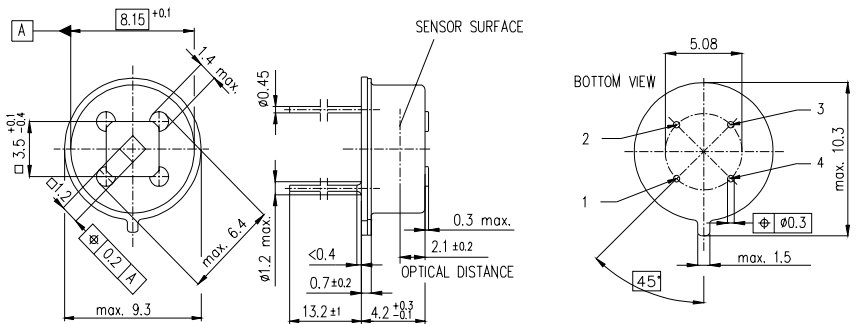
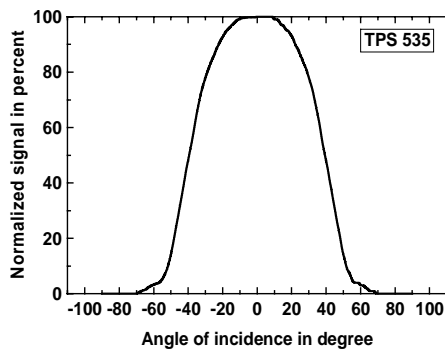
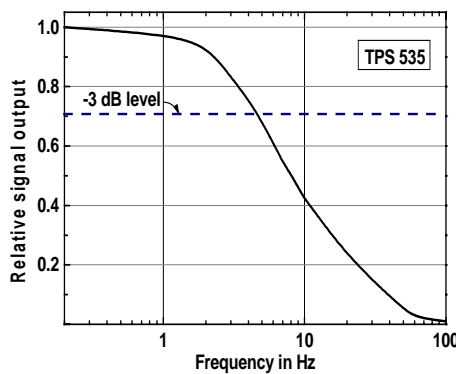

Dimensions in mm

Europe:
PerkinElmer Optoelectronics GmbH
 Wenzel Jaksch Str 31
 Wiesbaden / Germany
 Phone +49(0)611 492 0
 Fax +49(0)611 492 170

USA:
PerkinElmer Optoelectronics
 2175 Mission College Blvd
 Santa Clara, CA 95054
 Phone +408 565 0830
 Fax +408 565 0703

Asia:
PerkinElmer Optoelectronics
 47, Ayer Rajah Crescent #06-12
 Singapore 139947
 Phone +65 775 2022
 Fax +65 775 1008

