

22-V Input, 12-A Integrated FET Converter With Ultra-Low Quiescent (ULQ™)

Check for Samples: [TPS51367](#)

FEATURES

- Input Voltage Range: 3 V to 22 V
- Output Voltage Range: 0.6 V to 2 V
- 12-A Integrated FET Converter
- Fewest External Components
- **ULQ™-100 Mode of Operation to Enable Long Battery Life During System Standby**
- **Soft-Start Time Programmable by External Capacitor**
- **Switching Frequency: 400 kHz and 800 kHz**
- **D-CAP2™ Architecture to Enable POSCAP and All MLCC Output Capacitor Usage**
- **Integrated and Temperature Compensated Low-Side On-Resistance Sensing for Accurate OCL Protection**
- **Powergood Output OCL, OVP, UVP and UVLO Protections**
- **Thermal Shutdown (non-latch)**
- **Output Discharge Function**
- **Integrated Boost MOSFET Switch**
- **28-Pin, 3.5-mm × 4.5-mm, RVE, QFN Package with 0.4-mm Pitch and 1-mm Height**

APPLICATIONS

- **Notebook Computers (VCCIO)**
- **Memory Rails (DDR VDDQ)**

DESCRIPTION

The TPS51367 is a high-voltage input, synchronous converter with integrated FET, based on DCAP-2™ control topology, which enables fast transient response and supports both POSCAP and all MLCC output capacitors. TI proprietary FET technology combined with TI leading-edge package technology provides the highest density solution for single-output power rail such as VCCIO and VDDQ for DDR notebook memory, or any point-of-load (POL) in wide application.

The key feature of the TPS51367 is its ULQ™ Mode to enable low-bias current (100 μ A in low power mode, enabled by LP#). This feature is extremely beneficial for long battery life in system standby mode.

The feature set includes switching frequency of 800 kHz. Programmable soft-start time with an external capacitor. auto skip, pre-bias startup, integrated bootstrap switch, power good, enable and a full suite of fault protection schemes, including OCL, UVP, OVP, 5-V UVLO and thermal shutdown.

It is packaged in 3.5 mm × 4.5 mm, 0.4-mm pitch, 28-pin QFN (RVE), and specified from -10°C to 85°C.

SIMPLIFIED APPLICATION

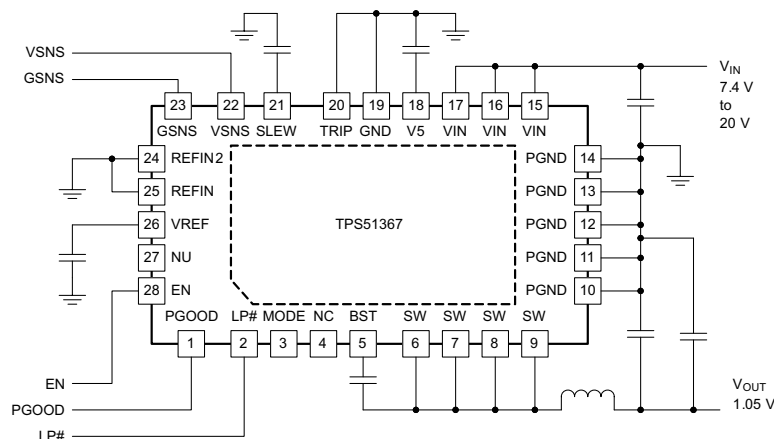

Please be aware that an important notice concerning availability, standard warranty, and use in critical applications of Texas Instruments semiconductor products and disclaimers thereto appears at the end of this data sheet.

ULQ, DCAP-2 are trademarks of Texas Instruments.



These devices have limited built-in ESD protection. The leads should be shorted together or the device placed in conductive foam during storage or handling to prevent electrostatic damage to the MOS gates.

ORDERING INFORMATION^{(1) (2)}

T _A	PACKAGE	ORDERABLE DEVICE NUMBER	PINS	TRANSPORT MEDIA	MINIMUM ORDER QUANTITY
-10°C to 85°C	Plastic Quad Flat Pack (QFN)	TPS51367RVET	28	Small tape-and-reel	250
		TPS51367RVER		Large tape-and-reel	3000

- (1) For the most current package and ordering information, see the Package Option Addendum at the end of this document, or visit the TI website at www.ti.com.
- (2) Package drawings, standard packing quantities, thermal data, symbolization, and PCB design guidelines are available at www.ti.com/sc/package.

ABSOLUTE MAXIMUM RATINGS⁽¹⁾

over operating free-air temperature range (unless otherwise noted)

		VALUE		UNIT
		MIN	MAX	
Input voltage range ⁽²⁾	VIN	-0.3	30	V
	BST		36	
		transient <10 ns	38	
		w/r/t SW	6	
	SW	30		
	EN, TRIP, NU, MODE, V5, LP#	-0.3	6	
	SLEW, VSNS, REFIN, REFIN2	-0.3	3.6	
	GSNS	-0.35	0.35	
PGND	-0.3	0.3		
Output voltage range ⁽²⁾	PGOOD	-0.3	6	V
	VREF	-0.3	3.6	
	NC	-5	36	
Electrostatic discharge	Human body model (HBM) QSS 009-105 (JESD22-A114A)		2000	V
	Charged device model (CDM) QSS 009-147 (JESD22-C101B.01)		500	
Junction temperature range, T _J		-10	150	°C
Storage temperature range, T _{stg}		-55	150	

- (1) Stresses beyond those listed under *Absolute Maximum Ratings* may cause permanent damage to the device. These are stress ratings only and functional operation of the device at these or any other conditions beyond those indicated under *Recommended Operating Conditions* is not implied. Exposure to absolute-maximum-rated conditions for extended periods may affect device reliability.
- (2) All voltage values are with respect to the network ground terminal unless otherwise noted.

THERMAL INFORMATION

THERMAL METRIC ⁽¹⁾		TPS51367	UNITS
		QFN (RVE) (28 PINS)	
θ_{JA}	Junction-to-ambient thermal resistance	40.2	°C/W
θ_{JCTop}	Junction-to-case (top) thermal resistance	22.8	
θ_{JB}	Junction-to-board thermal resistance	20.1	
Ψ_{JT}	Junction-to-top characterization parameter	1.6	
Ψ_{JB}	Junction-to-board characterization parameter	19.4	
θ_{JCbot}	Junction-to-case (bottom) thermal resistance	2.2	

(1) For more information about traditional and new thermal metrics, see the *IC Package Thermal Metrics* application report, [SPRA953](#).

RECOMMENDED OPERATING CONDITIONS

over operating free-air temperature range (unless otherwise noted)

		MIN	MAX	UNIT	
Supply voltage range	VIN	3	22	V	
	V5	4.6	5.5		
Input voltage range	BST	-0.1	33.5		
	SW	-3	27		
	EN, TRIP, NU, MODE, LP#	-0.1	5.5		
	SLEW, VSNS, REFIN, REFIN2	-0.1	3.5		
	GSNS	-0.1	0.3		
	PGND	-0.1	0.1		
Output voltage range	PGOOD	-0.1	5.5		
	VREF, SLEW	-0.1	3.5		
Operating free-air temperature, T _A		-10	85		°C

ELECTRICAL CHARACTERISTICS

over operating free-air temperature range, $V_{IN} = 12\text{ V}$, $V_{V5} = 5\text{ V}$, $\text{MODE} = \text{GND}$, $V_{EN} = 3.3\text{ V}$ (unless otherwise noted)

PARAMETER		TEST CONDITION	MIN	TYP	MAX	UNIT
SUPPLY CURRENT						
I_{V5}	V5 supply current	$T_A = 25^\circ\text{C}$, No load, $V_{EN} = 5\text{ V}$, LP # = 0 V		100		μA
		$T_A = 25^\circ\text{C}$, No load, $V_{EN} = 5\text{ V}$		560		
I_{V5SDN}	V5 shutdown current	$T_A = 25^\circ\text{C}$, No load, $V_{EN} = 0\text{ V}$		1		μA
VREF OUTPUT						
V_{VREF}	Reference voltage	$I_{VREF} = 30\text{ }\mu\text{A}$, w.r.t. GSNS		2		V
		$0\text{ }\mu\text{A} \leq I_{VREF} \leq 300\text{ }\mu\text{A}$, $-10^\circ\text{C} \leq T_A \leq 85^\circ\text{C}$		-1%	1%	
$I_{VREF(OC)}$	Current limit	$(V_{VREF} - V_{GSNS}) = 1.7\text{ V}$	0.4	1		mA
VOLTAGE AMPLIFIER						
I_{VSNS}	VSNS input current	$V_{VSNS} = 1\text{ V}$	-1		1	μA
$I_{VSNS(DIS)}$	VSNS discharge current	$V_{EN} = 0\text{ V}$, $V_{VSNS} = 0.5\text{ V}$		12		mA
SMPS FREQUENCY						
$t_{OFF(min)}$	Minimum off-time			320		ns
t_{DEAD1}	Deadtime1 ⁽¹⁾	SW rising to falling		10		ns
t_{DEAD2}	Deadtime2 ⁽¹⁾	SW falling to rising		10		ns
INTERNAL BOOT STRAP SW						
V_{FBST}	Forward foltage	$V_{V5} - B_{ST}$, $T_A = 25^\circ\text{C}$, $I_F = 10\text{ mA}$		0.1	0.2	V
I_{BST}	BST leakage current	$T_A = 25^\circ\text{C}$, $V_{BST} = 14\text{ V}$, $V_{SW} = 7\text{ V}$		0.01	1.5	μA
MOSFET ON-RESISTANCE						
$R_{DS(on)H}$	High-side on-resistance	$T_A = 25^\circ\text{C}$, $V_{V5} = 5\text{ V}$			15	$\text{m}\Omega$
$R_{DS(on)L}$	Low-side on-resistance	$T_A = 25^\circ\text{C}$, $V_{V5} = 5\text{ V}$			7.5	$\text{m}\Omega$
LOGIC THRESHOLD						
$V_{MODE(TH)}$	MODE threshold voltage	MODE = FLOAT		2.5		V
V_{LL}	EN low-level voltage				0.35	V
V_{LH}	EN high-level voltage		0.9			V
$V_{L(HYST)}$	EN hysteresis voltage			0.25		V
$V_{L(LK)}$	EN input leakage current		-1	0	1	μA
V_{LL}	LP# low-level voltage				0.35	V
V_{LH}	LP# high-level voltage		0.85			V
$V_{L(HYST)}$	LP# hysteresis voltage			0.4		V
$V_{L(LK)}$	LP# input leakage current		-1	0	1	μA
SOFT-START						
I_{SS}	Soft-Start current	Soft-start current source		10		μA
PGOOD COMPARATOR						
V_{PGTH}	PGOOD threshold	PGOOD in from lower (startup)		92%		
I_{PG}	PGOOD sink current	$V_{PGOOD} = 0.5\text{ V}$		6		mA
$t_{PG(CMPSS)}$	PGOOD start-up delay	PGOOD comparator startup delay		1.5		ms
$I_{PG(LK)}$	PGOOD leakage current		-1	0	1	μA

(1) Ensured by design.

ELECTRICAL CHARACTERISTICS (continued)

 over operating free-air temperature range, $V_{IN} = 12\text{ V}$, $V_{V5} = 5\text{ V}$, MODE = GND, $V_{EN} = 3.3\text{ V}$ (unless otherwise noted)

PARAMETER		TEST CONDITION	MIN	TYP	MAX	UNIT
OVERCURRENT LIMIT LEVEL						
I_{OCL}	Current limit threshold	$V_{TRIP} = 0\text{ V}$, valley current set point, $T_A = 25^\circ\text{C}$	7	8	9	A
		$V_{TRIP} = 5\text{ V}$, valley current set point, $T_A = 25^\circ\text{C}$	10.5	12.0	13.5	
		$V_{TRIP} = \text{FLOAT}$, valley current set point, $T_A = 25^\circ\text{C}$	14	16	18	
$V_{ZC}^{(2)}$	Zero cross detection offset		0			mV
PROTECTIONS						
V_{POR}	V5 POR threshold voltage ⁽²⁾	Reset OVP fault		1.7		V
V_{PORHYS}	V5 POR threshold voltage hysteresis ⁽²⁾	Reset OVP fault hysteresis		85		mV
V_{UVLO}	V5 UVLO threshold voltage	Wake-up	4.3	4.4	4.6	V
		Shutdown	3.8	4	4.2	
V_{OVP}	OVP threshold voltage	OVP detect voltage	118%	120%	123%	
t_{OVPDLY}	OVP propagation delay	With 100 mV overdrive		430		ns
V_{OOB}	OOB threshold voltage		105.5%		109.5%	
V_{UVP}	UVP threshold voltage	UVP detect voltage	63%	66%	69%	
t_{UVPDLY}	UVP delay			1		ms
THERMAL SHUTDOWN						
T_{SDN}	Thermal shutdown threshold ⁽²⁾	Shutdown temperature		140		°C
		Hysteresis		10		

(2) Ensured by design.

DEVICE INFORMATION

RVE PACKAGE 28 PINS (TOP VIEW)

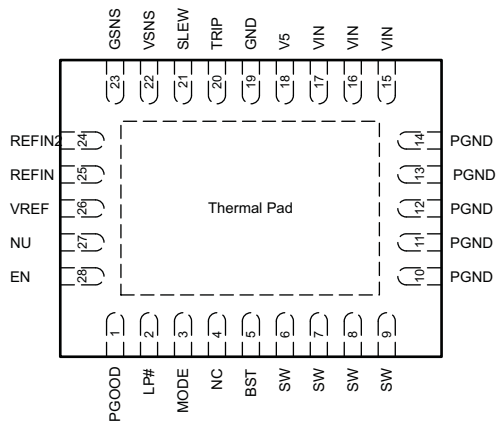

PIN FUNCTIONS

NAME	NO.	I/O/P ⁽¹⁾	DESCRIPTION
BST	5	I	Power supply for internal high side MOSFET. Connect a 0.1- μ F bootstrap capacitor between this pin and SW pin.
EN	28	I	Enable signal, 1.05-V logic compatible.
GND	19	—	General device ground.
GSNS	23	O	GND sense input. Connect GSNS to general/system ground or GND sensing point at the output return.
LP#	2	I	Low power signal (active low) to indicate the converter entering ULQ™ mode. 1.05-V logic compatible.
MODE	3	I	Frequency (400 kHz and 800 kHz) programmable input (see Table 2).
NC	4	—	Not connected.
NU	27	—	Not used for external applications.
PGND	10	—	Power ground. Connect to the system ground.
	11		
	12		
	13		
	14		
PGOOD	1	O	PGOOD output. Connect a pull-up resistor with a value of 100 k Ω to this pin.
Power PAD	29	—	Connect to system ground by multiple vias.
REFIN	25	I	Target output voltage input pin. 0.6 V to 2 V, 1.05 V/1.2 V built-in (GND and Open) (see Table 1).
REFIN2	24	I	Tie to GND or FLOAT. This input is used to determine the fixed voltage setpoint (see Table 1).
SLEW	21	O	Connect a capacitor between this pin and GND for soft start and integrator functions.
SW	6	O	Switching node output. Connect external inductor.
	7		
	8		
	9		
TRIP	20	I	OCL programmable input (see Table 3).
V5	18	I	5-V power supply for analog circuits and gate driver.
VIN	15	I	Power supply input pin. Apply 3-V to 22-V of supply voltage.
	16	I	
	17	I	
VREF	26	O	2-V reference output. Connect a 0.1- μ F ceramic capacitor between this pin and the GNDS pin.
VSNS	22	I	Output voltage sense input.
Power PAD	Connect to system ground by multiple vias.		

(1) I = Input, O = Output, P = Power, G = Ground

FUNCTIONAL BLOCK DIAGRAM

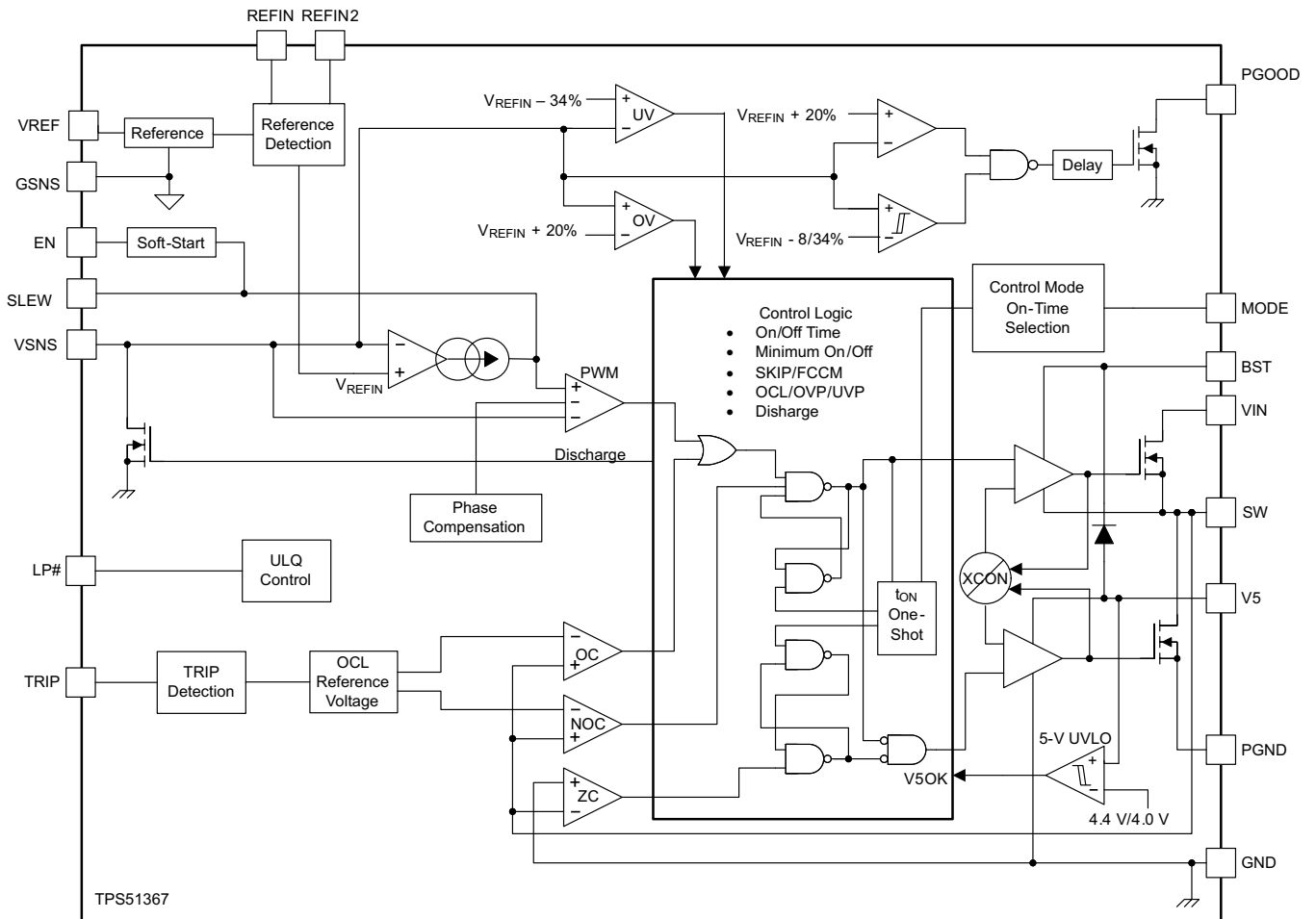

TYPICAL CHARACTERISTICS

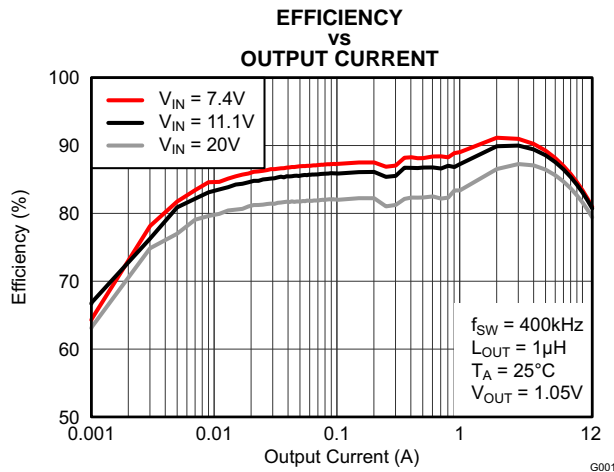

Figure 1.

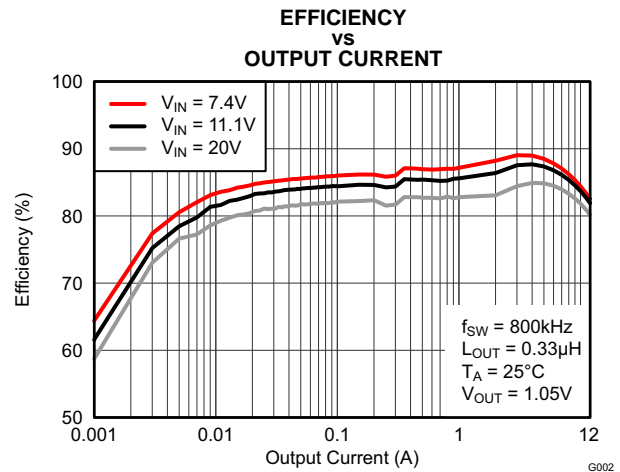

Figure 2.

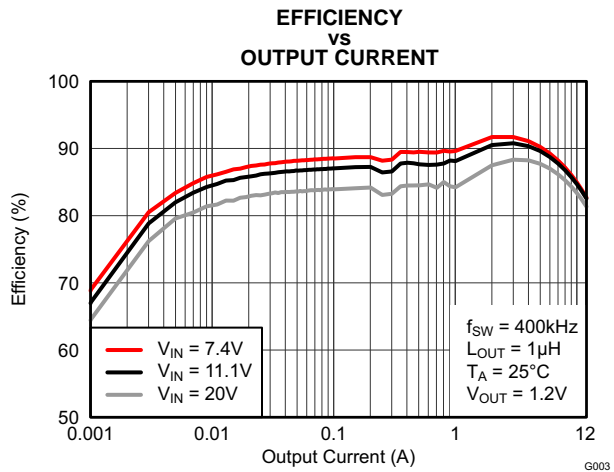

Figure 3.

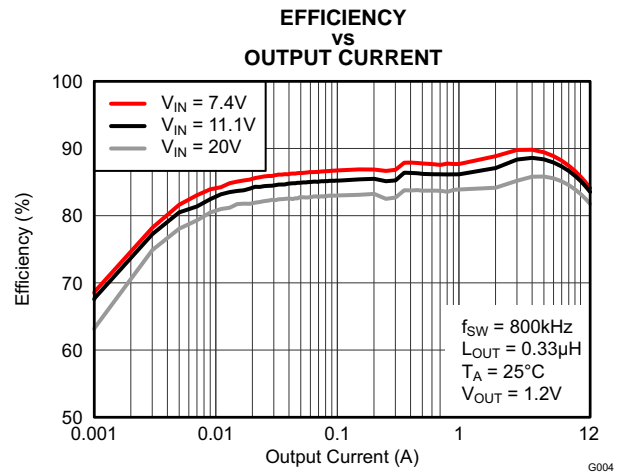

Figure 4.

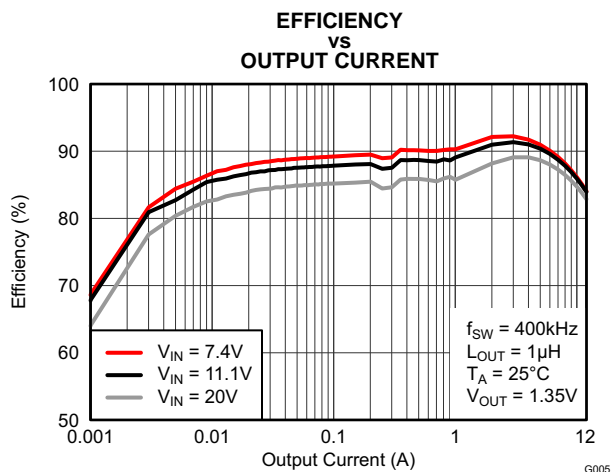

Figure 5.

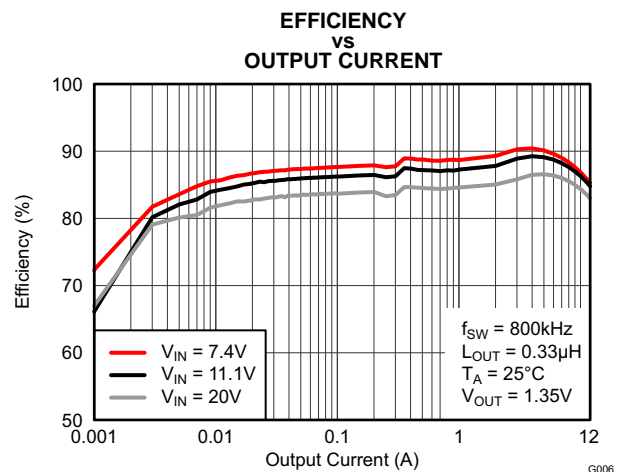

Figure 6.

TYPICAL CHARACTERISTICS (continued)

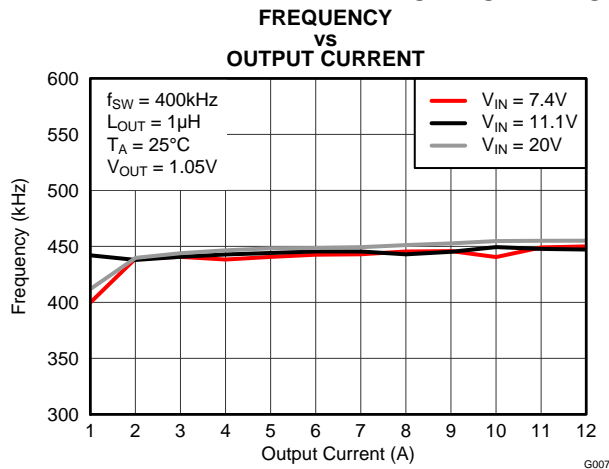

Figure 7.

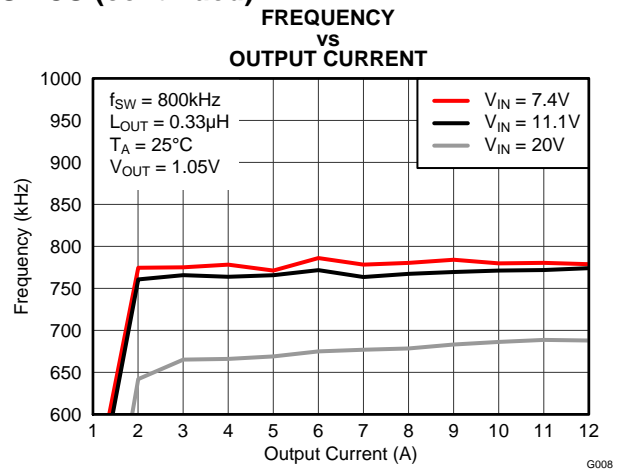

Figure 8.

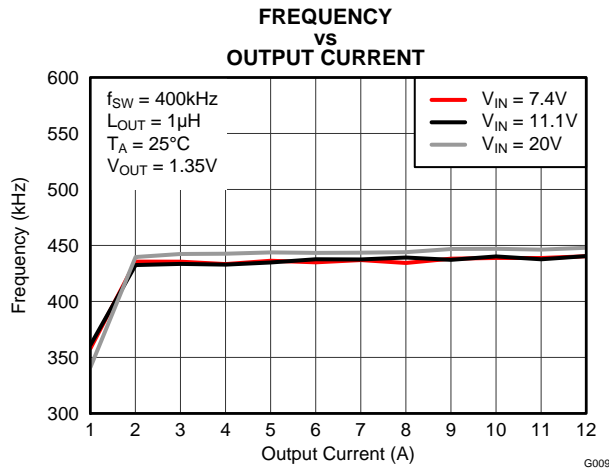

Figure 9.

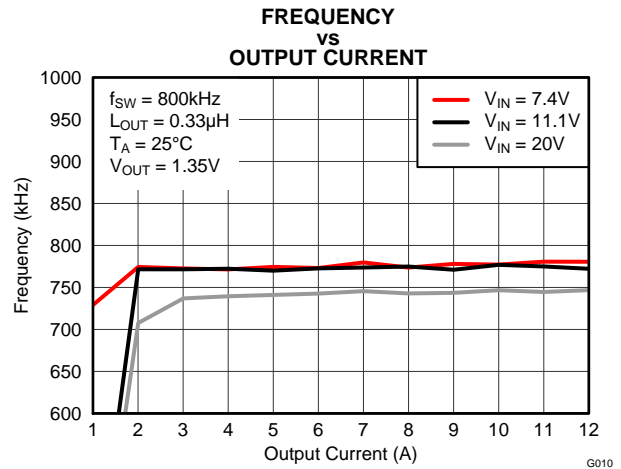

Figure 10.

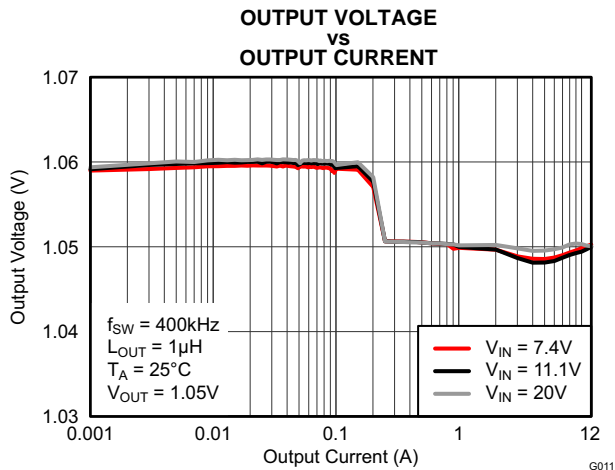

Figure 11.

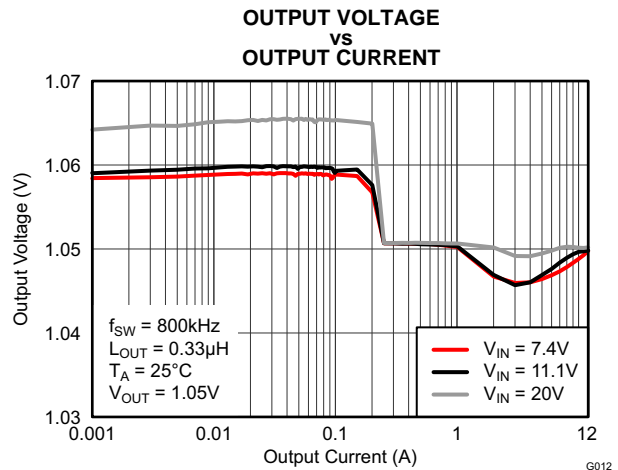

Figure 12.

TYPICAL CHARACTERISTICS (continued)

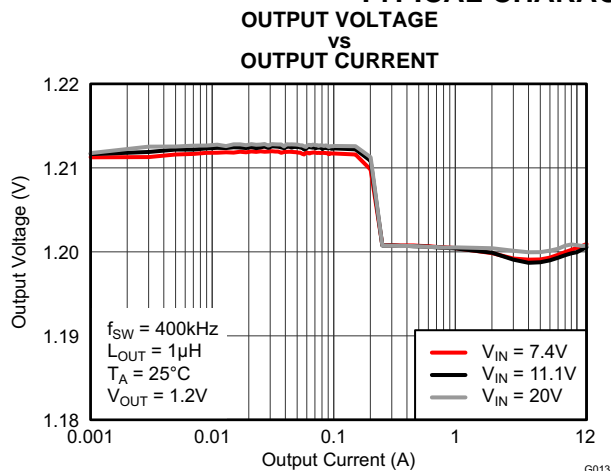

Figure 13.

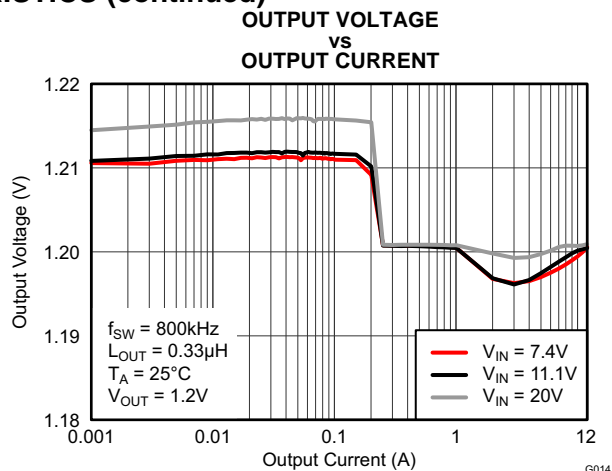

Figure 14.

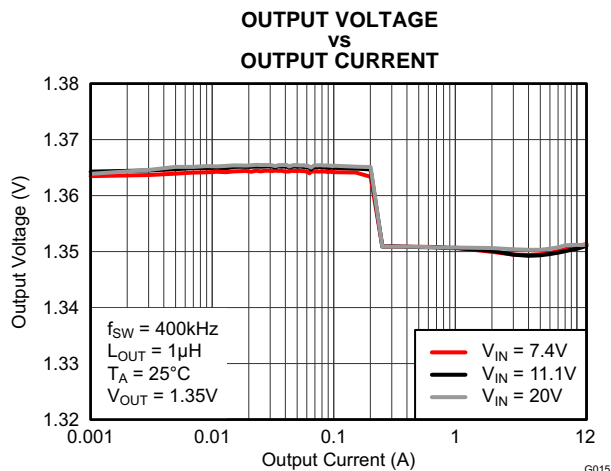

Figure 15.

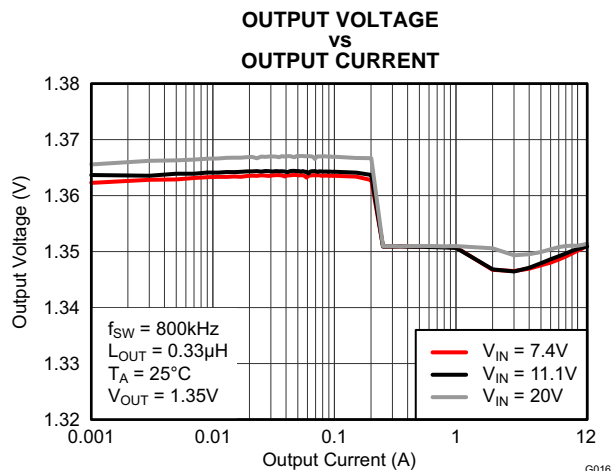

Figure 16.

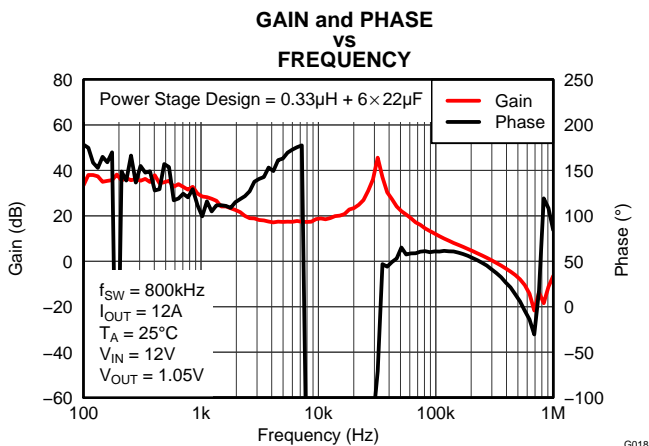

Figure 17.

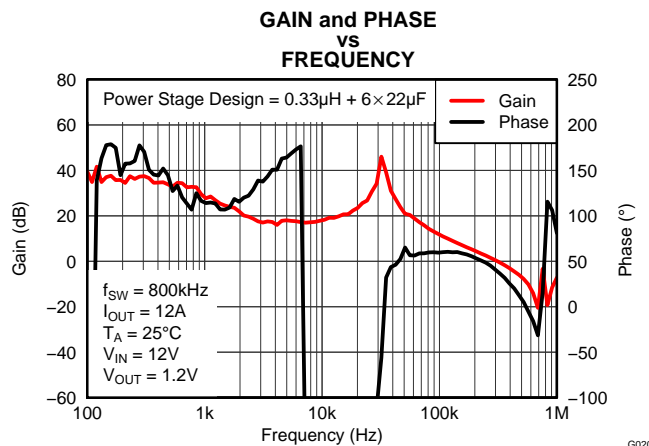

Figure 18.

TYPICAL CHARACTERISTICS (continued)

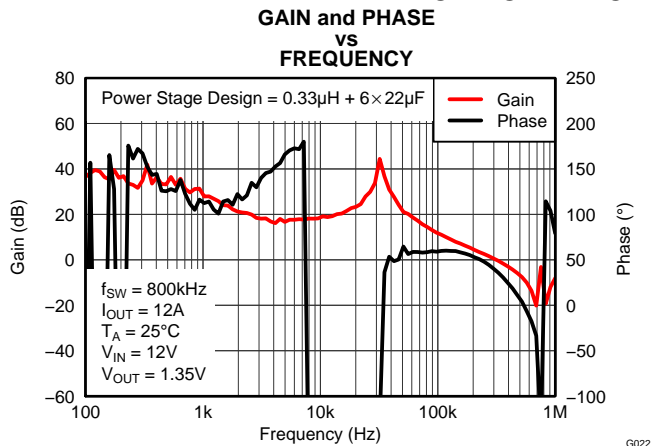

Figure 19.

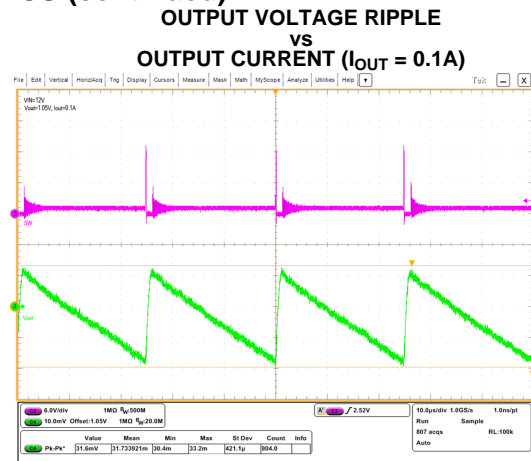

Figure 20.

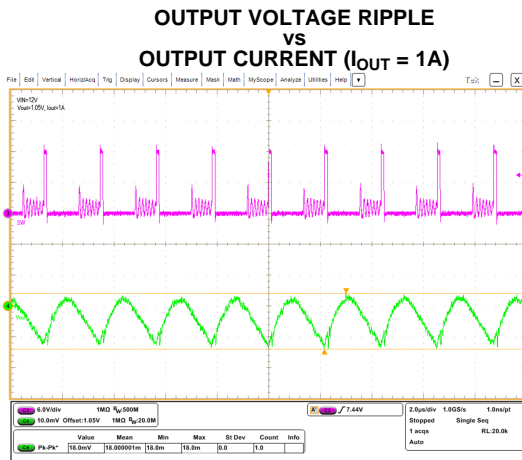

Figure 21.

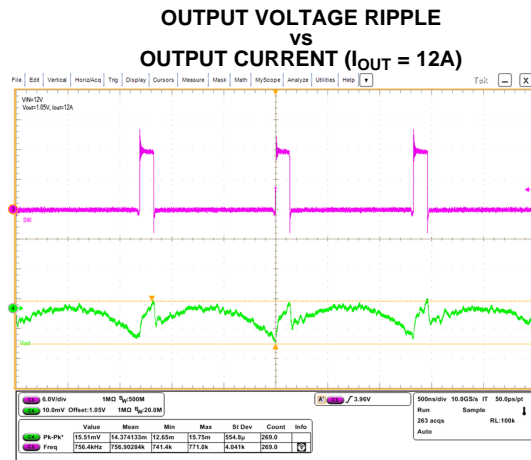

Figure 22.

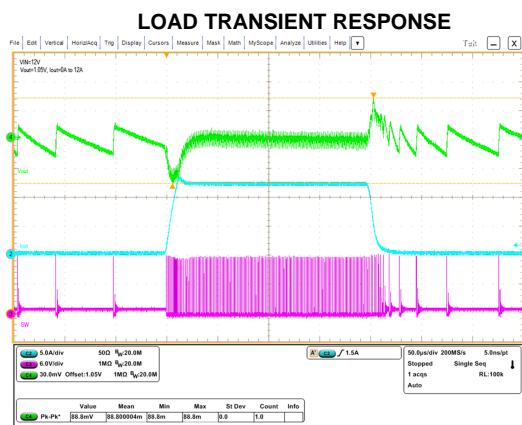

Figure 23.

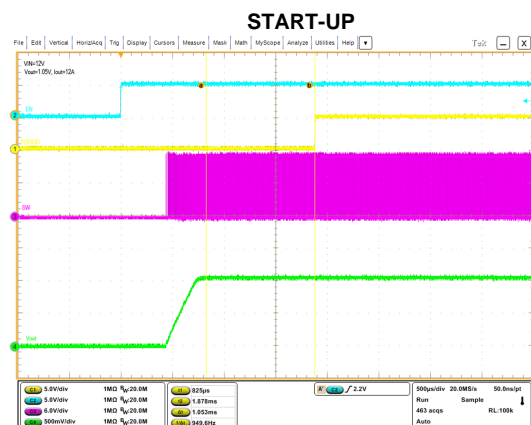

Figure 24.

TYPICAL CHARACTERISTICS (continued)

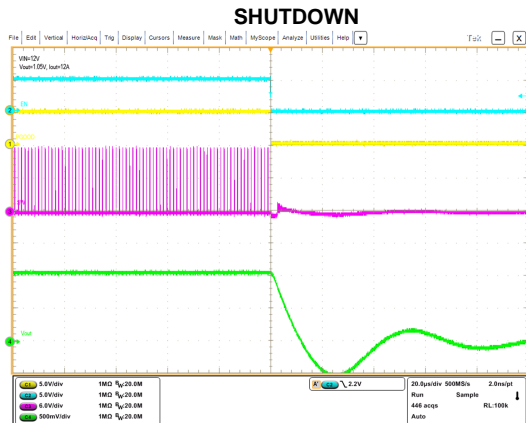

Figure 25.

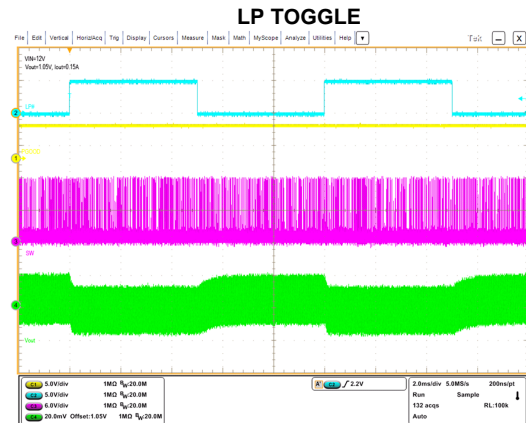

Figure 26.

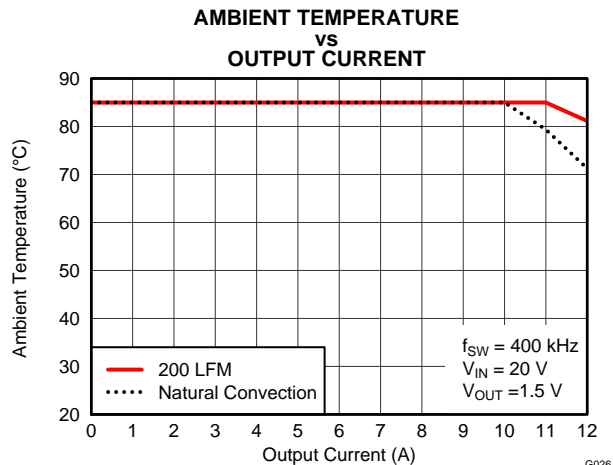

Figure 27.

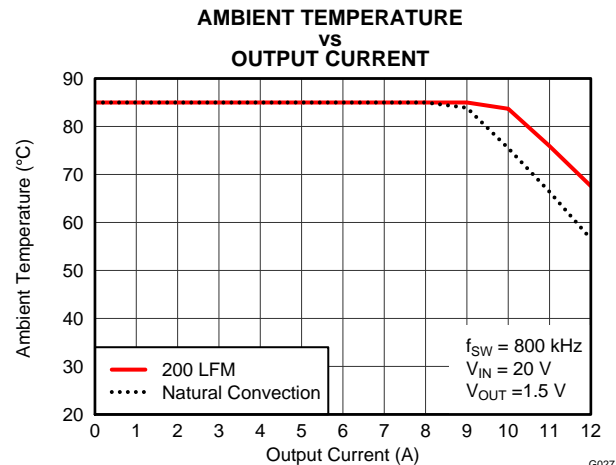

Figure 28.

APPLICATION INFORMATION

Functional Overview

The TPS51367 is a 12-A, integrated FET synchronous step-down converter with differential voltage feedback support.

It uses adaptive on-time D-CAP2 for compensation-less stable loop operation in POSCAP, POSCAP/MLCCs and all MLCCs output capacitor configurations.

TPS51367 automatically operates in discontinuous mode to optimize light-load efficiency. A 400-kHz and an 800-kHz switching frequency enables optimization of the power train for cost, size and efficiency performance of the design. The key feature of the TPS51367 is its ULQ™ mode to enable low-bias current (100 μ A in low power mode, enabled by LP#). This feature is extremely beneficial for long battery life in system standby mode.

VREF, REFIN, REFIN2 and Output Voltage

This device provides a 2.0-V, accurate voltage reference from the VREF pin. This output has a 300- μ A sourcing current capability to drive voltage setpoint reference through a voltage divider circuit as shown in [Figure 29](#). To ensure higher overall system voltage accuracy, the sum of the total resistance from VREF to GND should be designed to be more than 67 k Ω . A MLCC capacitor with a value of 0.1 μ F or larger should be attached close to the VREF pin. The voltage setpoint range supported by this device is between 0.6 V and 2.0 V.

This device also supports resistor-less fixed voltage operation by the use of both REFIN and REFIN2 pins. [Table 1](#) lists all the possible fixed voltage configurations by the REFIN and REFIN2 pin. The TPS51367 detects the state of both REFIN and REFIN2 during the initial startup and decides the output voltage setpoint for the operation.

Table 1. REFIN and REFIN2 Pin Settings

VOLTAGE (V)		V _{OUT} OUTPUT VOLTAGE (V)
REFIN PIN (V _{REFIN})	REFIN2 PIN (V _{REFIN2})	
GND	GND	1.05
FLOAT	GND	1.2
GND	FLOAT	1.5
FLOAT	FLOAT	1.35
Resistor dividers	Either GND or FLOAT	Adjustable from 0.6 to 2.0

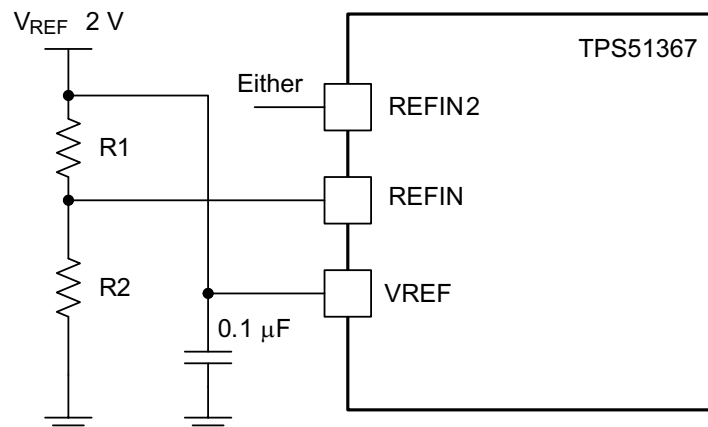

Figure 29. Setting the Output Voltage

PWM Operation

TPS51367 employs DCAP2 mode operation. It uses an internal phase compensation network (R_{C1} , R_{C2} , C_{C1} , C_{C2} and gain) to work with very low ESR output capacitors such as multi-layer ceramic capacitor (MLCC). The role of such network is to sense and scale the current ripple component of the output inductor current information and then use it in conjunction with the voltage feedback signal to achieve loop stability of the converter.

The transconductance (g_M) amplifier and SLEW capacitor ($C1$) forms an integrator. The output ripple voltage generated is inversed and averaged by this integrator. The AC information is superimposed onto otherwise DC information and forms a reference voltage at the input of the PWM comparator. As long as the integrator time constant is much larger than the inverse of the loop crossover frequency, the AC component is negligible.

$$\frac{g_M}{(2\pi \times C1)} \leq \frac{f_0}{10}$$

where

- g_M is 60 μS
 - f_0 is 1/3 or 1/4 of the switching frequency (f_{SW})
- (1)

The voltage difference ($V_{SLEW} - V_{SNS}$) is then compared to the $G \times (CSP - CSN)$ (see [Figure 31](#)) voltage at the PWM comparator inputs. The PWM comparator creates a SET signal to turn on the high-side MOSFET during each cycle when the current level falls below the loop demand (see [Figure 30](#)).

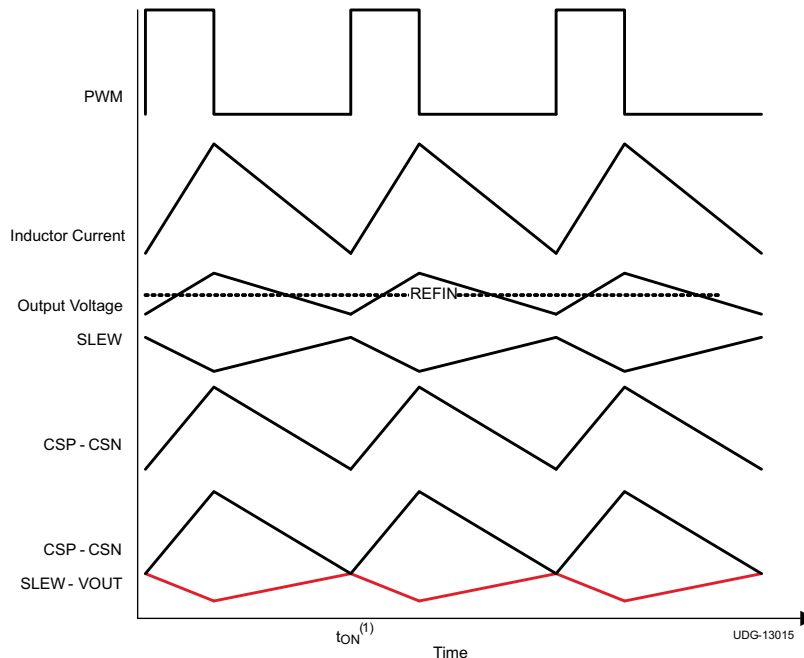

Figure 30. On-Time Waveforms ⁽¹⁾

(1) ON time is initiated by (VOUT-SLEW) and (CSP-CSN) crossover

The device operates at one distinct switching frequencies, 800 kHz. The switching frequency is configured by MODE pin for this converter operation (see Table 2). For stable operation of the buck converter, it is generally recommended to have a unity gain crossover (f_0) of 1/4 or 1/3 or the switching frequency. (see Table 2).

Table 2. Mode and Recommended Frequency Settings

MODE	FREQUENCY (kHz)		
	CROSSOVER (f_0)		SWITCHING (f_{sw})
	MIN	MAX	
GND	100	133	400
FLOAT	200	267	800

Given the range of the recommended unity gain frequency, the power stage design is flexible, as long as the following equation is satisfied.

$$f_{LC} = \frac{1}{2\pi \times \sqrt{L_{OUT} \times C_{OUT}}} \leq \frac{1}{10} \times f_0 \tag{2}$$

Operating in D-CAP2 mode, the overall loop response is dominated by the internal phase compensation network. The compensation network is designed to have two identical zeros at 8 kHz (800-kHz operation) in the frequency domain, which serves the purpose of splitting the LC double pole into one low frequency pole (same as the L-C double pole) and one high-frequency pole (greater than the unity gain crossover frequency).

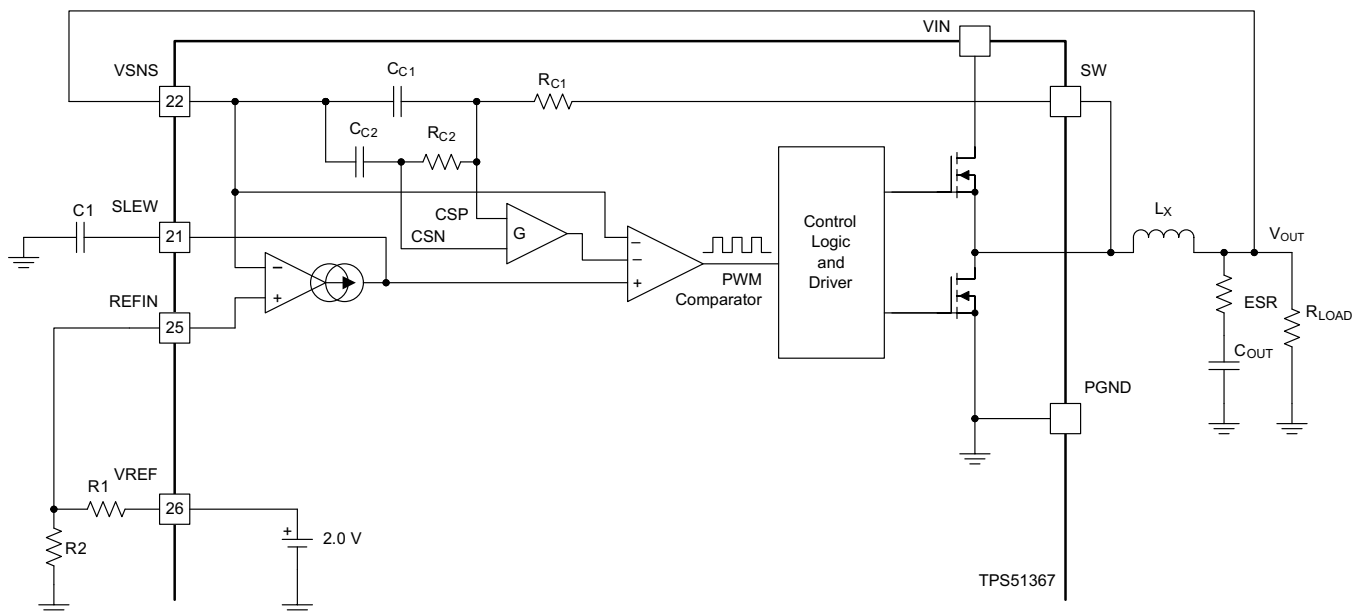

Figure 31. Simplified Architecture Illustrating DCAP2 Mode

Light-Load Operation

The mandatory light load operation for TPS51367 is referred to as auto skip. In auto-skip mode, the control logic automatically reduces its switching frequency to improve light load efficiency. To achieve this intelligence, a zero crossing detection comparator is used to prevent negative inductor current by turning off the low side FET when the SW crossing zero is detected. The equation below shows the boundary load condition of this skip mode and continuous conduction operation.

$$I_{LOAD(LL)} = \frac{(V_{IN} - V_{OUT})}{2 \times L_X} \times \frac{V_{OUT}}{V_{IN}} \times \frac{1}{f_{SW}} \tag{3}$$

Power Sequences: Soft-Start and Power Good

Prior to asserting EN high, the power stage conversion voltage and V5IN voltage should be up and running. When EN is asserted high, TPS51367 provides soft start operation to suppress in-rush current during startup. The soft start action is achieved by an internal SLEW current of 10 μ A (typ) sourcing into a small external MLCC capacitor connected from SLEW pin to GND.

Use [Equation 4](#) to determine the soft-start timing.

$$t_{SS} = C_{SLEW} \times \frac{V_{OUT}}{I_{SLEW}}$$

where

- C_{SLEW} is the soft-start capacitance
 - V_{OUT} is the output voltage
 - I_{SLEW} is the internal, 10- μ A current source
- (4)

The TPS51367 includes a PGOOD open drain output. During the startup, once the output voltage is slewing up within –8% of the final setpoint target, the PGOOD becomes asserted after 1.5 ms of delay from the end of the soft-start period. During the operation, if the output voltage rises beyond 120% (typ) of the setpoint, the PGOOD pin becomes immediately de-asserted without hysteresis. Re-asserting the PGOOD pin requires either resetting either the V5IN pin or the EN pin. If the output voltage falls below 68% (typ) of the setpoint, the PGOOD pin becomes immediately de-asserted without hysteresis. Re-asserting the PGOOD pin requires resetting either the V5IN pin or the EN pin.

Fault Protection

Overcurrent Limit

TPS51367 integrates both high side and low side FETs to support a maximum DC current of 12-A operation. The current sensing method employed for over current limit is to monitor the SW node during the “ON” state of the low side FET for each switching cycle. TRIP pin is used to program one of the two current limits for TPS51367 operation (see [Table 3](#)). When the overcurrent limit is detected, the converter does not allow the next “ON” cycle for the high side FET until the overcurrent limit is no longer reached. This ensures the safe operation of the converter. And when the overcurrent limit condition persists, the current to the load exceeds the current to the output capacitors, the output voltage tends to fall. When the output voltage falls below the undervoltage protection threshold, the converter latch shut down.

Table 3. TRIP Pin Settings

TRIP	TYPICAL OCL LIMIT I_{OCL} (A)
GND	8
5V	12
FLOAT	16

Negative Overcurrent Limit

TPS51367 is also protected by the negative over current limit. Both positive and negative current limit is programmed by the TRIP pin. Negative current limit level is the same as that of positive current limit level (see [Table 3](#)). During the normal converter operation, negative current is not allowed due to the mandatory light load operation for this device (Auto Skip). It is during the OOB or OVP operation, negative overcurrent might be engaged.

Out-of-Bounds Operation (OOB)

When the output voltage rises to 8% above the target value, the out-of-bound operation starts. During the OOB operation, the controller operates in forced PWM-only mode by turning on low side FET. Turning on the low side FET beyond the zero inductor current can quickly discharge the output capacitor thus causing V_{OUT} to fall quickly towards setpoint. During the operation, the cycle by cycle negative current limit is also activated to ensure the safe operation of the internal FETs.

Overvoltage Protection (OVP) and Undervoltage Protection (UVP)

When the output voltage rises to a level 20% (typ) higher than the setpoint voltage, an overvoltage condition is present. When a 0-V event is detected, the converter turns off the high side FET and turns on the low side FET. The operation continues until the cycle by cycle negative current limit is reached and low side FET is turned off and high side FET is turned on, for a minimum on-time. After the minimum on-time expires, the high side FET is driven off and low side FET is driven on again until negative current limit is reached or V_{OUT} is discharged to 0 V. When the V_{OUT} is discharged to 0 V, both high-side and low-side FETs are latched off. An OVP fault requires the V5IN voltage to fall below POR threshold or EN reset to clear.

Undervoltage Protection (UVP)

The undervoltage protection (UVP) is set when the V_{OUT} voltage falls below 68% (typ) of the setpoint voltage for 1msec or longer. In this fault condition, the converter turns off both high-side and low-side FETs. The UVP function is enabled after 1.4 ms of soft start completion. An UVP fault requires 5-V UVLO or EN reset.

V5IN Undervoltage Lockout (UVLO) Protection

TPS51367 has a 5-V supply undervoltage lockout protection (UVLO) threshold. When the V5IN voltage is lower than UVLO threshold voltage, V_{out} is shut off. This is a non-latch protection.

Power-On-Reset (POR)

To prevent single rail supply voltage brown-out due to output OV condition, when the output voltage is shut down due to OVP fault, Power-on-Reset (POR) on V5IN is implemented. To reset OVP fault, V5IN voltage must fall below POR threshold voltage of 1.7 V (typ) or EN reset to clear.

Thermal Shutdown

TPS51367 includes an internal temperature monitor. If the die temperature exceeds the threshold (published in the EC table of this datasheet), the converter will be shutdown. This is a non-latch protection and the operation is restarted with soft-start sequence when the device temperature is reduced by the hysteresis.

DESIGN PROCEDURE

Introduction

The simplified design procedure is done for a VCCIO rail for Intel platform application using TPS51367.

Step One: Determine the system specifications.

The VCCIO rail requirements provide the following key parameters:

- $V_{OUT} = 1.05\text{ V}$
- $I_{CC(max)} = 6\text{ A}$
- $I_{DYN(max)} = 4\text{ A}$

Step Two: Determine the power supply design specifications.

The input voltage range and operating frequency are of primary interest. For this example:

- $7.4\text{ V} \leq V_{IN} \leq 19.5\text{ V}$
- $f_{SW} = 800\text{ kHz}$

Step Three: Set the output voltage.

TPS51367 supports resistor-less fixed voltage operation by the use of both REFIN and REFIN2 pins (see [Table 1](#)). Grounding both REFIN and REFIN2 pins provides a 1.05-V fixed output setpoint.

Step Four: Determine inductance value and choose inductor.

Smaller values of inductor have better transient performance and smaller physical size but higher ripple and lower efficiency. Higher values have the opposite characteristics. It is common practice to limit the ripple current to 25% to 50% of the maximum current. For this example, use 30% as a starting point. $I_{L(P-P)} = 6\text{ A} \times 0.30 = 1.8\text{ A}$. For a switching frequency of 800 kHz, maximum 19.5-V input and 1.05-V output.

$$L = \frac{V \times dT}{I_{P-P}} = \frac{(V_{IN} - V_{OUT}) \times \left(\frac{V_{OUT}}{f_{SW} \times V_{IN}} \right)}{I_{P-P}} = \frac{(19.5\text{ V} - 1.05\text{ V}) \times \left(\frac{1.05\text{ V}}{800\text{ kHz} \times 19.5\text{ V}} \right)}{1.8\text{ A}} = 0.68\text{ }\mu\text{H} \quad (5)$$

For this application, a 0.68- μH , 6.8 mm \times 7.3 mm \times 3.0 mm inductor with typical DCR of 4.8 m Ω and heating current of 16 A is chosen. The Cyntec part number of the inductor is PIMB063T.

Step Five: Calculate SLEW capacitance.

The SLEW pin is used to program the soft-start time. During soft-start operation, the current source used to program the SLEW rate is 10 μA (typ). In this design example, the soft-start timing should be target to be in the range of 500 μs to 2 ms. The proper slew rate design minimizes large inductor current perturbation during the startup, thus reducing the possibility of acoustic noise in the system.

$$C_{SLEW} = I_{SLEW} \times \frac{dt}{\Delta V_{OUT}} = 10\text{ nF} \quad (6)$$

- $I_{SLEW} = 10\text{ }\mu\text{A}$,
- $dt = t_{SS} = 1\text{ ms}$
- $\Delta V_{OUT} = 1.05\text{ V}$

Step Six: Select the proper OCL.

There are two options for the over current limit (see [Table 3](#)). For this application example, because $I_{CC(max)} = 6\text{ A}$, the proper OCL level should be set at least 30% over the $I_{CC(max)}$ level, which makes the 8-A OCL appropriate for this design. Grounding the TRIP pin achieves this effect.

Step Seven: Determine the output capacitance.

The amount of the output capacitance needed for this design is both a function of loop stability and of transient requirement.

Stability Considerations

The switching frequency of the design example is 800 kHz (which is set by the MODE pin, see [Table 3](#)). For D-CAP2 mode operation, it is generally recommended to have a unity gain crossover (f_0) of less than 1/4 or 1/3 of the switching frequency, which is approximately between 200 kHz and 266 kHz. In this design example, use 1/4.

$$f_0 = \frac{f_{SW}}{4} = 200\text{kHz} \quad (7)$$

Given the range of the recommended unity gain crossover frequency, the power stage design is flexible, as long as the L-C double pole frequency is less than 10% of f_0 .

When the above criteria is met, the internal compensation network provides sufficient phase boost at the unity gain crossover frequency such that the converter is stable with sufficient phase margin (greater than 60 deg.).

When the ESR frequency of the output bulk capacitor is in the vicinity of the unity gain crossover frequency of the loop, additional phase boost can be achieved. This applies to higher ESR output bulk capacitor, POSCAP and SPCAP.

When the ESR frequency of the output capacitor is beyond the unity gain crossover frequency of the control loop, no additional phase boost is achieved. This applies to low or ultra low ESR output capacitor, such as MLCCs.

For this application example, consider only all MLCCs for output capacitors. Based on [Equation 3](#) and [Equation 7](#), the minimum capacitance for stable operation is calculated to be 110 μF .

Transient considerations

- $I_{DYN(max)} = 4 \text{ A}$
- $di/dt = 2.5 \text{ A}/\mu\text{s}$
- V_{OUT} deviation = $\pm 3\%$ for the given transient

Use [Equation 8](#) and [Equation 9](#) to estimate the amount of capacitance needed for a given dynamic load/release.

$$C_{OUT(min_under)} = \frac{L \times (\Delta I_{LOAD(max)})^2 \times \left(\frac{V_{OUT} \times t_{SW}}{V_{IN(min)}} + t_{MIN(off)} \right)}{2 \times \Delta V_{LOAD(insert)} \times \left(\left(\frac{V_{IN(min)} - V_{OUT}}{V_{IN(min)}} \right) \times t_{SW} - t_{MIN(off)} \right) \times V_{OUT}} \quad (8)$$

$$C_{OUT(min_over)} = \frac{L_{OUT} \times (\Delta I_{LOAD(max)})^2}{2 \times \Delta V_{LOAD(release)} \times V_{OUT}} \quad (9)$$

Based on these calculation, to meet the transient requirement, the minimum amount of capacitance in this design is 164 μF .

Considering both stability and transient, the minimum capacitance is 164 μF . The design example uses 8, 22- μF capacitors with minor consideration of the MLCC derating for both DC and AC effect.

Step Eight: Select decoupling and peripheral components.

For the TPS51367, peripheral capacitors use the following minimum values of ceramic capacitance. X5R or better temperature coefficient is recommended. Tighter tolerance and higher voltage rating are always appropriate.

- V_{5IN} decoupling $\geq 2.2 \mu\text{F}$, $\geq 10 \text{ V}$
- V_{REF} decoupling $0.1 \mu\text{F}$ to $1 \mu\text{F}$, $\geq 4 \text{ V}$
- Bootstrap capacitor $\geq 0.1 \mu\text{F}$, $\geq 10 \text{ V}$
- Pull-up resistors on PGOOD, 100 k Ω

Step Nine: Layout guidelines.

[Figure 32](#) applies to the layer where device is situated. Additional reinforcement of VIN, PGND, and VOUT through vias are always recommended.

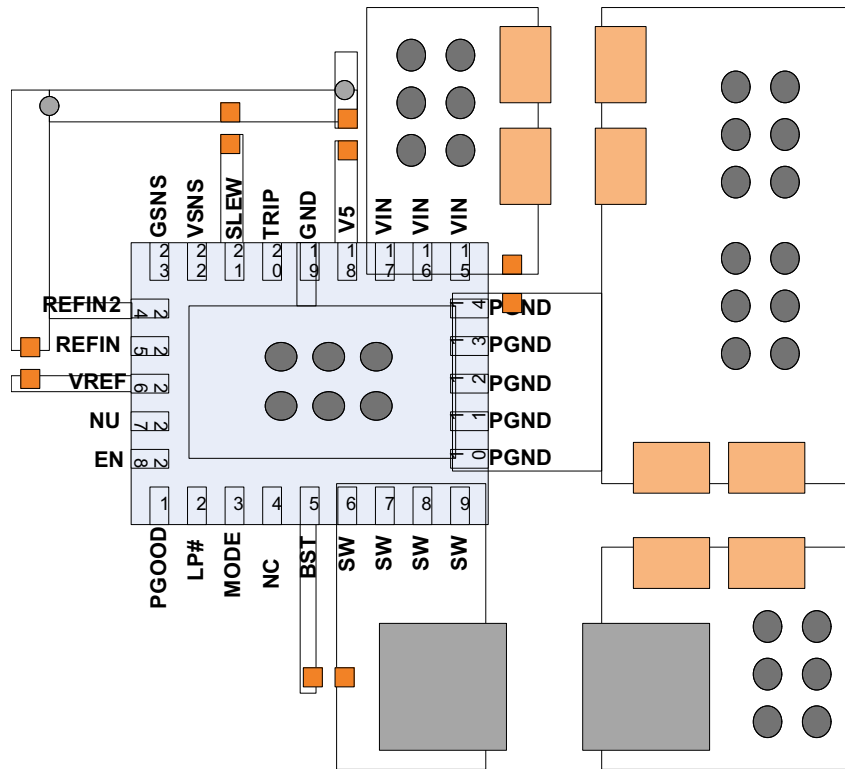

Figure 32. TPS51367 Design Layout

Input capacitors, output capacitors, and the output inductor are the power components and should be placed on one side of the PCB. Small signal components can be placed on the same side of the PCB with proper ground isolation or the opposite side with at least one inner ground plane in between, depending on the system/motherboard design requirement.

All sensitive analog traces and components such as VSNS, GSNS, SLEW, VREF, REFIN and REFIN2 should be placed away from the high voltage switching node, such as SW and BST to avoid switching noise coupling. Use internal layer(s) as ground plane(s) and shield feedback traces from power traces.

VSNS can be connected directly to the output voltage sense point at the load device or the bulk capacitor at the converter side. Connect GSNS to ground return at the general ground plane/layer. VSNS and GSNS can be used for the purpose of remote sensing across the load device, however, ensure to minimize the routing trace length to prevent excess noise injection into the sense lines.

In order to effectively remove heat from the package, prepare the thermal land and solder to the package thermal pad. Wide trace of the component-side copper, connected to this thermal land, helps to dissipate the heat. Numerous vias (at least 6) with a 0.3-mm diameter connected from the thermal land to the internal/solder side ground plane(s) should be used to help dissipation.

REFERENCE DESIGNS

This section describes three typical application circuits using the TPS51367.

Design 1

This design is a VCCIO application with an output voltage of 1.05 V, maximum processor current ($I_{CC(max)}$) of 6 A, an OCL of 8 A and a switching frequency of 800 kHz.

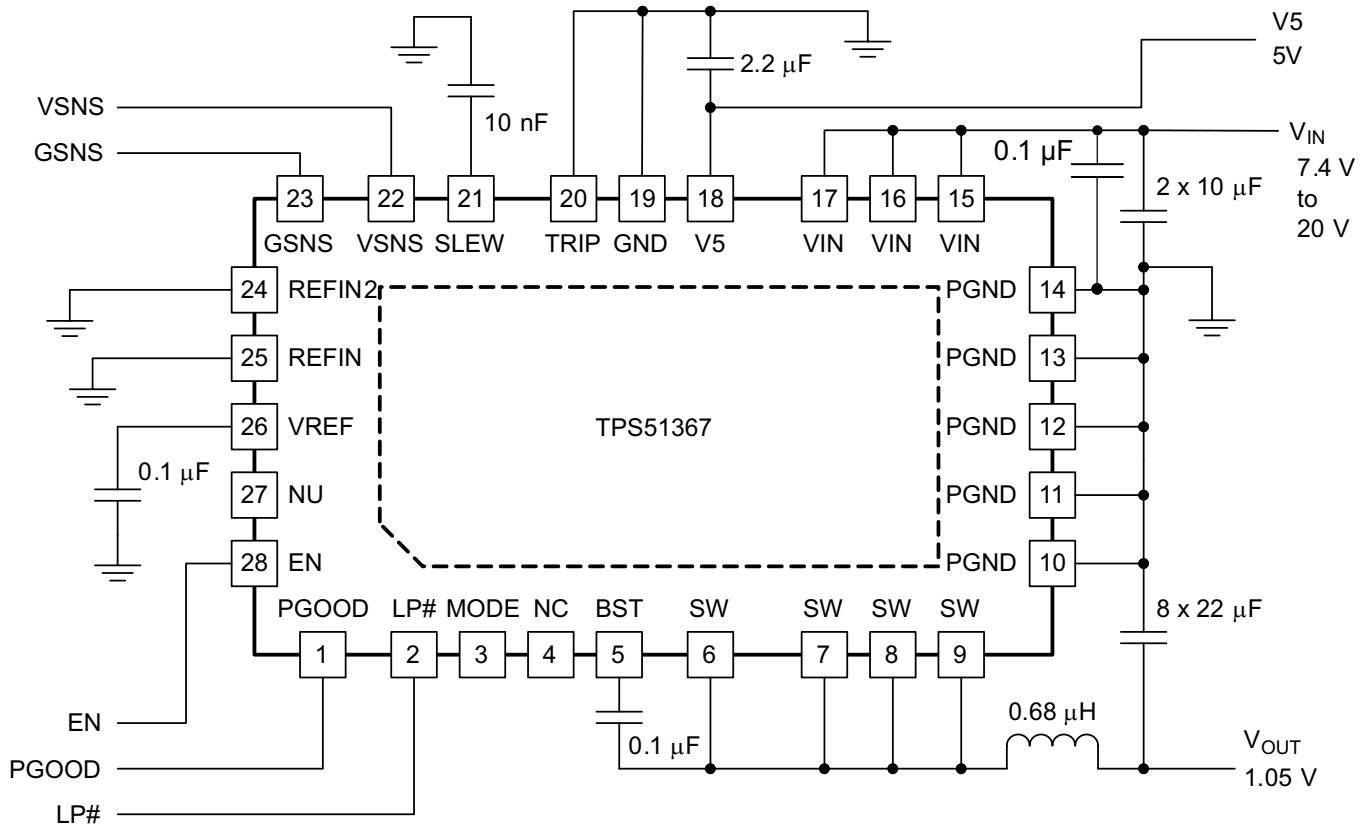

Figure 33. Design 1: Application Schematic

Table 4. Design 1: List of Materials

REFERENCE DESIGNATOR	QTY	SPECIFICATION	MANUFACTURER	PART NUMBER
C _{IN}	2	10 μF, 25 V	Taiyo Yuden	TMK325BJ106MM
C _{OUT}	8	22 μF, 6.3 V	Murata	GRM21BB30J226ME38
L _{OUT}	1	0.68 μH, 4.8 mΩ	Cyntec	PIMB063T-R68MS-63

Design 2:

This design is a DDR3L, VDDQ, application with an output voltage of 1.35 V, maximum processor current ($I_{CC(max)}$) of 8 A, an OCL of 12 A, and a switching frequency of 400 kHz.

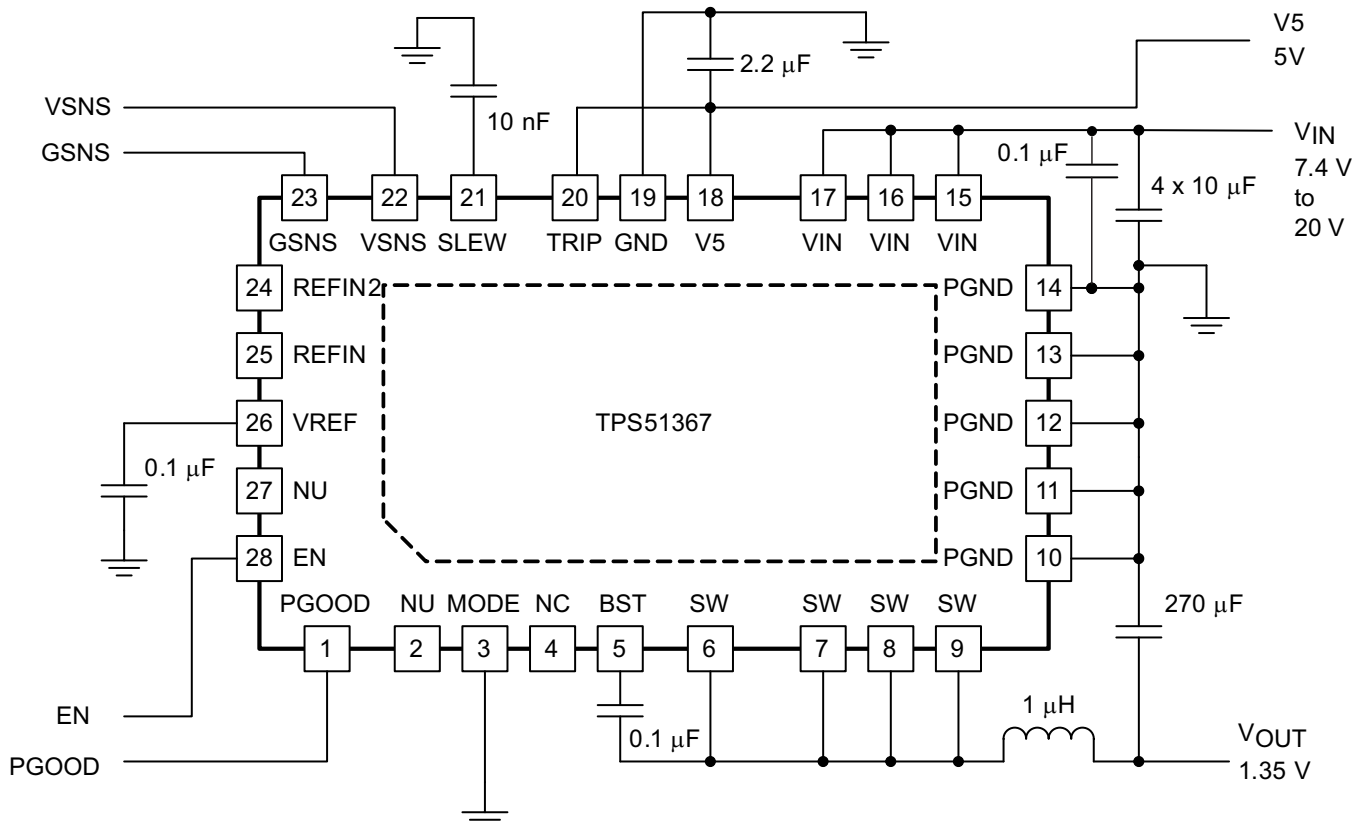

Figure 34. Design 2: Application Schematic

Table 5. Design 2: List of Materials

REFERENCE DESIGNATOR	QTY	SPECIFICATION	MANUFACTURER	PART NUMBER
C _{IN}	4	10 μF, 25 V	Taiyo Yuden	TMK325BJ106MM
C _{OUT}	1	270 μF, 2 V	Panasonic	2TPSF270M6E
L _{OUT}	1	1 μH, 6.7 mΩ	Cyntec	PCME063T-1R0MS-63

Design 3:

This design is a DDR3, VDDQ, application with an output voltage of 1.5 V, maximum processor current ($I_{CC(max)}$) of 12 A, an OCL of 16 A, and a switching frequency of 400 kHz.

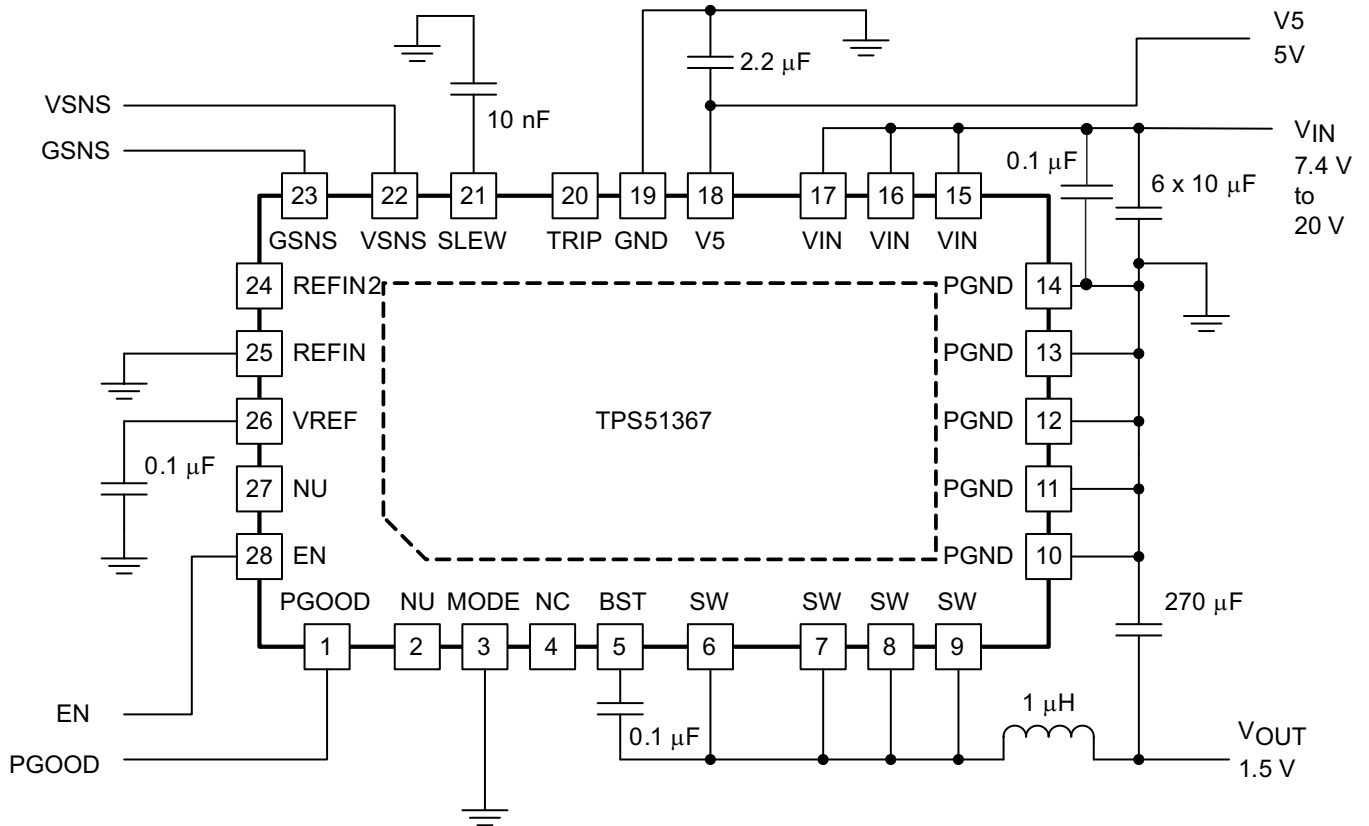

Figure 35. Design 3: Application Schematic

Table 6. Design 3: List of Materials

REFERENCE DESIGNATOR	QTY	SPECIFICATION	MANUFACTURER	PART NUMBER
C _{IN}	6	10 μF, 25 V	Taiyo Yuden	TMK325BJ106MM
C _{OUT}	1	270 μF, 2 V	Panasonic	2TPSF270M6E
L _{OUT}	1	1 μH, 6.7 mΩ	Cyntec	PCME063T-1R0MS-63

REVISION HISTORY

NOTE: Page numbers of current version may differ from previous versions.

Changes from Original (February 2013) to Revision A	Page
• Added MIN and MAX values to I_{OCL} spec in Elec Char table	5
• Changed the Functional Block Diagram V_{REFIN} signal line identifier on the UV-detect device from " $V_{REFIN} - 32\%$ " to " $V_{REFIN} - 34\%$ ". Changed signal line identifier on the high-side comparator from " $V_{REFIN} + 8/20\%$ " to " $V_{REFIN} + 20\%$ ". Changed the high-side device symbol from hysteresis to a comparator. Changed signal line identifier on the low-side device from " $V_{REFIN} - 8/32\%$ " to " $V_{REFIN} - 8/34\%$ ".	8
• Changed Figure 22 graph X-axis label from "OUTPUT CURRENT ($I_{OUT} = 10A$)" to "OUTPUT CURRENT ($I_{OUT} = 12A$)" in Typical Characteristics section.	12
• Added Land pads for a 0.1- μ F capacitor between VIN and PGND of the TPS51367 Design Layout figure.	21
• Added a 0.1- μ F capacitor symbol between VIN and PGND of the Design 1: Application Schematic.	22
• Changed L_{OUT} inductor part number from PIMB063T to PIMB063T-R68MS-63 in Design 1: List of Materials table.	22
• Changed text from "LPDDR3" to "DDR3L" in Design 2 description section.	23
• Added 0.1 μ F capacitor symbol between VIN and PGND in Design 2: Application Schematic figure	23
• Changed L_{OUT} inductor spec from 1 μ H, 6.5 m Ω to 6.7 m Ω , and part number from PCME063T to PIMB063T-1R0MS-63 in Design 2: List of Materials table.	23
• Changed QTY of C_{IN} from 4 to 6; changed L_{OUT} inductor spec from 1 μ H, 6.5 m Ω to 6.7 m Ω , and part number from PCME063T to PIMB063T-1R0MS-63 in Design 3: List of Materials table.	24

PACKAGING INFORMATION

Orderable Device	Status (1)	Package Type	Package Drawing	Pins	Package Qty	Eco Plan (2)	Lead/Ball Finish	MSL Peak Temp (3)	Op Temp (°C)	Top-Side Markings (4)	Samples
TPS51367RVER	ACTIVE	VQFN	RVE	28	3000	Pb-Free (RoHS Exempt)	CU NIPDAU	Level-2-260C-1 YEAR	-10 to 85	TPS51367	Samples
TPS51367RVET	ACTIVE	VQFN	RVE	28	250	Pb-Free (RoHS Exempt)	CU NIPDAU	Level-2-260C-1 YEAR	-10 to 85	TPS51367	Samples

(1) The marketing status values are defined as follows:

ACTIVE: Product device recommended for new designs.

LIFEBUY: TI has announced that the device will be discontinued, and a lifetime-buy period is in effect.

NRND: Not recommended for new designs. Device is in production to support existing customers, but TI does not recommend using this part in a new design.

PREVIEW: Device has been announced but is not in production. Samples may or may not be available.

OBSOLETE: TI has discontinued the production of the device.

(2) Eco Plan - The planned eco-friendly classification: Pb-Free (RoHS), Pb-Free (RoHS Exempt), or Green (RoHS & no Sb/Br) - please check <http://www.ti.com/productcontent> for the latest availability information and additional product content details.

TBD: The Pb-Free/Green conversion plan has not been defined.

Pb-Free (RoHS): TI's terms "Lead-Free" or "Pb-Free" mean semiconductor products that are compatible with the current RoHS requirements for all 6 substances, including the requirement that lead not exceed 0.1% by weight in homogeneous materials. Where designed to be soldered at high temperatures, TI Pb-Free products are suitable for use in specified lead-free processes.

Pb-Free (RoHS Exempt): This component has a RoHS exemption for either 1) lead-based flip-chip solder bumps used between the die and package, or 2) lead-based die adhesive used between the die and leadframe. The component is otherwise considered Pb-Free (RoHS compatible) as defined above.

Green (RoHS & no Sb/Br): TI defines "Green" to mean Pb-Free (RoHS compatible), and free of Bromine (Br) and Antimony (Sb) based flame retardants (Br or Sb do not exceed 0.1% by weight in homogeneous material)

(3) MSL, Peak Temp. -- The Moisture Sensitivity Level rating according to the JEDEC industry standard classifications, and peak solder temperature.

(4) Multiple Top-Side Markings will be inside parentheses. Only one Top-Side Marking contained in parentheses and separated by a "~" will appear on a device. If a line is indented then it is a continuation of the previous line and the two combined represent the entire Top-Side Marking for that device.

Important Information and Disclaimer: The information provided on this page represents TI's knowledge and belief as of the date that it is provided. TI bases its knowledge and belief on information provided by third parties, and makes no representation or warranty as to the accuracy of such information. Efforts are underway to better integrate information from third parties. TI has taken and continues to take reasonable steps to provide representative and accurate information but may not have conducted destructive testing or chemical analysis on incoming materials and chemicals. TI and TI suppliers consider certain information to be proprietary, and thus CAS numbers and other limited information may not be available for release.

In no event shall TI's liability arising out of such information exceed the total purchase price of the TI part(s) at issue in this document sold by TI to Customer on an annual basis.

TAPE AND REEL INFORMATION

QUADRANT ASSIGNMENTS FOR PIN 1 ORIENTATION IN TAPE

*All dimensions are nominal

Device	Package Type	Package Drawing	Pins	SPQ	Reel Diameter (mm)	Reel Width W1 (mm)	A0 (mm)	B0 (mm)	K0 (mm)	P1 (mm)	W (mm)	Pin1 Quadrant
TPS51367RVER	VQFN	RVE	28	3000	330.0	12.4	3.8	4.8	1.6	8.0	12.0	Q1
TPS51367RVET	VQFN	RVE	28	250	180.0	12.4	3.8	4.8	1.6	8.0	12.0	Q1

TAPE AND REEL BOX DIMENSIONS

*All dimensions are nominal

Device	Package Type	Package Drawing	Pins	SPQ	Length (mm)	Width (mm)	Height (mm)
TPS51367RVER	VQFN	RVE	28	3000	367.0	367.0	35.0
TPS51367RVET	VQFN	RVE	28	250	210.0	185.0	35.0

RVE (R-PVQFN-N28)

PLASTIC QUAD FLATPACK NO-LEAD

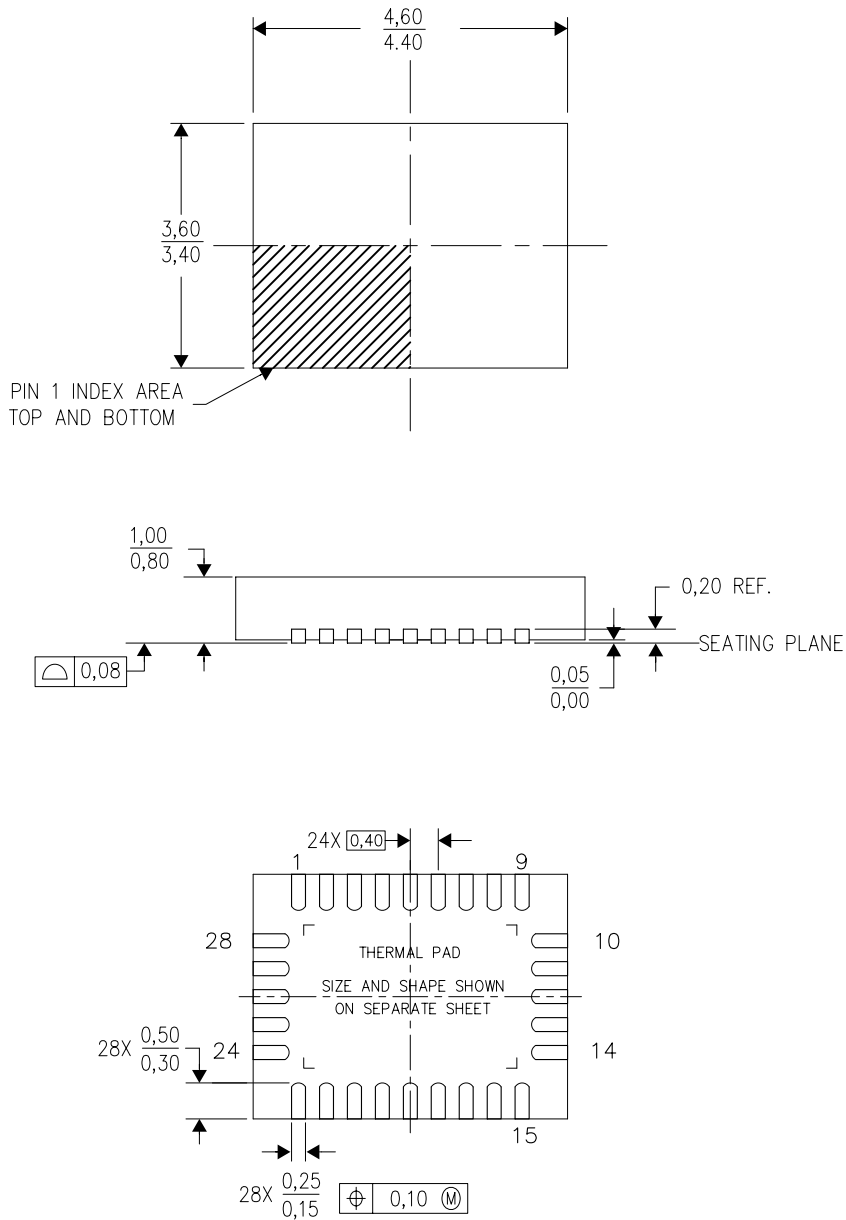

4211382/B 05/11

- NOTES:
- A. All linear dimensions are in millimeters. Dimensioning and tolerancing per ASME Y14.5-1994.
 - B. This drawing is subject to change without notice.
 - C. Quad Flatpack, No-leads (QFN) package configuration.
 - D. The package thermal pad must be soldered to the board for thermal and mechanical performance.
 - E. See the additional figure in the Product Data Sheet for details regarding the exposed thermal pad features and dimensions.
 - E. Falls within JEDEC MO-220.

THERMAL PAD MECHANICAL DATA

RVE (R-PVQFN-N28)

PLASTIC QUAD FLATPACK NO-LEAD

THERMAL INFORMATION

This package incorporates an exposed thermal pad that is designed to be attached directly to an external heatsink. The thermal pad must be soldered directly to the printed circuit board (PCB). After soldering, the PCB can be used as a heatsink. In addition, through the use of thermal vias, the thermal pad can be attached directly to the appropriate copper plane shown in the electrical schematic for the device, or alternatively, can be attached to a special heatsink structure designed into the PCB. This design optimizes the heat transfer from the integrated circuit (IC).

For information on the Quad Flatpack No-Lead (QFN) package and its advantages, refer to Application Report, QFN/SON PCB Attachment, Texas Instruments Literature No. SLUA271. This document is available at www.ti.com.

The exposed thermal pad dimensions for this package are shown in the following illustration.

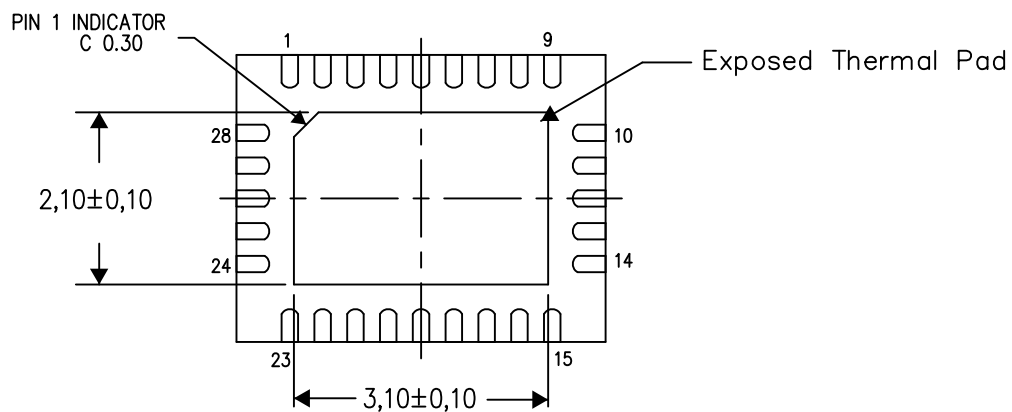

Bottom View

Exposed Thermal Pad Dimensions

4211776/D 09/12

NOTE: All linear dimensions are in millimeters

RVE (R-PWQFN-N28)

PLASTIC QUAD FLATPACK NO-LEAD

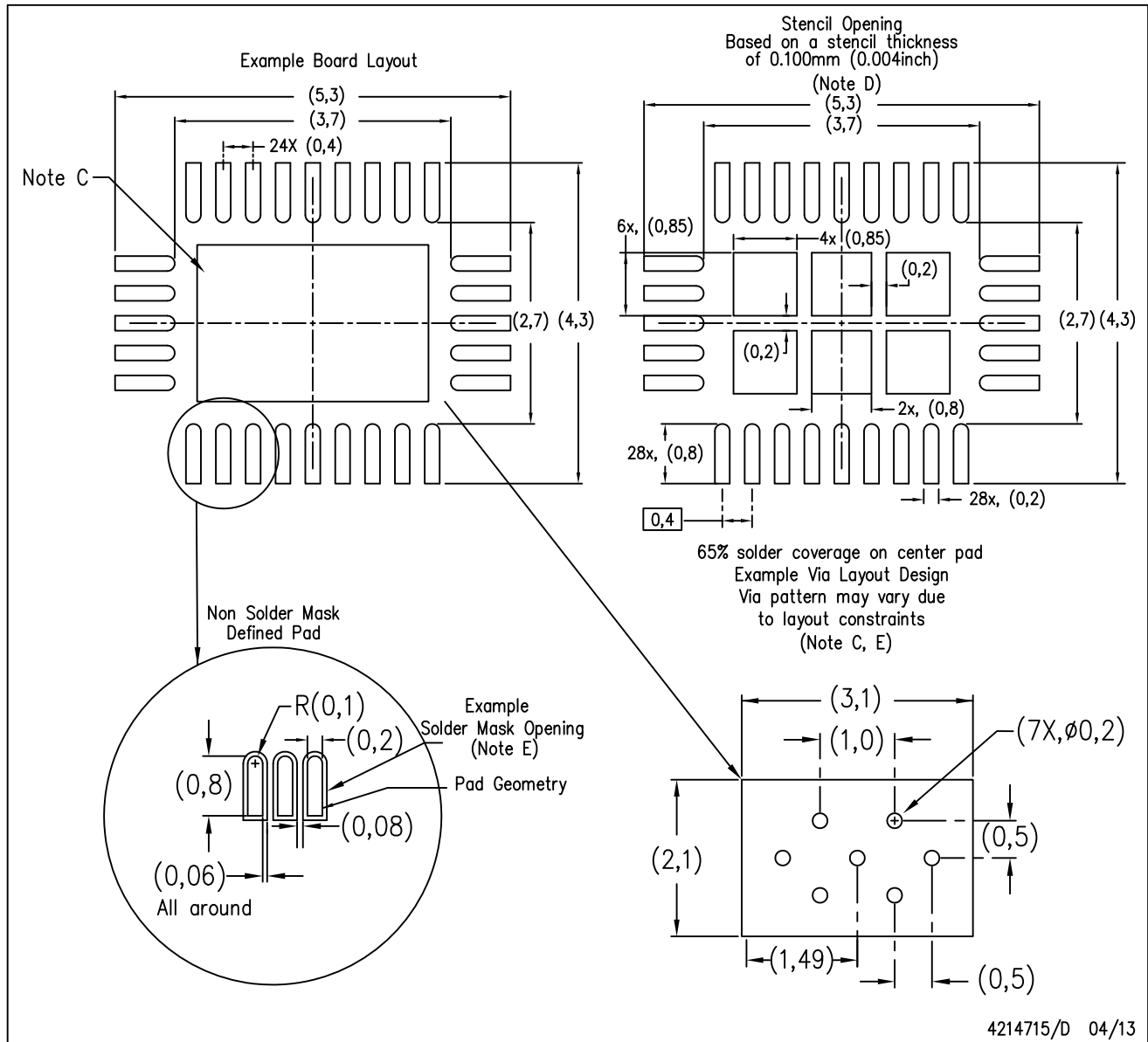

- NOTES:
- All linear dimensions are in millimeters.
 - This drawing is subject to change without notice.
 - This package is designed to be soldered to a thermal pad on the board. Refer to Application Note, Quad Flat-Pack Packages, Texas Instruments Literature No. SLUA271, and also the Product Data Sheets for specific thermal information, via requirements, and recommended board layout. These documents are available at www.ti.com <<http://www.ti.com>>.
 - Laser cutting apertures with trapezoidal walls and also rounding corners will offer better paste release. Electroformed stencils offer adequate release at thicker values/lower Area Ratios. Customers should contact their board assembly site for stencil design recommendations. Refer to IPC 7525 for stencil design considerations.
 - Customers should contact their board fabrication site for minimum solder mask web tolerances between signal pads.

IMPORTANT NOTICE

Texas Instruments Incorporated and its subsidiaries (TI) reserve the right to make corrections, enhancements, improvements and other changes to its semiconductor products and services per JESD46, latest issue, and to discontinue any product or service per JESD48, latest issue. Buyers should obtain the latest relevant information before placing orders and should verify that such information is current and complete. All semiconductor products (also referred to herein as "components") are sold subject to TI's terms and conditions of sale supplied at the time of order acknowledgment.

TI warrants performance of its components to the specifications applicable at the time of sale, in accordance with the warranty in TI's terms and conditions of sale of semiconductor products. Testing and other quality control techniques are used to the extent TI deems necessary to support this warranty. Except where mandated by applicable law, testing of all parameters of each component is not necessarily performed.

TI assumes no liability for applications assistance or the design of Buyers' products. Buyers are responsible for their products and applications using TI components. To minimize the risks associated with Buyers' products and applications, Buyers should provide adequate design and operating safeguards.

TI does not warrant or represent that any license, either express or implied, is granted under any patent right, copyright, mask work right, or other intellectual property right relating to any combination, machine, or process in which TI components or services are used. Information published by TI regarding third-party products or services does not constitute a license to use such products or services or a warranty or endorsement thereof. Use of such information may require a license from a third party under the patents or other intellectual property of the third party, or a license from TI under the patents or other intellectual property of TI.

Reproduction of significant portions of TI information in TI data books or data sheets is permissible only if reproduction is without alteration and is accompanied by all associated warranties, conditions, limitations, and notices. TI is not responsible or liable for such altered documentation. Information of third parties may be subject to additional restrictions.

Resale of TI components or services with statements different from or beyond the parameters stated by TI for that component or service voids all express and any implied warranties for the associated TI component or service and is an unfair and deceptive business practice. TI is not responsible or liable for any such statements.

Buyer acknowledges and agrees that it is solely responsible for compliance with all legal, regulatory and safety-related requirements concerning its products, and any use of TI components in its applications, notwithstanding any applications-related information or support that may be provided by TI. Buyer represents and agrees that it has all the necessary expertise to create and implement safeguards which anticipate dangerous consequences of failures, monitor failures and their consequences, lessen the likelihood of failures that might cause harm and take appropriate remedial actions. Buyer will fully indemnify TI and its representatives against any damages arising out of the use of any TI components in safety-critical applications.

In some cases, TI components may be promoted specifically to facilitate safety-related applications. With such components, TI's goal is to help enable customers to design and create their own end-product solutions that meet applicable functional safety standards and requirements. Nonetheless, such components are subject to these terms.

No TI components are authorized for use in FDA Class III (or similar life-critical medical equipment) unless authorized officers of the parties have executed a special agreement specifically governing such use.

Only those TI components which TI has specifically designated as military grade or "enhanced plastic" are designed and intended for use in military/aerospace applications or environments. Buyer acknowledges and agrees that any military or aerospace use of TI components which have **not** been so designated is solely at the Buyer's risk, and that Buyer is solely responsible for compliance with all legal and regulatory requirements in connection with such use.

TI has specifically designated certain components as meeting ISO/TS16949 requirements, mainly for automotive use. In any case of use of non-designated products, TI will not be responsible for any failure to meet ISO/TS16949.

Products

Audio	www.ti.com/audio
Amplifiers	amplifier.ti.com
Data Converters	dataconverter.ti.com
DLP® Products	www.dlp.com
DSP	dsp.ti.com
Clocks and Timers	www.ti.com/clocks
Interface	interface.ti.com
Logic	logic.ti.com
Power Mgmt	power.ti.com
Microcontrollers	microcontroller.ti.com
RFID	www.ti-rfid.com
OMAP Applications Processors	www.ti.com/omap
Wireless Connectivity	www.ti.com/wirelessconnectivity

Applications

Automotive and Transportation	www.ti.com/automotive
Communications and Telecom	www.ti.com/communications
Computers and Peripherals	www.ti.com/computers
Consumer Electronics	www.ti.com/consumer-apps
Energy and Lighting	www.ti.com/energy
Industrial	www.ti.com/industrial
Medical	www.ti.com/medical
Security	www.ti.com/security
Space, Avionics and Defense	www.ti.com/space-avionics-defense
Video and Imaging	www.ti.com/video

TI E2E Community

e2e.ti.com