

Quad Reset Supervisor with Manual Reset Input

Check for Samples: [TPS386596L33](#)

FEATURES

- 4 Voltage Monitors
- Threshold Accuracy: 0.25% (Typical)
- Fixed 50ms $\overline{\text{RESET}}$ delay time
- Active Low Manual Reset Input
- Very Low Quiescent Current: 7 μA typical
- SVS-1: Fixed Threshold for monitoring 3.3V
- SVS-2/3/4 – Adjustable Threshold Down to 0.4V
- Open Drain $\overline{\text{RESET}}$ Output
- Space Saving 8-pin MSOP Package

APPLICATIONS

- Notebook / Desktop Computers
- Industrial Equipment
- Telecom, Networking Infrastructure
- Server, Storage Equipment
- DSP and Microcontroller Applications
- FPGA/ASIC Applications

DESCRIPTION

The TPS386596L33 monitors four power rails and asserts the $\overline{\text{RESET}}$ signal when any of the SENSE inputs drop below their respective thresholds. SVS-1 can be used to monitor a 3.3V nominal power supply with no external components required. SVS-2, SVS-3, and SVS-4 are adjustable using external resistors and can be used to monitor any power supply voltage higher than 0.4V. All SENSE inputs have a threshold accuracy of 0.25% (typical). The TPS386596L33 also has an active low Manual Reset ($\overline{\text{MR}}$) that can be used to assert the $\overline{\text{RESET}}$ signal as desired by the application. The open drain, active low $\overline{\text{RESET}}$ output de-asserts using a fixed 50ms delay.

The TPS386596L33 has a low quiescent current of 7 μA typical and is available in a space saving 8-pin MSOP package.

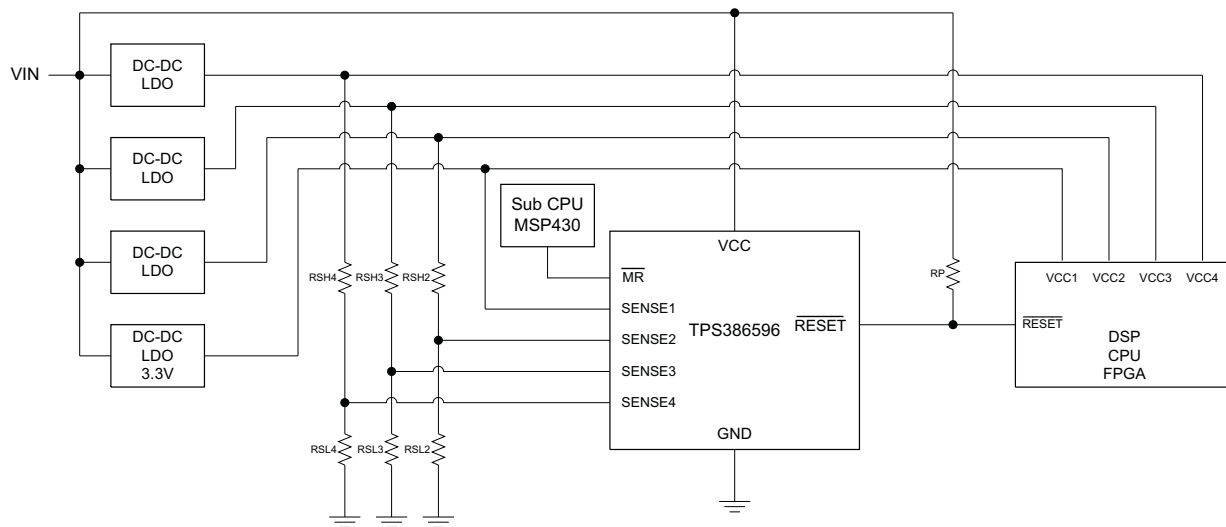

Figure 1. TPS386596L33 Typical Application Circuit



Please be aware that an important notice concerning availability, standard warranty, and use in critical applications of Texas Instruments semiconductor products and disclaimers thereto appears at the end of this data sheet.



These devices have limited built-in ESD protection. The leads should be shorted together or the device placed in conductive foam during storage or handling to prevent electrostatic damage to the MOS gates.

ORDERING INFORMATION

For the most current package and ordering information, see the Package Option Addendum at the end of this document, or see the TI Web site at www.ti.com.

Custom threshold voltages from 0.80V to 4.6V, 4.8V to 6.0V are available through the use of factory EEPROM programming. Minimum order quantities apply. Contact factory for details and availability.

ABSOLUTE MAXIMUM RATINGS

over operating free-air temperature range (unless otherwise noted)⁽¹⁾ ⁽²⁾

	TPS386596	UNIT
Input voltage range, VCC	–0.3 to 7.0	V
Other voltage ranges: V _{MR} , V _{SENSE1} , V _{SENSE2} , V _{SENSE3} , V _{SENSE4} , V _{RESET}	–0.3 to 7.0	V
$\overline{\text{RESET}}$ pin current	5	mA
ESD rating, HBM	2	kV
ESD rating, CDM	500	V
Continuous total power dissipation	See Thermal Information Table	
Operating virtual junction temperature range, T _J	–40 to 150	°C
Operating ambient temperature range, T _A	–40 to 125	°C
Storage temperature range, T _{stg}	–65 to 150	°C

- (1) Stresses beyond those listed under *Absolute maximum ratings* may cause permanent damage to the device. These are stress ratings only, and functional operation of the device at these or any other conditions beyond those indicated under *recommended operating conditions* is not implied. Exposure to absolute–maximum–rated conditions for extended periods may affect device reliability.
- (2) As a result of the low dissipated power in this device, it is assumed that T_J = T_A

THERMAL INFORMATION

THERMAL METRIC ⁽¹⁾		TPS386596	UNITS
		DGK (8 PINS)	
θ _{JA}	Junction-to-ambient thermal resistance	183.8	°C/W
θ _{JCtop}	Junction-to-case (top) thermal resistance	70.7	
θ _{JB}	Junction-to-board thermal resistance	72.8	
ψ _{JT}	Junction-to-top characterization parameter	4.9	
ψ _{JB}	Junction-to-board characterization parameter	68.4	
θ _{JCbot}	Junction-to-case (bottom) thermal resistance	n/a	

- (1) For more information about traditional and new thermal metrics, see the *IC Package Thermal Metrics* application report, [SPRA953](http://www.ti.com/lit/zip/SPR4953).

ELECTRICAL CHARACTERISTICS

Over the operating temperature range of $T_J = -40^{\circ}\text{C}$ to $+125^{\circ}\text{C}$. $1.8\text{V} < \text{VCC} < 6.5\text{V}$, $R_{\text{RESET}} = 100\text{k}\Omega$ to VCC, $C_{\text{RESET}} = 50\text{pF}$ to GND, unless otherwise noted. Typical values are at $T_J = +25^{\circ}\text{C}$.

PARAMETER		TEST CONDITIONS	MIN	TYP	MAX	UNIT
V_{VCC}	Input supply range		1.8		6.5	V
I_{VCC}	VCC Supply current (current into VCC pin)	$V_{\text{CC}} = 3.3\text{V}$, $\overline{\text{RESET}}$ not asserted		7	19	μA
		$V_{\text{CC}} = 6.5\text{V}$, $\overline{\text{RESET}}$ not asserted		7.5	22	μA
	Power-up Reset Voltage ^{(1) (2)}	$V_{\text{OL(max)}} = 0.2\text{V}$, $I_{\text{RESET}} = 15\mu\text{A}$			0.9	V
V_{ITn}	Negative-going Input Threshold Accuracy	SENSE1	2.87	2.90	2.93	V
		SENSE2, SENSE3, SENSE4	396	400	404	mV
V_{HYS}	Hysteresis (Positive-going) on VIT pin	SENSE1		25	72	mV
		SENSE2, SENSE3, SENSE4		3.5	10	mV
t_w	Input pulse width to SENSEn and $\overline{\text{MR}}$ pins	SENSEn: $1.05V_{\text{IT}} \geq 0.95V_{\text{IT}}$		4		μs
		$\overline{\text{MR}}$: $0.7V_{\text{CC}} \geq 0.3V_{\text{CC}}$		50		ns
I_{SENSE1}	Input Current at SENSE1	$V_{\text{SENSE1}} = 3.3\text{V}$	2.2	2.75	3.3	μA
I_{SENSEn}	Input Current at SENSEn pin, n = 2, 3, 4	$V_{\text{SENSEn}} = 0.42\text{V}$	-25		25	nA
t_d	$\overline{\text{RESET}}$ delay time		30	50	70	ms
V_{IL}	$\overline{\text{MR}}$ logic low input		0		$0.3V_{\text{CC}}$	V
V_{IH}	$\overline{\text{MR}}$ logic high input		$0.7V_{\text{CC}}$			V
$R_{\text{MR_Pullup}}$	Internal pullup resistor on $\overline{\text{MR}}$ pin to VCC			100		k Ω
V_{OL}	Low-level $\overline{\text{RESET}}$ output voltage	$I_{\text{OL}} = 1\text{mA}$			0.4	V
		SENSEn = 0V, $1.3\text{V} < V_{\text{CC}} < 1.8\text{V}$, $I_{\text{OL}} = 0.4\text{mA}$ ⁽¹⁾			0.3	
I_{LKG}	$\overline{\text{RESET}}$ Leakage Current	$V_{\text{RESET}} = 6.5\text{V}$, $\overline{\text{RESET}}$ not asserted	-300		300	nA
C_{IN}	Input pin capacitance			5		pF

(1) These specs are out of recommended VCC range and only define $\overline{\text{RESET}}$ output performance during VCC ramp up.

(2) The lowest supply voltage (VCC) at which $\overline{\text{RESET}}$ becomes active. $\text{Trise}(V_{\text{DD}}) \geq 15\mu\text{s/V}$.

FUNCTIONAL BLOCK DIAGRAM

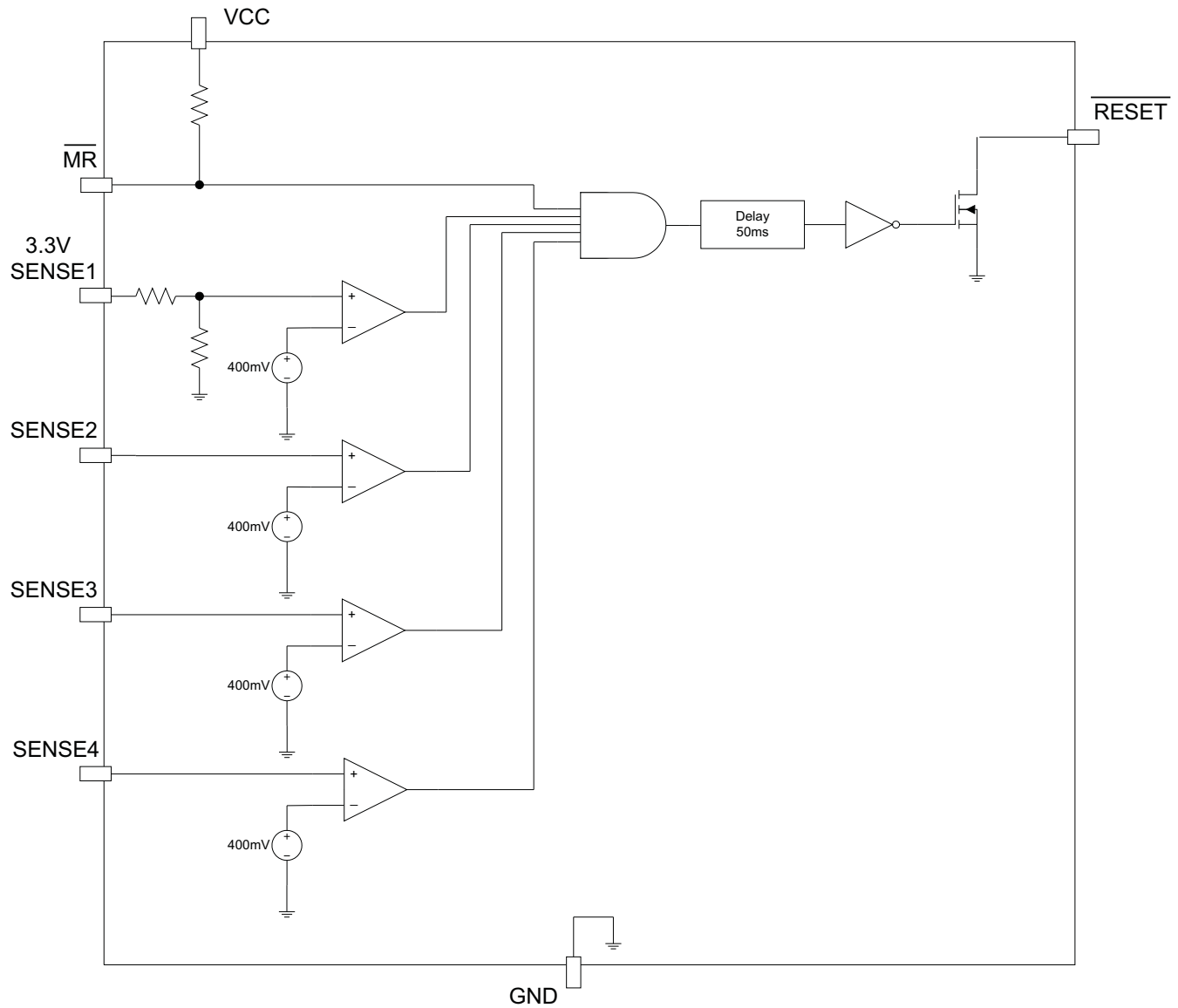
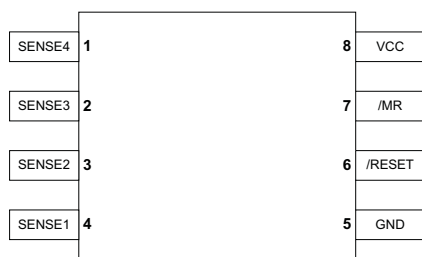

Figure 2. TPS386596L33 Block Diagram

DEVICE INFORMATION

PIN CONFIGURATION



MSOP-8

PIN FUNCTIONS

PIN		DESCRIPTION	
NAME	NO.		
SENSE1	4	Monitor voltage input for Supply 1	When the voltage at this terminal drops below the threshold voltage ($V_{IT1}=2.9V$), \overline{RESET} is asserted.
SENSE2	3	Monitor voltage input for Supply 2	When the voltage at this terminal drops below the threshold voltage ($V_{IT2}=0.4V$), \overline{RESET} is asserted.
SENSE3	2	Monitor voltage input for Supply 3	When the voltage at this terminal drops below the threshold voltage ($V_{IT3}=0.4V$), \overline{RESET} is asserted.
SENSE4	1	Monitor voltage input for Supply 4	When the voltage at this terminal drops below the threshold voltage ($V_{IT4}=0.4V$), \overline{RESET} is asserted.
\overline{MR}	7	Manual reset input with internal 100k pull-up to Vcc and 50ns deglitch. Logic low level of this pin asserts \overline{RESET} .	
\overline{RESET}	6	\overline{RESET} is an open-drain output pin. When \overline{RESET} is asserted, this pin remains in a low-impedance state. When \overline{RESET} is released, this pin goes to a high-impedance state after 50ms.	
Vcc	8	Supply voltage. Connecting a 0.1 μF ceramic capacitor close to this pin is recommended.	
GND	5	Ground	

GENERAL DESCRIPTION

The TPS386596L33 multi-channel reset supervisor provides a complete single reset function for a four power supply system. The design of the SVS is based on the TPS386000 quad supervisor device series. TPS386596 is designed to assert the \overline{RESET} signal following the logic in Table 1. The \overline{RESET} output remains asserted for a 50ms delay time after the event of reset release. The SENSE1 input has a fixed voltage threshold designed to monitor a 3.3V nominal supply. The trip point, V_{IT1} , for SENSE1 is 2.90 (TYP). Each of the remaining SENSEn inputs ($n = 2,3,4$) can be set to any voltage threshold above 0.4V using an external resistor divider. An active low manual reset (\overline{MR}) input is also provided for asserting the \overline{RESET} signal as desired by the system.

RESET OUTPUT

In a typical application of TPS386596, the \overline{RESET} output is connected to the reset input of a processor (DSP, MCU, CPU, FPGA, ASIC, etc.) or connected to the enable input of voltage regulators (DC-DC, LDO, etc.).

TPS386596 provides an open drain reset output. Pull-up resistors must be used to hold this line high when \overline{RESET} is not asserted. By connecting a pull-up resistor to the proper voltage rail (up to 6.5V), the \overline{RESET} output can be connected to other devices at the right interface voltage level. The pull-up resistor should be no smaller than 10k Ω as a result of the finite impedance of the output transistor.

The \overline{RESET} output is defined for $V_{CC} > 0.9V$. To ensure that the target processor is properly reset, the VCC supply input should be fed by the power rail which is available as early as possible in the application.

Table 1 describes a truth table of how the \overline{RESET} output is asserted or released. Figure 3 provides a timing diagram that shows how \overline{RESET} is asserted and de-asserted in relation to \overline{MR} and the SENSEn inputs. Once the conditions are met, the transitions from the asserted state to the release state are performed after a fixed 50ms delay time.

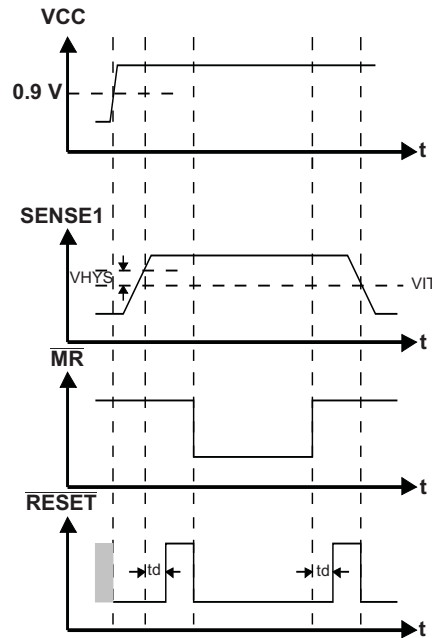

Figure 3. Timing Diagram

SENSE INPUTS

The SENSE_n inputs provide terminals at which the system voltages can be monitored. If the voltage at any one of the SENSE_n pins drops below their respective V_{ITn} , then the \overline{RESET} output is asserted. The comparators have a built-in hysteresis to ensure smooth \overline{RESET} transitions. It is good analog design practice to use a 1nF to 10nF bypass capacitor at the SENSE_n input to ground, to reduce sensitivity to transients, layout parasitics, and interference between power rails monitored by this device.

A typical connection of resistor dividers is show in Figure 4. SENSE1 is used to monitor a 3.3V nominal power supply voltage with a trip point = 2.90V, and the remaining SENSE_n (n=2,3,4) inputs can be used to monitor voltage rails down to 0.4V. Threshold voltages can be calculated using the following equations.

$$VCC2_target = (1 + RS2H/RS2L) \times 0.4 \text{ (V)}$$

$$VCC3_target = (1 + RS3H/RS3L) \times 0.4 \text{ (V)}$$

$$VCC4_target = (1 + RS4H/RS4L) \times 0.4 \text{ (V)}$$

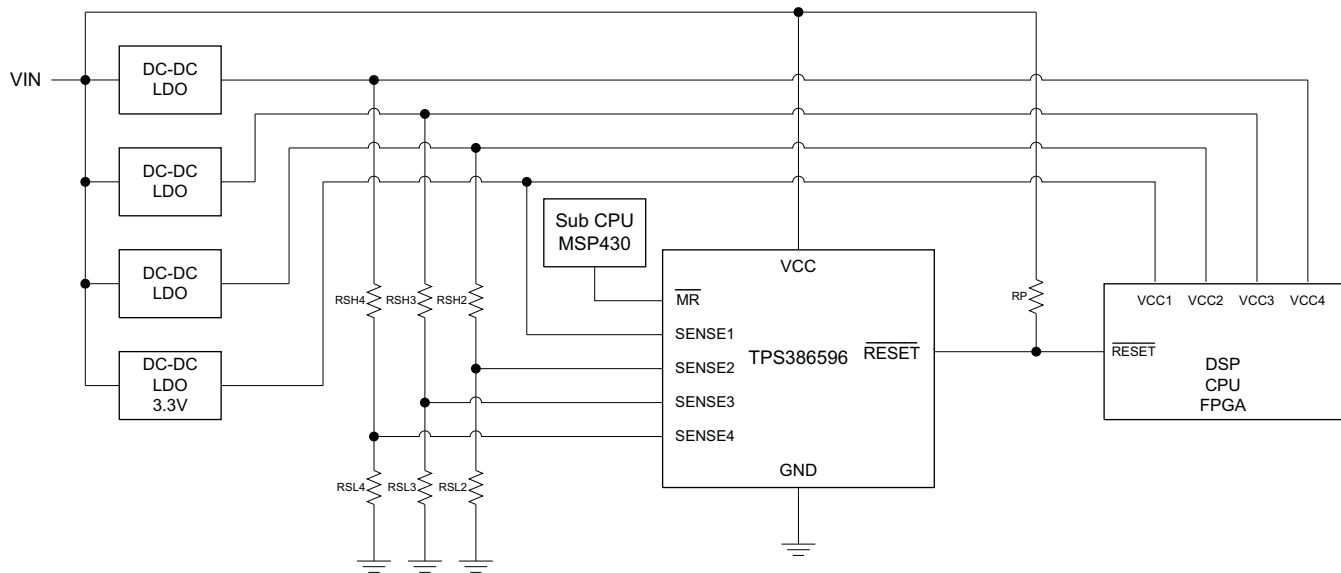

Figure 4. Typical TPS386596L33 Application Diagram

MANUAL RESET

The manual reset \overline{MR} input allows external logic signal from processors, other logic circuits, and/or discrete sensors to initiate a reset. The typical application of a TPS386596 has its \overline{RESET} output connected to processor. A logic low at \overline{MR} causes \overline{RESET} to assert. After \overline{MR} returns to a logic high and \overline{SENSEn} are above their respective voltage thresholds, \overline{RESET} is released after a fixed 50ms reset delay time. An internal 100k Ω pull-up to V_{CC} is integrated on the \overline{MR} input. There is also an internal 50ns (typical) deglitch circuit.

Table 1. \overline{RESET} Truth Table

CONDITION		OUTPUT	
$\overline{MR} = L$	$\overline{SENSEn} < VITn$	$\overline{RESET} = L$	Reset asserted
$\overline{MR} = L$	$\overline{SENSEn} > VITn$	$\overline{RESET} = L$	Reset asserted
$\overline{MR} = H$	$\overline{SENSE1} < VIT1$ OR $\overline{SENSE2} < VIT2$ OR $\overline{SENSE3} < VIT3$ OR $\overline{SENSE4} < VIT4$	$\overline{RESET} = L$	Reset asserted
$\overline{MR} = H$	$\overline{SENSE1} > VIT1$ AND $\overline{SENSE2} > VIT2$ AND $\overline{SENSE3} > VIT3$ AND $\overline{SENSE4} > VIT4$	$\overline{RESET} = H$	Reset released

IMMUNITY TO SENSE PIN VOLTAGE TRANSIENTS

The TPS386596 is relatively immune to short negative transients on the \overline{SENSEn} pins. Sensitivity to transients is dependent on how much percentage the sense voltage drops below the threshold voltage, as shown in Figure 8. See Figure 5 for the measurement technique.

PARAMETRIC MEASUREMENT INFORMATION

TEST CONDITION

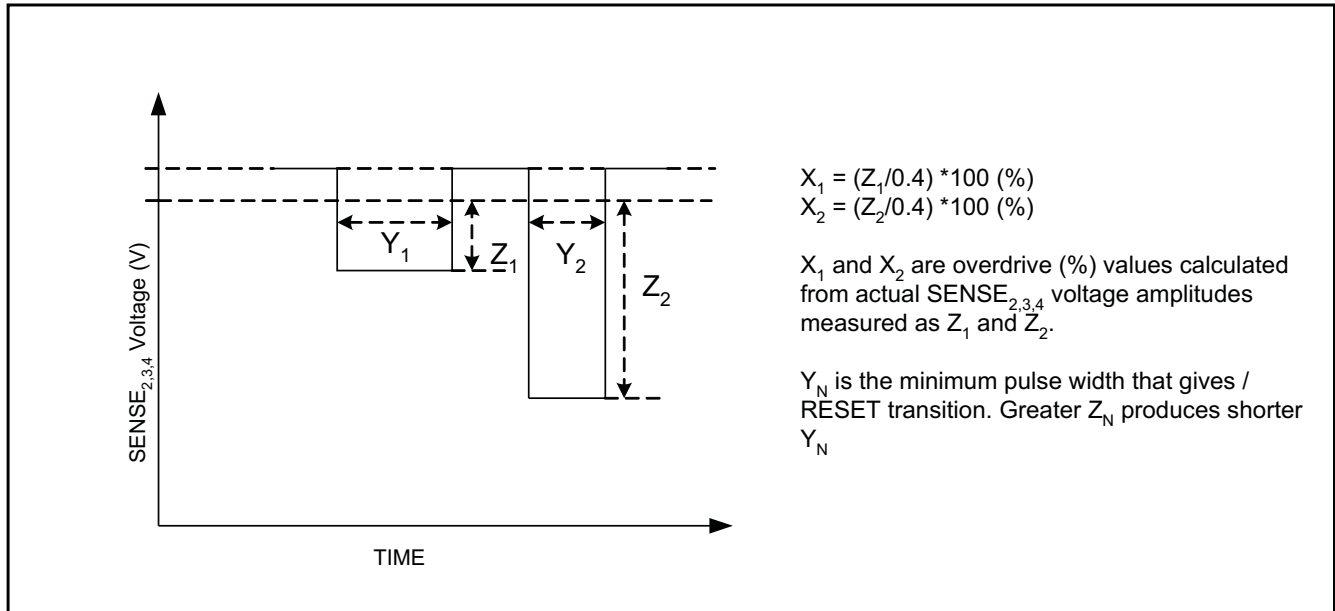

Figure 5. Measurement Technique for Immunity to Sense Pin Voltage Transient

TYPICAL CHARACTERISTICS

At $T_A = +25^\circ\text{C}$, and $V_{CC} = 3.3\text{V}$, unless otherwise noted.

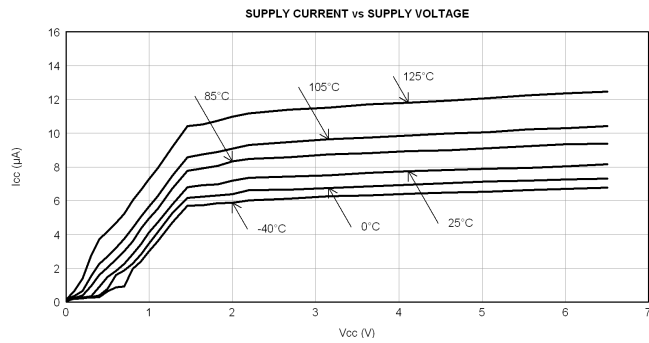

Figure 6.

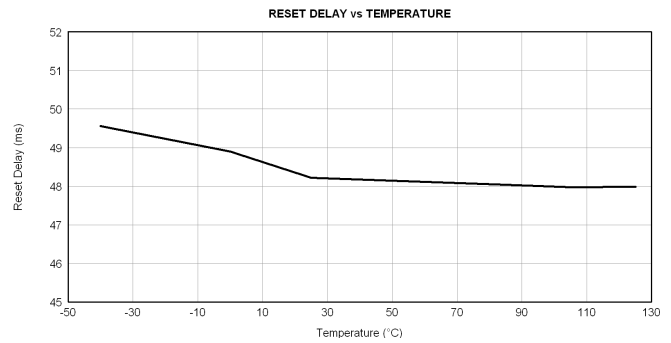

Figure 7.

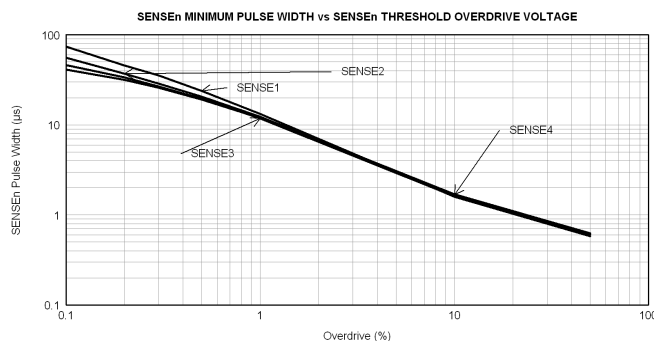

Figure 8.

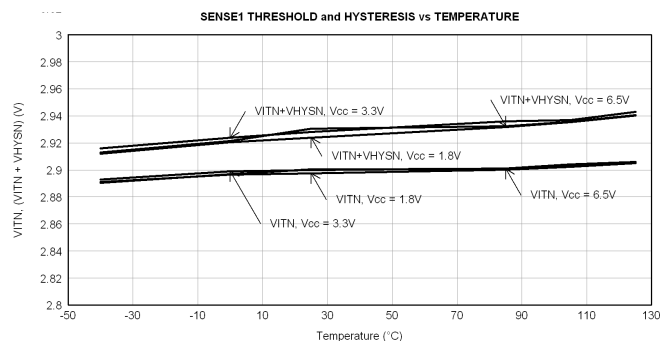

Figure 9.

TYPICAL CHARACTERISTICS (continued)

At $T_A = +25^\circ\text{C}$, and $V_{CC} = 3.3\text{V}$, unless otherwise noted.

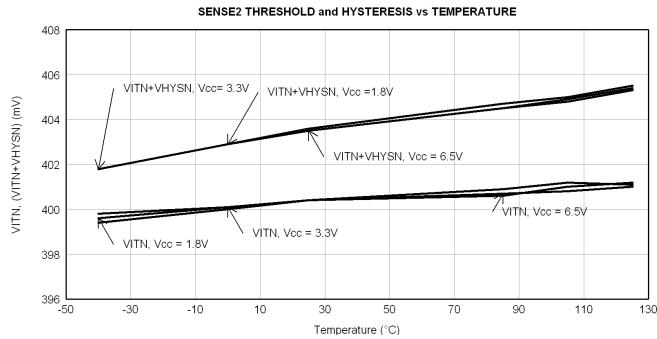

Figure 10.

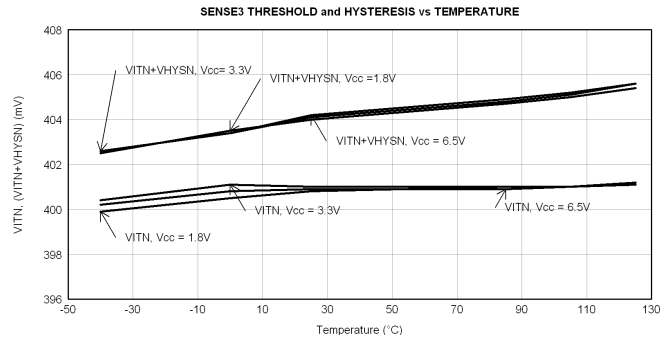

Figure 11.

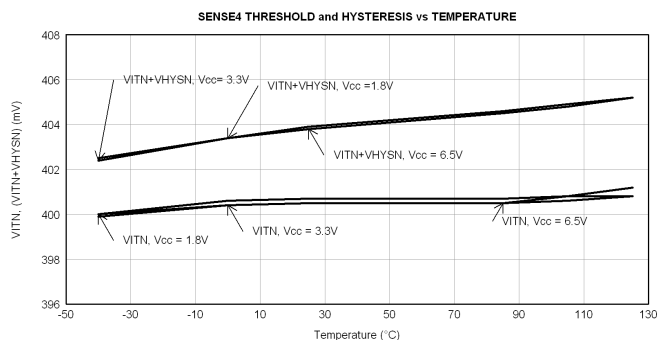

Figure 12.

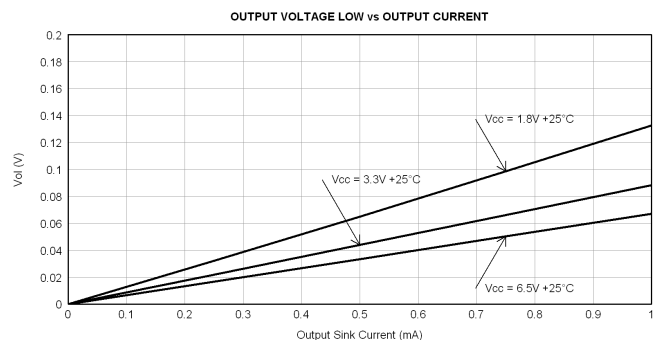

Figure 13.

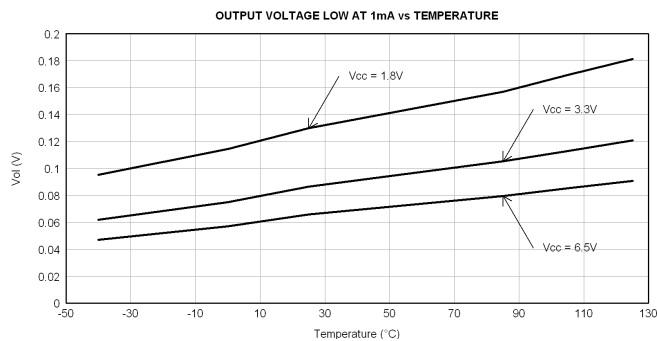

Figure 14.

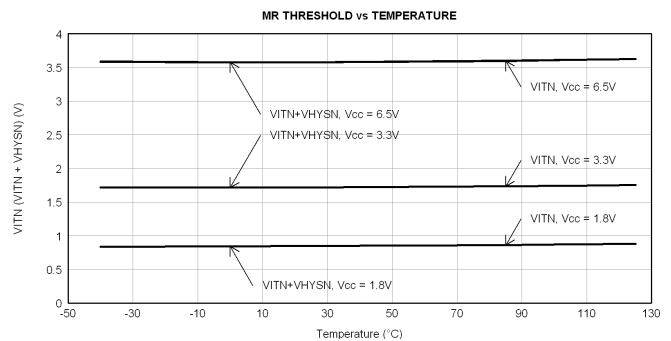

Figure 15.

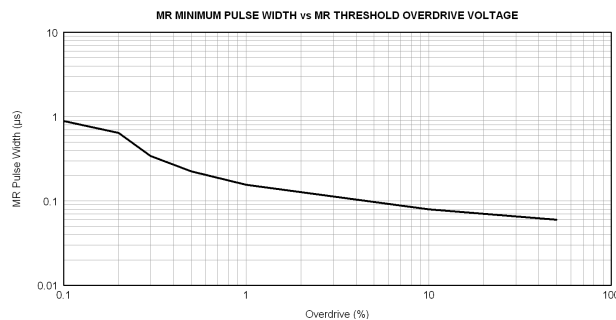

Figure 16.

PACKAGING INFORMATION

Orderable Device	Status ⁽¹⁾	Package Type	Package Drawing	Pins	Package Qty	Eco Plan ⁽²⁾	Lead/ Ball Finish	MSL Peak Temp ⁽³⁾	Samples (Requires Login)
TPS386596L33DGKR	ACTIVE	VSSOP	DGK	8	2500	Green (RoHS & no Sb/Br)	CU NIPDAU	Level-2-260C-1 YEAR	
TPS386596L33DGKT	ACTIVE	VSSOP	DGK	8	250	Green (RoHS & no Sb/Br)	CU NIPDAU	Level-2-260C-1 YEAR	

⁽¹⁾ The marketing status values are defined as follows:

ACTIVE: Product device recommended for new designs.

LIFEBUY: TI has announced that the device will be discontinued, and a lifetime-buy period is in effect.

NRND: Not recommended for new designs. Device is in production to support existing customers, but TI does not recommend using this part in a new design.

PREVIEW: Device has been announced but is not in production. Samples may or may not be available.

OBSOLETE: TI has discontinued the production of the device.

⁽²⁾ Eco Plan - The planned eco-friendly classification: Pb-Free (RoHS), Pb-Free (RoHS Exempt), or Green (RoHS & no Sb/Br) - please check <http://www.ti.com/productcontent> for the latest availability information and additional product content details.

TBD: The Pb-Free/Green conversion plan has not been defined.

Pb-Free (RoHS): TI's terms "Lead-Free" or "Pb-Free" mean semiconductor products that are compatible with the current RoHS requirements for all 6 substances, including the requirement that lead not exceed 0.1% by weight in homogeneous materials. Where designed to be soldered at high temperatures, TI Pb-Free products are suitable for use in specified lead-free processes.

Pb-Free (RoHS Exempt): This component has a RoHS exemption for either 1) lead-based flip-chip solder bumps used between the die and package, or 2) lead-based die adhesive used between the die and leadframe. The component is otherwise considered Pb-Free (RoHS compatible) as defined above.

Green (RoHS & no Sb/Br): TI defines "Green" to mean Pb-Free (RoHS compatible), and free of Bromine (Br) and Antimony (Sb) based flame retardants (Br or Sb do not exceed 0.1% by weight in homogeneous material)

⁽³⁾ MSL, Peak Temp. -- The Moisture Sensitivity Level rating according to the JEDEC industry standard classifications, and peak solder temperature.

Important Information and Disclaimer: The information provided on this page represents TI's knowledge and belief as of the date that it is provided. TI bases its knowledge and belief on information provided by third parties, and makes no representation or warranty as to the accuracy of such information. Efforts are underway to better integrate information from third parties. TI has taken and continues to take reasonable steps to provide representative and accurate information but may not have conducted destructive testing or chemical analysis on incoming materials and chemicals. TI and TI suppliers consider certain information to be proprietary, and thus CAS numbers and other limited information may not be available for release.

In no event shall TI's liability arising out of such information exceed the total purchase price of the TI part(s) at issue in this document sold by TI to Customer on an annual basis.

TAPE AND REEL INFORMATION
REEL DIMENSIONS

TAPE DIMENSIONS

A0	Dimension designed to accommodate the component width
B0	Dimension designed to accommodate the component length
K0	Dimension designed to accommodate the component thickness
W	Overall width of the carrier tape
P1	Pitch between successive cavity centers

TAPE AND REEL INFORMATION

*All dimensions are nominal

Device	Package Type	Package Drawing	Pins	SPQ	Reel Diameter (mm)	Reel Width W1 (mm)	A0 (mm)	B0 (mm)	K0 (mm)	P1 (mm)	W (mm)	Pin1 Quadrant
TPS386596L33DGKR	VSSOP	DGK	8	2500	330.0	12.4	5.3	3.3	1.3	8.0	12.0	Q1
TPS386596L33DGKT	VSSOP	DGK	8	250	180.0	12.4	5.3	3.3	1.3	8.0	12.0	Q1

TAPE AND REEL BOX DIMENSIONS



*All dimensions are nominal

Device	Package Type	Package Drawing	Pins	SPQ	Length (mm)	Width (mm)	Height (mm)
TPS386596L33DGKR	VSSOP	DGK	8	2500	370.0	355.0	55.0
TPS386596L33DGKT	VSSOP	DGK	8	250	195.0	200.0	45.0

DGK (S-PDSO-G8)

PLASTIC SMALL-OUTLINE PACKAGE



4073329/E 05/06

- NOTES:
- A. All linear dimensions are in millimeters.
 - B. This drawing is subject to change without notice.
 - C. Body length does not include mold flash, protrusions, or gate burrs. Mold flash, protrusions, or gate burrs shall not exceed 0.15 per end.
 - D. Body width does not include interlead flash. Interlead flash shall not exceed 0.50 per side.
 - E. Falls within JEDEC MO-187 variation AA, except interlead flash.

IMPORTANT NOTICE

Texas Instruments Incorporated and its subsidiaries (TI) reserve the right to make corrections, enhancements, improvements and other changes to its semiconductor products and services per JESD46C and to discontinue any product or service per JESD48B. Buyers should obtain the latest relevant information before placing orders and should verify that such information is current and complete. All semiconductor products (also referred to herein as "components") are sold subject to TI's terms and conditions of sale supplied at the time of order acknowledgment.

TI warrants performance of its components to the specifications applicable at the time of sale, in accordance with the warranty in TI's terms and conditions of sale of semiconductor products. Testing and other quality control techniques are used to the extent TI deems necessary to support this warranty. Except where mandated by applicable law, testing of all parameters of each component is not necessarily performed.

TI assumes no liability for applications assistance or the design of Buyers' products. Buyers are responsible for their products and applications using TI components. To minimize the risks associated with Buyers' products and applications, Buyers should provide adequate design and operating safeguards.

TI does not warrant or represent that any license, either express or implied, is granted under any patent right, copyright, mask work right, or other intellectual property right relating to any combination, machine, or process in which TI components or services are used. Information published by TI regarding third-party products or services does not constitute a license to use such products or services or a warranty or endorsement thereof. Use of such information may require a license from a third party under the patents or other intellectual property of the third party, or a license from TI under the patents or other intellectual property of TI.

Reproduction of significant portions of TI information in TI data books or data sheets is permissible only if reproduction is without alteration and is accompanied by all associated warranties, conditions, limitations, and notices. TI is not responsible or liable for such altered documentation. Information of third parties may be subject to additional restrictions.

Resale of TI components or services with statements different from or beyond the parameters stated by TI for that component or service voids all express and any implied warranties for the associated TI component or service and is an unfair and deceptive business practice. TI is not responsible or liable for any such statements.

Buyer acknowledges and agrees that it is solely responsible for compliance with all legal, regulatory and safety-related requirements concerning its products, and any use of TI components in its applications, notwithstanding any applications-related information or support that may be provided by TI. Buyer represents and agrees that it has all the necessary expertise to create and implement safeguards which anticipate dangerous consequences of failures, monitor failures and their consequences, lessen the likelihood of failures that might cause harm and take appropriate remedial actions. Buyer will fully indemnify TI and its representatives against any damages arising out of the use of any TI components in safety-critical applications.

In some cases, TI components may be promoted specifically to facilitate safety-related applications. With such components, TI's goal is to help enable customers to design and create their own end-product solutions that meet applicable functional safety standards and requirements. Nonetheless, such components are subject to these terms.

No TI components are authorized for use in FDA Class III (or similar life-critical medical equipment) unless authorized officers of the parties have executed a special agreement specifically governing such use.

Only those TI components which TI has specifically designated as military grade or "enhanced plastic" are designed and intended for use in military/aerospace applications or environments. Buyer acknowledges and agrees that any military or aerospace use of TI components which have **not** been so designated is solely at the Buyer's risk, and that Buyer is solely responsible for compliance with all legal and regulatory requirements in connection with such use.

TI has specifically designated certain components which meet ISO/TS16949 requirements, mainly for automotive use. Components which have not been so designated are neither designed nor intended for automotive use; and TI will not be responsible for any failure of such components to meet such requirements.

Products

Audio	www.ti.com/audio
Amplifiers	amplifier.ti.com
Data Converters	dataconverter.ti.com
DLP® Products	www.dlp.com
DSP	dsp.ti.com
Clocks and Timers	www.ti.com/clocks
Interface	interface.ti.com
Logic	logic.ti.com
Power Mgmt	power.ti.com
Microcontrollers	microcontroller.ti.com
RFID	www.ti-rfid.com
OMAP Mobile Processors	www.ti.com/omap
Wireless Connectivity	www.ti.com/wirelessconnectivity

Applications

Automotive and Transportation	www.ti.com/automotive
Communications and Telecom	www.ti.com/communications
Computers and Peripherals	www.ti.com/computers
Consumer Electronics	www.ti.com/consumer-apps
Energy and Lighting	www.ti.com/energy
Industrial	www.ti.com/industrial
Medical	www.ti.com/medical
Security	www.ti.com/security
Space, Avionics and Defense	www.ti.com/space-avionics-defense
Video and Imaging	www.ti.com/video

TI E2E Community e2e.ti.com