

IEEE 802.3at PoE High-Power PD Interface with External Gate Driver

Check for Samples: [TPS2379](#)

FEATURES

- IEEE 802.3at Type-2 Hardware Classification with Status Flag
- Auxiliary Gate Driver for High-power Expansion
- Robust 100 V, 0.5 Ω Hotswap MOSFET
- 1A (typ.) Operating Current Limit
- 140 mA (typ.) Inrush Current Limit
- DC/DC Converter Enable
- 15 kV/8 kV System-level ESD Capability
- PowerPad™ SO-8 Package

APPLICATIONS

- IEEE 802.3at-compliant Devices
- Universal Power Over Ethernet (UPOE) Compliant Devices
- Video and VoIP Telephones
- Multiband Access Points
- Security Cameras
- Pico-Base Stations

DESCRIPTION

This 8-pin integrated circuit contains all of the features needed to implement an IEEE802.3at type-2 powered device (PD). The low 0.5 Ω internal switch resistance, combined with the enhanced thermal dissipation of the PowerPad™ package, enables this controller to continuously handle up to 0.85 A. The TPS2379 supports higher-power applications through the use of an external pass transistor. It also features a 100 V internal pass transistor, 140 mA inrush current, type-2 indication, auto-retry fault protection, and an open-drain power-good output.

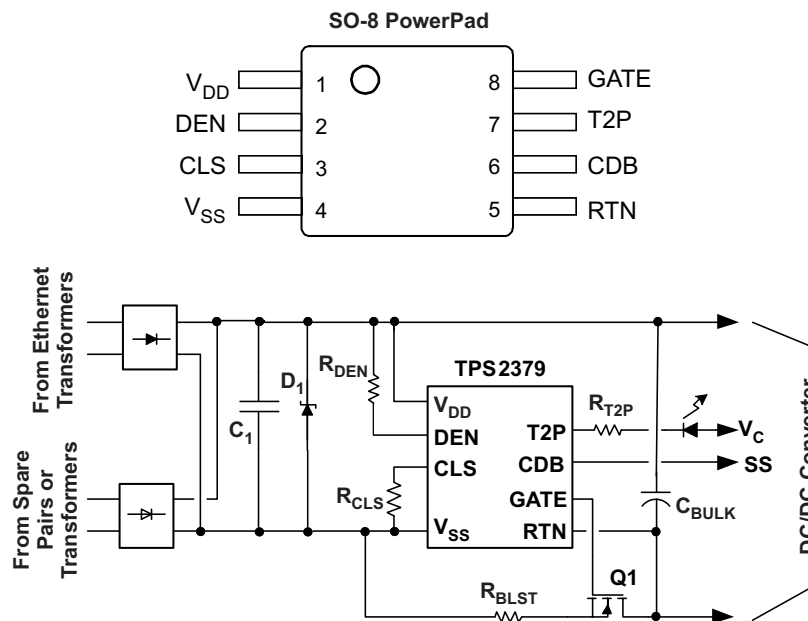

Figure 1. Typical Application



Please be aware that an important notice concerning availability, standard warranty, and use in critical applications of Texas Instruments semiconductor products and disclaimers thereto appears at the end of this data sheet.

PowerPad, PowerPAD are trademarks of Texas Instruments.



These devices have limited built-in ESD protection. The leads should be shorted together or the device placed in conductive foam during storage or handling to prevent electrostatic damage to the MOS gates.

PRODUCT INFORMATION⁽¹⁾

DEVICE	T _A	PACKAGE	MARKING
TPS2379	–40°C to 85°C	DDA (SO-8 PowerPAD™)	2379

(1) For the most current package and ordering information, see the Package Option Addendum at the end of this document, or see the TI website at www.ti.com.

ABSOLUTE MAXIMUM RATINGS⁽¹⁾

over recommended T_J range; voltages with respect to V_{VSS} (unless otherwise noted)

		VALUE		UNIT
		MIN	MAX	
Input voltage	V _{DD} , DEN	–0.3	100	V
	RTN ⁽²⁾	–0.6	100	
	CLS ⁽³⁾	–0.3	6.5	
	GATE ⁽³⁾	–0.3	18	
	[CDB, T2P] to RTN	–0.3	100	
Sinking current	RTN ⁽⁴⁾	Internally limited		mA
	CDB, T2P		5	
	DEN		1	
Sourcing current	CLS		65	mA
ESD	Human body model		2	kV
	Charged device model		500	V
	System level (contact/air) ⁽⁵⁾	8	15	kV
T _{JMAX}		Internally limited		°C

- (1) Stresses beyond those listed under “absolute maximum ratings” may cause permanent damage to the device. These are stress ratings only and functional operation of the device at these or any other conditions beyond those indicated under “recommended operating conditions” is not implied. Exposure to absolute-maximum-rated conditions for extended periods may affect device reliability.
- (2) With I(RTN) = 0
- (3) Do not apply voltages to these pins
- (4) SOA limited to RTN = 80 V at 1.2 A.
- (5) Discharges applied to circuit of [Figure 1](#) between RJ-45, adapter, and output voltage rails per EN61000-4-2, 1999.

THERMAL INFORMATION

THERMAL METRIC ⁽¹⁾		TPS2379	UNITS
		SO-8 PowerPad™	
		8 PINS	
θ _{JA}	Junction-to-ambient thermal resistance	45.9	°C/W
θ _{JCtop}	Junction-to-case (top) thermal resistance	51.9	
θ _{JB}	Junction-to-board thermal resistance	28.8	
ψ _{JT}	Junction-to-top characterization parameter	8.9	
ψ _{JB}	Junction-to-board characterization parameter	28.7	
θ _{JCbot}	Junction-to-case (bottom) thermal resistance	6.7	

(1) For more information about traditional and new thermal metrics, see the *IC Package Thermal Metrics* application report, [SPRA953](#).

RECOMMENDED OPERATING CONDITIONS

Voltages with respect to V_{SS} (unless otherwise noted)

		MIN	NOM	MAX	UNIT
Input voltage range	RTN, V_{DD}	0		57	V
	T2P or CDB to RTN	0		57	
Sinking current	RTN			0.85	A
	CDB, T2P			2	mA
Resistance	CLS ⁽¹⁾	60			Ω
Junction temperature		-40		125	$^{\circ}\text{C}$

(1) Voltage should not be externally applied to this pin.

ELECTRICAL CHARACTERISTICS

40 V $\leq V_{DD} \leq 57$ V, $R_{DEN} = 24.9$ k Ω , CDB, CLS, GATE, T2P open; $-40^{\circ}\text{C} \leq T_J \leq 125^{\circ}\text{C}$. Positive currents are into pins. Typical values are at 25 $^{\circ}\text{C}$. All voltages are with respect to V_{VSS} (unless otherwise noted)

PARAMETER		TEST CONDITIONS			MIN	TYP	MAX	UNIT	
DETECTION (DEN)									
Detection current	Measure $I_{SUPPLY}(V_{DD}, RTN, DEN)$							μA	
	$V_{DD} = 1.4$ V		53.8	56.5	58.3				
	$V_{DD} = 10.1$ V, Not in mark		395	410	417				
Bias current		DEN open, $V_{VDD} = 10.1$ V, Measure I_{SUPPLY} , Not in mark			3	4.8	12	μA	
V_{PD_DIS}	Disable threshold		DEN falling			3	3.7	5	V
	Hysteresis					50	113	200	mV
CLASSIFICATION (CLS)									
I_{CLS}	Classification current	13 V $\leq V_{DD} \leq 21$ V, Measure $I_{VDD} + I_{DEN} + I_{RTN}$						mA	
		$R_{CLS} = 1270$ Ω		1.8	2.17	2.6			
		$R_{CLS} = 243$ Ω		9.9	10.6	11.2			
		$R_{CLS} = 137$ Ω		17.6	18.6	19.4			
		$R_{CLS} = 90.9$ Ω		26.5	27.9	29.3			
		$R_{CLS} = 63.4$ Ω		38	39.9	42.0			
V_{CL_ON}	Class lower threshold	V_{DD} rising, $V_{CLS} \uparrow$			11.9	12.5	13.0	V	
V_{CL_H}		Hysteresis			1.4	1.6	1.7		
V_{CU_ON}	Class upper threshold	V_{DD} rising, $V_{CLS} \downarrow$			21	22	23	V	
V_{CU_H}		Hysteresis			0.5	0.78	0.9		
V_{MSR}	Mark reset threshold		V_{VDD} falling			3	3.9	5	
Mark state resistance		2-point measurement at 5 V and 10.1 V			6	10	12	k Ω	
Leakage current		$V_{DD} = 57$ V, $V_{CLS} = 0$ V, measure I_{CLS}					1	μA	
GATE (Auxiliary Gate Output)									
Output high voltage					8	10	12	V	
Sourcing current		$V_{GATE} = 0$ V			25	38	60	μA	
Sinking current	$V_{GATE} = 4$ V, $V_{DD} = 48 \rightarrow 25$ V					0.6	1.25	1.75	mA
	$V_{DD} = 25$ V, $V_{GATE} = 0 \rightarrow 4$ V					5	23.2	30	
Current limit delay					150	365	600	μs	
PASS DEVICE (RTN)									
$r_{DS(ON)}$	On resistance					0.2	0.42	0.75	Ω
Input bias current		$V_{DD} = V_{RTN} = 30$ V, measure I_{RTN}					30	μA	
Current limit		$V_{RTN} = 1.5$ V			0.85	1	1.2	A	
Inrush current limit		$V_{RTN} = 2$ V, $V_{DD}: 20$ V $\rightarrow 48$ V			100	140	180	mA	

ELECTRICAL CHARACTERISTICS (continued)

40 V ≤ V_{VDD} ≤ 57 V, R_{DEN} = 24.9 kΩ, CDB, CLS, GATE, T2P open; −40°C ≤ T_J ≤ 125°C. Positive currents are into pins. Typical values are at 25°C. All voltages are with respect to V_{VSS} (unless otherwise noted)

PARAMETER	TEST CONDITIONS	MIN	TYP	MAX	UNIT
Inrush termination	Percentage of inrush current	80%	90%	99%	
Foldback threshold	V _{RTN} rising	11	12.3	13.6	V
Foldback deglitch time	V _{RTN} rising to when current limit changes to inrush current limit	500	800	1500	μs
CONVERTER DISABLE (CDB)					
Output low voltage	I _{CDB} = 2 mA, V _{RTN} = 2 V, V _{VDD} : 20 V → 48 V		0.27	0.50	V
Minimum voltage, V _(VDD-RTN) , for CDB to be valid	V _{CDB} = V _{DD} , I _{CDB} = 1 mA, in inrush		3		V
Leakage current	V _{CDB} = 57 V, V _{RTN} = 0 V			10	μA
TYPE 2 PSE INDICATION (T2P)					
V _{T2P} Output low voltage	I _{T2P} = 2 mA, after 2-event classification and inrush is complete, V _{RTN} = 0 V		0.26	0.60	V
Leakage current	V _{T2P} = 57 V, V _{RTN} = 0 V			10	μA
UVLO					
V _{UVLO_R} UVLO rising threshold	V _{VDD} rising	36.3	38.1	40.0	V
UVLO falling threshold	V _{VDD} falling	30.5	32.0	33.6	
V _{UVLO_H} UVLO hysteresis			6.1		V
THERMAL SHUTDOWN					
Shutdown	T _J ↑	135	145		°C
Hysteresis			20		
V_{DD} BIAS CURRENT					
Operating current	40 V ≤ V _{VDD} ≤ 57 V		285	500	μA

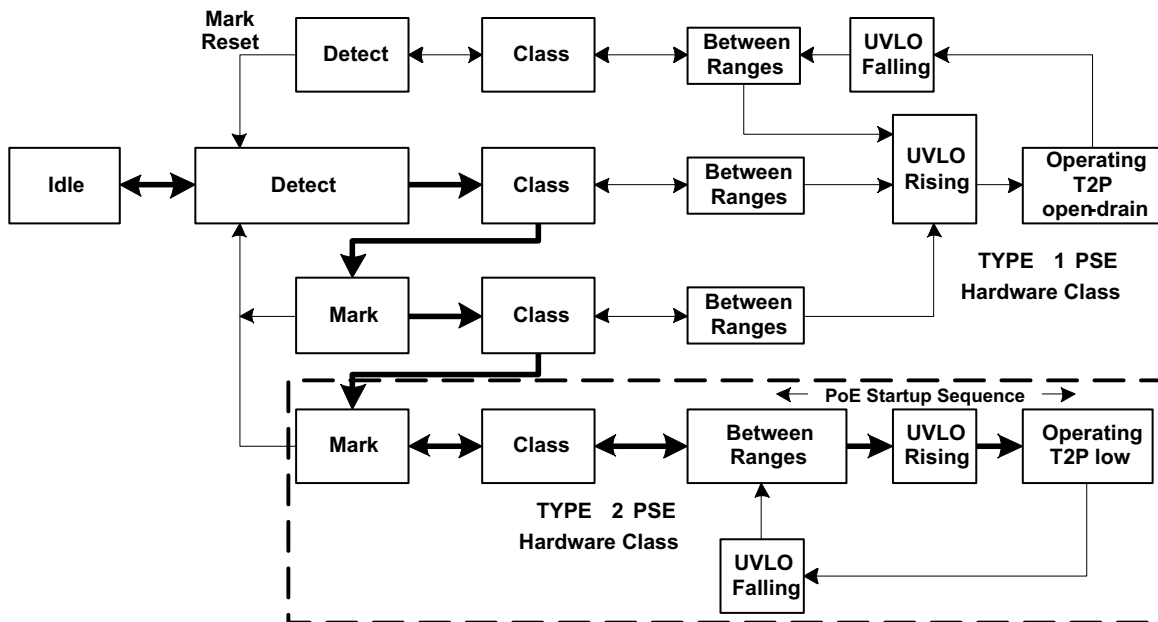
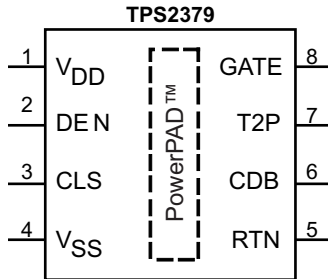
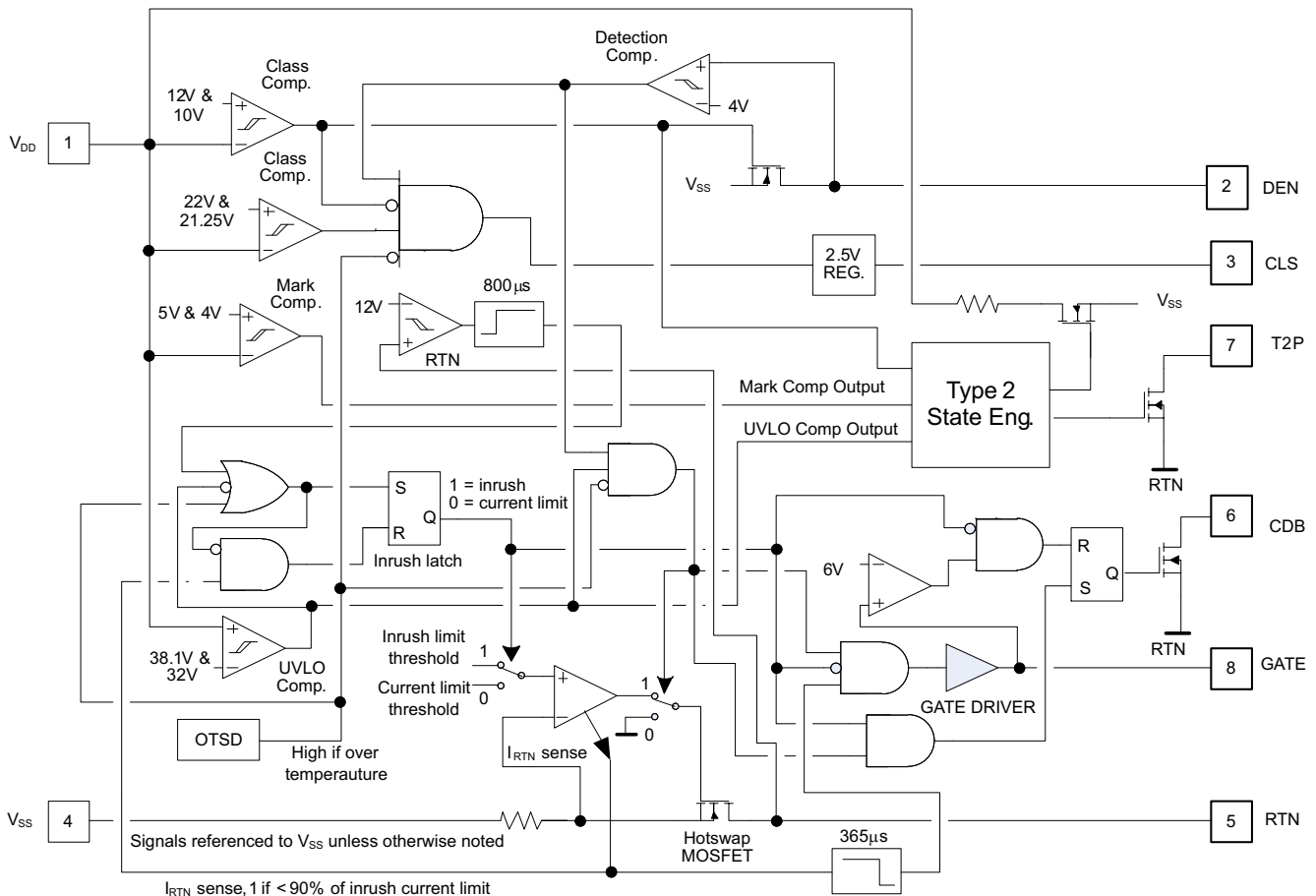

Figure 2. PD Class State Diagram



PIN FUNCTIONS

NAME	NO.	I/O	DESCRIPTION
V _{DD}	1	I	Connect to positive PoE input power rail. Bypass with 0.1 μF to V _{SS} .
DEN	2	I/O	Connect 24.9 kΩ to V _{DD} for detection. Pull to V _{SS} disable pass MOSFET.
CLS	3	O	Connect resistor from CLS to V _{SS} to program classification current.
V _{SS}	4		Connect to negative power rail derived from PoE source.
RTN	5	O	Drain of PoE pass MOSFET.
CDB	6	O	Open-drain converter disable output, active low, referenced to RTN.
T2P	7	O	Active low indicates type 2 PSE connected.
GATE	8	O	Auxiliary gate driver output.
Pad			The PowerPad™ must be connected to V _{SS} . A large fill area is required to assist in heat dissipation.



DETAILED PIN DESCRIPTIONS

The following descriptions refer to the schematic of [Figure 1](#) or [Figure 4](#) and the functional block diagram.

CDB (Converter Disble Bar): This active low output is pulled to RTN when the device is in inrush current limiting, going open when inrush period has completed once the GATE output has become higher than 6 V. This ensures that the external pass transistor is enhanced before the load is enabled. It remains in a high impedance state at all other times. This pin is an open-drain output, and it may require a pullup resistor or other interface to the downstream load. CDB may be left open if it is not used.

CLS: An external resistor (R_{CLS} in [Figure 1](#)) connected between the CLS pin and VSS provides a classification signature to the PSE. The controller places a voltage of approximately 2.5 V across the external resistor whenever the voltage differential between VDD and VSS lies between about 10.9 V and 22 V. The current drawn by this resistor, combined with the internal current drain of the controller and any leakage through the internal pass MOSFET, creates the classification current. [Table 1](#) lists the external resistor values required for each of the PD power ranges defined by IEEE802.3at. The maximum average power drawn by the PD, plus the power supplied to the downstream load, should not exceed the maximum power indicated in [Table 1](#).

High-power PSEs may perform two classification cycles if Class 4 is presented on the first cycle.

Table 1. Class Resistor Selection

CLASS	MINIMUM POWER AT PD (W)	MAXIMUM POWER AT PD (W)	RESISTOR R_{CLS} (Ω)
0	0.44	12.95	1270
1	0.44	3.84	243
2	3.84	6.49	137
3	6.49	12.95	90.9
4	12.95	25.5	63.4

DEN (Detection and Enable): This pin implements two separate functions. A resistor (R_{DEN} in [Figure 1](#)) connected between V_{DD} and DEN generates a detection signature whenever the voltage differential between V_{DD} and V_{SS} lies between approximately 1.4 and 10.9V. Beyond this range, the controller disconnects this resistor to save power. For applications that wish to comply with the requirements of IEEE802.3at, the external resistance should equal 24.9 k Ω .

If the resistance connected between V_{DD} and DEN is divided into two roughly equal portions, then the application circuit can disable the PD by grounding the tap point between the two resistances. This action simultaneously spoils the detection signature and thereby signals the PSE that the PD no longer requires power.

GATE (Auxiliary Gate Driver): This pin allows the connection of an external pass MOSFET in parallel with the internal pass transistor. The GATE pin enables the external transistor after inrush has completed. Current is divided between the external MOSFET and the internal transistor as a function of their respective resistances. The addition of a balancing resistor (R_{BLST} in [Figure 1](#)) in series with RTN and the external MOSFET can ensure desired distribution of the two currents. Whenever the RTN current exceeds the current limit threshold, the GATE pin will pull low after a 365 μ s delay. The GATE pin is pulled low in thermal shutdown. After the controller cools down, and the inrush cycle is complete, the GATE pin rises again.

RTN: This pin provides the negative power return path for the load. Once V_{DD} exceeds the UVLO threshold, the internal pass MOSFET pulls RTN to VSS. Inrush limiting prevents the RTN current from exceeding about 140 mA until the bulk capacitance (C_{BULK} in [Figure 1](#)) is fully charged. Inrush ends when the RTN current drops below about 125 mA. The RTN current is subsequently limited to about 1 A. CDB pulls low to signal the downstream load that the bulk capacitance is fully charged. If RTN ever exceeds about 12 V for longer than 800 μ s, then the TPS2379 returns to inrush limiting.

T2P (Type-2 PSE Indicator): The controller pulls this pin to RTN whenever type-2 hardware classification has been observed. The T2P output will return to a high-impedance state if the part enters thermal shutdown, the pass MOSFET enters inrush limiting, or if a type-2 PSE was not detected. The circuitry that watches for type-2 hardware classification latches its result when the V_{DD} -to- V_{SS} voltage differential rises above the upper classification threshold. This circuit resets when the V_{DD} -to- V_{SS} voltage differential drops below the mark threshold. The T2P pin can be left unconnected if it is not used.

V_{DD} : This pin connects to the positive side of the input supply. It provides operating power to the PD controller and allows monitoring of the input line voltage.

V_{SS} : This is the input supply negative rail that serves as a local ground. The PowerPad™ must be connected to this pin to ensure proper operation.

PowerPAD

The PowerPad is internally connected to V_{SS} . It should be tied to a large V_{SS} copper area on the PCB to provide a low resistance thermal path to the circuit board. It is recommended that a clearance of 0.025" be maintained between V_{SS} and high-voltage signals such as V_{DD} .

TYPICAL CHARACTERISTICS

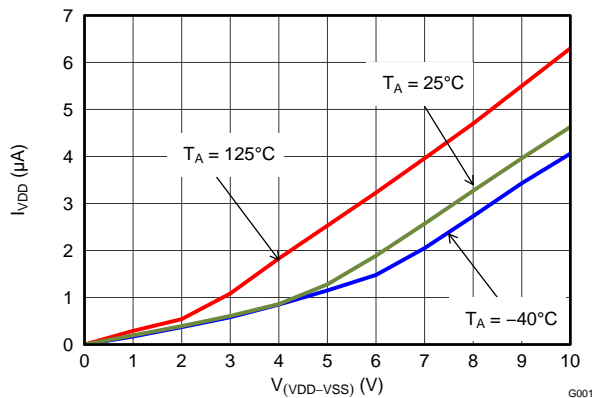

Figure 4. Detection Bias Current vs PoE Voltage

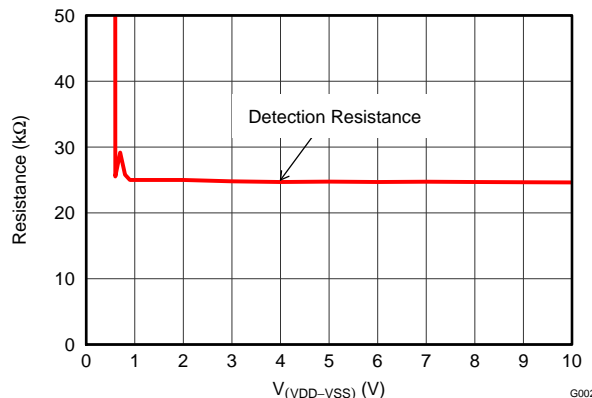

Figure 5. Detection Resistance vs PoE Voltage

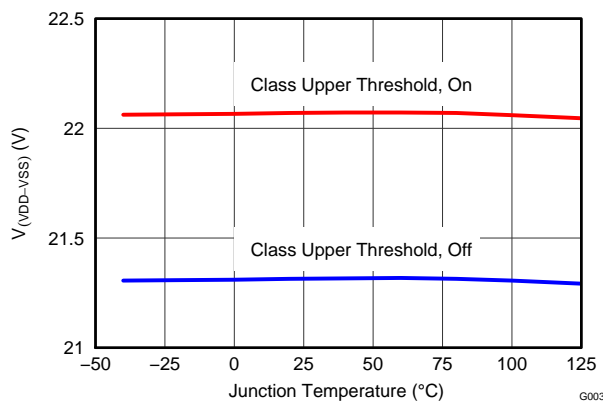

Figure 6. Classification Upper Threshold vs Temperature

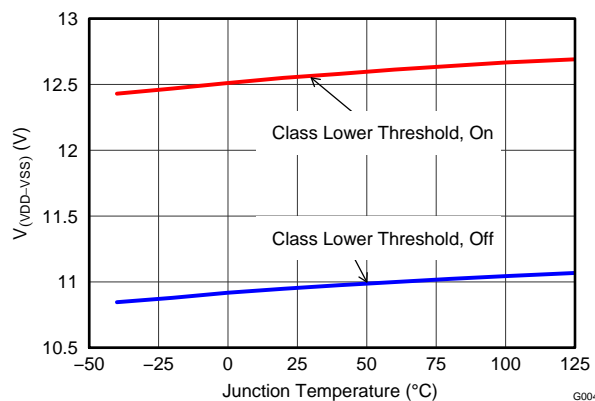

Figure 7. Classification Lower Threshold vs Temperature

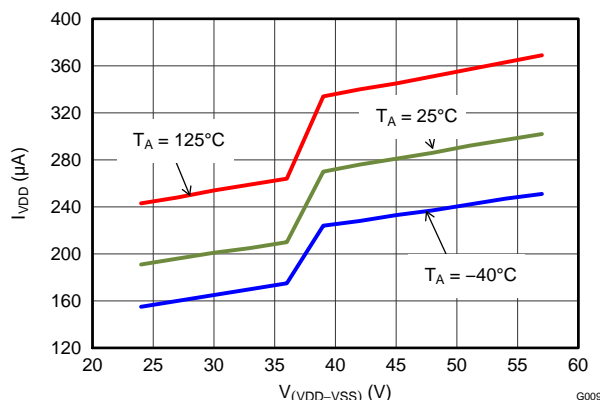

Figure 8. I_VDD Bias Current vs Voltage

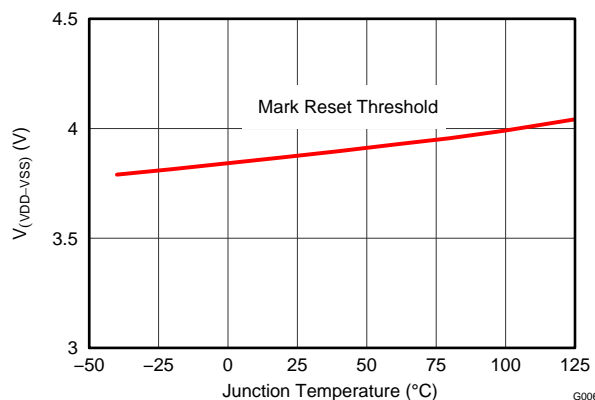

Figure 9. Mark Reset Threshold vs Temperature

TYPICAL CHARACTERISTICS (continued)

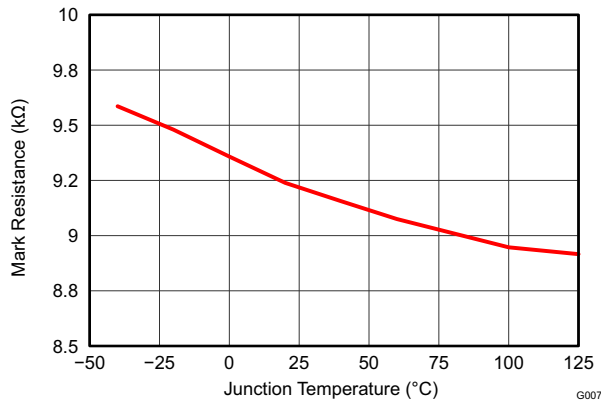

Figure 10. Mark Resistance vs Temperature

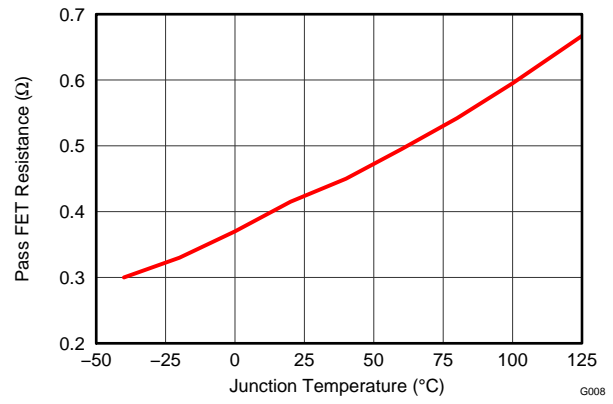

Figure 11. Pass FET Resistance vs Temperature

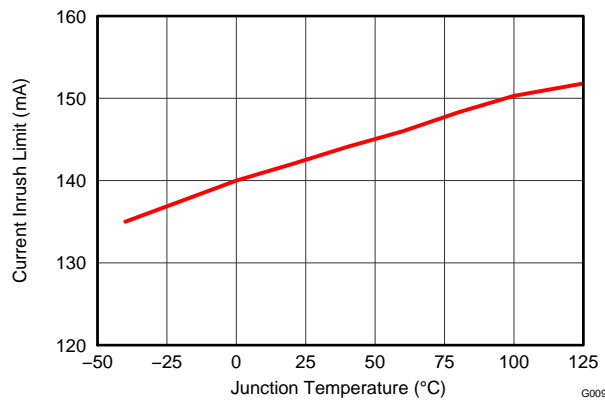

Figure 12. PoE Inrush Current Limit vs Temperature

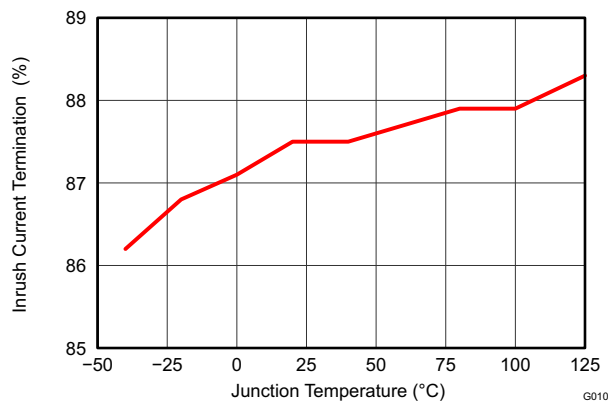

Figure 13. Inrush Termination Threshold vs Temperature

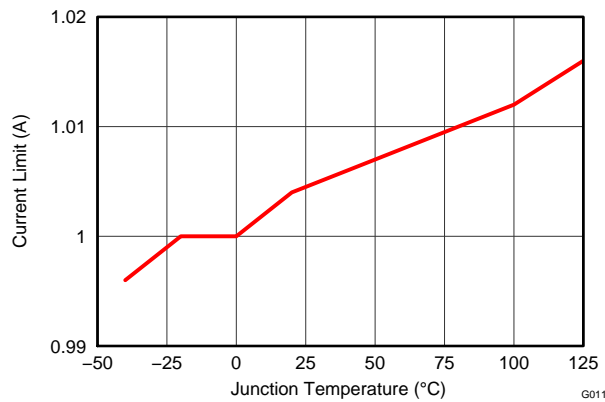

Figure 14. PoE Current Limit vs Temperature

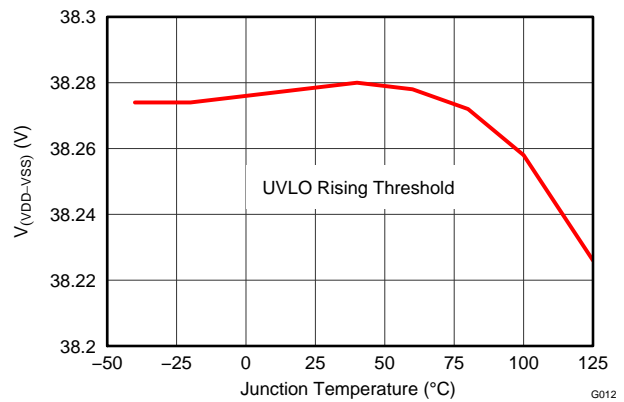

Figure 15. UVLO Rising Threshold vs Temperature

TYPICAL CHARACTERISTICS (continued)

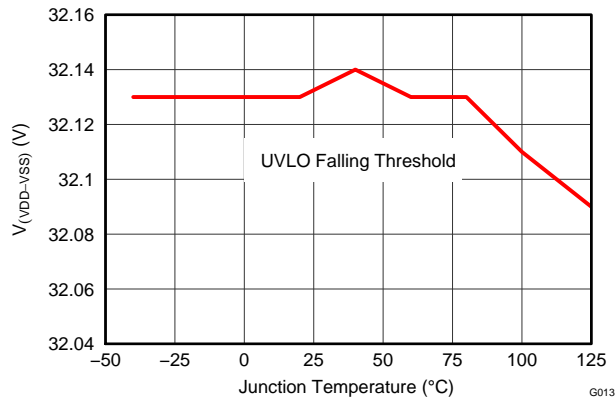

Figure 16. UVLO Falling Threshold vs Temperature

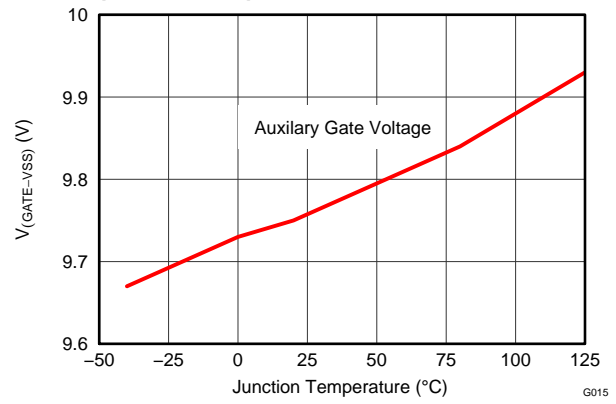

Figure 17. Auxiliary Gate Voltage vs Temperature

DETAILED DESCRIPTION

PoE OVERVIEW

The following text is intended as an aid in understanding the operation of the TPS2379 but not as a substitute for the IEEE 802.3at standard. The IEEE 802.3at standard is an update to IEEE 802.3-2008 clause 33 (PoE), adding high-power options and enhanced classification. Generally speaking, a device compliant to IEEE 802.3-2008 is referred to as a type 1 device, and devices with high power and enhanced classification will be referred to as type 2 devices. Standards change and should always be referenced when making design decisions.

The IEEE 802.3at standard defines a method of safely powering a PD (powered device) over a cable by power sourcing equipment (PSE), and then removing power if a PD is disconnected. The process proceeds through an idle state and three operational states of detection, classification, and operation. The PSE leaves the cable unpowered (idle state) while it periodically looks to see if something has been plugged in; this is referred to as detection. The low power levels used during detection are unlikely to damage devices not designed for PoE. If a valid PD signature is present, the PSE may inquire how much power the PD requires; this is referred to as classification. The PSE may then power the PD if it has adequate capacity.

Type 2 PSEs are required to do type 1 hardware classification plus a (new) data-layer classification, or an enhanced type 2 hardware classification. Type 1 PSEs are not required to do hardware or data link layer (DLL) classification. A type 2 PD must do type 2 hardware classification as well as DLL classification. The PD may return the default, 13W current-encoded class, or one of four other choices. DLL classification occurs after power-on and the Ethernet data link has been established.

Once started, the PD must present a maintain power signature (MPS) to assure the PSE that it is still present. The PSE monitors its output for a valid MPS, and turns the port off if it loses the MPS. Loss of the MPS returns the PSE to the idle state. [Figure 18](#) shows the operational states as a function of PD input voltage. The upper half is for IEEE 802.3-2008, and the lower half shows specific differences for IEEE 802.3at. The dashed lines in the lower half indicate these are the same (e.g., Detect and Class) for both.

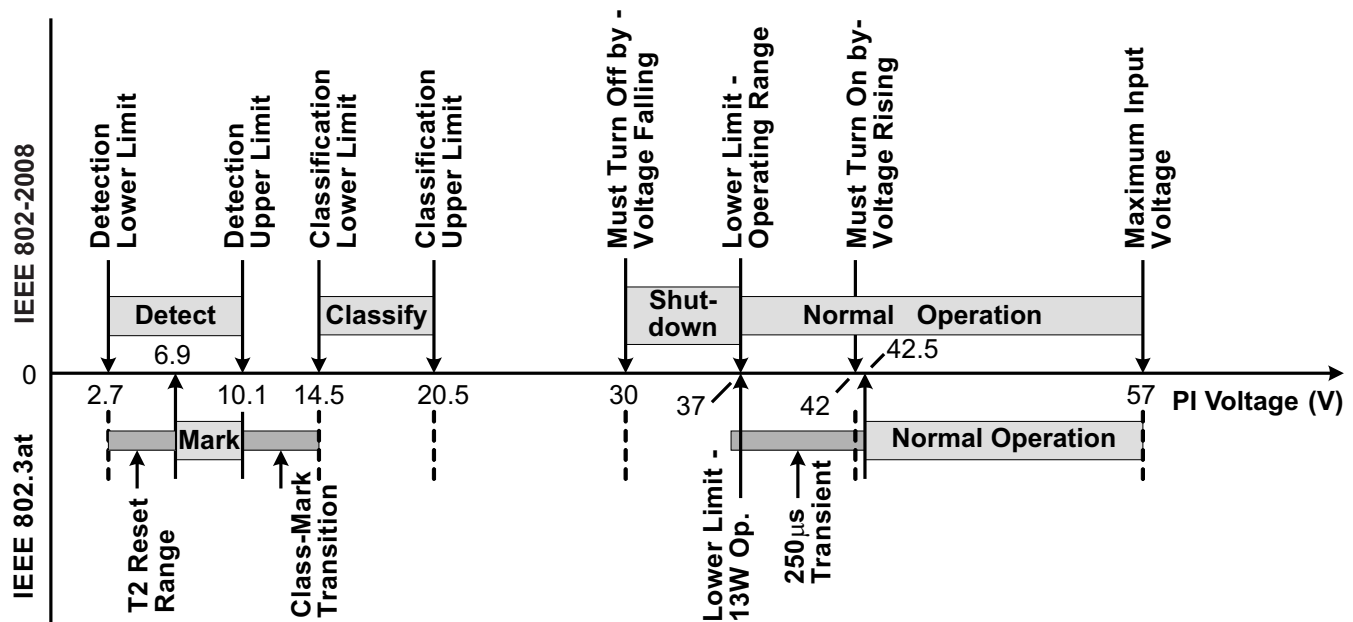

Figure 18. Threshold Voltages

The PD input, typically an RJ-45 eight-lead connector, is referred to as the power interface (PI). PD input requirements differ from PSE output requirements to account for voltage drops and operating margin. The standard allots the maximum loss to the cable regardless of the actual installation to simplify implementation. IEEE 802.3-2008 was designed to run over infrastructure including ISO/IEC 11801 class C (CAT3 per TIA/EIA-568) that may have had AWG 26 conductors. IEEE 802.3at type 2 cabling power loss allotments and voltage drops have been adjusted for 12.5 Ω power loops per ISO/IEC11801 class D (CAT5 or higher per TIA/EIA-568, typically AWG #24 conductors). [Table 2](#) shows key operational limits broken out for the two revisions of the standard.

Table 2. Comparison of Operational Limits

STANDARD	POWER LOOP RESISTANCE (max)	PSE OUTPUT POWER (min)	PSE STATIC OUTPUT VOLTAGE (min)	PD INPUT POWER (max)	STATIC PD INPUT VOLTAGE	
					Power \leq 12.95W	Power $>$ 12.95W
IEEE802.3at-2008 802.3at (Type 1)	20 Ω	15.4W	44V	12.95W	37V – 57V	N/A
802.3at (Type 2)	12.5 Ω	30W	50V	25.5W	37V – 57V	42.5V – 57V

The PSE can apply voltage either between the RX and TX pairs (pins 1 - 2 and 3 - 6 for 10baseT or 100baseT), or between the two spare pairs (4 - 5 and 7 - 8). Power application to the same pin combinations in 1000baseT systems is recognized in IEEE 802.3at. 1000baseT systems can handle data on all pairs, eliminating the spare pair terminology. The PSE may only apply voltage to one set of pairs at a time. The PD uses input diode bridges to accept power from any of the possible PSE configurations. The voltage drops associated with the input bridges create a difference between the standard limits at the PI and the TPS2379 specifications.

A compliant type 2 PD has power management requirements not present with a type 1 PD. These requirements include the following:

1. Must interpret type 2 hardware classification,
2. Must present hardware class 4,
3. Must implement DLL negotiation,
4. Must behave like a type 1 PD during inrush and startup,
5. Must not draw more than 13W for 80ms after the PSE applies operating voltage (power-up),
6. Must not draw more than 13W if it has not received a type 2 hardware classification or received permission through DLL,
7. Must meet various operating and transient templates, and
8. Optionally monitor for the presence or absence of an adapter (assume high power).

As a result of these requirements, the PD must be able to dynamically control its loading, and monitor T2P for changes. In cases where the design needs to know specifically if an adapter is plugged in and operational, the adapter should be individually monitored, typically with an optocoupler.

Threshold Voltages

The TPS2379 has a number of internal comparators with hysteresis for stable switching between the various states. [Figure 19](#) relates the parameters in the Electrical Characteristics section to the PoE states. The mode labeled Idle between Classification and Operation implies that the DEN, CLS, and RTN pins are all high impedance. The state labeled Mark, which is drawn in dashed lines, is part of the new type 2 hardware class state machine.

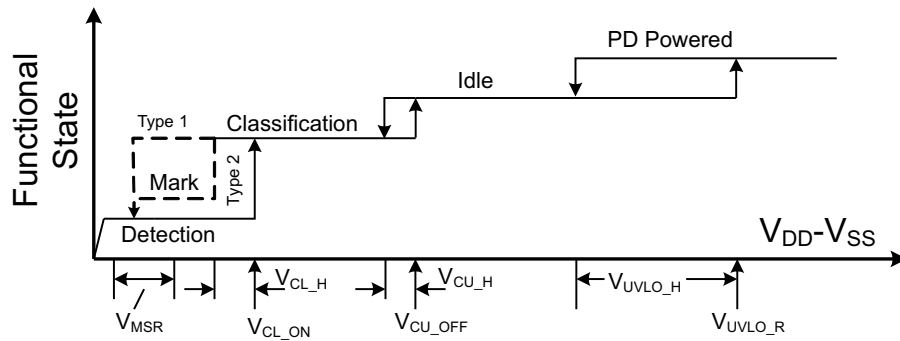

Note: Variable names refer to Electrical Characteristic Table parameters

Figure 19. Threshold Voltages

PoE Startup Sequence

The waveforms of Figure 20 demonstrate detection, classification, and startup from a PSE with type 2 hardware classification. The key waveforms shown are V(VDD-VSS), V(RTN-VSS), and IPI. IEEE 802.3at requires a minimum of two detection levels, two class and mark cycles, and startup from the second mark event. V_{RTN} to V_{SS} falls as the TPS2379 charges C_{BULK} following application of full voltage. In Figure 20, deassertion of the CDB signal is delayed and used to enable load current as seen in the I_{PI} waveform.

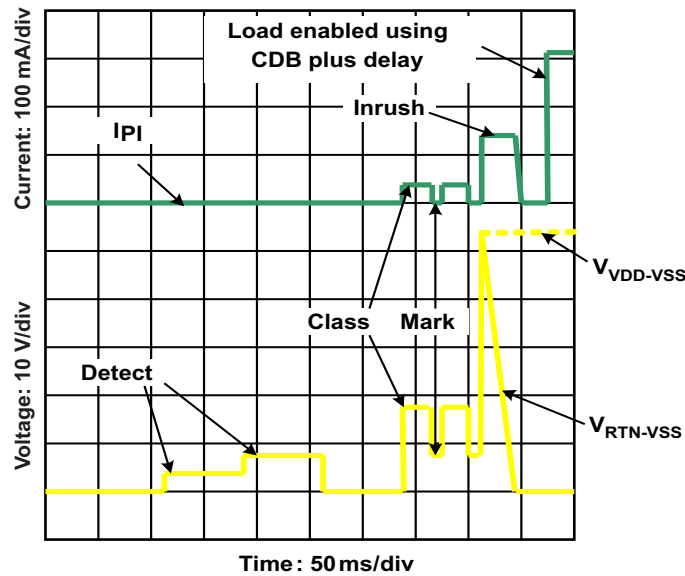

Figure 20. Startup

Detection

The TPS2379 pulls DEN to V_{SS} whenever $V_{(VDD-VSS)}$ is below the lower classification threshold. When the input voltage rises above V_{CL_ON} , the DEN pin goes to an open-drain condition to conserve power. While in detection, RTN is high impedance, and almost all the internal circuits are disabled. An R_{DEN} of 24.9 k Ω ($\pm 1\%$), presents the correct signature. It may be a small, low-power resistor since it only sees a stress of about 5 mW. A valid PD detection signature is an incremental resistance ($\Delta V/\Delta I$) between 23.75 k Ω and 26.25 k Ω at the PI.

The detection resistance seen by the PSE at the PI is the result of the input bridge resistance in series with the parallel combination of R_{DEN} and internal VDD loading. The input diode bridge’s incremental resistance may be hundreds of ohms at the very low currents drawn when 2.7 V is applied to the PI. The input bridge resistance is partially compensated by the TPS2379’s effective resistance during detection.

The type 2 hardware classification protocol of IEEE 802.3at specifies that a type 2 PSE drops its output voltage into the detection range during the classification sequence. The PD is required to have an incorrect detection signature in this condition, which is referred to as a mark event (see [Figure 20](#)). After the first mark event, the TPS2379 will present a signature less than 12 k Ω until it has experienced a $V_{(VDD-VSS)}$ voltage below the mark reset threshold (V_{MSR}). This is explained more fully under Hardware Classification.

Hardware Classification

Hardware classification allows a PSE to determine a PD's power requirements before powering, and helps with power management once power is applied. Type 2 hardware classification permits high power PSEs and PDs to determine whether the connected device can support high-power operation. A type 2 PD presents class 4 in hardware to indicate that it is a high-power device. A type 1 PSE will treat a class 4 device like a class 0 device, allotting 13 W if it chooses to power the PD. A PD that receives a 2-event class understands that it is powered from a high-power PSE and it may draw up to 25.5 W immediately after the 80 ms startup period completes. A type 2 PD that does not receive a 2-event hardware classification may choose to not start, or must start in a 13 W condition and request more power through the DLL after startup. The standard requires a type 2 PD to indicate that it is underpowered if this occurs. Startup of a high-power PD under 13 W implicitly requires some form of powering down sections of the application circuits.

The maximum power entries in [Table 1](#) determine the class the PD must advertise. The PSE may disconnect a PD if it draws more than its stated Class power, which may be the hardware class or a lower DLL-derived power level. The standard permits the PD to draw limited current peaks that increase the instantaneous power above the [Table 1](#) limit, however the average power requirement always applies.

The TPS2379 implements two-event classification. Selecting an RCLS of 63.4 Ω provides a valid type 2 signature. TPS2379 may be used as a compatible type 1 device simply by programming class 0–3 per [Table 1](#). DLL communication is implemented by the Ethernet communication system in the PD and is not implemented by the TPS2379.

The TPS2379 disables classification above V_{CU_OFF} to avoid excessive power dissipation. CLS voltage is turned off during PD thermal limiting or when DEN is active. The CLS output is inherently current limited, but should not be shorted to V_{SS} for long periods of time.

[Figure 21](#) shows how classification works for the TPS2379. Transition from state-to-state occurs when comparator thresholds are crossed (see [Figure 18](#) and [Figure 19](#)). These comparators have hysteresis, which adds inherent memory to the machine. Operation begins at idle (unpowered by PSE) and proceeds with increasing voltage from left to right. A 2-event classification follows the (heavy lined) path towards the bottom, ending up with a latched type 2 decode along the lower branch that is highlighted. This state results in a low T2P during normal operation. Once the valid path to type 2 PSE detection is broken, the input voltage must transition below the mark reset threshold to start anew.

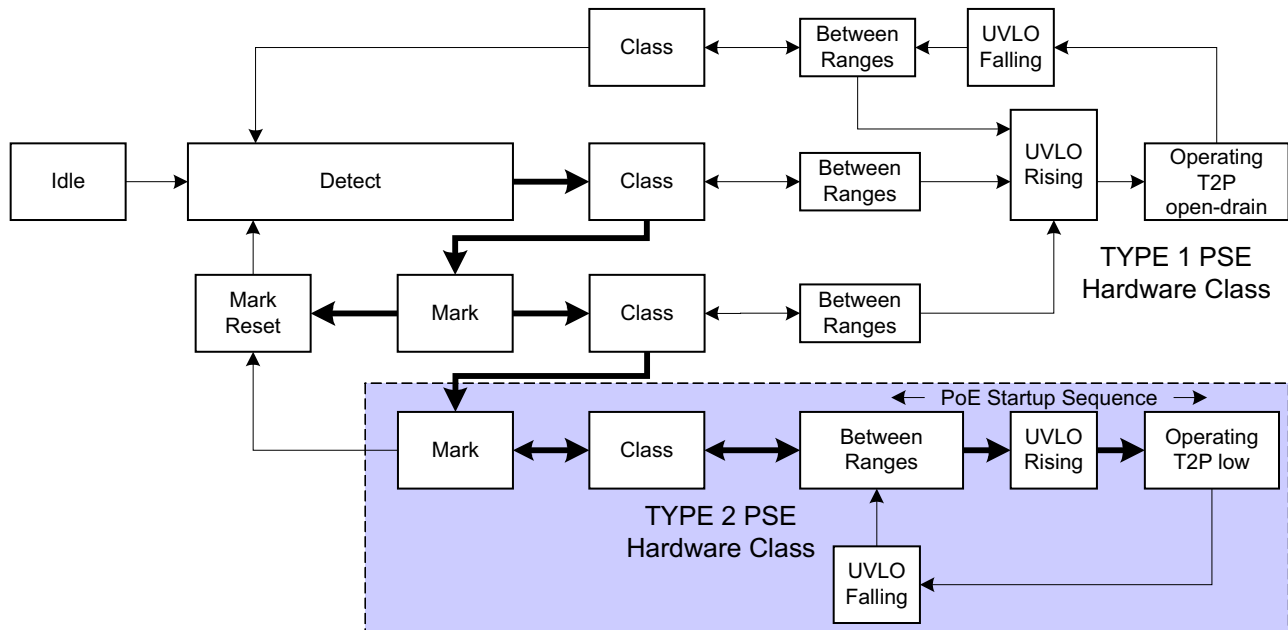

Figure 21. Two-Event Class Internal States

Inrush and Startup

IEEE 802.3at has a startup current and time limitation, providing type 2 PSE compatibility for type 1 PDs. A type 2 PSE limits output current to between 400 mA and 450 mA for up to 75 ms after power-up (applying “48 V” to the PI) in order to mirror type 1 PSE functionality. The type 2 PSE will support higher output current after 75 ms. The TPS2379 implements a 140 mA inrush current, which is compatible with all PSE types. A high-power PD must limit its converter startup peak current. The operational current cannot exceed 400 mA for a period of 80 ms or longer. This requirement implicitly requires some form of powering down sections of the application circuits.

Maintain Power Signature

The MPS is an electrical signature presented by the PD to assure the PSE that it is still present after operating voltage is applied. A valid MPS consists of a minimum dc current of 10 mA (or a 10 mA pulsed current for at least 75 ms every 325 ms) and an ac impedance lower than 26.3 kΩ in parallel with 0.05 μF. The ac impedance is usually accomplished by the minimum operating C_{BULK} requirement of 5 μF. When DEN is used to force the hotswap switch off, the dc MPS will not be met. A PSE that monitors the dc MPS will remove power from the PD when this occurs. A PSE that monitors only the ac MPS may remove power from the PD.

Startup and Operation

The internal PoE UVLO (Under Voltage Lock Out) circuit holds the hotswap switch off before the PSE provides full voltage to the PD. This prevents the downstream converter circuits from loading the PoE input during detection and classification. The converter circuits will discharge C_{BULK} while the PD is unpowered. Thus $V_{(VDD-RTN)}$ will be a small voltage just after full voltage is applied to the PD, as seen in Figure 20. The PSE drives the PI voltage to the operating range once it has decided to power up the PD. When V_{VDD} rises above the UVLO turn-on threshold (V_{UVLO-R} , ~38 V) with RTN high, the TPS2379 enables the hotswap MOSFET with a ~140 mA (inrush) current limit as seen in Figure 22. The CDB pin is active while C_{BULK} charges and V_{RTN} falls from V_{VDD} to nearly V_{VSS} . Once the inrush current falls about 10% below the inrush current limit, the PD current limit switches to the operational level (~1000 mA) and CDB is deasserted to allow downstream converter circuitry to start. The TPS2379 asserts GATE after inrush is complete to enable an external pass MOSFET if used. In Figure 22, T2P is active because a type 2 PSE is plugged in.

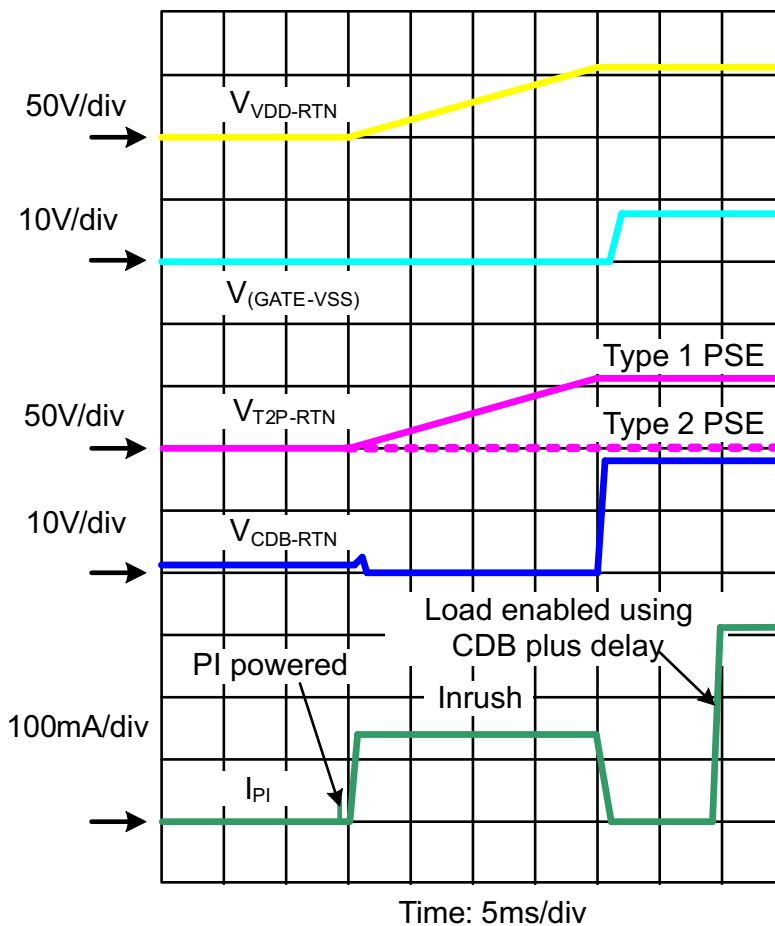

Figure 22. Power Up and Start

PD Hotswap Operation

IEEE 802.3at has taken a new approach to PSE output limiting. A type 2 PSE must meet an output current versus time template with specified minimum and maximum sourcing boundaries. The peak output current may be as high as 50 A for 10 μ s or 1.75 A for 75 ms. This makes robust protection of the PD device even more important than it was in IEEE 802.3-2008.

The internal hotswap MOSFET is protected against output faults and input voltage steps with a current limit and deglitched (time-delay filtered) foldback. An overload on the pass MOSFET engages the current limit, with $V_{RTN} - V_{VSS}$ rising as a result. GATE is pulled down about 300 μ s after RTN current reaches the current limit level. If V_{RTN} rises above ~12 V for longer than ~800 μ s, the current limit reverts to the inrush value. The 800 μ s deglitch feature prevents momentary transients from causing a PD reset, provided that recovery lies within the bounds of the hotswap and PSE protection. Figure 23 shows an example of the RTN current profile during VDD to RTN short circuit when only the internal hotswap MOSFET is used. The hotswap MOSFET goes into current limit, causing the RTN voltage to increase. Once V_{RTN} exceeds 12V, I_{RTN} which was clamped to the current limit drops to the level of inrush current limit after 800 μ s.

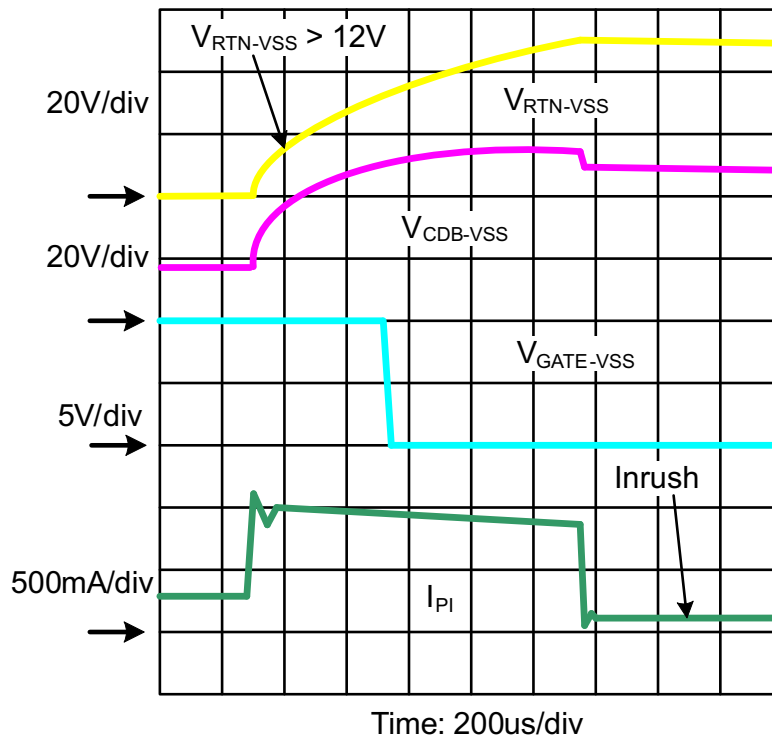

Figure 23. Response to PD Output Short Circuit Without AUX MOSFET

Figure 24 shows an example of the RTN current profile during VDD to RTN short circuit when the external MOSFET is used. The circuit is depicted in Figure 1. The current will divide between the internal and external MOSFETs. During the short circuit, the hotswap MOSFET goes into current limit, causing the RTN voltage to increase. When the internal MOSFET exceeds current limit for $\sim 300\mu s$, GATE will de-assert and shut off the auxiliary MOSFET. V_{RTN} will rise quickly and the internal MOSFET will go into current limit for $\sim 800\mu s$ (after $V_{RTN} > \sim 12V$) and then I_{RTN} which was clamped to the current limit drops into the inrush current limit.

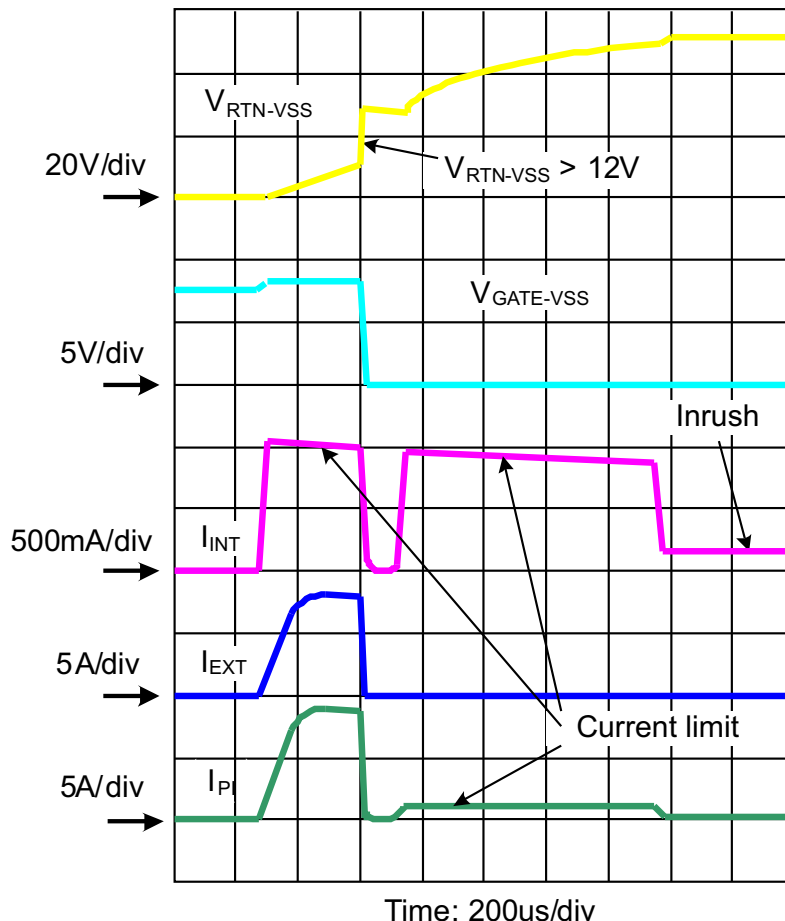

Figure 24. Response to PD Output Short Circuit with AUX MOSFET

The PD control has a thermal sensor that protects the internal hotswap MOSFET. Conditions like startup or operation into a V_{DD} -to-RTN short cause high power dissipation in the MOSFET. An over-temperature shutdown (OTSD) turns off the hotswap MOSFET and class regulator, which are restarted after the device cools. The hotswap MOSFET will be re-enabled with the inrush current limit when exiting from an over-temperature event. Pulling DEN to V_{SS} during powered operation causes the internal hotswap MOSFET to turn off.

The hotswap switch will be forced off under the following conditions:

1. $V_{(DEN - VSS)} < V_{PD_DIS}$ when $V_{VDD} - V_{VSS}$ is in the operational range,
2. PD is over-temperature, or
3. $V_{(DEN - VSS)}$ PoE UVLO falling threshold (~32 V).

CDB and T2P

CDB (converter disable) is an active-low pin that indicates when the internal hotswap MOSFET is inrush limiting. CDB de-asserts when inrush is over and can be used to enable a downstream converter to start up. Common interfaces to the converter controller include the soft start or enable pins.

T2P (type 2 PSE) is an active-low multifunction pin that indicates if (PSE = Type_2) and (PD current limit \neq Inrush).

The usage of T2P is demonstrated in Figure 27. When PSE applies and PD observes a type 2 hardware classification, T2P pin is pulled to RTN as a indication of the type of PSE.

Auxiliary Pass MOSFET Control

The TPS2379 can be used in non-standard applications requiring power significantly above the IEEE802.3at, type 2 levels. This implementation can be achieved by utilizing all four Ethernet wire pairs and boosting the TPS2379 hotswap MOSFET operating current limit. Boosting the TPS2379 operating current limit is achieved by adding an external pass MOSFET to share the total load current with the internal hotswap MOSFET. The external pass MOSFET is enabled by the GATE pin after the internal hotswap MOSFET inrush is complete. The GATE pin will de-assert if the TPS2379 internal current limit is exceeded in excess of 300 μ s.

A comprehensive high power POE design example is discussed in application report *Implementing a 60-W, End-to-End PoE System* (literature number [SLVA498](#)).

Using DEN to Disable PoE

The DEN pin may be used to turn the PoE hotswap switch off by pulling it to VSS while in the operational state, or to prevent detection when in the idle state. A low voltage on DEN forces the hotswap MOSFET off during normal operation.

APPLICATION INFORMATION

INPUT BRIDGES AND SCHOTTKY DIODES

Using Schottky diodes instead of PN junction diodes for the PoE input bridges will reduce the power dissipation in these devices by about 30%. There are, however, some things to consider when using them.

The IEEE standard specifies a maximum backfeed voltage of 2.8 V. A 100 k Ω resistor is placed between the unpowered pairs and the voltage is measured across the resistor. Schottky diodes often have a higher reverse leakage current than PN diodes, making this a harder requirement to meet. To compensate, use conservative design for diode operating temperature, select lower-leakage devices where possible, and match leakage and temperatures by using packaged bridges.

Schottky diode leakage currents and lower dynamic resistances can impact the detection signature. Setting reasonable expectations for the temperature range over which the detection signature is accurate is the simplest solution. Increasing R_{DEN} slightly may also help meet the requirement.

Schottky diodes have proven less robust to the stresses of ESD transients than PN junction diodes. After exposure to ESD, Schottky diodes may become shorted or leak. Care must be taken to provide adequate protection in line with the exposure levels. This protection may be as simple as ferrite beads and capacitors.

As a general recommendation, use 1 A or 2 A, 100 V rated discrete or bridge diodes for the input rectifiers.

Protection, D1

A TVS, D1, across the rectified PoE voltage per [Figure 1](#) must be used. A SMAJ58A, or equivalent, is recommended for general indoor applications. Adequate capacitive filtering or a TVS must limit input transient voltage to within the absolute maximum ratings. Outdoor transient levels or special applications require additional protection.

Capacitor, C₁

The IEEE 802.3at standard specifies an input bypass capacitor (from VDD to VSS) of 0.05 μ F to 0.12 μ F. Typically a 0.1 μ F, 100 V, 10% ceramic capacitor is used.

Detection Resistor, R_{DEN}

The IEEE 802.3at standard specifies a detection signature resistance, R_{DEN} between 23.75 k Ω and 26.25 k Ω , or 25 k Ω \pm 5%. A resistor of 24.9 k Ω \pm 1% is recommended for R_{DEN}.

Classification Resistor, R_{CLS}

Connect a resistor from CLS to VSS to program the classification current according to the IEEE 802.3at standard. The class power assigned should correspond to the maximum average power drawn by the PD during operation. Select R_{CLS} according to [Table 1](#). For a high power design, choose class 4 and R_{CLS} = 63.4 Ω .

CDB Pin Interface

The CDB pin can be used to inhibit downstream converter start up by keeping the soft start pin low. [Figure 25](#) shows an example where CDB connects to the SS pin of a UCC3809 DC/DC controller. Since CDB is an open-drain output, it will not affect the soft start capacitor charge time when it de-asserts. Another common use of the CDB pin is to enable a converter with an active-high enable input. In this case, CDB may require a pullup resistor to either VDD, or to a bias supply, depending on the requirements of the controller enable pin.

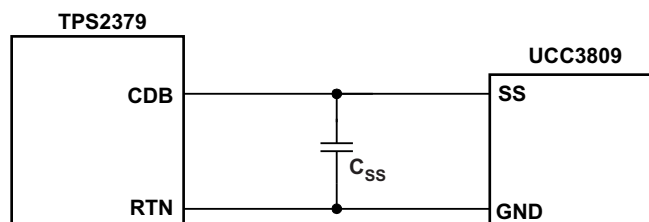

Figure 25. CDB Interface

GATE Pin Interface

A non-standard PoE system can be designed to meet extended power requirements and retain the PoE benefits such as protection of non – PoE devices and fault tolerance. Such a solution will not comply with IEEE802.3at and should be designed and operated as stand-alone system. The TPS2379 GATE pin is used to control an external pass MOSFET as shown in [Figure 26](#). When inrush is complete, GATE sources 38µA to enable Q1, the external pass MOSFET. When Q1 is fully enhanced, CDB de-asserts and enables the load. Delaying the de-assertion of CDB until Q1 becomes fully enhanced prevents nuisance over-current faults that could occur with heavy startup loads. A resistor from GATE to VSS is not required to ensure that Q1 turns off; but, if a resistor from GATE to VSS is used, choose a value large enough so that the GATE sourcing current can fully enhance Q1.

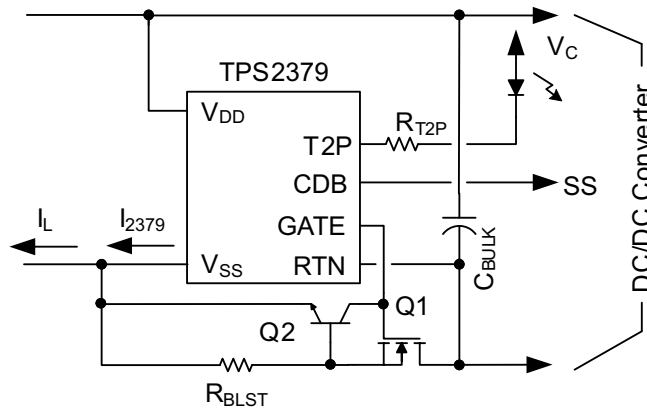

Figure 26. GATE Interface

EXTERNAL BOOST CIRCUIT (Q1, Q2, and R_{BLST}) CONSIDERATIONS

As discussed above, the IEEE802.3at template bounds the peak PSE output current between 50A for 10 µs and 1.75 A for 75 ms for a two-pair system. In a non-standard, four-pair system these current levels can be assumed to double. During an overload event, the TPS2379 will limit current to ~1A and the rest of the current will flow through Q1 and R_{BLST}. Ignoring the ballast resistor and parasitic impedances the current through Q1 could be as high as 99A.

Actual system level behavior will be influenced by the circuit parasitic impedances, diode bridge impedance, contact resistances, external MOSFET resistance, and input voltage droop during the overload event. The impedances act to reduce the peak current as well as drop the voltage across Q1 during the overload event. The designer must evaluate the overload performance of their system and ensure that the selected external MOSFET safe operating area (SOA) is not violated during the output overload. The duration of the overload can be terminated if the input voltage droop to the TPS2379 goes below the UVLO falling threshold (32V typical). When UVLO occurs, the internal MOSFET is disabled, GATE goes low, and the external MOSFET is disabled. This shortened overload duration is beneficial when evaluating the external MOSFET SOA performance.

Additional limiting and control of the external output overload current can be achieved by using the ballast resistor, R_{BLST}. R_{BLST} is used to help balance the internal and external MOSFET load currents, and to implement external current limiting through the use of Q2. The load current, I_L divides between the external Q1 and the internal pass MOSFET of the TPS2379 as shown in [Equation 1](#).

$$I_{2379} = I_L \times \frac{R_{BLST} + R_{Q1}}{R_{BLST} + R_{Q1} + R_{2379}} \quad (1)$$

R_{Q1} is the ON resistance of Q1 and R₂₃₇₉ is the ON resistance of the TPS2379. Q2 can be used to force Q1 to limit its current when the voltage across R_{BLST} exceeds V_{BEON} of Q2. Further discussion of these details, as well as additional considerations involving PD classification, are discussed in the application report *Implementing a 60 W end-to-end PoE system* (literature number [SLVA498](#)).

T2P Pin Interface

The T2P pin is an active-low, open-drain output which indicates that a high power source is available. An optocoupler can interface the T2P pin to circuitry on the secondary side of the converter. A high-gain optocoupler and a high-impedance (e.g., CMOS) receiver are recommended. Design of the T2P optocoupler interface can be accomplished as follows:

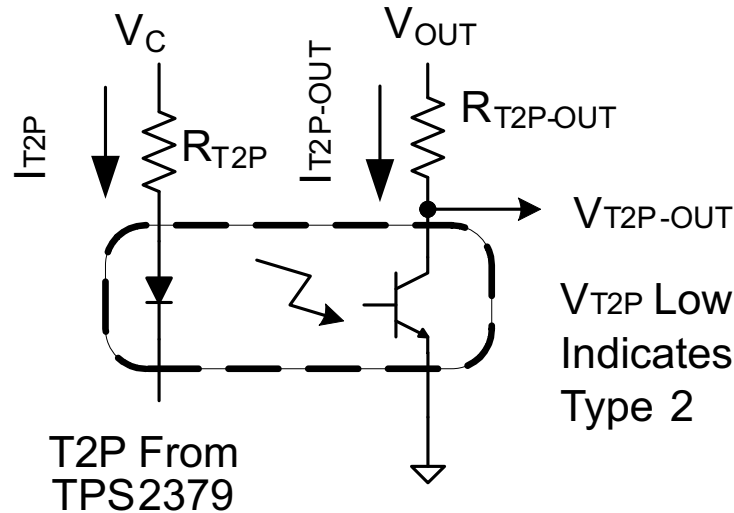

Figure 27. T2P Interface

- As shown in Figure 27, let $V_C = 12\text{ V}$, $V_{OUT} = 5\text{ V}$, $R_{T2P-OUT} = 10\text{ k}\Omega$, $V_{T2P} = 260\text{ mV}$, $V_{T2P-OUT} = 400\text{ mV}$.

$$I_{T2P-OUT} = \frac{V_{OUT} - V_{T2P-OUT}}{R_{T2P-OUT}} = \frac{5 - 0.4}{10000} = 0.46\text{mA} \quad (2)$$

- The optocoupler current transfer ratio, CTR, will be needed to determine R_{T2P} . A device with a minimum CTR of 100% at 1 mA LED bias current, I_{T2P} , is selected. Note that in practice, CTR will vary with temperature, LED bias current and aging. These variations may require some iteration using the CTR-versus- I_{DIODE} curve on the optocoupler data sheet.
 - The approximate forward voltage of the optocoupler diode, V_{FWLED} , is 1.1 V from the data sheet.
 -

$$I_{T2P-MIN} = \frac{I_{T2P-OUT}}{CTR} = \frac{0.46\text{mA}}{1.00} = 0.46\text{mA}, \text{ Select } I_{T2P} = 1\text{mA}$$

$$R_{T2P} = \frac{V_C - V_{T2P} - V_{FWLED}}{I_{T2P}} = \frac{12\text{ V} - 0.26\text{ V} - 1.1\text{ V}}{1\text{mA}} = 10.6\text{k}\Omega$$

- Select a 10.7 k Ω resistor.

THERMAL CONSIDERATIONS AND OTSD

Sources of nearby local PCB heating should be considered during the thermal design. Typical calculations assume that the TPS2379 is the only heat source contributing to the PCB temperature rise. It is possible for a normally operating TPS2379 device to experience an OTSD event if it is excessively heated by a nearby device.

ESD

ESD requirements for a unit that incorporates the TPS2379 have a much broader scope and operational implications than are used in TI's testing. Unit-level requirements should not be confused with reference design testing that only validates the ruggedness of the TPS2379.

TPS2379

SLVSB98 –MARCH 2012

www.ti.com

LAYOUT

Printed circuit board layout recommendations are provided in the evaluation module (EVM) documentation available for this device.

DDA (R-PDSO-G8)

PowerPAD™ PLASTIC SMALL-OUTLINE



4202561/F 12/11

- NOTES:
- A. All linear dimensions are in millimeters. Dimensioning and tolerancing per ASME Y14.5-1994.
 - B. This drawing is subject to change without notice.
 - C. Body dimensions do not include mold flash or protrusion not to exceed 0,15.
 - D. This package is designed to be soldered to a thermal pad on the board. Refer to Technical Brief, PowerPad Thermally Enhanced Package, Texas Instruments Literature No. SLMA002 for information regarding recommended board layout. This document is available at www.ti.com <<http://www.ti.com>>.
 - E. See the additional figure in the Product Data Sheet for details regarding the exposed thermal pad features and dimensions.
 - F. This package complies to JEDEC MS-012 variation BA

PowerPAD is a trademark of Texas Instruments.

DDA (R-PDSO-G8)

PowerPAD™ PLASTIC SMALL OUTLINE

THERMAL INFORMATION

This PowerPAD™ package incorporates an exposed thermal pad that is designed to be attached to a printed circuit board (PCB). The thermal pad must be soldered directly to the PCB. After soldering, the PCB can be used as a heatsink. In addition, through the use of thermal vias, the thermal pad can be attached directly to the appropriate copper plane shown in the electrical schematic for the device, or alternatively, can be attached to a special heatsink structure designed into the PCB. This design optimizes the heat transfer from the integrated circuit (IC).

For additional information on the PowerPAD package and how to take advantage of its heat dissipating abilities, refer to Technical Brief, PowerPAD Thermally Enhanced Package, Texas Instruments Literature No. SLMA002 and Application Brief, PowerPAD Made Easy, Texas Instruments Literature No. SLMA004. Both documents are available at www.ti.com.

The exposed thermal pad dimensions for this package are shown in the following illustration.

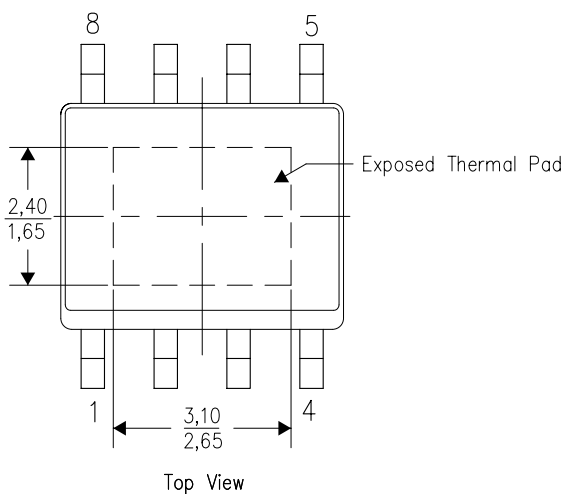

Exposed Thermal Pad Dimensions

4206322-6/K 12/11

NOTE: A. All linear dimensions are in millimeters

PowerPAD is a trademark of Texas Instruments

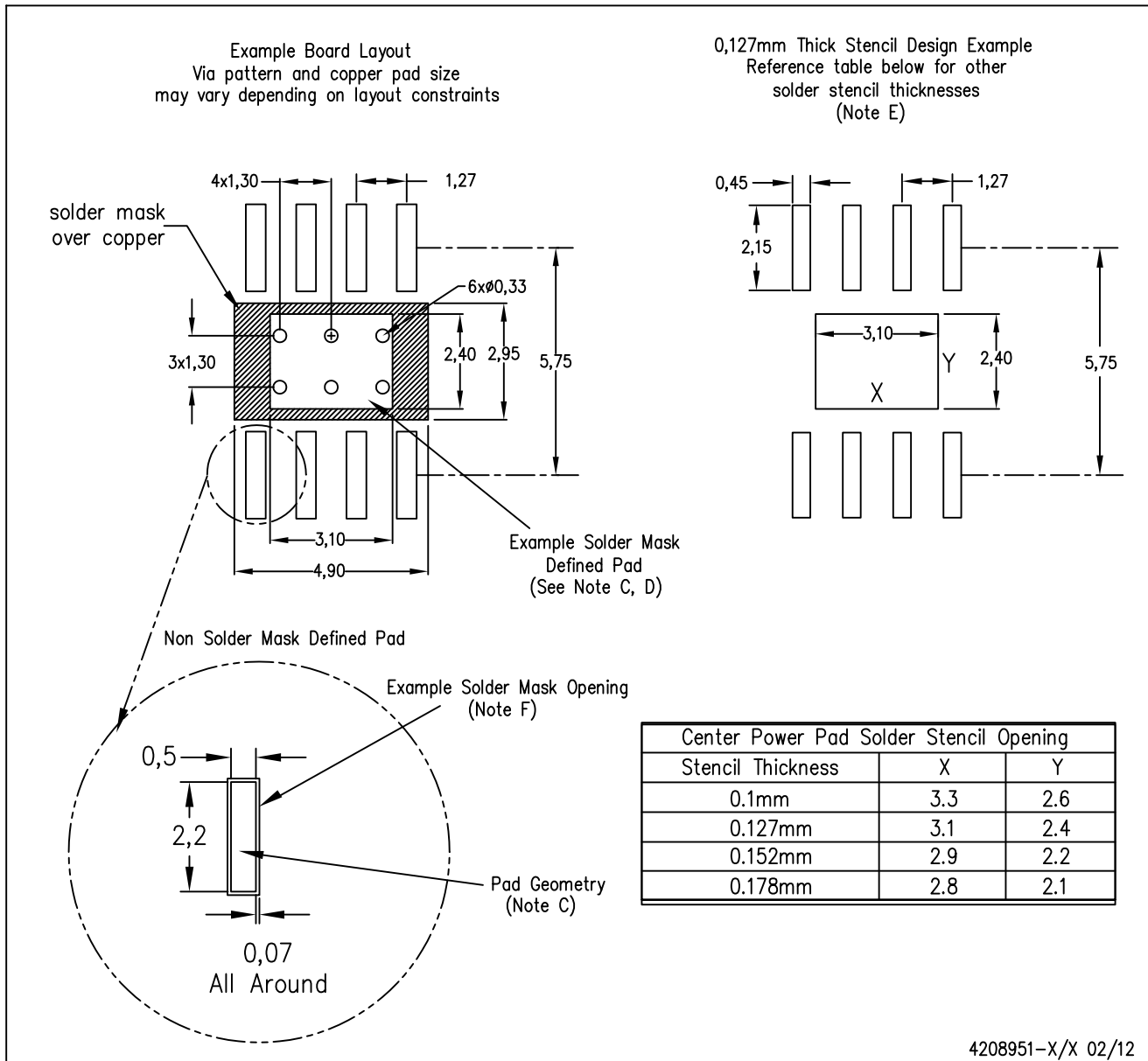

- NOTES:
- A. All linear dimensions are in millimeters.
 - B. This drawing is subject to change without notice.
 - C. Publication IPC-7351 is recommended for alternate designs.
 - D. This package is designed to be soldered to a thermal pad on the board. Refer to Technical Brief, PowerPad Thermally Enhanced Package, Texas Instruments Literature No. SLMA002, SLMA004, and also the Product Data Sheets for specific thermal information, via requirements, and recommended board layout. These documents are available at www.ti.com <<http://www.ti.com>>. Publication IPC-7351 is recommended for alternate designs.
 - E. Laser cutting apertures with trapezoidal walls and also rounding corners will offer better paste release. Customers should contact their board assembly site for stencil design recommendations. Example stencil design based on a 50% volumetric metal load solder paste. Refer to IPC-7525 for other stencil recommendations.
 - F. Customers should contact their board fabrication site for solder mask tolerances between and around signal pads.

PowerPAD is a trademark of Texas Instruments.

PACKAGING INFORMATION

Orderable Device	Status ⁽¹⁾	Package Type	Package Drawing	Pins	Package Qty	Eco Plan ⁽²⁾	Lead/ Ball Finish	MSL Peak Temp ⁽³⁾	Samples (Requires Login)
TPS2379DDA	ACTIVE	SO PowerPAD	DDA	8	75	Green (RoHS & no Sb/Br)	CU NIPDAUAG	Level-2-260C-1 YEAR	
TPS2379DDAR	ACTIVE	SO PowerPAD	DDA	8	2500	Green (RoHS & no Sb/Br)	CU NIPDAUAG	Level-2-260C-1 YEAR	

⁽¹⁾ The marketing status values are defined as follows:

ACTIVE: Product device recommended for new designs.

LIFEBUY: TI has announced that the device will be discontinued, and a lifetime-buy period is in effect.

NRND: Not recommended for new designs. Device is in production to support existing customers, but TI does not recommend using this part in a new design.

PREVIEW: Device has been announced but is not in production. Samples may or may not be available.

OBsolete: TI has discontinued the production of the device.

⁽²⁾ Eco Plan - The planned eco-friendly classification: Pb-Free (RoHS), Pb-Free (RoHS Exempt), or Green (RoHS & no Sb/Br) - please check <http://www.ti.com/productcontent> for the latest availability information and additional product content details.

TBD: The Pb-Free/Green conversion plan has not been defined.

Pb-Free (RoHS): TI's terms "Lead-Free" or "Pb-Free" mean semiconductor products that are compatible with the current RoHS requirements for all 6 substances, including the requirement that lead not exceed 0.1% by weight in homogeneous materials. Where designed to be soldered at high temperatures, TI Pb-Free products are suitable for use in specified lead-free processes.

Pb-Free (RoHS Exempt): This component has a RoHS exemption for either 1) lead-based flip-chip solder bumps used between the die and package, or 2) lead-based die adhesive used between the die and leadframe. The component is otherwise considered Pb-Free (RoHS compatible) as defined above.

Green (RoHS & no Sb/Br): TI defines "Green" to mean Pb-Free (RoHS compatible), and free of Bromine (Br) and Antimony (Sb) based flame retardants (Br or Sb do not exceed 0.1% by weight in homogeneous material)

⁽³⁾ MSL, Peak Temp. -- The Moisture Sensitivity Level rating according to the JEDEC industry standard classifications, and peak solder temperature.

Important Information and Disclaimer: The information provided on this page represents TI's knowledge and belief as of the date that it is provided. TI bases its knowledge and belief on information provided by third parties, and makes no representation or warranty as to the accuracy of such information. Efforts are underway to better integrate information from third parties. TI has taken and continues to take reasonable steps to provide representative and accurate information but may not have conducted destructive testing or chemical analysis on incoming materials and chemicals. TI and TI suppliers consider certain information to be proprietary, and thus CAS numbers and other limited information may not be available for release.

In no event shall TI's liability arising out of such information exceed the total purchase price of the TI part(s) at issue in this document sold by TI to Customer on an annual basis.

DDA (R-PDSO-G8)

PowerPAD™ PLASTIC SMALL-OUTLINE

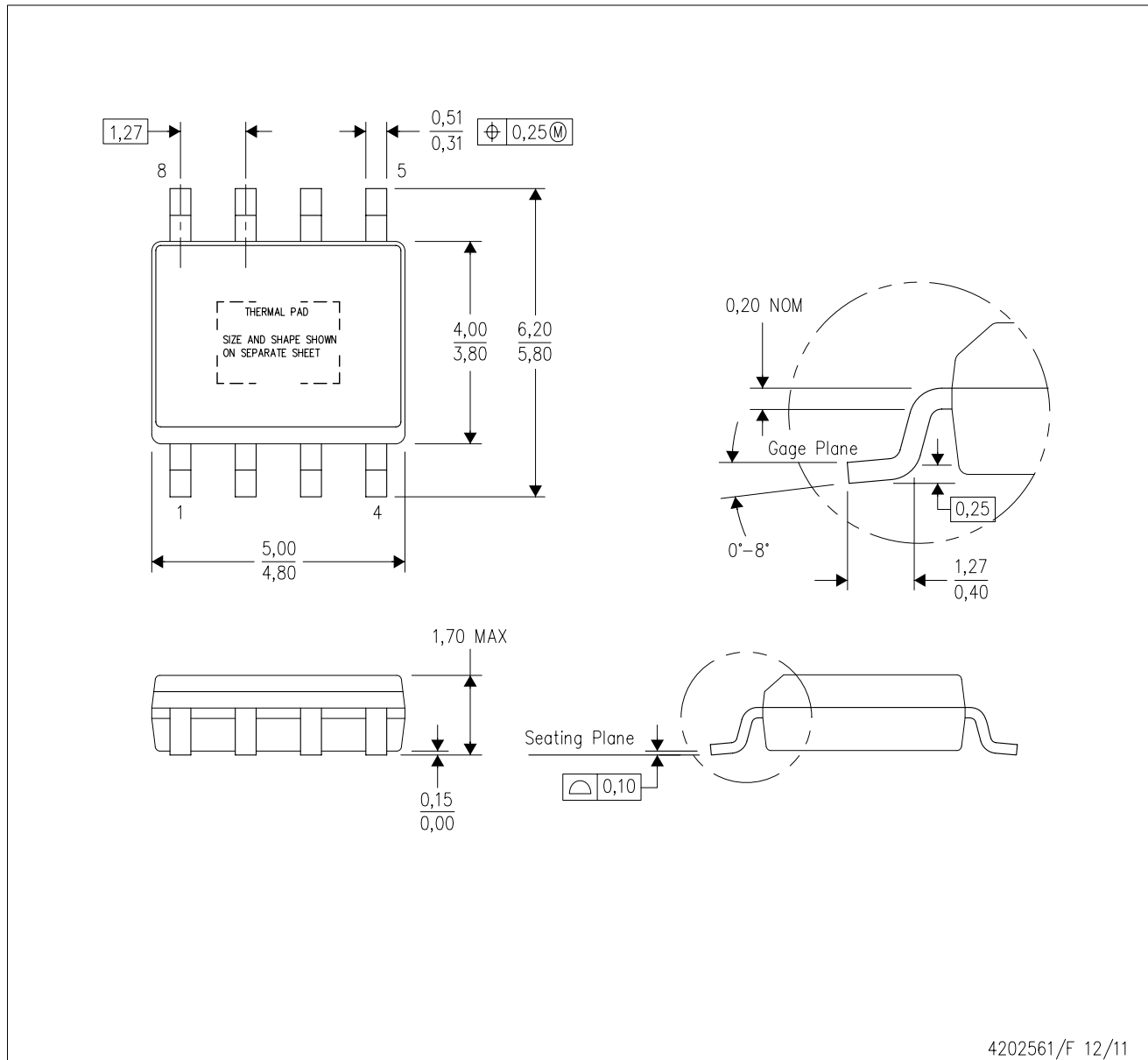

- NOTES:
- All linear dimensions are in millimeters. Dimensioning and tolerancing per ASME Y14.5-1994.
 - This drawing is subject to change without notice.
 - Body dimensions do not include mold flash or protrusion not to exceed 0,15.
 - This package is designed to be soldered to a thermal pad on the board. Refer to Technical Brief, PowerPad Thermally Enhanced Package, Texas Instruments Literature No. SLMA002 for information regarding recommended board layout. This document is available at www.ti.com <<http://www.ti.com>>.
 - See the additional figure in the Product Data Sheet for details regarding the exposed thermal pad features and dimensions.
 - This package complies to JEDEC MS-012 variation BA

PowerPAD is a trademark of Texas Instruments.

DDA (R-PDSO-G8)

PowerPAD™ PLASTIC SMALL OUTLINE

THERMAL INFORMATION

This PowerPAD™ package incorporates an exposed thermal pad that is designed to be attached to a printed circuit board (PCB). The thermal pad must be soldered directly to the PCB. After soldering, the PCB can be used as a heatsink. In addition, through the use of thermal vias, the thermal pad can be attached directly to the appropriate copper plane shown in the electrical schematic for the device, or alternatively, can be attached to a special heatsink structure designed into the PCB. This design optimizes the heat transfer from the integrated circuit (IC).

For additional information on the PowerPAD package and how to take advantage of its heat dissipating abilities, refer to Technical Brief, PowerPAD Thermally Enhanced Package, Texas Instruments Literature No. SLMA002 and Application Brief, PowerPAD Made Easy, Texas Instruments Literature No. SLMA004. Both documents are available at www.ti.com.

The exposed thermal pad dimensions for this package are shown in the following illustration.

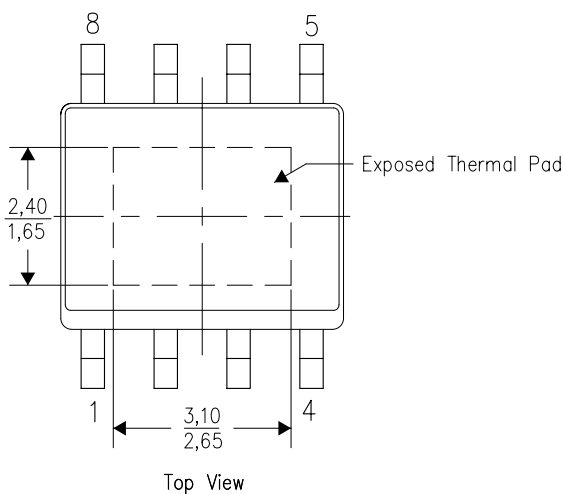

Exposed Thermal Pad Dimensions

4206322-6/K 12/11

NOTE: A. All linear dimensions are in millimeters

PowerPAD is a trademark of Texas Instruments

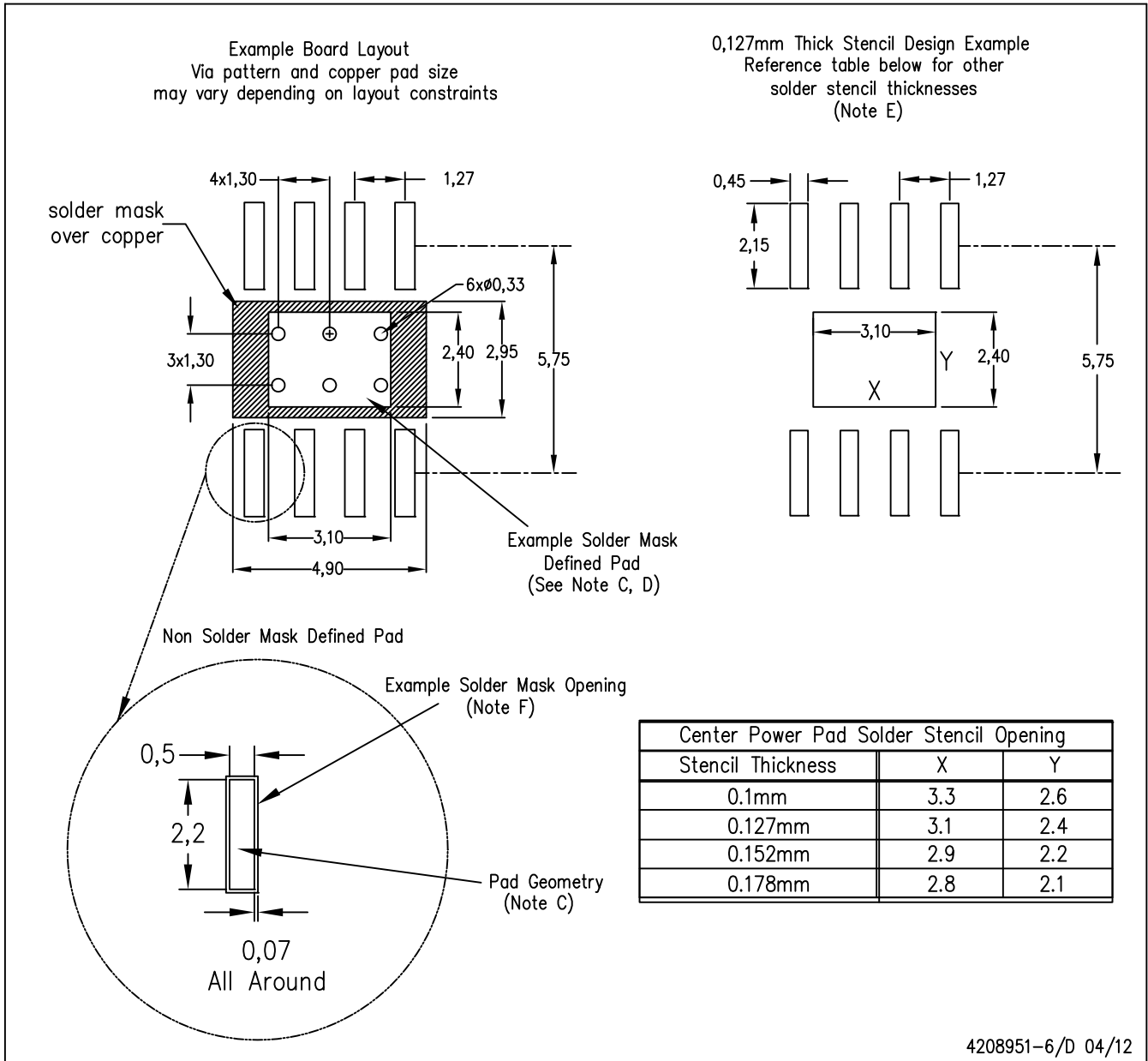

- NOTES:
- A. All linear dimensions are in millimeters.
 - B. This drawing is subject to change without notice.
 - C. Publication IPC-7351 is recommended for alternate designs.
 - D. This package is designed to be soldered to a thermal pad on the board. Refer to Technical Brief, PowerPad Thermally Enhanced Package, Texas Instruments Literature No. SLMA002, SLMA004, and also the Product Data Sheets for specific thermal information, via requirements, and recommended board layout. These documents are available at www.ti.com <<http://www.ti.com>>. Publication IPC-7351 is recommended for alternate designs.
 - E. Laser cutting apertures with trapezoidal walls and also rounding corners will offer better paste release. Customers should contact their board assembly site for stencil design recommendations. Example stencil design based on a 50% volumetric metal load solder paste. Refer to IPC-7525 for other stencil recommendations.
 - F. Customers should contact their board fabrication site for solder mask tolerances between and around signal pads.

PowerPAD is a trademark of Texas Instruments.

IMPORTANT NOTICE

Texas Instruments Incorporated and its subsidiaries (TI) reserve the right to make corrections, modifications, enhancements, improvements, and other changes to its products and services at any time and to discontinue any product or service without notice. Customers should obtain the latest relevant information before placing orders and should verify that such information is current and complete. All products are sold subject to TI's terms and conditions of sale supplied at the time of order acknowledgment.

TI warrants performance of its hardware products to the specifications applicable at the time of sale in accordance with TI's standard warranty. Testing and other quality control techniques are used to the extent TI deems necessary to support this warranty. Except where mandated by government requirements, testing of all parameters of each product is not necessarily performed.

TI assumes no liability for applications assistance or customer product design. Customers are responsible for their products and applications using TI components. To minimize the risks associated with customer products and applications, customers should provide adequate design and operating safeguards.

TI does not warrant or represent that any license, either express or implied, is granted under any TI patent right, copyright, mask work right, or other TI intellectual property right relating to any combination, machine, or process in which TI products or services are used. Information published by TI regarding third-party products or services does not constitute a license from TI to use such products or services or a warranty or endorsement thereof. Use of such information may require a license from a third party under the patents or other intellectual property of the third party, or a license from TI under the patents or other intellectual property of TI.

Reproduction of TI information in TI data books or data sheets is permissible only if reproduction is without alteration and is accompanied by all associated warranties, conditions, limitations, and notices. Reproduction of this information with alteration is an unfair and deceptive business practice. TI is not responsible or liable for such altered documentation. Information of third parties may be subject to additional restrictions.

Resale of TI products or services with statements different from or beyond the parameters stated by TI for that product or service voids all express and any implied warranties for the associated TI product or service and is an unfair and deceptive business practice. TI is not responsible or liable for any such statements.

TI products are not authorized for use in safety-critical applications (such as life support) where a failure of the TI product would reasonably be expected to cause severe personal injury or death, unless officers of the parties have executed an agreement specifically governing such use. Buyers represent that they have all necessary expertise in the safety and regulatory ramifications of their applications, and acknowledge and agree that they are solely responsible for all legal, regulatory and safety-related requirements concerning their products and any use of TI products in such safety-critical applications, notwithstanding any applications-related information or support that may be provided by TI. Further, Buyers must fully indemnify TI and its representatives against any damages arising out of the use of TI products in such safety-critical applications.

TI products are neither designed nor intended for use in military/aerospace applications or environments unless the TI products are specifically designated by TI as military-grade or "enhanced plastic." Only products designated by TI as military-grade meet military specifications. Buyers acknowledge and agree that any such use of TI products which TI has not designated as military-grade is solely at the Buyer's risk, and that they are solely responsible for compliance with all legal and regulatory requirements in connection with such use.

TI products are neither designed nor intended for use in automotive applications or environments unless the specific TI products are designated by TI as compliant with ISO/TS 16949 requirements. Buyers acknowledge and agree that, if they use any non-designated products in automotive applications, TI will not be responsible for any failure to meet such requirements.

Following are URLs where you can obtain information on other Texas Instruments products and application solutions:

Products

Audio	www.ti.com/audio
Amplifiers	amplifier.ti.com
Data Converters	dataconverter.ti.com
DLP® Products	www.dlp.com
DSP	dsp.ti.com
Clocks and Timers	www.ti.com/clocks
Interface	interface.ti.com
Logic	logic.ti.com
Power Mgmt	power.ti.com
Microcontrollers	microcontroller.ti.com
RFID	www.ti-rfid.com
OMAP Mobile Processors	www.ti.com/omap
Wireless Connectivity	www.ti.com/wirelessconnectivity

Applications

Automotive and Transportation	www.ti.com/automotive
Communications and Telecom	www.ti.com/communications
Computers and Peripherals	www.ti.com/computers
Consumer Electronics	www.ti.com/consumer-apps
Energy and Lighting	www.ti.com/energy
Industrial	www.ti.com/industrial
Medical	www.ti.com/medical
Security	www.ti.com/security
Space, Avionics and Defense	www.ti.com/space-avionics-defense
Video and Imaging	www.ti.com/video

TI E2E Community Home Page

e2e.ti.com

Mailing Address: Texas Instruments, Post Office Box 655303, Dallas, Texas 75265
Copyright © 2012, Texas Instruments Incorporated