

Tiva™ C Series TM4C1294 Connected LaunchPad Evaluation Kit

EK-TM4C1294XL

User's Guide



Literature Number: SPMU365C
March 2014–Revised October 2016

1	Board Overview	4
1.1	Kit Contents.....	5
1.2	Using the Connected LaunchPad	5
1.3	Features.....	5
1.4	BoosterPacks.....	6
1.5	Energia.....	6
1.6	Specifications.....	6
2	Hardware Description	7
2.1	Functional Description	7
2.1.1	Microcontroller.....	7
2.1.2	Ethernet Connectivity.....	8
2.1.3	USB Connectivity	8
2.1.4	Motion Control.....	8
2.1.5	User Switches and LED's.....	8
2.1.6	BoosterPacks and Headers	9
2.2	Power Management.....	20
2.2.1	Power Supplies	20
2.2.2	Low Power Modes	21
2.2.3	Clocking	21
2.2.4	Reset.....	21
2.3	Debug Interface.....	21
2.3.1	In-Circuit Debug Interface (ICDI)	21
2.3.2	External Debugger	22
2.3.3	Virtual COM Port	22
3	Software Development	23
3.1	Software Description.....	23
3.2	Source Code	23
3.3	Tool Options	23
3.4	Programming the Connected LaunchPad.....	24
4	References, PCB Layout, and Bill of Materials	25
4.1	References	25
4.2	Component Locations	26
4.3	Bill of Materials	27
5	Schematic	30
	Revision History.....	31

List of Figures

1-1.	Tiva C Series Connected LaunchPad Evaluation Board	4
2-1.	Tiva Connected LaunchPad Evaluation Board Block Diagram	7
2-2.	Default Jumper Locations	20
4-1.	Connected LaunchPad Dimensions and Component Locations	26

List of Tables

1-1.	EK-TM4C1294XL Specifications	6
2-1.	BoosterPack 1 GPIO and Signal Muxing	9
2-2.	BoosterPack 2 GPIO and Signal Muxing	12
2-3.	X11 Breadboard Adapter Odd-Numbered Pad GPIO and Signal Muxing	16
2-4.	X11 Breadboard Adapter Even-Numbered Pad GPIO and Signal Muxing	17
4-1.	Connected LaunchPad Bill of Materials	27

Board Overview

The Tiva™ C Series TM4C1294 Connected LaunchPad Evaluation Board (EK-TM4C1294XL) is a low-cost evaluation platform for ARM® Cortex™-M4F-based microcontrollers. The Connected LaunchPad design highlights the TM4C1294NCPDT microcontroller with its on-chip 10/100 Ethernet MAC and PHY, USB 2.0, hibernation module, motion control pulse-width modulation and a multitude of simultaneous serial connectivity. The Connected LaunchPad also features two user switches, four user LEDs, dedicated reset and wake switches, a breadboard expansion option and two independent BoosterPack XL expansion connectors. The pre-programmed quickstart application on the Connected LaunchPad also enables remote monitoring and control of the evaluation board from an internet browser anywhere in the world. The web interface is provided by 3rd party, Exosite. Each Connected LaunchPad is enabled on the Exosite platform allowing users to create and customize their own Internet-of-Things applications.

Figure 1-1 shows a photo of the Connected LaunchPad with key features highlighted.

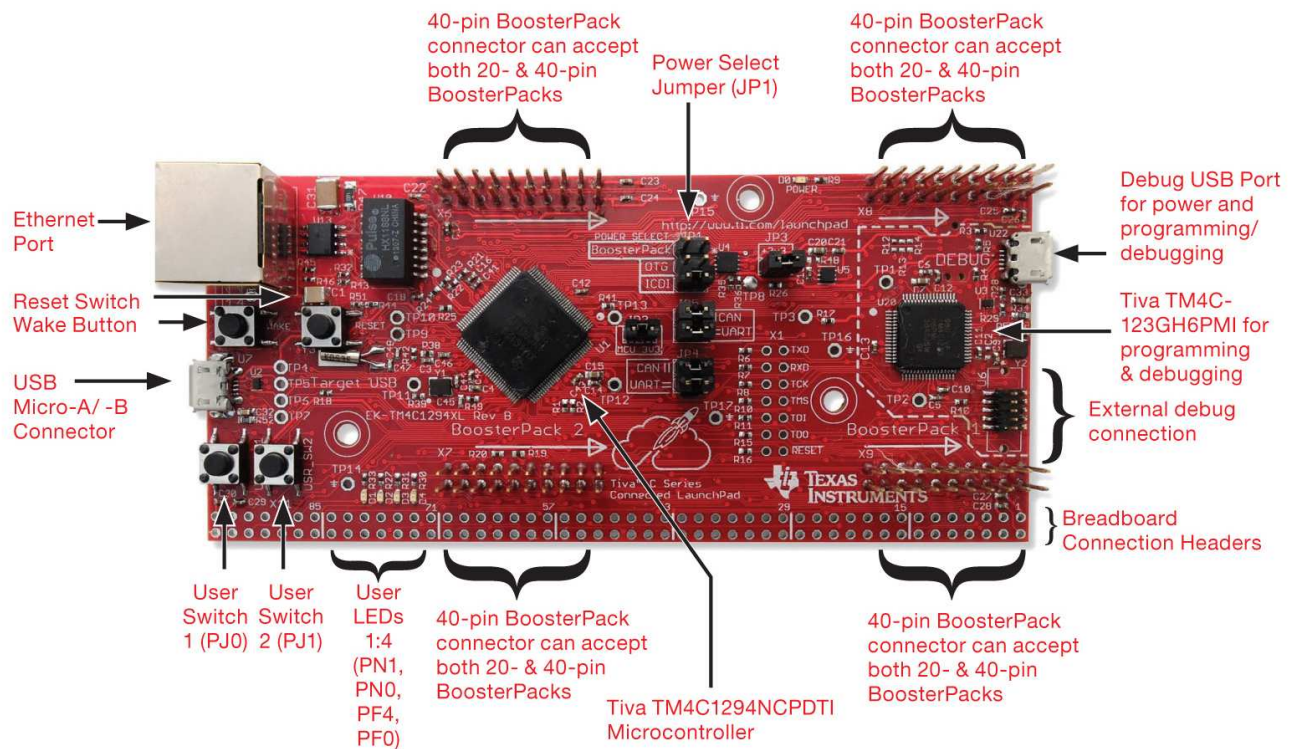

Figure 1-1. Tiva C Series Connected LaunchPad Evaluation Board

Tiva is a trademark of Texas Instruments.
All other trademarks are the property of their respective owners.

1.1 Kit Contents

The Connected LaunchPad Evaluation Kit contains the following items:

- Tiva™ C Series TM4C1294 Evaluation Board (EK-TM4C1294XL)
- Retractable Ethernet cable
- USB Micro-B plug to USB-A plug cable
- [README First](#) document

1.2 Using the Connected LaunchPad

The recommended steps for using the Connected LaunchPad Evaluation Kit are:

1. **Follow the README First document included in the kit.** The README First helps you get the Connected LaunchPad up and running in minutes. Within just a few minutes you can be controlling and monitoring the Connected LaunchPad through the internet using Exosite and the pre-programmed quickstart application.
2. **Experiment with BoosterPacks.** This evaluation kit conforms to the latest revision of the BoosterPack pinout standard. It has two independent BoosterPack connections to enable a multitude of expansion opportunities.
3. **Take the first step towards developing your own applications.** The Connected LaunchPad is supported by TivaWare for C Series. After installing TivaWare, look in the installation directory for *examples\boards\ek-tm4c1294xl*. You can find pre-configured example applications for this board as well as for this board with selected BoosterPacks. Alternately, use Energia for a wiring framework-based cross-platform, fast-prototyping environment that works with this and other TI LaunchPads. See [Chapter 3](#) of this document for more details about software development. TivaWare can be downloaded from the TI website at <http://www.ti.com/tool/sw-tm4c>. Energia can be found at <http://energia.nu>.
4. **Customize and integrate the hardware to suit your end application.** This evaluation kit can be used as a reference for building your own custom circuits based on Tiva C microcontrollers or as a foundation for expansion with your custom BoosterPack or other circuit. This manual can serve as a starting point for this endeavor.
5. **Get Trained.** You can also download hours of written and video training materials on this and related LaunchPads. Visit the Tiva C Series LaunchPad Workshop Wiki for more information.
6. **More Resources.** See the TI MCU LaunchPad web page for more information and available BoosterPacks. (<http://www.ti.com/tiva-c-launchpad>)

1.3 Features

Your Connected LaunchPad includes the following features:

- Tiva TM4C1294NCPDTI microcontroller
- Ethernet connectivity with fully integrated 10/100 Ethernet MAC and PHY Motion Control PWM
- USB 2.0 Micro A/B connector
- 4 user LEDs
- 2 user buttons
- 1 independent hibernate wake switch
- 1 independent microcontroller reset switch
- Jumper for selecting power source:
 - ICDI USB
 - USB Device
 - BoosterPack
- Preloaded Internet-of-Things Exosite quickstart application
- I/O brought to board edge for breadboard expansion
- Two independent BoosterPack XL standard connectors featuring stackable headers to maximize expansion through BoosterPack ecosystem

- For a complete list of BoosterPacks, see the TI MCU LaunchPad web page:
<http://www.ti.com/launchpad>

1.4 BoosterPacks

The Connected LaunchPad provides an easy and inexpensive way to develop applications with the TM4C1294NCPDTI microcontroller. BoosterPacks are add-on boards that follow a pin-out standard created by Texas Instruments. The TI and third-party ecosystem of BoosterPacks greatly expands the peripherals and potential applications that you can easily explore with the Connected LaunchPad.

You can also build your own BoosterPack by following the design guidelines on TI's website. Texas Instruments even helps you promote your BoosterPack to other members of the community. TI offers a variety of avenues for you to reach potential customers with your solutions.

1.5 Energĭa

Energĭa is an open-source electronics prototyping platform started in January of 2012 with the goal of bringing the Wiring and Arduino framework to the TI LaunchPad community. Energĭa includes an integrated development environment (IDE) that is based on Processing.

Together with Energĭa, LaunchPads can be used to develop interactive objects, taking inputs from a variety of switches or sensors, and controlling a variety of lights, motors, and other physical outputs. LaunchPad projects can be stand-alone (only run on the target board, i.e. your LaunchPad), or they can communicate with software running on your computer (Host PC). Energĭa projects are highly portable between supported LaunchPad platforms. Projects written for your Connected LaunchPad can be run on other LaunchPads with little or no modifications.

More information is available at <http://energia.nu>.

1.6 Specifications

Table 1-1 summarizes the specifications for the Connected LaunchPad.

Table 1-1. EK-TM4C1294XL Specifications

Parameter	Value
Board Supply Voltage	4.75 V _{DC} to 5.25 V _{DC} from one of the following sources: <ul style="list-style-type: none"> • Debug USB U22 (ICDI) USB Micro-B cable connected to PC or other compatible power source. • Target USB (U7) USB Micro-B cable connected to PC or other compatible power source. • BoosterPack 1 (X8-4) • BoosterPack 2 (X6-4) • Breadboard expansion header (X11-2 or X11-97). See schematic symbol JP1 for power input selection.
Dimensions	4.9 in x 2.2 in x .425 in (12.45 cm x 5.59 cm x 10.8 mm) (L x W x H)
Break-out Power Output	<ul style="list-style-type: none"> • 5 V_{DC} to BoosterPacks, current limited by TPS2052B. Nominal rating 1 Amp. Board input power supply limitations may also apply. • 3.3 V_{DC} to BoosterPacks, limited by output of TPS73733 LDO. This 3.3-V plane is shared with on-board components. Total output power limit of TPS73733 is 1 Amp.
RoHS Status	Compliant

Hardware Description

The Connected LaunchPad includes a TM4C1294NCPDTI microcontroller with an integrated 10/100 Ethernet MAC and PHY. This advanced ARM® Cortex™ M4F MCU has a wide range of peripherals that are made available to users via the on-board accessories and the BoosterPack connectors. This chapter explains how those peripherals operate and interface to the microcontroller.

Figure 2-1 provides a high-level block diagram of the Connected LaunchPad.

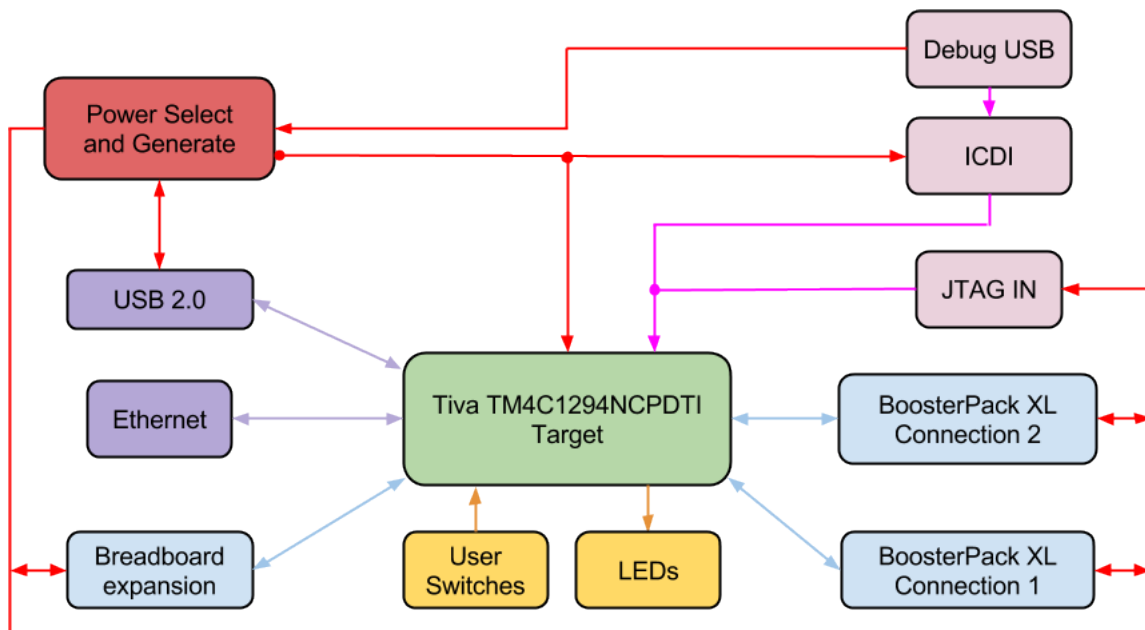

Figure 2-1. Tiva Connected LaunchPad Evaluation Board Block Diagram

2.1 Functional Description

2.1.1 Microcontroller

The TM4C1294NCPDTI is a 32-bit ARM Cortex-M4F based microcontroller with 1024-kB Flash memory, 256-kB SRAM, 6-kB EEPROM, and 120 MHz operation; integrated 10/100 Ethernet MAC and PHY; integrated USB 2.0 connectivity with external high-speed USB 3.0 PHY capability; a hibernation module, a multitude of serial connectivity and motion control PWM; as well as a wide range of other peripherals. See the TM4C1294NCPDTI microcontroller [data sheet](#) for more complete details.

Most of the microcontroller's signals are routed to 0.1-in (2.54-mm) pitch headers or through-hole solder pads. An internal multiplexor allows different peripheral functions to be assigned to each of these GPIO pads. When adding external circuitry, consider the additional load on the evaluation board power rails.

The TM4C1294NCPDTI microcontroller is factory-programmed with a quickstart demo program. The quickstart program resides in on-chip Flash memory and runs each time power is applied, unless the quickstart application has been replaced with a user program. The quickstart application automatically connects to <http://ti.exosite.com> when an internet connection is provided through the RJ45 Ethernet jack on the evaluation board.

2.1.2 Ethernet Connectivity

The Connected LaunchPad is designed to connect directly to an Ethernet network using RJ45 style connectors. The microcontroller contains a fully integrated Ethernet MAC and PHY. This integration creates a simple, elegant and cost-saving Ethernet circuit design. Example code is available for both the uIP and LwIP TCP/IP protocol stacks. The embedded Ethernet on this device can be programmed to act as an HTTP server, client or both. The design and integration of the circuit and microcontroller also enable users to synchronize events over the network using the IEEE1588 precision time protocol.

When configured for Ethernet operation, it is recommended that the user configure LED D3 and D4 to be controlled by the Ethernet MAC to indicate connection and transmit/receive status.

2.1.3 USB Connectivity

The Connected LaunchPad is designed to be USB 2.0 ready. A TPS2052B load switch is connected to and controlled by the microcontroller USB peripheral, which manages power to the USB micro A/B connector when functioning in a USB host. When functioning as a USB device, the entire Connected LaunchPad can be powered directly from the USB micro A/B connector. Use JP1 to select the desired power source.

USB 2.0 functionality is provided and supported directly out of the box with the target USB micro A/B connector. High-speed USB 3.0 functionality can be enabled by adding an external USB PHY. The USB external PHY control and data signals are provided on the breadboard expansion header X11.

2.1.4 Motion Control

The Connected LaunchPad includes the Tiva C Series Motion Control PWM technology, featuring a PWM module capable of generating eight PWM outputs. The PWM module provides a great deal of flexibility and can generate simple PWM signals – for example, those required by a simple charge pump – as well as paired PWM signals with dead-band delays, such as those required by a half-H bridge driver. Three generator blocks can also generate the full six channels of gate controls required by a 3-phase inverter bridge.

A quadrature encoder interface (QEI) is also available to provide motion control feedback.

See the [BoosterPacks and Headers](#) section of this document for details about the availability of these signals on the BoosterPack interfaces.

2.1.5 User Switches and LED's

Two user switches are provided for input and control of the TM4C1294NCPDTI software. The switches are connected to GPIO pins PJ0 and PJ1.

A reset switch and a wake switch are also provided. The reset switch initiates a system reset of the microcontroller whenever it is pressed and released. Pressing the reset switch also asserts the reset signal to the BoosterPack and Breadboard headers. The wake switch is one way to bring the device out of hibernate mode.

Four user LEDs are provided on the board. D1 and D2 are connected to GPIOs PN1 and PN0. These LEDs are dedicated for use by the software application. D3 and D4 are connected to GPIOs PF4 and PF0, which can be controlled by user's software or the integrated Ethernet module of the microcontroller.

A power LED is also provided to indicate that 3.3 volt power is present on the board.

2.1.6 BoosterPacks and Headers

2.1.6.1 BoosterPack 1

The Connected LaunchPad features two fully independent BoosterPack XL connectors. BoosterPack 1, located around the ICDI portion of the board, is fully compliant with the BoosterPack standard with the single exception of GPIO pin PA6 (X8-16), which does not provide analog capability. PA6 is located near the bottom of the inner left BoosterPack XL header.

I2C is provided in both the original BoosterPack standard configuration as well as the updated standard location. Use of I2C on the bottom left of the BoosterPack connections per the updated standard is highly encouraged whenever possible.

Motion control advanced PWM connections are provided on the inner right connector for motion control applications.

Table 2-1 provides a complete listing of the BoosterPack pins and the GPIO alternate functions available on each pin. The TM4C1294NCPDTI GPIO register GPIOCTL values are shown for each configuration. The headers in this table are labeled from left to right in ten pin columns. 'A' and 'D' make up the outer BoosterPack standard pins, 'B' and 'C' make up the inner BoosterPack XL standard pins.

Table 2-1. BoosterPack 1 GPIO and Signal Muxing

Header	Pin	Standard Function	GPIO	MCU Pin	Analog	Digital Function (GPIOCTL Bit Encoding)											
						1	2	3	5	6	7	8	11	13	14	15	
A1	1	+3.3 volts	3.3V														
A1	2	Analog	PE4	123	AIN9	U1RI	-	-	-	-	-	-	-	-	-	SSI1XDAT0	
A1	3	UART RX	PC4	25	C1-	U7Rx	-	-	-	-	-	-	-	-	-	EPI0S7	
A1	4	UART TX	PC5	24	C1+	U7Tx	-	-	-	-	RTCCLK	-	-	-	-	EPI0S6	
A1	5	GPIO	PC6	23	C0+	U5Rx	-	-	-	-	-	-	-	-	-	EPI0S5	
A1	6	Analog	PE5	124	AIN8	-	-	-	-	-	-	-	-	-	-	SSIXDAT1	
A1	7	SPI CLK	PD3	4	AIN12	-	I2C8SDA	T1CCP1	-	-	-	-	-	-	-	SSI2CLK	
A1	8	GPIO	PC7	22	C0-	U5Tx	-	-	-	-	-	-	-	-	-	EPI0S4	
A1	9	I2C SCL	PB2	91	-	-	I2C0SCL	T5CCP0	-	-	-	-	-	-	-	USB0STP	EPI0S27
A1	10	I2C SDA	PB3	92	-	-	I2C0SDA	T5CCP1	-	-	-	-	-	-	-	USB0CLK	EPI0S28
B1	1	+5 volts	5V														
B1	2	ground	GND														
B1	3	Analog	PE0	15	AIN3	U1RTS	-	-	-	-	-	-	-	-	-	-	
B1	4	Analog	PE1	14	AIN2	U1DSR	-	-	-	-	-	-	-	-	-	-	
B1	5	Analog	PE2	13	AIN1	U1DCD	-	-	-	-	-	-	-	-	-	-	
B1	6	Analog	PE3	12	AIN0	U1DTR	-	-	-	-	-	-	-	-	-	-	
B1	7	Analog	PD7	128	AIN4	U2CTS	-	T4CCP1	USB0PFLT	-	-	NMI	-	-	-	SSI2XDAT2	
B1	8	Analog	PA6	40	-	U2Rx	I2C6SCL	T3CCP0	USB0EPEN	-	-	-	-	SSI0XDAT2	-	EPI0S8	
B1	9	A out	PM4	74	TMPR3	U0CTS	-	T4CCP0	-	-	-	-	-	-	-	-	
B1	10	A out	PM5	73	TMPR2	U0DCD	-	T4CCP1	-	-	-	-	-	-	-	-	

Table 2-1. BoosterPack 1 GPIO and Signal Muxing (continued)

Header	Pin	Standard Function	GPIO	MCU Pin	Analog	Digital Function (GPIOCTL Bit Encoding)										
						1	2	3	5	6	7	8	11	13	14	15
C1	1	PWM	PF1	43	-	-	-	-	EN0LED2	M0PWM1	-	-	-	-	SSI3XDAT0	TRD1
C1	2	PWM	PF2	44	-	-	-	-	-	M0PWM2	-	-	-	-	SSI3Fss	TRD0
C1	3	PWM	PF3	45	-	-	-	-	-	M0PWM3	-	-	-	-	SSI3Clk	TRCLK
C1	4	PWM	PG0	49	-	-	I2C1SCL	-	EN0PPS	M0PWM4	-	-	-	-	-	EPI0S11
C1	5	Capture	PL4	85	-	-	-	T0CCP0	-	-	-	-	-	-	USB0D4	EPI0S26
C1	6	Capture	PL5	86	-	-	-	T0CCP1	-	-	-	-	-	-	USB0D5	EPI0S33
C1	7	GPIO	PL0	81	-	-	I2C2SDA	-	-	M0FAULT3	-	-	-	-	USB0D0	EPI0S16
C1	8	GPIO	PL1	82	-	-	I2C2SCL	-	-	PhA0	-	-	-	-	USB0D1	EPI0S17
C1	9	GPIO	PL2	83	-	-	-	-	C0o	PhB0	-	-	-	-	USB0D2	EPI0S18
C1	10	GPIO	PL3	84	-	-	-	-	C1o	IDX0	-	-	-	-	USB0D3	EPI0S19
D1	1	ground	GND													
D1	2	PWM	PM3	75	-	-	-	T3CCP1	-	-	-	-	-	-	-	EPI0S12
D1	3	GPIO	PH2	31	-	U0DCD	-	-	-	-	-	-	-	-	-	EPI0S2
D1	4	GPIO	PH3	32	-	U0DSR	-	-	-	-	-	-	-	-	-	EPI0S3
D1	5	reset	RESET													
D1	6	SPI MOSI	PD1	2	AIN14	-	I2C7SDA	T0CCP1	C1o	-	-	-	-	-	-	SSI2XDAT0
D1	7	SPI MISO	PD0	1	AIN15	-	I2C7SCL	T0CCP0	C0o	-	-	-	-	-	-	SSI2XDAT1
D1	8	GPIO	PN2	109	-	U1DCD	U2RTS	-	-	-	-	-	-	-	-	EPI0S29
D1	9	GPIO	PN3	110	-	U1DSR	U2CTS	-	-	-	-	-	-	-	-	EPI0S30
D1	10	GPIO	PP2	103	-	U0DTR	-	-	-	-	-	-	-	-	USB0NXT	EPI0S29

2.1.6.2 BoosterPack 2

The second BoosterPack XL interface is located near the middle of the board. This interface is fully compliant with the BoosterPack standard, and adds features not covered by the BoosterPack standard that enable operation with additional BoosterPacks.

An additional analog signal is provided on the outer left header (X6-9). This signal can be used to monitor the touch panel on the popular Kentec EB-LM4F120-L35 BoosterPack.

Using the jumpers JP4 and JP5, Controller Area Network (CAN) digital receive and transmit signals can be optionally routed to the BoosterPack 2 interface. The location of these signals is consistent with the CAN interface on the Tiva C Series TM4C123G LaunchPad and the Stellaris LM4F120 LaunchPad. In the default configuration, UART0 is used for the ICDI virtual UART and CAN is not present on the BoosterPack headers. In this configuration, the ROM serial bootloader can be used over the ICDI virtual UART. When the jumpers are configured for CAN on the BoosterPack, then UART2 must be used for the ICDI virtual UART.

To comply with both the original and the new BoosterPack standard, I2C is provided on both sides of the BoosterPack connection. Use of I2C on the bottom left of the BoosterPack connection is highly encouraged where possible, to be in compliance with the new BoosterPack standard. To provide I2C capability on the right side of the connector, per the original standard, two zero-ohm resistors (R19 and R20) are used to combine the SPI and I2C signals. These signals are not shared with any other pins on the LaunchPad and therefore removal of these zero-ohm resistors should not be required. Software should be certain that unused GPIO signals are configured as inputs.

Table 2-2 provides a complete listing of the BoosterPack pins and the GPIO alternate functions available at each pin. The TM4C1294NCPDT GPIO register GPIOCTL values are shown for each configuration. The headers in this table are labeled from left to right in ten pin columns. 'A' and 'D' make up the outer BoosterPack standard pins, 'B' and 'C' make up the inner BoosterPack XL standard pins.

Table 2-2. BoosterPack 2 GPIO and Signal Muxing

Header	Pin	Standard Function	GPIO	MCU Pin	Analog	Digital Function (FPIOCTL Bit Encoding)										
						1	2	3	5	6	7	8	11	13	14	15
A2	1		3.3V													
A2	2	Analog	PD2	3	AIN13	-	I2C8SCL	T1CCP0	C2o	-	-	-	-	-	-	SSI2Fss
A2	3	UART RX	PP0	118	C2+	U6Rx	-	-	-	-	-	-	-	-	-	SSI3XDAT2
A2	4	UART TX	PP1	119	C2-	U6Tx	-	-	-	-	-	-	-	-	-	SSI3XDAT3
A2	5	GPIO (See JP4)	PD4	125	AIN7	U2Rx	-	T3CCP0	-	-	-	-	-	-	-	SSI1XDAT2
			PA0	33	-	U0Rx	I2C9SCL	T0CCP0	-	-	CANORx	-	-	-	-	-
A2	6	Analog (See JP5)	PD5	126	AIN6	U2Tx	-	T3CCP1	-	-	-	-	-	-	-	SSI1XDAT3
			PA1	34	-	U0Tx	I2C9SDA	T0CCP1	-	-	CAN0Tx	-	-	-	-	-
A2	7	SPI CLK	PQ0	5	-	-	-	-	-	-	-	-	-	-	SSI3Clk	EPI0S20
A2	8	GPIO	PP4	105	-	U3RTS	U0DSR	-	-	-	-	-	-	-	USB0D7	-
A2	9	I2C SCL	PN5	112	-	U1RI	U3CTS	I2C2SCL	-	-	-	-	-	-	-	EPIO0S35
A2	10	I2C SDA	PN4	111	-	U1DTR	U3RTS	I2C2SDA	-	-	-	-	-	-	-	EPIO0S34
B2	1		5V													
B2	2		GND													
B2	3	Analog	PB4	121	AIN10	U0CTS	I2C5SCL	-	-	-	-	-	-	-	-	SSI1Fss

Table 2-2. BoosterPack 2 GPIO and Signal Muxing (continued)

Header	Pin	Standard Function	GPIO	MCU Pin	Analog	Digital Function (FPIOPTL Bit Encoding)										
						1	2	3	5	6	7	8	11	13	14	15
B2	4	Analog	PB5	120	AIN11	U0RTS	I2C5SDA	-	-	-	-	-	-	-	-	SSI1Clk
B2	5	Analog	PK0	18	AIN16	U4Rx	-	-	-	-	-	-	-	-	-	EPI0S0
B2	6	Analog	PK1	19	AIN17	U4Tx	-	-	-	-	-	-	-	-	-	EPI0S1
B2	7	Analog	PK2	20	AIN18	U4RTS	-	-	-	-	-	-	-	-	-	EPI0S2
B2	8	Analog	PK3	21	AIN19	u4CTS	-	-	-	-	-	-	-	-	-	EPI0S3
B2	9	A out	PA4	37	-	U3Rx	I2C7SCL	T2CCP0	-	-	-	-	-	-	-	SSI0XDAT0
B2	10	A out	PA5	38	-	U3Tx	I2C7SDA	T2CCP1	-	-	-	-	-	-	-	SSI0XDAT1
C2	1	PWM	PG1	50	-	-	I2C1SDA	-	-	M0PWM5	-	-	-	-	-	EPI0S10
C2	2	PWM	PK4	63	-	-	I2C3SCL	-	EN0LED0	M0PWM6	-	-	-	-	-	EPI0S32
C2	3	PWM	PK5	62	-	-	I2C3SDA	-	EN0LED2	M0PWM7	-	-	-	-	-	EPI0S31
C2	4	PWM	PM0	78	-	-	-	T2CCP0	-	-	-	-	-	-	-	EPI0S15
C2	5	Capture	PM1	77	-	-	-	T2CCP1	-	-	-	-	-	-	-	EPI0S14
C2	6	Capture	PM2	76	-	-	-	T3CCP0	-	-	-	-	-	-	-	EPI0S13
C2	7	GPIO	PH0	29	-	U0RTS	-	-	-	-	-	-	-	-	-	EPI0S0
C2	8	GPIO	PH1	30	-	U0CTS	-	-	-	-	-	-	-	-	-	EPI0S1
C2	9	GPIO	PK6	61	-	-	I2C4SCL	-	EN0LED1	M0FAULT1	-	-	-	-	-	EPI0S25
C2	10	GPIO	PK7	60	-	U0RI	I2C4SDA	-	RTCCLK	M0FAULT2	-	-	-	-	-	EPI0S24
D2	1					GND										
D2	2	PWM	PM7	71	TMPR0	U0RI	-	T5CCP1	-	-	-	-	-	-	-	-
D2	3	GPIO	PP5	106	-	U3CTS	I2C2SDL	-	-	-	-	-	-	-	USB0D6	-
D2	4	GPIO	PA7	41	-	U2Tx	I2C6SDA	T3CCP1	USB0PFLT	-	-	-	USB0EPEN	SSI0XDAT3	-	EPI0S9
D2	5					RESET										
D2	6	SPI MOSI	PQ2	11	-	-	-	-	-	-	-	-	-	-	SSI3XDAT0	EPI0S22
		I2C	PA3	36	-	U4Tx	I2C8SDA	T1CCP1	-	-	-	-	-	-	-	SSI0Fss
D2	7	SPI MISO	PQ3	27	-	-	-	-	-	-	-	-	-	-	SSI3XDAT1	EPI0S23
		I2C	PA2	35	-	U4Rx	I2C8SCL	T1CCP0	-	-	-	-	-	-	-	SSI0Clk
D2	8	GPIO	PP3	104	-	U1CTS	U0DCD	-	-	-	-	-	-	-	USB0DIR	EPI0S30
D2	9	GPIO	PQ1	6	-	-	-	-	-	-	-	-	-	-	SSI3Fss	EPI0S21
D2	10	GPIO	PM6	72	TMPR1	U0DSR	-	T5CCP0	-	-	-	-	-	-	-	-

2.1.6.3 Breadboard Connection

The breadboard adapter section of the board is a set of 98 holes on a 0.1 inch grid. Properly combined with a pair of right angle headers, the entire Connected LaunchPad can be plugged directly into a standard 300 mil (0.3 inch) wide solder-less breadboard. The right angle headers and breadboard are not provided with this kit. Suggested part numbers are Samtec TSW-149-09-L-S-RE and TSW-149-08-L-S-RA right angle pin headers and Twin industries TW-E40-1020 solder-less breadboard. Samtec TSW-149-09-F-S-RE and TSW-149-09-F-S-RA may be substituted.

A detailed explanation of how to install the headers is available on the TI LaunchPad Wiki or at <http://users.ece.utexas.edu/~valvano/EE345L/Labs/Fall2011/LM3S1968soldering.pdf>.

Nearly all microcontroller signals are made available at the breadboard adapter holes (X11). These signals are grouped by function where possible. For example, all EPI signals are grouped on one side of the connector. Many of the analog signals are grouped near VREF, and UART, SSI and I2C signals are grouped by peripheral to make expansion and customization simpler.

[Table 2-3](#) and [Table 2-4](#) show the GPIO pin and signal muxing for the X11 breadboard adapter pads.

Table 2-3. X11 Breadboard Adapter Odd-Numbered Pad GPIO and Signal Muxing

Pin	Port	MCU PIN	Analog	Digital Function (GPIOCTL Bit Encoding)										
				1	2	3	5	6	7	8	11	13	14	15
1				3V3										
3				GND										
5	PB4	121	AIN10	U0CTS	I2C5SCL	-	-	-	-	-	-	-	-	SSI1Fss
7	PB5	120	AIN11	U0RTS	I2C5SDA	-	-	-	-	-	-	-	-	SSI1Clk
9	PH0	29	-	U0RTS	-	-	-	-	-	-	-	-	-	EPI0S0
11	PH1	30	-	U0CTS	-	-	-	-	-	-	-	-	-	EPI0S1
13	PH2	31	-	U0DCD	-	-	-	-	-	-	-	-	-	EPI0S2
15	PH3	32	-	U0DSR	-	-	-	-	-	-	-	-	-	EPI0S3
17	PC7	22	C0-	U5Tx	-	-	-	-	-	-	-	-	-	EPI0S4
19	PC6	23	C0+	U5Rx	-	-	-	-	-	-	-	-	-	EPI0S5
21	PC5	24	C1+	U7Tx	-	-	-	-	RTCCLK	-	-	-	-	EPI0S6
23	PC4	25	C1-	U7Rx	-	-	-	-	-	-	-	-	-	EPI0S7
25	PA6	40	-	U2Rx	I2C6SCL	T3CCP0	USB0EPEN	-	-	-	-	SSI0XDAT2	-	EPI0S8
27	PA7	41	-	U2Tx	I2C6SDA	T3CCP1	USB0PFLT	-	-	-	USB0EPEN	SSI0XDAT3	-	EPI0S9
29	PG1	50	-	-	I2C1SDA	-	-	M0PWM5	-	-	-	-	-	EPI0S10
31	PG0	49	-	-	I2C1SCL	-	EN0PPS	M0PWM4	-	-	-	-	-	EPI0S11
33	PM3	75	-	-	-	T3CCP1	-	-	-	-	-	-	-	EPI0S12
35				GND										
37	PM2	76	-	-	-	T3CCP0	-	-	-	-	-	-	-	EPI0S13
39	PM1	77	-	-	-	T2CCP1	-	-	-	-	-	-	-	EPI0S14
41	PM0	78	-	-	-	T2CCP0	-	-	-	-	-	-	-	EPI0S15
43	PL0	81	-	-	I2C2SDA	-	-	M0FAULT3	-	-	-	-	USB0D0	EPI0S16
45	PL1	82	-	-	I2C2SCL	-	-	PhA0	-	-	-	-	USB0D1	EPI0S17
47	PL2	83	-	-	-	-	C0o	PhB0	-	-	-	-	USB0D2	EPI0S18
49	PL3	84	-	-	-	-	C1o	IDX0	-	-	-	-	USB0D3	EPI0S19
51	PQ0	5	-	-	-	-	-	-	-	-	-	-	SSI3Clk	EPI0S20
53	PQ1	6	-	-	-	-	-	-	-	-	-	-	SSI3Fss	EPI0S21
55	PQ2	11	-	-	-	-	-	-	-	-	-	-	SSI3XDAT0	EPI0S22
57	PQ3	27	-	-	-	-	-	-	-	-	-	-	SSI3XDAT1	EPI0S23
59	PK7	60	-	U0RI	I2C4SDA	-	-	-	-	-	-	-	-	EPI0S24
61				GND										
63	PK6	61	-	-	I2C4SCL	-	EN0LED1	M0FAULT1	-	-	-	-	-	EPI0S25
65	PL4	85	-	-	-	T0CCP0	-	-	-	-	-	-	USB0D4	EPI0S26

Table 2-3. X11 Breadboard Adapter Odd-Numbered Pad GPIO and Signal Muxing (continued)

Pin	Port	MCU PIN	Analog	Digital Function (GPIOCTL Bit Encoding)											
				1	2	3	5	6	7	8	11	13	14	15	
67	PB2	91	-	-	I2C0SCL	T5CCP0	-	-	-	-	-	-	-	USB0STP	EPI0S27
69	PB3	92	-	-	I2C0SDA	T5CCP1	-	-	-	-	-	-	-	USB0CLK	EPI0S28
71	PP2	103	-	U0DTR	-	-	-	-	-	-	-	-	-	USB0NXT	EPI0S29
73	PP3	104	-	U1CTS	U0DCD	-	-	-	RTCCLK	-	-	-	-	USB0DIR	EPI0S30
75	PK5	62	-	-	I2C3SDA	-	EN0LED2	M0PWM7	-	-	-	-	-	-	EPI0S31
77	PK4	63	-	-	I2C3SCL	-	EN0LED0	M0PWM6	-	-	-	-	-	-	EPI0S32
79	PL5	86	-	-	-	T0CCP1	-	-	-	-	-	-	-	USB0D5	EPI0S33
81	PN4	111	-	U1DTR	U3RTS	I2C2SDA	-	-	-	-	-	-	-	-	EPI0S34
83	PN5	112	-	U1RI	U3CTS	I2C2SCL	-	-	-	-	-	-	-	-	EPI0S35
85	PN0	107	-	U1RTS	-	-	-	-	-	-	-	-	-	-	-
87	PN1	108	-	U1CTS	-	-	-	-	-	-	-	-	-	-	-
89	PN2	109	-	U1DCD	U2RTS	-	-	-	-	-	-	-	-	-	EPI0S29
91	PN3	110	-	U1DSR	U2CTS	-	-	-	-	-	-	-	-	-	EPI0S30
93	PQ4	102	-	U1Rx	-	-	-	-	-	DIVSCLK	-	-	-	-	-
95	WAKE														
97	5V														

Table 2-4. X11 Breadboard Adapter Even-Numbered Pad GPIO and Signal Muxing

Pin	Port	MCU PIN	Analog	Digital Function (GPIOCTL Bit Encoding)											
				1	2	3	5	6	7	8	11	13	14	15	
2	5V														
4	GND														
6	PA2	35	-	U4Rx	I2C8SCL	T1CCP0	-	-	-	-	-	-	-	-	SSI0Clk
8	PA3	36	-	U4Tx	I2C8SDA	T1CCP1	-	-	-	-	-	-	-	-	SSI0Fss
10	PA4	37	-	U3Rx	I2C7SCL	T2CCP0	-	-	-	-	-	-	-	-	SSI0XDAT0
12	PA5	38	-	U3Tx	I2C7SDA	T2CCP1	-	-	-	-	-	-	-	-	SSI0XDAT1
14	PE0	15	AIN3	U1RTS	-	-	-	-	-	-	-	-	-	-	-
16	PE1	14	AIN2	U1DSR	-	-	-	-	-	-	-	-	-	-	-
18	PE2	13	AIN1	U1DCD	-	-	-	-	-	-	-	-	-	-	-
20	PE3	12	AIN0	U1DTR	-	-	-	-	-	-	-	-	-	-	-
22	PE4	123	AIN9	U1RI	-	-	-	-	-	-	-	-	-	-	SSI1XDAT0
24	PE5	124	AIN8	-	-	-	-	-	-	-	-	-	-	-	SSI1XDAT1

Table 2-4. X11 Breadboard Adapter Even-Numbered Pad GPIO and Signal Muxing (continued)

Pin	Port	MCU PIN	Analog	Digital Function (GPIOCTL Bit Encoding)										
				1	2	3	5	6	7	8	11	13	14	15
26	PK0	18	AIN16	U4Rx	-	-	-	-	-	-	-	-	-	EPI0S0
28	PK1	19	AIN17	U4Tx	-	-	-	-	-	-	-	-	-	EPI0S1
30	PK2	20	AIN18	U4RTS	-	-	-	-	-	-	-	-	-	EPI0S2
32	PK3	21	AIN19	U4CTS	-	-	-	-	-	-	-	-	-	EPI0S3
34	VREF													
36	GND													
38	PD5	126	AIN6	U2Tx	-	T3CCP1	-	-	-	-	-	-	-	SSI1XDAT3
40	PD4	125	AIN7	U2Rx	-	T3CCP0	-	-	-	-	-	-	-	SSI1XDAT2
42	PD7	128	AIN4	U2CTS	-	T4CCP1	USB0PFLT	-	-	NMI	-	-	-	SSI2XDAT2
44	PD6	127	AIN5	U2RTS	-	T4CCP0	USB0EPEN	-	-	-	-	-	-	SSI2XDAT3
46	PD3	4	AIN12	-	I2C8SDA	T1CCP1	-	-	-	-	-	-	-	SSI2CIk
48	PD1	2	AIN14	-	I2C7SDA	T0CCP1	C1o	-	-	-	-	-	-	SSI2XDAT0
50	PD0	1	AIN15	-	I2C7SCL	T0CCP0	C0o	-	-	-	-	-	-	SSI2XDAT1
52	PD2	3	AIN13	-	I2C8SCL	T1CCP0	C2o	-	-	-	-	-	-	SSI2Fss
54	PP0	118	C2+	U6Rx	-	-	-	-	-	-	-	-	-	SSI3XDAT2
56	PP1	119	C2-	U6Tx	-	-	-	-	-	-	-	-	-	SSI3XDAT3
58	PB0	95	USB0ID	U1Rx	I2C5SCL	T4CCP0	-	-	CAN1Rx	-	-	-	-	-
60	PB1	96	USB0VBUS	U1Tx	I2C5SDA	T4CCP1	-	-	CAN1Tx	-	-	-	-	-
62	GND													
64	PF4	46	-	-	-	-	EN0LED1	M0FAULT0	-	-	-	-	SSI3XDAT2	TRD3
66	PF0	42	-	-	-	-	EN0LED0	M0PWM0	-	-	-	-	SSI3XDAT1	TRD2
68	PF1	43	-	-	-	-	EN0LED2	M0PWM1	-	-	-	-	SSI3XDAT0	TRD1
70	PF2	44	-	-	-	-	-	M0PWM2	-	-	-	-	SSI3Fss	TRD0
72	PF3	45	-	-	-	-	-	M0PWM3	-	-	-	-	SSI3CIk	TRCLK
74	PA0	33	-	U0Rx	I2C9SCL	T0CCP0	-	-	CAN0Rx	-	-	-	-	-
76	PA1	34	-	U0Tx	I2C9SDA	T0CCP1	-	-	CAN0Tx	-	-	-	-	-
78	PP4	105	-	U3RTS	U0DSR	-	-	-	-	-	-	-	USB0D7	-
80	PP5	106	-	U3CTS	I2C2SCL	-	-	-	-	-	-	-	USB0D6	-
82	PJ0	116	-	U3Rx	-	-	-	-	-	-	-	-	-	-
84	PJ1	117	-	U3Tx	-	-	-	-	-	-	-	-	-	-
86	PM7	71	TMPR0	U0RI	-	T5CCP1	-	-	-	-	-	-	-	-
88	PM6	72	TMPR1	U0DSR	-	T5CCP0	-	-	-	-	-	-	-	-
90	PM5	73	TMPR2	U0DCD	-	T4CCP1	-	-	-	-	-	-	-	-

Table 2-4. X11 Breadboard Adapter Even-Numbered Pad GPIO and Signal Muxing (continued)

Pin	Port	MCU PIN	Analog	Digital Function (GPIOCTL Bit Encoding)										
				1	2	3	5	6	7	8	11	13	14	15
92	PM4	74	TMPR3	U0CTS	-	T4CCP0	-	-	-	-	-	-	-	-
94				RESET										
96				GND										
98				3V3										

2.1.6.4 Other Headers and Jumpers

JP1 is provided to select the power input source for the Connected LaunchPad. The top position is for BoosterPack power; this position also disconnects both USB voltages from the board's primary 5-volt input. In the top position, the TPS2052B does not limit current so additional care should be exercised. The middle position draws power from the USB connector on the left side of the board near the Ethernet jack. The bottom position is the default, in which power is drawn from the ICDI (Debug) USB connection.

JP2 separates the MCU 3.3-volt power domain from the rest of the 3.3-volt power on the board allowing an ammeter to be used to obtain more accurate measurements of microcontroller power consumption.

JP3 isolates the output of the TPS73733 LDO from the board's 3.3-V power domain.

JP4 and JP5 are used to configure CAN signals to the BoosterPack 2 interface. In the default horizontal configuration, CAN is not present on the BoosterPack. UART2 goes to the BoosterPack and UART 0 goes to the ICDI virtual serial port to provide ROM serial bootloader capability. In the vertical CAN-enabled configuration, UART2 goes to the ICDI virtual serial port and CAN signals are available on the BoosterPack. The ROM serial bootloader is not available to the ICDI virtual serial port while the jumpers are in the CAN position.

Figure 2-2 shows the default configuration and relative location of the jumpers on the board.

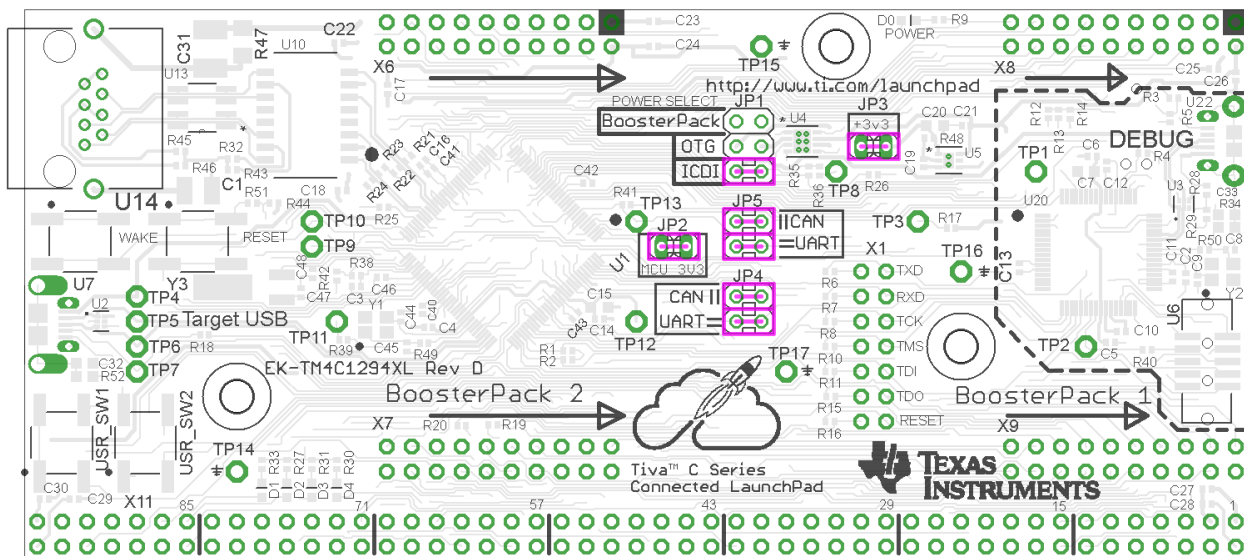

Figure 2-2. Default Jumper Locations

2.2 Power Management

2.2.1 Power Supplies

The Connected LaunchPad can be powered from three different input options:

- On-board ICDI USB cable (Debug, Default)
- Target USB cable
- BoosterPack or Breadboard adapter connection

The JP1 power-select jumper is used to select one of the power sources.

In addition, the JP3 power jumper can be used to isolate the 3.3-volt output of the TPS73733 from the board's 3.3-volt rail.

A TPS2052B load switch is used to regulate and control power to the Target USB connector when the microcontroller is acting in USB host mode. This load switch also limits current to the BoosterPack and Breadboard adapter headers when the JP1 jumper is in the ICDI position.

2.2.2 Low Power Modes

The Connected LaunchPad demonstrates several low power microcontroller modes. In run mode, the microcontroller can be clocked from several sources such as the internal precision oscillator or an external crystal oscillator. Either of these sources can then optionally drive an internal PLL to increase the effective frequency of the system up to 120 MHz. In this way, the run mode clock speed can be used to manage run mode current consumption.

The microcontroller also provides sleep and deep sleep modes and internal voltage adjustments to the flash and SRAM to further refine power consumption when the processor is not in use but peripherals must remain active. Each peripheral can be individually clock gated in these modes so that current consumption by unused peripherals is minimized. A wide variety of conditions from internal and external sources can trigger a return to run mode.

The lowest power setting of the microcontroller is hibernation, which requires a small amount of supporting external circuitry available on the Connected LaunchPad. The Connected LaunchPad can achieve microcontroller current consumption modes under 2 micro-Amps using hibernate VDD3ON mode. Hibernation with VDD3ON mode is not supported on this board. The Connected LaunchPad can be woken from hibernate by several triggers including the dedicated wake button, the reset button, an internal RTC timer and a subset of the device GPIO pins. The hibernation module provides a small area of internal SRAM that can preserve data through a hibernate cycle.

2.2.3 Clocking

The Connected LaunchPad uses a 25 MHz crystal (Y1) to drive the main TM4C1294NCPDTI internal clock circuit. Most software examples use the internal PLL to multiply this clock to higher frequencies up to 120 MHz for core and peripheral timing. The 25-MHz crystal is required when using the integrated Ethernet MAC and PHY.

The Hibernation module is clocked from an external 32.768-KHz crystal (Y3).

2.2.4 Reset

The RESET signal to the TM4C1294NCPDTI microcontroller connects to the RESET switch, BoosterPack connectors, Breadboard adapter and to the ICDI circuit for a debugger-controller reset.

External reset is asserted (active low) under the following conditions:

- Power-on reset (filtered by and R-C network)
- RESET switch is held down.
- By the ICDI circuit when instructed by the debugger (this capability is optional, and may not be supported by all debuggers)
- By an external circuit attached to the BoosterPack or Breadboard connectors.

2.3 Debug Interface

2.3.1 In-Circuit Debug Interface (ICDI)

The Connected LaunchPad comes with an on-board ICDI. The ICDI allows for the programming and debugging of the TM4C1294NCPDTI using LM Flash Programmer and/or any of the supported tool chains. Note that ICDI only supports JTAG debugging at this time. It is possible to use other JTAG emulators instead of the on board ICDI, by connecting to U6. When the ICDI detects an external debug adapter connection on the JTAG connector U6 and disables the ICDI outputs to allow the external debug adapter to drive the debug circuit. For more information, see [Section 2.3.2](#).

Debug out of the ICDI is possible by removing resistors R6, R7, R8, R10, R11, R15, R16 and R40 from the Connected LaunchPad and use the ICDI to drive JTAG signals out on U6 for the purpose of programming or debugging other boards. To restore the connection to the on-board TM4C1294NCPDTI microcontroller, install jumpers from the odd to even pins of X1 or re-install the resistors. Removal of R40 disables the detection of an attached external debugger. R40 must be installed to use an external debug adapter to program or debug the Connected LaunchPad.

2.3.2 External Debugger

The connector U6 is provided for the attachment of an external debug adapter such as the IAR J-Link or Keil ULINK. This connector follows the ARM standard 10-pin JTAG pinout. This interface can use either JTAG or SWD if supported by the external debug adapter.

2.3.3 Virtual COM Port

When plugged into a USB host, the ICDI enumerates as both a debugger and a virtual COM port. JP4 and JP5 control the selection of which UART from the TM4C1294NCPDTI is connected to the virtual COM port. In the default configuration, UART0 maps to the virtual COM port of the ICDI. In the CAN jumper configuration, UART2 maps to the virtual COM port of the ICDI.

Software Development

This chapter provides general information on software development as well as instructions for flash memory programming.

3.1 Software Description

The TivaWare software provides drivers for all of the peripheral devices supplied in the design. The Tiva C Series Peripheral Driver Library is used to operate the on-chip peripherals as part of TivaWare.

TivaWare includes a set of example applications that use the TivaWare Peripheral Driver Library. These applications demonstrate the capabilities of the TM4C1294NCPDTI microcontroller, as well as provide a starting point for the development of the final application for use on the Connected LaunchPad evaluation board. Example applications are also provided for the Connected LaunchPad when paired with selected BoosterPacks.

3.2 Source Code

The complete source code including the source code installation instructions are provided at <http://www.ti.com/tool/sw-tm4c>. The source code and binary files are installed in the TivaWare software tree.

3.3 Tool Options

The source code installation includes directories containing projects, makefiles, and binaries for the following tool-chains:

- Keil ARM RealView® Microcontroller Development System
- IAR Embedded Workbench for ARM
- Sourcery Codebench
- Generic GNU C Compiler
- Texas Instruments' Code Composer Studio™ IDE

Download evaluation versions of these tools from the [Tools & Software](#) section of www.ti.com/tiva. Due to code size restrictions, the evaluation tools may not build all example programs. A full license is necessary to re-build or debug all examples.

For detailed information on using the tools, see the documentation included in the tool chain installation or visit the website of the tools supplier.

3.4 Programming the Connected LaunchPad

The Connected LaunchPad software package includes pre-built binaries for each of the example applications. If you installed the TivaWare™ software to the default installation path of `C:\ti\TivaWare_C_Series_<version>`, you can find the example applications in `C:\ti\TivaWare_C_Series_<version>\examples\boards\ek-tm4c129xl`. The on-board ICDI is used with the LM Flash Programmer tool to program applications on the Connected LaunchPad.

Follow these steps to program example applications into the Connected LaunchPad evaluation board using the ICDI:

1. Install [LM Flash Programmer](#) on a PC running Microsoft Windows.
2. Place JP1 into the ICDI position on the Connected LaunchPad.
3. Connect the USB-A cable plug in to an available USB port on the PC and plug the Micro-B plug to the Debug USB port (U22) on the Connected LaunchPad.
4. Verify that LED D0 at the top of the board is illuminated.
5. Install Windows ICDI and Virtual COM Port drivers if prompted. Installation instructions can be found at <http://www.ti.com/lit/pdf/spmu287>.
6. Run the LM Flash Programmer application on the PC.
7. In the Configuration tap, use the Quick Set control to select “TM4C1294XL LaunchPad”.
8. Move to the Program tab and click the Browse button. Navigate to the example applications directory (the default location is `C:\ti\TivaWare_C_Series_<version>\examples\boards\ek-tm4c1294xl`)
9. Each example application has its own directory. Navigate to the example directory that you want to load and then into the sub-directory for one of the supported tool chains which contains the binary (*.bin) file. Select the binary file and click Open.
10. Set the Erase Method to Erase Necessary Pages, check the Verify After Program box, and check Reset MCU After Program. The example program starts execution once the verify process is complete.

References, PCB Layout, and Bill of Materials

4.1 References

In addition to this document the following references are available for download at www.ti.com.

- TivaWare for C Series (<http://www.ti.com/tool/sw-tm4c>)
- TivaWare Peripheral Driver Library Users' Guide (literature number [SPMU298](#))
- EK-TM4C1294XL Getting Started Guide (literature number [SPMZ858](#))
- LM Flash Programmer Tool (<http://www.ti.com/lmflashprogrammer>)
- TPS73733 Low-Dropout Regulator with Reverse Current Protection (<http://www.ti.com/product/tps79733>)
- Texas Instruments Code Composer Studio website (<http://www.ti.com/ccs>)
- Tiva C Series TM4C1294NCPDT Microcontroller Data Sheet (<http://www.ti.com/lit/gpn/tm4c1294ncpdt>)
- Build Your Own BoosterPack information regarding the BoosterPack standard (<http://www.ti.com/byob>)
- ICDI Driver Installation Guide (literature number [SPMU287](#))

Additional Support:

- Keil RealView MDK-ARM (<http://www.keil.com/arm/mdk.asp>)
- IAR Embedded Workbench for ARM (<http://iar.com/ewarm/>)
- Sourcery CodeBench development tools (<http://www.mentor.com/embedded-software/sourcery-tools/sourcery-codebench/overview>)
- Exosite (<http://ti.exosite.com>)

4.2 Component Locations

Figure 4-1 is a dimensioned drawing of the Connected LaunchPad. This figure shows the location of selected features of the board as well as the component locations.

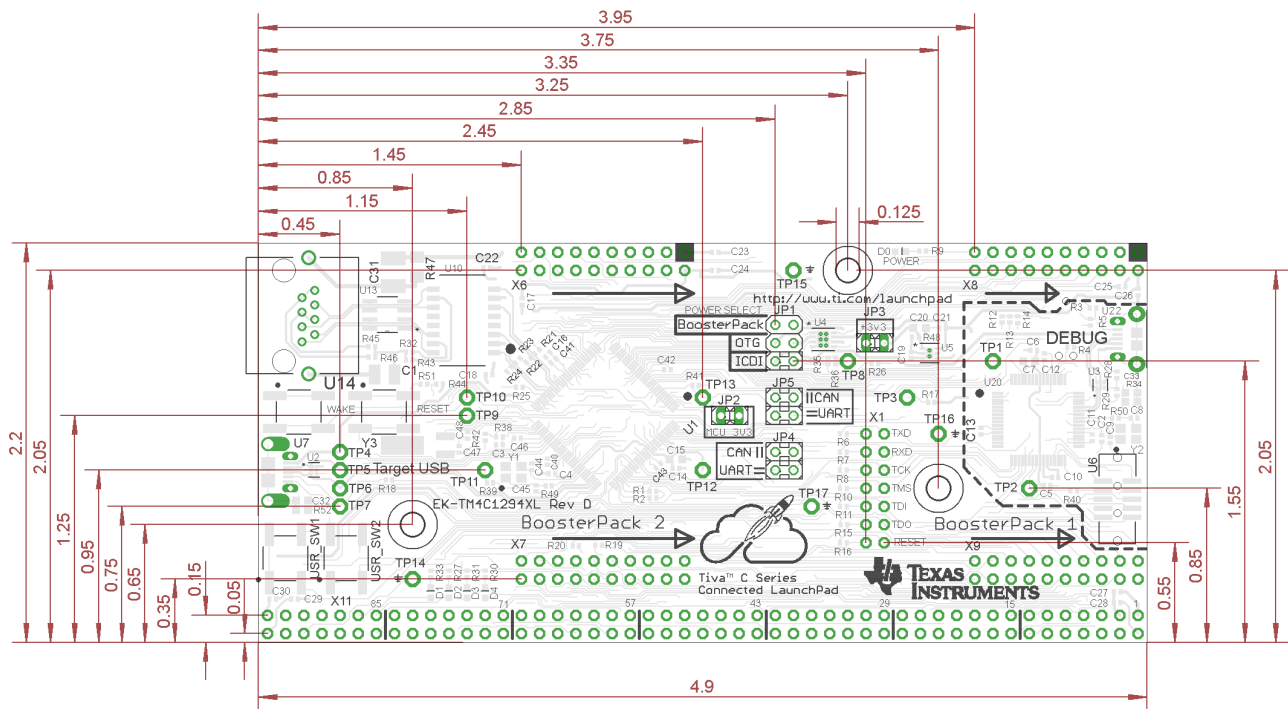

Figure 4-1. Connected LaunchPad Dimensions and Component Locations

4.3 Bill of Materials

Table 4-1 is the Connected LaunchPad bill of materials list.

Table 4-1. Connected LaunchPad Bill of Materials

Item	Ref	Qty	Description	Mfg	Part Number
1	C1	1	Capacitor, 1000pF, 2kV, 20%, X7R, 1210	Kemet	C1210C102MGRACTU
2	C3, C4, C5, C10, C11, C12, C13, C16, C17, C18, C19, C21, C22, C23, C24, C25, C26, C27, C28, C29, C30, C40, C41, C42, C43, C46	26	Capacitor, 0.1uF 16V, 10%,0402 X7R	Taiyo Yuden	EMK105B7104KV-F
3	C31	1	Capacitor, 4700pF, 2kV, 10%,X7R, 1812	AVX	1812GC472KAT1A
4	C32, C33	2	Capacitor, 3300pF, 50V, 10%, X7R, 0603	TDK	C1608X7R1H332K
5	C6, C14	2	Capacitor, 1uF, X5R, 10V, Low ESR, 0402	Johanson Dielectrics Inc	100R07X105KV4T
6	C7, C15, C20	3	Capacitor, 2.2uF, 16V, 10%, 0603, X5R	Murata	GRM188R61C225KE15D
7	C8, C9, C44, C45, C47, C48	6	Capacitor, 12pF, 50V, 5%, 0402, COG	Murata	GRM1555C1H120JZ01D
8	D0, D1, D2, D3, D4	5	Green LED 0603	Everlight	19-217/G7C-AL1M2B/3T
9	J1, J2, J3, J4, J5, J6, J7	7	Jumper, 0.100, Gold, Black, Open	3M	969102-0000-DA
				Kobiconn	151-8000-E
10	JP1	1	Header, 2x3, 0.100, T-Hole, Vertical Unshrouded, 0.230 Mate, gold	FCI	67996-206HLF
11	JP2, JP3	2	Header, 1x2, 0.100, T-Hole, Vertical Unshrouded, 0.220 Mate	3M	961102-6404-AR
				FCI	68001-102HLF
				Anyone	1x2-head
12	JP4, JP5	2	Header, 2x2, 0.100, T-Hole, Vertical Unshrouded, 0.230 Mate	FCI	67997-104HLF
				4UCON	00998
13	R1, R2, R3, R4, R5, R29, R35, R44	8	Resistor, 10k ohm, 1/10W, 5%, 0402 Thick Film	Yageo	RC0402FR-0710KL
14	R17, R26, R36	3	100k 5% 0402 resistor smd	Rohm	MCR01MRTJ104
15	R18, R51	2	Resistor 0402 100 ohm 5%	Rohm	MCR1MRTJ101
16	R23, R21, R22, R24	4	Resistor 49.9 ohm 0402. 1 %	Rohm	MCR01MRTF49R9
17	R25	1	Resistor 4.87k 1% 0402 smd	Rohm	MCR01MRTF4871
18	R28	1	Resistor, 5.6k ohm, 1/10W, 5%, 0402	Panasonic	ERJ-2GEJ562X
19	R32, R43, R45, R46	4	resistor 75 ohm 0402 5%	Rohm	MCR01MRTJ750
20	R34, R52	2	Resistor, 1M OH, 1/10W, 5% 0603 SMD	Panasonic	ERJ-3GEYJ105V
21	R38	1	Resistor, 51 ohm, 1/10W, 5%, 0402	Panasonic	ERJ-2GEJ510X

Table 4-1. Connected LaunchPad Bill of Materials (continued)

Item	Ref	Qty	Description	Mfg	Part Number
22	R42	1	Resistor, 1M Ohm, 1/10W, 5%, 0402	Rohm	MCR01MRTF1004
23	R47	1	RES 1M OHM 5% 1206 TF	Panasonic	ERJ-8GEYJ105V
24	R49, R50	2	Resistor, 2.0k ohm, 1/10W, 5%, 0402	Panasonic	ERJ-3GEYJ202V
25	R6, R7, R8, R10, R11, R15, R16, R19, R20, R39, R40, R41	12	Resistor, 0 ohm, 1/10W, 5%, 0402	Panasonic	ERJ-2GE0R00X
26	R9, R27, R30, R31, R33	5	Resistor, 330 ohm, 1/10W, 5%, 0402	Yageo	RC0402FR-07330RL
27	RESET, USR_SW1, USR_SW2, WAKE	4	Switch, Tact 6mm SMT, 160gf	Omron	B3S-1000
28	U1	1	Tiva, MCU TM4C1294NCPDT 128 QFP with Ethernet MAC + PHY	Texas Instruments	TM4C1294NCPDT
				Texas Instruments	XM4C1294NCPDT
29	U10	1	Transformer, ethernet, 1 to 1. SOIC 16	Pulse Electronics	HX1198FNL
30	U13	1	Diode, 8 chan, +/-15KV, ESD Protection Array, SO-8	Semtech	SLVU2.8-4.TBT
31	U14	1	Connector, RJ45 NO MAG, shielded THRU HOLE	TE Connectivity	1-406541-5
32	U2, U3	2	IC 4CH ESD SOLUTION W/CLAMP 6SON	Texas Instruments	TPD4S012DRYR
33	U20	1	Stellaris TIVA MCU TM4C123GH6PMI	Texas Instruments	TM4C123GH6PMI
34	U22	1	USB Micro B receptacle right angle with guides	FCI	10118194-0001LF
35	U4	1	Fault protected power switch, dual channel, 8-SON	Texas Instruments	TPS2052BDRBR
36	U5	1	3.3V LDO TI TPS73733DRV fixed out 5V in	Texas Instruments	TPS73733DRV
37	U6	1	Header 2x5, 0.050, SM, Vertical Shrouded	Samtec	SHF-105-01-S-D-SM
				Don Connex Electronics	C44-10BSA1-G
38	U7	1	USB Micro AB receptacle. Right angle with through guides	Hirose	ZX62D-AB-5P8
39	X6, X7, X8, X9	4	Header, 2x10, T-Hole Vertical unshrouded stacking	Samtec	SSW-110-23-S-D
				Major League Electronics	SSHQ-110-D-08-F-LF
40	Y1	1	Crystal 25 MHz 3.2 x 2.5 mm	NDK	nx3225ga-25.000m-std-crg-2
41	Y2	1	Crystal 16 MHz 3.2 x 2.5 mm 4 pin	NDK	NX3225GA-16.000M-STD-CRG-2
42	Y3	1	Crystal, 32.768 KHz Radial Can	Citizen Finetech Miyota	CMR200T-32.768KDZY-UT

Table 4-1. Connected LaunchPad Bill of Materials (continued)

Item	Ref	Qty	Description	Mfg	Part Number
PCB Do Not Populate List (Shown for information only)					
43	C2	1	Capacitor, 0.1uF 16V, 10%, 0402 X7R	Taiyo Yuden	EMK105B7104KV-F
44	H1, H4, H6	3	Screw, #4 x 0.625" Pan Head, Sheet Metal, Phillips/Slotted (for fan)	McMaster	90077A112
45	R12, R13, R14	3	Resistor, 5.6k ohm, 1/10W, 5%, 0402	Panasonic	ERJ-2GEJ562X
46	R48	1	Resistor 0402 1% 52.3k	Rohm	TRR01MZPF5232
47	TP1, TP2, TP3, TP4, TP5, TP6, TP7, TP8, TP9, TP10, TP11, TP12, TP13, TP14, TP15, TP16, TP17	17	Terminal, Test Point Miniature Loop, Red, T-Hole	Keystone	5000
48	X1	1	Header, 2x7, 0.100, T-Hole, Vertical, Unshrouded, 0.230 Mate	FCI	67997-114HLF
49	X11A	1	Valvano style bread board connect. Right Angle extended, 1 x 49 0.100 pitch.	Samtec	TSW-149-09-F-S-RE
50	X11B	1	valvano style breadboard header.	Samtec	TSW-149-08-F-S-RA

Schematic

This section contains the complete schematics for the Tiva C Series TM4C1294 Connected LaunchPad.

- Microcontroller, USB, Buttons, and LED's
- BoosterPack connectors
- Breadboard connector
- Ethernet and Ethernet LED's
- Power
- In-Circuit Debug Interface

convenience test points for ground

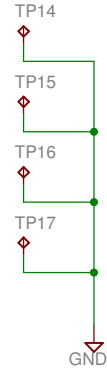

GPIO		U1G\$1	
PA0	P\$33	PA0	PB0
PA1	P\$34	PA1	PB1
PA2	P\$35	PA2	PB2
PA3	P\$36	PA3	PB3
PA4	P\$37	PA4	PB4
PA5	P\$38	PA5	PB5
PA6	P\$40	PA6	
PA7	P\$41	PA7	
		PC0	PD0
		PC1	PD1
		PC2	PD2
		PC3	PD3
		PC4	PD4
		PC5	PD5
		PC6	PD6
		PC7	PD7
		PE0	PF0
		PE1	PF1
		PE2	PF2
		PE3	PF3
		PE4	PF4
		PE5	
		PG0	PH0
		PG1	PH1
		PG1	PH2
		PG1	PH3
		PJ0	PK0
		PJ1	PK1
		PJ1	PK2
		PJ1	PK3
		PJ1	PK4
		PJ1	PK5
		PJ1	PK6
		PJ1	PK7
		PM0	PN0
		PM1	PN1
		PM2	PN2
		PM3	PN3
		PM4	PN4
		PM5	PN5
		PM6	
		PM7	
		PP0	PQ0
		PP1	PQ1
		PP2	PQ2
		PP3	PQ3
		PP4	PQ4
		PP5	

TM4C1294NCPDT

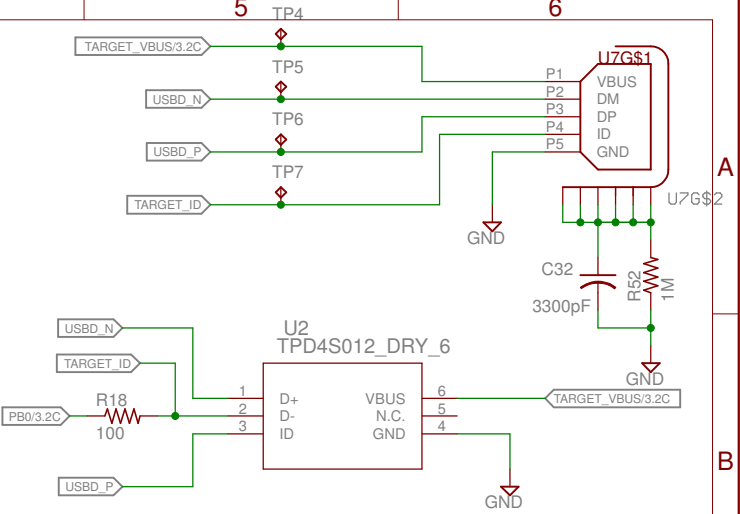

NOTE: TPD4S012 all protection circuits are identical. Connections chosen for simple routing.

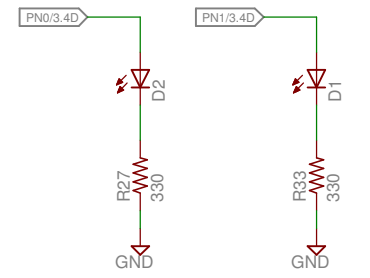

See PF0 and PF4 for additional LED's used for Ethernet or user application

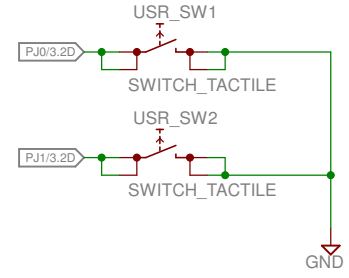

A

B

C

D

E

A

B

C

D

E

TITLE: EK-TM4C1294XL REV D	
Document Number:	REV:
Date: 1/24/2014 4:55:11 PM	Sheet: 1/6

1

2

3

4

5

6

A

A

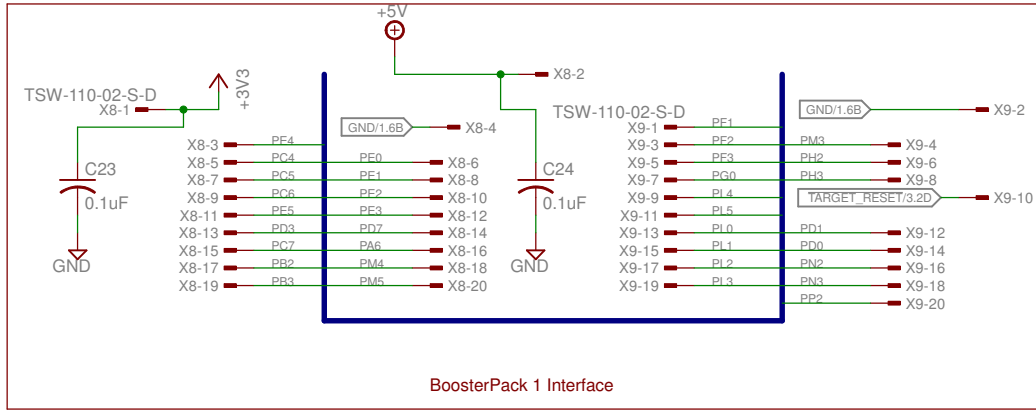

B

B

C

C

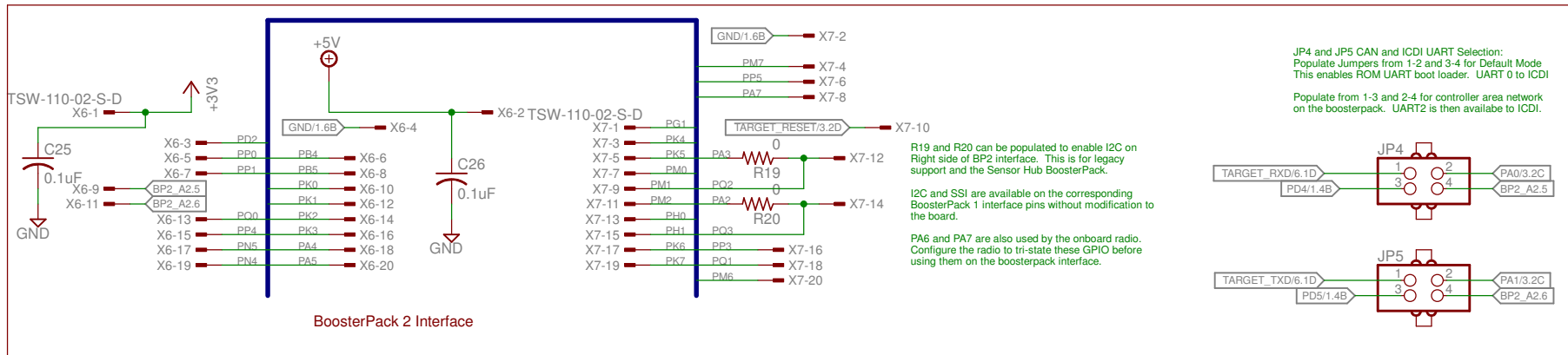

D

D

E

E

TITLE: EK-TM4C1294XL REV D	
Document Number:	REV:
Date: 1/24/2014 4:55:11 PM	Sheet: 2/6

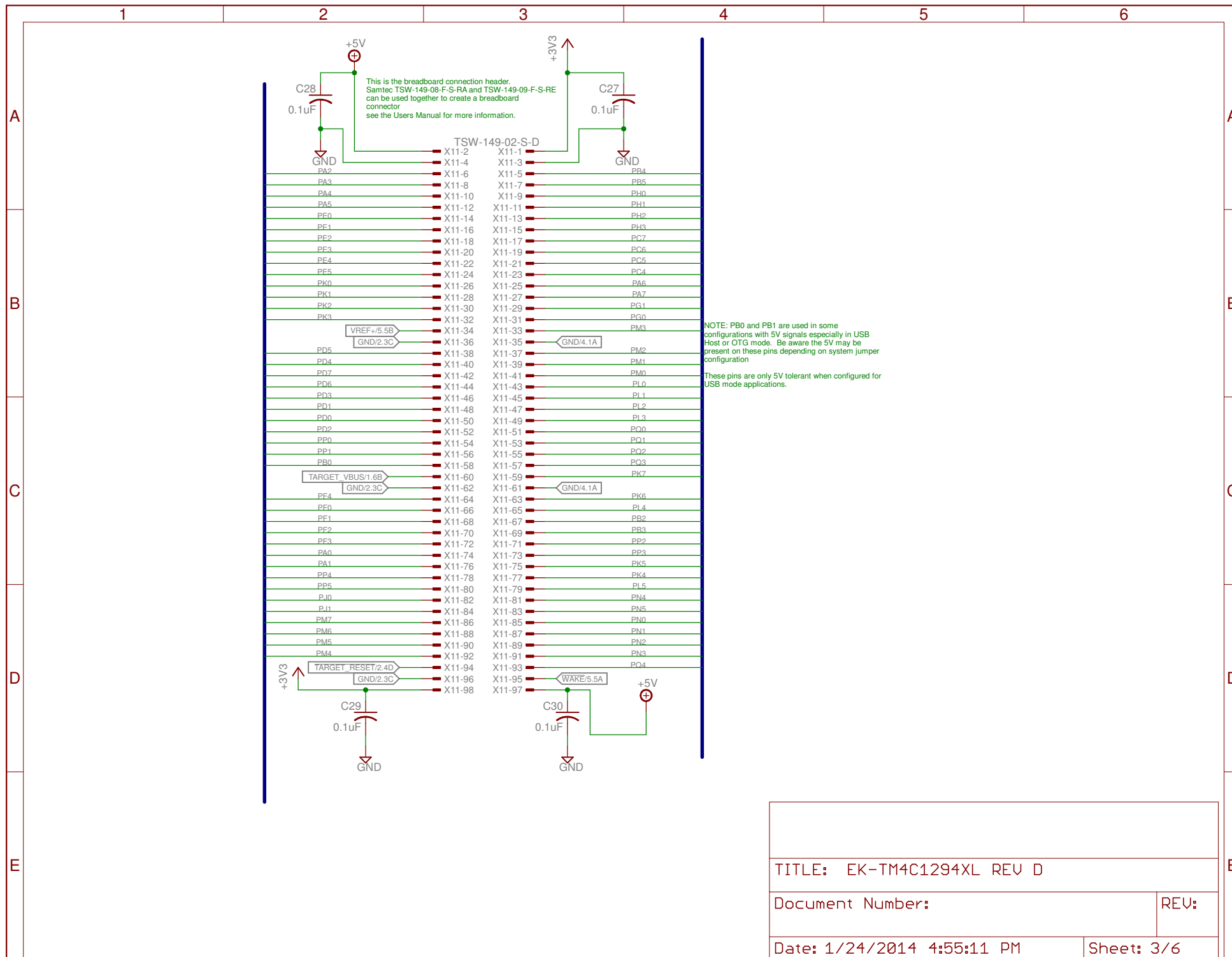

TITLE: EK-TM4C1294XL REV D

Document Number:

REV:

Date: 1/24/2014 4:55:11 PM

Sheet: 3/6

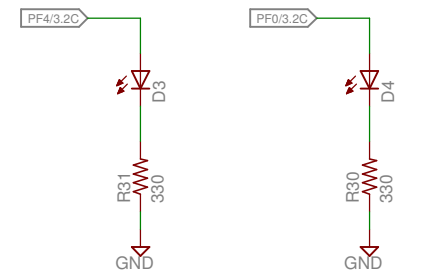
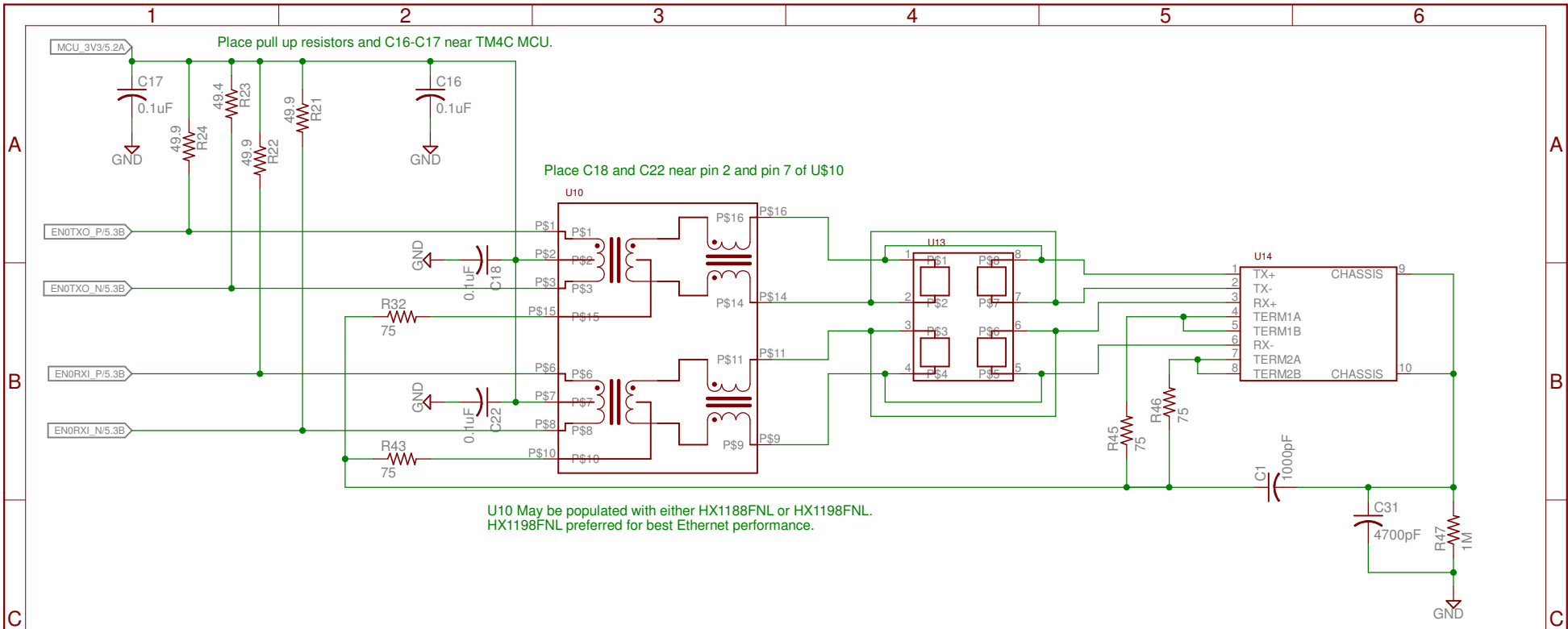

For Ethernet example Applications:
LED4 is default configured as Ethernet Link OK
LED3 is default configured as Ethernet TX/RX activity
User may re-configure these pins / LED's for any application usage.

TITLE: EK-TM4C1294XL REV D	
Document Number:	REV:
Date: 1/24/2014 4:55:11 PM	Sheet: 4/6

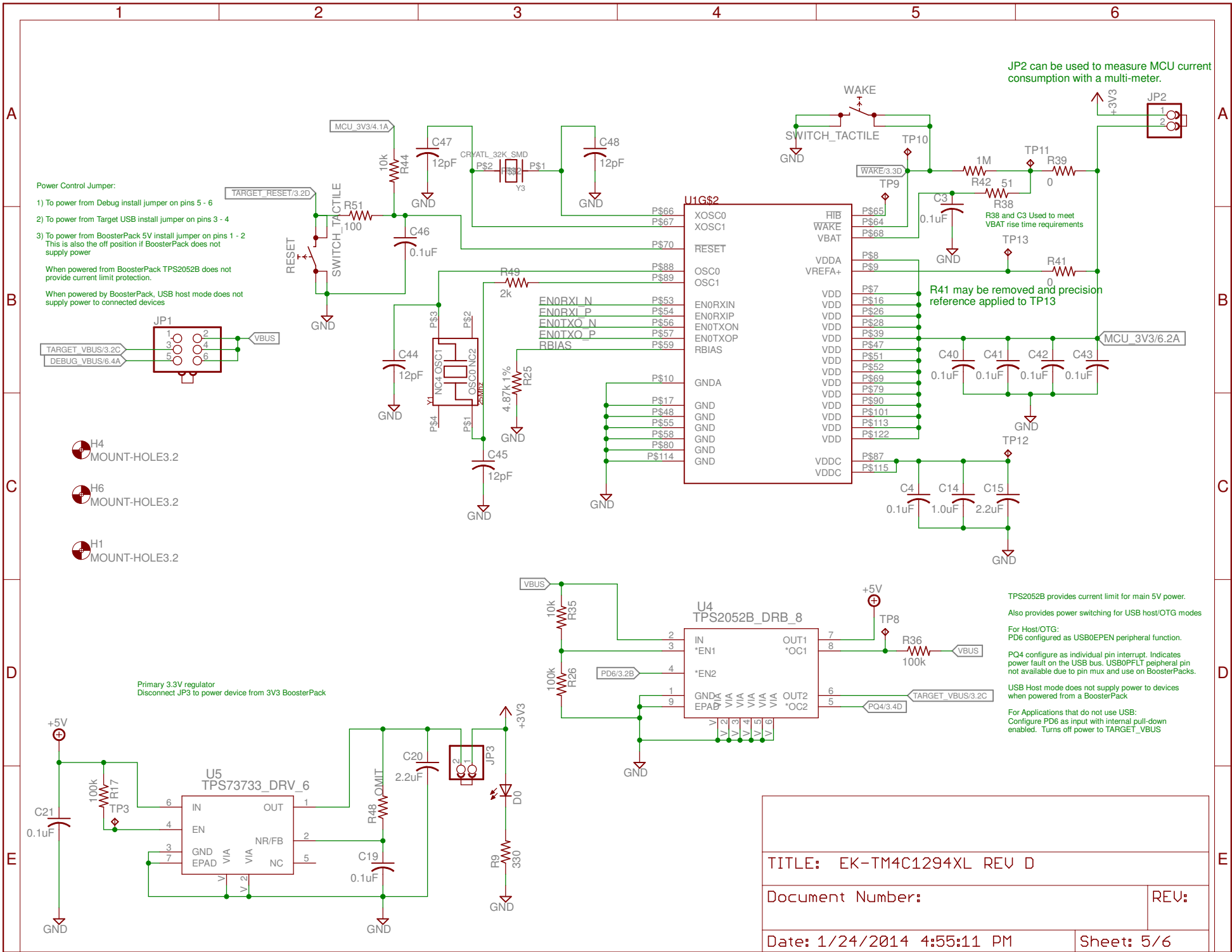

Power Control Jumper:

- 1) To power from Debug install jumper on pins 5 - 6
- 2) To power from Target USB install jumper on pins 3 - 4
- 3) To power from BoosterPack 5V install jumper on pins 1 - 2
This is also the off position if BoosterPack does not supply power

When powered from BoosterPack TPS2052B does not provide current limit protection.

When powered by BoosterPack, USB host mode does not supply power to connected devices

JP2 can be used to measure MCU current consumption with a multi-meter.

R38 and C3 Used to meet VBAT rise time requirements

R41 may be removed and precision reference applied to TP13

TPS2052B provides current limit for main 5V power. Also provides power switching for USB host/OTG modes

For Host/OTG: PD6 configured as USB0EPEN peripheral function.

PQ4 configure as individual pin interrupt. Indicates power fault on the USB bus. USB0PFLT peripheral pin not available due to pin mux and use on BoosterPacks.

USB Host mode does not supply power to devices when powered from a BoosterPack

For Applications that do not use USB: Configure PD6 as input with internal pull-down enabled. Turns off power to TARGET_VBUS

Primary 3.3V regulator
Disconnect JP3 to power device from 3V3 BoosterPack

TITLE: EK-TM4C1294XL REV D	
Document Number:	REV:
Date: 1/24/2014 4:55:11 PM	Sheet: 5/6

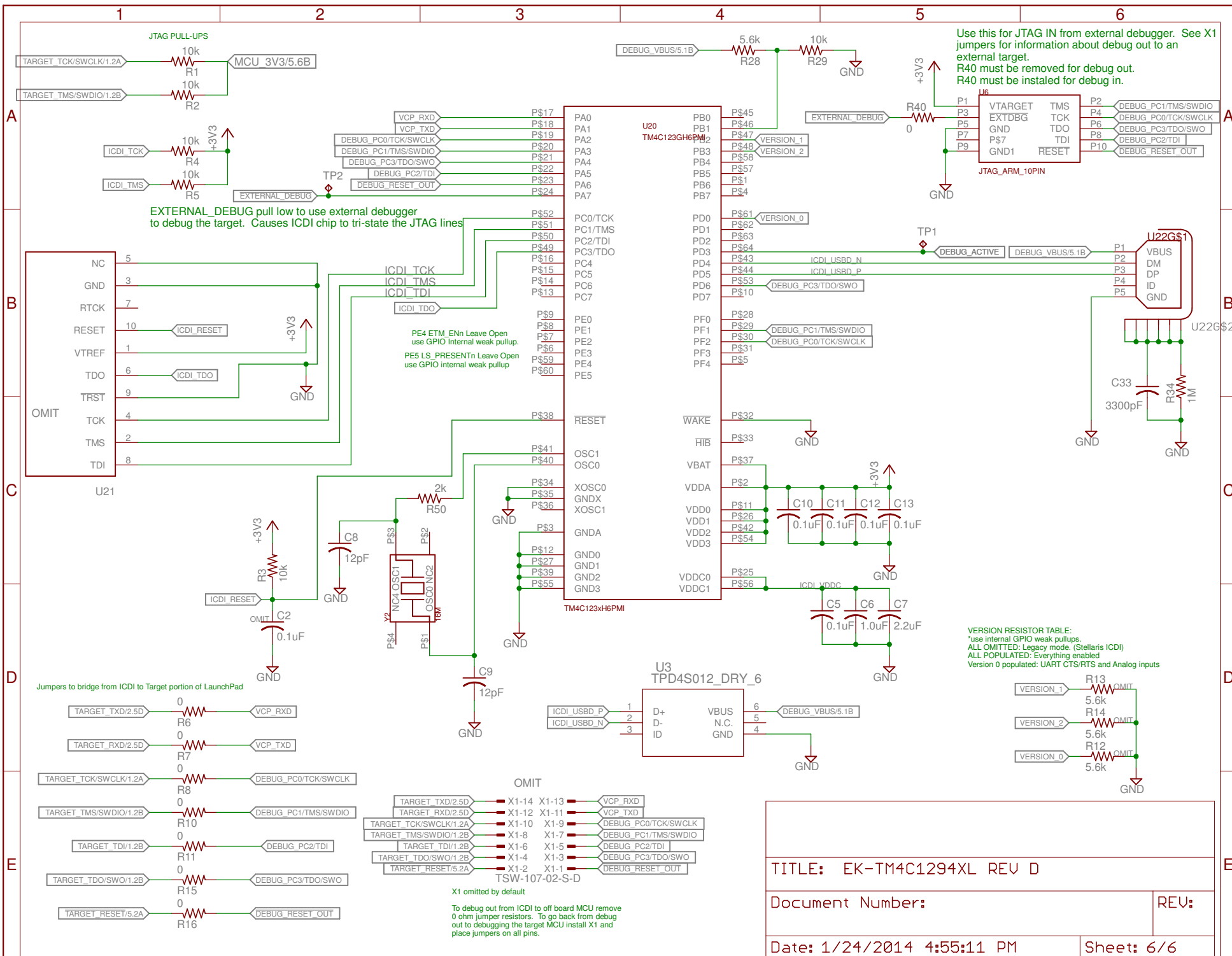

TITLE: EK-TM4C1294XL REV D

Document Number:

REV:

Date: 1/24/2014 4:55:11 PM

Sheet: 6/6

Revision History

Changes from B Revision (May 2015) to C Revision

Page

- GLOBAL: Updated/Changed all instances of "UART4" to "UART2"..... [4](#)
-

STANDARD TERMS FOR EVALUATION MODULES

1. *Delivery:* TI delivers TI evaluation boards, kits, or modules, including any accompanying demonstration software, components, and/or documentation which may be provided together or separately (collectively, an "EVM" or "EVMs") to the User ("User") in accordance with the terms set forth herein. User's acceptance of the EVM is expressly subject to the following terms.
 - 1.1 EVMs are intended solely for product or software developers for use in a research and development setting to facilitate feasibility evaluation, experimentation, or scientific analysis of TI semiconductor products. EVMs have no direct function and are not finished products. EVMs shall not be directly or indirectly assembled as a part or subassembly in any finished product. For clarification, any software or software tools provided with the EVM ("Software") shall not be subject to the terms and conditions set forth herein but rather shall be subject to the applicable terms that accompany such Software
 - 1.2 EVMs are not intended for consumer or household use. EVMs may not be sold, sublicensed, leased, rented, loaned, assigned, or otherwise distributed for commercial purposes by Users, in whole or in part, or used in any finished product or production system.
2. *Limited Warranty and Related Remedies/Disclaimers:*
 - 2.1 These terms do not apply to Software. The warranty, if any, for Software is covered in the applicable Software License Agreement.
 - 2.2 TI warrants that the TI EVM will conform to TI's published specifications for ninety (90) days after the date TI delivers such EVM to User. Notwithstanding the foregoing, TI shall not be liable for a nonconforming EVM if (a) the nonconformity was caused by neglect, misuse or mistreatment by an entity other than TI, including improper installation or testing, or for any EVMs that have been altered or modified in any way by an entity other than TI, (b) the nonconformity resulted from User's design, specifications or instructions for such EVMs or improper system design, or (c) User has not paid on time. Testing and other quality control techniques are used to the extent TI deems necessary. TI does not test all parameters of each EVM. User's claims against TI under this Section 2 are void if User fails to notify TI of any apparent defects in the EVMs within ten (10) business days after delivery, or of any hidden defects with ten (10) business days after the defect has been detected.
 - 2.3 TI's sole liability shall be at its option to repair or replace EVMs that fail to conform to the warranty set forth above, or credit User's account for such EVM. TI's liability under this warranty shall be limited to EVMs that are returned during the warranty period to the address designated by TI and that are determined by TI not to conform to such warranty. If TI elects to repair or replace such EVM, TI shall have a reasonable time to repair such EVM or provide replacements. Repaired EVMs shall be warranted for the remainder of the original warranty period. Replaced EVMs shall be warranted for a new full ninety (90) day warranty period.
3. *Regulatory Notices:*
 - 3.1 *United States*
 - 3.1.1 *Notice applicable to EVMs not FCC-Approved:*

FCC NOTICE: This kit is designed to allow product developers to evaluate electronic components, circuitry, or software associated with the kit to determine whether to incorporate such items in a finished product and software developers to write software applications for use with the end product. This kit is not a finished product and when assembled may not be resold or otherwise marketed unless all required FCC equipment authorizations are first obtained. Operation is subject to the condition that this product not cause harmful interference to licensed radio stations and that this product accept harmful interference. Unless the assembled kit is designed to operate under part 15, part 18 or part 95 of this chapter, the operator of the kit must operate under the authority of an FCC license holder or must secure an experimental authorization under part 5 of this chapter.
 - 3.1.2 *For EVMs annotated as FCC – FEDERAL COMMUNICATIONS COMMISSION Part 15 Compliant:*

CAUTION

This device complies with part 15 of the FCC Rules. Operation is subject to the following two conditions: (1) This device may not cause harmful interference, and (2) this device must accept any interference received, including interference that may cause undesired operation.

Changes or modifications not expressly approved by the party responsible for compliance could void the user's authority to operate the equipment.

FCC Interference Statement for Class A EVM devices

NOTE: This equipment has been tested and found to comply with the limits for a Class A digital device, pursuant to part 15 of the FCC Rules. These limits are designed to provide reasonable protection against harmful interference when the equipment is operated in a commercial environment. This equipment generates, uses, and can radiate radio frequency energy and, if not installed and used in accordance with the instruction manual, may cause harmful interference to radio communications. Operation of this equipment in a residential area is likely to cause harmful interference in which case the user will be required to correct the interference at his own expense.

FCC Interference Statement for Class B EVM devices

NOTE: This equipment has been tested and found to comply with the limits for a Class B digital device, pursuant to part 15 of the FCC Rules. These limits are designed to provide reasonable protection against harmful interference in a residential installation. This equipment generates, uses and can radiate radio frequency energy and, if not installed and used in accordance with the instructions, may cause harmful interference to radio communications. However, there is no guarantee that interference will not occur in a particular installation. If this equipment does cause harmful interference to radio or television reception, which can be determined by turning the equipment off and on, the user is encouraged to try to correct the interference by one or more of the following measures:

- Reorient or relocate the receiving antenna.
- Increase the separation between the equipment and receiver.
- Connect the equipment into an outlet on a circuit different from that to which the receiver is connected.
- Consult the dealer or an experienced radio/TV technician for help.

3.2 Canada

3.2.1 For EVMs issued with an Industry Canada Certificate of Conformance to RSS-210 or RSS-247

Concerning EVMs Including Radio Transmitters:

This device complies with Industry Canada license-exempt RSSs. Operation is subject to the following two conditions:

(1) this device may not cause interference, and (2) this device must accept any interference, including interference that may cause undesired operation of the device.

Concernant les EVMs avec appareils radio:

Le présent appareil est conforme aux CNR d'Industrie Canada applicables aux appareils radio exempts de licence. L'exploitation est autorisée aux deux conditions suivantes: (1) l'appareil ne doit pas produire de brouillage, et (2) l'utilisateur de l'appareil doit accepter tout brouillage radioélectrique subi, même si le brouillage est susceptible d'en compromettre le fonctionnement.

Concerning EVMs Including Detachable Antennas:

Under Industry Canada regulations, this radio transmitter may only operate using an antenna of a type and maximum (or lesser) gain approved for the transmitter by Industry Canada. To reduce potential radio interference to other users, the antenna type and its gain should be so chosen that the equivalent isotropically radiated power (e.i.r.p.) is not more than that necessary for successful communication. This radio transmitter has been approved by Industry Canada to operate with the antenna types listed in the user guide with the maximum permissible gain and required antenna impedance for each antenna type indicated. Antenna types not included in this list, having a gain greater than the maximum gain indicated for that type, are strictly prohibited for use with this device.

Concernant les EVMs avec antennes détachables

Conformément à la réglementation d'Industrie Canada, le présent émetteur radio peut fonctionner avec une antenne d'un type et d'un gain maximal (ou inférieur) approuvé pour l'émetteur par Industrie Canada. Dans le but de réduire les risques de brouillage radioélectrique à l'intention des autres utilisateurs, il faut choisir le type d'antenne et son gain de sorte que la puissance isotrope rayonnée équivalente (p.i.r.e.) ne dépasse pas l'intensité nécessaire à l'établissement d'une communication satisfaisante. Le présent émetteur radio a été approuvé par Industrie Canada pour fonctionner avec les types d'antenne énumérés dans le manuel d'usage et ayant un gain admissible maximal et l'impédance requise pour chaque type d'antenne. Les types d'antenne non inclus dans cette liste, ou dont le gain est supérieur au gain maximal indiqué, sont strictement interdits pour l'exploitation de l'émetteur.

3.3 Japan

3.3.1 *Notice for EVMs delivered in Japan:* Please see http://www.tij.co.jp/lstds/ti_ja/general/eStore/notice_01.page 日本国内に輸入される評価用キット、ボードについては、次のところをご覧ください。
http://www.tij.co.jp/lstds/ti_ja/general/eStore/notice_01.page

3.3.2 *Notice for Users of EVMs Considered "Radio Frequency Products" in Japan:* EVMs entering Japan may not be certified by TI as conforming to Technical Regulations of Radio Law of Japan.

If User uses EVMs in Japan, not certified to Technical Regulations of Radio Law of Japan, User is required to follow the instructions set forth by Radio Law of Japan, which includes, but is not limited to, the instructions below with respect to EVMs (which for the avoidance of doubt are stated strictly for convenience and should be verified by User):

1. Use EVMs in a shielded room or any other test facility as defined in the notification #173 issued by Ministry of Internal Affairs and Communications on March 28, 2006, based on Sub-section 1.1 of Article 6 of the Ministry's Rule for Enforcement of Radio Law of Japan,
2. Use EVMs only after User obtains the license of Test Radio Station as provided in Radio Law of Japan with respect to EVMs, or
3. Use of EVMs only after User obtains the Technical Regulations Conformity Certification as provided in Radio Law of Japan with respect to EVMs. Also, do not transfer EVMs, unless User gives the same notice above to the transferee. Please note that if User does not follow the instructions above, User will be subject to penalties of Radio Law of Japan.

【無線電波を送信する製品の開発キットをお使いになる際の注意事項】 開発キットの中には技術基準適合証明を受けていないものがあります。技術適合証明を受けていないものご使用に際しては、電波法遵守のため、以下のいずれかの措置を取っていただく必要がありますのでご注意ください。

1. 電波法施行規則第6条第1項第1号に基づく平成18年3月28日総務省告示第173号で定められた電波暗室等の試験設備でご使用いただく。
2. 実験局の免許を取得後ご使用いただく。
3. 技術基準適合証明を取得後ご使用いただく。

なお、本製品は、上記の「ご使用にあたっての注意」を譲渡先、移転先に通知しない限り、譲渡、移転できないものとします。

上記を遵守頂けない場合は、電波法の罰則が適用される可能性があることをご留意ください。日本テキサス・インスツルメンツ株式会社
東京都新宿区西新宿 6 丁目 2 4 番 1 号
西新宿三井ビル

3.3.3 *Notice for EVMs for Power Line Communication:* Please see http://www.tij.co.jp/lstds/ti_ja/general/eStore/notice_02.page
電力線搬送波通信についての開発キットをお使いになる際の注意事項については、次のところをご覧ください。 http://www.tij.co.jp/lstds/ti_ja/general/eStore/notice_02.page

3.4 *European Union*

3.4.1 *For EVMs subject to EU Directive 2014/30/EU (Electromagnetic Compatibility Directive):*

This is a class A product intended for use in environments other than domestic environments that are connected to a low-voltage power-supply network that supplies buildings used for domestic purposes. In a domestic environment this product may cause radio interference in which case the user may be required to take adequate measures.

4 *EVM Use Restrictions and Warnings:*

4.1 EVMS ARE NOT FOR USE IN FUNCTIONAL SAFETY AND/OR SAFETY CRITICAL EVALUATIONS, INCLUDING BUT NOT LIMITED TO EVALUATIONS OF LIFE SUPPORT APPLICATIONS.

4.2 User must read and apply the user guide and other available documentation provided by TI regarding the EVM prior to handling or using the EVM, including without limitation any warning or restriction notices. The notices contain important safety information related to, for example, temperatures and voltages.

4.3 *Safety-Related Warnings and Restrictions:*

4.3.1 User shall operate the EVM within TI's recommended specifications and environmental considerations stated in the user guide, other available documentation provided by TI, and any other applicable requirements and employ reasonable and customary safeguards. Exceeding the specified performance ratings and specifications (including but not limited to input and output voltage, current, power, and environmental ranges) for the EVM may cause personal injury or death, or property damage. If there are questions concerning performance ratings and specifications, User should contact a TI field representative prior to connecting interface electronics including input power and intended loads. Any loads applied outside of the specified output range may also result in unintended and/or inaccurate operation and/or possible permanent damage to the EVM and/or interface electronics. Please consult the EVM user guide prior to connecting any load to the EVM output. If there is uncertainty as to the load specification, please contact a TI field representative. During normal operation, even with the inputs and outputs kept within the specified allowable ranges, some circuit components may have elevated case temperatures. These components include but are not limited to linear regulators, switching transistors, pass transistors, current sense resistors, and heat sinks, which can be identified using the information in the associated documentation. When working with the EVM, please be aware that the EVM may become very warm.

4.3.2 EVMs are intended solely for use by technically qualified, professional electronics experts who are familiar with the dangers and application risks associated with handling electrical mechanical components, systems, and subsystems. User assumes all responsibility and liability for proper and safe handling and use of the EVM by User or its employees, affiliates, contractors or designees. User assumes all responsibility and liability to ensure that any interfaces (electronic and/or mechanical) between the EVM and any human body are designed with suitable isolation and means to safely limit accessible leakage currents to minimize the risk of electrical shock hazard. User assumes all responsibility and liability for any improper or unsafe handling or use of the EVM by User or its employees, affiliates, contractors or designees.

4.4 User assumes all responsibility and liability to determine whether the EVM is subject to any applicable international, federal, state, or local laws and regulations related to User's handling and use of the EVM and, if applicable, User assumes all responsibility and liability for compliance in all respects with such laws and regulations. User assumes all responsibility and liability for proper disposal and recycling of the EVM consistent with all applicable international, federal, state, and local requirements.

5. *Accuracy of Information:* To the extent TI provides information on the availability and function of EVMs, TI attempts to be as accurate as possible. However, TI does not warrant the accuracy of EVM descriptions, EVM availability or other information on its websites as accurate, complete, reliable, current, or error-free.

6. *Disclaimers:*

6.1 EXCEPT AS SET FORTH ABOVE, EVMS AND ANY MATERIALS PROVIDED WITH THE EVM (INCLUDING, BUT NOT LIMITED TO, REFERENCE DESIGNS AND THE DESIGN OF THE EVM ITSELF) ARE PROVIDED "AS IS" AND "WITH ALL FAULTS." TI DISCLAIMS ALL OTHER WARRANTIES, EXPRESS OR IMPLIED, REGARDING SUCH ITEMS, INCLUDING BUT NOT LIMITED TO ANY EPIDEMIC FAILURE WARRANTY OR IMPLIED WARRANTIES OF MERCHANTABILITY OR FITNESS FOR A PARTICULAR PURPOSE OR NON-INFRINGEMENT OF ANY THIRD PARTY PATENTS, COPYRIGHTS, TRADE SECRETS OR OTHER INTELLECTUAL PROPERTY RIGHTS.

6.2 EXCEPT FOR THE LIMITED RIGHT TO USE THE EVM SET FORTH HEREIN, NOTHING IN THESE TERMS SHALL BE CONSTRUED AS GRANTING OR CONFERRING ANY RIGHTS BY LICENSE, PATENT, OR ANY OTHER INDUSTRIAL OR INTELLECTUAL PROPERTY RIGHT OF TI, ITS SUPPLIERS/LICENSORS OR ANY OTHER THIRD PARTY, TO USE THE EVM IN ANY FINISHED END-USER OR READY-TO-USE FINAL PRODUCT, OR FOR ANY INVENTION, DISCOVERY OR IMPROVEMENT, REGARDLESS OF WHEN MADE, CONCEIVED OR ACQUIRED.

7. *USER'S INDEMNITY OBLIGATIONS AND REPRESENTATIONS.* USER WILL DEFEND, INDEMNIFY AND HOLD TI, ITS LICENSORS AND THEIR REPRESENTATIVES HARMLESS FROM AND AGAINST ANY AND ALL CLAIMS, DAMAGES, LOSSES, EXPENSES, COSTS AND LIABILITIES (COLLECTIVELY, "CLAIMS") ARISING OUT OF OR IN CONNECTION WITH ANY HANDLING OR USE OF THE EVM THAT IS NOT IN ACCORDANCE WITH THESE TERMS. THIS OBLIGATION SHALL APPLY WHETHER CLAIMS ARISE UNDER STATUTE, REGULATION, OR THE LAW OF TORT, CONTRACT OR ANY OTHER LEGAL THEORY, AND EVEN IF THE EVM FAILS TO PERFORM AS DESCRIBED OR EXPECTED.

8. *Limitations on Damages and Liability:*

8.1 *General Limitations.* IN NO EVENT SHALL TI BE LIABLE FOR ANY SPECIAL, COLLATERAL, INDIRECT, PUNITIVE, INCIDENTAL, CONSEQUENTIAL, OR EXEMPLARY DAMAGES IN CONNECTION WITH OR ARISING OUT OF THESE TERMS OR THE USE OF THE EVMS, REGARDLESS OF WHETHER TI HAS BEEN ADVISED OF THE POSSIBILITY OF SUCH DAMAGES. EXCLUDED DAMAGES INCLUDE, BUT ARE NOT LIMITED TO, COST OF REMOVAL OR REINSTALLATION, ANCILLARY COSTS TO THE PROCUREMENT OF SUBSTITUTE GOODS OR SERVICES, RETESTING, OUTSIDE COMPUTER TIME, LABOR COSTS, LOSS OF GOODWILL, LOSS OF PROFITS, LOSS OF SAVINGS, LOSS OF USE, LOSS OF DATA, OR BUSINESS INTERRUPTION. NO CLAIM, SUIT OR ACTION SHALL BE BROUGHT AGAINST TI MORE THAN TWELVE (12) MONTHS AFTER THE EVENT THAT GAVE RISE TO THE CAUSE OF ACTION HAS OCCURRED.

8.2 *Specific Limitations.* IN NO EVENT SHALL TI'S AGGREGATE LIABILITY FROM ANY USE OF AN EVM PROVIDED HEREUNDER, INCLUDING FROM ANY WARRANTY, INDEMNITY OR OTHER OBLIGATION ARISING OUT OF OR IN CONNECTION WITH THESE TERMS, EXCEED THE TOTAL AMOUNT PAID TO TI BY USER FOR THE PARTICULAR EVM(S) AT ISSUE DURING THE PRIOR TWELVE (12) MONTHS WITH RESPECT TO WHICH LOSSES OR DAMAGES ARE CLAIMED. THE EXISTENCE OF MORE THAN ONE CLAIM SHALL NOT ENLARGE OR EXTEND THIS LIMIT.

9. *Return Policy.* Except as otherwise provided, TI does not offer any refunds, returns, or exchanges. Furthermore, no return of EVM(s) will be accepted if the package has been opened and no return of the EVM(s) will be accepted if they are damaged or otherwise not in a resalable condition. If User feels it has been incorrectly charged for the EVM(s) it ordered or that delivery violates the applicable order, User should contact TI. All refunds will be made in full within thirty (30) working days from the return of the components(s), excluding any postage or packaging costs.

10. *Governing Law:* These terms and conditions shall be governed by and interpreted in accordance with the laws of the State of Texas, without reference to conflict-of-laws principles. User agrees that non-exclusive jurisdiction for any dispute arising out of or relating to these terms and conditions lies within courts located in the State of Texas and consents to venue in Dallas County, Texas. Notwithstanding the foregoing, any judgment may be enforced in any United States or foreign court, and TI may seek injunctive relief in any United States or foreign court.

IMPORTANT NOTICE FOR TI DESIGN INFORMATION AND RESOURCES

Texas Instruments Incorporated ("TI") technical, application or other design advice, services or information, including, but not limited to, reference designs and materials relating to evaluation modules, (collectively, "TI Resources") are intended to assist designers who are developing applications that incorporate TI products; by downloading, accessing or using any particular TI Resource in any way, you (individually or, if you are acting on behalf of a company, your company) agree to use it solely for this purpose and subject to the terms of this Notice.

TI's provision of TI Resources does not expand or otherwise alter TI's applicable published warranties or warranty disclaimers for TI products, and no additional obligations or liabilities arise from TI providing such TI Resources. TI reserves the right to make corrections, enhancements, improvements and other changes to its TI Resources.

You understand and agree that you remain responsible for using your independent analysis, evaluation and judgment in designing your applications and that you have full and exclusive responsibility to assure the safety of your applications and compliance of your applications (and of all TI products used in or for your applications) with all applicable regulations, laws and other applicable requirements. You represent that, with respect to your applications, you have all the necessary expertise to create and implement safeguards that (1) anticipate dangerous consequences of failures, (2) monitor failures and their consequences, and (3) lessen the likelihood of failures that might cause harm and take appropriate actions. You agree that prior to using or distributing any applications that include TI products, you will thoroughly test such applications and the functionality of such TI products as used in such applications. TI has not conducted any testing other than that specifically described in the published documentation for a particular TI Resource.

You are authorized to use, copy and modify any individual TI Resource only in connection with the development of applications that include the TI product(s) identified in such TI Resource. NO OTHER LICENSE, EXPRESS OR IMPLIED, BY ESTOPPEL OR OTHERWISE TO ANY OTHER TI INTELLECTUAL PROPERTY RIGHT, AND NO LICENSE TO ANY TECHNOLOGY OR INTELLECTUAL PROPERTY RIGHT OF TI OR ANY THIRD PARTY IS GRANTED HEREIN, including but not limited to any patent right, copyright, mask work right, or other intellectual property right relating to any combination, machine, or process in which TI products or services are used. Information regarding or referencing third-party products or services does not constitute a license to use such products or services, or a warranty or endorsement thereof. Use of TI Resources may require a license from a third party under the patents or other intellectual property of the third party, or a license from TI under the patents or other intellectual property of TI.

TI RESOURCES ARE PROVIDED "AS IS" AND WITH ALL FAULTS. TI DISCLAIMS ALL OTHER WARRANTIES OR REPRESENTATIONS, EXPRESS OR IMPLIED, REGARDING TI RESOURCES OR USE THEREOF, INCLUDING BUT NOT LIMITED TO ACCURACY OR COMPLETENESS, TITLE, ANY EPIDEMIC FAILURE WARRANTY AND ANY IMPLIED WARRANTIES OF MERCHANTABILITY, FITNESS FOR A PARTICULAR PURPOSE, AND NON-INFRINGEMENT OF ANY THIRD PARTY INTELLECTUAL PROPERTY RIGHTS.

TI SHALL NOT BE LIABLE FOR AND SHALL NOT DEFEND OR INDEMNIFY YOU AGAINST ANY CLAIM, INCLUDING BUT NOT LIMITED TO ANY INFRINGEMENT CLAIM THAT RELATES TO OR IS BASED ON ANY COMBINATION OF PRODUCTS EVEN IF DESCRIBED IN TI RESOURCES OR OTHERWISE. IN NO EVENT SHALL TI BE LIABLE FOR ANY ACTUAL, DIRECT, SPECIAL, COLLATERAL, INDIRECT, PUNITIVE, INCIDENTAL, CONSEQUENTIAL OR EXEMPLARY DAMAGES IN CONNECTION WITH OR ARISING OUT OF TI RESOURCES OR USE THEREOF, AND REGARDLESS OF WHETHER TI HAS BEEN ADVISED OF THE POSSIBILITY OF SUCH DAMAGES.

You agree to fully indemnify TI and its representatives against any damages, costs, losses, and/or liabilities arising out of your non-compliance with the terms and provisions of this Notice.

This Notice applies to TI Resources. Additional terms apply to the use and purchase of certain types of materials, TI products and services. These include; without limitation, TI's standard terms for semiconductor products (<http://www.ti.com/sc/docs/stdterms.htm>), [evaluation modules](#), and [samples](http://www.ti.com/sc/docs/sampterm.htm) (<http://www.ti.com/sc/docs/sampterm.htm>).

Mailing Address: Texas Instruments, Post Office Box 655303, Dallas, Texas 75265
Copyright © 2017, Texas Instruments Incorporated