

TPS1HA08-Q1, 40-V, 8-mΩ Single-Channel Smart High-Side Switch

1 Features

- Single-Channel Smart High-Side Switch with 8-mΩ R_{ON} ($T_J = 25^\circ\text{C}$)
- AEC Q-100 Qualified for Automotive Applications:
 - Device Temperature Grade 1: -40°C to $+125^\circ\text{C}$ Ambient Operating Temperature Range
 - Withstands 40-V Load Dump
- Improve Reliability Through Selectable Current Limiting
 - Current Limit Set-point at 20 A or 80 A
 - Overcurrent Response of Current Clamping or Instant Shutdown
- Robust Integrated Output Protection:
 - Integrated Thermal Protection
 - Protection Against Short to Ground/Battery
 - Automatic Switch-On During Reverse Battery
 - Automatic Shut Off if Loss of Battery/Ground Occurs
 - Integrated Output Clamp to Demagnetize Inductive Loads
 - Configurable Fault Handling
- Analog Sense Output Can Be Configured to Accurately Measure:
 - Load Current
 - Supply Voltage
 - Device Temperature
- Provides FLT Indication Back to MCU
 - Detection of Open Load and Short-to-Battery

2 Applications

- Body Control Modules
- Incandescent and LED Lighting
- Heating Elements:
 - Seat Heaters
 - Glow Plug
 - Tank Heaters
- Transmission Control Unit
- Climate Control
- Infotainment Display
- ADAS Modules

3 Description

The TPS1HA08-Q1 device is a single-channel smart high-side switch intended for use with 12-V automotive systems. The device integrates robust protection and diagnostic features to ensure output port protection even during harmful events like short circuits. The device protects against faults through a reliable current limit, which, depending on device variant, is available at both 80 A and 20 A and can be configured to react to an overcurrent event by either instantly turning the switch off or by regulating the output current at the set point. The high current limit option allows for usage in loads that require large transient currents, while the low current limit option provides improved protection for loads that do not require high peak current.

The TPS1HA08-Q1 also provides a high accuracy analog current sense that allows for improved diagnostics when driving loads. By reporting load current, device temperature, and supply voltage to a system MCU, the device enables predictive maintenance and load diagnostics that lengthen the system lifetime.

The TPS1HA08-Q1 is available in a small 16-pin HTSSOP package which allows for reduced PCB footprint.

Device Information⁽¹⁾

PART NUMBER	PACKAGE	BODY SIZE (NOM)
TPS1HA08-Q1	HTSSOP (16)	5.00 mm x 4.40 mm

(1) For all available packages, see the orderable addendum at the end of the data sheet.

Simplified Schematic

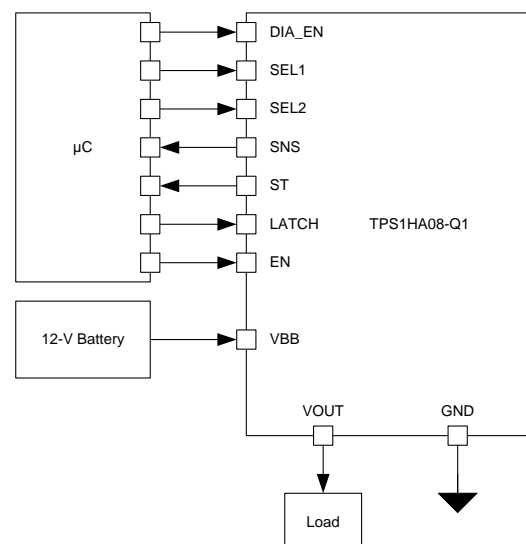

Table of Contents

1 Features	1	9.1 Overview	20
2 Applications	1	9.2 Functional Block Diagram	21
3 Description	1	9.3 Feature Description	22
4 Revision History	2	9.4 Device Functional Modes	37
5 Device Comparison Table	3	10 Application and Implementation	39
6 Pin Configuration and Functions	4	10.1 Application Information	39
6.1 Recommended Connections for Unused Pins	5	10.2 Typical Application	42
7 Specifications	6	11 Power Supply Recommendations	46
7.1 Absolute Maximum Ratings	6	12 Layout	47
7.2 ESD Ratings	6	12.1 Layout Guidelines	47
7.3 Recommended Operating Conditions	6	12.2 Layout Example	47
7.4 Thermal Information	7	13 Device and Documentation Support	48
7.5 Electrical Characteristics	7	13.1 Device Support	48
7.6 Switching Characteristics	9	13.2 Community Resources	48
7.7 SNS Timing Characteristics	10	13.3 Trademarks	48
7.8 Typical Characteristics	13	13.4 Electrostatic Discharge Caution	48
8 Parameter Measurement Information	19	13.5 Glossary	48
9 Detailed Description	20	14 Mechanical, Packaging, and Orderable Information	48

4 Revision History

Changes from Original (September 2017) to Revision A	Page
• Changed from Advance Information to Production Data	1

5 Device Comparison Table

Device Version	Full Device Number	Current Limit (I_{CL})	Overcurrent Behavior	Watchdog Feature
A	TPS1HA08A-Q1	20 A	Disable Switch Immediately	Disabled
B ⁽¹⁾	TPS1HA08B-Q1	80 A	Disable Switch Immediately	Disabled
C ⁽¹⁾	TPS1HA08C-Q1	20 A	Clamp Current at I_{CL} until Thermal Shutdown	Disabled
D ⁽¹⁾	TPS1HA08D-Q1	80 A	Clamp Current at I_{CL} until Thermal Shutdown	Disabled
E ⁽¹⁾	TPS1HA08E-Q1	20 A	Disable Switch Immediately	Enabled

(1) Product Preview, Contact TI factory for more information.

6 Pin Configuration and Functions

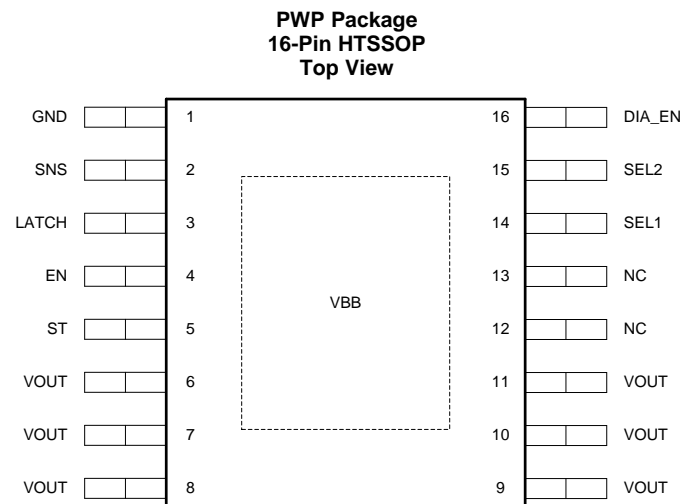

Pin Functions

PIN		I/O	DESCRIPTION
NO.	NAME		
1	GND	—	Device ground
2	SNS	O	Sense output
3	LATCH	I	Sets fault handling behavior (latched or auto-retry)
4	EN	I	Switch control input, active high
5	\overline{ST}	O	Switch diagnostic feedback, active low
6, 7, 8, 9, 10, 11	VOUT	O	Switch output
12	NC	--	No Connect
13	NC	--	No Connect
14	SEL1	I	Diagnostics Select 1
15	SEL2	I	Diagnostics Select 2
16	DIA_EN	I	Dagnostic enable, active high
Exposed pad	VBB	I	Power supply input

6.1 Recommended Connections for Unused Pins

The TPS1HA08-Q1 device is designed to provide an enhanced set of diagnostic and protection features. However, if the system design only allows for a limited number of I/O connections, some pins may be considered as optional.

Table 1. Connections for Optional Pins

PIN NAME	CONNECTION IF NOT USED	IMPACT IF NOT USED
SNS	Ground through 1 k Ω resistor	Analog sense is not available.
LATCH	Float or ground through R _{PROT} resistor	With LATCH unused, the device will auto-retry after a fault. If latched behavior is desired it is possible to use one microcontroller output to control the latch function of several high-side channels.
\overline{ST}	Float	All faults are indicated by the analog SNS pin. The \overline{ST} pin provides the additional benefits: <ul style="list-style-type: none"> • Provide fault indication when DIA_EN = 0 • Provide fault indication regardless of SELx pin conditions • Provide fault indication to a simple digital I/O (rather than ADC or comparator used with the SNS signal)
SEL1	Float or ground through R _{PROT} resistor	SEL1 selects between the V _{BB} and T _J sensing features. With SEL1 unused, only load diagnostics are available.
SEL2	Ground through R _{PROT} resistor	With SEL2 = 0 V, V _{BB} measurement diagnostics are not available.
DIA_EN	Float or ground through R _{PROT} resistor	With DIA_EN unused, analog sense, open-load and short-to-battery diagnostics are not available.

R_{PROT} is used to protect the pins from excess current flow during reverse battery conditions, for more information please see the section on [Reverse Battery](#) protection.

7 Specifications

7.1 Absolute Maximum Ratings

 over operating free-air temperature range (unless otherwise noted)⁽¹⁾

		MIN	MAX	UNIT	
V _{BB}	Maximum continuous supply voltage		36	V	
V _{LD}	Load dump voltage	ISO16750-2:2010(E)	40	V	
V _{Rev}	Reverse battery voltage	-18		V	
V _{EN}	Enable pin voltage	-1	7	V	
V _{LATCH}	LATCH pin voltage	-1	7	V	
V _{ST}	Status pin voltage	-1	7 ⁽²⁾	V	
V _{DIA_EN}	Diagnostic Enable pin voltage	-1	7	V	
V _{SNS}	Sense pin voltage	-1	7	V	
V _{SEL1} , V _{SEL2}	Select pin voltage	-1	7	V	
I _{GND}	Reverse ground current	V _{BB} < 0 V	-50	mA	
E _{TOFF}	Energy dissipation during turn-off	Single pulse, L _{OUT} = 5 mH, T _A = 125°C	95	mJ	
		Repetitive pulse, 10 Hz, L _{OUT} = 5 mH, T _A = 125°C	56	mJ	
T _J	Maximum junction temperature		150	°C	
T _{stg}	Storage temperature		-65	150	°C

- (1) Stresses beyond those listed under *Absolute Maximum Ratings* may cause permanent damage to the device. These are stress ratings only, which do not imply functional operation of the device at these or any other conditions beyond those indicated under *Recommended Operating Conditions*. Exposure to absolute-maximum-rated conditions for extended periods may affect device reliability.
- (2) These pins are adjacent to pins that will handle high-voltages. In the event of a pin-to-pin short, there will not be device damage.

7.2 ESD Ratings

				VALUE	UNIT
V _(ESD)	Electrostatic discharge	Human-body model (HBM), per AEC Q100-002 ⁽¹⁾	All pins except exposed pad and pins 6 to 11	±2000	V
			Exposed pad and pins 6 to 11	±4000	
		Charged-device model (CDM), per AEC Q100-011	All pins	±750	

- (1) AEC Q100-002 indicates that HBM stressing shall be in accordance with the ANSI/ESDA/JEDEC JS-001 specification.

7.3 Recommended Operating Conditions

over operating free-air temperature range (unless otherwise noted)

		MIN	MAX	UNIT	
V _{BB}	Nominal supply voltage	8	18	V	
V _{BB}	Extended operating range ⁽¹⁾	3	28	V	
V _{EN}	Enable voltage	-1	5.5	V	
V _{LATCH}	LATCH voltage	-1	5.5	V	
V _{DIA_EN}	Diagnostic enable voltage	-1	5.5	V	
V _{SEL1} , V _{SEL2}	Select voltage	-1	5.5	V	
V _{ST}	Status voltage	0	5.5	V	
V _{SNS}	Sense voltage	-1	V _{SNSclamp}	V	
I _{MAX}	Continuous load current	T _A = 70°C	0	10	A
T _A	Operating free-air temperature	-40	125	°C	

- (1) Device will function within extended operating range, however some parametric values might not apply

7.4 Thermal Information

THERMAL METRIC ⁽¹⁾ (2)		TPS1HA08-Q1	
		PWP (HTSSOP)	
		16 PINS	
			UNIT
$R_{\theta JA}$	Junction-to-ambient thermal resistance	32.8	°C/W
$R_{\theta JC(top)}$	Junction-to-case (top) thermal resistance	30.7	°C/W
$R_{\theta JB}$	Junction-to-board thermal resistance	9.3	°C/W
Ψ_{JT}	Junction-to-top characterization parameter	2.6	°C/W
Ψ_{JB}	Junction-to-board characterization parameter	9.4	°C/W
$R_{\theta JC(bot)}$	Junction-to-case (bottom) thermal resistance	1.0	°C/W

(1) For more information about traditional and new thermal metrics, see the [Semiconductor and IC Package Thermal Metrics](#) application report.

(2) The thermal parameters are based on a 4-layer PCB according to the JESD51-5 and JESD51-7 standards.

7.5 Electrical Characteristics

$V_{BB} = 8\text{ V to }18\text{ V}$, $T_J = -40^\circ\text{C to }150^\circ\text{C}$ (unless otherwise noted)

PARAMETER		TEST CONDITIONS	MIN	TYP	MAX	UNIT
INPUT VOLTAGE AND CURRENT						
V_{Clamp}	V_{DS} clamp voltage		40		58	V
V_{UVLOF}	V_{BB} undervoltage lockout falling			2.5	3	V
V_{UVLOR}	V_{BB} undervoltage lockout rising			2.5	3	V
I_{SB}	Standby current (includes MOSFET leakage)	$V_{BB} = 13.5\text{ V}$, $T_J = 25^\circ\text{C}$ $V_{EN} = V_{DIA_EN} = 0\text{ V}$, $V_{OUT} = 0\text{ V}$			0.5	μA
		$V_{BB} = 13.5\text{ V}$, $T_J = 85^\circ\text{C}$ $V_{EN} = V_{DIA_EN} = 0\text{ V}$, $V_{OUT} = 0\text{ V}$			0.5	μA
		$V_{BB} = 13.5\text{ V}$, $T_J = 125^\circ\text{C}$, $V_{EN} = V_{DIA_EN} = 0\text{ V}$, $V_{OUT} = 0\text{ V}$			3	μA
$I_{OUT(standby)}$	Output leakage current	$V_{BB} = 13.5\text{ V}$, $T_J = 25^\circ\text{C}$ $V_{EN} = V_{DIA_EN} = 0\text{ V}$, $V_{OUT} = 0\text{ V}$		0.01	0.5	μA
		$V_{BB} = 13.5\text{ V}$, $T_J = 125^\circ\text{C}$ $V_{EN} = V_{DIA_EN} = 0\text{ V}$, $V_{OUT} = 0\text{ V}$			3	μA
I_{DIA}	Current consumption in diagnostic mode	$V_{BB} = 13.5\text{ V}$, $I_{SNS} = 0\text{ mA}$ $V_{EN} = 0\text{ V}$, $V_{DIA_EN} = 5\text{ V}$, $V_{OUT} = 0\text{ V}$		3	6	mA
I_Q	Quiescent current	$V_{BB} = 13.5\text{ V}$ $V_{EN} = V_{DIA_EN} = 5\text{ V}$, $I_{OUT} = 0\text{ A}$, $V_{SELX} = 0\text{ V}$		3	6	mA
t_{STBY}	Standby mode delay time	$V_{EN} = V_{DIA_EN} = 0\text{ V}$ to Standby		20		ms
R_{ON} CHARACTERISTICS						
R_{ON}	On-resistance Includes MOSFET and package	$T_J = 25^\circ\text{C}$, $6\text{ V} \leq V_{BB} \leq 28\text{ V}$		8		m Ω
		$T_J = 150^\circ\text{C}$, $6\text{ V} \leq V_{BB} \leq 28\text{ V}$			20	m Ω
		$T_J = 25^\circ\text{C}$, $3\text{ V} \leq V_{BB} \leq 6\text{ V}$			15	m Ω
$R_{ON(REV)}$	On-resistance during reverse polarity	$T_J = 25^\circ\text{C}$, $-18\text{ V} \leq V_{BB} \leq -8\text{ V}$		8		m Ω
		$T_J = 105^\circ\text{C}$, $-18\text{ V} \leq V_{BB} \leq -8\text{ V}$			20	m Ω
CURRENT SENSE CHARACTERISTICS						
K_{SNS}	Current sense ratio I_{OUT} / I_{SNS}			4600		

Electrical Characteristics (continued)
 $V_{BB} = 8\text{ V to }18\text{ V}$, $T_J = -40^\circ\text{C to }150^\circ\text{C}$ (unless otherwise noted)

PARAMETER		TEST CONDITIONS		MIN	TYP	MAX	UNIT
I_{SNSI}	Current sense current and current sense accuracy	$V_{EN} = V_{DIA_EN} = 5\text{ V}$, $V_{SEL1} = V_{SEL2} = 0\text{ V}$	$I_{OUT} = 20\text{ A}$		4.35		mA
					-5	5	%
			$I_{OUT} = 8\text{ A}$		1.74		mA
					-5	5	%
			$I_{OUT} = 3\text{ A}$		0.65		mA
					-5	5	%
			$I_{OUT} = 1\text{ A}$		0.217		mA
	-5	5		%			
$I_{OUT} = 300\text{ mA}$		0.065		mA			
		-10	10	%			
$I_{OUT} = 100\text{ mA}$		0.022		mA			
		-35	35	%			
T_J SENSE CHARACTERISTICS							
I_{SNSST}	Temperature sense current	$V_{DIA_EN} = 5\text{ V}$, $V_{SEL1} = 5\text{ V}$, $V_{SEL2} = 0\text{ V}$	$T_J = -40^\circ\text{C}$		0.12		mA
			$T_J = 25^\circ\text{C}$		0.85		mA
			$T_J = 85^\circ\text{C}$		1.52		mA
			$T_J = 150^\circ\text{C}$		2.25		mA
dI_{SNSST}/dT	Coefficient			0.0112			mA/°C
V_{BB} SENSE CHARACTERISTICS							
I_{SNSV}	Voltage sense current	$V_{DIA_EN} = 5\text{ V}$, $V_{SEL1} = 5\text{ V}$, $V_{SEL2} = 5\text{ V}$	$V_{BB} = 3\text{ V}$		0.26		mA
			$V_{BB} = 8\text{ V}$		0.69		mA
			$V_{BB} = 13.5\text{ V}$		1.17		mA
			$V_{BB} = 18\text{ V}$		1.56		mA
			$V_{BB} = 28\text{ V}$		2.43		mA
dI_{SNSV}/dV	Coefficient			0.0867			mA/V
SNS CHARACTERISTICS							
I_{SNSFH}	I_{SNS} fault high level	$V_{DIA_EN} = 5\text{ V}$, $V_{SEL1} = 0\text{ V}$, $V_{SEL2} = 0$		6	6.9	7.6	mA
$I_{SNSleak}$	I_{SNS} leakage	$V_{DIA_EN} = 0\text{ V}$		0		1	μA
$V_{SNSclamp}$	V_{SNS} clamp				5.9		V
CURRENT LIMIT CHARACTERISTICS							
I_{CL}	Current Limit	Device Version B/D	$T_J = -40^\circ\text{C}$	75.5	88.8	102.1	A
			$T_J = 25^\circ\text{C}$	68	80	92	
			$T_J = 150^\circ\text{C}$	51	60	69	
		Device Version A/C/E	$T_J = -40^\circ\text{C}$	16	22.2	27.8	A
			$T_J = 25^\circ\text{C}$	14.4	20	25	
			$T_J = 150^\circ\text{C}$	10.8	15	18.8	
ST PIN CHARACTERISTICS							
V_{OL}	Open-load detection voltage	$V_{EN} = 0\text{ V}$, $V_{DIA_EN} = 5\text{ V}$		2	2.5	4	V
t_{OL1}	OL and STB indication time - switch disabled	From falling edge of EN $V_{EN} = 5\text{ V to }0\text{ V}$, $V_{DIA_EN} = 5\text{ V}$, $V_{SELx} = 00$ $I_{OUT} = 0\text{ mA}$, $V_{OUT} = 4\text{ V}$		300	500	700	μs
t_{OL2}	OL and STB indication time - switch disabled	From rising edge of DIA_EN $V_{EN} = 0\text{ V}$, $V_{DIA_EN} = 0\text{ V to }5\text{ V}$, $V_{SELx} = 00$ $I_{OUT} = 0\text{ mA}$, $V_{OUT} = 4\text{ V}$				50	μs
t_{OL3}	OL and STB indication time - switch disabled	From rising edge of VOUT $V_{EN} = 0\text{ V}$, $V_{DIA_EN} = 5\text{ V}$, $V_{SELx} = 00$ $I_{OUT} = 0\text{ mA}$, $V_{OUT} = 0\text{ V to }4\text{ V}$				50	μs

Electrical Characteristics (continued)

 $V_{BB} = 8\text{ V to }18\text{ V}$, $T_J = -40^\circ\text{C to }150^\circ\text{C}$ (unless otherwise noted)

PARAMETER		TEST CONDITIONS	MIN	TYP	MAX	UNIT
T_{ABS}	Thermal shutdown		160	180	200	$^\circ\text{C}$
T_{HYS}	Thermal shutdown hysteresis			20		$^\circ\text{C}$
t_{RETRY}	Retry time	Minimum time from fault shutdown to switch re-enable (for thermal shutdown, current limit, and energy limit)	1	2	3	ms
t_{WD}	Watchdog timer	Device version E	350	400	450	ms
EN PIN CHARACTERISTICS⁽¹⁾						
$V_{IL, EN}$	Input voltage low level				1.5	V
$V_{IH, EN}$	Input voltage high level	No GND network Diode	2			V
$V_{IHYS, EN}$	Input voltage hysteresis	No GND network Diode		250		mV
$I_{IL, EN}$	Input current low level	$V_{EN} = 0.8\text{ V}$		0.8		μA
$I_{IH, EN}$	Input current high level	$V_{EN} = 2.0\text{ V}$		2		μA
R_{EN}	Internal pulldown resistor			1		$\text{M}\Omega$
DIA_EN PIN CHARACTERISTICS⁽¹⁾						
V_{IL, DIA_EN}	Input voltage low level	No GND network Diode			1.5	V
V_{IH, DIA_EN}	Input voltage high level	No GND network Diode	2			V
V_{IHYS, DIA_EN}	Input voltage hysteresis			250		mV
I_{IL, DIA_EN}	Input current low level	$V_{DIA_EN} = 0.8\text{ V}$		0.8		μA
I_{IH, DIA_EN}	Input current high level	$V_{DIA_EN} = 2.0\text{ V}$		2		μA
R_{DIA_EN}	Internal pulldown resistor			1		$\text{M}\Omega$
SEL1 AND SEL2 PIN CHARACTERISTICS⁽¹⁾						
$V_{IL, SELx}$	Input voltage low level	No GND network Diode			1.5	V
$V_{IH, SELx}$	Input voltage high level		2			V
$V_{IHYS, SELx}$	Input voltage hysteresis			250		mV
$I_{IL, SELx}$	Input current low level	$V_{SELx} = 0.8\text{ V}$		0.8		μA
$I_{IH, SELx}$	Input current high level	$V_{SELx} = 2.0\text{ V}$		2		μA
R_{SELx}	Internal pulldown resistor			1		$\text{M}\Omega$
LATCH PIN CHARACTERISTICS⁽¹⁾						
$V_{IL, LATCH}$	Input voltage low level	No GND network Diode			1.5	V
$V_{IH, LATCH}$	Input voltage high level	No GND network Diode	2			V
$V_{IHYS, LATCH}$	Input voltage hysteresis			250		mV
$I_{IL, LATCH}$	Input current low level	$V_{LATCH} = 0.8\text{ V}$		0.8		μA
$I_{IH, LATCH}$	Input current high level	$V_{LATCH} = 2.0\text{ V}$		2		μA
R_{LATCH}	Internal pulldown resistor			1		$\text{M}\Omega$
ST PIN CHARACTERISTICS⁽¹⁾						
$V_{OL, ST}$	Output voltage low level	$I_{ST} = 1\text{ mA}$			0.4	V
I_{STleak}	Leakage current	$V_{ST} = 5\text{ V}$			2	μA

(1) $V_{BB} = 3\text{ to }28\text{ V}$

7.6 Switching Characteristics

 $V_{BB} = 13.5\text{ V}$, $T_J = -40^\circ\text{C to }150^\circ\text{C}$ (unless otherwise noted)

PARAMETER		TEST CONDITIONS	MIN	TYP	MAX	UNIT
t_{DR}	Turn-on delay time	$V_{BB} = 13.5\text{ V}$, $R_L = 2.6\ \Omega$	20	70	100	μs
t_{DF}	Turn-off delay time	$V_{BB} = 13.5\text{ V}$, $R_L = 2.6\ \Omega$	20	50	100	μs
SR_R	VO _{UT} rising slew rate	$V_{BB} = 13.5\text{ V}$, 20% to 80% of V_{OUT} , $R_L = 2.6\ \Omega$	0.1	0.35	0.7	V/ μs

Switching Characteristics (continued)

 $V_{BB} = 13.5\text{ V}$, $T_J = -40^\circ\text{C}$ to 150°C (unless otherwise noted)

PARAMETER		TEST CONDITIONS	MIN	TYP	MAX	UNIT
SR_F	VOUT falling slew rate	$V_{BB} = 13.5\text{ V}$, 80% to 20% of V_{OUT} , $R_L = 2.6\ \Omega$	0.1	0.5	0.7	V/ μs
t_{ON}	Turn-on time	$V_{BB} = 13.5\text{ V}$, $R_L = 2.6\ \Omega$	39	80	145	μs
t_{OFF}	Turn-off time	$V_{BB} = 13.5\text{ V}$, $R_L = 2.6\ \Omega$	39	75	145	μs
$t_{ON} - t_{OFF}$	Turn-on and off matching	200- μs enable pulse	-50	0	50	μs
E_{ON}	Switching energy losses during turn-on	$V_{BB} = 13.5\text{ V}$, $R_L = 2.6\ \Omega$		0.4		mJ
E_{OFF}	Switching energy losses during turn-off	$V_{BB} = 13.5\text{ V}$, $R_L = 2.6\ \Omega$		0.4		mJ

7.7 SNS Timing Characteristics

 $V_{BB} = 8$ to 18 V , $T_J = -40^\circ\text{C}$ to 150°C (unless otherwise noted)

PARAMETER		TEST CONDITIONS	MIN	TYP	MAX	UNIT
SNS TIMING - CURRENT SENSE						
$t_{SNSION1}$	Settling time from rising edge of DIA_EN	$V_{EN} = 5\text{ V}$, $V_{DIA_EN} = 0\text{ V}$ to 5 V $R_{SNS} = 1\text{ k}\Omega$, $R_L = 2.6\ \Omega$			40	μs
$t_{SNSION2}$	Settling time from rising edge of EN	$V_{EN} = V_{DIA_EN} = 0\text{ V}$ to 5 V $R_{SNS} = 1\text{ k}\Omega$, $R_L = 2.6\ \Omega$			180	μs
$t_{SNSION3}$	Settling time from rising edge of EN	$V_{EN} = 0\text{ V}$ to 5 V , $V_{DIA_EN} = 5\text{ V}$ $R_{SNS} = 1\text{ k}\Omega$, $R_L = 2.6\ \Omega$			180	μs
$t_{SNSIOFF1}$	Settling time from falling edge of DIA_EN	$V_{EN} = 5\text{ V}$, $V_{DIA_EN} = 5\text{ V}$ to 0 V $R_{SNS} = 1\text{ k}\Omega$, $R_L = 2.6\ \Omega$			20	μs
$t_{SETTLEH}$	Settling time from rising edge of load step	$V_{EN} = 5\text{ V}$, $V_{DIA_EN} = 5\text{ V}$ $R_{SNS} = 1\text{ k}\Omega$, $I_{OUT} = 1\text{ A}$ to 5 A			20	μs
$t_{SETTLEL}$	Settling time from falling edge of load step	$V_{EN} = 5\text{ V}$, $V_{DIA_EN} = 5\text{ V}$ $R_{SNS} = 1\text{ k}\Omega$, $I_{OUT} = 5\text{ A}$ to 1 A			20	μs
SNS TIMING - TEMPERATURE SENSE						
$t_{SNSSTON1}$	Settling time from rising edge of DIA_EN	$V_{EN} = 5\text{ V}$, $V_{DIA_EN} = 0\text{ V}$ to 5 V $R_{SNS} = 1\text{ k}\Omega$			40	μs
$t_{SNSSTON2}$	Settling time from rising edge of DIA_EN	$V_{EN} = 0\text{ V}$, $V_{DIA_EN} = 0\text{ V}$ to 5 V $R_{SNS} = 1\text{ k}\Omega$			70	μs
$t_{SNSSTOFF}$	Settling time from falling edge of DIA_EN	$V_{EN} = X$, $V_{DIA_EN} = 5\text{ V}$ to 0 V $R_{SNS} = 1\text{ k}\Omega$			20	μs
SNS TIMING - VOLTAGE SENSE						
$t_{SNSVON1}$	Settling time from rising edge of DIA_EN	$V_{EN} = 5\text{ V}$, $V_{DIA_EN} = 0\text{ V}$ to 5 V $R_{SNS} = 1\text{ k}\Omega$			40	μs
$t_{SNSVON2}$	Settling time from rising edge of DIA_EN	$V_{EN} = 0\text{ V}$, $V_{DIA_EN} = 0\text{ V}$ to 5 V $R_{SNS} = 1\text{ k}\Omega$			70	μs
$t_{SNSVOFF}$	Settling time from falling edge of DIA_EN	$V_{EN} = X$, $V_{DIA_EN} = 5\text{ V}$ to 0 V $R_{SNS} = 1\text{ k}\Omega$			20	μs
SNS TIMING - MULTIPLEXER						

SNS Timing Characteristics (continued)
 $V_{BB} = 8 \text{ to } 18 \text{ V}$, $T_J = -40^\circ\text{C to } 150^\circ\text{C}$ (unless otherwise noted)

PARAMETER		TEST CONDITIONS	MIN	TYP	MAX	UNIT
t_{MUX}	Settling time from temperature sense to current sense	$V_{EN} = X$, $V_{DIA_EN} = 5 \text{ V}$ $V_{SEL1} = 5 \text{ V to } 0 \text{ V}$, $V_{SEL2} = 0 \text{ V}$ $R_{SNS} = 1 \text{ k}\Omega$, $R_L = 2.6 \Omega$			60	μs
	Settling time from temperature sense to voltage sense	$V_{EN} = X$, $V_{DIA_EN} = 5 \text{ V}$ $V_{SEL1} = 5 \text{ V}$, $V_{SEL2} = 0 \text{ V to } 5 \text{ V}$ $R_{SNS} = 1 \text{ k}\Omega$			60	μs
	Settling time from voltage sense to temperature sense	$V_{EN} = X$, $V_{DIA_EN} = 5 \text{ V}$ $V_{SEL1} = 5 \text{ V}$, $V_{SEL2} = 5 \text{ V to } 0 \text{ V}$ $R_{SNS} = 1 \text{ k}\Omega$			60	μs
	Settling time from voltage sense to current sense	$V_{EN} = X$, $V_{DIA_EN} = 5 \text{ V}$ $V_{SEL1} = V_{SEL2} = 5 \text{ V to } 0 \text{ V}$, $R_{SNS} = 1 \text{ k}\Omega$, $R_L = 2.6 \Omega$			60	μs
	Settling time from current sense to temperature sense	$V_{EN} = X$, $V_{DIA_EN} = 5 \text{ V}$ $V_{SEL1} = 0 \text{ V to } 5 \text{ V}$, $V_{SEL2} = 0 \text{ V}$ $R_{SNS} = 1 \text{ k}\Omega$, $R_L = 2.6 \Omega$			60	μs
	Settling time from current sense to voltage sense	$V_{EN} = X$, $V_{DIA_EN} = 5 \text{ V}$ $V_{SEL1} = V_{SEL2} = 0 \text{ V to } 5 \text{ V}$ $R_{SNS} = 1 \text{ k}\Omega$, $R_L = 2.6 \Omega$			60	μs

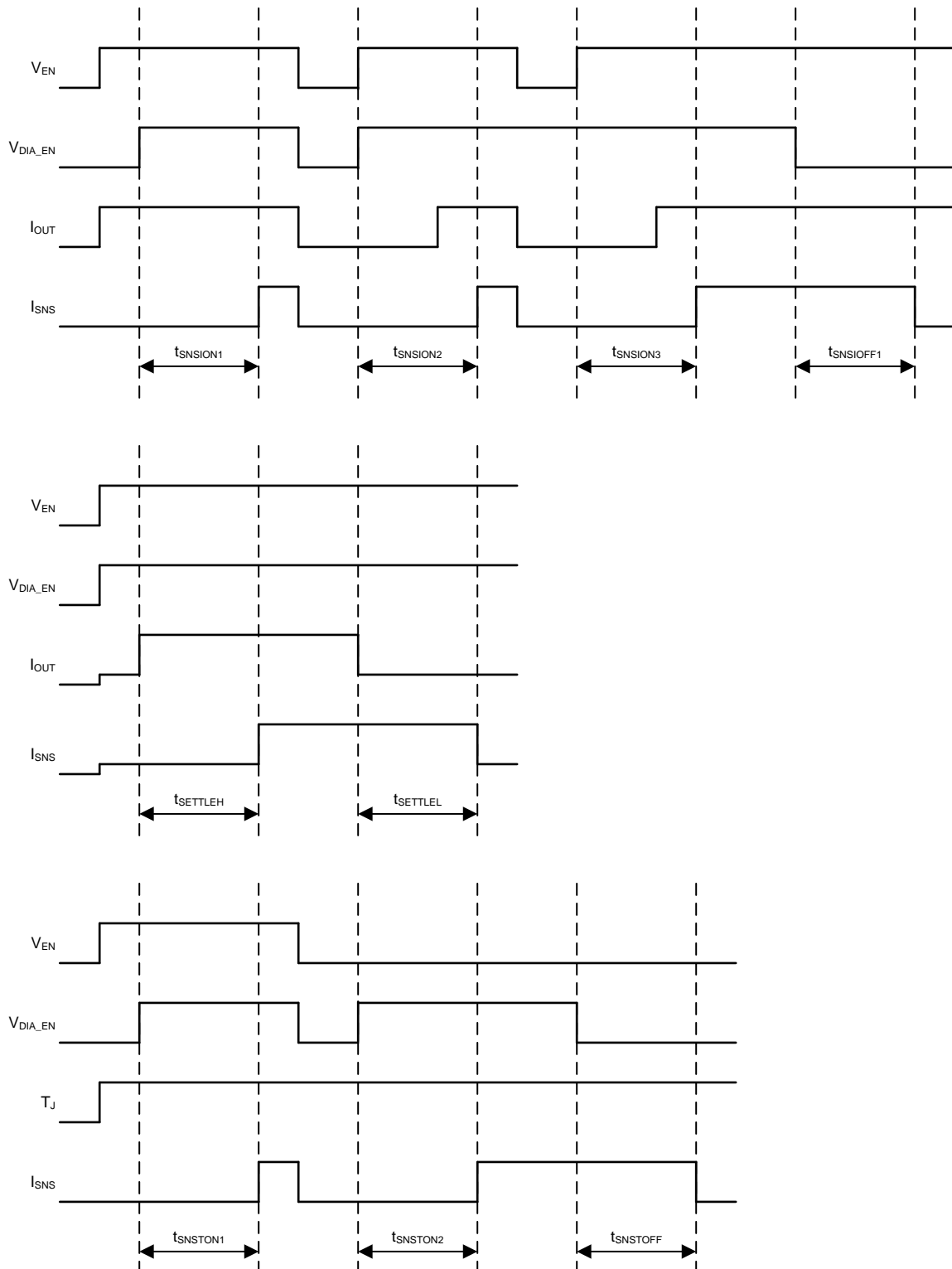

NOTES: Rise and fall times of control signals are 100 ns. Control signals include: EN, DIA_EN, SEL1, SEL2.

SEL1 and SEL2 must be set to the appropriate values.

The temperature sense timing diagram can also be used to depict the voltage sense timings.

Figure 1. SNS Timing Characteristics Definitions

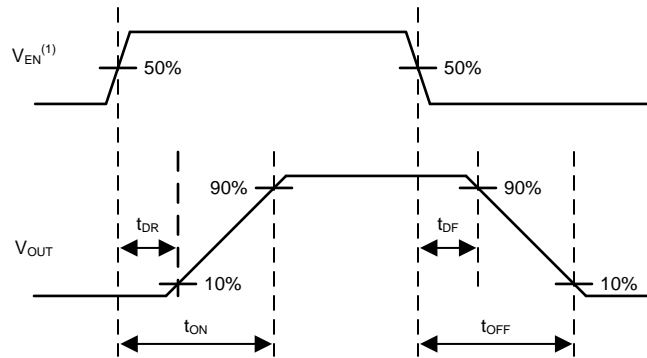

Rise and fall time of V_{EN} is 100 ns.

Figure 2. Switching Characteristics Definitions

7.8 Typical Characteristics

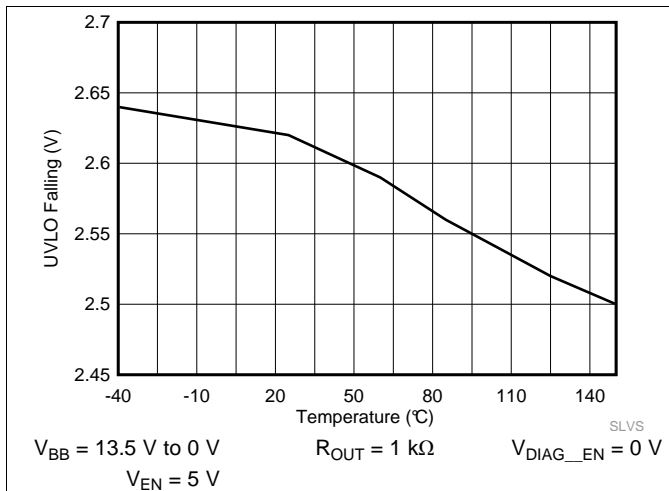

Figure 3. Falling Undervoltage Lockout (V_{UVLOF}) vs Temperature

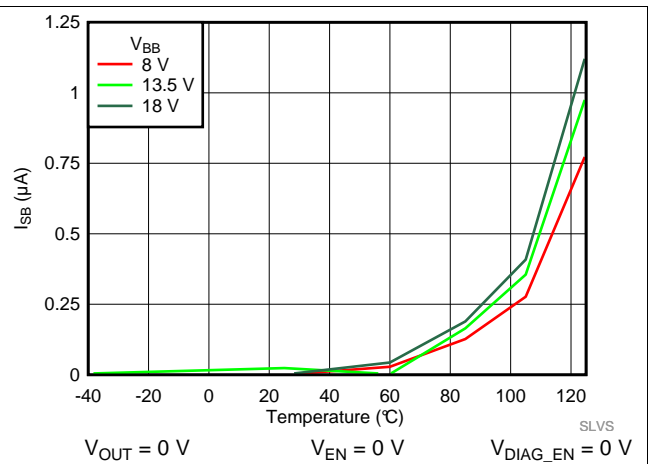

Figure 4. Standby Current (I_{SB}) vs Temperature

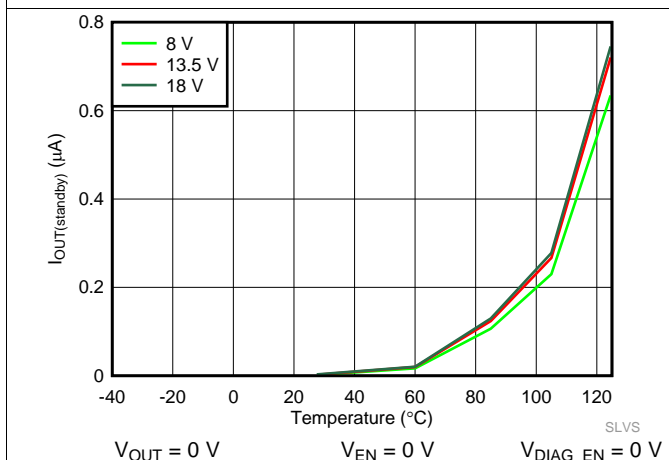

Figure 5. Output Leakage Current ($I_{OUT(\text{standby})}$) vs Temperature

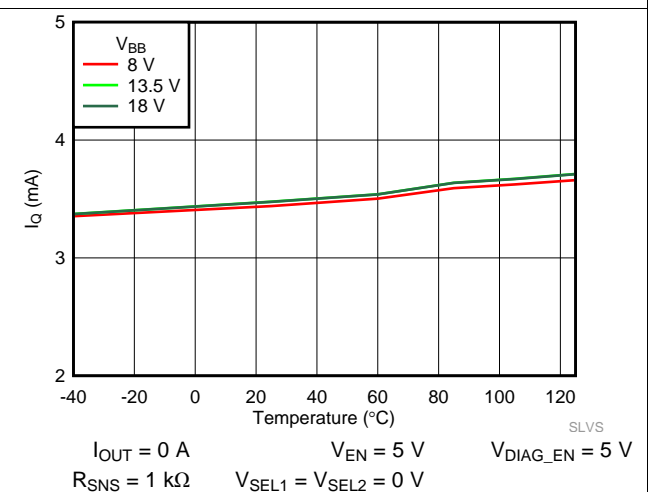
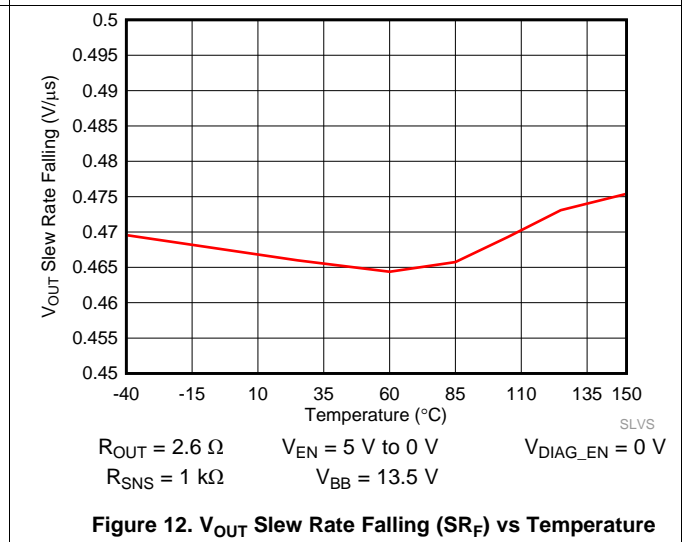
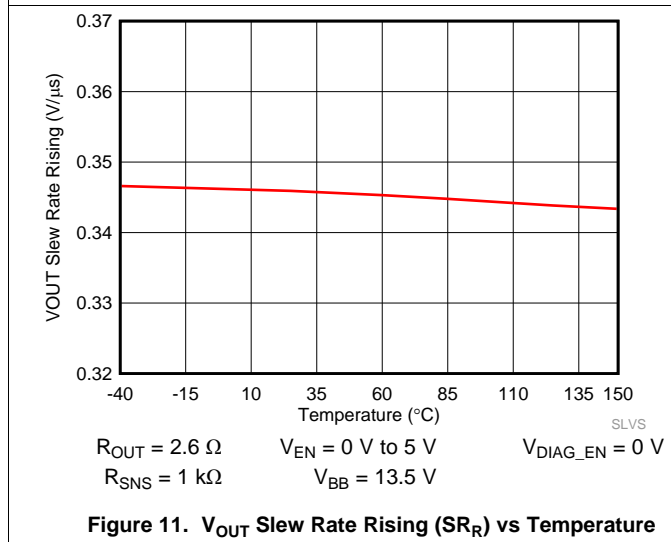
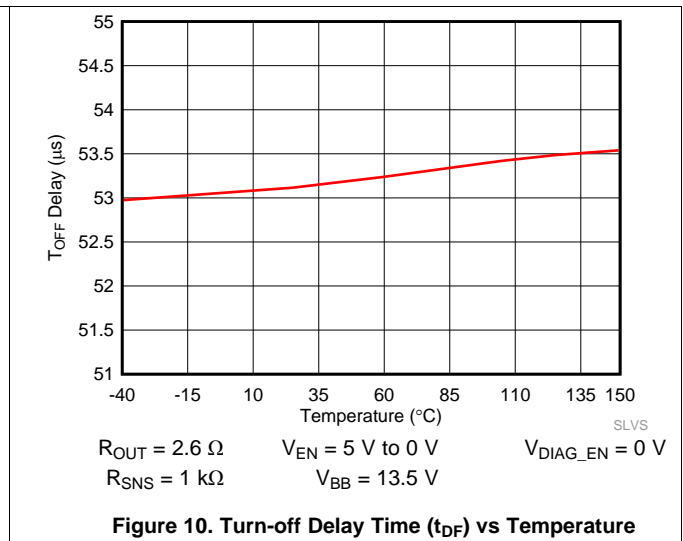
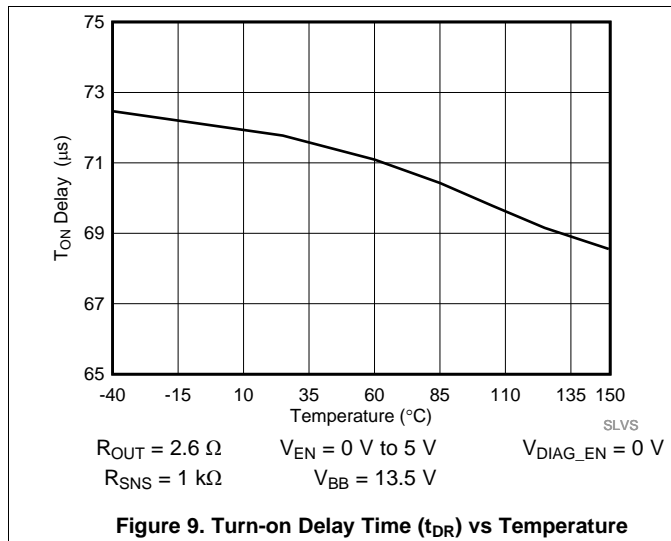
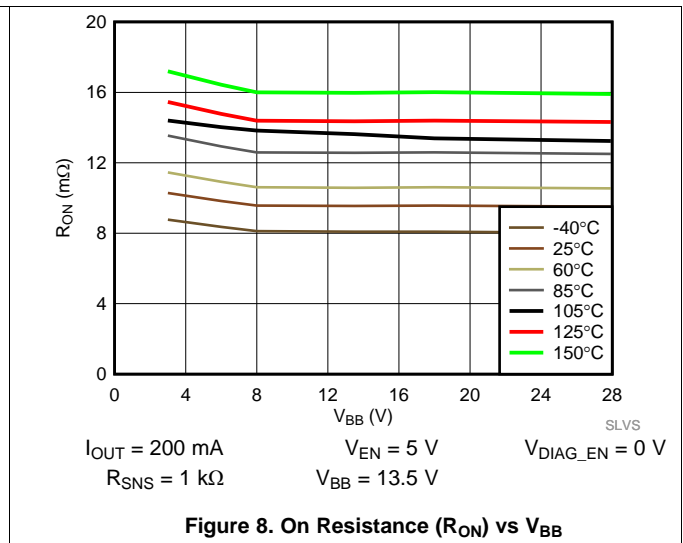
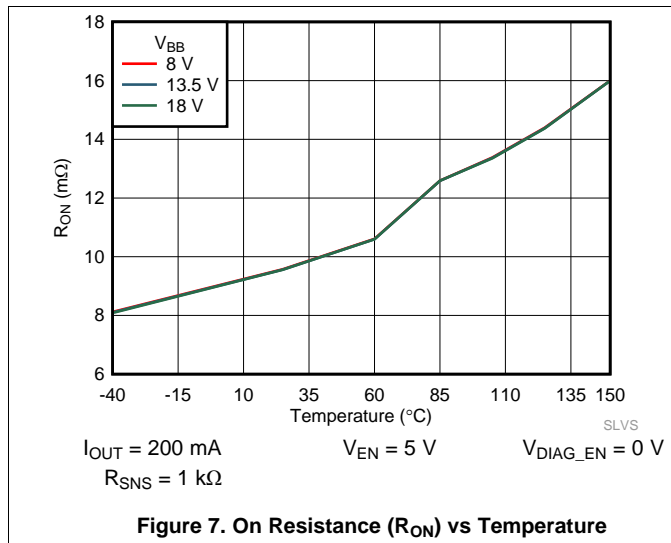
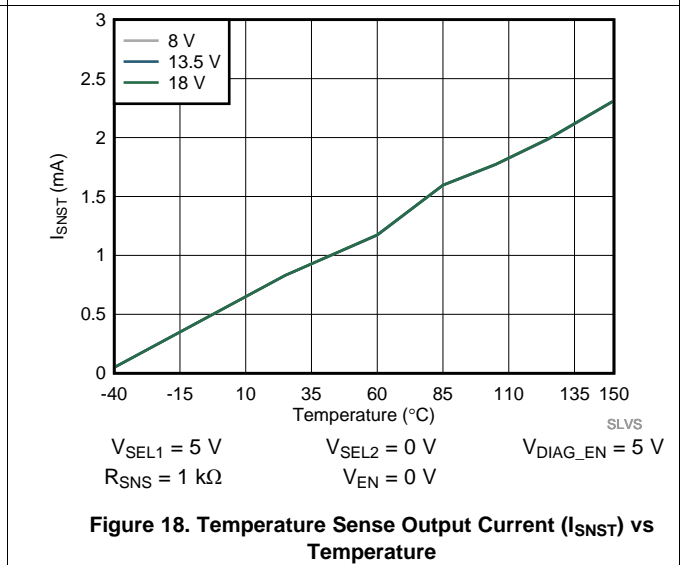
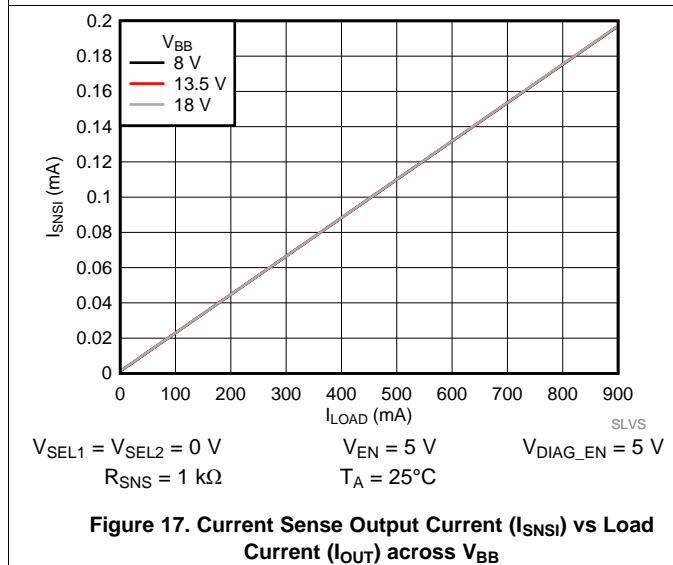
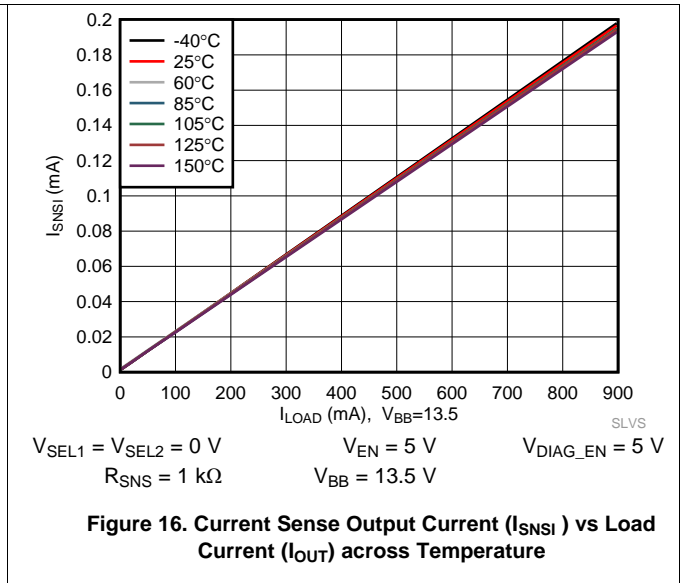
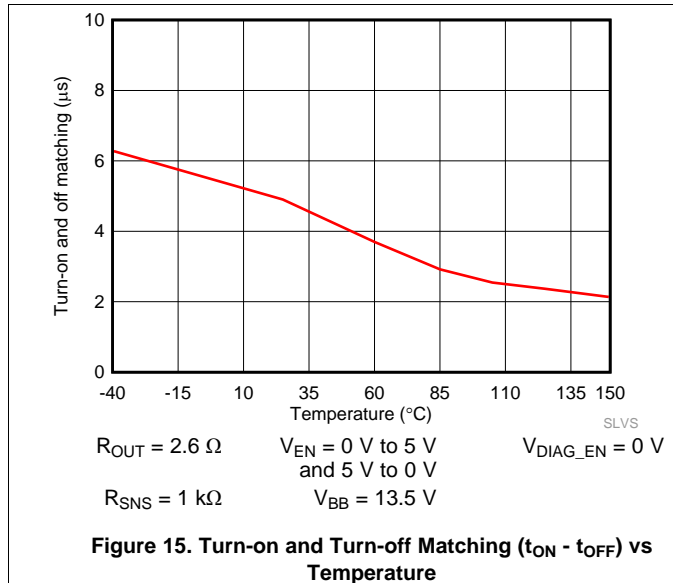
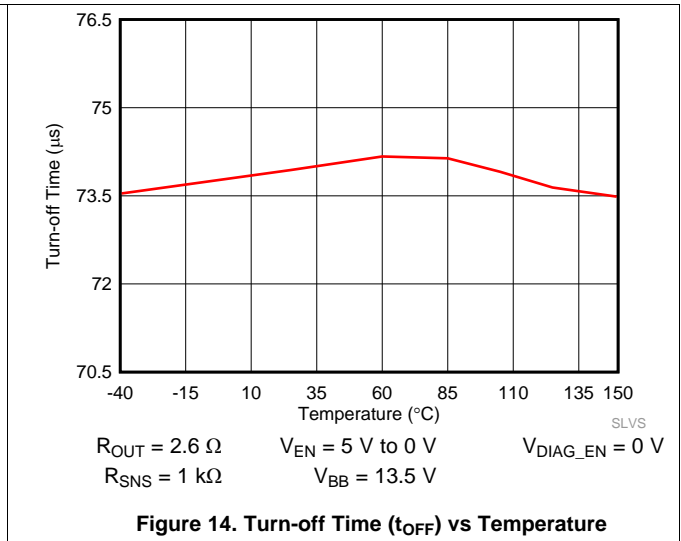
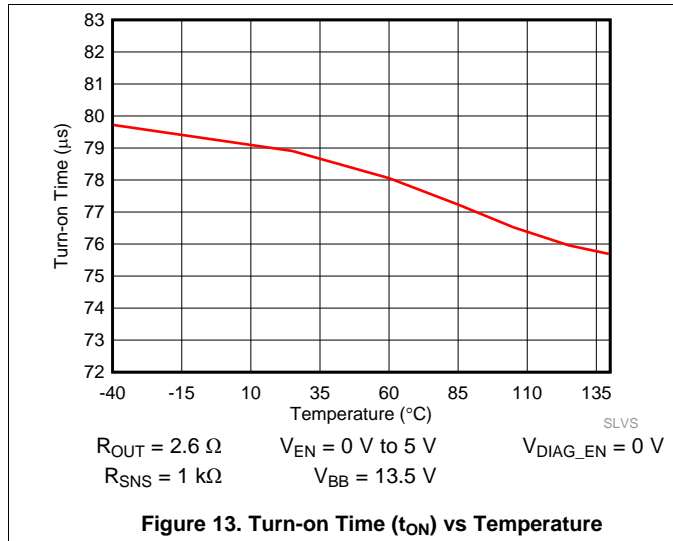

Figure 6. Quiescent Current (I_Q) vs Temperature

Typical Characteristics (continued)



Typical Characteristics (continued)



Typical Characteristics (continued)

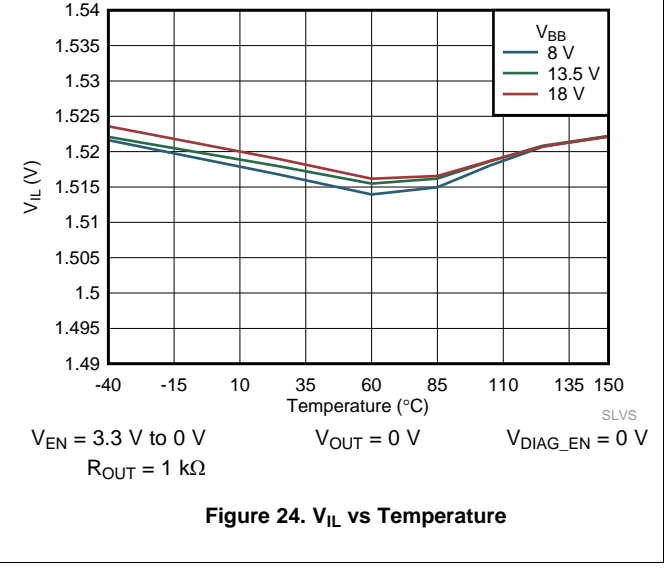
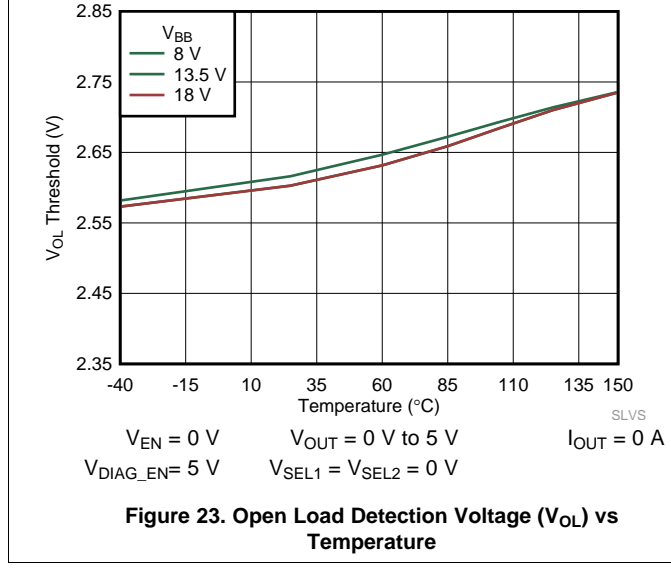
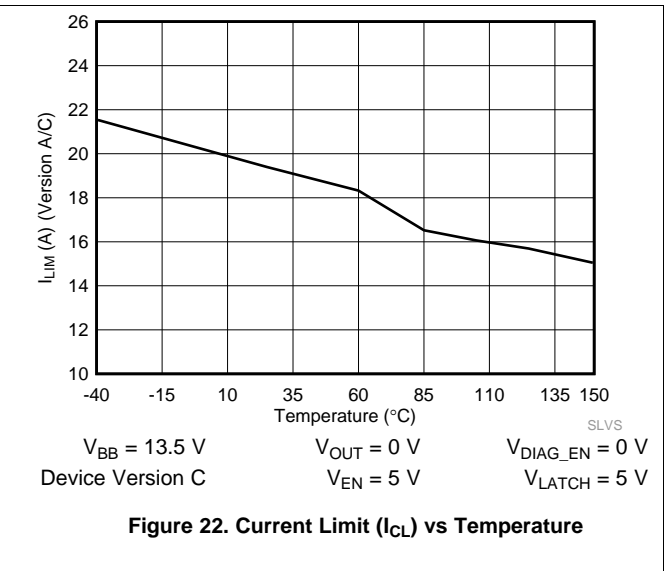
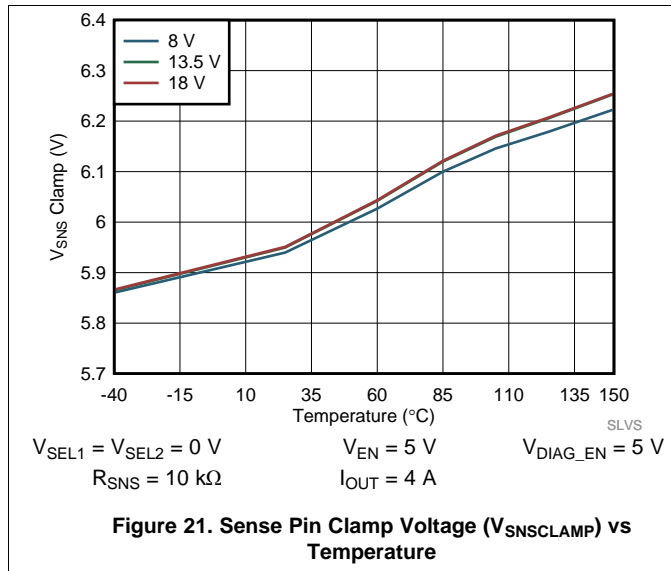
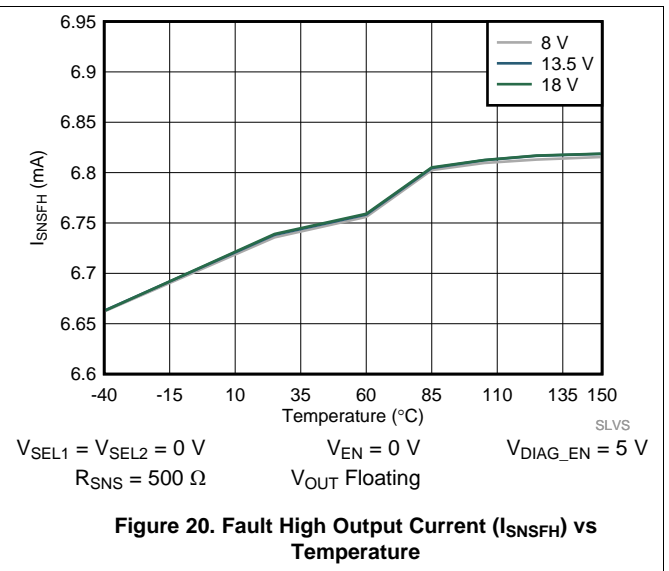
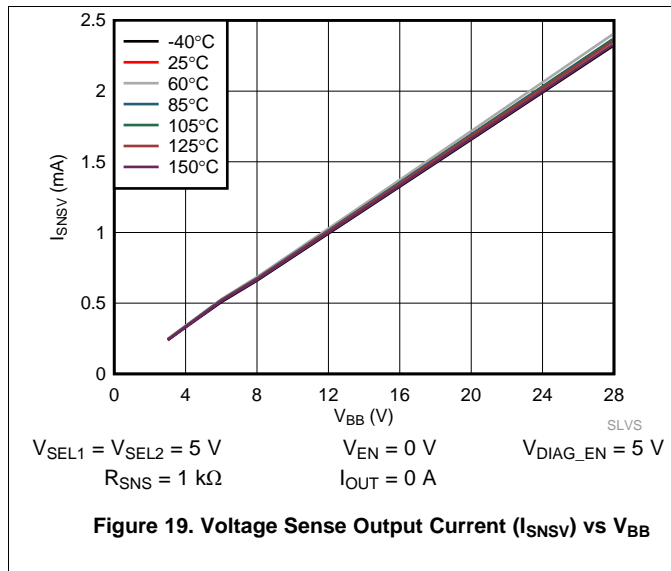

Typical Characteristics (continued)

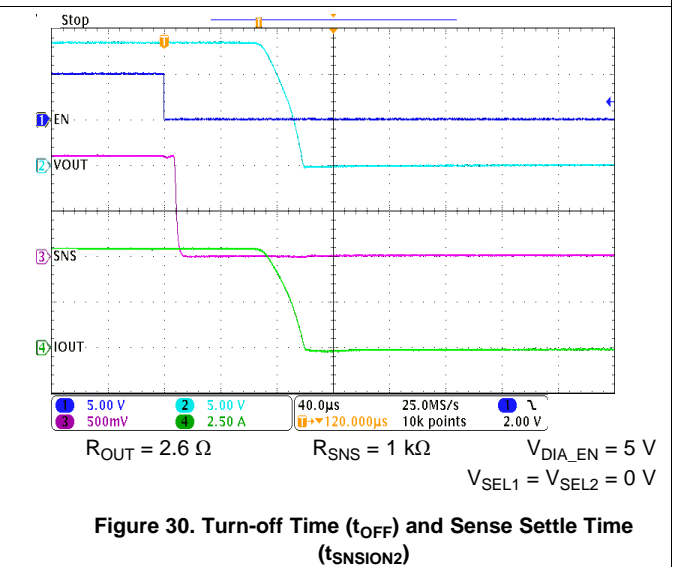
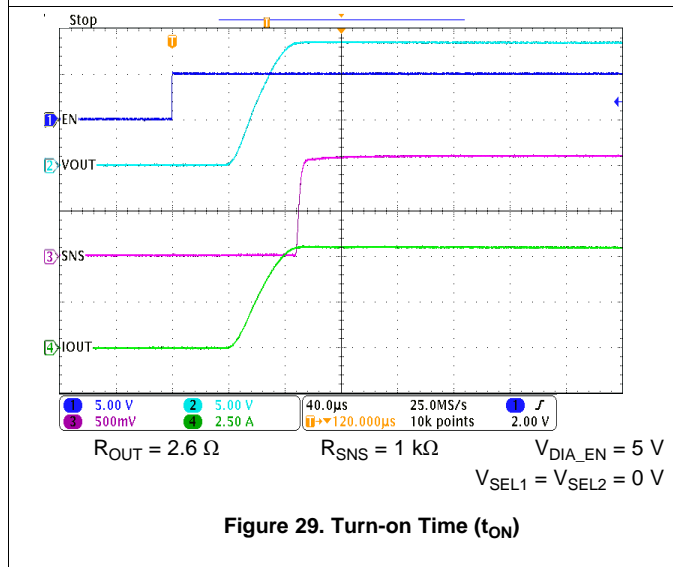
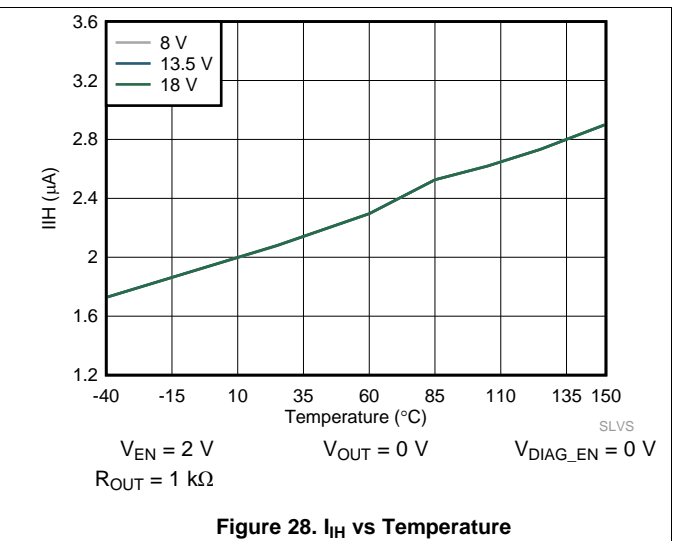
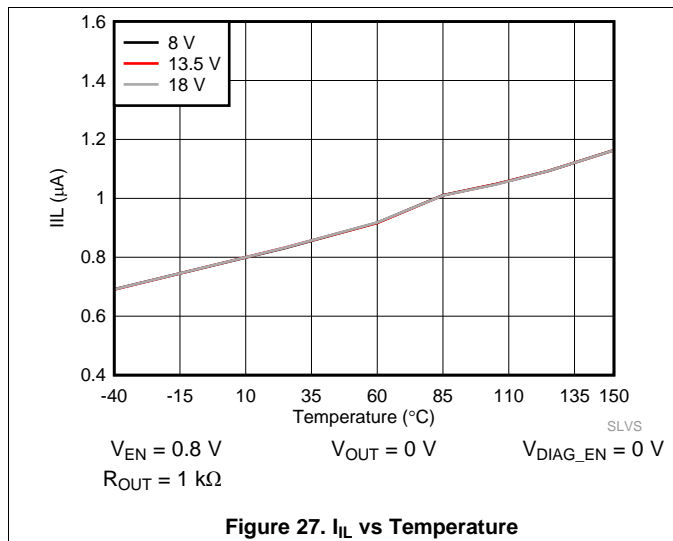
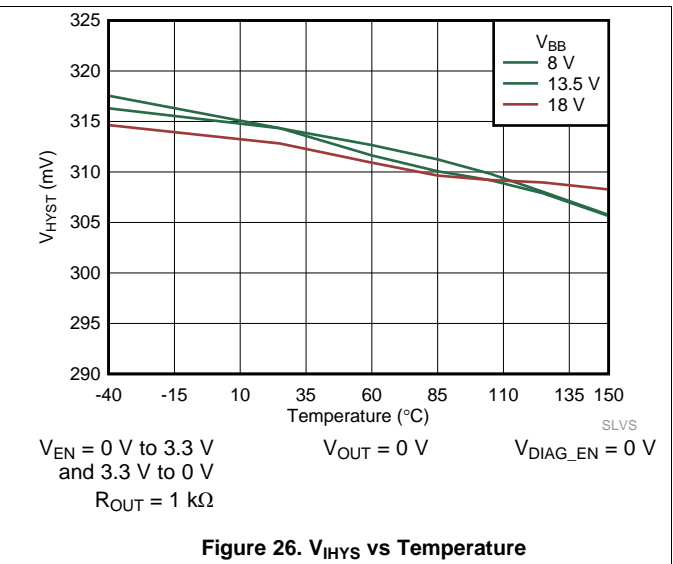
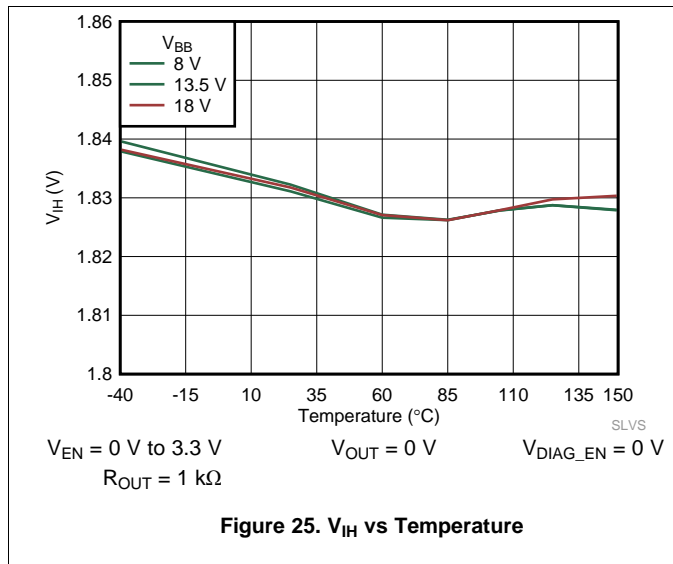

Typical Characteristics (continued)

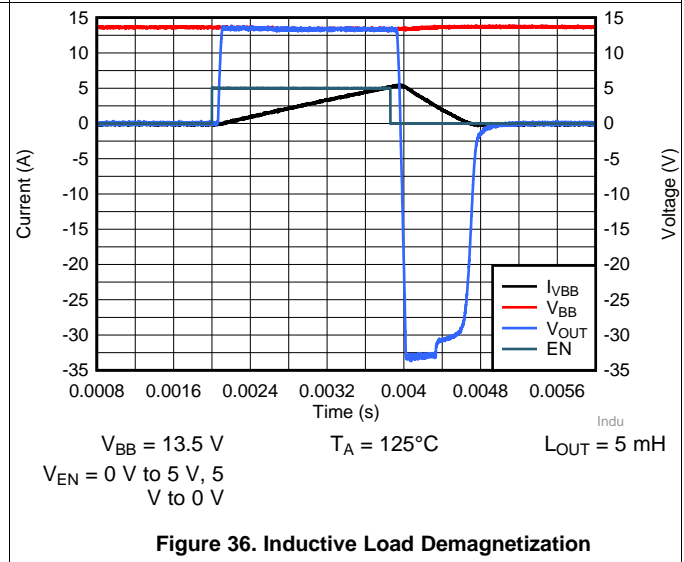
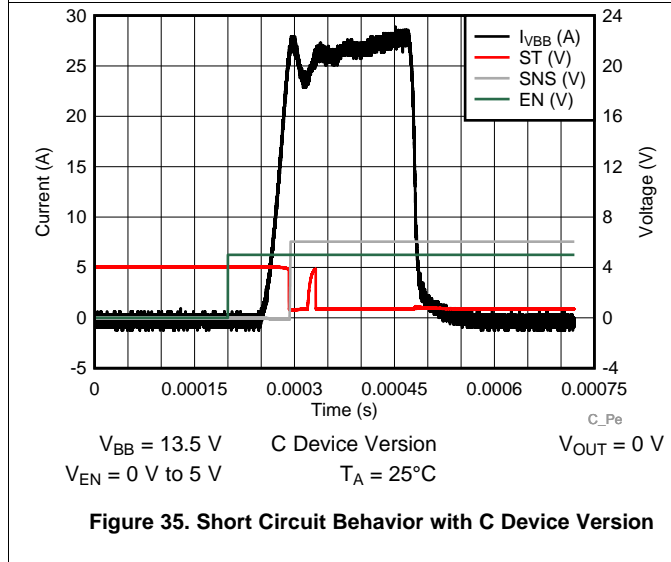
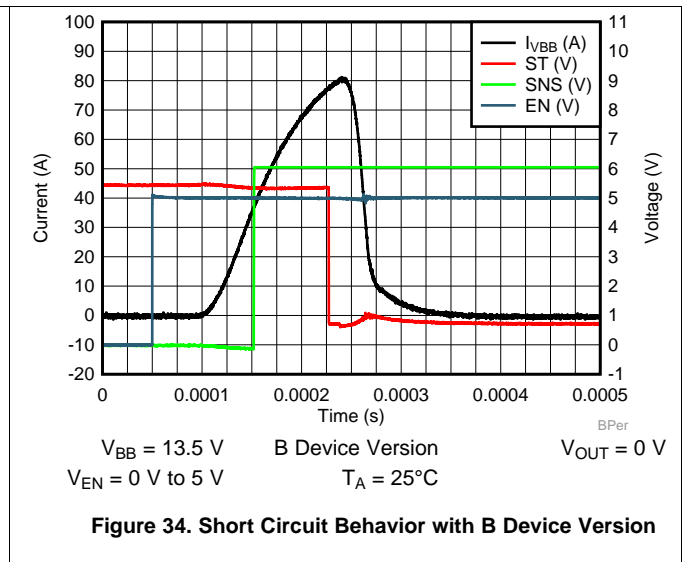
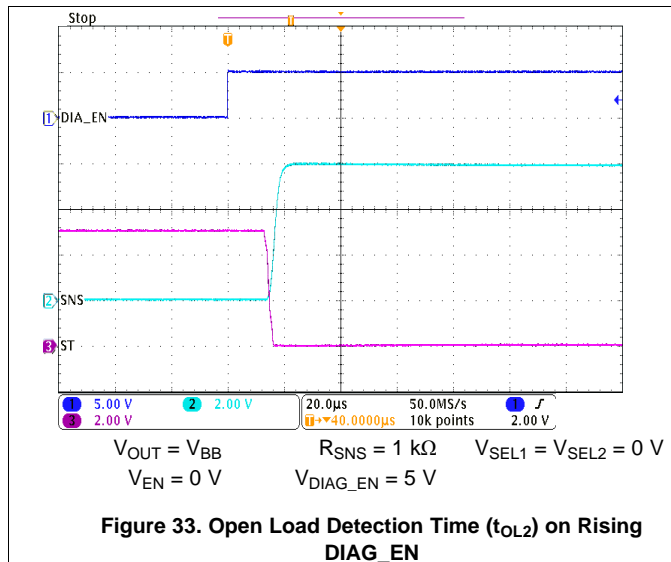
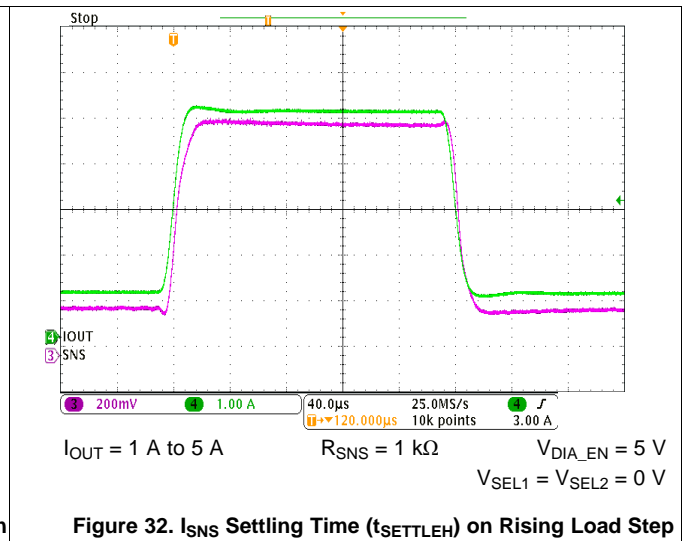
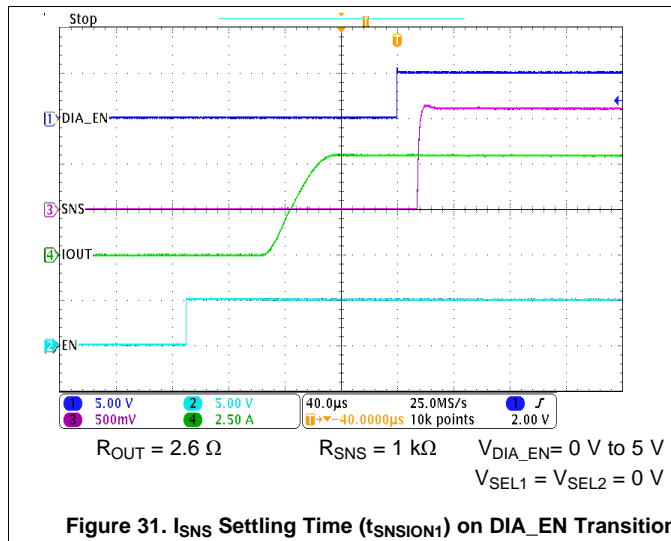

8 Parameter Measurement Information

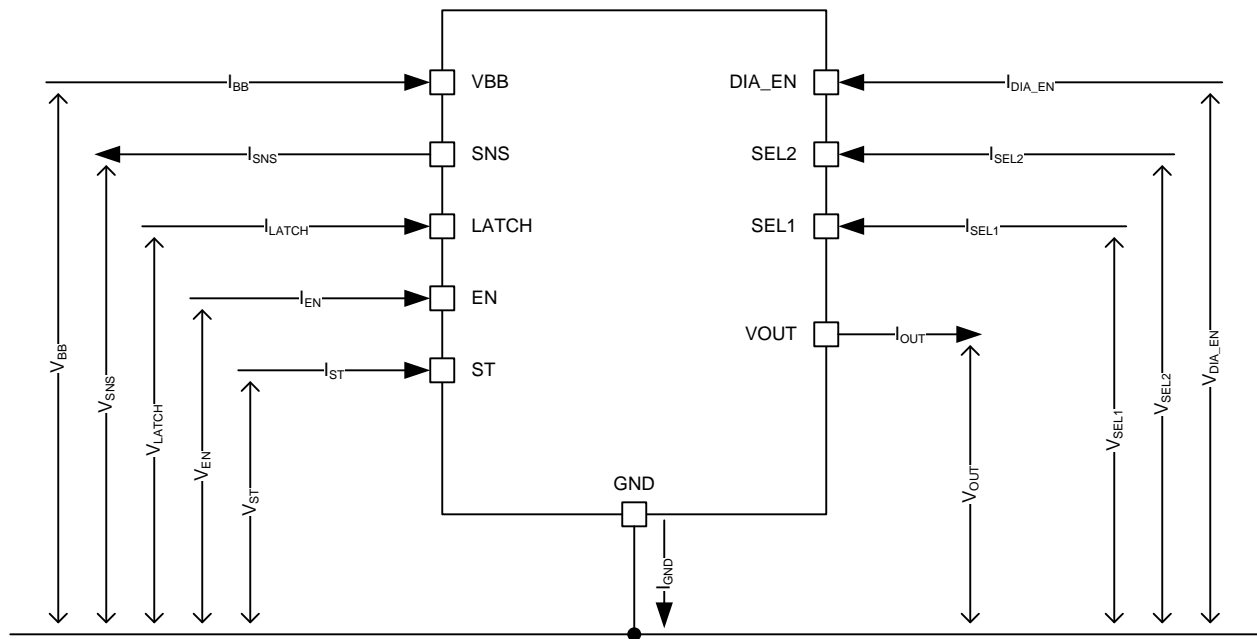

Figure 37. Parameter Definitions

9 Detailed Description

9.1 Overview

The TPS1HA08-Q1 device is a single-channel smart high-side power switch intended for use with 12 V automotive batteries. Many protection and diagnostic features are integrated in the device.

Diagnostics features include the analog SNS output and the open-drain fault indication (\overline{ST}). The analog SNS output is capable of providing a signal that is proportional to device temperature, supply voltage, or load current. The high-accuracy load current sense allows for diagnostics of complex loads.

This device includes protection through thermal shutdown, current limit, transient withstand, and reverse battery operation. For more details on the protection features, refer to the [Feature Description](#) and [Application Information](#) sections of the document.

9.1.1 Device Nomenclature

The TPS1HA08-Q1 is one device in the TI family of Smart High Side Switches. [Figure 38](#) shows the family part number nomenclature and explains how to determine device characteristics from the part number for TI Smart High Side Switches.

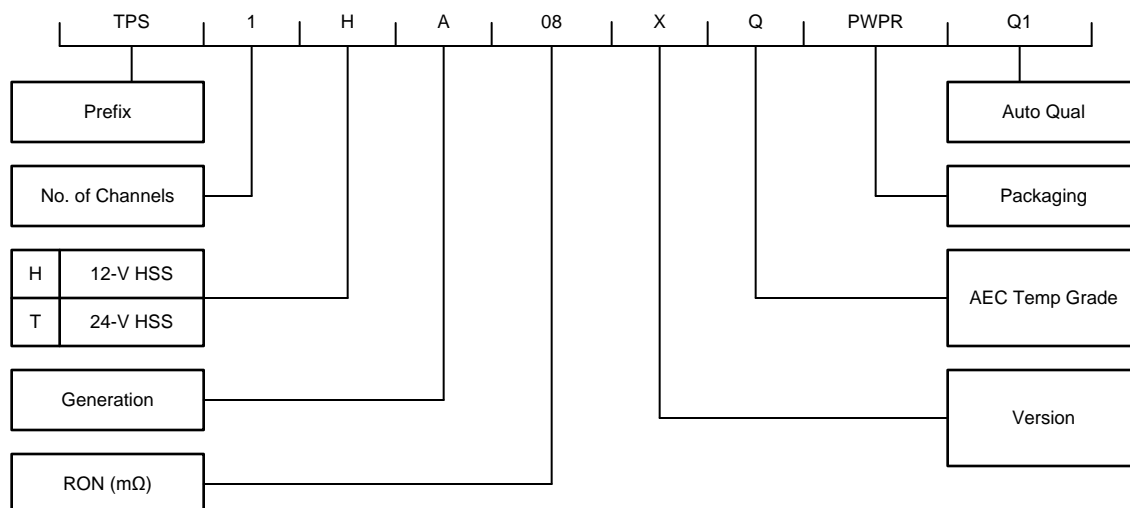
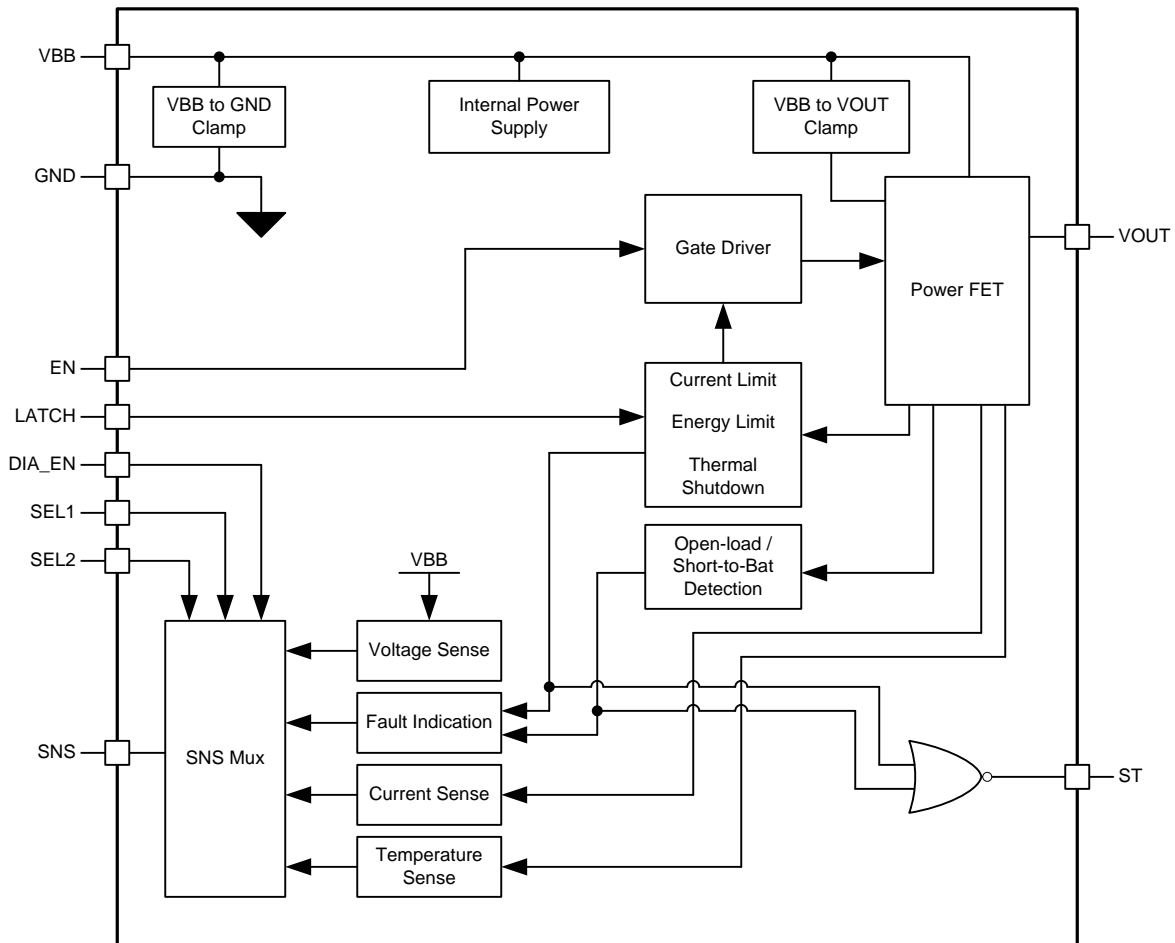

Figure 38. Naming Convention

9.2 Functional Block Diagram



9.3 Feature Description

9.3.1 Protection Mechanisms

The TPS1HA08-Q1 is designed to operate in the automotive environment. The protection mechanisms allow the device to be robust against many system-level events such as load dump, reverse battery, short-to-ground and more.

There are three protection features which, if triggered, will cause the switch to automatically disable:

- Thermal Shutdown
- Current Limit (Versions A,B,E)
- Energy Limit

When any of these protections are triggered, the device will enter the FAULT state. In the FAULT state, the fault indication will be available on both the SNS pin and the \overline{ST} pin (see the diagnostic section of the data sheet for more details).

The switch is no longer held off and the fault indication is reset when all of the below conditions are met:

- LATCH pin is low
- t_{RETRY} has expired
- All faults are cleared (thermal shutdown, current limit, energy limit)

9.3.1.1 Thermal Shutdown

The TPS1HA08-Q1 includes temperature sensors on the FET and inside of the device controller. When $T_{J,FET} > T_{ABS}$, the device will see a thermal shutdown fault. After the fault is detected, the switch will turn off. The fault is cleared when the switch temperature decreases by the hysteresis value, T_{HYS} .

9.3.1.2 Current Limit

When I_{OUT} reaches the current limit threshold, I_{CL} , the device can switch off immediately (Versions A,B,E), or the device can remain enabled and limit I_{OUT} (Versions C/D) to I_{CL} (see [Device Comparison Table](#) section for more details). In the case that the device remains enabled and limits I_{OUT} , the thermal shutdown and/or energy limit protection feature may be triggered due to the high amount of power dissipation in the device.

During a short circuit event, the device will hit the I_{CL} threshold that is listed in the [Specifications](#) (for the given device version) and then turn the output off or regulate the output current to protect the device. The device will register a short circuit event when the output current exceeds I_{CL} , however the measured maximum current may exceed the I_{CL} threshold due to the TPS1HA08-Q1 deglitch filter and turn-off time. The device is guaranteed to protect itself during a short circuit event over the nominal supply voltage range (as defined in the [Specifications](#) section) at 125°C.

9.3.1.2.1 Current Limit Foldback

The TPS1HA08-Q1 implements a current limit foldback feature that is designed to protect the device in the case of a long-term fault condition. If the device undergoes three consecutive fault shutdown events (any of thermal shutdown, current limit, or energy limit), the current limit will be reduced to half of the original value. The device will revert back to the original current limit threshold if either of the following occurs:

- The device goes to [Standby Delay](#).
- The switch turns-on and turns-off without any fault occurring.

9.3.1.2.2 Selectable Current Limit Threshold

The TPS1HA08-Q1 offers two current limit thresholds. The high threshold is designed to allow for a large transient load current (for example, inrush current of a 65-W bulb). The low threshold is designed to provide improved system-level protection for loads that do not have large transient currents (for example, heating element). The lower threshold can allow for reduced size/cost in the current carrying components such as PCB traces and module connectors. Version A (20 A current limit) is ideal for charging capacitors, as it will enable the device to prevent inrush current and clamp the overcurrent to linearly charge the capacitor.

Feature Description (continued)

9.3.1.2.3 Undervoltage Lockout (UVLO)

The device monitors the supply voltage V_{BB} to prevent unpredicted behaviors in the event that the supply voltage is too low. When the supply voltage falls down to V_{UVLOF} , the output stage is shut down automatically. When the supply rises up to V_{UVLOR} , the device turns back on.

9.3.1.2.4 V_{BB} during Short-to-Ground

When V_{OUT} is shorted to ground, the module power supply (V_{BB}) can have a transient decrease. This is caused by the sudden increase in current flowing through the wiring harness cables. To achieve ideal system behavior, it is recommended that the module maintain $V_{BB} > 3\text{ V}$ during V_{OUT} short-to-ground. This is typically accomplished by placing bulk capacitance on the power supply node.

9.3.1.3 Energy Limit

The energy limiting feature is implemented to protect the switch from excessive stress. The device will continuously monitor the amount of energy dissipated in the FET. If the energy limit threshold is reached, the switch will automatically disable. In practice, the energy limit will only be reached during a fault event such as short-to-ground.

Energy limit events have the same system-level behavior as thermal shutdown events.

9.3.1.4 Voltage Transients

The TPS1HA08-Q1 contains two voltage clamps which protect the device against system-level voltage transients.

The clamp from V_{BB} to GND is primarily used to protect the controller from positive transients on the supply line (for example, ISO7637-2). The clamp from V_{BB} to V_{OUT} is primarily used to limit the voltage across the FET when switching off an inductive load. Both clamp levels are set to protect the device during these fault conditions. If the voltage potential from V_{BB} to GND exceeds the V_{BB} clamp level, the clamp will allow current to flow through the device from V_{BB} to GND (Path 2). If the voltage potential from V_{BB} to V_{OUT} exceeds V_{CLAMP} , the power FET will allow current to flow from V_{BB} to V_{OUT} (Path 3).

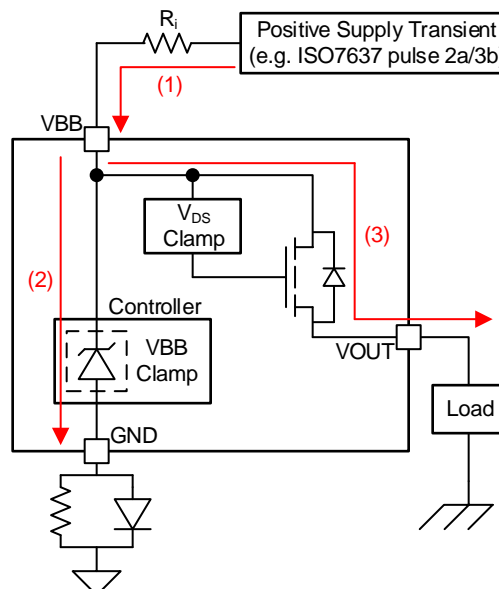

Figure 39. Current Path During Supply Voltage Transient

9.3.1.4.1 Load Dump

The TPS1HA08-Q1 is tested according to ISO 16750-2:2010(E) suppressed load dump pulse. The device supports up to 40 V load dump transient. The switch will maintain normal operation during the load dump pulse. If the switch is enabled, it will stay enabled. If the switch is disabled, it will stay disabled.

Feature Description (continued)

9.3.1.4.2 Driving Inductive and Capacitive Loads

When switching off an inductive load, the inductor may impose a negative voltage on the output of the switch. The TPS1HA08-Q1 includes a voltage clamp to limit voltage across the FET. The maximum acceptable load inductance is a function of the device robustness. With a 5 mH load, the TPS1HA08-Q1 can withstand a single pulse of 95 mJ inductive dissipation at 125°C and can withstand 56 mJ of inductive dissipation with a 10 Hz repetitive pulse. If the application parameters exceed this device limit, it is necessary to use a protection device like a freewheeling diode to dissipate the energy stored in the inductor. Figure 40 shows the TPS1HA08-Q1 discharging a 5 mH load that is driven at 5 A.

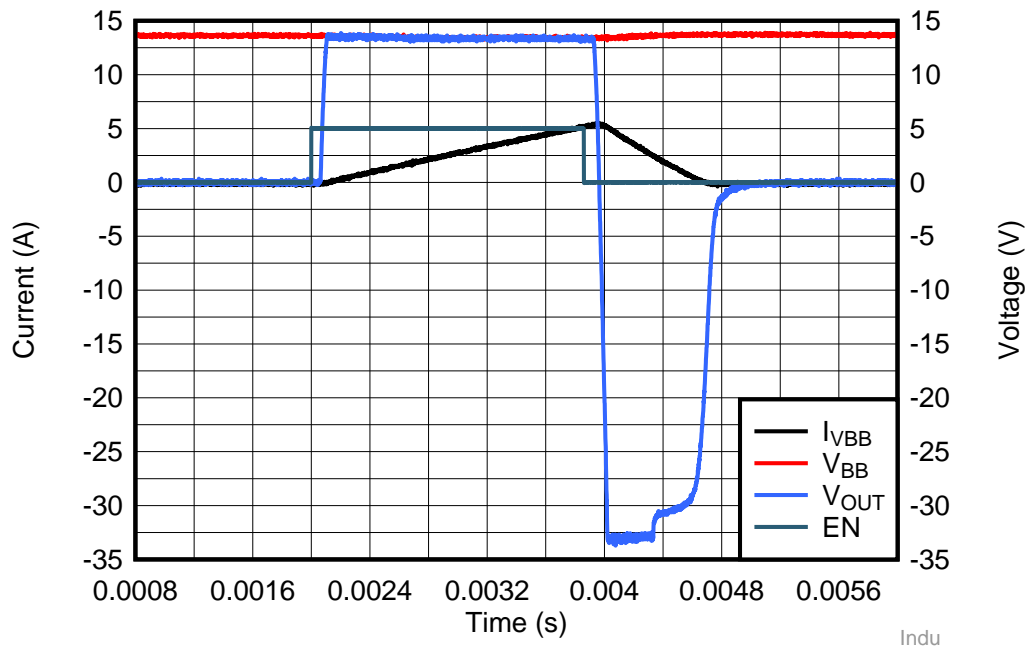

Figure 40. Inductive Discharge (5 mH, 5 A)

In addition, the TPS1HA08-Q1 current limit provides an ideal way to charge a capacitive load safely with limited inrush current. With no protection, charging a large capacitive load can lead to high inrush currents that pull a supply down, however by using the low current limit device options the capacitive load can be safely charged.

For more information on driving inductive or capacitive loads, reference TI's ["How To Drive Inductive, Capacitive, and Lighting Loads with Smart High Side Switch"](#) application report.

9.3.1.5 Reverse Battery

In the reverse battery condition, the switch will automatically be enabled (regardless of EN status) to prevent power dissipation inside the MOSFET body diode. In many applications (for example, resistive load), the full load current may be present during reverse battery. In order to activate the automatic switch on feature, the SEL2 pin must have a path to module ground. This may be path 1 as shown below, or, if the SEL2 pin is unused, the path may be through R_{PROT} to module ground.

Protection features (for example, thermal shutdown) are not available during reverse battery. Care must be taken to ensure that excessive power is not dissipated in the switch during the reverse battery condition.

There are two options for blocking reverse current in the system. Option 1 is to place a blocking device (FET or diode) in series with the battery supply. This will block all current paths. Option 2 is to place a blocking diode in series with the GND node of the high-side switch. This method will protect the controller portion of the switch (path 2), but it will not prevent current from flowing through the load (path 3). The diode used for Option 2 may be shared amongst multiple high-side switches.

Path 1 shown in Figure 41 is blocked inside of the device.

Feature Description (continued)

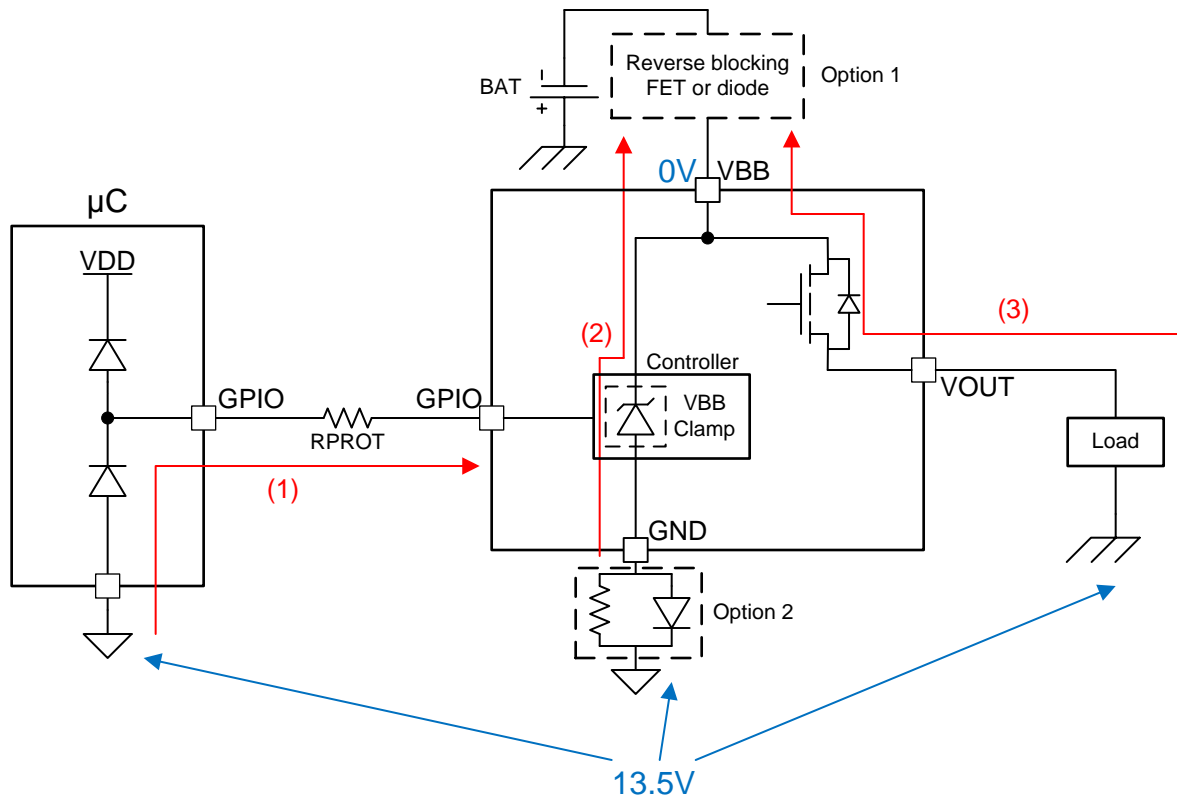

Figure 41. Current Path During Reverse Battery

9.3.1.6 Fault Event – Timing Diagrams

NOTE

All timing diagrams assume that the SELx pins are set to 00.

The LATCH, DIA_EN, and EN pins are controlled by the user. The timing diagrams represent a possible use-case.

Figure 42 shows the immediate current limit switch off behavior of Versions A,B,E. The diagram also illustrates the retry behavior. As shown, the switch will remain latched off until the LATCH pin is low.

Feature Description (continued)

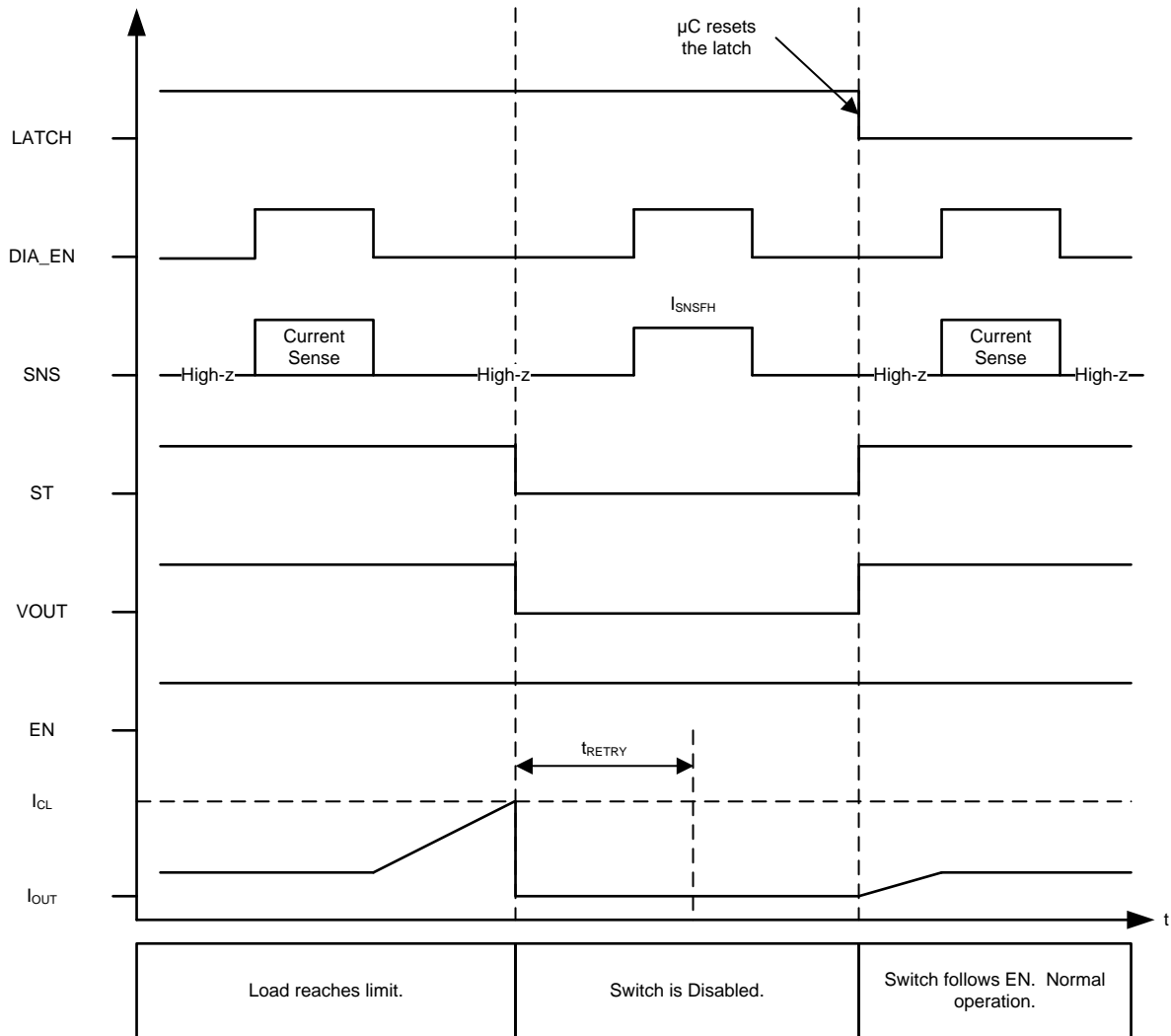

Figure 42. Current Limit – Version A,B,E - Latched Behavior

Figure 43 shows the immediate current limit switch off behavior of versions A,B,E. In this example, LATCH is tied to GND; hence, the switch will retry after the fault is cleared and t_{RETRY} has expired.

Feature Description (continued)

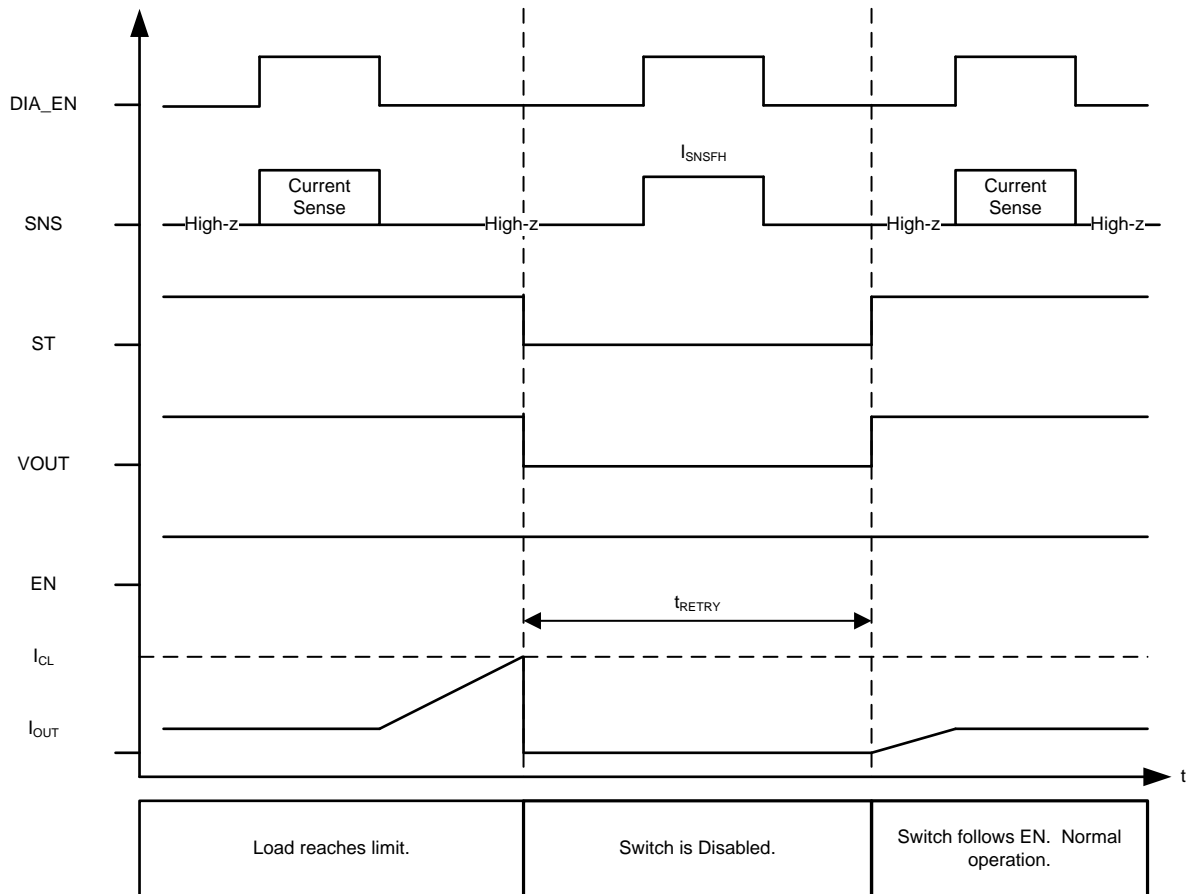

Figure 43. Current Limit – Version A,B,E - LATCH = 0

Figure 44 shows the active current limiting behavior of versions C,D. In versions C,D, the switch will not shutdown until either the energy limit or the thermal shutdown is reached.

Feature Description (continued)

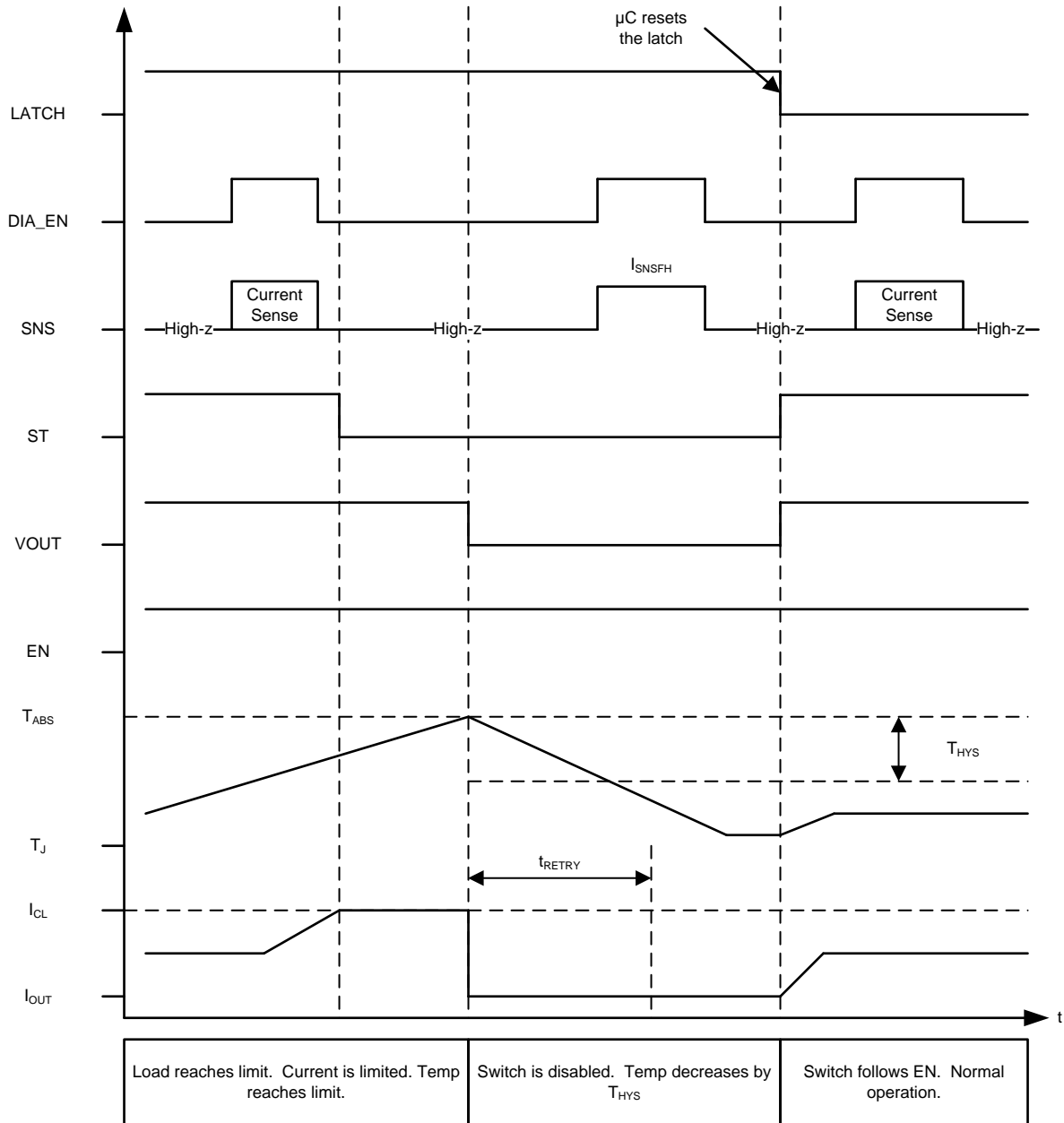

Figure 44. Current Limit – Version C,D - Latched Behavior

Figure 45 shows the active current limiting behavior of versions C,D. The switch will not shutdown until either thermal shutdown or energy limit is tripped. In this example, LATCH is tied to GND.

Feature Description (continued)

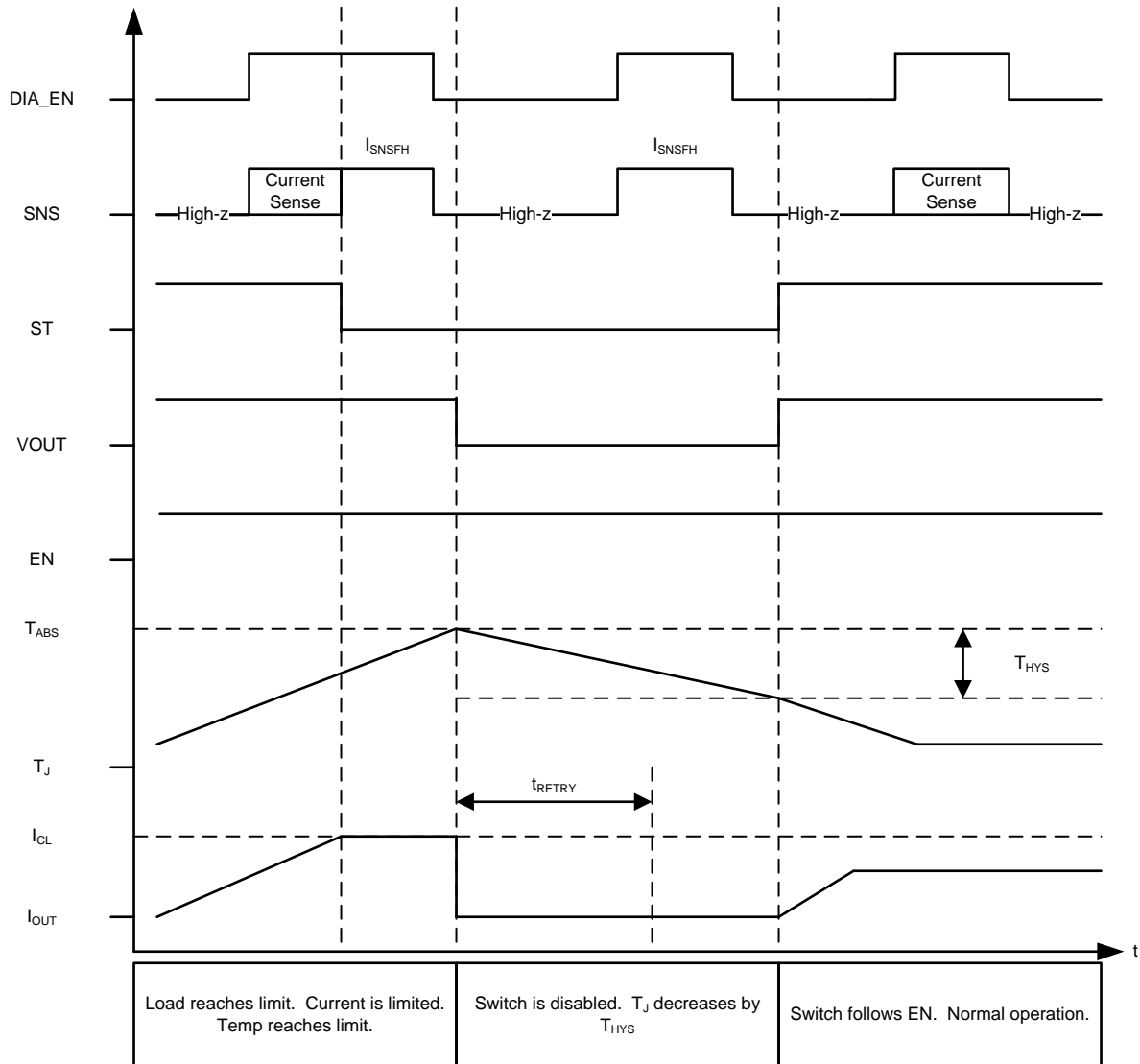

Figure 45. Current Limit – Version C,D - LATCH = 0

When the switch retries after a shutdown event, the SNS fault indication will remain until V_{OUT} has risen to V_{BB} – 1.8 V. Once V_{OUT} has risen, the SNS fault indication is reset and current sensing is available. ST fault indication is reset as soon as the switch is re-enabled (does not wait for V_{OUT} to rise). If there is a short-to-ground and V_{OUT} is not able to rise, the SNS fault indication will remain indefinitely. The following diagram illustrates auto-retry behavior and provides a zoomed-in view of the fault indication during retry.

NOTE

Figure 46 assumes that t_{RETRY} has expired by the time that T_J reaches the hysteresis threshold.

LATCH = 0 V and DIA_EN = 5 V

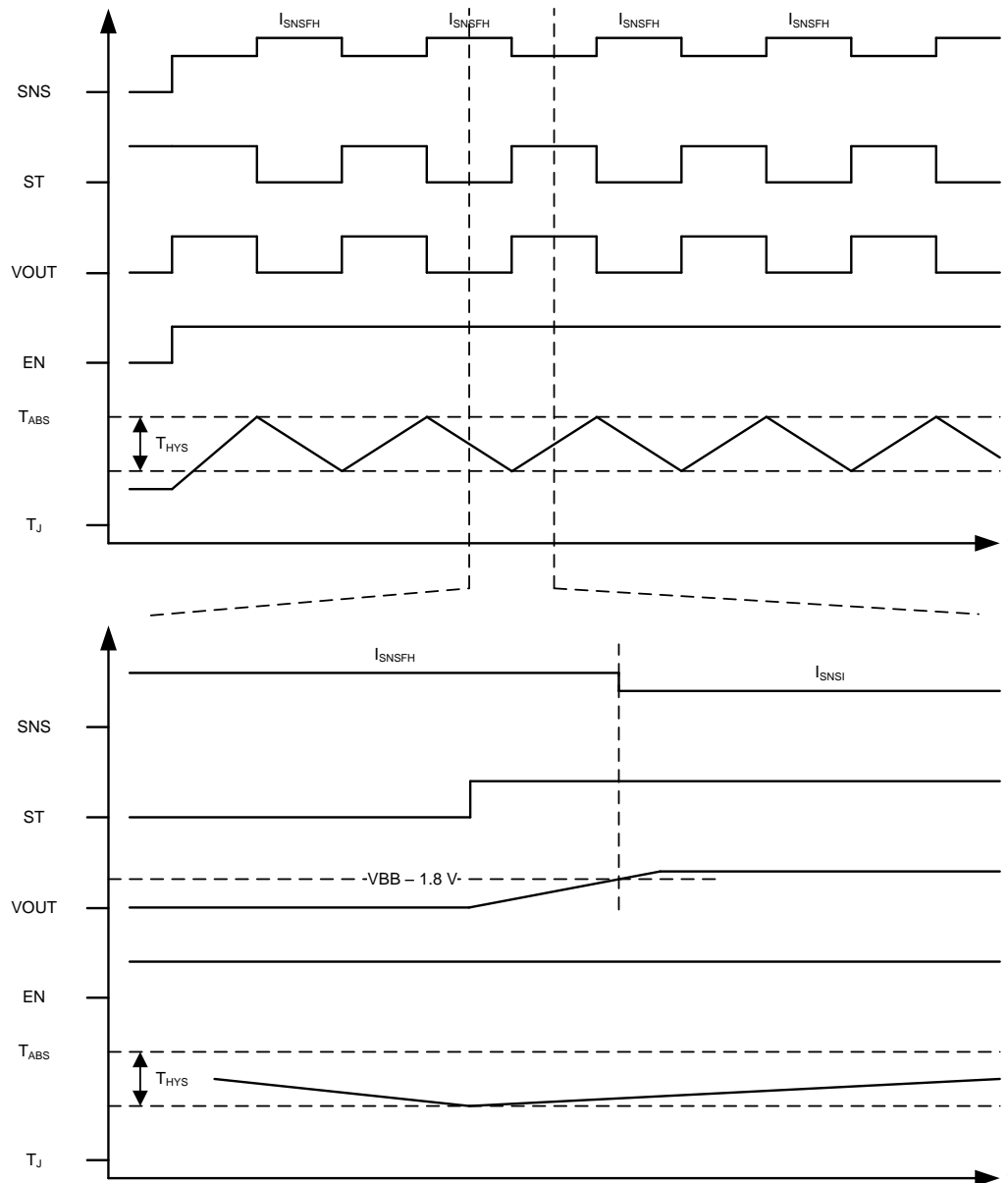
Feature Description (continued)

Figure 46. Fault Indication During Retry
9.3.2 Diagnostic Mechanisms
9.3.2.1 V_{OUT} Short-to-Battery and Open-Load
9.3.2.1.1 Detection With Switch Enabled

When the switch is enabled, the V_{OUT} short-to-battery and open-load conditions can be detected with the current sense feature. In both cases, the load current will be measured through the SNS pin and will be below the expected value.

Feature Description (continued)

9.3.2.1.2 Detection With Switch Disabled

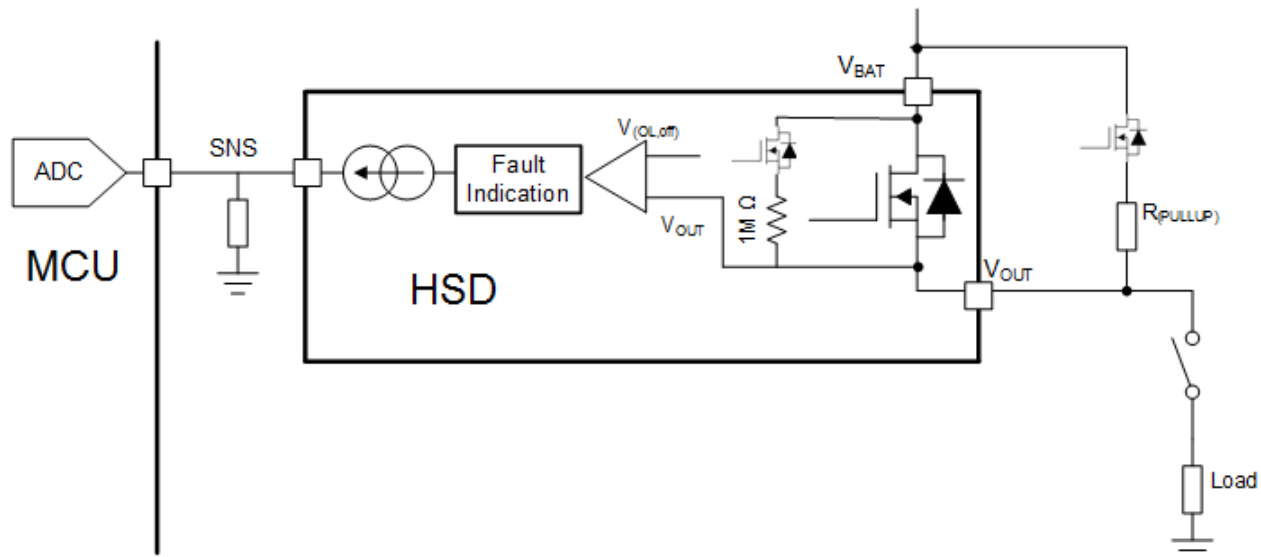
While the switch is disabled, if DIA_EN is high, an internal comparator will detect the condition of V_{OUT} . If the load is disconnected (open load condition) or there is a short to battery the V_{OUT} voltage will be higher than the open load threshold ($V_{OL,off}$) and a fault is indicated on the SNS pin. An internal pull-up of $1\text{ M}\Omega$ is in series with an internal MOSFET switch, so no external component is required if only a completely open load needs to be detected. However, if there is significant leakage or other current draw even when the load is disconnected, a lower value pull-up resistor and switch can be added externally to set the V_{OUT} voltage above the $V_{OL,off}$ during open load conditions.



- (1) This figure assumes that the device ground and the load ground are at the same potential. In application, there may be a ground shift voltage of 1 V to 2 V.

Figure 47. Short to Battery and Open Load Detection

The detection circuitry is only enabled when DIA_EN = HIGH and EN = LOW.

If $V_{OUT} > V_{OL}$, the SNS pin will go to the fault level.

If $V_{OUT} < V_{OL}$, then there is no fault indication.

The fault indication will only occur if the SEL1 pin is set to diagnose the channel.

While the switch is disabled and DIA_EN is high, the fault indication mechanisms will continuously represent the present status. For example, if V_{OUT} decreases from $>V_{OL}$ to $<V_{OL}$, the fault indication is reset. Additionally, the fault indication is reset upon the falling edge of DIA_EN or the rising edge of EN.

Feature Description (continued)

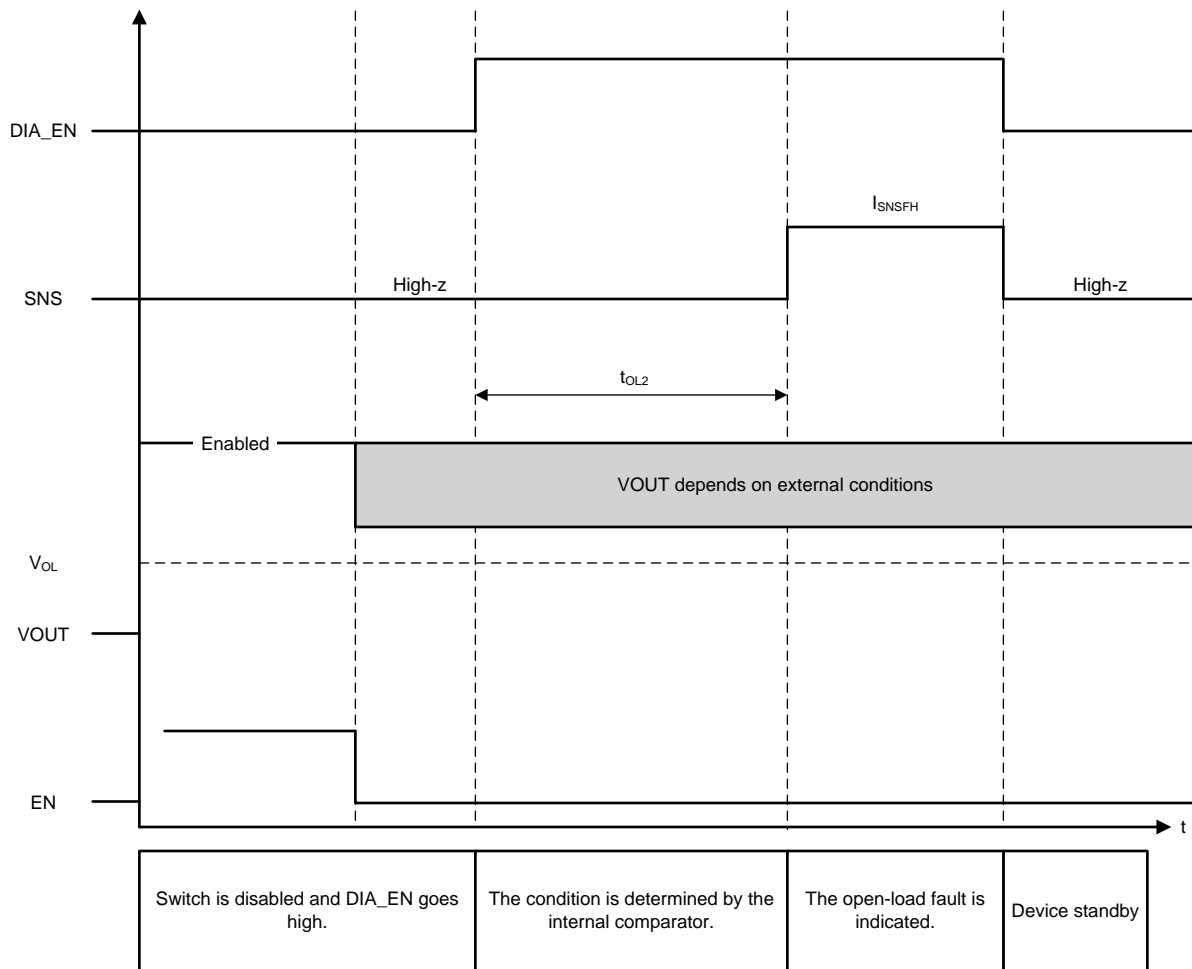

Figure 48. Open Load

9.3.2.2 SNS Output

The SNS output may be used to sense the load current, supply voltage, or device temperature. The SELx pins will select the desired sense signal. The sense circuit will provide a current that is proportional to the selected parameter. This current will be sourced into an external resistor to create a voltage that is proportional to the selected parameter. This voltage may be measured by an ADC or comparator.

To ensure accurate sensing measurement, the sensing resistor should be connected to the same ground potential as the μ C ADC.

The SNS Output includes an internal clamp, V_{SNSclamp}. This clamp is designed to prevent a high voltage at the SNS output and the ADC input.

Table 2. Analog Sense Transfer Function

PARAMETER	TRANSFER FUNCTION
Load current	$I_{SNSI} = I_{OUT} / 4600$
Supply voltage ⁽¹⁾	$I_{SNSV} = (V_{BB}) \times dI_{SNSV} / dV$
Device temperature	$I_{SNSST} = (T_J - 25^\circ\text{C}) \times dI_{SNSST} / dT + 0.85$

(1) Voltage potential between the V_{BB} pin and the GND pin.

The SNS output will also be used to indicate system faults. I_{SNS} will go to the predefined level, I_{SNSFH} , when there is a fault. This level is defined in the electrical specifications.

9.3.2.2.1 R_{SNS} Value

The following factors should be considered when selecting the R_{SNS} value:

- Current sense ratio
- Largest and smallest diagnosable load current
- Full-scale voltage of the ADC
- Resolution of the ADC

For an example of selecting R_{SNS} value, reference [Selecting the \$R_{SNS}\$ Value](#) in the applications section of this data sheet.

9.3.2.2.1.1 High Accuracy Load Current Sense

In many automotive modules, it is required that the high-side switch provide diagnostic information about the downstream load. With more complex loads, high accuracy sensing is required. A few examples follow:

- **LED Lighting:** In many architectures, the Body Control Module must be compatible with both incandescent bulbs and also LED modules. The bulb may be relatively simple to diagnose. However, the LED module will consume less current and also can include multiple LED strings in parallel. The same BCM is used in both cases, so the high-side switch must be able to accurately diagnose both load types.
- **Solenoid Protection:** Often solenoids are precisely controlled by low-side switches. However, in a fault event, the low-side switch cannot disconnect the solenoid from the power supply. A high-side switch can be used to continuously monitor several solenoids. If the system current becomes higher than expected, the high-side switch can disable the module.

9.3.2.2.1.2 SNS Output Filter

To achieve the most accurate current sense value, it is recommended to apply filtering to the SNS output. There are two methods of filtering:

- Low-Pass RC filter between the SNS pin and the ADC input. This filter is illustrated in [Figure 54](#) and typical values for the resistor and capacitor are given. The designer should select a C_{SNS} capacitor value based on system requirements. A larger value will provide improved filtering. A smaller value will allow for faster transient response.
- The ADC and microcontroller can also be used for filtering. It is recommended that the ADC collects several measurements of the SNS output. The median value of this data set should be considered as the most accurate result. By performing this median calculation, the microcontroller is able to filter out any noise or outlier data.

9.3.2.3 \overline{ST} Pin

The \overline{ST} pin is an open-drain output. The pin indicates the status of the switch channel. The output is high-z when there is no fault condition. The output is pulled low when there is a fault condition.

9.3.2.4 Fault Indication and SNS Mux

The following faults will be communicated via the SNS and \overline{ST} outputs:

- Switch shutdown, due to:
 - Thermal Shutdown
 - Current limit
 - Energy limit
- Active current limiting
- Open-Load / V_{OUT} shorted-to-battery

Open-load / Short-to-battery are not indicated while the switch is enabled (though these conditions can be detected via the sense current). Hence, if there is a fault indication corresponding to an enabled channel, then it must be either switch shutdown or active current limiting.

The SNS pin will only indicate the fault if the $SELx = 00$. Switch shutdown fault indication will occur on the \overline{ST} pin regardless of the $SELx$ pins; however, OL/STB fault indication is only available when the $SELx = 00$.

Table 3. SNS Mux

INPUTS				OUTPUTS	
DIA_EN	SEL1	SEL2	FAULT DETECT ⁽¹⁾	SNS	ST
0	X	X	0	High-z	High-z
0	X	X	1	High-z	Pull low
1	0	0	0	Load current	High-z
1	0	1	0	Not Used	Not Used
1	1	0	0	Device temperature	High-z
1	1	1	0	Supply voltage	High-z
1	0	0	1	I _{SNSFH}	Pull low
1	0	1	1	Not Used	Not Used
1	1	0	1	Device temperature	Pull low
1	1	1	1	Supply voltage	Pull low

- (1) Fault Detect encompasses the below conditions:
 (a) Switch shutdown and waiting for retry
 (b) Active current limiting
 (c) OL / STB

9.3.2.5 Resistor Sharing

Multiple high-side switch channels may use the same SNS resistor as shown in Figure 49 below. This reduces the total number of passive components in the system and the number of ADC terminals that are required of the microcontroller.

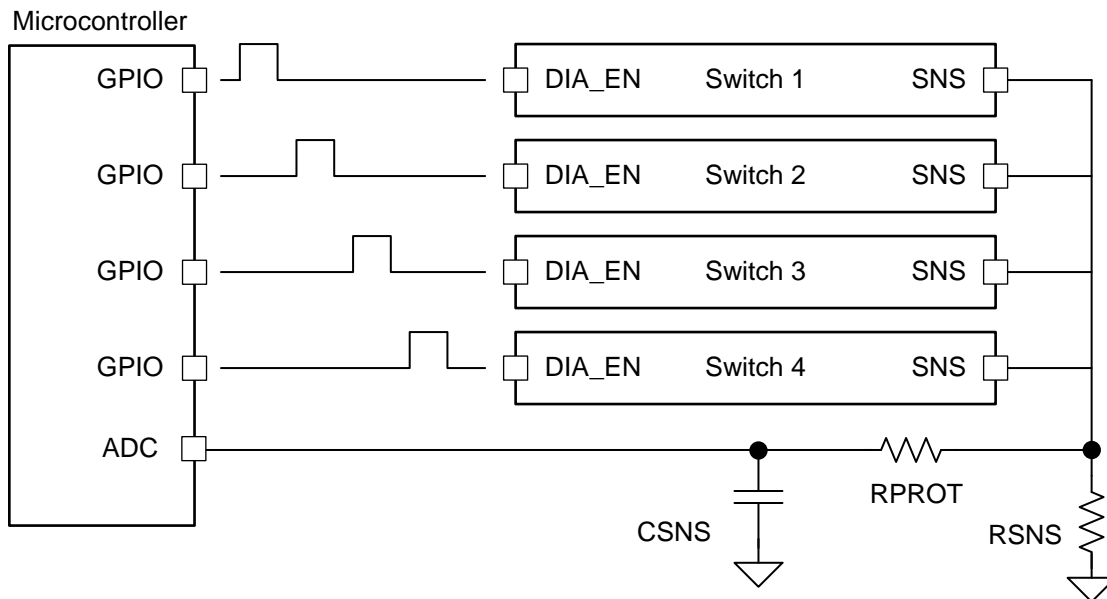

Figure 49. Sharing R_{SNS} Among Multiple Devices

9.3.2.6 High-Frequency, Low Duty-Cycle Current Sensing

Some applications will operate with a high-frequency, low duty-cycle PWM. Such applications require fast settling of the SNS output. For example, a 250 Hz, 5% duty cycle PWM will have an on-time of only 200 μs. The microcontroller ADC may sample the SNS signal after the defined settling time, t_{SNSION3}.

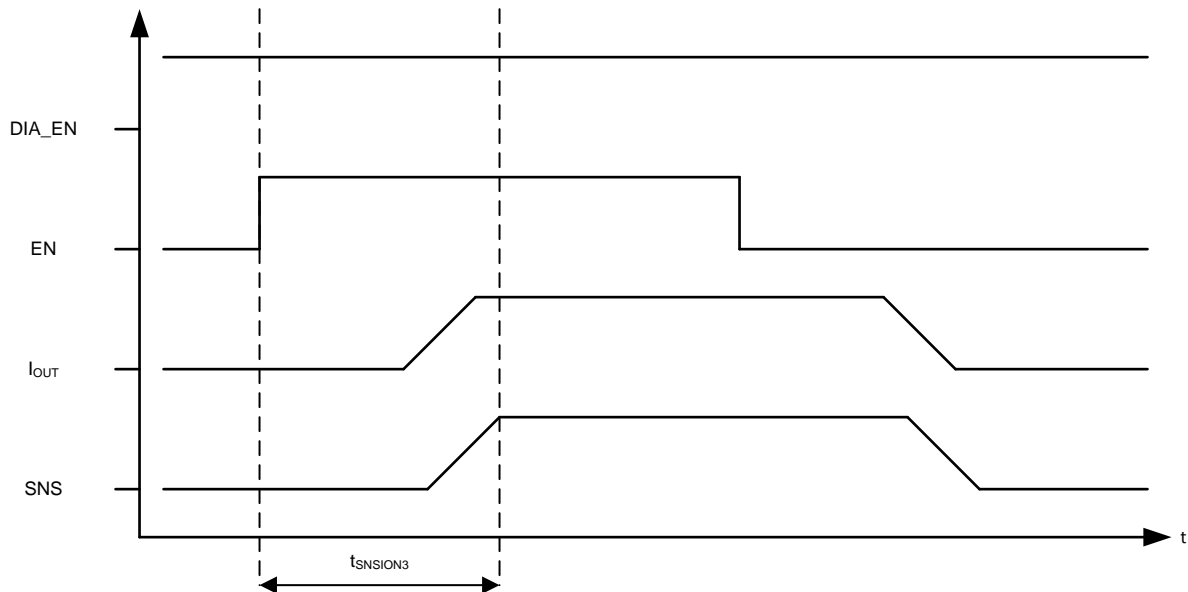
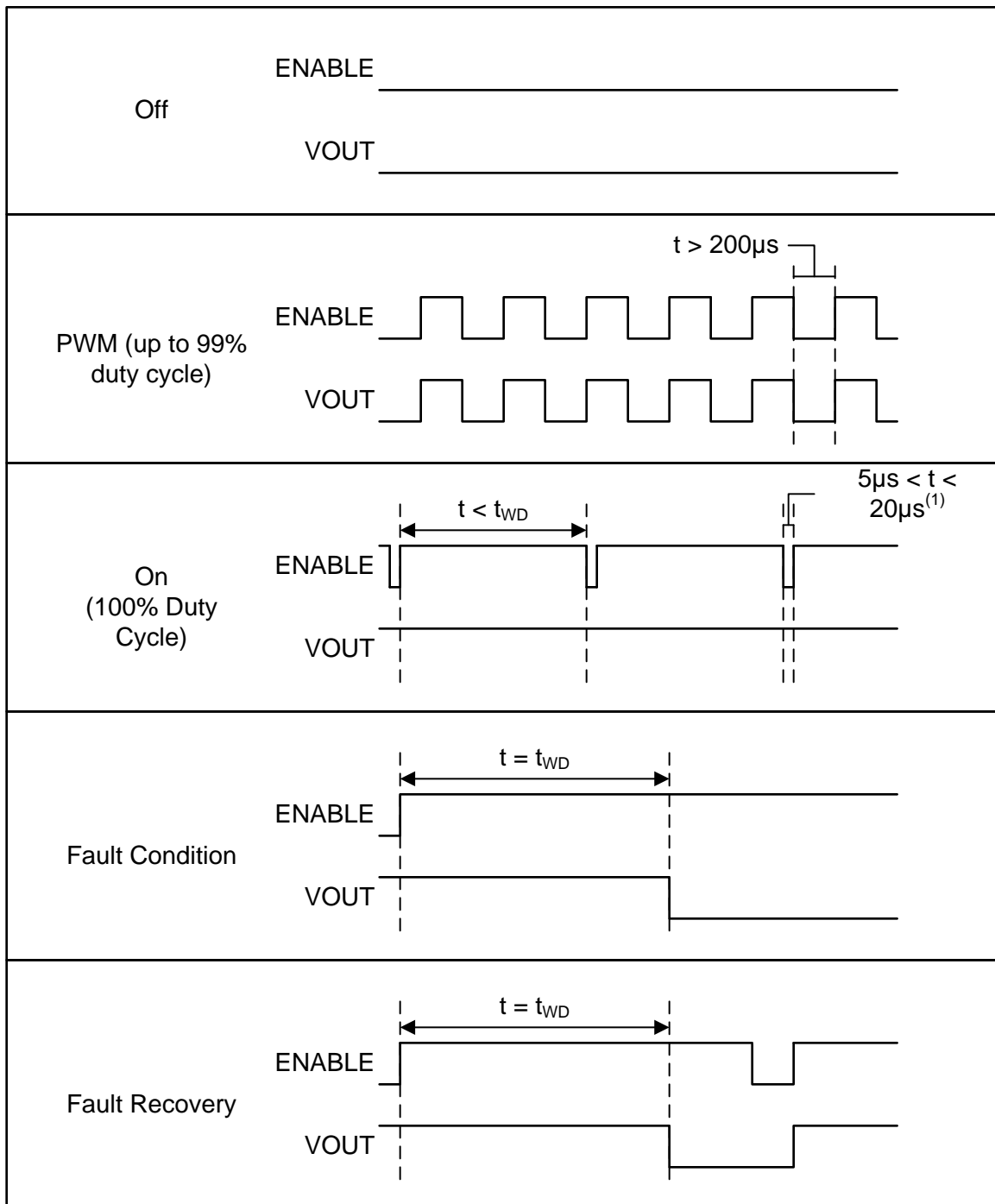

Figure 50. Current Sensing in Low-Duty Cycle Applications

9.3.3 Enable Watchdog

For some automotive applications, it is necessary to continuously verify that there is valid communication between the microcontroller and the switch enable pin. The purpose of this is to protect against possible communication faults (for example, microcontroller failure). The TPS1HA08-Q1 includes an optional watchdog feature which continuously polls the enable pin. Note that this feature is only activated for device version E, so the below information is only applicable to version E.

To use the watchdog feature, the microcontroller should apply a PWM to the switch enable pin. If this PWM is not present (EN is high continuously for $\geq t_{WD}$) the switch will automatically be disabled. The watchdog timer is reset on the rising edge of EN. The fault indications are cleared upon the falling edge of EN. The following figure illustrates how the switch will respond to the EN PWM.



The watchdog feature requires that a PWM is applied to the switch enable pin. To maintain V_{OUT} at 100% duty cycle, the microcontroller should periodically apply a short pulse to the enable pin. This short pulse will reset the watchdog timer, but will not cause the switch to turn-off. The pulse must be $>5\mu\text{s}$ to ensure that it is recognized by the device. There is no upper limit on the pulse width; however, if the pulse is longer than $20\mu\text{s}$, the switch may start to transition from enabled to disabled.

Figure 51. Enable Watchdog - Overview

Figure 52 illustrates the behavior of the watchdog feature.

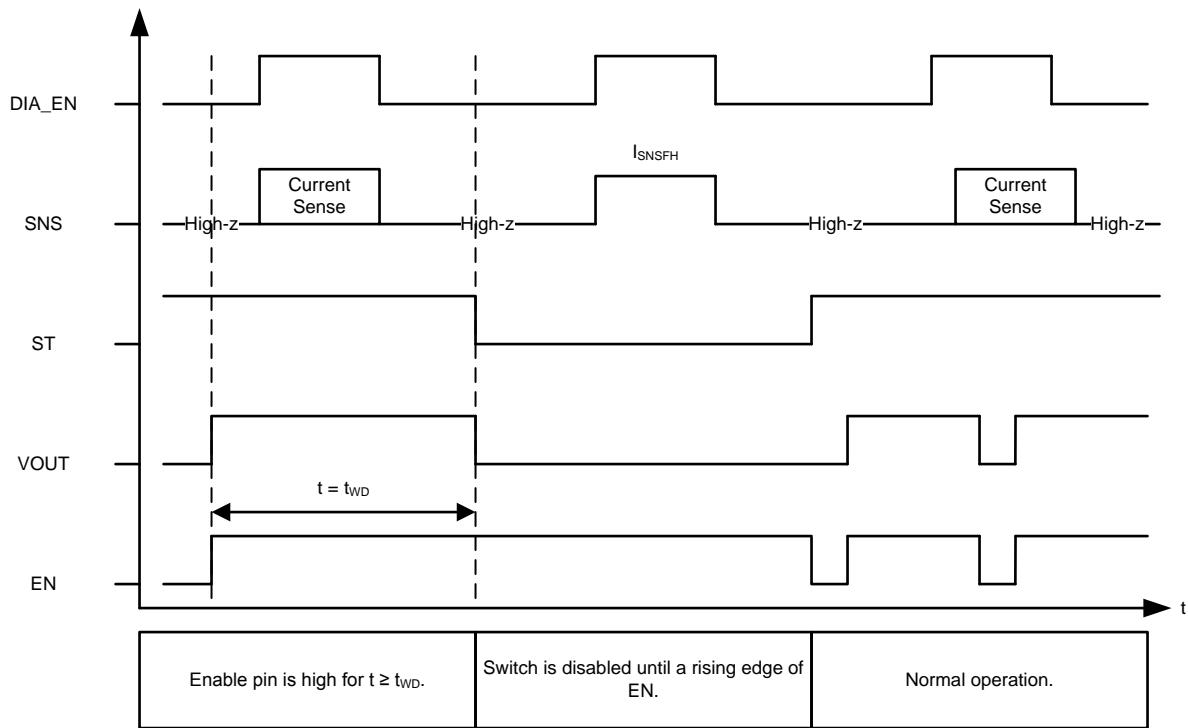

Figure 52. Enable Watchdog Timing Diagram

9.4 Device Functional Modes

9.4.1 Off

Off state occurs when the device is not powered.

9.4.2 Standby

Standby state is a low-power mode used to reduce power consumption to the lowest level. Diagnostic capabilities are not available in Standby mode.

9.4.3 Diagnostic

Diagnostic state may be used to perform diagnostics while the switch is disabled.

9.4.4 Standby Delay

The Standby Delay state is entered when EN and DIA_EN are low. After t_{STBY} , if the EN and DIA_EN pins are still low, the device will go to Standby State.

9.4.5 Active

In Active state, the switch is enabled. The diagnostic functions may be turned on or off during Active state.

9.4.6 Fault

The Fault state is entered if a fault shutdown occurs (thermal shutdown, current limit, energy limit). After all faults are cleared, the LATCH pin is low, and the retry timer has expired, the device will transition out of Fault state. If the Enable pin is high, the switch will re-enable. If the Enable pin is low, the switch will remain off.

Device Functional Modes (continued)

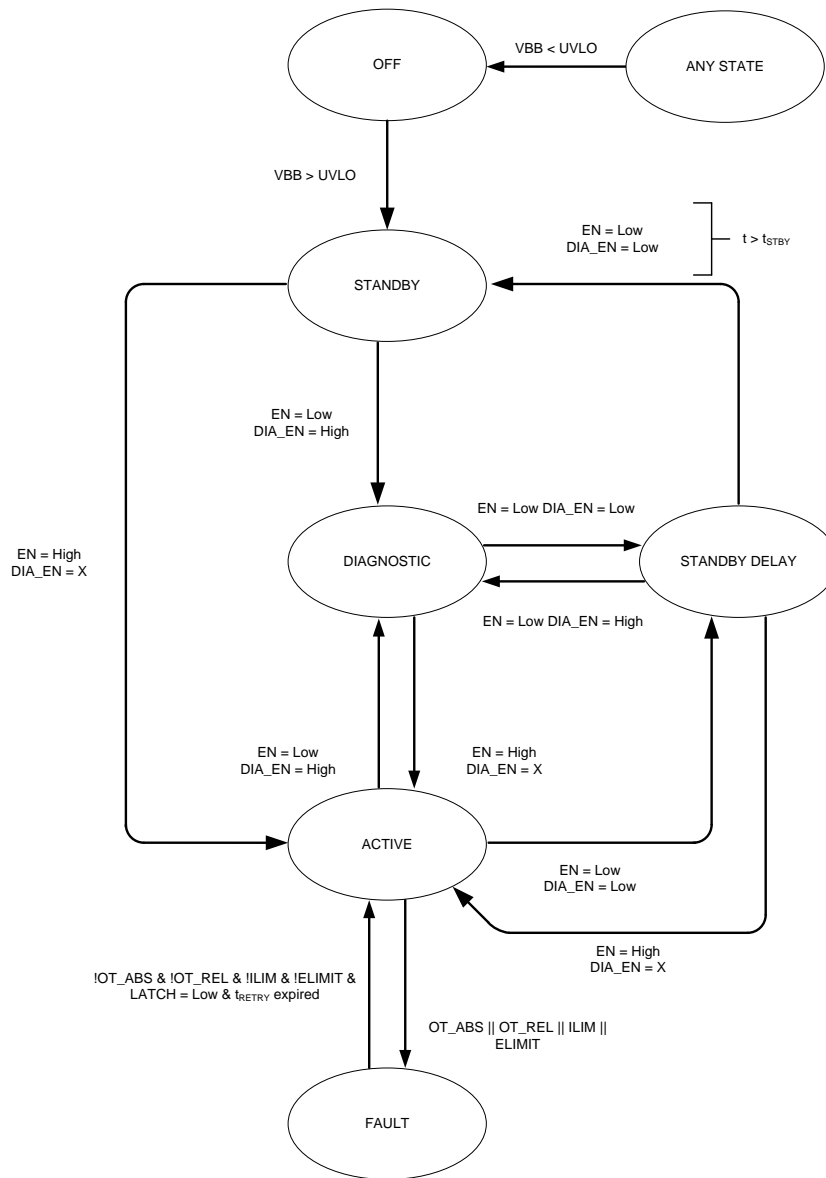

Figure 53. State Diagram

10 Application and Implementation

NOTE

Information in the following applications sections is not part of the TI component specification, and TI does not warrant its accuracy or completeness. TI's customers are responsible for determining suitability of components for their purposes. Customers should validate and test their design implementation to confirm system functionality.

10.1 Application Information

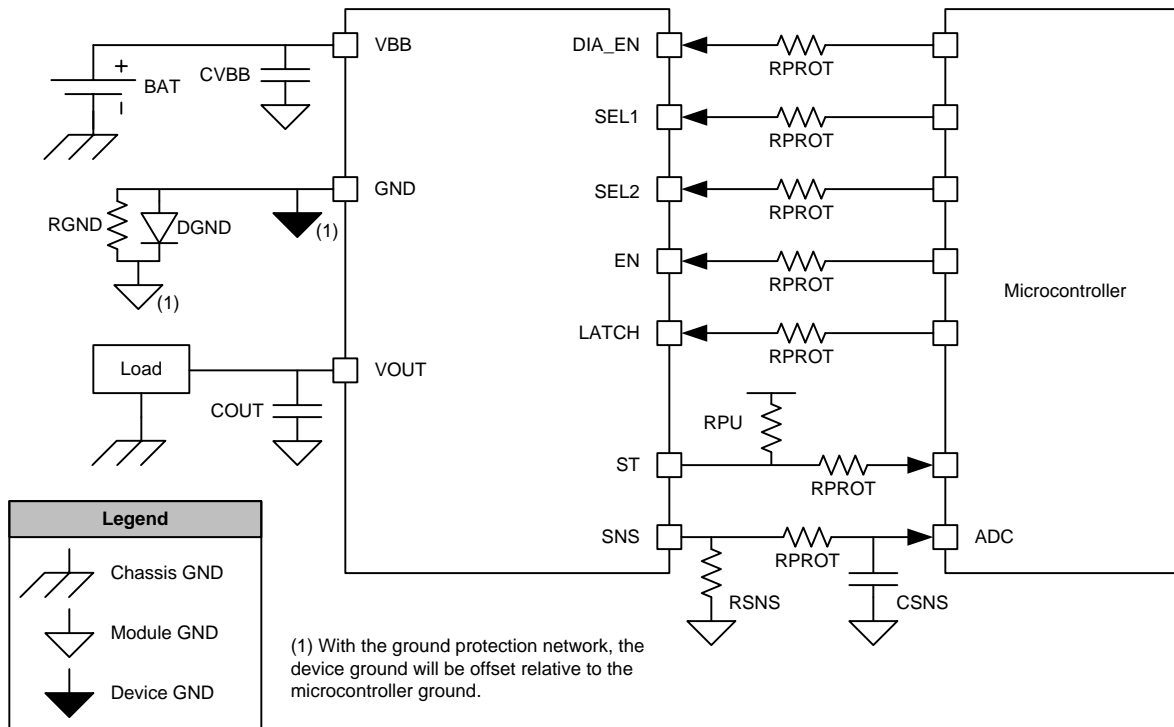

With the ground protection network, the device ground will be offset relative to the microcontroller ground.

Figure 54. System Diagram

Table 4. Recommended External Components

COMPONENT	TYPICAL VALUE	PURPOSE
R_{PROT}	15 k Ω	Protect microcontroller and device I/O pins
R_{SNS}	1 k Ω	Translate the sense current into sense voltage
R_{PU}	10 k Ω	Provide pull-up source for open-drain output
C_{SNS}	100 pF - 10 nF	Low-pass filter for the ADC input
R_{GND}	4.7 k Ω	Stabilize GND potential during turn-off of inductive load
D_{GND}	BAS21 Diode	Protects device during reverse battery
C_{VBB}	220 nF to Device GND	Filtering of voltage transients (for example, ESD, ISO7637-2) and improved emissions
	100 nF to Module GND	Stabilize the input supply and filter out low frequency noise.
C_{OUT}	22 nF	Filtering of voltage transients (for example, ESD, ISO7637-2)

10.1.1 Ground Protection Network

As discussed in the section regarding Reverse Battery, D_{GND} may be used to prevent excessive reverse current from flowing into the device during a reverse battery event. Additionally, R_{GND} is placed in parallel with D_{GND} if the switch is used to drive an inductive load. The ground protection network (D_{GND} and R_{GND}) may be shared amongst multiple high-side switches.

A minimum value for R_{GND} may be calculated by using the absolute maximum rating for I_{GND} . During the reverse battery condition, $I_{GND} = V_{BB} / R_{GND}$:

$$R_{GND} \geq V_{BB} / I_{GND}$$

- Set $V_{BB} = -13.5 \text{ V}$
- Set $I_{GND} = -50 \text{ mA}$ (absolute maximum rating)

$$R_{GND} \geq -13.5 \text{ V} / -50 \text{ mA} = 270 \ \Omega \quad (1)$$

In this example, it is found that R_{GND} must be at least $270 \ \Omega$. It is also necessary to consider the power dissipation in R_{GND} during the reverse battery event:

$$P_{RGND} = V_{BB}^2 / R_{GND} \quad (2)$$

$$P_{RGND} = (13.5 \text{ V})^2 / 270 \ \Omega = 0.675 \text{ W}$$

In practice, R_{GND} may not be rated for such a high power. In this case, a larger resistor value should be selected.

10.1.2 Interface With Microcontroller

The ground protection network will cause the device ground to be at a higher potential than the module ground (and microcontroller ground). This offset will impact the interface between the device and the microcontroller.

Logic pin voltage will be offset by the forward voltage of the diode. For input pins (for example, EN), the designer must consider the V_{IH} specification of the switch and the V_{OH} specification of the microcontroller. For a system that *does not* include D_{GND} , it is required that $V_{OH} > V_{IH}$. For a system that *does* include D_{GND} , it is required that $V_{OH} > (V_{IH} + V_F)$. V_F is the forward voltage of D_{GND} .

For use of the status pin, ST, a similar consideration is necessary. The designer must consider the $V_{OL, ST}$ specification and the V_{IL} specification of the microcontroller. For a system that includes D_{GND} , it is required that $V_{OL, ST} + V_F < V_{IL, \mu C}$.

The sense resistor, R_{SNS} , should be terminated to the microcontroller ground. In this case, the ADC can accurately measure the SNS signal even if there is an offset between the microcontroller ground and the device ground.

10.1.3 I/O Protection

R_{PROT} is used to protect the microcontroller I/O pins during system-level voltage transients such as ISO pulses or reverse battery. A large resistance value ensures that current through the pin is limited to a safe level.

10.1.4 Inverse Current

Inverse current occurs when $0 \text{ V} < V_{BB} < V_{OUT}$. In this case, current may flow from V_{OUT} to V_{BB} . Inverse current cannot be caused by a purely resistive load. However, a capacitive or inductive load can cause inverse current. For example, if there is a significant amount of load capacitance and the V_{BB} node has a transient droop, V_{OUT} may be greater than V_{BB} .

TPS1HA08-Q1 will not detect inverse current. When the switch is enabled, inverse current will pass through the switch. When the switch is disabled, inverse current may pass through the MOSFET body diode. The device will continue operating in the normal manner during an inverse current event.

10.1.5 Loss of GND

The ground connection may be lost either on the device level or on the module level. If the ground connection is lost, both switches will be disabled. If the switch was already disabled when the ground connection was lost, the switch will remain disabled. When the ground is reconnected, normal operation will resume.

10.1.6 Automotive Standards

10.1.6.1 ISO7637-2

TPS1HA08-Q1 is tested according to the ISO7637-2:2011 (E) standard. The test pulses are applied both with the switches enabled and disabled. The test setup includes only the DUT and minimal external components: C_{VBB} , C_{OUT} , D_{GND} , and R_{GND} .

Status II is defined in ISO 7637-1 Function Performance Status Classification (FPSC) as: “The function does not perform as designed during the test but returns automatically to normal operation after the test”.

Table 5. ISO7637-2:2011 (E) Results

TEST PULSE	TEST PULSE SEVERITY LEVEL WITH STATUS II FUNCTIONAL PERFORMANCE		MINIMUM NUMBER OF PULSES OR TEST TIME	BURST CYCLE / PULSE REPETITION TIME	
	LEVEL	US		MIN	MAX
1	IV	–150 V	500 pulses	0.5 s	--
2a	III	+55 V	500 pulses	0.20	5 s
2b	IV	+10 V	10 pulses	0.5 s	5 s
3a	III	–165 V	1 hour	90 ms	100 ms
3b	III	+112 V	1 hour	90 ms	100 ms

10.1.6.2 AEC – Q100-012 Short Circuit Reliability

The TPS1HA08-Q1 is tested according to the AEC - Q100-012 Short Circuit Reliability standard. This test is performed to demonstrate the robustness of the device against V_{OUT} short-to-ground events. Test results are summarized in [Table 6](#). For further details, refer to the AEC - Q100-012 standard document or TI's [Short Circuit Reliability Test for Smart Power Switches](#) application report.

Test conditions:

- LATCH = 0 V
- $T_A = -40^\circ\text{C}$
- 10 units from 3 separate lots for a total of 30 units
- $L_{supply} = 5 \mu\text{H}$, $R_{supply} = 10 \text{ m}\Omega$
- $V_{BB} = 14 \text{ V}$

Test procedure:

- Parametric data is collected on each unit pre-stress
- Each unit is enabled into a short circuit with the required short circuit cycles or duration as specified
- Parametric data is re-collected on each unit post-stress to verify that no parametric shift is observed

The cold repetitive test is run at -40°C which is the worst case condition for the TPS1HA08-Q1. The current limit threshold is highest at cold temperature; hence, the short-circuit pulse contains more energy at cold temperature. The cold repetitive test refers to the device being given time to cool down between pulses, within than being run at a cold temperature. The load short circuit is the worst case situation, since the energy stored in the cable inductance can cause additional harm. The fast response of the device ensures current limiting occurs quickly and at a current close to the load short condition. In addition, the hot repetitive test is performed as well.

Table 6. AEC - Q100-012 Test Results

TEST	LOCATION OF SHORT	DEVICE VERSION	NO. OF CYCLES	NO. OF UNITS	NO. OF FAILS
Cold Repetitive - Long Pulse	Load Short Circuit, $L_{short} = 5 \mu\text{H}$, $R_{short} = 100 \text{ m}\Omega$, $T_A = -40^\circ\text{C}$	D	200 k	30	0
Hot Repetitive - Long Pulse	Terminal Short Circuit, $L_{short} = 5 \mu\text{H}$, $R_{short} = 100 \text{ m}\Omega$, $T_A = 25^\circ\text{C}$	D	100 hours	30	0

10.1.7 Thermal Information

When outputting current, the TPS1HA08-Q1 will heat up due to the power dissipation. Figure 55 shows the transient thermal impedance curve that can be used to determine the device temperature during 1 W pulse of a given length.

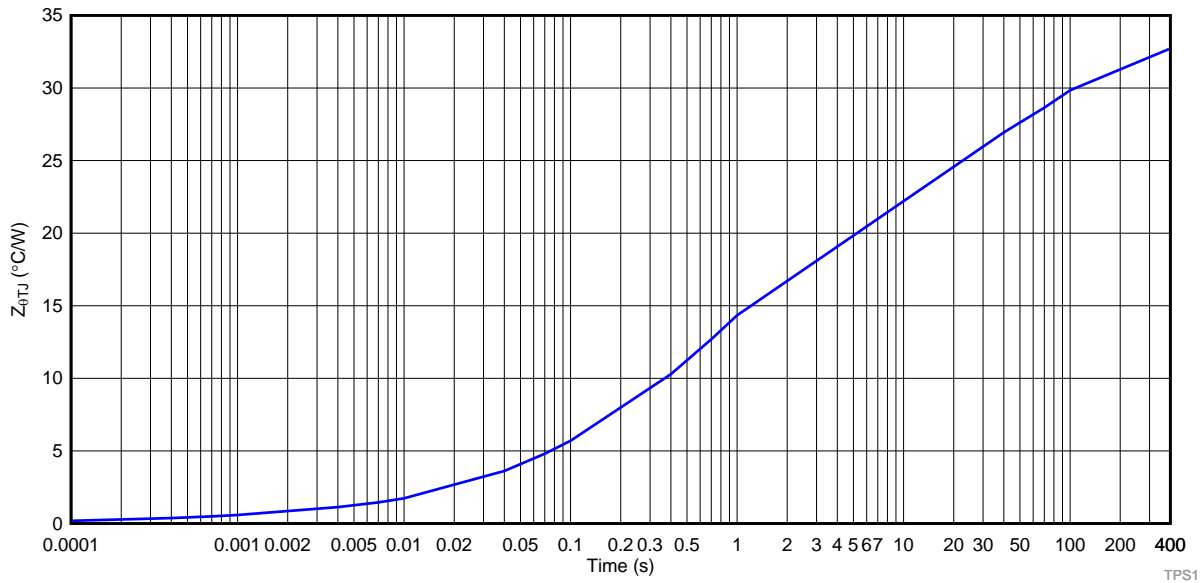

Figure 55. Transient Thermal Impedance

10.2 Typical Application

This application example demonstrates how the TPS1HA08-Q1 device can be used to power resistive heater loads as in seat heaters. Figure 56 shows a typical application where the load is a resistive seat heater. This document highlights the basics of this type of application, however for a more detailed discussion reference *TI's Smart Power Switch Seat Heater Reference Design*.

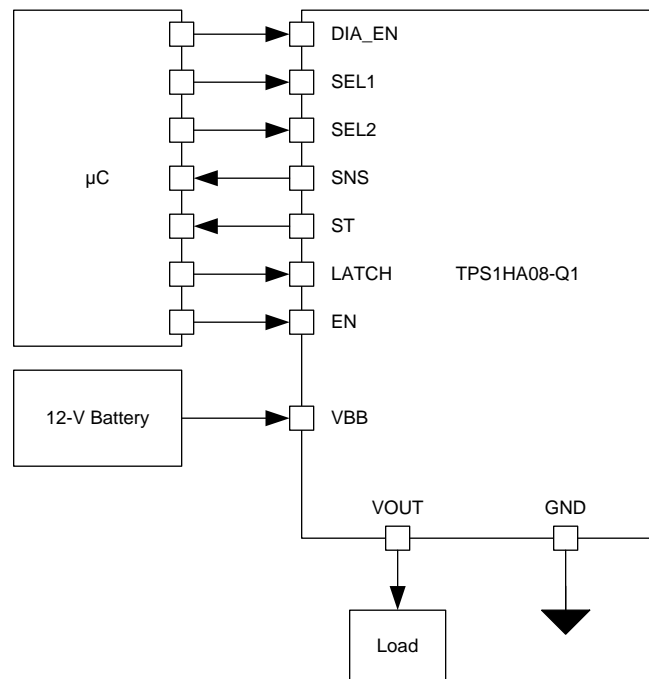

Figure 56. Block Diagram for Powering Heater Loads

Typical Application (continued)

10.2.1 Design Requirements

For this design example, use the input parameters shown in [Table 7](#).

Table 7. Design Parameters

DESIGN PARAMETER	EXAMPLE VALUE
V_{BB}	12.8 V
Heater Load	90 W max
Load Current Sense	100 mA to 20 A
Ambient temperature	85°C
$R_{\theta JA}$	32.8°C/W (depending on PCB)

10.2.2 Detailed Design Procedure

10.2.2.1 Thermal Considerations

The DC current under maximum load power condition will be around 7.03 A. Power dissipation in the switch is calculated in [Equation 3](#). R_{ON} is assumed to be 20 mΩ because this is the maximum specification. In practice, R_{ON} will be lower.

$$P_{FET} = I^2 \times R_{ON} \quad (3)$$

$$P_{FET} = (7.03 \text{ A})^2 \times 20 \text{ m}\Omega = 0.988 \text{ W} \quad (4)$$

The junction temperature of the device can be calculated using [Equation 5](#) and the $R_{\theta JA}$ value from the [Specifications](#) section.

$$T_J = T_A + R_{\theta JA} \times P_{FET} \quad (5)$$

$$T_J = 85^\circ\text{C} + 32.8^\circ\text{C/W} \times 0.988 \text{ W} = 117.4^\circ\text{C}$$

The maximum junction temperature rating for TPS1HA08-Q1 device is $T_J = 150^\circ\text{C}$. Based on the above example calculation, the device temperature will stay below the maximum rating.

10.2.2.2 Diagnostics

If the resistive heating load is disconnected (heater malfunction), an alert is desired. Open-load detection can be performed in the switch-enabled state via the current sense feature of the TPS1HA08-Q1 device. Alternatively, under open load condition in off-state with diagnostics enabled, the current in the SNS pin will be the fault current and the can be detected from the sense voltage measurement.

10.2.2.2.1 Selecting the R_{ISNS} Value

[Table 8](#) shows the requirements for the load current sense in this application. The K_{SNS} value is specified for the device and can be found in the [Specifications](#) section.

Table 8. R_{SNS} Calculation Parameters

PARAMETER	EXAMPLE VALUE
Current Sense Ratio (K_{SNS})	4600
Largest diagnosable load current	20 A
Smallest diagnosable load current	50 mA
Full-scale ADC voltage	5 V
ADC resolution	10 bit

The load current measurement requirements of 20 A ensures that current can be sensed up to the 20 A current limit, while the low level of 100 mA allows for accurate measurement of low load currents.

The R_{SNS} resistor value should be selected such that the largest diagnosable load current puts V_{SNS} at about 90% of the ADC full-scale. With this design, any ADC value above 90% can be considered a fault. Additionally, the R_{SNS} resistor value should ensure that the smallest diagnosable load current does not cause V_{SNS} to fall below 1 LSB of the ADC. With the given example values, a 1-kΩ sense resistor satisfies both requirements shown in [Table 9](#).

Table 9. V_{SNS} Calculation

LOAD (A)	SENSE RATIO	I_{SNS} (mA)	R_{SNS} (Ω)	V_{SNS} (V)	% OF 5-V ADC
0.050	4600	0.011	1000	0.011	0.22%
20.000	4600	4.348	1000	4.348	87%

10.2.3 Application Curves

Figure 57 shows the behavior of the TPS1HA08-Q1 in this application when the MCU provides an enable pulse to beginning heating the resistive element. Shortly after the EN pin goes high, the load current begins to flow and the SNS pin measures the output current.

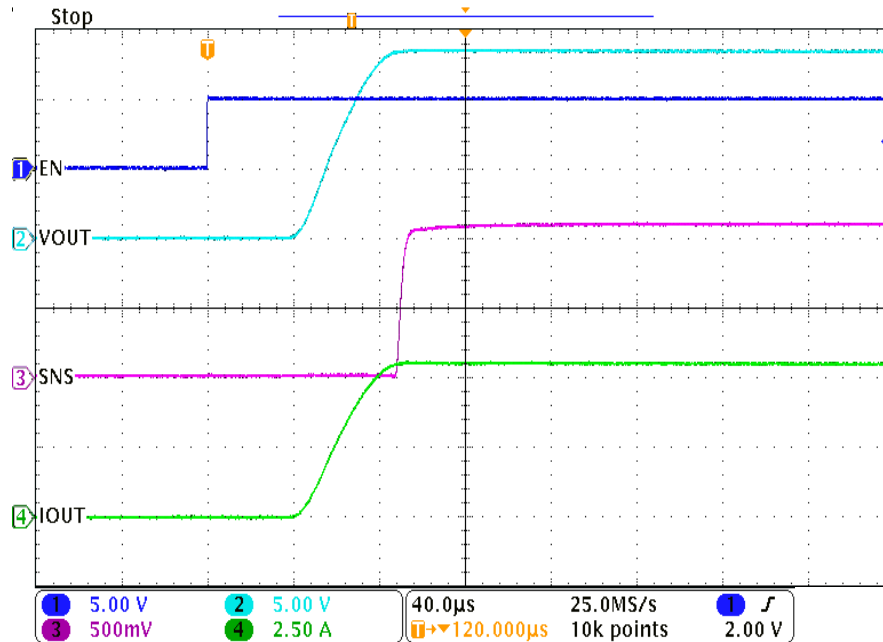

Figure 57. Heater Turn-on Time

By measuring the voltage on the SNS pin, the TPS1HA08-Q1 can communicate back to the system MCU what the load current is. Figure 58 shows that when the seat heater approaches full load and I_{OUT} jumps from a low load current of 1 A up to a 5 A load current, the load step is mirrored on the SNS pin.

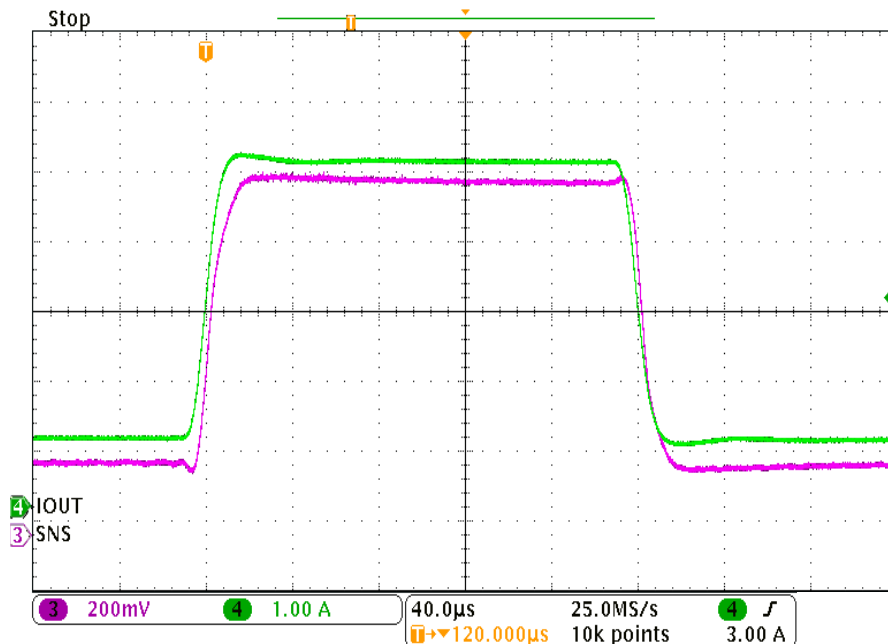

Figure 58. SNS Response During Heater Load Step

One common concern in these type of applications is that the heating element can accidentally lose connection, creating an open load situation. In this case, it is ideal for the TPS1HA08-Q1 to recognize that the load has been removed and report a FLT to the MCU. Figure 59 shows the behavior of the TPS1HA08-Q1 when there is no load attached. As soon as the DIAG_EN pin is engaged, the SNS output goes high and the ST output engages low. By monitoring these pins, the MCU can recognize there is a fault and notify the user that maintenance is required.

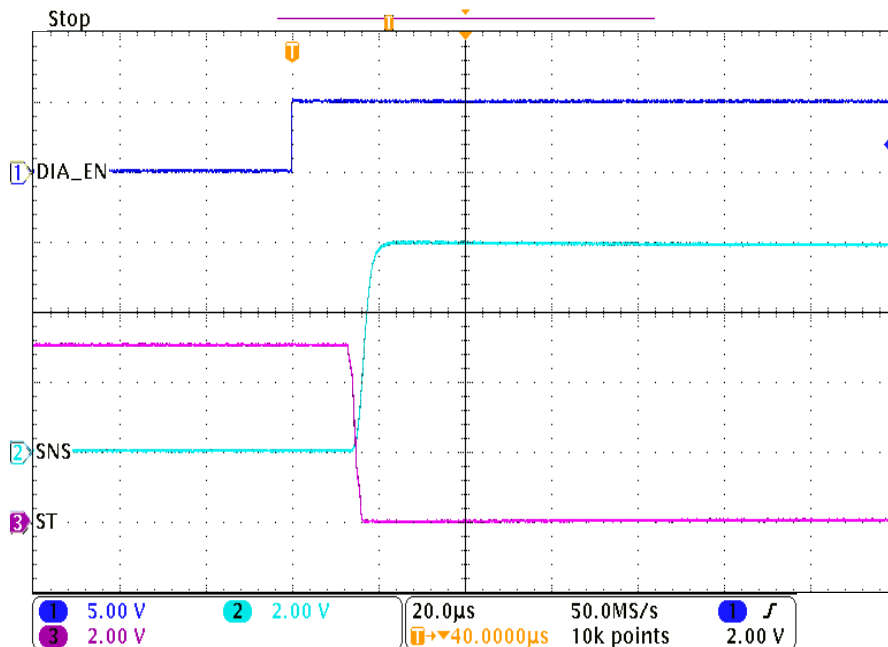

Figure 59. Open Load Detection If Heating Element is Missing

Importantly, the TPS1HA08-Q1 will also protect the system in the event of a short-circuit. Figure 60 shows the behavior of the device if it is enabled into a short circuit condition. If this is using the device option C, the current will be clamped to the current limit I_{CL} until it hits an over temperature event, at which point it will shut down. In this way, the system is protected from unchecked overcurrent in the event of a short circuit.

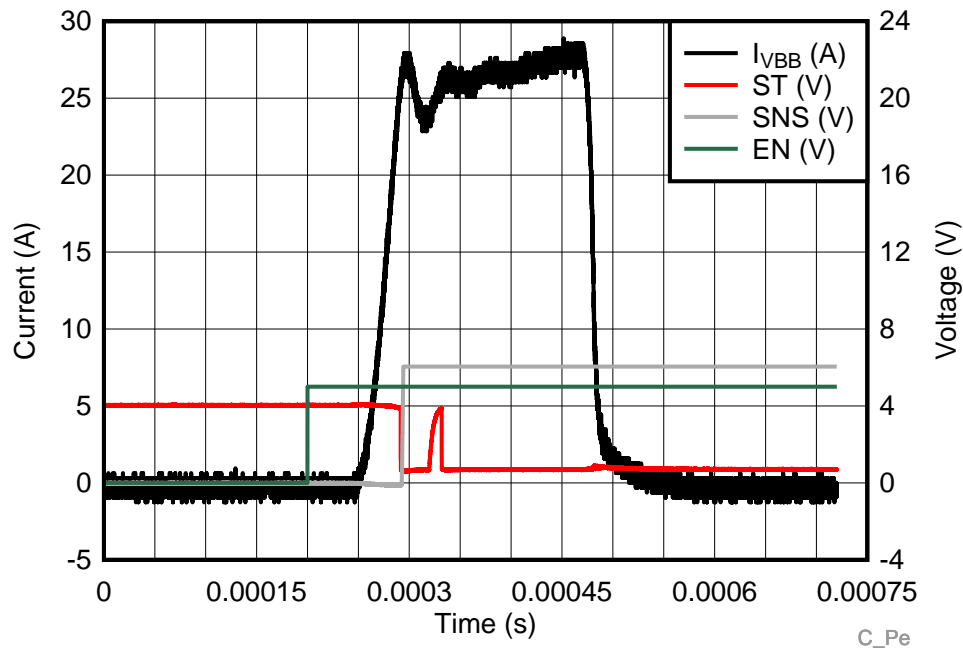

Figure 60. Overcurrent Behavior During Short Circuit Event

11 Power Supply Recommendations

The TPS1HA08-Q1 is designed to operate in a 12-V automotive system. The nominal supply voltage range is 8 V to 18 V. The device is also designed to withstand voltage transients beyond this range. When operating outside of the nominal voltage range, the device will exhibit normal functional behavior. However, parametric specifications may not be guaranteed.

Table 10. Operating Voltage Range

V _{BB} Voltage Range	Note
3 V to 8 V	Transients such as cold crank and start-stop, functional operation guaranteed but some parametric specifications may not apply. The device is completely short-circuit protected up to 125°C
8 V to 18 V	Nominal supply voltage, all parametric specifications apply. The device is completely short-circuit protected up to 125°C
18 V to 40 V	Transients such as jump-start and load-dump, functional operation guaranteed but some parametric specifications may not apply

12 Layout

12.1 Layout Guidelines

To achieve optimal thermal performance, connect the exposed pad to a large copper pour. On the top PCB layer, the pour may extend beyond the pad dimensions as shown in the example below. In addition to this, it is recommended to also have a V_{BB} plane either on one of the internal PCB layers or on the bottom layer. Vias should connect this plane to the top V_{BB} pour.

TPS1HA08-Q1 has 6 V_{OUT} pins. All V_{OUT} pins must be shorted together on the PCB. Additionally, the layout should ensure that the current path is symmetrical for both sides of the device. If the path is not symmetrical, there will be some imbalance in current spreading across the power FET. This can impact accuracy of the current sense measurement.

12.2 Layout Example

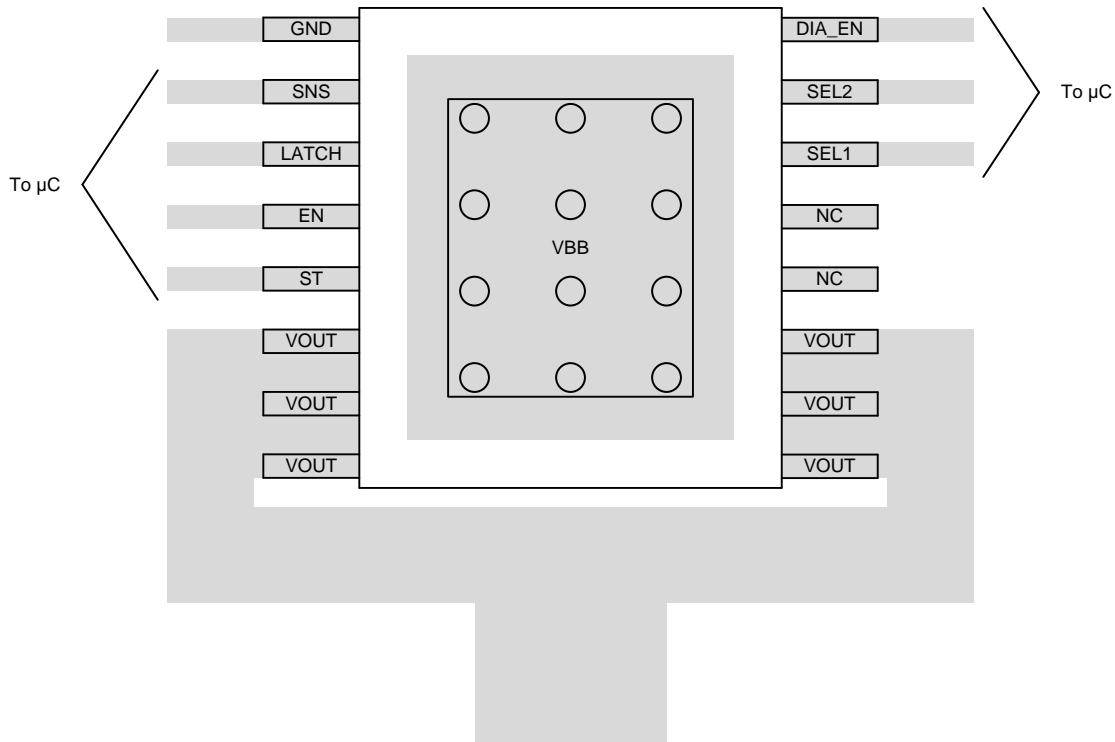

Figure 61. PWP Layout Example

13 Device and Documentation Support

13.1 Device Support

13.1.1 Related Documentation

For related documentation see the following:

- [TI's "How To Drive Inductive, Capacitive, and Lighting Loads with Smart High Side Switch"](#)
- [Short Circuit Reliability Test for Smart Power Switches](#)
- [TI's Smart Power Switch Seat Heater Reference Design](#)

13.2 Community Resources

The following links connect to TI community resources. Linked contents are provided "AS IS" by the respective contributors. They do not constitute TI specifications and do not necessarily reflect TI's views; see TI's [Terms of Use](#).

TI E2E™ Online Community *TI's Engineer-to-Engineer (E2E) Community*. Created to foster collaboration among engineers. At e2e.ti.com, you can ask questions, share knowledge, explore ideas and help solve problems with fellow engineers.

Design Support *TI's Design Support* Quickly find helpful E2E forums along with design support tools and contact information for technical support.

13.3 Trademarks

E2E is a trademark of Texas Instruments.

13.4 Electrostatic Discharge Caution



These devices have limited built-in ESD protection. The leads should be shorted together or the device placed in conductive foam during storage or handling to prevent electrostatic damage to the MOS gates.

13.5 Glossary

[SLYZ022](#) — *TI Glossary*.

This glossary lists and explains terms, acronyms, and definitions.

14 Mechanical, Packaging, and Orderable Information

The following pages include mechanical, packaging, and orderable information. This information is the most current data available for the designated devices. This data is subject to change without notice and revision of this document. For browser-based versions of this data sheet, refer to the left-hand navigation.

PACKAGING INFORMATION

Orderable Device	Status (1)	Package Type	Package Drawing	Pins	Package Qty	Eco Plan (2)	Lead/Ball Finish (6)	MSL Peak Temp (3)	Op Temp (°C)	Device Marking (4/5)	Samples
PTPS1HA08AQPWPRQ1	ACTIVE	HTSSOP	PWP	16	2000	TBD	Call TI	Call TI	-40 to 125		Samples
PTPS1HA08DQPWPRQ1	ACTIVE	HTSSOP	PWP	16	2000	TBD	Call TI	Call TI	-40 to 125		Samples
TPS1HA08AQPWPRQ1	ACTIVE	HTSSOP	PWP	16	2000	Pb-Free (RoHS Exempt)	CU NIPDAU	Level-3-260C-168HRS	-40 to 125	1HA08A	Samples
TPS1HA08AQPWPTQ1	ACTIVE	HTSSOP	PWP	16	250	Pb-Free (RoHS Exempt)	CU NIPDAU	Level-3-260C-168HRS	-40 to 125	1HA08A	Samples
TPS1HA08DQPWPRQ1	PREVIEW	HTSSOP	PWP	16	2000	Pb-Free (RoHS Exempt)	Call TI	Level-3-260C-168HRS	-40 to 125	1HA08D	

(1) The marketing status values are defined as follows:

ACTIVE: Product device recommended for new designs.

LIFEBUY: TI has announced that the device will be discontinued, and a lifetime-buy period is in effect.

NRND: Not recommended for new designs. Device is in production to support existing customers, but TI does not recommend using this part in a new design.

PREVIEW: Device has been announced but is not in production. Samples may or may not be available.

OBSOLETE: TI has discontinued the production of the device.

(2) **RoHS:** TI defines "RoHS" to mean semiconductor products that are compliant with the current EU RoHS requirements for all 10 RoHS substances, including the requirement that RoHS substance do not exceed 0.1% by weight in homogeneous materials. Where designed to be soldered at high temperatures, "RoHS" products are suitable for use in specified lead-free processes. TI may reference these types of products as "Pb-Free".

RoHS Exempt: TI defines "RoHS Exempt" to mean products that contain lead but are compliant with EU RoHS pursuant to a specific EU RoHS exemption.

Green: TI defines "Green" to mean the content of Chlorine (Cl) and Bromine (Br) based flame retardants meet JS709B low halogen requirements of <=1000ppm threshold. Antimony trioxide based flame retardants must also meet the <=1000ppm threshold requirement.

(3) MSL, Peak Temp. - The Moisture Sensitivity Level rating according to the JEDEC industry standard classifications, and peak solder temperature.

(4) There may be additional marking, which relates to the logo, the lot trace code information, or the environmental category on the device.

(5) Multiple Device Markings will be inside parentheses. Only one Device Marking contained in parentheses and separated by a "~" will appear on a device. If a line is indented then it is a continuation of the previous line and the two combined represent the entire Device Marking for that device.

(6) Lead/Ball Finish - Orderable Devices may have multiple material finish options. Finish options are separated by a vertical ruled line. Lead/Ball Finish values may wrap to two lines if the finish value exceeds the maximum column width.

Important Information and Disclaimer: The information provided on this page represents TI's knowledge and belief as of the date that it is provided. TI bases its knowledge and belief on information provided by third parties, and makes no representation or warranty as to the accuracy of such information. Efforts are underway to better integrate information from third parties. TI has taken and continues to take reasonable steps to provide representative and accurate information but may not have conducted destructive testing or chemical analysis on incoming materials and chemicals. TI and TI suppliers consider certain information to be proprietary, and thus CAS numbers and other limited information may not be available for release.

In no event shall TI's liability arising out of such information exceed the total purchase price of the TI part(s) at issue in this document sold by TI to Customer on an annual basis.

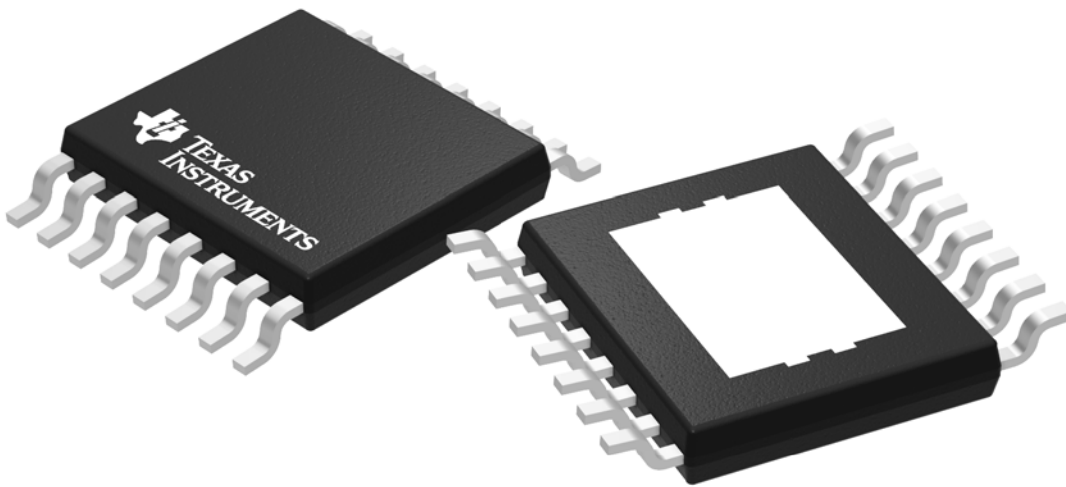

Images above are just a representation of the package family, actual package may vary.
Refer to the product data sheet for package details.

IMPORTANT NOTICE AND DISCLAIMER

TI PROVIDES TECHNICAL AND RELIABILITY DATA (INCLUDING DATASHEETS), DESIGN RESOURCES (INCLUDING REFERENCE DESIGNS), APPLICATION OR OTHER DESIGN ADVICE, WEB TOOLS, SAFETY INFORMATION, AND OTHER RESOURCES "AS IS" AND WITH ALL FAULTS, AND DISCLAIMS ALL WARRANTIES, EXPRESS AND IMPLIED, INCLUDING WITHOUT LIMITATION ANY IMPLIED WARRANTIES OF MERCHANTABILITY, FITNESS FOR A PARTICULAR PURPOSE OR NON-INFRINGEMENT OF THIRD PARTY INTELLECTUAL PROPERTY RIGHTS.

These resources are intended for skilled developers designing with TI products. You are solely responsible for (1) selecting the appropriate TI products for your application, (2) designing, validating and testing your application, and (3) ensuring your application meets applicable standards, and any other safety, security, or other requirements. These resources are subject to change without notice. TI grants you permission to use these resources only for development of an application that uses the TI products described in the resource. Other reproduction and display of these resources is prohibited. No license is granted to any other TI intellectual property right or to any third party intellectual property right. TI disclaims responsibility for, and you will fully indemnify TI and its representatives against, any claims, damages, costs, losses, and liabilities arising out of your use of these resources.

TI's products are provided subject to TI's Terms of Sale (www.ti.com/legal/termsofsale.html) or other applicable terms available either on ti.com or provided in conjunction with such TI products. TI's provision of these resources does not expand or otherwise alter TI's applicable warranties or warranty disclaimers for TI products.

Mailing Address: Texas Instruments, Post Office Box 655303, Dallas, Texas 75265
Copyright © 2018, Texas Instruments Incorporated