

## TPA6138A2 DirectPath™ Headphone Driver With Adjustable Gain

### 1 Features

- Stereo DirectPath™ Headphone Amplifier
  - 40 mW Into 32 Ω With 3.3-V Supply
- Low THD+N < 0.01% at 10 mW Into 32 Ω
- High SNR, >90 dB
- Differential Input and Single-Ended Output
- Adjustable Gain by External Gain-Setting Resistors
- Configurable as a Second-Order Low-Pass Filter
  - Ideal for PWM Audio Sources
- Low DC Offset, <1 mV
- Ground-Referenced Outputs Eliminate DC-Blocking Capacitors
  - Reduce Board Area
  - Reduce Component Cost
  - Improve THD+N Performance
  - No Degradation of Low-Frequency Response Due to Output Capacitors
- Short-Circuit Protection
- Click- and Pop-Reduction Circuitry
- External Undervoltage Mute
- Active Mute Control for Pop-Free Audio On/Off Control
- Space-Saving TSSOP Package

### 2 Applications

- LCD and PDP TV
- Blu-ray Disc™, DVD Players
- Set-Top Boxes
- Mini/Micro Combo Systems
- Sound Cards
- Laptops

### 3 Description

The TPA6138A2 is a pop-free stereo headphone amplifier designed to allow the removal of the output dc-blocking capacitors for reduced component count and cost. The device is ideal for single-supply electronics where size and cost are critical design parameters.

Designed using TI's patented DirectPath™ technology, The TPA6138A2 is capable of driving 25 mW into a 32-Ω load with 3.3-V supply voltage. The device has differential inputs and uses external gain-setting resistors that supports a gain range of  $\pm 1$  V/V to  $\pm 10$  V/V. Gain can be configured individually for each channel. The device can also be configured as a second-order low-pass filter and is ideal for interfacing with PWM audio sources. Audio output complies with  $\pm 8$ -kV IEC ESD protection, requiring just a simple resistor-capacitor ESD protection circuit. The TPA6138A2 has built-in active-mute control for pop-free audio on/off control. The TPA6138A2 has an external undervoltage detector that mutes the output when the power supply is removed, ensuring a pop-free shutdown.

Using the TPA6138A2 in audio products can reduce component count considerably compared to traditional headphone amplifiers. The TPA6138A2 does not require a split-rail power supply or a dc blocking capacitor. The TPA6138A2 integrates its own charge pump to generate a negative supply rail that provides a clean, pop-free ground-biased audio signal.

The TPA6138A2 is available in a 14-pin TSSOP.

#### Device Information<sup>(1)</sup>

PART NUMBER	PACKAGE	BODY SIZE (NOM)
TPA6138A2	TSSOP (14)	5.00 mm x 4.40 mm

(1) For all available packages, see the orderable addendum at the end of the datasheet.

#### Simplified Diagram

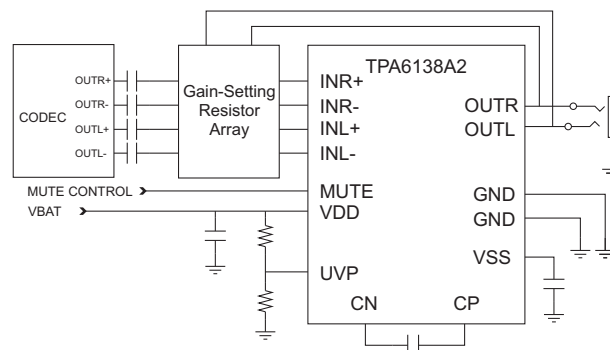

## Table of Contents

<b>1</b>	<b>Features</b> .....	<b>1</b>	9.2	Functional Block Diagram .....	<b>8</b>
<b>2</b>	<b>Applications</b> .....	<b>1</b>	9.3	Feature Description .....	<b>8</b>
<b>3</b>	<b>Description</b> .....	<b>1</b>	9.4	Device Functional Modes .....	<b>9</b>
<b>4</b>	<b>Revision History</b> .....	<b>2</b>	<b>10</b>	<b>Application and Implementation</b> .....	<b>11</b>
<b>5</b>	<b>Device Comparison Table</b> .....	<b>3</b>	10.1	Application Information .....	<b>11</b>
<b>6</b>	<b>Pin Configuration and Functions</b> .....	<b>3</b>	10.2	Typical Application .....	<b>12</b>
<b>7</b>	<b>Specifications</b> .....	<b>4</b>	<b>11</b>	<b>Power Supply Recommendations</b> .....	<b>13</b>
7.1	Absolute Maximum Ratings .....	<b>4</b>	<b>12</b>	<b>Layout</b> .....	<b>14</b>
7.2	ESD Ratings .....	<b>4</b>	12.1	Layout Guidelines .....	<b>14</b>
7.3	Recommended Operating Conditions .....	<b>4</b>	12.2	Layout Example .....	<b>14</b>
7.4	Thermal Information .....	<b>4</b>	<b>13</b>	<b>Device and Documentation Support</b> .....	<b>15</b>
7.5	Electrical Characteristics .....	<b>5</b>	13.1	Device Support .....	<b>15</b>
7.6	Operating Characteristics .....	<b>5</b>	13.2	Community Resources .....	<b>15</b>
7.7	Typical Characteristics .....	<b>6</b>	13.3	Trademarks .....	<b>15</b>
<b>8</b>	<b>Parameter Measurement Information</b> .....	<b>7</b>	13.4	Electrostatic Discharge Caution .....	<b>15</b>
<b>9</b>	<b>Detailed Description</b> .....	<b>7</b>	13.5	Glossary .....	<b>15</b>
9.1	Overview .....	<b>7</b>	<b>14</b>	<b>Mechanical, Packaging, and Orderable Information</b> .....	<b>15</b>

## 4 Revision History

NOTE: Page numbers for previous revisions may differ from page numbers in the current version.

<b>Changes from Revision A (May 2011) to Revision B</b>	<b>Page</b>
• Added <i>Pin Configuration and Functions</i> section, <i>ESD Ratings</i> table, <i>Feature Description</i> section, <i>Device Functional Modes</i> , <i>Application and Implementation</i> section, <i>Power Supply Recommendations</i> section, <i>Layout</i> section, <i>Device and Documentation Support</i> section, <i>Parameter Measurement Information</i> section, and <i>Mechanical, Packaging, and Orderable Information</i> section .....	<b>1</b>
• Added the information in Section 8.1 as "Direct Path Headphone Driver" to Feature Description section .....	<b>8</b>
• Removed section "Gain-Setting Resistors" .....	<b>9</b>

<b>Changes from Original (January 2011) to Revision A</b>	<b>Page</b>
• Added Rev A and May 2011 to Header, No other changes to page 1 .....	<b>1</b>
• Changed Pin Functions Description for UVP pin from "connect to PVDD with a 10-kΩ resistor if function is unused" to "internal pull-up, unconnected if UVP function is unused" .....	<b>3</b>

## 5 Device Comparison Table

	TPA6138A2	TPA6130A2	TPA6132A2	TPA6133A2	TPA6136A2	TPA6140A2	TPA6141A2
Ground-Centered Outputs	Yes	Yes	Yes	Yes	Yes	Yes	Yes
Class-G	–	–	–	–	–	Yes	Yes
Special Features	Adj. Gain	-	Gain Select	Fixed Gain	Gain Select	–	Gain Select
Volume Control	–	Yes	–	–	–	Yes	–
Headphone Channels	Stereo	Stereo	Stereo	Stereo	Stereo	Stereo	Stereo
Output Power (W)	0.25	0.138	0.025	0.138	0.025	0.025	0.025
PSRR (dB)	80	109	100	109	100	105	105

## 6 Pin Configuration and Functions

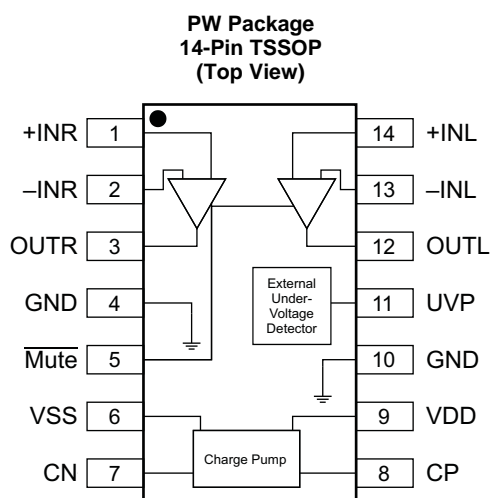

### Pin Functions

PIN		TYPE <sup>(1)</sup>	DESCRIPTION
NAME	NO.		
CN	7	I/O	Charge-pump flying capacitor negative connection
CP	8	I/O	Charge-pump flying capacitor positive connection
GND	4, 10	P	Ground
-INL	13	I	Left-channel OPAMP negative input
+INL	14	I	Left-channel OPAMP positive input
-INR	2	I	Right-channel OPAMP negative input
+INR	1	I	Right-channel OPAMP positive input
Mute	5	I	Mute, active-low
OUTL	12	O	Left-channel OPAMP output
OUTR	3	O	Right-channel OPAMP output
UVP	11	I	Undervoltage protection; internal pull-up, unconnected if UVP function is unused.
VDD	9	P	Positive supply
VSS	6	P	Supply voltage

(1) I = input, O = output, P = power

## 7 Specifications

### 7.1 Absolute Maximum Ratings

over operating free-air temperature range (unless otherwise noted)<sup>(1)</sup>

	MIN	MAX	UNIT
V <sub>DD</sub> to GND	-0.3	4	V
Input voltage, V <sub>I</sub>	V <sub>SS</sub> - 0.3	V <sub>DD</sub> + 0.3	V
Minimum load impedance – line outputs – OUTL, OUTR		12.8	Ω
Mute to GND, UVP to GND	-0.3	V <sub>DD</sub> + 0.3	V
Maximum operating junction temperature range, T <sub>J</sub>	-40	150	°C
Storage temperature range, T <sub>stg</sub>	-40	150	°C

- (1) Stresses beyond those listed under *Absolute Maximum Ratings* may cause permanent damage to the device. These are stress ratings only, and functional operation of the device at these or any other conditions beyond those indicated under *Recommended Operating Conditions* is not implied. Exposure to absolute-maximum-rated conditions for extended periods may affect device reliability.

### 7.2 ESD Ratings

		VALUE	UNIT
V <sub>(ESD)</sub>	Electrostatic discharge	Human body model (HBM), per ANSI/ESDA/JEDEC JS-001 <sup>(1)</sup>	±4000
		Charged-device model (CDM), per JEDEC specification JESD22-C101 <sup>(2)</sup>	±1500

- (1) JEDEC document JEP155 states that 500-V HBM allows safe manufacturing with a standard ESD control process.  
 (2) JEDEC document JEP157 states that 250-V CDM allows safe manufacturing with a standard ESD control process.

### 7.3 Recommended Operating Conditions

		MIN	NOM	MAX	UNIT		
V <sub>DD</sub>	Power supply	DC supply voltage		3	3.3	3.6	V
R <sub>L</sub>	Load impedance	16	32				Ω
V <sub>IL</sub>	Low-level input voltage	Mute		40			%V <sub>DD</sub>
V <sub>IH</sub>	High-level input voltage	Mute		60			%V <sub>DD</sub>
T <sub>A</sub>	Ambient temperature	-40	25	85			°C

### 7.4 Thermal Information

THERMAL METRIC <sup>(1)</sup>		TPA6138A2	UNIT
		PW (TSSOP)	
		14 PINS	
R <sub>θJA</sub>	Junction-to-ambient thermal resistance	130	°C/W
R <sub>θJC(top)</sub>	Junction-to-case (top) thermal resistance	49	°C/W
R <sub>θJB</sub>	Junction-to-board thermal resistance	63	°C/W
ψ <sub>JT</sub>	Junction-to-top characterization parameter	3.6	°C/W
ψ <sub>JB</sub>	Junction-to-board characterization parameter	62	°C/W

- (1) For more information about traditional and new thermal metrics, see the *Semiconductor and IC Package Thermal Metrics* application report, [SPRA953](#).

## 7.5 Electrical Characteristics

 $V_{DD} = 3.3\text{ V}$ ,  $R_{DL} = 32\ \Omega$ ,  $R_{fb} = 30\text{ k}\Omega$ ,  $R_{IN} = 15\text{ k}\Omega$ ,  $T_A = 25^\circ\text{C}$ , Charge pump:  $C_P = 1\ \mu\text{F}$  (unless otherwise noted)

PARAMETER		TEST CONDITIONS	MIN	TYP	MAX	UNIT
$ V_{OS} $	Output offset voltage	$V_{DD} = 3.3\text{ V}$		0.5	1	mV
PSRR	Power-supply rejection ratio			80		dB
$V_{OH}$	High-level output voltage	$V_{DD} = 3.3\text{ V}$	3.1			V
$V_{OL}$	Low-level output voltage	$V_{DD} = 3.3\text{ V}$			-3.05	V
$V_{UVP\_EX}$	External UVP detect voltage			1.25		V
$V_{UVP\_EX\_HYSTERESIS}$	External UVP detect hysteresis current			5		$\mu\text{A}$
$f_{CP}$	Charge-pump switching frequency		200	300	400	kHz
$ I_{IH} $	High-level input current, $\overline{\text{Mute}}$	$V_{DD} = 3.3\text{ V}$ , $V_{IH} = V_{DD}$			1	$\mu\text{A}$
$ I_{IL} $	Low-level input current, $\overline{\text{Mute}}$	$V_{DD} = 3.3\text{ V}$ , $V_{IL} = 0\text{ V}$			1	$\mu\text{A}$
$I_{DD}$	Supply current	$V_{DD} = 3.3\text{ V}$ , no load, $\overline{\text{Mute}} = V_{DD}$ , no load	5	14	25	mA
		$V_{DD} = 3.3\text{ V}$ , no load, $\overline{\text{Mute}} = \text{GND}$ , disabled		14		

## 7.6 Operating Characteristics

 $V_{DD} = 3.3\text{ V}$ ,  $R_{DL} = 32\ \Omega$ ,  $R_{fb} = 30\text{ k}\Omega$ ,  $R_{IN} = 15\text{ k}\Omega$ ,  $T_A = 25^\circ\text{C}$ , Charge pump:  $C_P = 1\ \mu\text{F}$  (unless otherwise noted)

PARAMETER		TEST CONDITIONS	MIN	TYP	MAX	UNIT
$P_O$	Output power, outputs in phase	THD+N = 1%, $V_{DD} = 3.3\text{ V}$ , $f = 1\text{ kHz}$ , $R_L = 32\ \Omega$		40		mW
THD+N	Total harmonic distortion plus noise	$V_{DD} = 3.3\text{ V}$ , $f = 1\text{ kHz}$ , $R_{LD} = 32\ \Omega$ , $P_o = 10\text{ mW}$		0.01%		
SNR	Signal-to-noise ratio <sup>(1)</sup>	A-weighted	90	96		dB
DNR	Dynamic range <sup>(2)</sup>	A-weighted	90	100		dB
$V_N$	Noise voltage	A-weighted		13		$\mu\text{V}$
$Z_O$	Output Impedance when muted	$\overline{\text{Mute}} = \text{GND}$		110		m $\Omega$
	Input-to-output attenuation when muted	$\overline{\text{Mute}} = \text{GND}$		80		dB
	Crosstalk—L to R, R to L	$P_o = 20\text{ mW}$		-75		dB
$I_{LIMIT}$	Current limit	$PVDD = 3.3\text{ V}$		50		mA

(1) SNR is calculated relative to 25-mW output.

(2) DNR is calculated relative to output at 1% THD+N.

### 7.7 Typical Characteristics

$V_{DD} = 3.3\text{ V}$ ,  $T_A = 25^\circ\text{C}$ ,  $C(\text{PUMP}) = C(\text{VSS}) = 1\ \mu\text{F}$ ,  $C_{IN} = 2.2\ \mu\text{F}$ ,  $R_{IN} = 15\ \text{k}\Omega$ ,  $R_{fb} = 30\ \text{k}\Omega$ ,  $R_{OUT} = 10\ \Omega$ ,  $C_{OUT} = 1\ \text{nF}$  (unless otherwise noted)

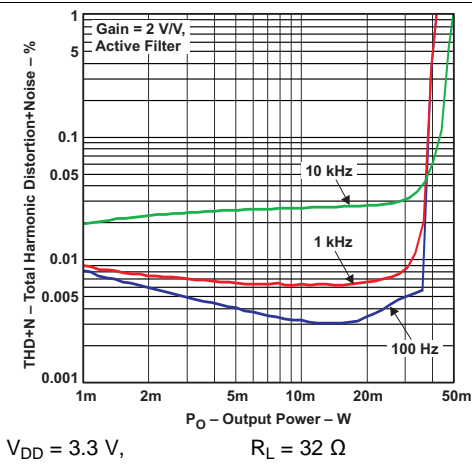

Figure 1. Total Harmonic Distortion and Noise vs Output Power

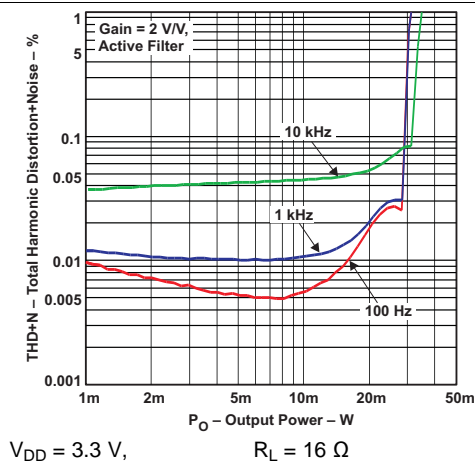

Figure 2. Total Harmonic Distortion and Noise vs Output Voltage

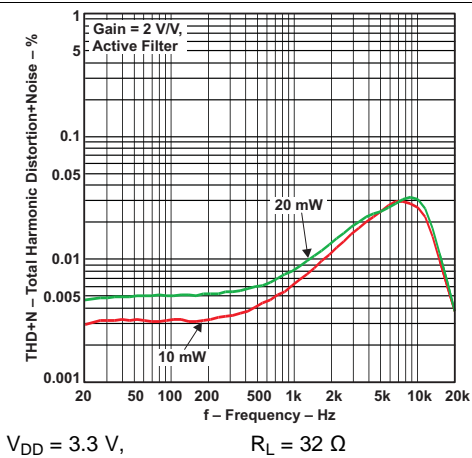

Figure 3. Total Harmonic Distortion and Noise vs Frequency

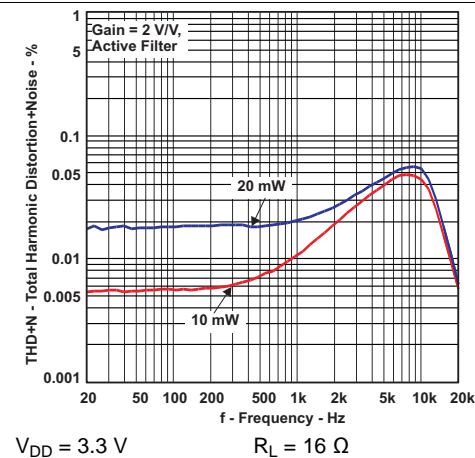

Figure 4. Total Harmonic Distortion and Noise vs Frequency

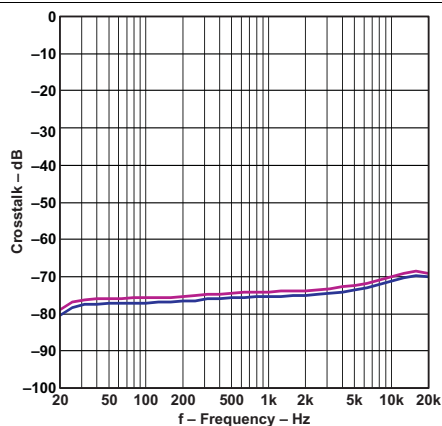

Figure 5. Crosstalk vs Frequency

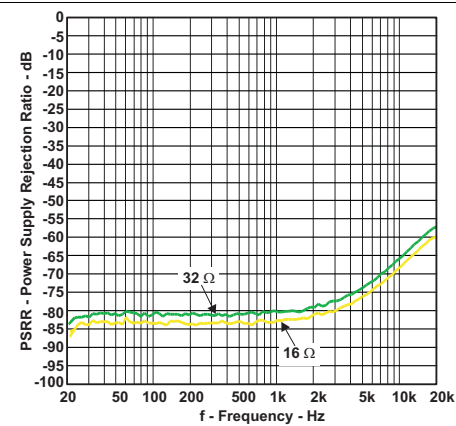

Figure 6. Supply Rejection Ratio vs Frequency

## 8 Parameter Measurement Information

All parameters are measured according to the conditions described in [Specifications](#).

## 9 Detailed Description

### 9.1 Overview

The TPA6138A2 is a DirectPath™ stereo headphone amplifier that requires no output DC blocking capacitors and is capable of delivering 25m-W into a 32-Ω load. The device has built-in pop suppression circuitry to completely eliminate pop noise during turn-on and turn-off. The amplifier outputs have short-circuit protection.

The TPA6138A2 features fully differential inputs to reduce system noise pickup between the audio source and the headphone amplifier. The high power supply noise rejection performance and differential architecture provides increased RF noise immunity.

The TPA6138A2 gain is controlled by external resistors  $R_{in}$  and  $R_{fb}$ , see the [Gain-Setting Resistor Ranges](#) section for recommended values.

The TPA6138A2 operates from a single 3-V to 3.6-V supply, as it uses a built-in charge pump to generate a negative voltage supply for the headphone amplifiers.

The TPA6138A2 features an external undervoltage protection which must be set according to [TPA6138A2 UVP Operation](#).

The TPA6138A2 can also be used as a standard operational amplifier (op amp), this makes possible to configure the device as a second-order low-pass filter to remove out-of-band noise.

## 9.2 Functional Block Diagram

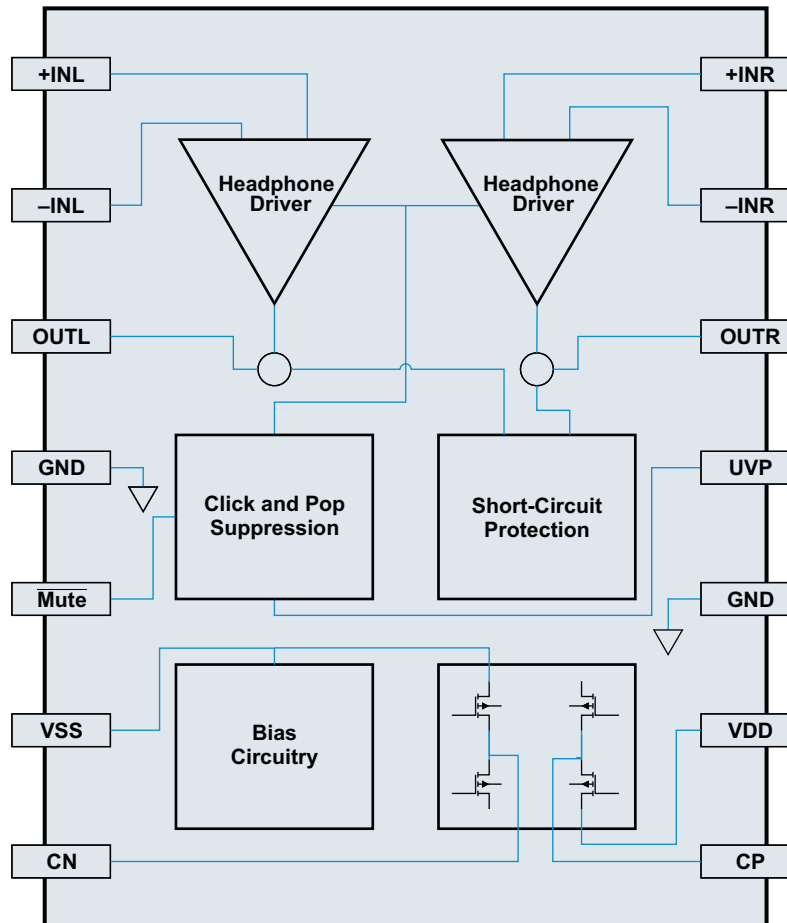

## 9.3 Feature Description

### 9.3.1 Direct Path Headphone Driver

Single-supply line-driver amplifiers typically require dc-blocking capacitors. The top drawing in [Figure 7](#) illustrates the conventional line-driver-amplifier connection to the load and output signal. DC blocking capacitors are often large in value. The headphone load (typical resistive values of 16 Ω to 32 Ω) combine with the dc blocking capacitors to form a high-pass filter. [Equation 1](#) shows the relationship between the load impedance ( $R_L$ ), the capacitor ( $C_O$ ), and the cutoff frequency ( $f_c$ ).

$$f_c = \frac{1}{2\pi R_L C_O} \quad (1)$$

$C_O$  can be determined using [Equation 2](#), where the load impedance and the cutoff frequency are known.

$$C_O = \frac{1}{2\pi R_L f_c} \quad (2)$$

If  $f_c$  is low, the capacitor must then have a large value because the load resistance is small. Large capacitance values require large package sizes. Large package sizes consume PCB area, stand high above the PCB, increase cost of assembly, and can reduce the fidelity of the audio output signal.



## Feature Description (continued)

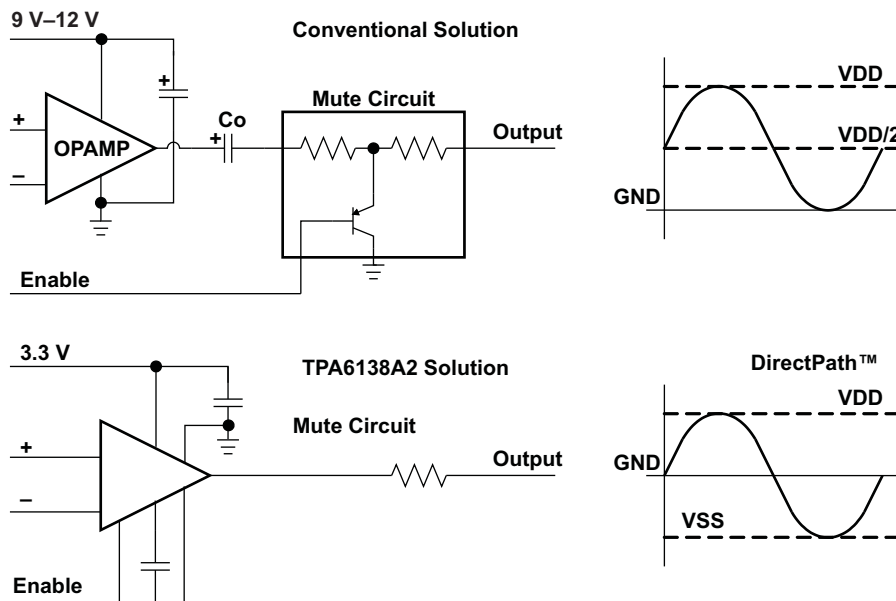

Figure 7. Conventional and DirectPath Line Driver

The DirectPath amplifier architecture operates from a single supply but makes use of an internal charge pump to provide a negative voltage rail. Combining the user-provided positive rail and the negative rail generated by the IC, the device operates in what is effectively a split-supply mode. The output voltages are now centered at zero volts with the capability to swing to the positive rail or negative rail. The DirectPath amplifier requires no output dc-blocking capacitors. The bottom block diagram and waveform of Figure 7 show the ground-referenced line-driver architecture. This is the architecture of the TPA6138A2.

## 9.4 Device Functional Modes

### 9.4.1 Mute Operation

The TPA6138A2 is able to turn off the output transistors by asserting to low level the Mute pin. This option is useful when an idle state is needed.

### 9.4.2 Using the TPA6138A2 as a Second-Order Filter

Several audio DACs used today require an external low-pass filter to remove out-of-band noise. This is possible with the TPA6138A2, as it can be used like a standard OPAMP. Several filter topologies can be implemented, both single-ended and differential. In Figure 8, a multi-feedback (MFB) topology with differential input and single-ended input is shown.

An ac-coupling capacitor to remove dc content from the source is shown; it serves to block any dc content from the source and lowers the dc gain to 1, helping to reduce the output dc offset to a minimum.

To calculate the component values, use the TI WEBENCH® Filter Designer ([www.ti.com/filterdesigner](http://www.ti.com/filterdesigner))

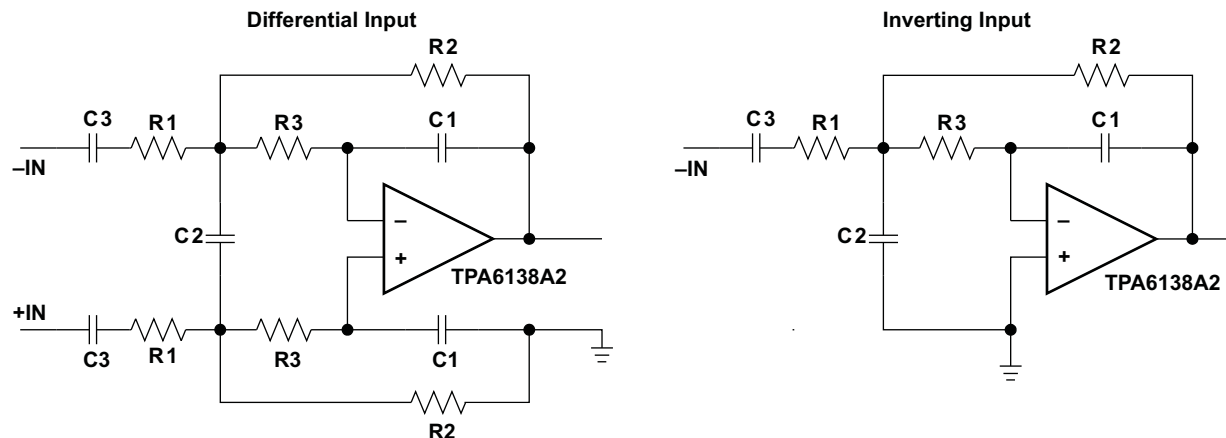
**Device Functional Modes (continued)**

**Figure 8. Second-Order Active Low-Pass Filter**

The resistor values should have a low value for obtaining low noise, but should also have a high enough value to allow use of a small-size ac-coupling capacitor. With the proposed values of 15 k $\Omega$ , 30 k $\Omega$ , and 43 k $\Omega$ , a dynamic range (DYR) of 106 dB can be achieved with a 1- $\mu$ F input ac-coupling capacitor.

**9.4.3 TPA6138A2 UVP Operation**

The shutdown threshold at the UVP pin is 1.25 V. The customer must use a resistor divider to obtain the shutdown threshold and hysteresis desired for a particular application. The customer-selected thresholds can be determined as follows:

$$V_{\text{UVP}} = (1.25 - 6 \mu\text{A} \times R_3) \times (R_1 + R_2) / R_2 \quad (3)$$

$$\text{Hysteresis} = 5 \mu\text{A} \times R_3 \times (R_1 + R_2) / R_2 \quad (4)$$

For example, to obtain  $V_{\text{UVP}} = 3.8$  V and 1-V hysteresis, we can use  $R_1 = 3$  k $\Omega$ ,  $R_2 = 1$  k $\Omega$  and  $R_3 = 50$  k $\Omega$ .

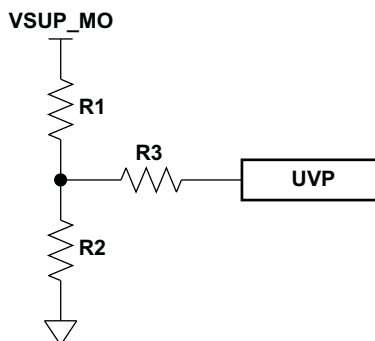
**Figure 9. UVP Resistor Divider**

## 10 Application and Implementation

### NOTE

Information in the following applications sections is not part of the TI component specification, and TI does not warrant its accuracy or completeness. TI's customers are responsible for determining suitability of components for their purposes. Customers should validate and test their design implementation to confirm system functionality.

### 10.1 Application Information

The TPA6138A2 starts its operation by asserting the MUTE pin to logic 1. The device enters in mute mode when pulling low MUTE pin. The charge pump generates a negative supply voltage. The charge pump flying capacitor connected between CP and CN transfers charge to generate the negative supply voltage. The output voltages are capable of positive and negative voltage swings and are centered close to 0 V, eliminating the need for output capacitors. Input coupling capacitors block any dc bias from the audio source and ensure maximum dynamic range. The device has built-in pop suppression circuitry to completely eliminate pop noise during turn-on, turn-off and enter or exit shutdown mode.

#### 10.1.1 Gain-Setting Resistor Ranges

The gain-setting resistors,  $R_{IN}$  and  $R_{fb}$ , must be chosen so that noise, stability, and input capacitor size of the TPA6138A2 are kept within acceptable limits. Voltage gain is defined as  $R_{fb}$  divided by  $R_{IN}$ .

Selecting values that are too low demands a large input ac-coupling capacitor,  $C_{IN}$ . Selecting values that are too high increases the noise of the amplifier. [Table 1](#) lists the recommended resistor values for different inverting-input gain settings.

**Table 1. Recommended Resistor Values**

GAIN	INPUT RESISTOR VALUE, $R_{IN}$	FEEDBACK RESISTOR VALUE, $R_{fb}$
-1 V/V	10 k $\Omega$	10 k $\Omega$
-1.5 V/V	8.2 k $\Omega$	12 k $\Omega$
-2 V/V	15 k $\Omega$	30 k $\Omega$
-10 V/V	4.7 k $\Omega$	47 k $\Omega$

#### 10.1.2 Input-Blocking Capacitors

DC input-blocking capacitors are required to be added in series with the audio signal into the input pins of the TPA6138A2. These capacitors block the dc portion of the audio source and allow the TPA6138A2 inputs to be properly biased to provide maximum performance.

These capacitors form a high-pass filter with the input resistor,  $R_{IN}$ . The cutoff frequency is calculated using [Equation 5](#). For this calculation, the capacitance used is the input-blocking capacitor and the resistance is the input resistor chosen from [Table 1](#); then the frequency and/or capacitance can be determined when one of the two values is given.

It is recommended to use electrolytic capacitors or high-voltage-rated capacitors as input blocking capacitors to ensure minimal variation in capacitance with input voltages. Such variation in capacitance with input voltages is commonly seen in ceramic capacitors and can increase low-frequency audio distortion.

$$f_{cIN} = \frac{1}{2\pi R_{IN} C_{IN}} \quad \text{or} \quad C_{IN} = \frac{1}{2\pi f_{cIN} R_{IN}} \quad (5)$$

## 10.2 Typical Application

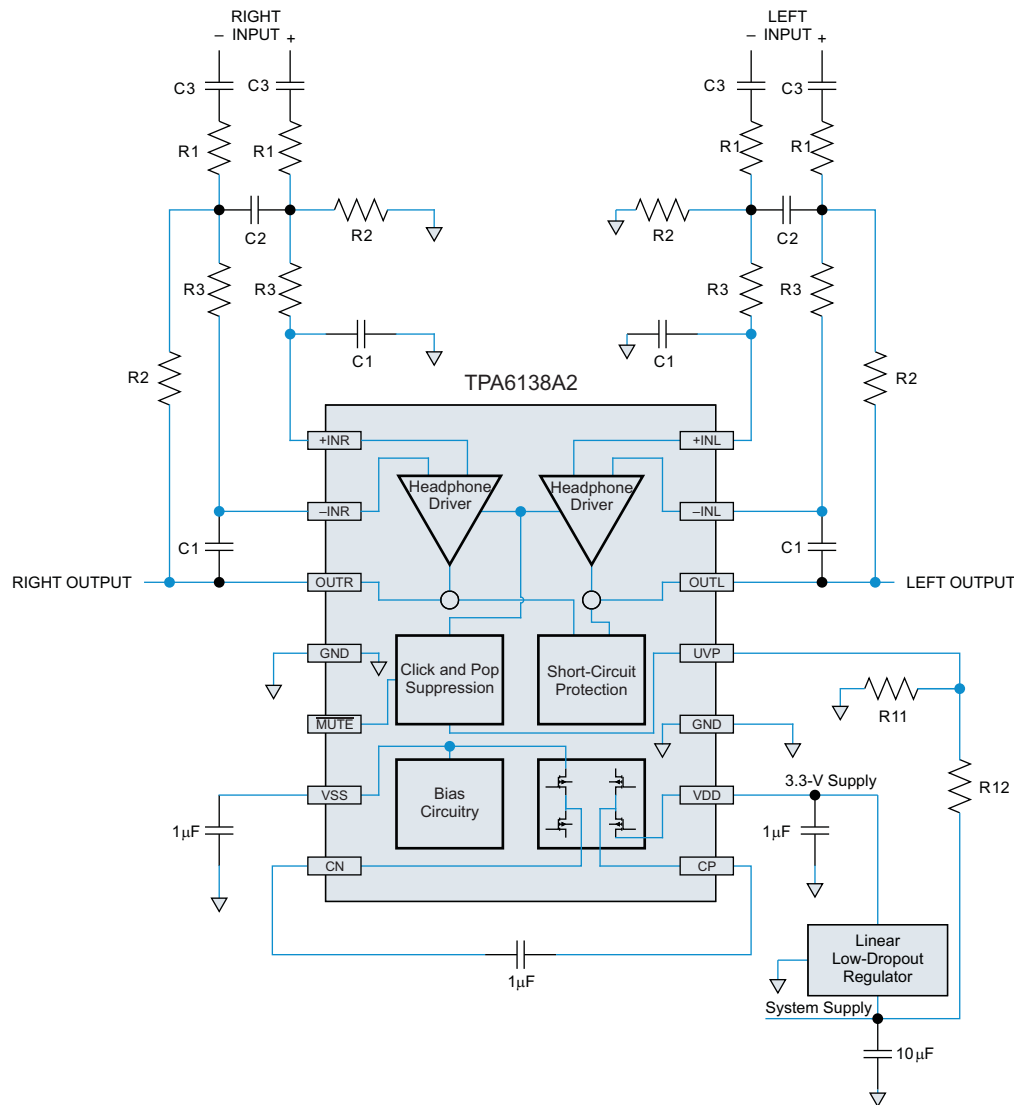

R1 = 15 kΩ, R2 = 30 kΩ, R3 = 43 kΩ, C1 = 47 pF, C2 = 180 pF

**Figure 10. Typical Application Schematic**

### 10.2.1 Design Requirements

This typical application requires the parameters listed in [Table 2](#).

**Table 2. Design Parameters**

PARAMETER	VALUES
Input voltage range	3 V to 3.6 V
Current	14 mA to 25 mA

## 10.2.2 Detailed Design Procedure

### 10.2.2.1 Charge-Pump Flying Capacitor and VSS Capacitor

The charge-pump flying capacitor serves to transfer charge during the generation of the negative supply voltage. The VSS capacitor must be at least equal to the charge-pump capacitor in order to allow maximum charge transfer. Low-ESR capacitors are an ideal selection, and a value of 1  $\mu\text{F}$  is typical. Capacitor values that are smaller than 1  $\mu\text{F}$  can be used, but the maximum output voltage may be reduced, and the device may not operate to specifications. If the TPA6138A2 is used in highly noise-sensitive circuits, it is recommended to add a small LC filter on the  $V_{\text{DD}}$  connection.

### 10.2.2.2 Decoupling Capacitors

The TPA6138A2 is a DirectPath headphone amplifier that requires adequate power-supply decoupling to ensure that the noise and total harmonic distortion (THD) are low. A good low equivalent-series-resistance (ESR) ceramic capacitor, typically 1  $\mu\text{F}$ , placed as close as possible to the device  $V_{\text{DD}}$  lead works best. Placing this decoupling capacitor close to the TPA6138A2 is important for the performance of the amplifier. For filtering lower-frequency noise signals, a 10- $\mu\text{F}$  or greater capacitor placed near the audio power amplifier would also help, but it is not required in most applications because of the high PSRR of this device.

## 10.2.3 Application Curves

See the curves listed in [Table 3](#) for the application curves.

**Table 3. Table of Graphs**

	<b>FIGURE</b>
Total Harmonic Distortion and Noise vs Output Power	<a href="#">Figure 1</a>
Total Harmonic Distortion and Noise vs Output Voltage	<a href="#">Figure 2</a>
Total Harmonic Distortion and Noise vs Frequency	<a href="#">Figure 3</a>
Total Harmonic Distortion and Noise vs Frequency	<a href="#">Figure 4</a>
Crosstalk vs Frequency	<a href="#">Figure 5</a>
Supply Rejection Ratio vs Frequency	<a href="#">Figure 6</a>

## 11 Power Supply Recommendations

The TPA6138A2 DirectPath headphone amplifier requires adequate power supply decoupling to ensure that output noise and total harmonic distortion (THD) remain low. Use good low equivalent-series-resistance (ESR) ceramic capacitors (X5R material or better is required for best performance). Place a 2.2  $\mu\text{F}$  capacitor within 5 mm of the VDD pin. Reducing the distance between the decoupling capacitor and VDD minimizes parasitic inductance and resistance, improving TPA6138A2 supply rejection performance. Use 0402 or smaller size capacitors if possible.

For additional supply rejection, connect an additional 10  $\mu\text{F}$  or higher value capacitor between VDD and ground. This will help filter lower frequency power supply noise. The high power supply rejection ratio (PSRR) of the TPA6138A2 makes the 10 $\mu\text{F}$  capacitor unnecessary in most applications.

## 12 Layout

### 12.1 Layout Guidelines

#### 12.1.1 Gain-Setting Resistors

The gain-setting resistors,  $R_{IN}$  and  $R_{fb}$ , must be placed close to pins 13 and 17, respectively, to minimize capacitive loading on these input pins and to ensure maximum stability of the TPA6138A2. For the recommended PCB layout, see the TPA6138A2EVM User's Guide ([SLOU305](#)).

#### 12.1.2 Decoupling Capacitors Placement

A low equivalent-series-resistance (ESR) ceramic capacitor, typically 1  $\mu$ F, placed as close as possible to the device VDD lead works best. Placing this decoupling capacitor close to the TPA6138A2 is important for the performance of the amplifier. For filtering lower-frequency noise signals, a 10- $\mu$ F or greater capacitor placed near the audio power amplifier would also help, but it is not required in most applications because of the high PSRR of this device

### 12.2 Layout Example

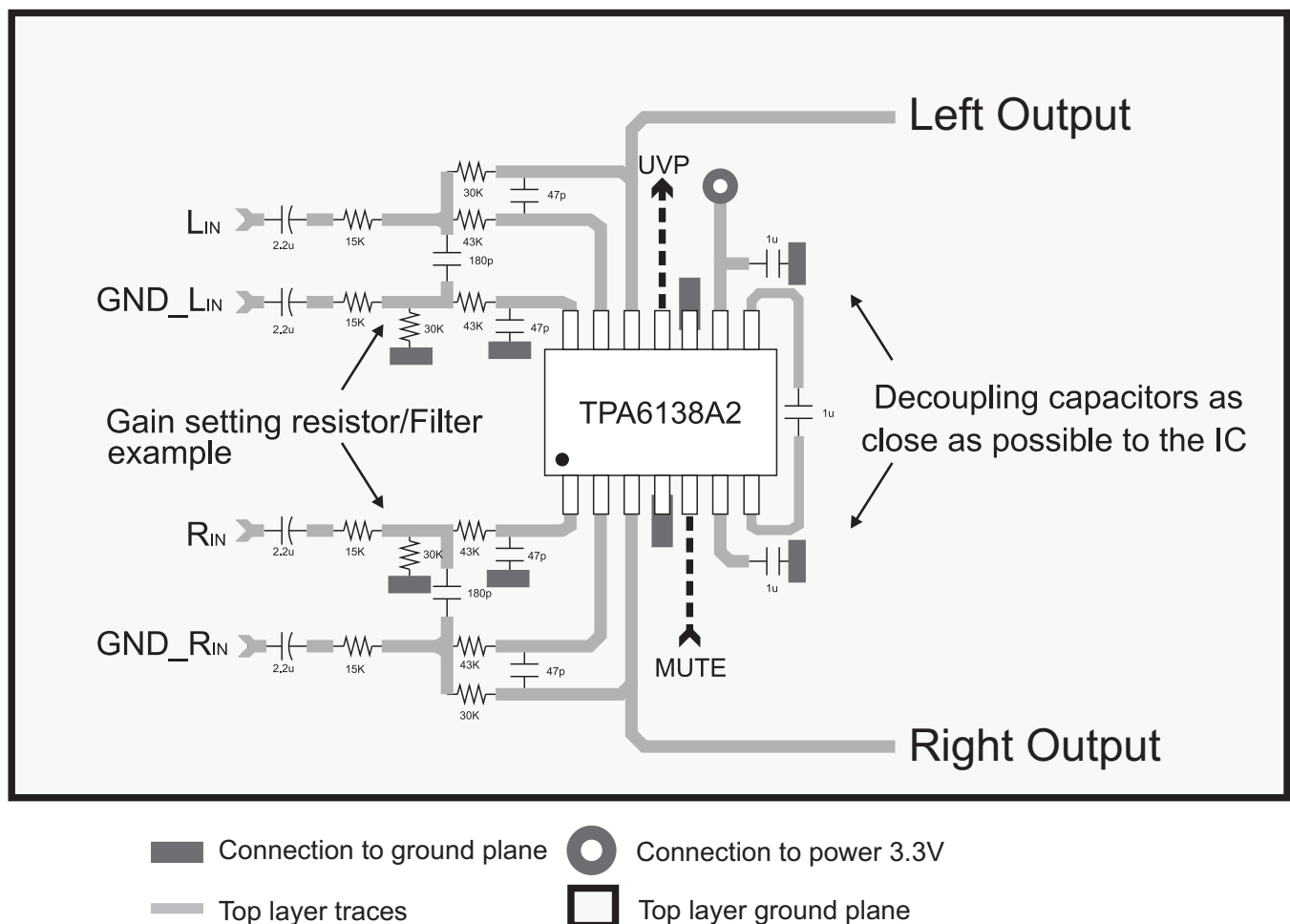

## 13 Device and Documentation Support

### 13.1 Device Support

#### 13.1.1 Development Support

For the TPA6138A2EVM and Gerber files, go to [www.ti.com/tool/TPA6138A2EVM](http://www.ti.com/tool/TPA6138A2EVM).

### 13.2 Community Resources

The following links connect to TI community resources. Linked contents are provided "AS IS" by the respective contributors. They do not constitute TI specifications and do not necessarily reflect TI's views; see TI's [Terms of Use](#).

**TI E2E™ Online Community** *TI's Engineer-to-Engineer (E2E) Community*. Created to foster collaboration among engineers. At [e2e.ti.com](http://e2e.ti.com), you can ask questions, share knowledge, explore ideas and help solve problems with fellow engineers.

**Design Support** *TI's Design Support* Quickly find helpful E2E forums along with design support tools and contact information for technical support.

### 13.3 Trademarks

DirectPath, E2E are trademarks of Texas Instruments.  
WEBENCH is a registered trademark of Texas Instruments.  
Blu-ray Disc is a trademark of Blu-ray Disc Association.  
All other trademarks are the property of their respective owners.

### 13.4 Electrostatic Discharge Caution



These devices have limited built-in ESD protection. The leads should be shorted together or the device placed in conductive foam during storage or handling to prevent electrostatic damage to the MOS gates.

### 13.5 Glossary

[SLYZ022](#) — *TI Glossary*.

This glossary lists and explains terms, acronyms, and definitions.

## 14 Mechanical, Packaging, and Orderable Information

The following pages include mechanical, packaging, and orderable information. This information is the most current data available for the designated devices. This data is subject to change without notice and revision of this document. For browser-based versions of this data sheet, refer to the left-hand navigation.

**PACKAGING INFORMATION**

Orderable Device	Status (1)	Package Type	Package Drawing	Pins	Package Qty	Eco Plan (2)	Lead/Ball Finish (6)	MSL Peak Temp (3)	Op Temp (°C)	Device Marking (4/5)	Samples
HPA01075PWR	ACTIVE	TSSOP	PW	14	2000	Green (RoHS & no Sb/Br)	CU NIPDAU	Level-2-260C-1 YEAR	-40 to 85	TPA6138	<a href="#">Samples</a>
TPA6138A2PW	ACTIVE	TSSOP	PW	14	90	Green (RoHS & no Sb/Br)	CU NIPDAU	Level-2-260C-1 YEAR	-40 to 85	TPA6138	<a href="#">Samples</a>
TPA6138A2PWR	ACTIVE	TSSOP	PW	14	2000	Green (RoHS & no Sb/Br)	CU NIPDAU	Level-2-260C-1 YEAR	-40 to 85	TPA6138	<a href="#">Samples</a>

(1) The marketing status values are defined as follows:

**ACTIVE:** Product device recommended for new designs.

**LIFEBUY:** TI has announced that the device will be discontinued, and a lifetime-buy period is in effect.

**NRND:** Not recommended for new designs. Device is in production to support existing customers, but TI does not recommend using this part in a new design.

**PREVIEW:** Device has been announced but is not in production. Samples may or may not be available.

**OBsolete:** TI has discontinued the production of the device.

(2) Eco Plan - The planned eco-friendly classification: Pb-Free (RoHS), Pb-Free (RoHS Exempt), or Green (RoHS & no Sb/Br) - please check <http://www.ti.com/productcontent> for the latest availability information and additional product content details.

**TBD:** The Pb-Free/Green conversion plan has not been defined.

**Pb-Free (RoHS):** TI's terms "Lead-Free" or "Pb-Free" mean semiconductor products that are compatible with the current RoHS requirements for all 6 substances, including the requirement that lead not exceed 0.1% by weight in homogeneous materials. Where designed to be soldered at high temperatures, TI Pb-Free products are suitable for use in specified lead-free processes.

**Pb-Free (RoHS Exempt):** This component has a RoHS exemption for either 1) lead-based flip-chip solder bumps used between the die and package, or 2) lead-based die adhesive used between the die and leadframe. The component is otherwise considered Pb-Free (RoHS compatible) as defined above.

**Green (RoHS & no Sb/Br):** TI defines "Green" to mean Pb-Free (RoHS compatible), and free of Bromine (Br) and Antimony (Sb) based flame retardants (Br or Sb do not exceed 0.1% by weight in homogeneous material)

(3) MSL, Peak Temp. - The Moisture Sensitivity Level rating according to the JEDEC industry standard classifications, and peak solder temperature.

(4) There may be additional marking, which relates to the logo, the lot trace code information, or the environmental category on the device.

(5) Multiple Device Markings will be inside parentheses. Only one Device Marking contained in parentheses and separated by a "~" will appear on a device. If a line is indented then it is a continuation of the previous line and the two combined represent the entire Device Marking for that device.

(6) Lead/Ball Finish - Orderable Devices may have multiple material finish options. Finish options are separated by a vertical ruled line. Lead/Ball Finish values may wrap to two lines if the finish value exceeds the maximum column width.

**Important Information and Disclaimer:** The information provided on this page represents TI's knowledge and belief as of the date that it is provided. TI bases its knowledge and belief on information provided by third parties, and makes no representation or warranty as to the accuracy of such information. Efforts are underway to better integrate information from third parties. TI has taken and



continues to take reasonable steps to provide representative and accurate information but may not have conducted destructive testing or chemical analysis on incoming materials and chemicals. TI and TI suppliers consider certain information to be proprietary, and thus CAS numbers and other limited information may not be available for release.

In no event shall TI's liability arising out of such information exceed the total purchase price of the TI part(s) at issue in this document sold by TI to Customer on an annual basis.

## TAPE AND REEL INFORMATION



### QUADRANT ASSIGNMENTS FOR PIN 1 ORIENTATION IN TAPE



\*All dimensions are nominal

Device	Package Type	Package Drawing	Pins	SPQ	Reel Diameter (mm)	Reel Width W1 (mm)	A0 (mm)	B0 (mm)	K0 (mm)	P1 (mm)	W (mm)	Pin1 Quadrant
TPA6138A2PWR	TSSOP	PW	14	2000	330.0	12.4	6.9	5.6	1.6	8.0	12.0	Q1

**TAPE AND REEL BOX DIMENSIONS**

\*All dimensions are nominal

Device	Package Type	Package Drawing	Pins	SPQ	Length (mm)	Width (mm)	Height (mm)
TPA6138A2PWR	TSSOP	PW	14	2000	367.0	367.0	38.0

PW (R-PDSO-G14)

PLASTIC SMALL OUTLINE



4040064-3/G 02/11

- NOTES:
- A. All linear dimensions are in millimeters. Dimensioning and tolerancing per ASME Y14.5M-1994.
  - B. This drawing is subject to change without notice.
  - C. Body length does not include mold flash, protrusions, or gate burrs. Mold flash, protrusions, or gate burrs shall not exceed 0,15 each side.
  - D. Body width does not include interlead flash. Interlead flash shall not exceed 0,25 each side.
  - E. Falls within JEDEC MO-153

PW (R-PDSO-G14)

PLASTIC SMALL OUTLINE



4211284-2/G 08/15

- NOTES:
- All linear dimensions are in millimeters.
  - This drawing is subject to change without notice.
  - Publication IPC-7351 is recommended for alternate designs.
  - Laser cutting apertures with trapezoidal walls and also rounding corners will offer better paste release. Customers should contact their board assembly site for stencil design recommendations. Refer to IPC-7525 for other stencil recommendations.
  - Customers should contact their board fabrication site for solder mask tolerances between and around signal pads.

## IMPORTANT NOTICE

Texas Instruments Incorporated (TI) reserves the right to make corrections, enhancements, improvements and other changes to its semiconductor products and services per JESD46, latest issue, and to discontinue any product or service per JESD48, latest issue. Buyers should obtain the latest relevant information before placing orders and should verify that such information is current and complete.

TI's published terms of sale for semiconductor products (<http://www.ti.com/sc/docs/stdterms.htm>) apply to the sale of packaged integrated circuit products that TI has qualified and released to market. Additional terms may apply to the use or sale of other types of TI products and services.

Reproduction of significant portions of TI information in TI data sheets is permissible only if reproduction is without alteration and is accompanied by all associated warranties, conditions, limitations, and notices. TI is not responsible or liable for such reproduced documentation. Information of third parties may be subject to additional restrictions. Resale of TI products or services with statements different from or beyond the parameters stated by TI for that product or service voids all express and any implied warranties for the associated TI product or service and is an unfair and deceptive business practice. TI is not responsible or liable for any such statements.

Buyers and others who are developing systems that incorporate TI products (collectively, "Designers") understand and agree that Designers remain responsible for using their independent analysis, evaluation and judgment in designing their applications and that Designers have full and exclusive responsibility to assure the safety of Designers' applications and compliance of their applications (and of all TI products used in or for Designers' applications) with all applicable regulations, laws and other applicable requirements. Designer represents that, with respect to their applications, Designer has all the necessary expertise to create and implement safeguards that (1) anticipate dangerous consequences of failures, (2) monitor failures and their consequences, and (3) lessen the likelihood of failures that might cause harm and take appropriate actions. Designer agrees that prior to using or distributing any applications that include TI products, Designer will thoroughly test such applications and the functionality of such TI products as used in such applications.

TI's provision of technical, application or other design advice, quality characterization, reliability data or other services or information, including, but not limited to, reference designs and materials relating to evaluation modules, (collectively, "TI Resources") are intended to assist designers who are developing applications that incorporate TI products; by downloading, accessing or using TI Resources in any way, Designer (individually or, if Designer is acting on behalf of a company, Designer's company) agrees to use any particular TI Resource solely for this purpose and subject to the terms of this Notice.

TI's provision of TI Resources does not expand or otherwise alter TI's applicable published warranties or warranty disclaimers for TI products, and no additional obligations or liabilities arise from TI providing such TI Resources. TI reserves the right to make corrections, enhancements, improvements and other changes to its TI Resources. TI has not conducted any testing other than that specifically described in the published documentation for a particular TI Resource.

Designer is authorized to use, copy and modify any individual TI Resource only in connection with the development of applications that include the TI product(s) identified in such TI Resource. NO OTHER LICENSE, EXPRESS OR IMPLIED, BY ESTOPPEL OR OTHERWISE TO ANY OTHER TI INTELLECTUAL PROPERTY RIGHT, AND NO LICENSE TO ANY TECHNOLOGY OR INTELLECTUAL PROPERTY RIGHT OF TI OR ANY THIRD PARTY IS GRANTED HEREIN, including but not limited to any patent right, copyright, mask work right, or other intellectual property right relating to any combination, machine, or process in which TI products or services are used. Information regarding or referencing third-party products or services does not constitute a license to use such products or services, or a warranty or endorsement thereof. Use of TI Resources may require a license from a third party under the patents or other intellectual property of the third party, or a license from TI under the patents or other intellectual property of TI.

TI RESOURCES ARE PROVIDED "AS IS" AND WITH ALL FAULTS. TI DISCLAIMS ALL OTHER WARRANTIES OR REPRESENTATIONS, EXPRESS OR IMPLIED, REGARDING RESOURCES OR USE THEREOF, INCLUDING BUT NOT LIMITED TO ACCURACY OR COMPLETENESS, TITLE, ANY EPIDEMIC FAILURE WARRANTY AND ANY IMPLIED WARRANTIES OF MERCHANTABILITY, FITNESS FOR A PARTICULAR PURPOSE, AND NON-INFRINGEMENT OF ANY THIRD PARTY INTELLECTUAL PROPERTY RIGHTS. TI SHALL NOT BE LIABLE FOR AND SHALL NOT DEFEND OR INDEMNIFY DESIGNER AGAINST ANY CLAIM, INCLUDING BUT NOT LIMITED TO ANY INFRINGEMENT CLAIM THAT RELATES TO OR IS BASED ON ANY COMBINATION OF PRODUCTS EVEN IF DESCRIBED IN TI RESOURCES OR OTHERWISE. IN NO EVENT SHALL TI BE LIABLE FOR ANY ACTUAL, DIRECT, SPECIAL, COLLATERAL, INDIRECT, PUNITIVE, INCIDENTAL, CONSEQUENTIAL OR EXEMPLARY DAMAGES IN CONNECTION WITH OR ARISING OUT OF TI RESOURCES OR USE THEREOF, AND REGARDLESS OF WHETHER TI HAS BEEN ADVISED OF THE POSSIBILITY OF SUCH DAMAGES.

Unless TI has explicitly designated an individual product as meeting the requirements of a particular industry standard (e.g., ISO/TS 16949 and ISO 26262), TI is not responsible for any failure to meet such industry standard requirements.

Where TI specifically promotes products as facilitating functional safety or as compliant with industry functional safety standards, such products are intended to help enable customers to design and create their own applications that meet applicable functional safety standards and requirements. Using products in an application does not by itself establish any safety features in the application. Designers must ensure compliance with safety-related requirements and standards applicable to their applications. Designer may not use any TI products in life-critical medical equipment unless authorized officers of the parties have executed a special contract specifically governing such use. Life-critical medical equipment is medical equipment where failure of such equipment would cause serious bodily injury or death (e.g., life support, pacemakers, defibrillators, heart pumps, neurostimulators, and implantables). Such equipment includes, without limitation, all medical devices identified by the U.S. Food and Drug Administration as Class III devices and equivalent classifications outside the U.S.

TI may expressly designate certain products as completing a particular qualification (e.g., Q100, Military Grade, or Enhanced Product). Designers agree that it has the necessary expertise to select the product with the appropriate qualification designation for their applications and that proper product selection is at Designers' own risk. Designers are solely responsible for compliance with all legal and regulatory requirements in connection with such selection.

Designer will fully indemnify TI and its representatives against any damages, costs, losses, and/or liabilities arising out of Designer's non-compliance with the terms and provisions of this Notice.