

TPA3140D2 10-W Inductor Free Stereo (BTL) Class-D Audio Amplifier with Ultra Low EMI and AGL

1 Features

- 2x10 W/ch into 6-Ω Loads at 10% THD+N from a 12-V Supply
- 2x10 W/ch into 8-Ω Loads at 10% THD+N from a 13-V Supply
- Up to 90% Efficient Class-D Operation (8 Ω) Eliminates Need for Heat Sinks
- <0.05% THD+N at 1 W/4 Ω/1 kHz
- <65-μV A-wgt Output Noise
- Wide Supply Voltage Range Allows Operation from 4.5 V to 14.4 V
- Inductor-Free Operation
- Enhanced EMI Performance with Spread Spectrum and 1SPW Operation
- SpeakerGuard™ Speaker Protection Includes Automatic Gain Limit, Adjustable Power Limiter and DC Protection
- Robust Pin-to-Pin, Pin-to-Ground and Pin-to-Power Short Circuit Protection and Thermal Protection
- Four Selectable, Fixed Gain Settings
- Single Ended or Differential Analog Inputs
- Click and Pop Free Startup

2 Applications

- Televisions
- BT Speakers
- Wireless Speakers
- Mini Speakers
- USB Speakers
- Consumer Audio Equipment

4 Simplified Schematic

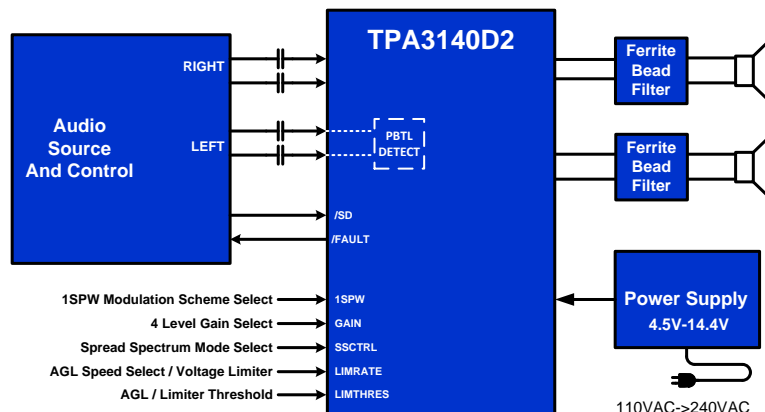

3 Description

The TPA3140D2 is an efficient, Class-D audio power amplifier for driving bridged-tied stereo speakers at up to 10 W/6 Ω or 8 Ω (per channel).

Advanced EMI Suppression Technology with Spread Spectrum Control and 1SPW modulation scheme enables the use of inexpensive ferrite bead filters at the outputs while meeting EMC requirements for system cost reduction. TPA3140D2 is not only fully protected against shorts and overload, the SpeakerGuard™ speaker protection circuitry includes an adjustable Automatic Gain Limit (AGL), an adjustable power limiter and a DC detection circuit for protection of the connected speakers. The AGL allows adjustment of the maximum output voltage without signal clipping for enhanced speaker protection and audio quality. The DC detect and Pin-to-Pin, Pin-to-Ground and Pin-to-Power Short Circuit protection circuit protect the speakers from output DC and pin shorts caused in production. The outputs are also fully protected against shorts to GND, PVCC, and output-to-output. The short-circuit protection and thermal protection includes an auto recovery feature.

The TPA3140D2 can drive stereo speakers with as low as 4-Ω impedance. The high efficiency of the TPA3140D2, 90% with 8-Ω load, eliminates the need for an external heat sink, and TPA3140D2 will be able to output full power on a 2-layer PCB.

Device Information⁽¹⁾

PART NUMBER	PACKAGE	BODY SIZE (NOM)
TPA3140D2	HTSSOP (28)	9.70 mm x 4.40 mm

(1) For all available packages, see the orderable addendum at the end of the datasheet.



Table of Contents

1 Features	1	10.3 Feature Description.....	12
2 Applications	1	10.4 Device Functional Modes.....	19
3 Description	1	11 Application and Implementation	21
4 Simplified Schematic	1	11.1 Application Information.....	21
5 Revision History	2	11.2 Typical Applications	21
6 Device Comparison Table	3	12 Power Supply Recommendations	28
7 Pin Configuration and Functions	3	12.1 Power Supply Decoupling, C _S	28
8 Specifications	5	13 Layout	29
8.1 Absolute Maximum Ratings	5	13.1 Layout Guidelines	29
8.2 ESD Ratings	5	13.2 Layout Example	30
8.3 Recommended Operating Conditions.....	6	14 Device and Documentation Support	31
8.4 Thermal Information	6	14.1 Device Support.....	31
8.5 Electrical Characteristics.....	6	14.2 Documentation Support	31
8.6 Switching Characteristics	7	14.3 Community Resources.....	31
8.7 Typical Characteristics	8	14.4 Trademarks	31
9 Parameter Measurement Information	10	14.5 Electrostatic Discharge Caution.....	31
10 Detailed Description	11	14.6 Glossary	31
10.1 Overview	11	15 Mechanical, Packaging, and Orderable	
10.2 Functional Block Diagram	12	Information	32

5 Revision History

Changes from Original (January 2015) to Revision A

Page

• Changed from Product Preview to Production Data	1
---	----------

6 Device Comparison Table

DEVICE NAME	DESCRIPTION
TPA3113D2	6-W Stereo Class-D Audio Power Amplifier with SpeakerGuard™
TPA3131D2	7W Filter-Free Class-D Stereo Amplifier In Space Saving QFN
TPA3130D2	15W Filter-Free Class D Stereo Amplifier with AM Avoidance
TPA3110D2	15W Filter-Free Class D Stereo Amplifier with SpeakerGuard™

7 Pin Configuration and Functions

**PWP Package
28-Pin HTSSOP
(Top View)**

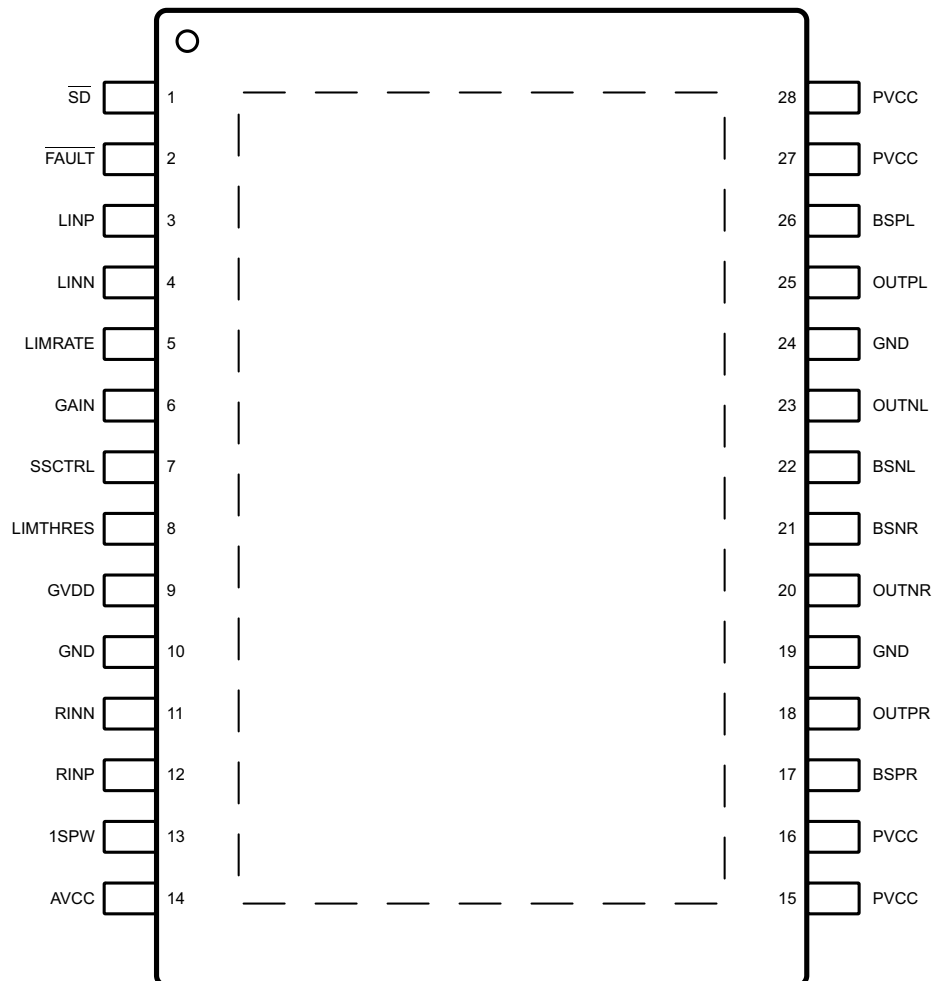

Pin Functions

PIN		I/O/P ⁽¹⁾	DESCRIPTION
NAME	NUMBER		
\overline{SD}	1	I	Shutdown logic input for audio amp (LOW = outputs Hi-Z, HIGH = outputs enabled). TTL logic levels with compliance to AVCC.
\overline{FAULT}	2	O	Open drain output used to display short circuit or dc detect fault status. Voltage compliant to AVCC. Short circuit faults can be set to auto-recovery by connecting \overline{FAULT} pin to \overline{SD} pin. Otherwise, both short circuit faults and dc detect faults must be reset by cycling PVCC.
LINP	3	I	Positive audio input for left channel. Biased at 3V. Connect to GND for PBTL mode.
LINN	4	I	Negative audio input for left channel. Biased at 3V. Connect to GND for PBTL mode.
LIMRATE	5	I	Decay speed for clip free power limiter. Connect a resistor divider from GVDD to GND to set decay speed. Connect directly to GND to disconnect limiter.
GAIN	6	I	4-state Amplifier gain select. Connect a resistor divider from GVDD to GND to set closed loop gain.
SSCTRL	7	I	Spread spectrum control. Connect a resistor divider from GVDD to GND to set mode. Connect to GND for disable spread spectrum.
LIMTHRES	8	I	Voltage limit level for AGL and power limiter. Connect a resistor divider from GVDD to GND to set limit. Connect directly to GVDD to disconnect limiter
GVDD	9	O	High-side FET gate drive supply. Nominal voltage is 7V. Also should be used as supply for LIMTHRES limit function
GND	10	P	Analog signal ground.
RINN	11	I	Negative audio input for right channel. Biased at 3V.
RINP	12	I	Positive audio input for right channel. Biased at 3V.
1SPW	13	I	Modulation scheme select. Low: BD mode, high: 1SPW mode.
AVCC	14	P	Analog supply
PVCC	15	P	Power supply for right channel H-bridge. Right channel and left channel power supply inputs are connected internally.
PVCC	16	P	Power supply for right channel H-bridge. Right channel and left channel power supply inputs are connected internally.
BSPR	17	I	Bootstrap I/O for right channel, positive high-side FET.
OUTPR	18	O	Class-D H-bridge positive output for right channel.
GND	19	P	Power ground for the H-bridges.
OUTNR	20	O	Class-D H-bridge negative output for right channel.
BSNR	21	I	Bootstrap I/O for right channel, negative high-side FET.
BSNL	22	I	Bootstrap I/O for left channel, negative high-side FET.
OUTNL	23	O	Class-D H-bridge negative output for left channel.
GND	24	P	Power ground for the H-bridges.
OUTPL	25	O	Class-D H-bridge positive output for left channel.
BSPL	26	I	Bootstrap I/O for left channel, positive high-side FET.
PVCC	27	P	Power supply for left channel H-bridge. Right channel and left channel power supply inputs are connected internally.
PVCC	28	P	Power supply for left channel H-bridge. Right channel and left channel power supply inputs are connected internally.
Thermal Pad		P	Connect to GND for best thermal and electrical performance

(1) I = Input, O = Output, P = Power

8 Specifications

8.1 Absolute Maximum Ratings

over operating free-air temperature range (unless otherwise noted) ⁽¹⁾

		MIN	MAX	UNIT
Supply voltage	AVCC to GND, PVCC to GND	-0.3	16	V
	GVDD to GND			V
	GND to GND	-0.3	0.3	V
Input current	To any pin except supply pins		10	mA
Voltage	\overline{SD} , FAULT, 1SPW to GND ⁽²⁾	-0.3	AVCC + 0.3	V
			10	V/ms
Voltage	GAIN, LIMRATE, LIMTHRES, SSCTRL ⁽³⁾	-0.3	GVDD + 0.3	V
			100	V/ms
Voltage	RINN, RINP, LINN, LINP	-0.3	6.3	V
Continuous total power dissipation		See the Thermal Information Table		
Operating free-air temperature range, T _A ⁽⁴⁾		-40	85	°C
Temperature range		-65	150	°C
Minimum load resistance, R _L	BTL, PVCC > 12 V	4.8		Ω
	BTL, PVCC ≤ 12 V	3.2		
	PBTL, PVCC > 12 V	2.5		
	PBTL, PVCC ≤ 12 V	1.8		
Storage temperature range, T _{stg}		-65	150	°C

- (1) Stresses beyond those listed under *Absolute Maximum Ratings* may cause permanent damage to the device. These are stress ratings only, which do not imply functional operation of the device at these or any other conditions beyond those indicated under *Recommended Operating Conditions*. Exposure to absolute-maximum-rated conditions for extended periods may affect device reliability.
- (2) The voltage slew rate of these pins must be restricted to no more than 10 V/ms. For higher slew rates, use a 100 kΩ resistor in series with the pins.
- (3) The voltage slew rate of these pins must be restricted to no more than 100 V/ms. For higher slew rates, use a 100 kΩ resistor in series with the pins.
- (4) The TPA3140D2 incorporates an exposed thermal pad on the underside of the chip. This acts as a heatsink, and it must be connected to a thermally dissipating plane for proper power dissipation. Failure to do so may result in the device going into thermal protection shutdown. See TI Technical Briefs [SLMA002](#) for more information about using the TSSOP thermal pad.

8.2 ESD Ratings

			VALUE	UNIT
V _(ESD)	Electrostatic discharge	Human body model (HBM), per ANSI/ESDA/JEDEC JS-001 ⁽¹⁾	±1000	V
		Charged device model (CDM), per JEDEC specification JESD22-C101 ⁽²⁾	±250	

- (1) JEDEC document JEP155 states that 500-V HBM allows safe manufacturing with a standard ESD control process.
- (2) JEDEC document JEP157 states that 250-V CDM allows safe manufacturing with a standard ESD control process.

8.3 Recommended Operating Conditions

over operating free-air temperature range (unless otherwise noted)

PARAMETER		TEST CONDITIONS	MIN	MAX	UNIT
V _{CC}	Supply voltage	PV _{CC} , AV _{CC}	4.5	14.4	V
V _{IH}	High-level input voltage	\overline{SD} , 1SPW	2	AV _{CC}	V
V _{IL}	Low-level input voltage	\overline{SD} , 1SPW		0.8	V
V _{OL}	Low-level output voltage	\overline{FAULT} , R _{PULL-UP} =100k, PV _{CC} =14.4V		0.8	V
I _{IH}	High-level input current	\overline{SD} , 1SPW, V _I = 2V, AV _{CC} = 12 V		50	μA
I _{IL}	Low-level input current	\overline{SD} , 1SPW, V _I = 0.8 V, AV _{CC} = 12 V		5	μA
T _A	Operating free-air temperature ⁽¹⁾		-40	85	°C
T _J	Operating junction temperature ⁽¹⁾		-40	150	°C

- (1) The TPA3140D2 incorporates an exposed thermal pad on the underside of the chip. This acts as a heatsink, and it must be connected to a thermally dissipating plane for proper power dissipation. Failure to do so may result in the device going into thermal protection shutdown. See TI Technical Briefs [SLMA002](#) for more information about using the TSSOP thermal pad.

8.4 Thermal Information

THERMAL METRIC ⁽¹⁾		PWP (HTSSOP)	UNIT
		28 PINS	
R _{θJA}	Junction-to-ambient thermal resistance	37.5	°C/W
R _{θJC(top)}	Junction-to-case (top) thermal resistance	19.4	
R _{θJB}	Junction-to-board thermal resistance	16.6	
Ψ _{JT}	Junction-to-top characterization parameter	0.6	
Ψ _{JB}	Junction-to-board characterization parameter	16.4	
R _{θJC(bot)}	Junction-to-case (bottom) thermal resistance	2.8	

- (1) For more information about traditional and new thermal metrics, see the *IC Package Thermal Metrics* application report, [SPRA953](#).

8.5 Electrical Characteristics

over operating free-air temperature range (unless otherwise noted)

PARAMETER		TEST CONDITIONS	MIN	TYP	MAX	UNIT	
DC CHARACTERISTICS, T_A = 25°C, AV_{CC} = PV_{CC} = 12 V, R_L = 6 Ω, using the TPA3140D2 EVM which is available at ti.com. (unless otherwise noted)							
V _{OS}	Class-D output offset voltage (measured differentially)	V _I = 0 V, Gain = 36 dB		1.5	15	mV	
I _{CC}	Quiescent supply current	\overline{SD} = 2 V, no load, 10μF+680nF Output Filter		35	40	mA	
I _{CC(SD)}	Quiescent supply current in shutdown mode	\overline{SD} = 0.8 V, no load		40	60	μA	
r _{DS(on)}	Drain-source on-state resistance	I _O = 500 mA, T _J = 25°C Excluding Metal and Bond Wire Resistance		240		mΩ	
		High Side		240			
G	Gain	GAIN = 0 V (GND)		19	20	21	dB
		GAIN = 2.3 V (1/3-GVDD)		25	26	27	
		GAIN = 4.6 V (2/3-GVDD)		31	32	33	
		GAIN = 6.9 V (GVDD)		35	36	37	
t _{on}	Turn-on time	\overline{SD} = 2 V		14		ms	
t _{OFF}	Turn-off time	\overline{SD} = 0.8 V		2.5		μs	
GVDD	Gate drive supply	I _{GVDD} = 2mA	6.4	6.9	7.4	V	
t _{DCDET}	DC detect time	V _{RINN} = 3.1V and V _{RINN} = 2.9V, or V _{RINN} = 2.9V and V _{RINN} = 3.1V		950		ms	

Electrical Characteristics (continued)

over operating free-air temperature range (unless otherwise noted)

PARAMETER		TEST CONDITIONS	MIN	TYP	MAX	UNIT
AC CHARACTERISTICS, $T_A = 25^\circ\text{C}$, $AV_{CC} = PV_{CC} = 12\text{ V}$, $R_L = 6\ \Omega$, using the TPA3140D2 EVM which is available at ti.com. (unless otherwise noted)						
PSRR	Power supply ripple rejection	200 mV _{PP} ripple at 1 kHz, Gain = 20 dB, Inputs ac-coupled to GND		-65		dB
P _O	Continuous output power	THD+N = 10%, f = 1 kHz		10		W
P _O	Continuous output power	THD+N = 10%, f = 1 kHz, PV _{CC} = 13V, R _L = 8 Ω		10		W
P _O	Continuous output power, PBTL (mono)	THD+N = 10%, f = 1 kHz, PV _{CC} = 13V, R _L = 4 Ω		20		W
I _O	Maximum output current	f = 1kHz, R _L =3 Ω		3.1		A
THD+N	Total harmonic distortion + noise	f = 1 kHz, P _O = 5 W (half-power)		0.06		%
V _n	Output integrated noise	20 Hz to 22 kHz, A-weighted filter, Gain = 20 dB, Spread Spectrum off		65		μV
				-80		dBV
	Crosstalk	V _O = 1 Vrms, Gain = 20 dB, f = 1 kHz		-75		dB
SNR	Signal-to-noise ratio	Maximum output at THD+N < 1%, f = 1 kHz, Gain = 20 dB, A-weighted, Spread Spectrum off		102		dB
OTE	Thermal trip point			150		$^\circ\text{C}$
	Thermal hysteresis			15		$^\circ\text{C}$
TFB	Thermal foldback trip point			125		$^\circ\text{C}$

8.6 Switching Characteristics

over operating free-air temperature range (unless otherwise noted)

PARAMETER		MIN	NOM	MAX	UNIT
f _{osc}	Oscillator frequency	250	310	350	kHz
f _{osc, ss}	Oscillator frequency, Spread Spectrum ON	255	315	355	kHz

8.7 Typical Characteristics

All Measurements taken at 20dB closed loop gain, 1-kHz audio, $T_A = 25^\circ\text{C}$ unless otherwise noted. Measurements were made with AES17 filter using the TPA3140D2 EVM, which is available at ti.com.

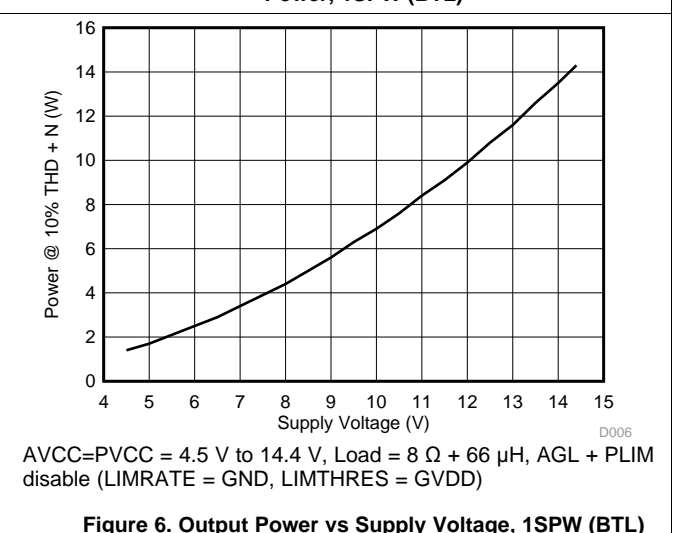
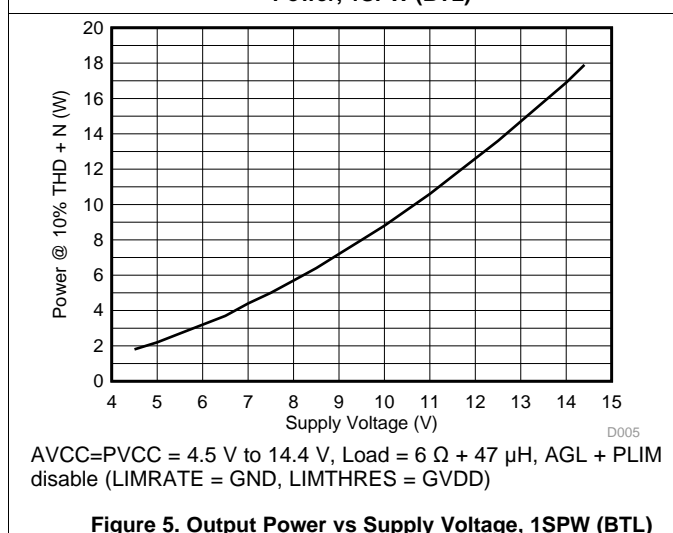
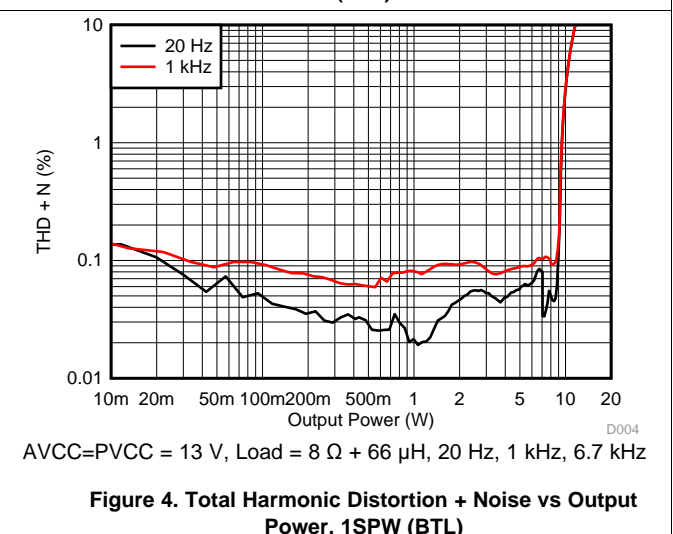
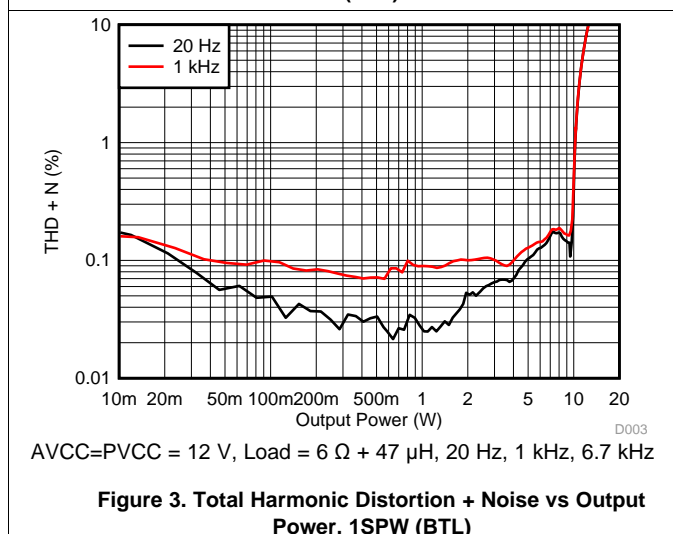
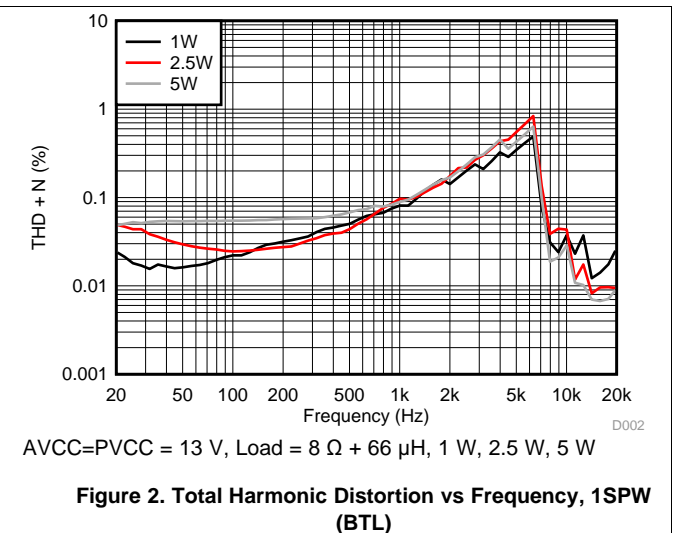
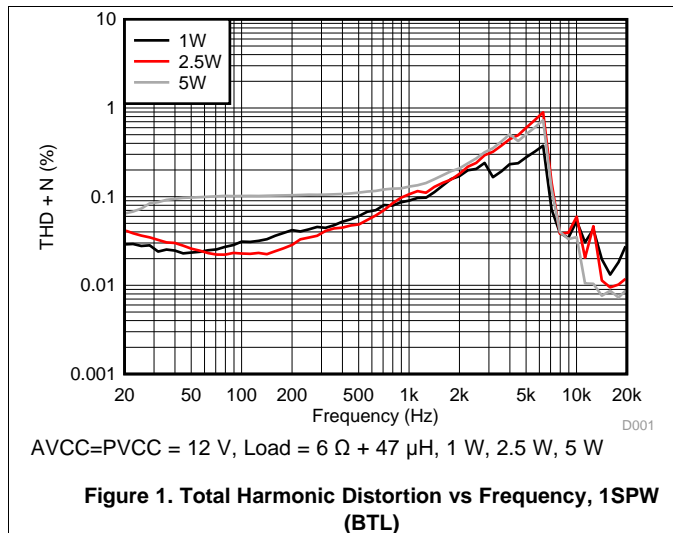

Typical Characteristics (continued)

All Measurements taken at 20dB closed loop gain, 1-kHz audio, $T_A = 25^\circ\text{C}$ unless otherwise noted. Measurements were made with AES17 filter using the TPA3140D2 EVM, which is available at ti.com.

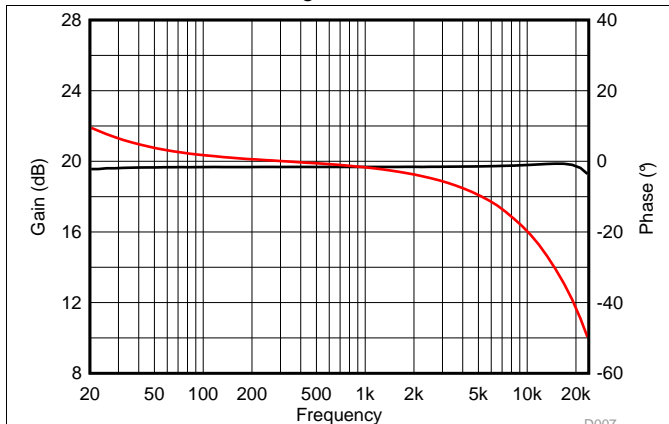

AVCC=PVCC = 12 V, Load = 6 Ω + 47 μH (device pins)

Figure 7. Gain/Phase vs Frequency (BTL)

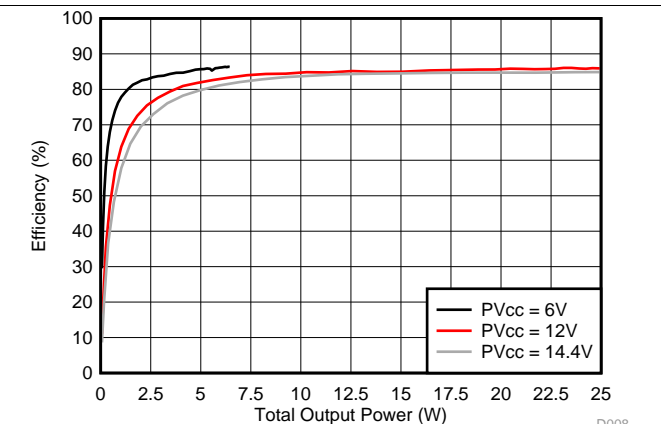

AVCC=PVCC = 6 V, 12 V, 14.4 V, Load = 6 Ω + 47 μH, AGL + PLIM disable (LIMRATE = GND, LIMTHRES = GVDD)

Figure 8. Efficiency vs Output Power, 1SPW (BTL)

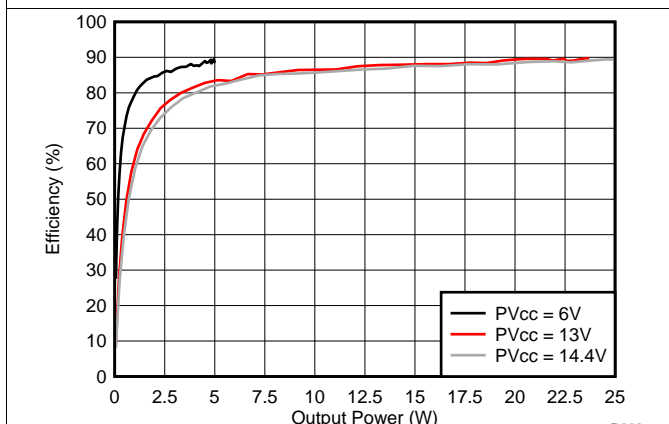

AVCC=PVCC= 6 V, 13 V, 14.4 V, Load = 8 Ω + 66 μH, AGL + PLIM disable (LIMRATE = GND, LIMTHRES = GVDD)

Figure 9. Efficiency vs Output Power, 1SPW (BTL)

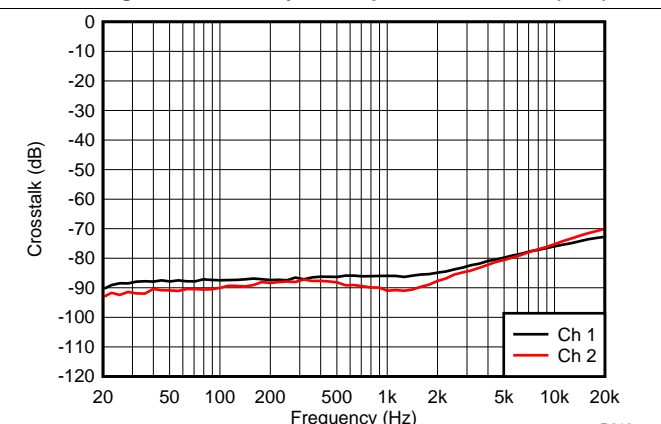

AVCC=PVCC = 12 V, 1 W, Load = 6 Ω + 47 μH

Figure 10. Crosstalk vs Frequency, 1SPW (BTL)

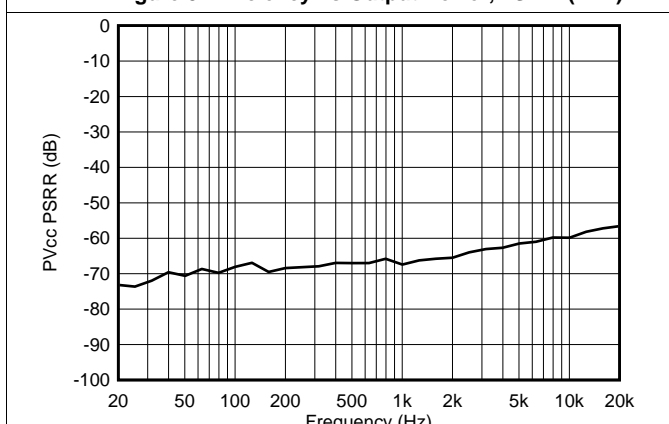

AVCC=PVCC = 12 V, Load = 4 Ω + 33 μH

Figure 11. Supply Ripple Rejection Ratio vs Frequency (BTL)

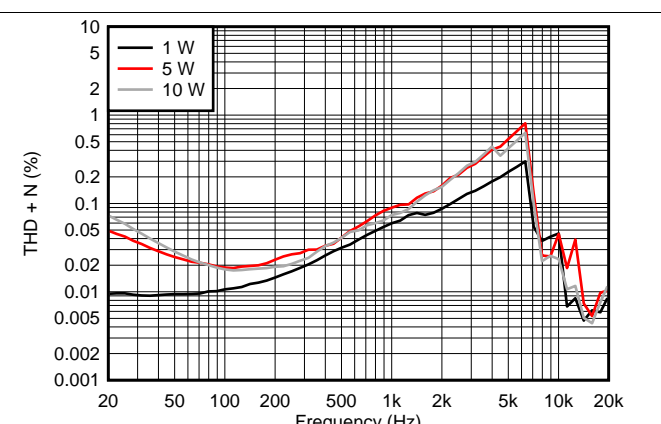

AVCC=PVCC = 13 V, Load = 4 Ω + 33 μH, 1 W, 2.5 W, 10 W

Figure 12. Total Harmonic Distortion + Noise vs Frequency, 1SPW (PBTTL)

Typical Characteristics (continued)

All Measurements taken at 20dB closed loop gain, 1-kHz audio, $T_A = 25^\circ\text{C}$ unless otherwise noted. Measurements were made with AES17 filter using the TPA3140D2 EVM, which is available at ti.com.

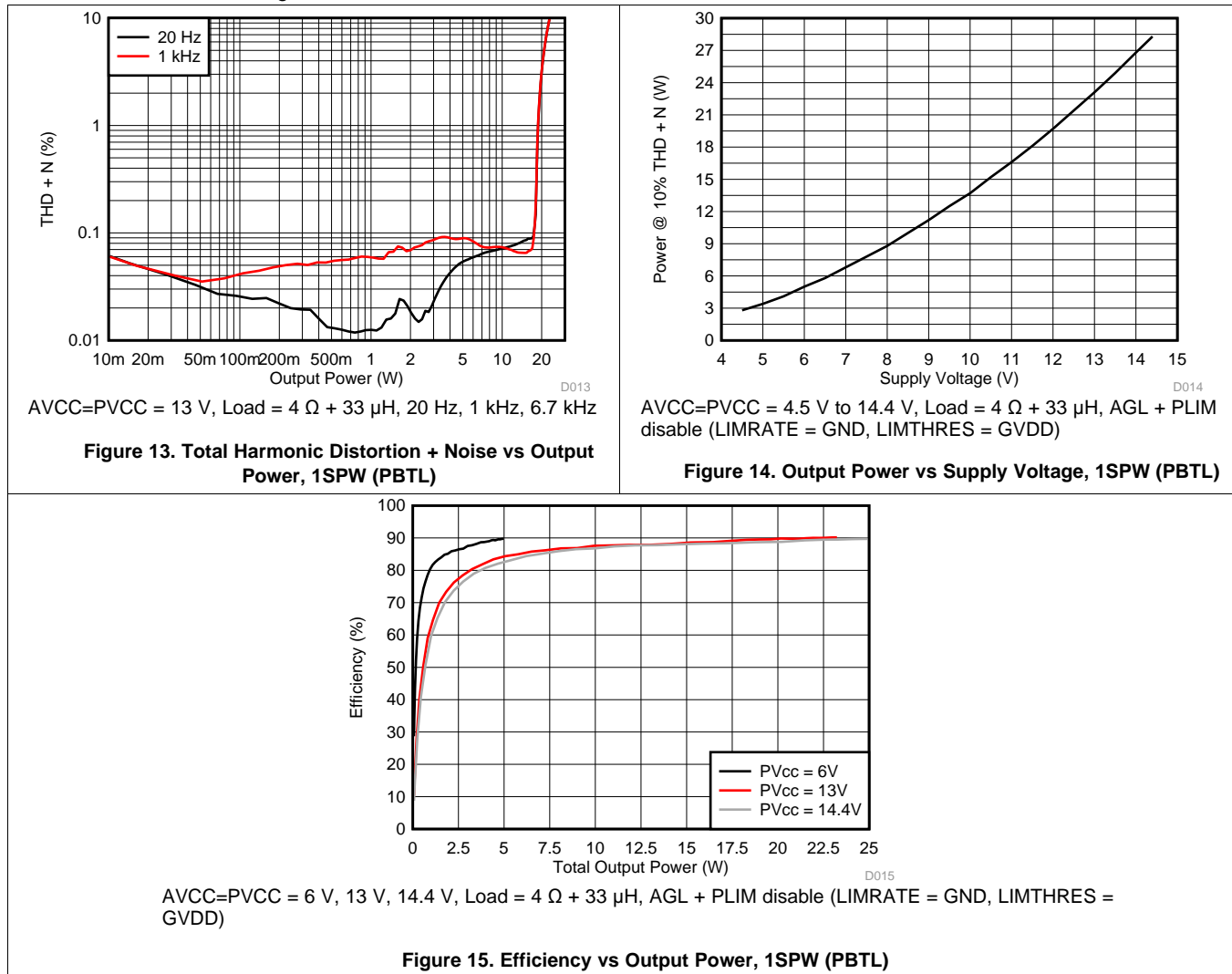

9 Parameter Measurement Information

All parameters are measured according to the conditions described in the [Specifications](#) and [Typical Characteristics](#).

Most audio analyzers will not give correct readings of Class-D amplifiers' performance due to their sensitivity to out of band noise present at the amplifier output. An AES-17 pre analyzer filter is recommended to use for Class-D amplifier measurements. In absence of such filter, a 30kHz low-pass filter (10Ω + 47nF) can be used to reduce the out of band noise remaining on the amplifier outputs.

10 Detailed Description

10.1 Overview

To facilitate system design, the TPA3140D2 needs only a single power supply between 4.5 V and 14.4 V for operation. An internal voltage regulator provides suitable voltage levels for the gate driver, digital and low-voltage analog circuitry. Additionally, all circuitry requiring a floating voltage supply, that is, the high-side gate drive, is accommodated by built-in bootstrap circuitry with integrated boot strap diodes requiring only an external capacitor for each half-bridge.

The audio signal path, including the gate drive and output stage is designed as identical, independent full-bridges. Special attention should be paid to placing all decoupling capacitors as close to their associated pins as possible. In general, the physical loop with the power supply pins, decoupling capacitors and GND return path to the device pins must be kept as short as possible and with as little area as possible to minimize induction (see reference board documentation for additional information).

For a properly functioning bootstrap circuit, a small ceramic capacitor must be connected from each bootstrap pin (BSXX) to the power-stage output pin (OUTXX). When the power-stage output is low, the bootstrap capacitor is charged through an internal diode connected between the gate-drive power-supply pin (GVDD) and the bootstrap pins. When the power-stage output is high, the bootstrap capacitor potential is shifted above the output potential and thus provides a suitable voltage supply for the high-side gate driver. In an application with PWM switching frequencies in the range from 310 kHz, it is recommended to use ceramic capacitors with at least 220-nF capacitance, size 0603 or 0805, for the bootstrap supply. These capacitors ensure sufficient energy storage, even during clipped low frequency audio signals, to keep the high-side power stage FET (LDMOS) fully turned on during the remaining part of its ON cycle.

Special attention should be paid to the power-stage power supply; this includes component selection, PCB placement, and routing. For optimal electrical performance, EMI compliance, and system reliability, it is important that each PVCC pin is decoupled with ceramic capacitors placed as close as possible to each supply pin. It is recommended to follow the PCB layout of the TPA3140D2 reference design. For additional information on recommended power supply and required components, see the application diagrams in this data sheet.

The PVCC power supply should have low output impedance and low noise. The power-supply ramp and \overline{SD} release sequence is not critical for device reliability as facilitated by the internal power-on-reset circuit, but it is recommended to release \overline{SD} after the power supply is settled for minimum turn on audible artifacts.

10.2 Functional Block Diagram

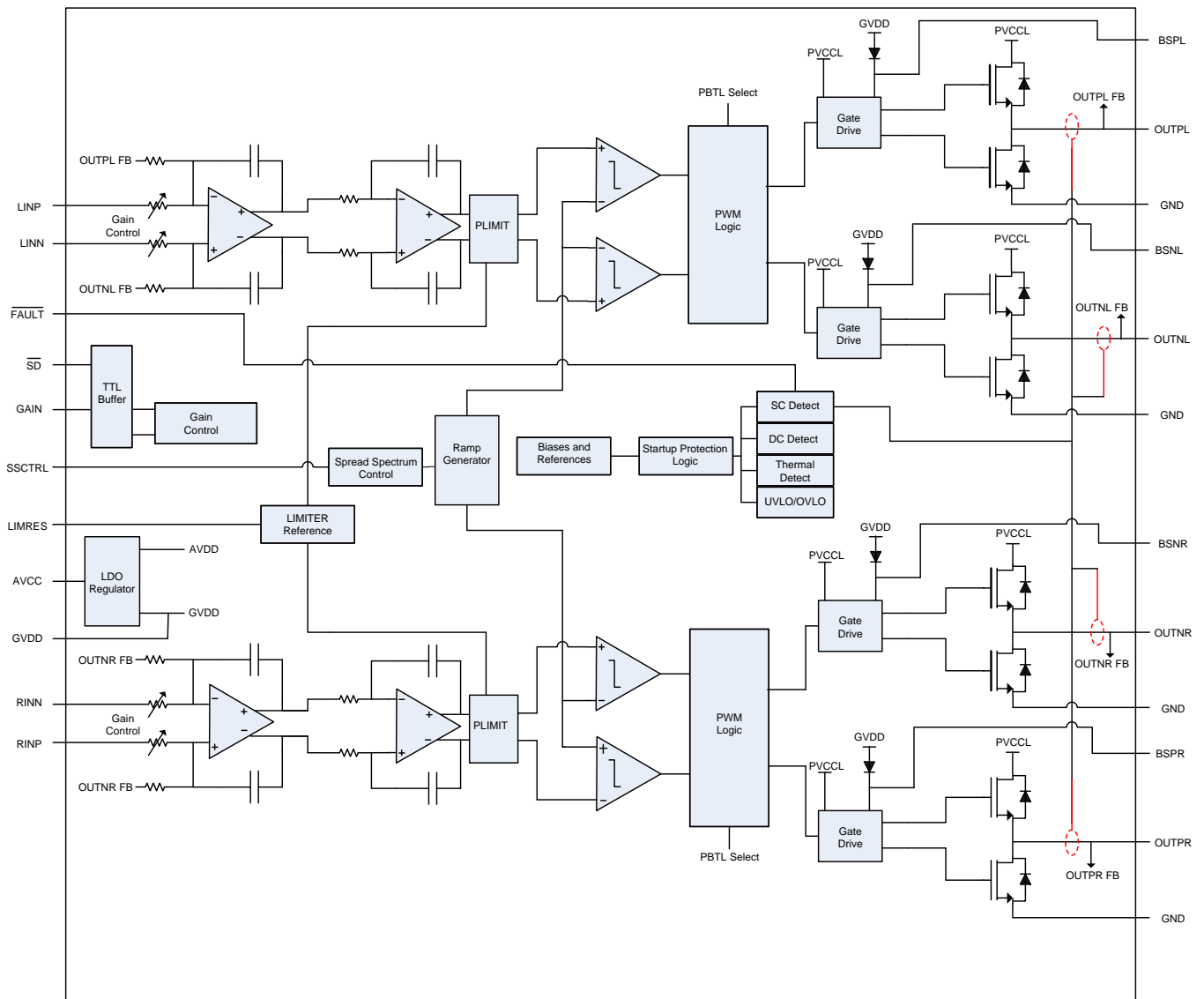

10.3 Feature Description

10.3.1 Gain Setting via GAIN Pin

The gain of the TPA3140D2 is set by a voltage applied to the GAIN pin, which is set by a resistor voltage divider with GVDD as supply voltage. The resistance of the voltage divider should be a minimum of 100 kΩ in order not to overload the GVDD regulator of TPA3140D2.

Feature Description (continued)

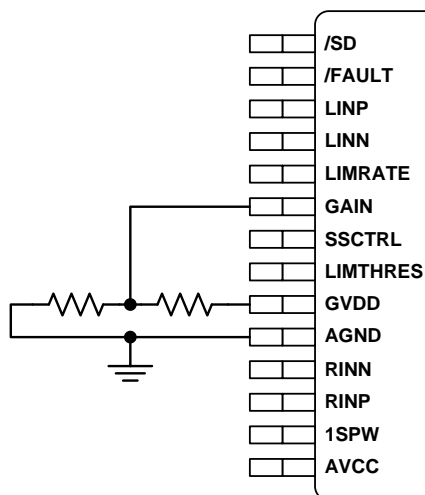

Figure 16. GAIN Pin Voltage Programming by GVDD Resistor Divider

The gains listed in Table 1 are realized by changing the taps on the input resistors and feedback resistors inside the amplifier. This causes the input impedance (Z_i) to be dependent on the gain setting. The actual gain settings are controlled by ratios of resistors, so the gain variation from part-to-part is small. However, the input impedance from part-to-part at the same gain may shift by $\pm 20\%$ due to shifts in the actual resistance of the input resistors. The selected input gain is latched at device start up and cannot be changed when \overline{SD} is high.

For design purposes, the input network (discussed in the next section) should be designed assuming an input impedance of 7.2 k Ω , which is the absolute minimum input impedance of the TPA3140D2. At the lower gain settings, the input impedance could increase as high as 72 k Ω .

Table 1. Gain Setting

GAIN PIN VOLTAGE	AMPLIFIER GAIN (dB)	INPUT IMPEDANCE (k Ω)
	TYP	TYP
0 V (GND)	20	60
2.3 V (1/3·GVDD)	26	30
4.6 V (2/3·GVDD)	32	15
6.9 V (GVDD)	36	9

10.3.2 \overline{SD} Operation

The TPA3140D2 employs a shutdown mode of operation designed to reduce supply current (I_{CC}) to the absolute minimum level during periods of nonuse for power conservation. The \overline{SD} input pin should be held high (see specification table for trip point) during normal operation when the amplifier is in use. Pulling \overline{SD} low causes the outputs to mute and the amplifier to enter a low-current state. Never leave \overline{SD} unconnected, because amplifier operation would be unpredictable.

For the best power-off pop performance, place the amplifier in the shutdown mode prior to removing the power supply voltage.

10.3.3 Gain Limit Control, LIMTHRES and LIMRATE

The TPA3140D2 has built-in gain limiters with two operation modes for load and system protection: Voltage limiting and temperature limiting. The voltage limiting mode controls the TPA3140D2 voltage gain to limit the output signal without signal clipping, and the temperature control mode limits the device power dissipation to keep the die temperature within recommended operating conditions. Both voltage limiter and thermal limiter attack and release speeds (time per 0.5dB gain step) are controlled by the LIMRATE pin:

Table 2. Speaker Guard AGL Settings

LIMRATE VOLTAGE	MODE	AGL ATTACK TIME	TFB ATTACK TIME	AGL/TFB RELEASE TIME
GVDD	FAST	40 μ s	200ms	400ms
2/3-GVDD	MEDIUM	80 μ s	400ms	800ms
1/3-GVDD	SLOW	160 μ s	800ms	1600ms
GND	PLIMIT	DISABLED	DISABLED	DISABLED

LIMRATE accepts a 4-level input signal to setup operation. When LIMRATE is connected to GND, the voltage limiter function is changed to a hard clip action to control the maximum output voltage.

10.3.4 SPEAKERGUARD Automatic Gain Limit, AGL

The TPA3140D2 has a built-in SpeakerGuard AGL to limit excessive output voltage to a non clipping output signal. When an excessive level input signal is sent to TPA3140D2 the SpeakerGuard AGL will automatically reduce the amplifier gain to maintain maximum unclipped output signal to preserve high audio quality and to protect the attached speaker from excessive power. The AGL works with a fast attack speed and a slower release speed to achieve maximum protection and a minimum number of audible artifacts.

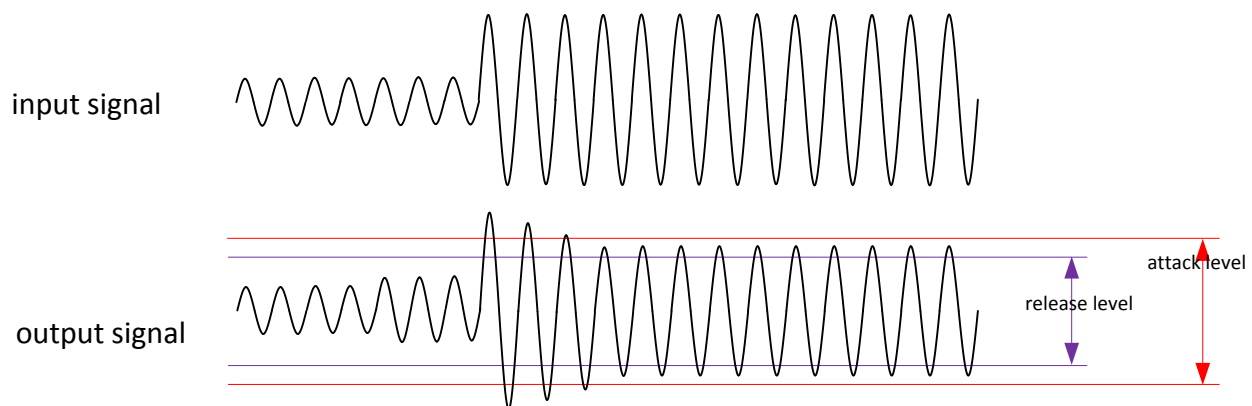
Figure 17. AGL Attack and Release Thresholds

When the input level multiplied by the TPA3140D2 closed loop gain exceeds the limiter threshold set by the LIMTHRES pin voltage, the TPA3140D2 closed loop gain is reduced in a single or by multiple 0.5dB steps until the output signal voltage gets below the level set by the LIMTHRES pin voltage, or if a -12.0dB gain reduction limit is reached. When the output voltage gets below the release threshold, the TPA3140D2 closed loop gain is increased by a single or by multiple 0.5dB steps until the release threshold is reached, or the closed loop gain is at its nominal closed loop gain level. The AGL gain adjustment is applied with a ramp speed selectable by the LIMRATE pin setting.

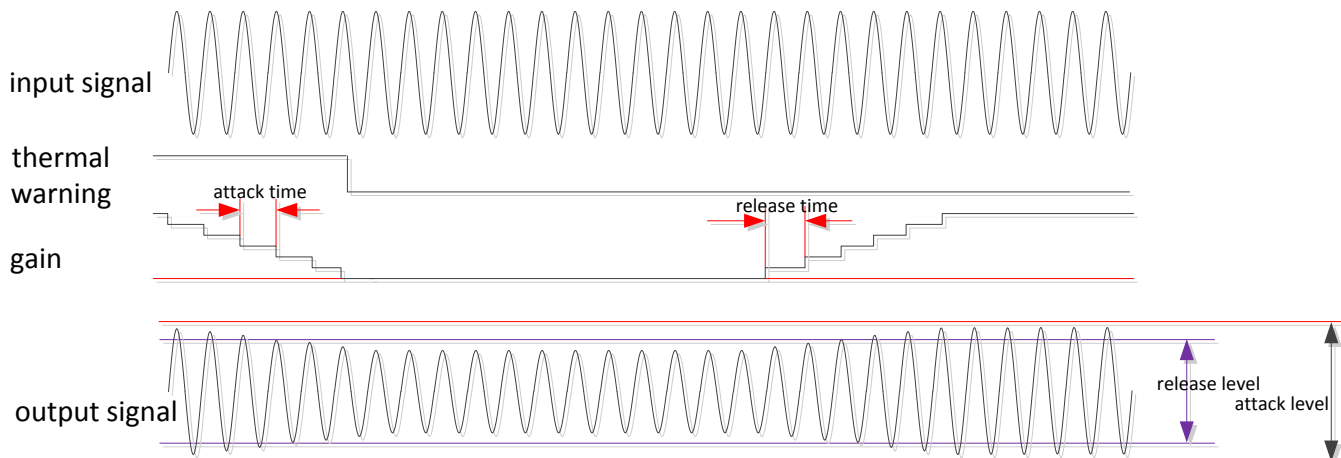

Figure 18. AGL Attack and Release Slopes

10.3.5 Thermal Foldback, TFB

The TPA3140D2 Thermal Foldback, TFB, is designed to protect the TPA3140D2 from excessive die temperature in case of the device being operated beyond the recommended temperature or power limit, or with a weaker thermal system than recommended. The TFB works by reducing the on die power dissipation by reducing the TPA3140D2 closed loop gain in steps of 0.5dB if the temperature trig point is exceeded. Once the die temperature drops below the TFB trig point, the TPA3140D2 closed loop gain is increased by a single or by multiple 0.5dB steps until the TFB trig point, or a maximum of 12dB attenuation is reached, and the closed loop gain will be decreased again, or the closed loop gain is at its nominal closed loop gain level. The TFB gain adjustment is applied with a ramp speed selectable by the LIMRATE pin setting as shown in Table 2.

10.3.6 PLIMIT

The PLIMIT operation will, if selected, limit the output voltage level to a voltage level below the supply rail. In this case the amplifier operates as if it was powered by a lower supply voltage, and thereby limiting the output power by voltage clipping. PLIMIT threshold is set by the LIMTHRES pin voltage.

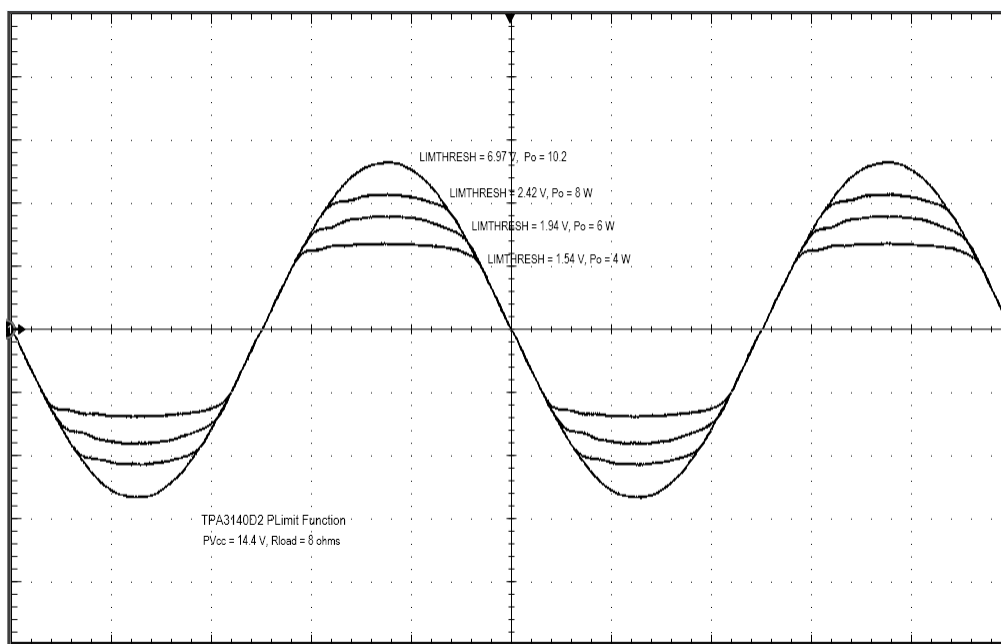

Figure 19. PLIMIT Circuit Operation

10.3.7 LIMTHRES

The AGL and PLIMIT voltage threshold is set by the applied LIMTHRES voltage. The LIMTHRES voltage is set by a voltage divider from GVDD to GND. The limiting is done by limiting the amplifier output voltage to a fixed maximum value. This limit can be thought of as a "virtual" voltage rail, which is lower than the PVCC supply. This virtual rail is 4 times the voltage at the LIMTHRES pin. This output voltage can be used to calculate the maximum output voltage (unclipped using AGL and clipped using PLIMIT) and power for a given LIMTHRES voltage and speaker impedance.

$$P_{OUT} = \frac{\left(\left(\frac{R_L}{R_L + 2 \cdot R_S} \right) \cdot V_P \right)^2}{2 \cdot R_L}, \quad \text{for unclipped power} \quad (1)$$

Where:

R_S is the total series resistance including $R_{DS(on)}$, and any resistance in the output filter.

R_L is the load resistance.

V_P is the peak amplitude of the output possible within the supply rail.

$V_P = 4 \times \text{LIMTHRES voltage}$ if $V_P < P_{VCC}$

$P_{OUT} = \text{Maximum unclipped output power. 10\%THD using PLIMIT: } 1.25 \times P_{MAX} \text{ (unclipped)}$

Increasing the LIMTHRES voltage from a given value increases the maximum output voltage swing until it equals PVCC. Adjusting LIMTHRES to a higher value will disable both the AGL and PLIMIT function and will offer highest available output power, however it is always advised to use the LIMTHRES function if PVCC is higher than the nominal value to prevent shutdown due to over current protection or to reduce frequency of thermal foldback events. To disable the AGL or PLIMIT function, the LIMTHRES pin is simply connected to GVDD.

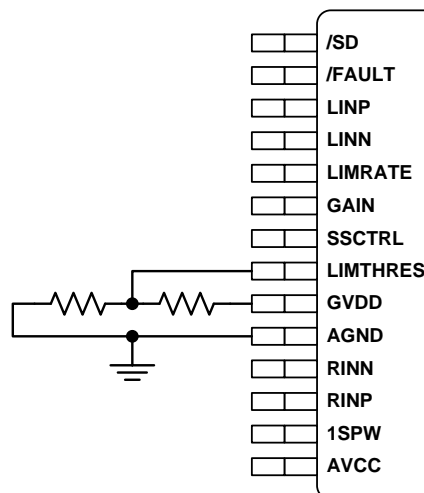
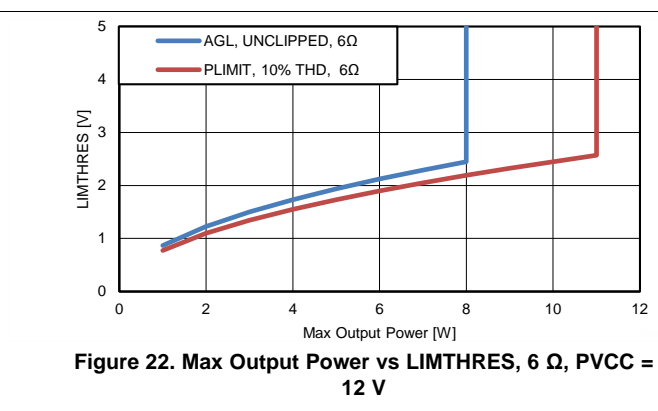
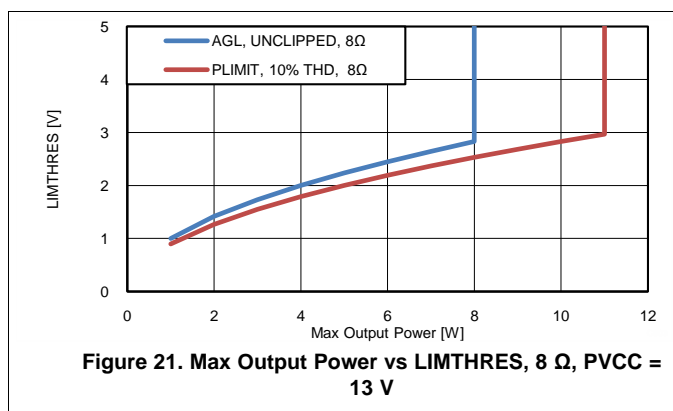

Figure 20. LIMHTRES Pin Voltage Programming by GVDD Resistor Divider

Table 3. LIMTHRES Typical Operation

TEST CONDITIONS ()	LIMTHRES VOLTAGE (V)	R to GND	R to GVDD	OUTPUT POWER (W), UNCLIPPED, AGL	OUTPUT POWER (W), 10% THD, PLIMIT
PVCC = 12 V, R _L = 6 Ω	1.9	33 kΩ	82 kΩ	4.75	6
PVCC = 12 V, R _L = 6 Ω	2.2	39 kΩ	82 kΩ	6.5	8
PVCC = 12 V, R _L = 6 Ω	2.5	39 kΩ	68 kΩ	8	10
PVCC = 14.4 V, R _L = 8 Ω	2.2	39 kΩ	82 kΩ	4.75	6
PVCC = 14.4 V, R _L = 8 Ω	2.5	39 kΩ	68 kΩ	6.5	8
PVCC = 14.4 V, R _L = 8 Ω	2.8	47 kΩ	68 kΩ	8	10



10.3.8 Spread Spectrum and De-Phase Control

The TPA3140 has built-in spread spectrum control of the oscillator frequency and de-phase of the PWM outputs to improve EMI performance. Two spread spectrum schemes can be selected, and for operation without spread spectrum, de-phase can be turned off.

De-phase inverts the phase of the output PWM such that the idle output PWM waveforms of the two audio channels are inverted. De-phase does not affect the audio signal, or its polarity.

Spread spectrum mode and de-phase is selected by the applied SSCTRL voltage.

Table 4. Gain Setting

SSCTRL PIN VOLTAGE	SPREAD SPECTRUM MODULATION	DE-PHASE
0 V (GND)	OFF	OFF
2.3 V (1/3-GVDD)	OFF	ON
4.6 V (2/3-GVDD)	SS1 MODULATION	ON
6.9 V (GVDD)	SS2 MODULATION	ON

10.3.9 GVDD Supply

The GVDD Supply is used to power the gates of the output full bridge transistors. It can also be used to supply the voltage divider circuits for LIMRATE, LIMTHRES, GAIN, and SSCTRL programming voltages.. Add a 1- μ F capacitor to ground at this pin.

10.3.10 DC Detect

The TPA3140D2 has circuitry which will protect the speakers from DC current which might occur due to defective capacitors on the input or shorts on the printed circuit board at the inputs. A DC detect fault will be reported on the FAULT pin as a low state. The DC Detect fault will also cause the amplifier to shutdown by changing the state of the outputs to Hi-Z. To clear the DC Detect it is necessary to cycle the PVCC supply. Cycling SD will NOT clear a DC detect fault.

A DC Detect Fault is issued when the output differential duty-cycle of either channel exceeds 14% (for example, +57%, -43%) for more than 950 msec at the same polarity. This feature protects the speaker from large DC currents or AC currents less than 2 Hz. To avoid nuisance faults due to the DC detect circuit, hold the SD pin low at power-up until the signals at the inputs are stable. Also, take care to match the impedance seen at the positive and negative inputs to avoid nuisance DC detect faults.

The minimum differential input voltages required to trigger the DC detect are show in [Table 5](#). The inputs must remain at or above the voltage listed in the table for more than 950 msec to trigger the DC detect.

Table 5. DC Detect Threshold, PVCC=12V

AV(dB)	Vin (mV, differential)	Vout (V, differential)
20	260	2.6
26	130	2.6
32	65	2.6
36	40	2.6

10.3.11 PBTL Select

The TPA3140D2 offers the feature of parallel BTL operation with two outputs of each channel connected directly. If the LINP and LINN input pins (pin 3 and 4) are tied low, the positive and negative outputs of each channel (left and right) are synchronized and in phase. To operate in this PBTL (mono) mode, tie LINP and LINN inputs low to GND and apply the input signal to the RINP and RINN inputs and place the speaker between the LEFT and RIGHT outputs with OUTPL connected to OUTNL and OUTPR connected to OUTNR to parallel the output half bridges for highest power efficiency. For an example of the PBTL connection, see the schematic in the [Typical Applications](#) section.

10.3.12 Short-Circuit Protection and Automatic Recovery Feature

The TPA3140D2 has protection from overcurrent conditions caused by a short circuit on the output stage. The short circuit protection fault is reported on the FAULT pin as a low state. The amplifier outputs are switched to a Hi-Z state when the short circuit protection latch is engaged. The latch can be cleared by cycling the SD pin through the low state.

If automatic recovery from the short circuit protection latch is desired, connect the $\overline{\text{FAULT}}$ pin directly to the $\overline{\text{SD}}$ pin. This allows the $\overline{\text{FAULT}}$ pin function to automatically drive the $\overline{\text{SD}}$ pin low which clears the short-circuit protection latch.

10.3.13 Thermal Protection

Thermal protection on the TPA3140D2 prevents damage to the device when the internal die temperature exceeds 150°C. There is a $\pm 15^\circ\text{C}$ tolerance on this trip point from device to device. Once the die temperature exceeds the thermal trip point, the device enters into the shutdown state and the outputs are disabled. This is a latched fault.

Thermal protection faults are reported on the $\overline{\text{FAULT}}$ pin.

If automatic recovery from the thermal protection latch is desired, connect the $\overline{\text{FAULT}}$ pin directly to the $\overline{\text{SD}}$ pin. This allows the $\overline{\text{FAULT}}$ pin function to automatically drive the $\overline{\text{SD}}$ pin low which clears the thermal protection latch.

10.4 Device Functional Modes

The TPA3140D2 has the option of running in either BD modulation or 1SPW modulation; this is set by the 1SPW pin.

1SPW = GND: BD-modulation

This is a modulation scheme that allows operation without the classic LC reconstruction filter when the amp is driving an inductive load with short speaker wires. Each output is switching from 0 volts to the supply voltage. The OUTPx and OUTNx are in phase with each other with no input so that there is little or no current in the speaker. The duty cycle of OUTPx is greater than 50% and OUTNx is less than 50% for positive output voltages. The duty cycle of OUTPx is less than 50% and OUTNx is greater than 50% for negative output voltages. The voltage across the load sits at 0V throughout most of the switching period, reducing the switching current, which reduces any I²R losses in the load.

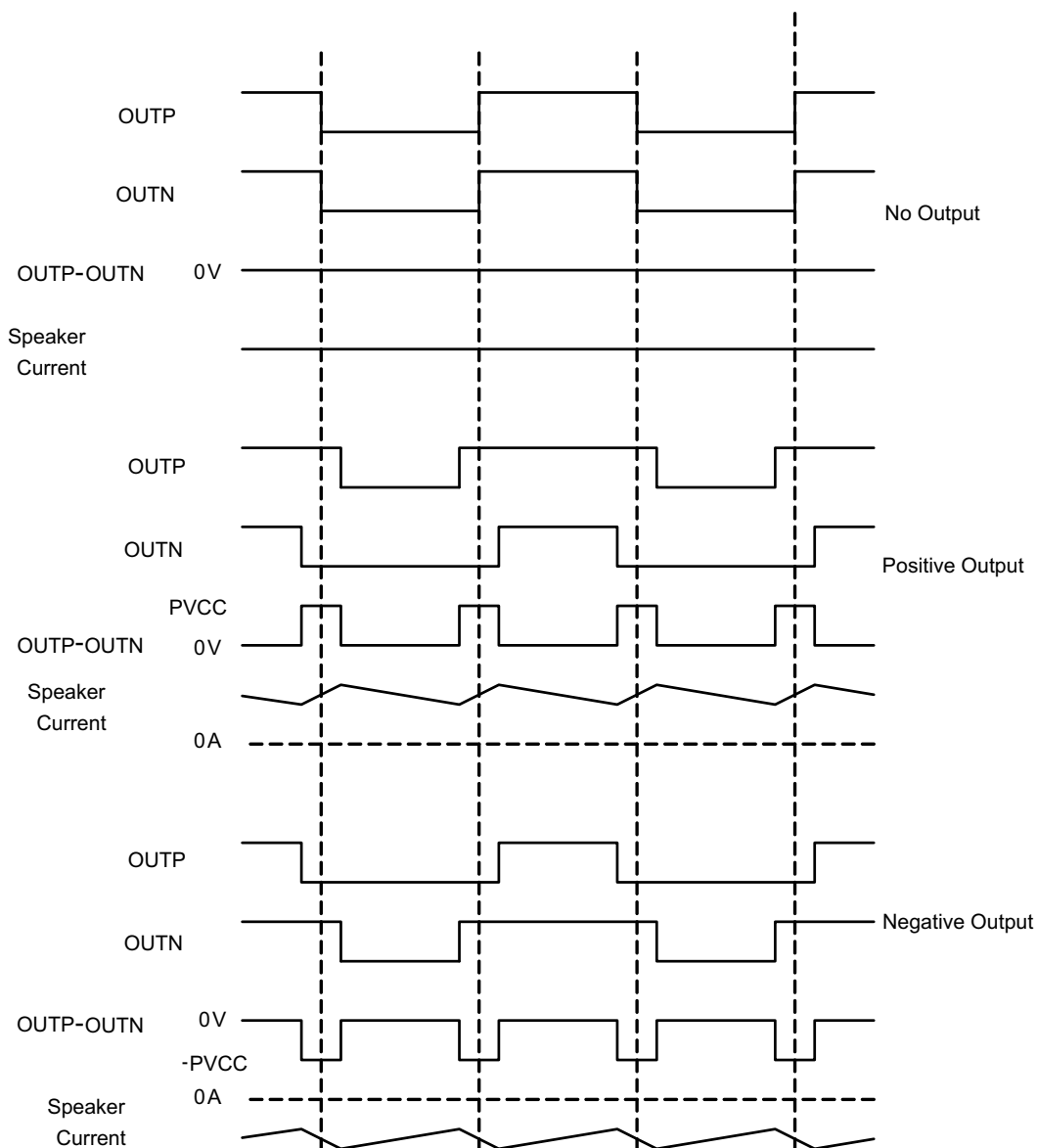
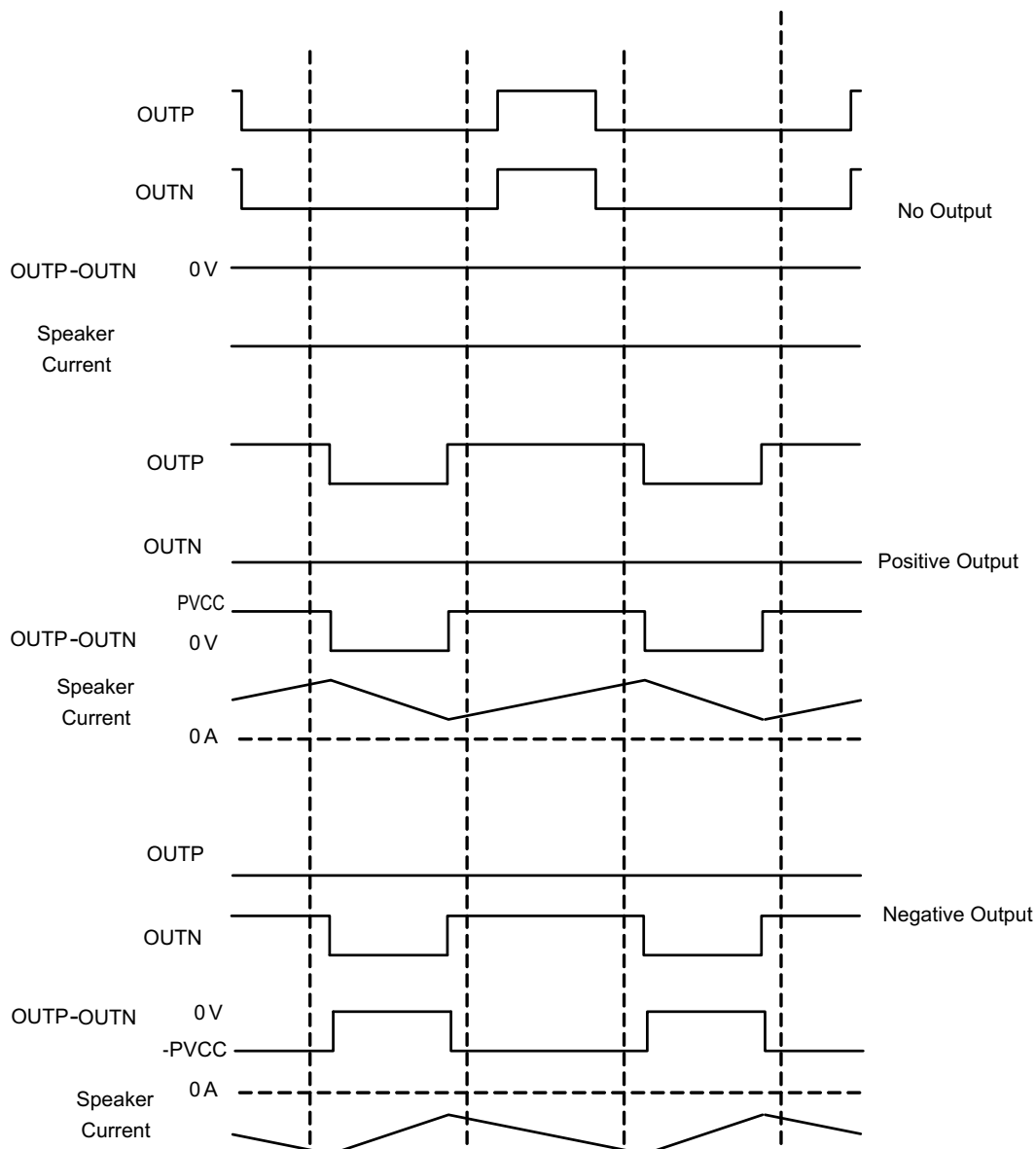

Figure 23. BD Mode Modulation

Device Functional Modes (continued)
1SPW = HIGH: 1SPW-modulation

The 1SPW mode alters the normal modulation scheme in order to achieve higher efficiency with a slight penalty in THD degradation and more attention required in the output filter selection. In 1SPW mode the outputs operate at ~15% modulation during idle conditions. When an audio signal is applied one output will decrease and one will increase. The decreasing output signal will quickly rail to GND at which point all the audio modulation takes place through the rising output. The result is that only one output is switching during a majority of the audio cycle. Efficiency is improved in this mode due to the reduction of switching losses. The THD penalty in 1SPW mode is minimized by the high performance feedback loop. The resulting audio signal at each half output has a discontinuity each time the output rails to GND. This can cause ringing in the audio reconstruction filter unless care is taken in the selection of the filter components and type of filter used.

Figure 24. 1SPW Mode Modulation

11 Application and Implementation

11.1 Application Information

The TPA3140D2 is designed for use in inductor free applications with limited distance wire length) between amplifier and speakers like in TV sets, sound docks and Bluetooth speakers. The TPA3140D2 can either be configured in stereo or mono mode, depending on output power conditions. Depending on output power requirements and necessity for (speaker) load protection, the built in AGL or PLIMIT circuit can be used to control system power, see functional description of these features.

11.2 Typical Applications

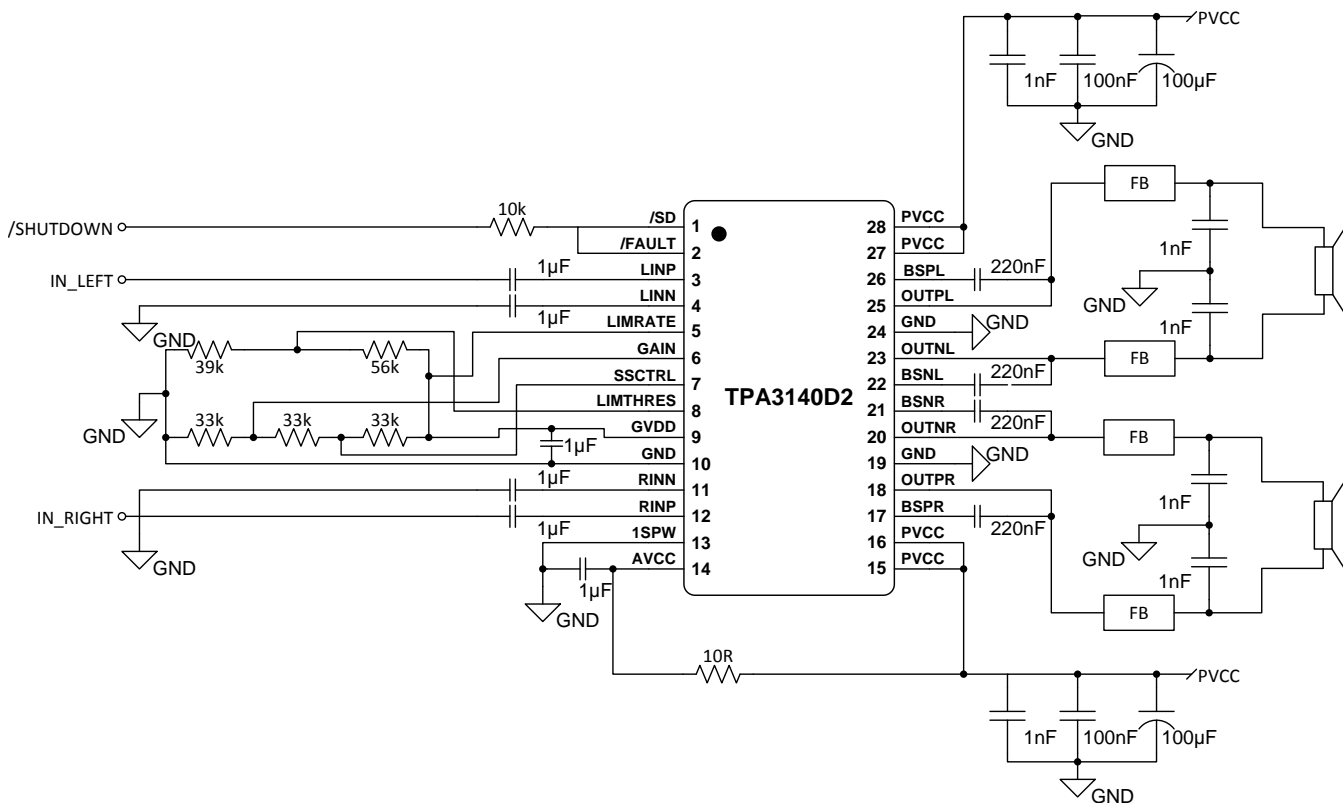
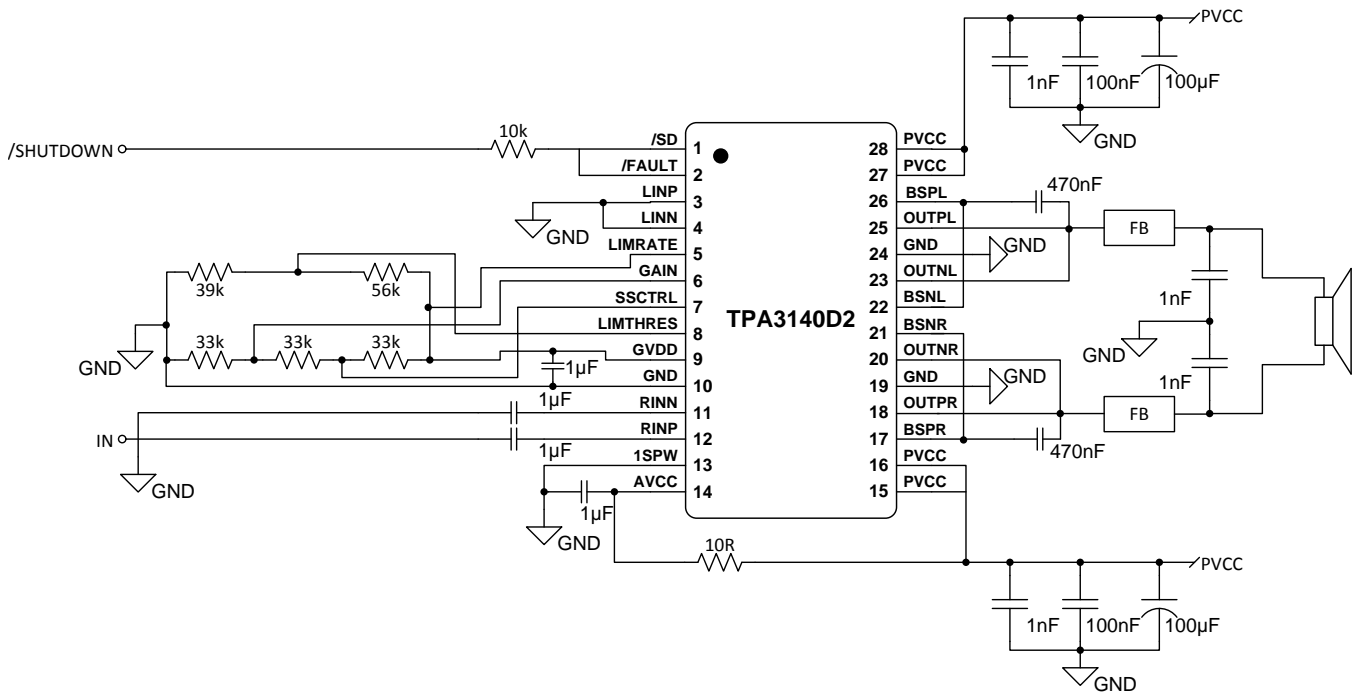

Figure 25. Stereo Class-D Amplifier with BTL Output and Single-Ended Inputs with Spread Spectrum Modulation

Typical Applications (continued)



(1) 100-kΩ resistor is needed if the PVCC slew rate is more than 10 V/ms.

Figure 26. Stereo Class-D Amplifier with PBTB Output and Single-Ended Input with Spread Spectrum Modulation

11.2.1 Design Requirements

11.2.1.1 PCB Material Recommendation

FR-4 Glass Epoxy material with 1 oz. (35 µm) is recommended for use with the TPA3140D2. The use of this material can provide for higher power output, improved thermal performance, and better EMI margin (due to lower PCB trace inductance). It is recommended to use several GND underneath the device thermal pad for thermal coupling to a bottom side copper GND plane for best thermal performance.

11.2.1.2 PVCC Capacitor Recommendation

The large capacitors used in conjunction with each full-bridge, are referred to as the PVCC Capacitors. These capacitors should be selected for proper voltage margin and adequate capacitance to support the power requirements. In practice, with a well designed system power supply, 100 µF, 16 V will support most applications with 12-V power supply. 25-V capacitor rating is recommended for power supply voltage higher than 12-V. For The PVCC capacitors should be low ESR type because they are used in a circuit associated with high-speed switching.

11.2.1.3 Decoupling Capacitor Recommendations

In order to design an amplifier that has robust performance, passes regulatory requirements, and exhibits good audio performance, good quality decoupling capacitors should be used. In practice, X7R should be used in this application.

The voltage of the decoupling capacitors should be selected in accordance with good design practices. Temperature, ripple current, and voltage overshoot must be considered. This fact is particularly true in the selection of the ceramic capacitors that are placed on the power supply to each full-bridge. They must withstand the voltage overshoot of the PWM switching, the heat generated by the amplifier during high power output, and the ripple current created by high power output. A minimum voltage rating of 16 V is required for use with a 12-V power supply.

Typical Applications (continued)

11.2.2 Detailed Design Procedure

A rising-edge transition on \overline{SD} input allows the device to start switching. It is recommended to ramp the PVCC voltage to its desired value before releasing \overline{SD} for minimum audible artefacts.

The device is non-inverting the audio signal from input to output.

The GVDD pin is not recommended to be used as a voltage source for external circuitry.

11.2.2.1 Ferrite Bead Filter Considerations

Using the Advanced Emissions Suppression Technology in the TPA3140D2 amplifier it is possible to design a high efficiency Class-D audio amplifier while minimizing interference to surrounding circuits. It is also possible to accomplish this with only a low-cost ferrite bead filter. In this case it is necessary to carefully select the ferrite bead used in the filter.

One important aspect of the ferrite bead selection is the type of material used in the ferrite bead. Not all ferrite material is alike, so it is important to select a material that is effective in the 10 to 100 MHz range which is key to the operation of the Class-D amplifier. Many of the specifications regulating consumer electronics have emissions limits as low as 30 MHz. It is important to use the ferrite bead filter to block radiation in the 30 MHz and above range from appearing on the speaker wires and the power supply lines which are good antennas for these signals. The impedance of the ferrite bead can be used along with a small capacitor with a value in the range of 1000 pF to reduce the frequency spectrum of the signal to an acceptable level. For best performance, the resonant frequency of the ferrite bead/ capacitor filter should be less than 10 MHz.

Also, it is important that the ferrite bead is large enough to maintain its impedance at the peak currents expected for the amplifier. Some ferrite bead manufacturers specify the bead impedance at a variety of current levels. In this case it is possible to make sure the ferrite bead maintains an adequate amount of impedance at the peak current the amplifier will see. If these specifications are not available, it is also possible to estimate the bead's current handling capability by measuring the resonant frequency of the filter output at low power and at maximum power. A change of resonant frequency of less than fifty percent under this condition is desirable. Examples of ferrite beads which have been tested and work well with the TPA3140D2 include NFZ2MSM series from Murata.

A high quality ceramic capacitor is also needed for the ferrite bead filter. A low ESR capacitor with good temperature and voltage characteristics will work best.

Additional EMC improvements may be obtained by adding snubber networks from each of the class D outputs to ground. Suggested values for a simple RC series snubber network would be 10 Ω in series with a 330-pF capacitor although design of the snubber network is specific to every application and must be designed taking into account the parasitic reactance of the printed circuit board as well as the audio amp. Take care to evaluate the stress on the component in the snubber network especially if the amp is running at high PVCC. Also, make sure the layout of the snubber network is tight and returns directly to the GND or the thermal pad beneath the chip.

11.2.2.2 Efficiency: LC Filter Required with the Traditional Class-D Modulation Scheme

The main reason that the traditional class-D amplifier needs an output filter is that the switching waveform results in maximum current flow. This causes more loss in the load, which causes lower efficiency. The ripple current is large for the traditional modulation scheme, because the ripple current is proportional to voltage multiplied by the time at that voltage. The differential voltage swing is $2 \times V_{CC}$, and the time at each voltage is half the period for the traditional modulation scheme. An ideal LC filter is needed to store the ripple current from each half cycle for the next half cycle, while any resistance causes power dissipation. The speaker is both resistive and reactive, whereas an LC filter is almost purely reactive.

The TPA3140D2 modulation scheme has little loss in the load without a filter because the pulses are short and the change in voltage is V_{CC} instead of $2 \times V_{CC}$. As the output power increases, the pulses widen, making the ripple current larger. Ripple current could be filtered with an LC filter for increased efficiency, but for most applications the filter is not needed.

An LC filter with a cutoff frequency less than the class-D switching frequency allows the switching current to flow through the filter instead of the load. The filter has less resistance but higher impedance at the switching frequency than the speaker, which results in less power dissipation, therefore increasing efficiency.

Typical Applications (continued)

11.2.2.3 When to Use an Output Filter for EMI Suppression

The TPA3140D2 has been tested with a simple ferrite bead filter for a variety of applications including long speaker wires up to 100 cm and high power. The TPA3140D2 EVM passes FCC Class B specifications under these conditions using twisted speaker wires. The size and type of ferrite bead can be selected to meet application requirements. Also, the filter capacitor can be increased if necessary with some impact on efficiency.

There may be a few circuit instances where it is necessary to add a complete LC reconstruction filter. These circumstances might occur if there are nearby circuits which are sensitive to noise. In these cases a classic second order Butterworth filter similar to those shown in the figures below can be used.

Some systems have little power supply decoupling from the AC line but are also subject to line conducted interference (LCI) regulations. These include systems powered by "wall warts" and "power bricks." In these cases, LC reconstruction filters can be the lowest cost means to pass LCI tests. Common mode chokes using low frequency ferrite material can also be effective at preventing line conducted interference.

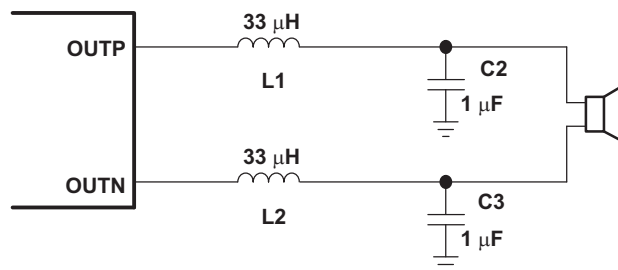

Figure 27. Typical LC Output Filter, Cutoff Frequency of 27 kHz, Speaker Impedance = 8 Ω

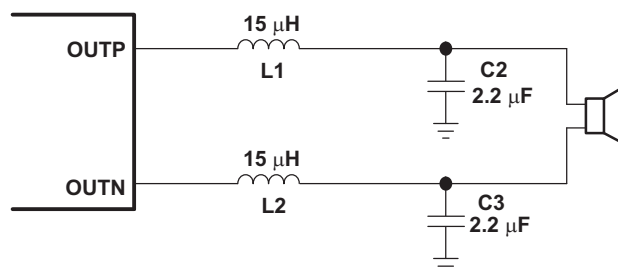

Figure 28. Typical LC Output Filter, Cutoff Frequency of 27 kHz, Speaker Impedance = 6 Ω

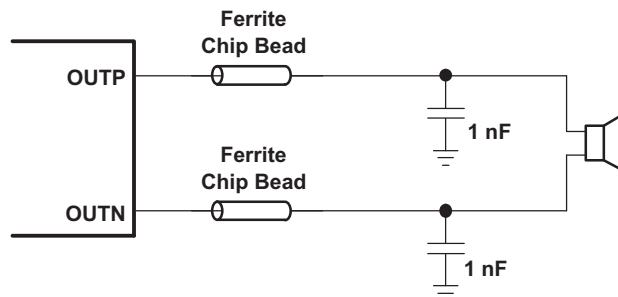
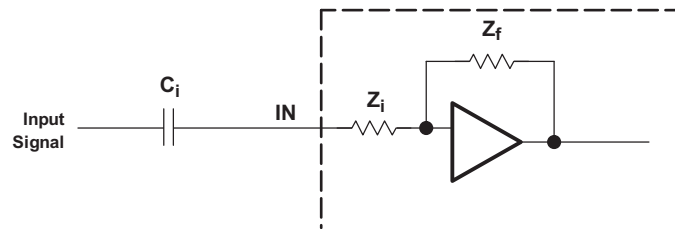

Figure 29. Typical Ferrite Chip Bead Filter (Chip Bead Example:)

11.2.2.4 Input Resistance

Changing the gain setting can vary the input resistance of the amplifier from its smallest value, 9 kΩ ±20%, to the largest value, 60 kΩ ±20%. As a result, if a single capacitor is used in the input high-pass filter, the -3 dB or cutoff frequency may change when changing gain steps.

Typical Applications (continued)



The -3-dB frequency can be calculated using Equation 2. Use the Z_i values given in Table 1.

$$f = \frac{1}{2\pi Z_i C_i} \quad (2)$$

11.2.2.5 Input Capacitor, C_i

In the typical application, an input capacitor (C_i) is required to allow the amplifier to bias the input signal to the proper dc level for optimum operation. In this case, C_i and the input impedance of the amplifier (Z_i) form a high-pass filter with the corner frequency determined in Equation 3.

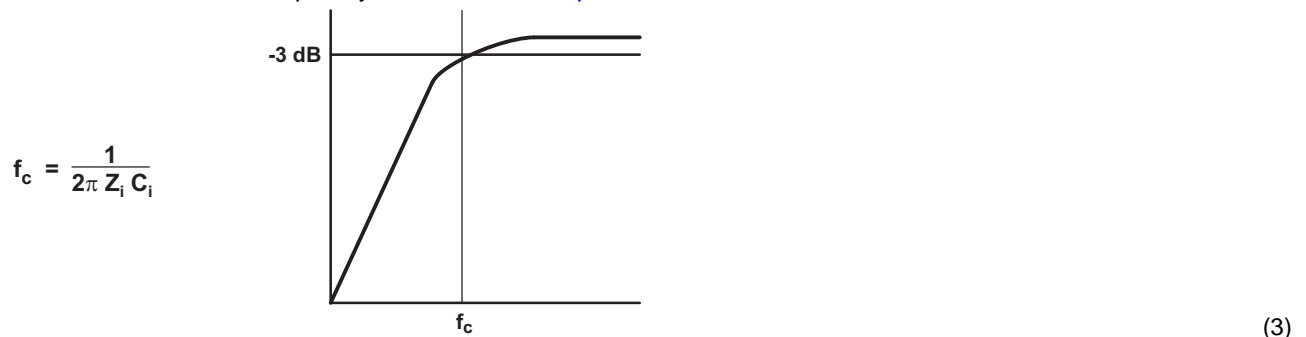

The value of C_i is important, as it directly affects the bass (low-frequency) performance of the circuit. Consider the example where Z_i is 60 k Ω and the specification calls for a flat bass response down to 20 Hz. Equation 3 is reconfigured as Equation 4.

$$C_i = \frac{1}{2\pi Z_i f_c} \quad (4)$$

In this example, C_i is 0.13 μF ; so, one would likely choose a value of 0.15 μF as this value is commonly used. If the gain is known and is constant, use Z_i from Table 1 to calculate C_i . A further consideration for this capacitor is the leakage path from the input source through the input network (C_i) and the feedback network to the load. This leakage current creates a dc offset voltage at the input to the amplifier that reduces useful headroom, especially in high gain applications. For this reason, a low-leakage tantalum or ceramic capacitor is the best choice. When polarized capacitors are used, the positive side of the capacitor should face the amplifier input in most applications as the dc level there is held at 3 V, which is likely higher than the source dc level. Note that it is important to confirm the capacitor polarity in the application. Additionally, lead-free solder can create dc offset voltages and it is important to ensure that boards are cleaned properly.

11.2.2.6 BSN and BSP Capacitors

The full H-bridge output stages use only NMOS transistors. Therefore, they require bootstrap capacitors for the high side of each output to turn on correctly. A 0.22- μF ceramic capacitor, rated for at least 25 V, must be connected from each output to its corresponding bootstrap input. Specifically, one 0.22- μF capacitor must be connected from OUTPx to BSPx, and one 0.22- μF capacitor must be connected from OUTNx to BSNx. (See the application circuit diagram in Figure 25.)

The bootstrap capacitors connected between the BSxx pins and corresponding output function as a floating power supply for the high-side N-channel power MOSFET gate drive circuitry. During each high-side switching cycle, the bootstrap capacitors hold the gate-to-source voltage high enough to keep the high-side MOSFETs turned on.

Typical Applications (continued)

11.2.2.7 Differential Inputs

The differential input stage of the amplifier cancels any noise that appears on both input lines of the channel. To use the TPA3140D2 with a differential source, connect the positive lead of the audio source to the INP input and the negative lead from the audio source to the INN input. To use the TPA3140D2 with a single-ended source, ac ground the INP or INN input through a capacitor equal in value to the input capacitor on INN or INP and apply the audio source to either input. In a single-ended input application, the unused input should be ac grounded at the audio source instead of at the device input for best noise performance. For good transient performance, the impedance seen at each of the two differential inputs should be the same.

The impedance seen at the inputs should be limited to an RC time constant of 1 ms or less if possible. This is to allow the input dc blocking capacitors to become completely charged during the 14 ms power-up time. If the input capacitors are not allowed to completely charge, there will be some additional sensitivity to component matching which can result in pop if the input components are not well matched.

11.2.2.8 Using Low-ESR Capacitors

Low-ESR capacitors are recommended throughout this application section. A real (as opposed to ideal) capacitor can be modeled simply as a resistor in series with an ideal capacitor. The voltage drop across this resistor minimizes the beneficial effects of the capacitor in the circuit. The lower the equivalent value of this resistance, the more the real capacitor behaves like an ideal capacitor.

Typical Applications (continued)

11.2.3 Application Performance Curves

11.2.3.1 EN55013 Radiated Emissions Results

TPA3140D2 EVM, PVCC = 12 V, 8-Ω load, up to 1 meter speaker cable, Spread Spectrum enabled, $P_O = 1.25\text{ W}$

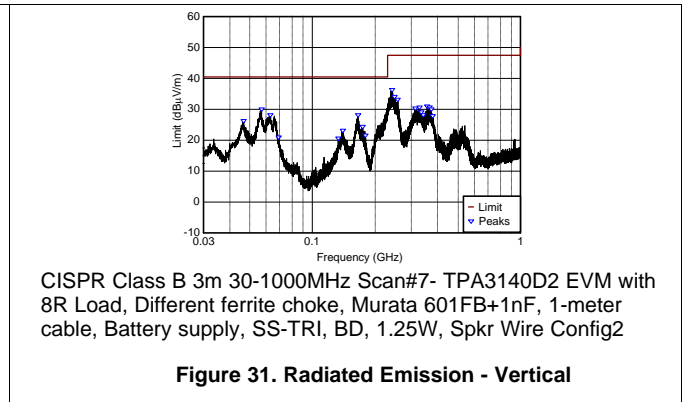
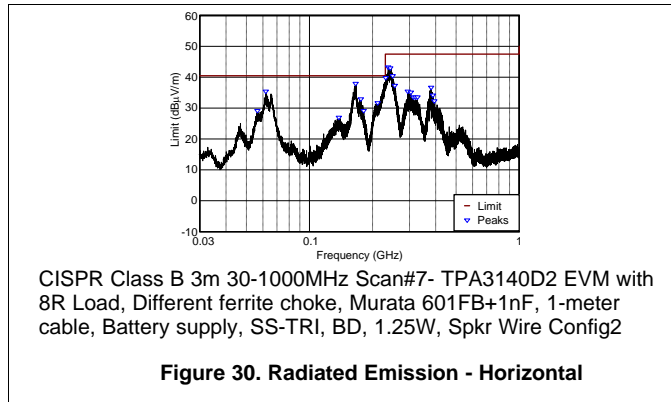

Table 6. Radiated Emission - Horizontal

FREQUENCY MHz	LIMIT dBμV/m	PEAKS dBμV/m	Q-PEAK dBμV/m	MARGIN dB	TURN TABLE DEGREES	TOWER cm
166.246	40.457	21.781	21.975	-18.482	44.9	100
237.372	47.457	29.330	29.186	-18.271	326.9	100

Table 7. Radiated Emission - Vertical

FREQUENCY MHz	LIMIT dBμV/m	PEAKS dBμV/m	Q-PEAK dBμV/m	MARGIN dB	TURN TABLE DEGREES	TOWER cm
56.841	40.457	26.213	27.058	-13.399	54	100
241.9	47.457	19.429	20.430	-27.027	-0.1	100

11.2.3.2 EN55022 Conducted Emissions Results

TV (40 inch) from the major TV manufacturer, TPA3140D2 EVM, PVCC = 12 V, 8-Ω speakers, Spread Spectrum enabled, $P_O = 1.25\text{ W}$

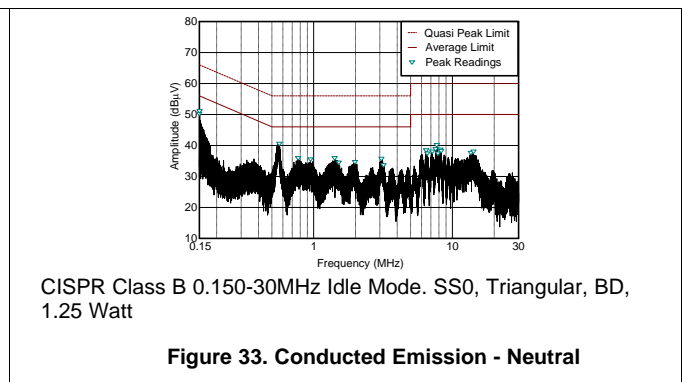
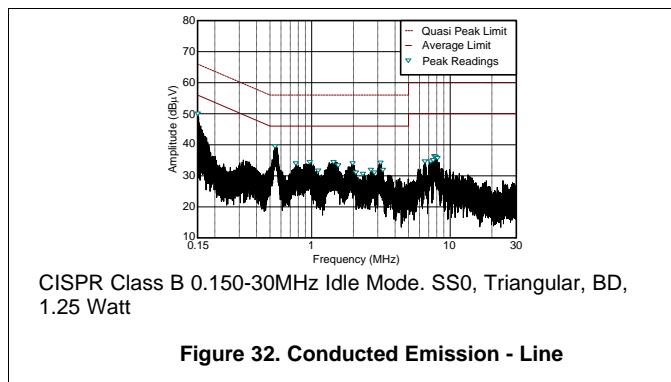

Table 8. Conducted Emission - Line

FREQUENCY MHz	QP LIMIT dBμV	AVE LIMIT dBμV	AVE READINGS dBμV	AVE MARGIN dB	QP READINGS dBμV	QP MARGIN dB
0.156	65.83	55.83	33.774	-22.056	45.956	-19.873
0.552	56	46	28.872	-17.128	39.164	-16.836
0.806	56	46	21.341	-24.659	29.585	-26.415
0.95	56	46	22.678	-23.322	31.471	-24.529
1.485	56	46	22.622	-23.378	31.082	-24.918
1.976	56	46	20.952	-25.048	29.849	-26.151

Table 9. Conducted Emission - Neutral

FREQUENCY MHz	QP LIMIT dBμV	AVE LIMIT dBμV	AVE READINGS dBμV	AVE MARGIN dB	QP READINGS dBμV	QP MARGIN dB
0.158	65.785	55.785	34.022	-21.763	45.398	-20.387
0.554	56	46	29.574	-16.426	40.485	-15.515
0.735	56	46	22.652	-23.348	32.52	-23.48
0.918	56	46	22.699	-23.301	31.849	-24.151
1.402	56	46	23.264	-22.736	32.173	-23.827
7.806	60	50	28.006	-21.994	35.214	-24.786

12 Power Supply Recommendations

12.1 Power Supply Decoupling, C_s

The TPA3140D2 is a high-performance CMOS audio amplifier that requires adequate power supply decoupling to ensure that the output total harmonic distortion (THD) is as low as possible. Power supply decoupling also prevents oscillations for long lead lengths between the amplifier and the speaker. Optimum decoupling is achieved by using a network of capacitors of different types that target specific types of noise on the power supply leads. For higher frequency transients due to parasitic circuit elements such as bond wire and copper trace inductances as well as lead frame capacitance, a good quality low equivalent-series-resistance (ESR) ceramic capacitor of value between 220 pF and 1000 pF works well. This capacitor should be placed as close to the device PVCC pins and system ground (either GND pins or thermal pad) as possible. For mid-frequency noise due to filter resonances or PWM switching transients as well as digital hash on the line, another good quality capacitor typically 0.1 μ F to 1 μ F placed as close as possible to the device PVCC leads works best. For filtering lower frequency noise signals, a larger aluminum electrolytic capacitor of 220 μ F or greater placed near the audio power amplifier is recommended. The 220- μ F capacitor also serves as a local storage capacitor for supplying current during large signal transients on the amplifier outputs. The PVCC pins provide the power to the output transistors, so a 220- μ F or larger capacitor should be placed on each PVCC pin. A 10- μ F capacitor on the AVCC pin is adequate. Also, a small decoupling resistor between AVCC and PVCC can be used to keep high frequency class-D noise from entering the linear input amplifiers.

13 Layout

13.1 Layout Guidelines

The TPA3140D2 can be used with a small, inexpensive ferrite bead output filter for most applications. However, since the Class-D switching edges are fast, it is necessary to take care when planning the layout of the printed circuit board. The following suggestions will help to meet EMC requirements.

- Decoupling capacitors—The high-frequency decoupling capacitors should be placed as close to the PVCC and AVCC pins as possible. Large (220 μ F or greater) bulk power supply decoupling capacitors should be placed near the TPA3140D2 on the PVCCL and PVCCR supplies. Local, high-frequency bypass capacitors should be placed as close to the PVCC pins as possible. These caps can be connected to the thermal pad directly for an excellent ground connection. Consider adding a small, good quality low ESR ceramic capacitor between 220 pF and 1000 pF and a larger mid-frequency cap of value between 0.1 μ F and 1 μ F also of good quality to the PVCC connections at each end of the chip.
- Keep the current loop from each of the outputs through the ferrite bead and the small filter cap and back to GND as small and tight as possible. The size of this current loop determines its effectiveness as an antenna.
- Grounding—The AVCC (pin 14) decoupling capacitor should be connected to ground (GND). The PVCC decoupling capacitors should connect to GND. Analog ground and power ground should be connected at the thermal pad, which should be used as a central ground connection or star ground for the TPA3140D2.
- Output filter—The ferrite EMI filter ([Figure 29](#)) should be placed as close to the output pins as possible for the best EMI performance. The LC filter ([Figure 27](#) and [Figure 28](#)) should be placed close to the outputs. The capacitors used in both the ferrite and LC filters should be grounded to power ground.
- Thermal Pad—The thermal pad must be soldered to the PCB for proper thermal performance and optimal reliability. The dimensions of the thermal pad and thermal land should be 6.46 mm by 2.35 mm. Seven rows of solid vias (three vias per row, 0,3302 mm or 13 mils diameter) should be equally spaced underneath the thermal land. The vias should connect to a solid copper plane, either on an internal layer or on the bottom layer of the PCB. The vias must be solid vias, not thermal relief or webbed vias. See the TI Application Report [SLMA002](#) for more information about using the TSSOP thermal pad. For recommended PCB footprints, see figures at the end of this data sheet.

For an example layout, see the TPA3140D2 Evaluation Module (TPA3140D2EVM) User Manual. Both the EVM user manual and the thermal pad application report are available on the TI Web site at <http://www.ti.com>.

13.2 Layout Example

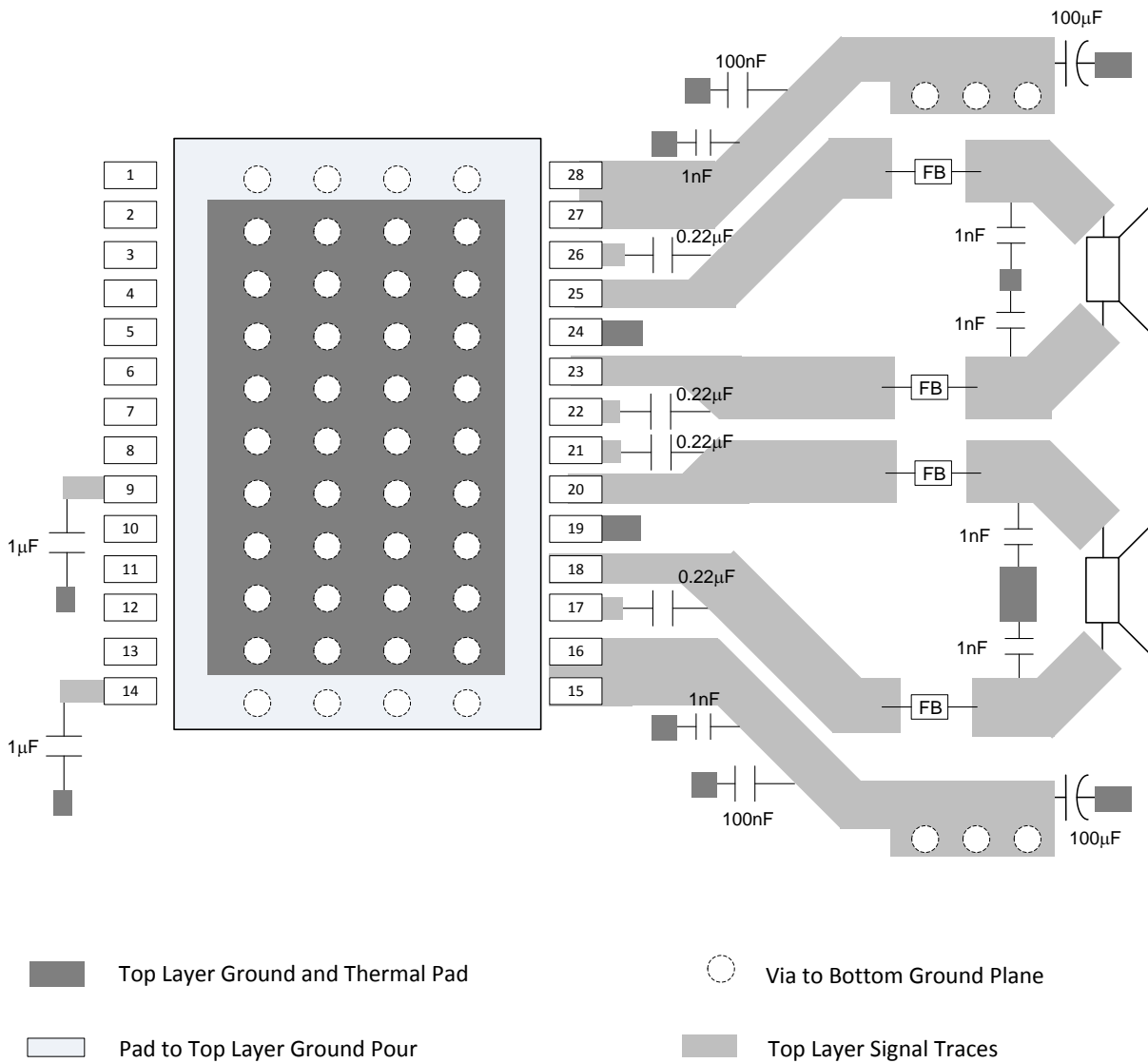

Figure 34. BTL Layout Example

14 Device and Documentation Support

14.1 Device Support

14.1.1 Third-Party Products Disclaimer

TI'S PUBLICATION OF INFORMATION REGARDING THIRD-PARTY PRODUCTS OR SERVICES DOES NOT CONSTITUTE AN ENDORSEMENT REGARDING THE SUITABILITY OF SUCH PRODUCTS OR SERVICES OR A WARRANTY, REPRESENTATION OR ENDORSEMENT OF SUCH PRODUCTS OR SERVICES, EITHER ALONE OR IN COMBINATION WITH ANY TI PRODUCT OR SERVICE.

14.2 Documentation Support

14.2.1 Related Documentation

TPA3140D2EVM User's Guide ([SLOU405](#))

PowerPAD™ Thermally Enhanced Package Application Report ([SLMA002](#))

14.3 Community Resources

The following links connect to TI community resources. Linked contents are provided *AS IS* by the respective contributors. They do not constitute TI specifications and do not necessarily reflect TI's views; see TI's [Terms of Use](#).

TI E2E™ Online Community *TI's Engineer-to-Engineer (E2E) Community*. Created to foster collaboration among engineers. At [e2e.ti.com](#), you can ask questions, share knowledge, explore ideas and help solve problems with fellow engineers.

Design Support *TI's Design Support* Quickly find helpful E2E forums along with design support tools and contact information for technical support.

14.4 Trademarks

SpeakerGuard, E2E are trademarks of Texas Instruments.
All other trademarks are the property of their respective owners.

14.5 Electrostatic Discharge Caution



These devices have limited built-in ESD protection. The leads should be shorted together or the device placed in conductive foam during storage or handling to prevent electrostatic damage to the MOS gates.

14.6 Glossary

[SLYZ022](#) — *TI Glossary*.

This glossary lists and explains terms, acronyms, and definitions.

15 Mechanical, Packaging, and Orderable Information

The following pages include mechanical, packaging, and orderable information. This information is the most current data available for the designated devices. This data is subject to change without notice and revision of this document. For browser-based versions of this data sheet, refer to the left-hand navigation.

PACKAGING INFORMATION

Orderable Device	Status (1)	Package Type	Package Drawing	Pins	Package Qty	Eco Plan (2)	Lead/Ball Finish (6)	MSL Peak Temp (3)	Op Temp (°C)	Device Marking (4/5)	Samples
TPA3140D2PWP	ACTIVE	HTSSOP	PWP	28	50	Green (RoHS & no Sb/Br)	CU NIPDAU	Level-3-260C-168 HR	-40 to 85	TPA3140D2	Samples
TPA3140D2PWPR	ACTIVE	HTSSOP	PWP	28	2000	Green (RoHS & no Sb/Br)	CU NIPDAU	Level-3-260C-168 HR	-40 to 85	TPA3140D2	Samples

(1) The marketing status values are defined as follows:

ACTIVE: Product device recommended for new designs.

LIFEBUY: TI has announced that the device will be discontinued, and a lifetime-buy period is in effect.

NRND: Not recommended for new designs. Device is in production to support existing customers, but TI does not recommend using this part in a new design.

PREVIEW: Device has been announced but is not in production. Samples may or may not be available.

OBsolete: TI has discontinued the production of the device.

(2) Eco Plan - The planned eco-friendly classification: Pb-Free (RoHS), Pb-Free (RoHS Exempt), or Green (RoHS & no Sb/Br) - please check <http://www.ti.com/productcontent> for the latest availability information and additional product content details.

TBD: The Pb-Free/Green conversion plan has not been defined.

Pb-Free (RoHS): TI's terms "Lead-Free" or "Pb-Free" mean semiconductor products that are compatible with the current RoHS requirements for all 6 substances, including the requirement that lead not exceed 0.1% by weight in homogeneous materials. Where designed to be soldered at high temperatures, TI Pb-Free products are suitable for use in specified lead-free processes.

Pb-Free (RoHS Exempt): This component has a RoHS exemption for either 1) lead-based flip-chip solder bumps used between the die and package, or 2) lead-based die adhesive used between the die and leadframe. The component is otherwise considered Pb-Free (RoHS compatible) as defined above.

Green (RoHS & no Sb/Br): TI defines "Green" to mean Pb-Free (RoHS compatible), and free of Bromine (Br) and Antimony (Sb) based flame retardants (Br or Sb do not exceed 0.1% by weight in homogeneous material)

(3) MSL, Peak Temp. - The Moisture Sensitivity Level rating according to the JEDEC industry standard classifications, and peak solder temperature.

(4) There may be additional marking, which relates to the logo, the lot trace code information, or the environmental category on the device.

(5) Multiple Device Markings will be inside parentheses. Only one Device Marking contained in parentheses and separated by a "~" will appear on a device. If a line is indented then it is a continuation of the previous line and the two combined represent the entire Device Marking for that device.

(6) Lead/Ball Finish - Orderable Devices may have multiple material finish options. Finish options are separated by a vertical ruled line. Lead/Ball Finish values may wrap to two lines if the finish value exceeds the maximum column width.

Important Information and Disclaimer: The information provided on this page represents TI's knowledge and belief as of the date that it is provided. TI bases its knowledge and belief on information provided by third parties, and makes no representation or warranty as to the accuracy of such information. Efforts are underway to better integrate information from third parties. TI has taken and continues to take reasonable steps to provide representative and accurate information but may not have conducted destructive testing or chemical analysis on incoming materials and chemicals. TI and TI suppliers consider certain information to be proprietary, and thus CAS numbers and other limited information may not be available for release.

In no event shall TI's liability arising out of such information exceed the total purchase price of the TI part(s) at issue in this document sold by TI to Customer on an annual basis.

TAPE AND REEL INFORMATION

QUADRANT ASSIGNMENTS FOR PIN 1 ORIENTATION IN TAPE

*All dimensions are nominal

Device	Package Type	Package Drawing	Pins	SPQ	Reel Diameter (mm)	Reel Width W1 (mm)	A0 (mm)	B0 (mm)	K0 (mm)	P1 (mm)	W (mm)	Pin1 Quadrant
TPA3140D2PWPR	HTSSOP	PWP	28	2000	330.0	16.4	6.9	10.2	1.8	12.0	16.0	Q1

TAPE AND REEL BOX DIMENSIONS



*All dimensions are nominal

Device	Package Type	Package Drawing	Pins	SPQ	Length (mm)	Width (mm)	Height (mm)
TPA3140D2PWPR	HTSSOP	PWP	28	2000	367.0	367.0	38.0

MECHANICAL DATA

PWP (R-PDSO-G28)

PowerPAD™ PLASTIC SMALL OUTLINE



- NOTES:
- All linear dimensions are in millimeters.
 - This drawing is subject to change without notice.
 - Body dimensions do not include mold flash or protrusions. Mold flash and protrusion shall not exceed 0.15 per side.
 - This package is designed to be soldered to a thermal pad on the board. Refer to Technical Brief, PowerPad Thermally Enhanced Package, Texas Instruments Literature No. SLMA002 for information regarding recommended board layout. This document is available at www.ti.com <<http://www.ti.com>>.
 - See the additional figure in the Product Data Sheet for details regarding the exposed thermal pad features and dimensions.
 - Falls within JEDEC MO-153

PowerPAD is a trademark of Texas Instruments.

THERMAL PAD MECHANICAL DATA

PWP (R-PDSO-G28) PowerPAD™ SMALL PLASTIC OUTLINE

THERMAL INFORMATION

This PowerPAD™ package incorporates an exposed thermal pad that is designed to be attached to a printed circuit board (PCB). The thermal pad must be soldered directly to the PCB. After soldering, the PCB can be used as a heatsink. In addition, through the use of thermal vias, the thermal pad can be attached directly to the appropriate copper plane shown in the electrical schematic for the device, or alternatively, can be attached to a special heatsink structure designed into the PCB. This design optimizes the heat transfer from the integrated circuit (IC).

For additional information on the PowerPAD package and how to take advantage of its heat dissipating abilities, refer to Technical Brief, PowerPAD Thermally Enhanced Package, Texas Instruments Literature No. SLMA002 and Application Brief, PowerPAD Made Easy, Texas Instruments Literature No. SLMA004. Both documents are available at www.ti.com.

The exposed thermal pad dimensions for this package are shown in the following illustration.



Top View

Exposed Thermal Pad Dimensions

4206332-33/AO 01/16

NOTE: A. All linear dimensions are in millimeters
 $\triangle B$. Exposed tie strap features may not be present.

PowerPAD is a trademark of Texas Instruments

PWP (R-PDSO-G28)

PowerPAD™ PLASTIC SMALL OUTLINE



- NOTES:
- A. All linear dimensions are in millimeters.
 - B. This drawing is subject to change without notice.
 - C. Customers should place a note on the circuit board fabrication drawing not to alter the center solder mask defined pad.
 - D. This package is designed to be soldered to a thermal pad on the board. Refer to Technical Brief, PowerPad Thermally Enhanced Package, Texas Instruments Literature No. SLMA002, SLMA004, and also the Product Data Sheets.
 - E. For specific thermal information, via requirements, and recommended board layout. These documents are available at www.ti.com <<http://www.ti.com>>. Publication IPC-7351 is recommended for alternate designs. Laser cutting apertures with trapezoidal walls and also rounding corners will offer better paste release. Customers should contact their board assembly site for stencil design recommendations. Example stencil design based on a 50% volumetric metal load solder paste. Refer to IPC-7525 for other stencil
 - F. Customers should contact their board fabrication site for solder mask tolerances between and around signal pads.

IMPORTANT NOTICE

Texas Instruments Incorporated and its subsidiaries (TI) reserve the right to make corrections, enhancements, improvements and other changes to its semiconductor products and services per JESD46, latest issue, and to discontinue any product or service per JESD48, latest issue. Buyers should obtain the latest relevant information before placing orders and should verify that such information is current and complete. All semiconductor products (also referred to herein as "components") are sold subject to TI's terms and conditions of sale supplied at the time of order acknowledgment.

TI warrants performance of its components to the specifications applicable at the time of sale, in accordance with the warranty in TI's terms and conditions of sale of semiconductor products. Testing and other quality control techniques are used to the extent TI deems necessary to support this warranty. Except where mandated by applicable law, testing of all parameters of each component is not necessarily performed.

TI assumes no liability for applications assistance or the design of Buyers' products. Buyers are responsible for their products and applications using TI components. To minimize the risks associated with Buyers' products and applications, Buyers should provide adequate design and operating safeguards.

TI does not warrant or represent that any license, either express or implied, is granted under any patent right, copyright, mask work right, or other intellectual property right relating to any combination, machine, or process in which TI components or services are used. Information published by TI regarding third-party products or services does not constitute a license to use such products or services or a warranty or endorsement thereof. Use of such information may require a license from a third party under the patents or other intellectual property of the third party, or a license from TI under the patents or other intellectual property of TI.

Reproduction of significant portions of TI information in TI data books or data sheets is permissible only if reproduction is without alteration and is accompanied by all associated warranties, conditions, limitations, and notices. TI is not responsible or liable for such altered documentation. Information of third parties may be subject to additional restrictions.

Resale of TI components or services with statements different from or beyond the parameters stated by TI for that component or service voids all express and any implied warranties for the associated TI component or service and is an unfair and deceptive business practice. TI is not responsible or liable for any such statements.

Buyer acknowledges and agrees that it is solely responsible for compliance with all legal, regulatory and safety-related requirements concerning its products, and any use of TI components in its applications, notwithstanding any applications-related information or support that may be provided by TI. Buyer represents and agrees that it has all the necessary expertise to create and implement safeguards which anticipate dangerous consequences of failures, monitor failures and their consequences, lessen the likelihood of failures that might cause harm and take appropriate remedial actions. Buyer will fully indemnify TI and its representatives against any damages arising out of the use of any TI components in safety-critical applications.

In some cases, TI components may be promoted specifically to facilitate safety-related applications. With such components, TI's goal is to help enable customers to design and create their own end-product solutions that meet applicable functional safety standards and requirements. Nonetheless, such components are subject to these terms.

No TI components are authorized for use in FDA Class III (or similar life-critical medical equipment) unless authorized officers of the parties have executed a special agreement specifically governing such use.

Only those TI components which TI has specifically designated as military grade or "enhanced plastic" are designed and intended for use in military/aerospace applications or environments. Buyer acknowledges and agrees that any military or aerospace use of TI components which have **not** been so designated is solely at the Buyer's risk, and that Buyer is solely responsible for compliance with all legal and regulatory requirements in connection with such use.

TI has specifically designated certain components as meeting ISO/TS16949 requirements, mainly for automotive use. In any case of use of non-designated products, TI will not be responsible for any failure to meet ISO/TS16949.

Products

Audio	www.ti.com/audio
Amplifiers	amplifier.ti.com
Data Converters	dataconverter.ti.com
DLP® Products	www.dlp.com
DSP	dsp.ti.com
Clocks and Timers	www.ti.com/clocks
Interface	interface.ti.com
Logic	logic.ti.com
Power Mgmt	power.ti.com
Microcontrollers	microcontroller.ti.com
RFID	www.ti-rfid.com
OMAP Applications Processors	www.ti.com/omap
Wireless Connectivity	www.ti.com/wirelessconnectivity

Applications

Automotive and Transportation	www.ti.com/automotive
Communications and Telecom	www.ti.com/communications
Computers and Peripherals	www.ti.com/computers
Consumer Electronics	www.ti.com/consumer-apps
Energy and Lighting	www.ti.com/energy
Industrial	www.ti.com/industrial
Medical	www.ti.com/medical
Security	www.ti.com/security
Space, Avionics and Defense	www.ti.com/space-avionics-defense
Video and Imaging	www.ti.com/video

TI E2E Community

e2e.ti.com