

FIBER OPTIC TRANSMITTING MODULE

TOTX147(F,T)

FIBER OPTIC TRANSMITTING MODULE FOR DIGITAL AUDIO EQUIPMENT

Unit: mm

- Conforms to JEITA Standard CP-1212 (Digital Audio Optical Interface for Consumer Equipment).
- LED is driven by differential circuit.
- A Self-tapping hole for easy attachment to Audio Equipment panels.
- RoHS Compatible

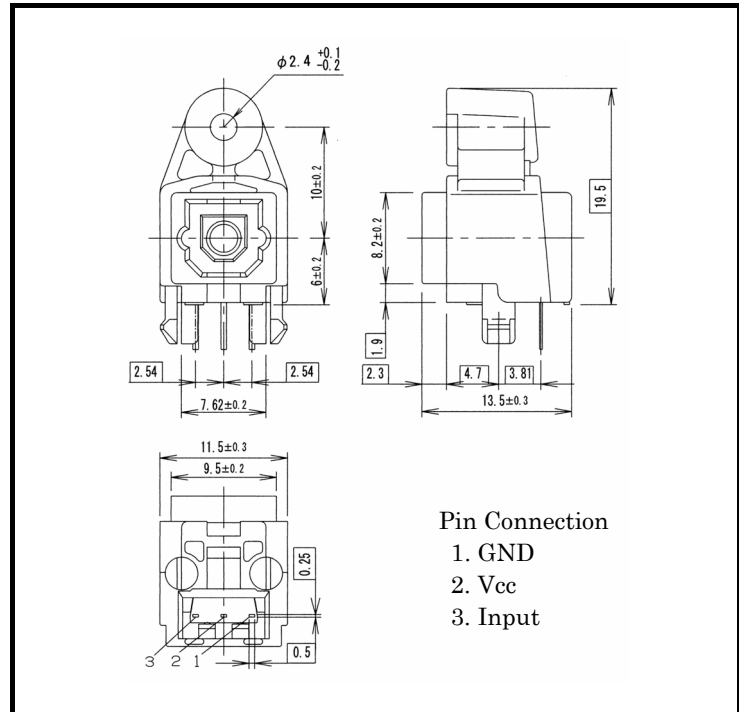

1. Absolute Maximum Ratings (Ta = 25°C)

Characteristics	Symbol	Rating	Unit
Storage Temperature	T _{stg}	-40 to 70	°C
Operating Temperature	T _{opr}	-20 to 70	°C
Supply Voltage	V _{CC}	-0.5 to 4.5	V
Input Voltage	V _{IN}	-0.5 to V _{CC} + 0.5	V
Soldering Temperature	T _{sol}	260 (Note 1)	°C

Note 1: Soldering time ≤ 10 seconds (At a distance of 1 mm from the package).

2. Operating Range

Characteristics	Symbol	Min	Typ.	Max	Unit
Supply Voltage	V _{CC}	2.7	3.0	3.6	V
High-Level Input Voltage	V _{IH}	2.1	---	V _{CC}	V
Low-Level Input Voltage	V _{IL}	0	---	0.9	V

Handling precaution: The LED's used in this product contain GaAs (Gallium Arsenide). Care must be taken to protect the safety of people and the environment when scrapping or terminal processing.

3. Electrical and Optical Characteristics (Ta = 25°C, VCC = 3 V)

Characteristics	Symbol	Test Condition	Min	Typ.	Max	Unit
Data Rate		NRZ Code (Note 2)	DC	---	15	Mb / s
Transmission Distance		Using APF (Note 3) and TORX147(F,T)	0.2	---	5	m
Pulse Width Distortion (Note 4)	Δt_w	Pulse Width = 67 ns Pulse Cycle = 134 ns Using TORX147(F,T) CL = 10 pF	-15	---	15	ns
Fiber Output Power (Note 5)	Pf		-21	---	-15	dBm
Peak Emission Wavelength	λ_c		---	650	---	nm
Current Consumption	ICC		---	8	15	mA
High Level Input Voltage	V _{IH}		2.1	---	---	V
Low Level Input Voltage	V _{IL}		---	---	0.9	V

Note 2: LED is on when input signal is high, and off when it is low.
7.5Mb/s (max.) Biphase marked signal.

Note 3: All Plastic Fiber (980 / 1000 μm).

Note 4: Between input of TOTX147(F,T) and output of TORX147(F,T).

Note 5: Measure with a standard optical fiber, peak value.

4. Mechanical Characteristics (Ta = 25°C)

Characteristics	Symbol	Test Condition	Min	Typ.	Max	Unit
Insertion Force (Note 6)		Initial value	---	---	39.2	N
Withdrawal Force (Note 6)		Initial value	5.9	---	39.2	N
Torque for Self-Tap		Using self-tapping screw (M3 × 8)	58.8	---	98	N·cm

Note 6: Square type connector : EIAJ RC-5720B

5. Application Circuit

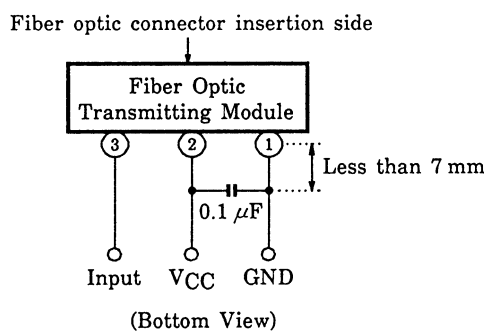

6. Required Optical Fiber with Fiber Optic Connectors

All Plastic Fiber with Square Type Connector (EIAJ RC-5720B)

7. Board layout hole pattern (Recommendation)

Unit: mm

Tolerance: ± 0.05 mm

Recommended PCB thickness: 1.6 mm

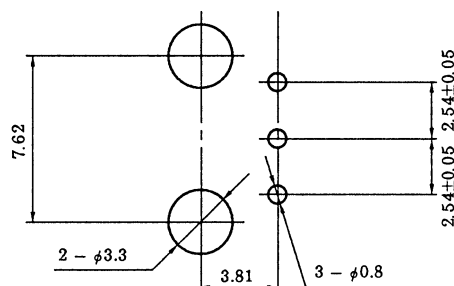

8. Precautions during use

(1) Absolute maximum rating

The absolute maximum ratings are the limit values which must not be exceeded during operation of device. None of these rating value must not be exceeded. If the absolute maximum rating value is exceeded, the characteristics of devices may never be restored properly. In extreme cases, the device may be permanently damages.

(2) Lifetime of light emitters

If an optical module is used for a long period of time, degeneration in the characteristics will mostly be due to a lowering of the fiber output power (Pf). This is caused by the degradation of the optical output of the LEDs used as the light source. The cause of degradation of the optical output of the LEDs may be defects in wafer crystallization or mold resin stress. The detailed causes are, however, not clear.

The lifetime of light emitters is greatly influenced by the operating conditions and the environment in which it is used as well as by the lifetime characteristics unique to the device type. Thus, when a light emitting device and its operating conditions determined, Toshiba recommend that lifetime characteristics be checked.

Depending on the environment conditions, Toshiba recommend that maintenance such as regular checks of the amount of optical output in accordance with the condition of operating environment.

(3) Soldering

Optical modules are comprised of internal semiconductor devices. However, in principle, optical modules are optical components. During soldering, ensure that flux does not contact with the emitting surface or the detecting surface. Also ensure that proper flux removal is conducted after soldering. Some optical modules come with a protective cap. The protective cap is used to avoid malfunction when the optical module is not in use. Note that it is not dust or waterproof.

As mentioned before, optical modules are optical components. Thus, in principle, soldering where there may be flux residue and flux removal after soldering is not recommended. Toshiba recommend that soldering be performed without the optical module mounted on the board. Then, after the board has been cleaned, the optical module should be soldered on to the board manually.

If the optical module cannot be soldered manually, use non-halogen (chlorine-free) flux and make sure, without cleaning, there is no residue such as chlorine. This is one of the ways to eliminate the effects of flux. In such a cases, be sure to check the devices' reliability.

(4) Vibration and shock

This module is plastic sealed and has its wire fixed by resin. This structure is relatively resistant to vibration and shock. In actual equipment, there are sometimes cases in which vibration, shock, or stress is applied to soldered parts or connected parts, resulting in lines cut. A care must be taken in the design of equipment which will be subject to high levels of vibration.

(5) Support pins

The optical transmission module TOTX147(F,T) has support pins in order to fix itself to the PCB temporary. Please make the hole for these pins in the PCB under the condition described in board layout hole pattern.

- (6) Panel attachment
TOTX147(F,T) has hole for panel attachment. Please be sure to attach it to panel with self-tapping screw.
- (7) Solvent
When using solvent for flux removal, do not use a high acid or high alkali solvent. Be careful not to pour solvent in to the optical connector ports. If solvent is inadvertently poured in to them, clean it off using cotton tips.
- (8) Protective cap
When the TOTX147(F,T) is not in use, attach the protective cap.
- (9) Supply voltage
Use the supply voltage within the recommended operating condition ($V_{CC} = 2.7$ to $3.6V$). Make sure that supply voltage does not exceed the maximum rating value of $4.5 V$, even for an instant.
- (10) Input voltage
If a voltage exceeding the maximum rating value ($V_{CC} + 0.5 V$) is applied to the transmitters' input, the internal IC may suffer damage. If there is a possibility that excessive voltage due to surges may be added to the input terminal, insert a protective circuit.
- (11) Soldering condition
Solder at $260^{\circ}C$ or less for no more than ten seconds.
- (12) Precautions when disposing of devices and packing materials.
When disposing devices and packing materials, follow the procedures stipulated by local regulations in order to protect the environment against contamination.
Compound semiconductors such, as GaAs are used as LED materials in this module. When devices are disposed of, worker safety and protection of the environment must be taken into account.
- (13) Precautions during use
Toshiba is continually working to improve the quality and reliability of their products. Nevertheless, semiconductor devices in general can malfunction or fail due to their inherent electrical sensitivity and their vulnerability to physical stress. It is the responsibility of the buyer, when utilizing Toshiba products, to observe standards of safety, and to avoid situations in which the malfunction or failure of a Toshiba product could cause loss of human life, bodily injury or damage to property.
When developing equipment, please ensure that Toshiba products are used within the specified operating ranges set forth in the most recent product specifications. Also, please keep in mind the precautions and conditions set forth in the Toshiba Semiconductor Reliability Handbook.

RESTRICTIONS ON PRODUCT USE

20070701-EN

- The information contained herein is subject to change without notice.
- TOSHIBA is continually working to improve the quality and reliability of its products. Nevertheless, semiconductor devices in general can malfunction or fail due to their inherent electrical sensitivity and vulnerability to physical stress. It is the responsibility of the buyer, when utilizing TOSHIBA products, to comply with the standards of safety in making a safe design for the entire system, and to avoid situations in which a malfunction or failure of such TOSHIBA products could cause loss of human life, bodily injury or damage to property.
In developing your designs, please ensure that TOSHIBA products are used within specified operating ranges as set forth in the most recent TOSHIBA products specifications. Also, please keep in mind the precautions and conditions set forth in the "Handling Guide for Semiconductor Devices," or "TOSHIBA Semiconductor Reliability Handbook" etc.
- The TOSHIBA products listed in this document are intended for usage in general electronics applications (computer, personal equipment, office equipment, measuring equipment, industrial robotics, domestic appliances, etc.). These TOSHIBA products are neither intended nor warranted for usage in equipment that requires extraordinarily high quality and/or reliability or a malfunction or failure of which may cause loss of human life or bodily injury ("Unintended Usage"). Unintended Usage include atomic energy control instruments, airplane or spaceship instruments, transportation instruments, traffic signal instruments, combustion control instruments, medical instruments, all types of safety devices, etc.. Unintended Usage of TOSHIBA products listed in this document shall be made at the customer's own risk.
- The products described in this document shall not be used or embedded to any downstream products of which manufacture, use and/or sale are prohibited under any applicable laws and regulations.
- The information contained herein is presented only as a guide for the applications of our products. No responsibility is assumed by TOSHIBA for any infringements of patents or other rights of the third parties which may result from its use. No license is granted by implication or otherwise under any patents or other rights of TOSHIBA or the third parties.
- GaAs(Gallium Arsenide) is used in this product. The dust or vapor is harmful to the human body. Do not break, cut, crush or dissolve chemically.
- Please contact your sales representative for product-by-product details in this document regarding RoHS compatibility. Please use these products in this document in compliance with all applicable laws and regulations that regulate the inclusion or use of controlled substances. Toshiba assumes no liability for damage or losses occurring as a result of noncompliance with applicable laws and regulations.