

## CMOS 8-Bit Microcontroller

## TMP87PH48U/DF, TMP87PM48U/DF

The TMP87PH48 is a one-time PROM microcontroller with low-power 128 Kbits (16 Kbytes) electrically programmable read only memory for the TMP87CH48 system evaluation. The TMP87PM48 is a One-time PROM microcontroller with low-power 256 Kbits (32 Kbytes) electrically programmable read only memory for the TMP87CM48 system evaluation. The TMP87PH48/PM48 are pin compatible with the TMP87CH48/CM48. The operations possible with the TMP87CH48/CM48 can be performed by writing programs to PROM. The TMP87PH48/PM48 can write and verify in the same way as the TC57256AD using an adaptor sockets BM11117/BM11147 and an EPROM programmer.

Product No.	ROM	RAM	Package	Adapter Socket
TMP87PH48U	16 K × 8 bits	512 × 8 bits	P-LQFP64-1010-0.50	BM11117
TMP87PH48DF			P-QFP64-1414-0.80A	BM11147
TMP87PM48U	32 K × 8 bits	1 K × 8 bits	P-LQFP64-1010-0.50	BM11117
TMP87PM48DF			P-QFP64-1414-0.80A	BM11147

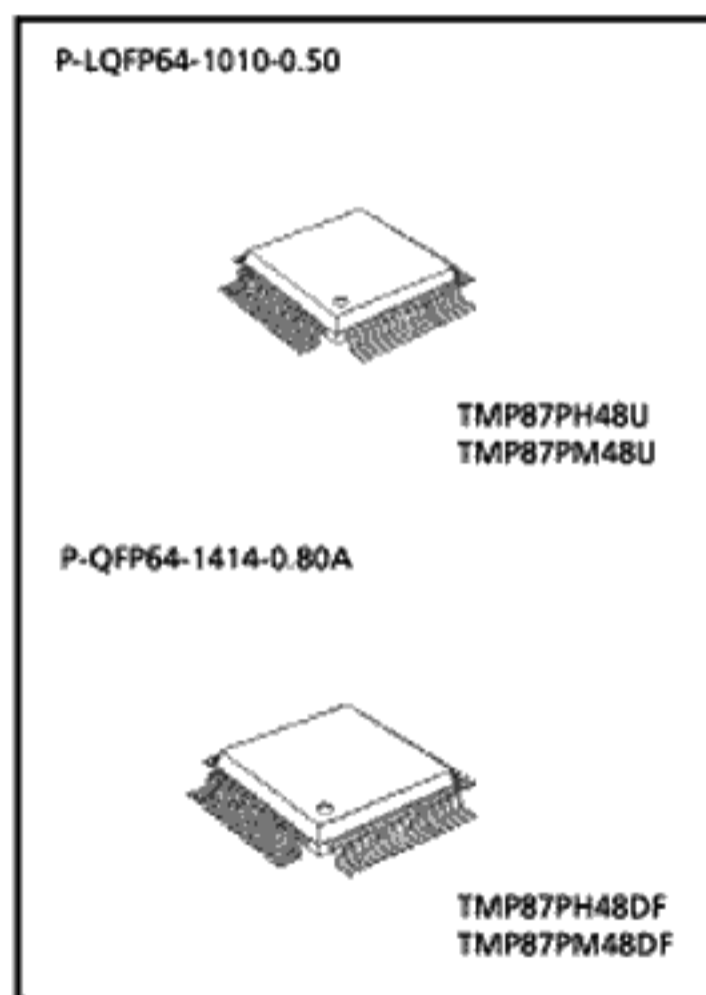

030619EP2

- The information contained herein is subject to change without notice.
- The information contained herein is presented only as a guide for the applications of our products. No responsibility is assumed by TOSHIBA for any infringements of patents or other rights of the third parties which may result from its use. No license is granted by implication or otherwise under any patent or patent rights of TOSHIBA or others.
- TOSHIBA is continually working to improve the quality and reliability of its products. Nevertheless, semiconductor devices in general can malfunction or fail due to their inherent electrical sensitivity and vulnerability to physical stress. It is the responsibility of the buyer, when utilizing TOSHIBA products, to comply with the standards of safety in making a safe design for the entire system, and to avoid situations in which a malfunction or failure of such TOSHIBA products could cause loss of human life, bodily injury or damage to property. In developing your designs, please ensure that TOSHIBA products are used within specified operating ranges as set forth in the most recent TOSHIBA products specifications. Also, please keep in mind the precautions and conditions set forth in the "Handling Guide for Semiconductor Devices," or "TOSHIBA Semiconductor Reliability Handbook" etc..
- The TOSHIBA products listed in this document are intended for usage in general electronics applications (computer, personal equipment, office equipment, measuring equipment, industrial robotics, domestic appliances, etc.). These TOSHIBA products are neither intended nor warranted for usage in equipment that requires extraordinarily high quality and/or reliability or a malfunction or failure of which may cause loss of human life or bodily injury ("Unintended Usage"). Unintended Usage include atomic energy control instruments, airplane or spaceship instruments, transportation instruments, traffic signal instruments, combustion control instruments, medical instruments, all types of safety devices, etc.. Unintended Usage of TOSHIBA products listed in this document shall be made at the customer's own risk.
- The products described in this document are subject to the foreign exchange and foreign trade laws.
- TOSHIBA products should not be embedded to the downstream products which are prohibited to be produced and sold, under any law and regulations.
- For a discussion of how the reliability of microcontrollers can be predicted, please refer to Section 1.3 of the chapter entitled Quality and Reliability Assurance/Handling Precautions.

Pin Assignments (Top View)

P-LQFP64-1010-0.50  
 P-QFP64-1414-0.80A

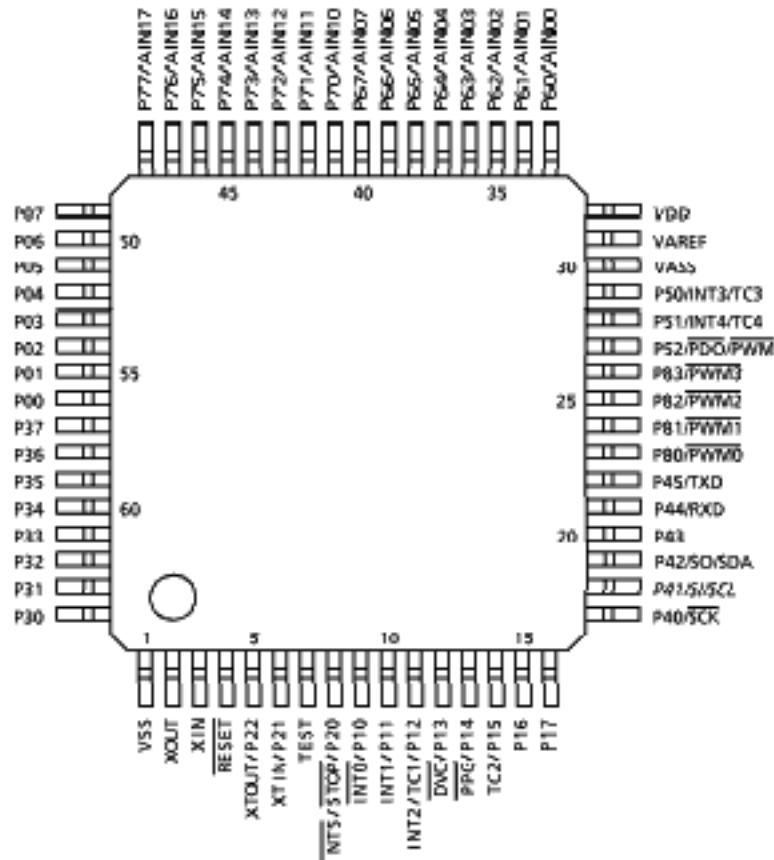

### Pin Function

The TMP87PH48/PM48 have two modes: MCU and PROM.

(1) MCU mode

In this mode, the TMP87PH48/PM48 are pin compatible with the TMP87CH48/CM48 (Fix the TEST pin at low level).

(2) PROM mode

Pin Name (PROM mode)	Input/Output	Functions	Pin Name (MCU mode)
A14 to A8	Input	PROM address inputs	P76 to P70
A7 to A0			P81, P80, P45 to P40
D7 to D0	I/O	PROM data input/outputs	P07 to P00
$\overline{CE}$	Input	Chip enable signal input (active low)	P13
$\overline{OE}$		Output enable signal input (active low)	P14
VPP	Power supply	+ 12.5 V/5 V (Program supply voltage)	TEST
VCC		+ 5 V	VDD
GND		0 V	VSS
P37 to P34	I/O	Open	
P32 to P30			
P52 to P50			
P83, P82			
P67 to P60			
P11, P12, P15	I/O	PROM mode setting pins. Be fixed at high level. (Pull-up with resistance R2)	
P21			
P77			
P17, P16, P10			
P133			
P22, P20			
RESET			
XIN	Input	Connect an 8 MHz oscillator to stabilize the internal state.	
XOUT	Output		
VAREF	Power Supply	0 V (GND)	
VASS			

## Operational Description

The following explains the TMP87PH48/PM48 hardware configuration and operation. The configuration and functions of the TMP87PH48/PM48 are the same as those of the TMP87CH48/CM48, except in that a one-time PROM is used instead of an on-chip mask ROM.

The TMP87PH48/PM48 are placed in the *single-clock* mode during reset. To use the dual-clock mode, the low-frequency oscillator should be turned on by executing [SET (SYSCR2). XTEN] instruction at the beginning of the program.

### 1. Operating Mode

The TMP87PH48/PM48 have two modes: MCU and PROM.

#### 1.1 MCU Mode

The MCU mode is activated by fixing the TEST/VPP pin at low level.

In the MCU mode, operation is the same as with the TMP87CH48/CM48 (The TEST/VPP pin cannot be used open because TMP87PH48/PM48 have no built-in pull-down resistance).

##### 1.1.1 Program Memory

The TMP87PH48/PM48 have a 16K × 8-bit (Addresses C000<sub>H</sub> to FFFF<sub>H</sub> in the MCU mode, addresses 4000<sub>H</sub> to 7FFF<sub>H</sub> in the PROM mode) the TMP87PM48 has a 32K × 8 bit (Address 8000<sub>H</sub> to FFFF<sub>H</sub> in the MCU mode, addresses 0000<sub>H</sub> to 7FFF<sub>H</sub> in the PROM mode) of program memory (OTP).

To use the TMP87PH48/PM48 as the system evaluation for the TMP87CH48/CM48, the program should be written to the program memory area as shown in Figure 1-1.

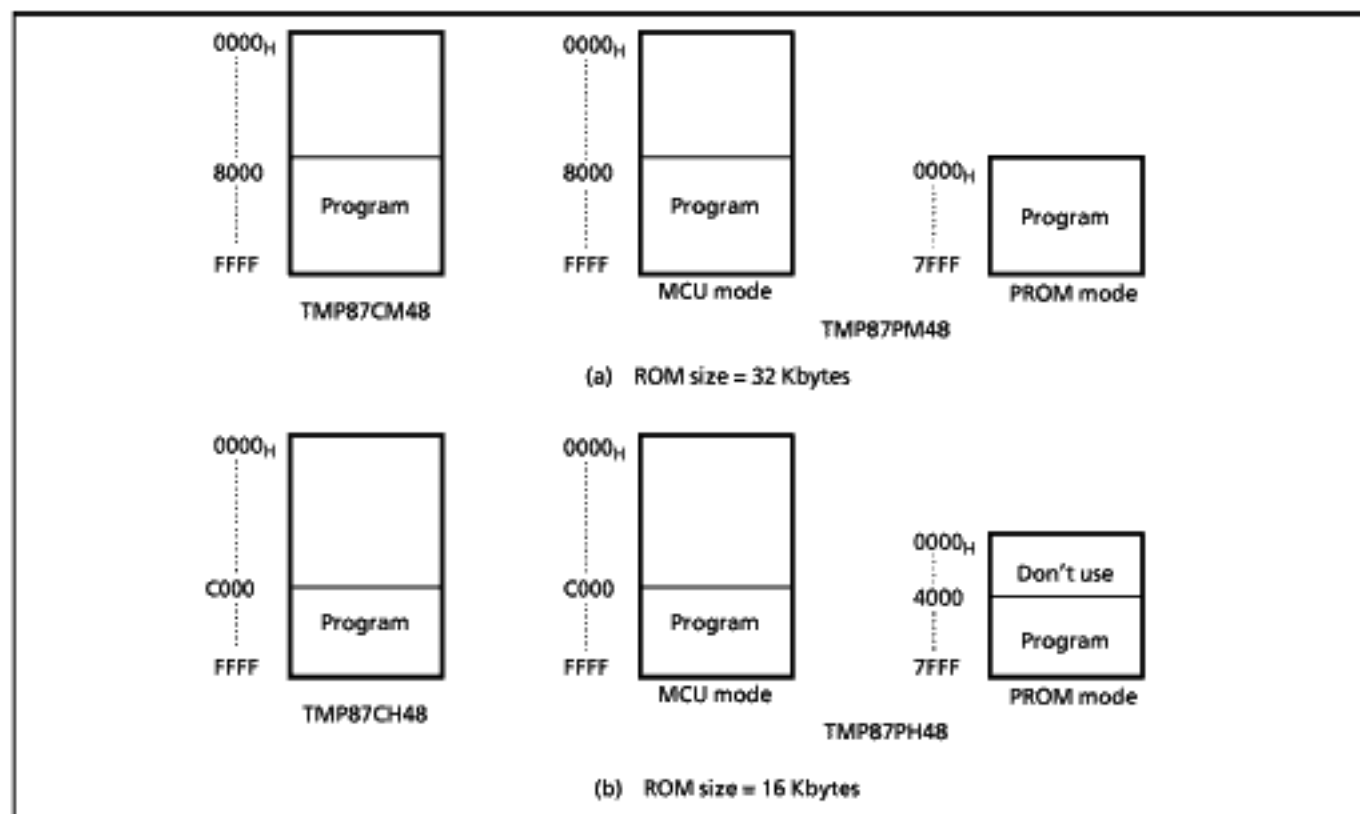

Figure 1-1. Program Memory Area

*Note: Either write the data FF<sub>H</sub> to the unused area or set the PROM programmer to access only the program storage area.*

## Electrical Characteristics

## (1) TMP87PH48

## Absolute Maximum Ratings

(V<sub>SS</sub> = 0 V)

Parameter	Symbol	Conditions	Ratings	Unit
Supply voltage	V <sub>DD</sub>		- 0.3 to 6.5	V
Input voltage	V <sub>IN</sub>		- 0.3 to V <sub>DD</sub> + 0.3	V
Output voltage	V <sub>OUT</sub>		- 0.3 to V <sub>DD</sub> + 0.3	V
Output current (Per 1 pin)	I <sub>OUT1</sub>	Ports P0, P1, P2, P4, P5, P6, P7, P8	3.2	mA
	I <sub>OUT2</sub>	Port P3	30	
Output current (Total)	Σ I <sub>OUT1</sub>	Ports P0, P1, P2, P4, P5, P6, P7, P8	120	mA
	Σ I <sub>OUT2</sub>	Port P3	120	
Power dissipation	PD		350	mW
Soldering temperature (Time)	T <sub>sld</sub>		260 (10 s)	°C
Storage temperature	T <sub>stg</sub>		- 55 to 125	°C
Operating temperature	T <sub>opr</sub>		- 40 to 85	°C

Note: The absolute maximum ratings are rated values which must not be exceeded during operation, even for an instant. Any one of the ratings must not be exceeded. If any absolute maximum rating is exceeded, a device may break down or its performance may be degraded, causing it to catch fire or explode resulting in injury to the user. Thus, when designing products which include this device, ensure that no absolute maximum rating value will ever be exceeded.

## Recommended Operating Conditions

(V<sub>SS</sub> = 0 V, T<sub>opr</sub> = - 40 to 85°C)

Parameter	Symbol	Pins	Conditions	Min	Max	Unit
Supply voltage	V <sub>DD</sub>		fc = 8 MHz	NORMAL 1/2 modes	4.5	V
				IDLE 1/2 modes		
			fc = 4.2 MHz	NORMAL 1/2 modes	2.7	
				IDLE 1/2 modes		
			fs = 32.768 kHz	SLOW mode	2.0	
	SLEEP mode					
Input high voltage	V <sub>IH1</sub>	Except hysteresis input	V <sub>DD</sub> ≥ 4.5 V	V <sub>DD</sub> × 0.70	V <sub>DD</sub>	V
	V <sub>IH2</sub>	Hysteresis input		V <sub>DD</sub> × 0.75		
	V <sub>IH3</sub>		V <sub>DD</sub> < 4.5 V	V <sub>DD</sub> × 0.90		
Input low voltage	V <sub>IL1</sub>	Except hysteresis input	V <sub>DD</sub> ≥ 4.5 V	0	V <sub>DD</sub> × 0.30	V
	V <sub>IL2</sub>	Hysteresis input			V <sub>DD</sub> × 0.25	
	V <sub>IL3</sub>		V <sub>DD</sub> < 4.5 V	V <sub>DD</sub> × 0.10		
Clock frequency	fc	XIN, XOUT	V <sub>DD</sub> = 4.5 to 5.5 V	0.4	8.0	MHz
			V <sub>DD</sub> = 2.7 to 5.5 V		4.2	
	fs	XTIN, XTOUT		30.0	34.0	kHz

Note 1: The recommended operating conditions for a device are operating conditions under which it can be guaranteed that the device will operate as specified. If the device is used under operating conditions other than the recommended operating conditions (Supply voltage, operating temperature range, specified AC/DC values etc.), malfunction may occur. Thus, when designing products which include this device, ensure that the recommended operating conditions for the device are always adhered to.

Note 2: The condition of clock frequency is in NORMAL 1/2 modes and IDLE 1/2 modes.

## DC Characteristics

(V<sub>SS</sub> = 0 V, T<sub>opr</sub> = -40 to 85°C)

Parameter	Symbol	Pins	Conditions	Min	Typ.	Max	Unit
Hysteresis voltage	V <sub>H5</sub>	Hysteresis inputs	V <sub>DD</sub> = 5.0 V	-	0.9	-	V
Input current	I <sub>IN1</sub>	TEST	V <sub>DD</sub> = 5.5 V V <sub>IN</sub> = 5.5 V/0 V	-	-	± 2	μA
	I <sub>IN2</sub>	Open drain ports, Tri-state ports					
	I <sub>IN3</sub>	RESET, STOP					
Input resistance	R <sub>IN2</sub>	RESET	V <sub>DD</sub> = 5.0 V	100	220	450	kΩ
Output leakage current	I <sub>LO</sub>	Sink open drain ports	V <sub>DD</sub> = 5.5 V, V <sub>OUT</sub> = 5.5 V	-	-	2	μA
		Tri-state ports	V <sub>DD</sub> = 5.5 V, V <sub>OUT</sub> = 5.5/0 V	-	-	± 2	
Output high voltage	V <sub>OH2</sub>	Tri-state ports	V <sub>DD</sub> = 4.5 V, I <sub>OH</sub> = -0.7 mA	4.1	-	-	V
Output low voltage	V <sub>OL</sub>	Except for XOUT and P3	V <sub>DD</sub> = 4.5 V, I <sub>OL</sub> = 1.6 mA	-	-	0.4	mA
Output low current	I <sub>OL3</sub>	P3	V <sub>DD</sub> = 4.5 V, V <sub>OL</sub> = 1.0 V	-	20	-	mA
Supply current in NORMAL 1, 2 modes	I <sub>DD</sub>		V <sub>DD</sub> = 5.5 V V <sub>IN</sub> = 5.3 V/0.2 V f <sub>c</sub> = 8 MHz f <sub>s</sub> = 32.768 kHz	-	4.5	5.5	mA
Supply current in IDLE 1, 2 modes				-	2.5	4.0	mA
Supply current in NORMAL 1, 2 modes			V <sub>DD</sub> = 3.0 V, V <sub>IN</sub> = 2.8 V/0.2 V V <sub>IN</sub> = 4.19 MHz f <sub>s</sub> = 32.768 kHz	-	1.75	3.0	mA
Supply current in IDLE 1, 2 modes				-	1.25	2.0	mA
Supply current in SLOW mode			V <sub>DD</sub> = 3.0 V V <sub>IN</sub> = 2.8 V/0.2 V f <sub>s</sub> = 32.768 kHz	-	20	30	μA
Supply current in SLEEP mode			V <sub>DD</sub> = 3.0 V V <sub>IN</sub> = 2.8 V/0.2 V f <sub>s</sub> = 32.768 kHz	-	10	20	μA
Supply current in STOP mode			V <sub>DD</sub> = 5.5 V V <sub>IN</sub> = 5.3 V/0.2 V	-	0.5	10	μA

Note 1: Typical values show those at T<sub>opr</sub> = 25°CNote 2: Input Current I<sub>IN1</sub>, I<sub>IN3</sub>: The current through resistor is not included, when the input resistor (pull-up or pull-down) is contained.Note 3: I<sub>DD</sub> except for I<sub>REF</sub>.

## AD Conversion Characteristics

(V<sub>SS</sub> = 0 V, V<sub>DD</sub> = 2.7 to 5.5 V, T<sub>opr</sub> = -40 to 85°C)

Parameter	Symbol	Conditions	Min	Typ.	Max			Unit
					ADCDR1	ADCDR2 ACK = 0   ACK = 1		
Analog reference voltage	V <sub>AREF</sub>	V <sub>AREF</sub> - V <sub>ASS</sub> ≥ 2.5 V	2.7	-	V <sub>DD</sub>			V
	V <sub>ASS</sub>		V <sub>SS</sub>	-	1.5			
Analog input voltage	V <sub>AIN</sub>		V <sub>ASS</sub>	-	V <sub>AREF</sub>			V
Analog supply current	I <sub>REF</sub>	V <sub>AREF</sub> = 5.5 V, V <sub>ASS</sub> = 0.0 V	-	0.5	1.2			mA
Nonlinearity error		V <sub>DD</sub> = 5.0, V <sub>SS</sub> = 0.0 V V <sub>AREF</sub> = 5.000 V V <sub>ASS</sub> = 0.000 V	-	-	± 1	± 3	± 2	LSB
Zero point error		V <sub>DD</sub> = 5.0, V <sub>SS</sub> = 0.0 V V <sub>AREF</sub> = 5.000 V V <sub>ASS</sub> = 0.000 V	-	-	± 1	± 3	± 2	
Full scale error		V <sub>DD</sub> = 2.7, V <sub>SS</sub> = 0.0 V V <sub>AREF</sub> = 2.700 V V <sub>ASS</sub> = 0.000 V	-	-	± 1	± 3	± 2	
Total error		V <sub>DD</sub> = 2.7, V <sub>SS</sub> = 0.0 V V <sub>AREF</sub> = 2.700 V V <sub>ASS</sub> = 0.000 V	-	-	± 2	± 6	± 4	

Note 1: ΔV<sub>AREF</sub> = V<sub>AREF</sub> - V<sub>ASS</sub>ADCDR1: 8 bits - AD conversion result (1LSB = ΔV<sub>AREF</sub>/256)ADCDR2: 10 bits - AD conversion result (1LSB = ΔV<sub>AREF</sub>/1024)

Note 2: Quantizing error is not contained in those errors.

AD Input Characteristics (Topr = -40 to 85°C)

Parameter	Symbol	Conditions	Min	Typ.	Max	Unit
Input impedance (Resistance)	$R_{AIN}$	$V_{DD} = 5.0\text{ V}$ , Conversion time $23\ \mu\text{s}$ ( $f_c = 8\text{ MHz}$ )	-	5	-	k $\Omega$
		$V_{DD} = 2.7\text{ V}$ , Conversion time $43.8\ \mu\text{s}$ ( $f_c = 4.2\text{ MHz}$ )	-	20	-	
Input impedance (Capacity)	$C_{AIN}$	$V_{DD} = 5.0\text{ V}$ , Conversion time $23\ \mu\text{s}$ ( $f_c = 8\text{ MHz}$ )	-	7	-	pF
		$V_{DD} = 2.7\text{ V}$ , Conversion time $43.8\ \mu\text{s}$ ( $f_c = 4.2\text{ MHz}$ )	-	7	-	
Source impedance	Rext	$V_{DD} = 5.0\text{ V}$ , Conversion time $23\ \mu\text{s}$ ( $f_c = 8\text{ MHz}$ )	-	-	5	k $\Omega$
		$V_{DD} = 2.7\text{ V}$ , Conversion time $43.8\ \mu\text{s}$ ( $f_c = 4.2\text{ MHz}$ )	-	-	5	

Note: Input current (Output leak current) error (Max  $\pm 2\ \mu\text{A}$ ) and quantizing error (Max  $\pm 4\text{LSB}$ ) for AD are contained.

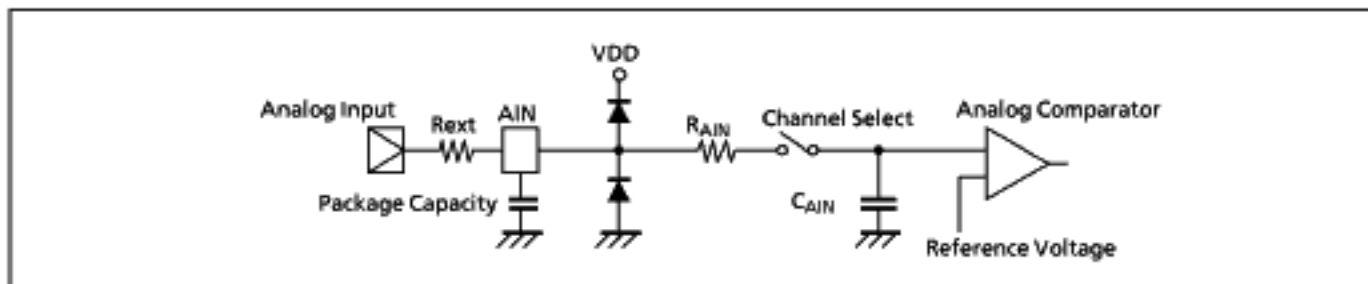

AD Pin Mode

AC Characteristics

(V<sub>SS</sub> = 0 V, T<sub>opr</sub> = -40 to 85°C)

Parameter	Symbol	Conditions	V <sub>DD</sub>	Min	Typ.	Max	Unit
Machine cycle time	t <sub>cy</sub>	In NORMAL 1, 2 mode	4.5 to 5.5 V	0.5	-	10	μs
		In IDLE 1, 2 mode					
		In SLOW mode	2.7 to 5.5 V	117.6	-	133.3	
		In SLEEP mode					
High level clock pulse width	t <sub>WCH</sub>	For external clock operation (XIN input), f <sub>c</sub> = 8 MHz	4.5 to 5.5 V	62.5	-	-	ns
Low level clock pulse width	t <sub>WCL</sub>						
High level clock pulse width	t <sub>WSH</sub>	For external clock operation (XTIN input), f <sub>s</sub> = 32.768 kHz	2.7 to 5.5 V	14.7	-	-	μs
Low level clock pulse width	t <sub>WSL</sub>						
AD conversion time	t <sub>ADC</sub>	ADCCR bit 4; ACK = 0	-	-	49 t <sub>cy</sub>	-	ns
		ADCCR bit 4; ACK = 1	-	-	196 t <sub>cy</sub>	-	

Timing of AD Conversion

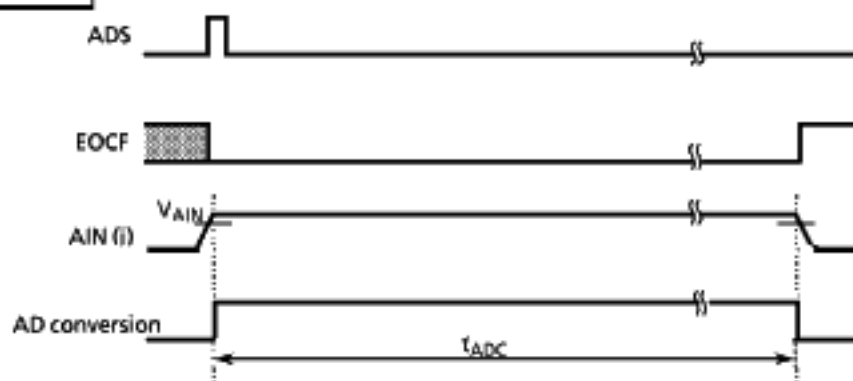

Note 1: During AD conversion, make the level of V<sub>AIN</sub> stable.  
 Note 2: i = 17 to 10, 07 to 00



Recommended Oscillating Conditions (V<sub>SS</sub> = 0 V, T<sub>opr</sub> = -40 to 85°C)

Parameter	Oscillator	Oscillation Frequency	VDD	Recommended Oscillator	Recommended Constant	
					C <sub>1</sub>	C <sub>2</sub>
High-frequency oscillation	Ceramic resonator	8 MHz	4.5 to 5.5 V	KYOCERA KBR8.0 M	30 pF	30 pF
		4 MHz	2.7 to 5.5 V	KYOCERA KBR4.0 MS MURATA CSA4.00 MG		
	Crystal oscillator	8 MHz	4.5 to 5.5 V	TOYOCOM 2108 8.0000	20 pF	20 pF
		4 MHz	2.7 to 5.5 V	TOYOCOM 2048 4.0000		
Low-frequency oscillation	Crystal oscillator	32.768 kHz	2.7 to 5.5 V	NDK MX-38T	15 pF	15 pF

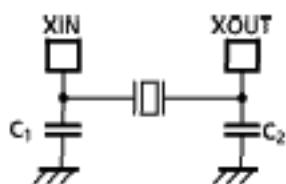

(1) High-frequency Oscillation

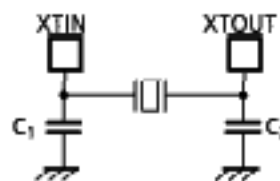

(2) Low-frequency Oscillation

**Note 1:** When it is used in high electrical field, an electrical shield of the package is recommended to retain normal operations.

**Note 2:** TOYAMA MURATA MFG. CO., LTD (JAPAN)

The product numbers and specifications of the resonators by Murata Manufacturing Co., Ltd. are subject to change.

For up-to-date information, please refer to the following URL;

<http://www.murata.co.jp/search/index.html>

**DC/AC Characteristics (PROM mode)** ( $V_{SS} = 0\text{ V}$ )

(1) Read operation

Parameter	Symbol	Conditions	Min	Typ.	Max	Unit
Input high voltage	$V_{IH4}$		2.2	–	$V_{CC}$	V
Input low voltage	$V_{IL4}$		0	–	0.8	V
Power supply voltage	$V_{CC}$		4.75	–	6.5	V
Program power supply voltage	$V_{PP}$					
Address access time	$t_{ACC}$	$V_{CC} = 5.0 \pm 0.25\text{ V}$	–	$1.5\text{ }t_{cyc} + 300$	–	ns

Note:  $t_{cyc} = 500\text{ ns}$  at 8 MHz

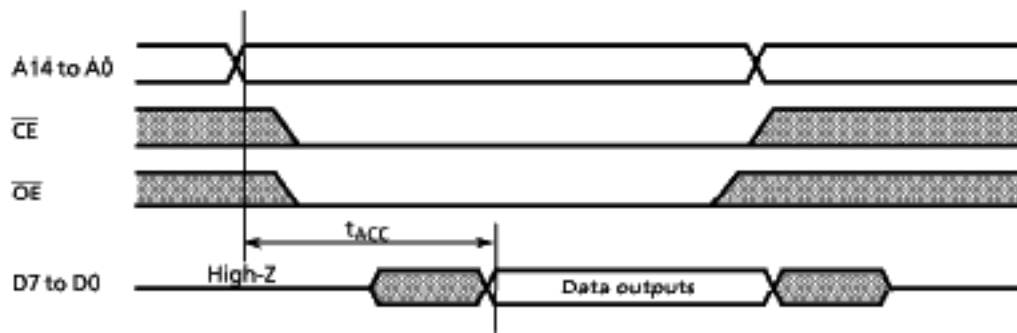

Timing Waveforms of Read Operation

(2) Program Operation (High-speed write mode - I) ( $T_{opr} = 25 \pm 5^{\circ}\text{C}$ )

Parameter	Symbol	Conditions	Min	Typ.	Max	Unit
Input high voltage	$V_{IH4}$		2.2	-	$V_{CC}$	V
Input low voltage	$V_{IL4}$		0	-	0.8	V
Power supply voltage	$V_{CC}$		5.75	-	6.5	V
Program power supply voltage	$V_{PP}$		12.0	12.5	13.0	V
Initial program pulse width	$t_{PW}$	$V_{CC} = 6.0\text{V} \pm 0.25\text{V}$ , $V_{PP} = 12.5\text{V} \pm 0.5\text{V}$	0.95	1.0	1.05	ms

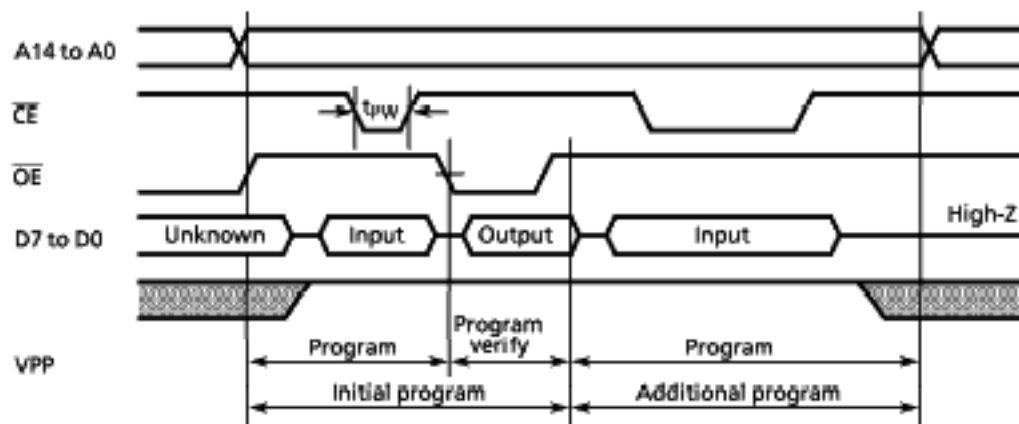

Timing Waveforms of Programming Operation

- Note 1:** When  $V_{CC}$  power supply is turned on or after,  $V_{PP}$  must be increased.  
When  $V_{CC}$  power supply is turned off or before,  $V_{PP}$  must be decreased.
- Note 2:** The device must not be set to the EPROM programmer or picked up from it under applying the program voltage ( $12.5\text{V} \pm 0.5\text{V}$ ) to the  $V_{PP}$  pin as the device is damaged.
- Note 3:** Be sure to execute the recommended programming mode with the recommended programming adaptor. If a mode or an adaptor except the above, the misoperation sometimes occurs.

(3) Program operation (High-speed write mode -II) ( $T_{opr} = 25 \pm 5^{\circ}\text{C}$ )

Parameter	Symbol	Conditions	Min	Typ.	Max	Unit
Input high voltage	$V_{IH4}$		2.2	-	$V_{CC}$	V
Input low voltage	$V_{IL4}$		0	-	0.8	V
Supply voltage	$V_{CC}$		6.00	6.25	6.50	V
Program supply voltage	$V_{PP}$		12.50	12.75	13.0	V
Initial program pulse width	$t_{PW}$	$V_{CC} = 6.25\text{ V} \pm 0.25\text{ V}$ , $V_{PP} = 12.75\text{ V} \pm 0.25\text{ V}$	0.095	0.1	0.105	ms

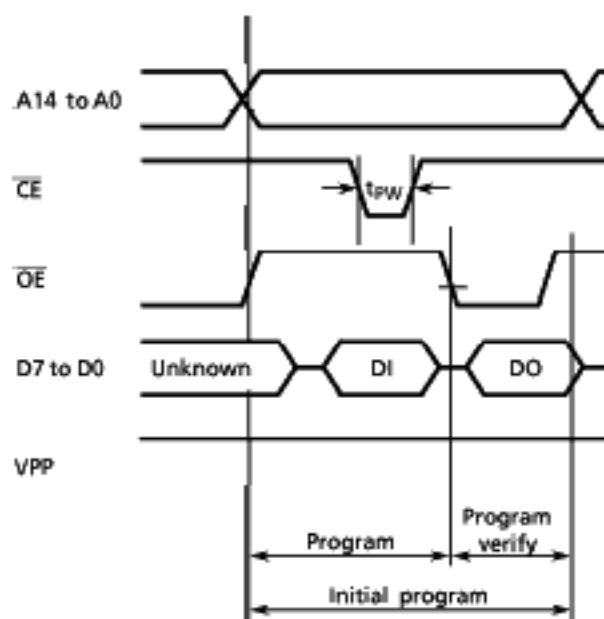

Note: DO: Data output (I0 to I7)  
DI: Data input (I0 to I7)

**Note 1:** When  $V_{CC}$  power supply is turned on or after,  $V_{PP}$  must be increased.

When  $V_{CC}$  power supply is turned off or before,  $V_{PP}$  must be decreased.

**Note 2:** The device must not be set to the EPROM programmer or picked up from it under applying the program voltage ( $12.75\text{ V} \pm 0.25\text{ V}$ ) to the  $V_{PP}$  pin as the device is damaged.

**Note 3:** Be sure to execute the recommended programming mode with the recommended programming adaptor. If a mode or an adaptor except the above, the misoperation sometimes occurs.

## Electrical Characteristics

(2) TMP87PM48

## Absolute Maximum Ratings

 $(V_{SS} = 0\text{ V})$ 

Parameter	Symbol	Conditions	Ratings	Unit
Supply voltage	$V_{DD}$		-0.3 to 6.5	V
Input voltage	$V_{IN}$		-0.3 to $V_{DD} + 0.3$	V
Output voltage	$V_{OUT}$		-0.3 to $V_{DD} + 0.3$	V
Output current (Per 1 pin)	$I_{OUT1}$	Ports P0, P1, P2, P4, P5, P6, P7, P8	3.2	mA
	$I_{OUT2}$	Port P3	30	
Output current (Total)	$\Sigma I_{OUT1}$	Ports P0, P1, P2, P4, P5, P6, P7, P8	120	mA
	$\Sigma I_{OUT2}$	Port P3	120	
Power dissipation	PD		350	mW
Soldering temperature (Time)	$T_{sld}$		260 (10 s)	$^{\circ}\text{C}$
Storage temperature	$T_{stg}$		-55 to 125	$^{\circ}\text{C}$
Operating temperature	$T_{opr}$		-40 to 85	$^{\circ}\text{C}$

Note: The absolute maximum ratings are rated values which must not be exceeded during operation, even for an instant. Any one of the ratings must not be exceeded. If any absolute maximum rating is exceeded, a device may break down or its performance may be degraded, causing it to catch fire or explode resulting in injury to the user. Thus, when designing products which include this device, ensure that no absolute maximum rating value will ever be exceeded.

## Recommended Operating Conditions

 $(V_{SS} = 0\text{ V}, T_{opr} = -40\text{ to }85^{\circ}\text{C})$ 

Parameter	Symbol	Pins	Conditions	Min	Max	Unit	
Supply voltage	$V_{DD}$		$f_c = 8\text{ MHz}$	NORMAL1/2 modes	4.5	5.5	V
				IDLE1/2 modes			
			$f_c = 4.2\text{ MHz}$	NORMAL1/2 modes	2.7		
				IDLE1/2 modes			
$f_s = 32.768\text{ kHz}$	SLOW mode	2.0					
	SLEEP mode						
Input high voltage	$V_{IH1}$	Except hysteresis input	$V_{DD} \geq 4.5\text{ V}$	$V_{DD} \times 0.70$	$V_{DD}$	V	
	$V_{IH2}$	Hysteresis input		$V_{DD} \times 0.75$			
	$V_{IH3}$		$V_{DD} < 4.5\text{ V}$	$V_{DD} \times 0.90$			
Input low voltage	$V_{IL1}$	Except hysteresis input	$V_{DD} \geq 4.5\text{ V}$	0	$V_{DD} \times 0.30$	V	
	$V_{IL2}$	Hysteresis input			$V_{DD} \times 0.25$		
	$V_{IL3}$		$V_{DD} < 4.5\text{ V}$		$V_{DD} \times 0.10$		
Clock frequency	$f_c$	XIN, XOUT	$V_{DD} = 4.5\text{ to }5.5\text{ V}$	0.4	8.0	MHz	
			$V_{DD} = 2.7\text{ to }5.5\text{ V}$		4.2		
	$f_s$	XTIN, XTOUT		30.0	34.0	kHz	

Note 1: The recommended operating conditions for a device are operating conditions under which it can be guaranteed that the device will operate as specified. If the device is used under operating conditions other than the recommended operating conditions (Supply voltage, operating temperature range, specified AC/DC values etc.), malfunction may occur. Thus, when designing products which include this device, ensure that the recommended operating conditions for the device are always adhered to.

Note 2: The condition of clock frequency is in NORMAL1/2 modes and IDLE1/2 modes.

## DC Characteristics

 $(V_{SS} = 0\text{ V}, T_{opr} = -40\text{ to }85^{\circ}\text{C})$ 

Parameter	Symbol	Pins	Conditions	Min	Typ.	Max	Unit
Hysteresis voltage	$V_{HS}$	Hysteresis inputs	$V_{DD} = 5.0\text{ V}$	–	0.9	–	V
Input current	$I_{IN1}$	TEST	$V_{DD} = 5.5\text{ V}$ $V_{IN} = 5.5\text{ V}/0\text{ V}$	–	–	$\pm 2$	$\mu\text{A}$
	$I_{IN2}$	Open drain ports, Tri-state ports					
	$I_{IN3}$	RESET, STOP					
Input resistance	$R_{IN2}$	RESET	$V_{DD} = 5.0\text{ V}$	100	220	450	$\text{k}\Omega$
Output leakage current	$I_{LO}$	Sink open drain ports	$V_{DD} = 5.5\text{ V}, V_{OUT} = 5.5\text{ V}$	–	–	2	$\mu\text{A}$
		Tri-state ports	$V_{DD} = 5.5\text{ V}, V_{OUT} = 5.5/0\text{ V}$	–	–	$\pm 2$	
Output high voltage	$V_{OH2}$	Tri-state ports	$V_{DD} = 4.5\text{ V}, I_{OH} = -0.7\text{ mA}$	4.1	–	–	V
Output low voltage	$V_{OL}$	Except for XOUT and P3	$V_{DD} = 4.5\text{ V}, I_{OL} = 1.6\text{ mA}$	–	–	0.4	mA
Output low current	$I_{OL3}$	P3	$V_{DD} = 4.5\text{ V}, V_{OL} = 1.0\text{ V}$	–	20	–	mA
Supply current in NORMAL 1, 2 modes	$I_{DD}$		$V_{DD} = 5.5\text{ V}$ $V_{IN} = 5.3\text{ V}/0.2\text{ V}$ $f_c = 8\text{ MHz}$ $f_s = 32.768\text{ kHz}$	–	4.75	6.4	mA
Supply current in IDLE 1, 2 modes				–	3.25	4.65	mA
Supply current in NORMAL 1, 2 modes			$V_{DD} = 3.0\text{ V}, V_{IN} = 2.8\text{ V}/0.2\text{ V}$ $V_{IN} = 4.19\text{ MHz}$ $f_s = 32.768\text{ kHz}$	–	1.87	3.2	mA
Supply current in IDLE 1, 2 modes				–	1.35	2.2	mA
Supply current in SLOW mode			$V_{DD} = 3.0\text{ V}$ $V_{IN} = 2.8\text{ V}/0.2\text{ V}$ $f_s = 32.768\text{ kHz}$	–	20	30	$\mu\text{A}$
Supply current in SLEEP mode			$V_{DD} = 3.0\text{ V}$ $V_{IN} = 2.8\text{ V}/0.2\text{ V}$ $f_s = 32.768\text{ kHz}$	–	10	20	$\mu\text{A}$
Supply current in STOP mode			$V_{DD} = 5.5\text{ V}$ $V_{IN} = 5.3\text{ V}/0.2\text{ V}$	–	0.5	10	$\mu\text{A}$

Note 1: Typical values show those at  $T_{opr} = 25^{\circ}\text{C}$ Note 2: Input Current  $I_{IN1}, I_{IN3}$ : The current through resistor is not included, when the input resistor (pull-up or pull-down) is contained.Note 3:  $I_{DD}$  except for  $I_{REF}$ .

## AD Conversion Characteristics

 $(V_{SS} = 0\text{ V}, V_{DD} = 2.7\text{ to }5.5\text{ V}, T_{opr} = -40\text{ to }85^{\circ}\text{C})$ 

Parameter	Symbol	Conditions	Min	Typ.	Max		Unit	
					ADCDR1	ADCDR2 ACK = 0   ACK = 1		
Analog reference voltage	$V_{AREF}$	$V_{AREF} - V_{ASS} \approx 2.5\text{ V}$	2.7	–	$V_{DD}$		V	
	$V_{ASS}$		$V_{SS}$	–	1.5			
Analog input voltage	$V_{AIN}$		$V_{ASS}$	–	$V_{AREF}$		V	
Analog supply current	$I_{REF}$	$V_{AREF} = 5.5\text{ V},$ $V_{ASS} = 0.0\text{ V}$	–	0.5	1.2		mA	
Nonlinearity error		$V_{DD} = 5.0, V_{SS} = 0.0\text{ V}$ $V_{AREF} = 5.000\text{ V}$ $V_{ASS} = 0.000\text{ V}$ or $V_{DD} = 2.7, V_{SS} = 0.0\text{ V}$ $V_{AREF} = 2.700\text{ V}$ $V_{ASS} = 0.000\text{ V}$	–	–	$\pm 1$	$\pm 3$	LSB	
Zero point error			–	–	$\pm 1$	$\pm 3$		$\pm 2$
Full scale error			–	–	$\pm 1$	$\pm 3$		$\pm 2$
Total error			–	–	$\pm 2$	$\pm 6$		$\pm 4$

Note 1:  $\Delta V_{AREF} = V_{AREF} - V_{ASS}$ ADCDR1: 8 bits – AD conversion result (1LSB =  $\Delta V_{AREF}/256$ )ADCDR2: 10 bits – AD conversion result (1LSB =  $\Delta V_{AREF}/1024$ )

Note 2: Quantizing error is not contained in those errors.

**AD Input Characteristics** (Topr = -40 to 85°C)

Parameter	Symbol	Conditions	Min	Typ.	Max	Unit
Input impedance (Resistance)	$R_{AIN}$	$V_{DD} = 5.0\text{ V}$ , Conversion time $23\ \mu\text{s}$ ( $f_c = 8\text{ MHz}$ )	-	5	-	$\text{k}\Omega$
		$V_{DD} = 2.7\text{ V}$ , Conversion time $43.8\ \mu\text{s}$ ( $f_c = 4.2\text{ MHz}$ )	-	20	-	
Input impedance (Capacity)	$C_{AIN}$	$V_{DD} = 5.0\text{ V}$ , Conversion time $23\ \mu\text{s}$ ( $f_c = 8\text{ MHz}$ )	-	7	-	$\text{pF}$
		$V_{DD} = 2.7\text{ V}$ , Conversion time $43.8\ \mu\text{s}$ ( $f_c = 4.2\text{ MHz}$ )	-	7	-	
Source impedance	$R_{ext}$	$V_{DD} = 5.0\text{ V}$ , Conversion time $23\ \mu\text{s}$ ( $f_c = 8\text{ MHz}$ )	-	-	5	$\text{k}\Omega$
		$V_{DD} = 2.7\text{ V}$ , Conversion time $43.8\ \mu\text{s}$ ( $f_c = 4.2\text{ MHz}$ )	-	-	5	

Note: Input current (Output leak current) error (Max  $\pm 2\ \mu\text{A}$ ) and quantizing error (Max  $\pm 4\text{LSB}$ ) for AD are contained.

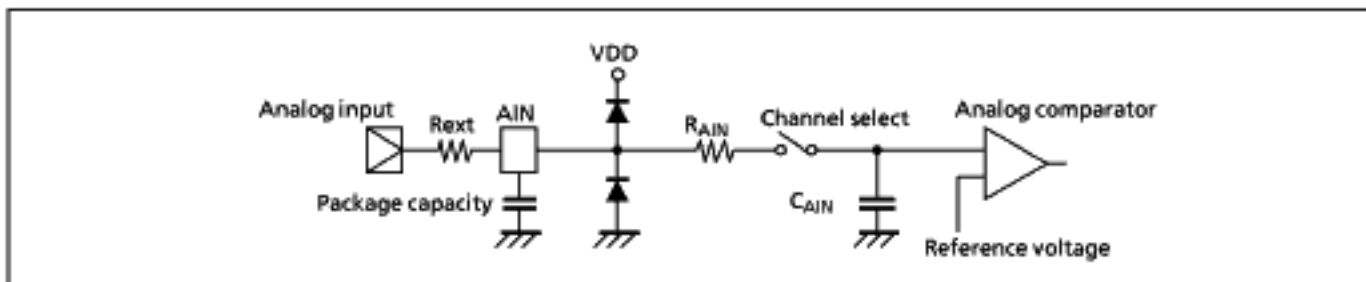

AD Pin Mode

AC Characteristics		(V <sub>SS</sub> = 0 V, T <sub>opr</sub> = -40 to 85°C)					
Parameter	Symbol	Conditions	V <sub>DD</sub>	Min	Typ.	Max	Unit
Machine cycle time	t <sub>cy</sub>	In NORMAL 1, 2 mode	4.5 to 5.5 V	0.5	-	10	μs
		In IDLE 1, 2 mode					
		In SLOW mode	2.7 to 5.5 V	117.6	-	133.3	
		In SLEEP mode					
High level clock pulse width	t <sub>WCH</sub>	For external clock operation (XIN input), f <sub>c</sub> = 8 MHz	4.5 to 5.5 V	62.5	-	-	ns
Low level clock pulse width	t <sub>WCL</sub>						
High level clock pulse width	t <sub>WSH</sub>	For external clock operation (XTIN input), f <sub>s</sub> = 32.768 kHz	2.7 to 5.5 V	14.7	-	-	μs
Low level clock pulse width	t <sub>WSL</sub>						
AD conversion time	t <sub>ADC</sub>	ADCCR bit 4 ; ACK = 0	-	-	49 t <sub>cy</sub>	-	ns
		ADCCR bit 4 ; ACK = 1	-	-	196 t <sub>cy</sub>	-	

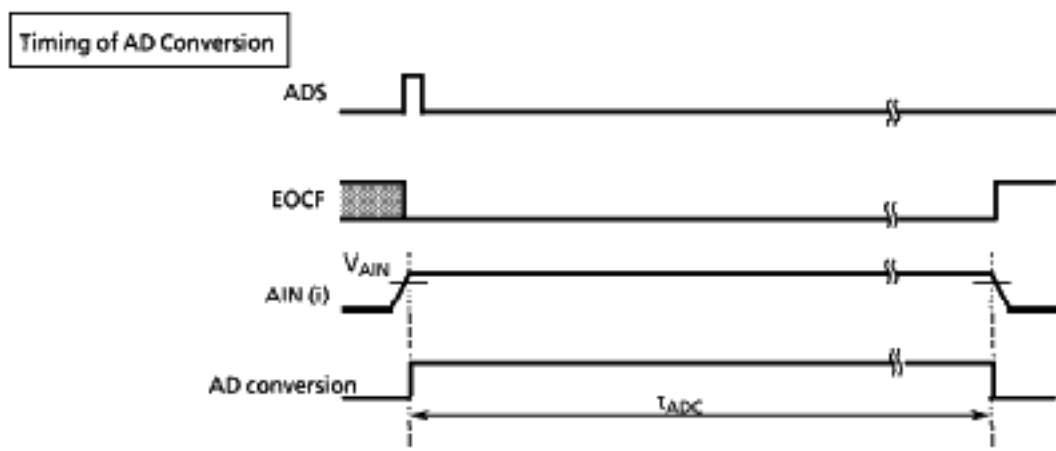

Note 1: During AD conversion, make the level of V<sub>AIN</sub> stable.  
 Note 2: i = 17 to 10, 07 to 00



**Recommended Oscillating Conditions** ( $V_{SS} = 0\text{ V}$ ,  $T_{opr} = -40\text{ to }85^{\circ}\text{C}$ )

Parameter	Oscillator	Oscillation Frequency	VDD	Recommended Oscillator	Recommended Constant	
					C <sub>1</sub>	C <sub>2</sub>
High-frequency oscillation	Ceramic resonator	8 MHz	4.5 to 5.5 V	KYOCERA KBR8.0 M	30 pF	30 pF
		4 MHz	2.7 to 5.5 V	KYOCERA KBR4.0 MS MURATA CSA4.00 MG		
	Crystal oscillator	8 MHz	4.5 to 5.5 V	TOYOCOM 210B 8.0000	20 pF	20 pF
		4 MHz	2.7 to 5.5 V	TOYOCOM 204B 4.0000		
Low-frequency oscillation	Crystal oscillator	32.768 kHz	2.7 to 5.5 V	NDK MX-38T	15 pF	15 pF

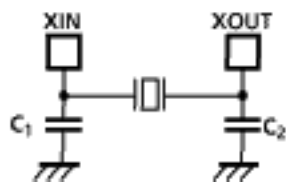

(1) High-frequency Oscillation

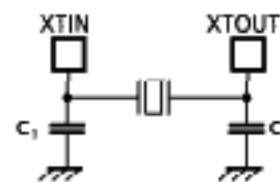

(2) Low-frequency Oscillation

**Note 1:** When it is used in high electrical field, an electrical shield of the package is recommended to retain normal operations.

**Note 2:** TOYAMA MURATA MFG. CO., LTD (JAPAN)

The product numbers and specifications of the resonators by Murata Manufacturing Co., Ltd. are subject to change.

For up-to-date information, please refer to the following URL;

<http://www.murata.co.jp/search/index.html>

**DC/AC Characteristics (PROM mode)** ( $V_{SS} = 0\text{ V}$ )

(1) Read operation

Parameter	Symbol	Conditions	Min	Typ.	Max	Unit
Input high voltage	$V_{IH4}$		2.2	–	$V_{CC}$	V
Input low voltage	$V_{IL4}$		0	–	0.8	V
Power supply voltage	$V_{CC}$		4.75	–	6.5	V
Program power supply voltage	$V_{PP}$					
Address access time	$t_{ACC}$	$V_{CC} = 5.0 \pm 0.25\text{ V}$	–	$1.5 t_{cyc} + 300$	–	ns

Note:  $t_{cyc} = 500\text{ ns}$  at 8 MHz

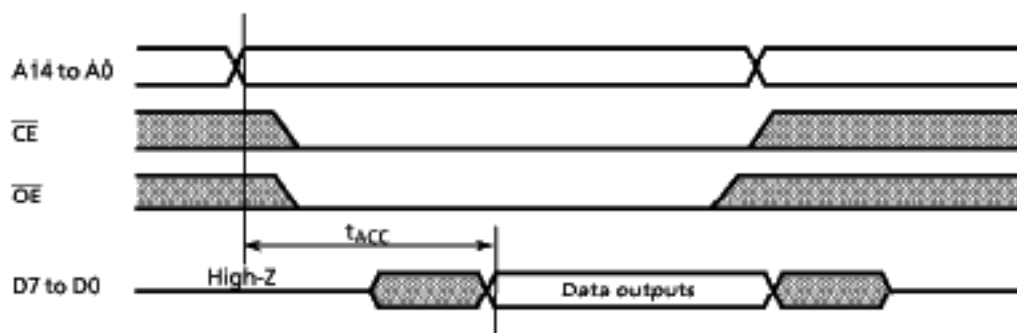

Timing Waveforms of Read Operation

(2) Program Operation (High-speed write mode - I ) ( $T_{opr} = 25 \pm 5^{\circ}\text{C}$ )

Parameter	Symbol	Conditions	Min	Typ.	Max	Unit
Input high voltage	$V_{IH4}$		2.2	-	$V_{CC}$	V
Input low voltage	$V_{IL4}$		0	-	0.8	V
Power supply voltage	$V_{CC}$		5.75	6.0	6.25	V
Program power supply voltage	$V_{PP}$		12.0	12.5	13.0	V
Initial program pulse width	$t_{PW}$	$V_{CC} = 6.0\text{V} \pm 0.25\text{V}$ , $V_{PP} = 12.5 \pm 0.5\text{V}$	0.95	1.0	1.05	ms

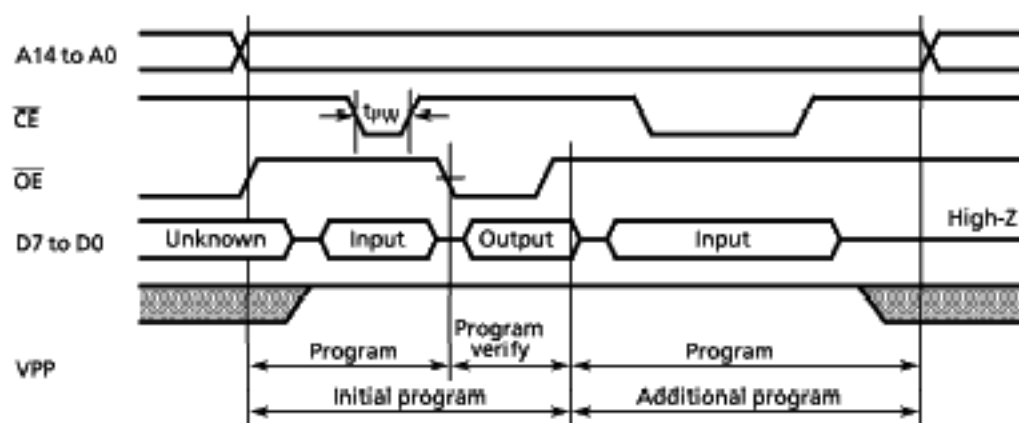

Timing Waveforms of Programming Operation

- Note 1:** When  $V_{CC}$  power supply is turned on or after,  $V_{PP}$  must be increased.  
When  $V_{CC}$  power supply is turned off or before,  $V_{PP}$  must be decreased.
- Note 2:** The device must not be set to the EPROM programmer or picked up from it under applying the program voltage ( $12.5\text{V} \pm 0.5\text{V}$ ) to the  $V_{PP}$  pin as the device is damaged.
- Note 3:** Be sure to execute the recommended programming mode with the recommended programming adaptor. If a mode or an adaptor except the above, the misoperation sometimes occurs.

(3) Program operation (High-speed write mode -II) ( $T_{opr} = 25 \pm 5^{\circ}\text{C}$ )

Parameter	Symbol	Conditions	Min	Typ.	Max	Unit
Input high voltage	$V_{IH4}$		2.2	-	$V_{CC}$	V
Input low voltage	$V_{IL4}$		0	-	0.8	V
Supply voltage	$V_{CC}$		6.00	6.25	6.50	V
Program supply voltage	$V_{PP}$		12.50	12.75	13.0	V
Initial program pulse width	$t_{PW}$	$V_{CC} = 6.25\text{ V} \pm 0.25\text{ V}$ , $V_{PP} = 12.75\text{ V} \pm 0.25\text{ V}$	0.095	0.1	0.105	ms

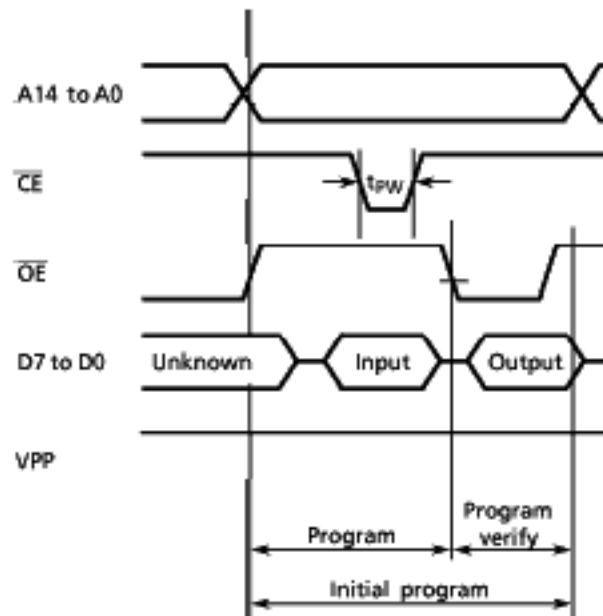

**Note 1:** When  $V_{CC}$  power supply is turned on or after,  $V_{PP}$  must be increased.

When  $V_{CC}$  power supply is turned off or before,  $V_{PP}$  must be decreased.

**Note 2:** The device must not be set to the EPROM programmer or picked up from it under applying the program voltage ( $12.75\text{ V} \pm 0.25\text{ V}$ ) to the  $V_{PP}$  pin as the device is damaged.

**Note 3:** Be sure to execute the recommended programming mode with the recommended programming adaptor. If a mode or an adaptor except the above, the misoperation sometimes occurs.