



2°C Accurate Digital Temperature Sensor with SPI™ Interface

FEATURES

- DIGITAL OUTPUT: SPI-Compatible Interface
- RESOLUTION: 10-Bit, 0.25°C
- ACCURACY:
±2.0°C (max) from –25°C to +85°C
±2.5°C (max) from –40°C to +125°C
- LOW QUIESCENT CURRENT: 50µA (max)
- WIDE SUPPLY RANGE: 2.7V to 5.5V
- TINY SOT23-6 PACKAGE
- OPERATION FROM –40°C to +125°C

APPLICATIONS

- BASE STATION EQUIPMENT
- COMPUTER PERIPHERAL THERMAL PROTECTION
- NOTEBOOK COMPUTERS
- DATA ACQUISITION SYSTEMS
- TELECOM EQUIPMENT
- OFFICE MACHINES

DESCRIPTION

The TMP125 is an SPI-compatible temperature sensor available in the tiny SOT23-6 package. Requiring no external components, the TMP125 is capable of measuring temperatures within 2°C of accuracy over a temperature range of –25°C to +85°C and 2.5°C of accuracy over –40°C to +125°C. Low supply current, and a supply range from 2.7V to 5.5V, make the TMP125 an excellent candidate for low-power applications.

The TMP125 is ideal for extended thermal measurement in a variety of communication, computer, consumer, environmental, industrial, and instrumentation applications.

TMP125 RELATED PRODUCTS

FEATURES	PRODUCT
2°C Digital Temp Sensors with Two-Wire Interface	TMP100/101
1.5°C Digital Temp Sensors with Two-Wire Interface	TMP75/175
1.5°C Digital Temp Sensors with SPI	TMP121/123
1.5°C Programmable Digital Temp Sensors with SPI	TMP122/124

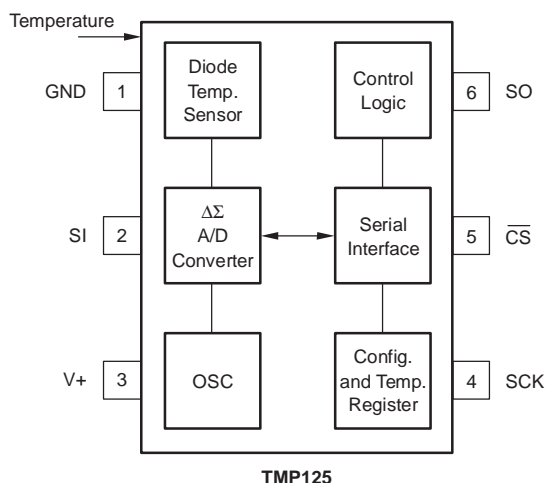

Please be aware that an important notice concerning availability, standard warranty, and use in critical applications of Texas Instruments semiconductor products and disclaimers thereto appears at the end of this data sheet.

SPI is a registered trademark of Motorola. All other trademarks are the property of their respective owners.

ABSOLUTE MAXIMUM RATINGS(1)

Supply Voltage	+7V
Input Voltage(2)	-0.3V to +7V
Input Current	±10mA
Output Short Circuit(3)	Continuous
Operating Temperature Range	-55°C to +125°C
Storage Temperature Range	-60°C to +150°C
Junction Temperature (T _J max)	+150°C
Lead Temperature (soldering)	+300°C
ESD Rating (Human Body Model)	4000V
(Charged Device Model)	1000V



This integrated circuit can be damaged by ESD. Texas Instruments recommends that all integrated circuits be handled with appropriate precautions. Failure to observe proper handling and installation procedures can cause damage.

ESD damage can range from subtle performance degradation to complete device failure. Precision integrated circuits may be more susceptible to damage because very small parametric changes could cause the device not to meet its published specifications.

- (1) Stresses above these ratings may cause permanent damage. Exposure to absolute maximum conditions for extended periods may degrade device reliability. These are stress ratings only, and functional operation of the device at these or any other conditions beyond those specified is not supported.
- (2) Input terminals are diode-clamped to the power-supply rails. Input signals that can swing more than 0.5V beyond the supply rails should be current limited to 10mA or less.
- (3) Short-circuit to ground.

ORDERING INFORMATION(1)

PRODUCT	PACKAGE-LEAD	PACKAGE DESIGNATOR	PACKAGE MARKING
TMP125	SOT23-6	DBV	T125

(1) For the most current package and ordering information, see the Package Option Addendum at the end of this document, or see the TI web site at www.ti.com.

PIN CONFIGURATION

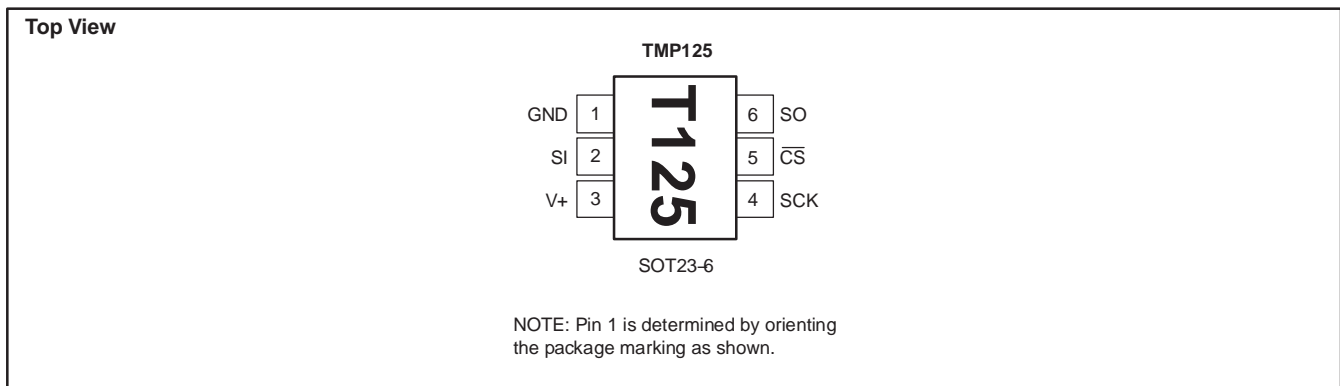

ELECTRICAL CHARACTERISTICS

 At $T_A = -40^\circ\text{C}$ to $+125^\circ\text{C}$ and $V_S = +2.7\text{V}$ to 5.5V , unless otherwise noted.

PARAMETER	CONDITIONS	TMP125			UNIT
		MIN	TYP	MAX	
TEMPERATURE INPUT					
Range		-40		+125	$^\circ\text{C}$
Accuracy (temperature error)	-25 $^\circ\text{C}$ to +85 $^\circ\text{C}$		± 0.5	± 2.0	$^\circ\text{C}$
	-40 $^\circ\text{C}$ to +125 $^\circ\text{C}$		± 1.0	± 2.5	$^\circ\text{C}$
Resolution			10		Bits
Temperature Measurement Noise			0.1		LSB
DIGITAL INPUT/OUTPUT					
Input Logic Levels:					
V_{IH}		0.7(V+)			V
V_{IL}				0.3(V+)	V
Input Current, SI, SCK, $\overline{\text{CS}}$	I_{IN} 0V = $V_{IN} = V+$			± 1	μA
Output Logic Levels:					
$V_{OL\ SO}$	$I_{SINK} = 3\text{mA}$			0.4	V
$V_{OH\ SO}$	$I_{SOURCE} = 2\text{mA}$	(V+)-0.4			V
Input Capacitance, SI, SCK, $\overline{\text{CS}}$			2.5		pF
Conversion Time	10-Bit		60		ms
Update Rate			120		ms
POWER SUPPLY					
Operating Range		2.7		5.5	V
Quiescent Current, at $T_A = 25^\circ\text{C}$	I_Q Serial Bus Inactive		36	50	μA
over Temperature	-40 $^\circ\text{C}$ to +125 $^\circ\text{C}$			60	μA
Shutdown Current			0.1	1	μA
over Temperature				1	μA
TEMPERATURE RANGE					
Specified Range		-40		+125	$^\circ\text{C}$
Operating Range		-55		+125	$^\circ\text{C}$
Storage Range		-60		+150	$^\circ\text{C}$
Thermal Resistance	θ_{JA} SOT23-6 Surface-Mount		200		$^\circ\text{C}/\text{W}$

TYPICAL CHARACTERISTICS

At $T_A = -40^\circ\text{C}$ to $+125^\circ\text{C}$ and $V_S = +2.7\text{V}$ to 5.5V , unless otherwise noted.

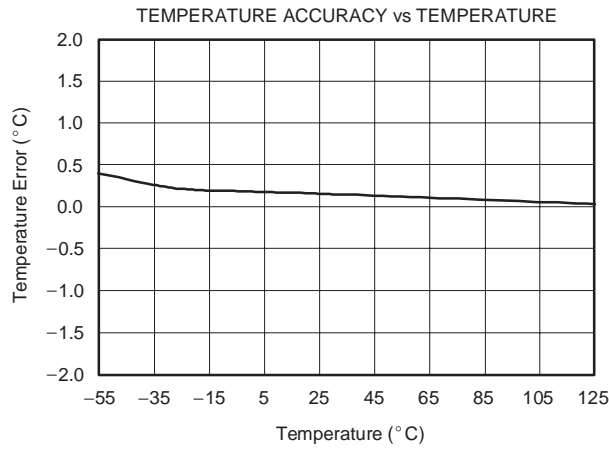
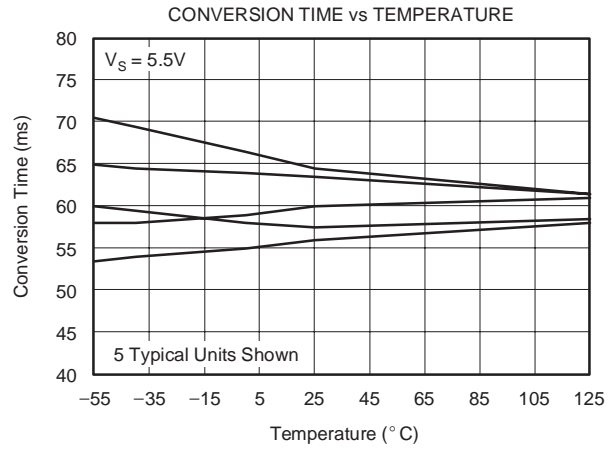
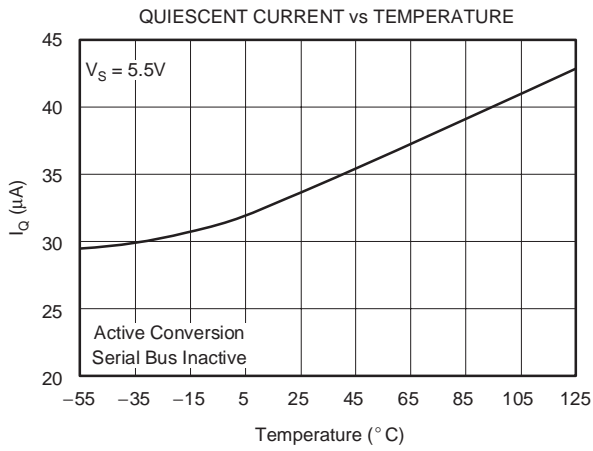

APPLICATIONS

The TMP125 10-bit, read-only digital temperature sensor is optimal for thermal management and thermal protection applications. The TMP125 is specified for a temperature range of -40°C to $+125^{\circ}\text{C}$, with operation extending down to -55°C . It is specified for a supply voltage range of 2.7V to 5.5V, and also features a hardware shutdown to provide power savings. Quiescent current is reduced to $1\mu\text{A}$ during analog shutdown.

The TMP125 communicates through a serial interface that is SPI-compatible. Temperature is converted to a 10-bit data word with 0.25°C resolution. The TMP125 is optimal for low-power applications, with a 120ms conversion period for reduced power consumption.

The sensing device of the TMP125 is the chip itself. Thermal paths run through the package leads as well as the plastic package, and the lower thermal resistance of metal causes the leads to provide the primary thermal path.

The TMP125 requires no external components for operation, though a $0.1\mu\text{F}$ supply bypass capacitor is recommended. Figure 1 shows typical connection for the TMP125.

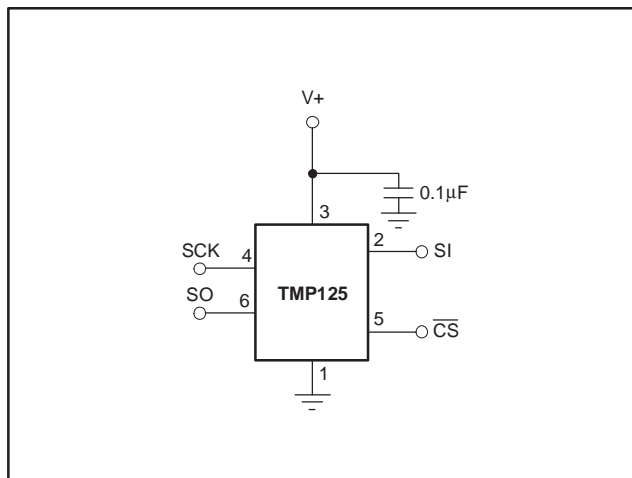

Figure 1. Typical Connections for the TMP125

COMMUNICATING WITH THE TMP125

The TMP125 continuously converts temperatures to digital data. Temperature data is read by pulling $\overline{\text{CS}}$ low. Once $\overline{\text{CS}}$ is pulled low, temperature data from the last completed conversion prior to dropping $\overline{\text{CS}}$ is latched into the shift register and clocked out at SO on the falling SCK edge. The 16-bit data word is clocked out sign bit first, followed by the MSB. The SI pin is used to put the device into shutdown mode. To enter shutdown mode, SI must be high on the rising edge of the third bit of SCK (see Figure 3). Also, all 16 bits must be clocked to allow shutdown on the TMP125. To bring the device out of

shutdown, perform a 16-clock communication with SI set to logic low. The 16-clock communication is the same as the Data Read shown in Figure 3, except that the data on SO will be the last conversion prior to putting the device into shutdown mode. Note that SO is only used to control the shutdown function; if not using this function, connect this pin to ground.

The one-shot command can be used to force a single conversion. When the command is issued, the part will perform a single conversion and then go into shutdown mode. After the conversion is complete, the conversion result should be read with the power-down bit high (see Figure 3) if you do not want to start a new conversion.

The TMP125 will go into idle mode for 60ms, requiring only $20\mu\text{A}$ of current. A new conversion begins every 120ms. Figure 2 describes the conversion timing for the TMP125.

TEMPERATURE REGISTER

The Temperature Register of the TMP125 is a 16-bit, read-only register that stores the output of the most recent conversion. However, temperature is represented by only 10-bits, which are in signed two's complement format. The first bit of the Temperature Register, D15, is a leading zero. Bits D14 and D5 are used to indicate temperature. Bits D4 to D0 are the same as D5 (see Table 1). Data format for temperature is summarized in Table 2. When calculating the signed two's complement temperature value, be sure to use only the 10 data bits.

Following power-up or reset, the Temperature Register will read 0°C until the first conversion is complete.

D15	D14	D13	D12	D11	D10	D9	D8
0	T9	T8	T7	T6	T5	T4	T3
D7	D6	D5	D4	D3	D2	D1	D0
T2	T1	T0	T0	T0	T0	T0	T0

Table 1. Temperature Register

TEMPERATURE ($^{\circ}\text{C}$)	DIGITAL OUTPUT D14...D5
+127	01 1111 1100
+125	01 1111 0100
+100	01 1001 0000
+75	01 0010 1100
+50	00 1100 1000
+25	00 0110 0100
+10	00 0010 1000
+0.25	00 0000 0001
0	00 0000 0000
-0.25	11 1111 1111
-25	11 1001 1100
-50	11 0011 1000
-55	11 0010 0100

Table 2. Temperature Data Format

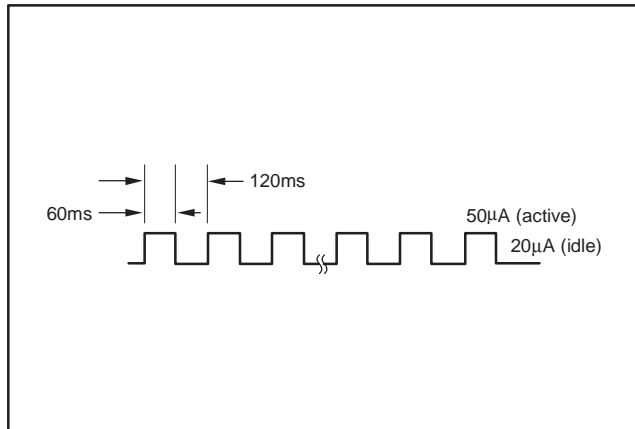

Figure 2. Conversion Time and Period

Timing Diagrams

The TMP125 is SPI-compatible. Figure 3 and Figure 4 describe the output data of the TMP125. Figure 5, Figure 6, and Figure 7 describe the various timing requirements, with parameters defined in Table 3.

PARAMETER	MIN	MAX	UNITS
SCK Period	t_1	100	ns
Data In to Rising Edge SCK Setup Time	t_2	20	ns
SCK Falling Edge to Output Data Delay	t_3	30	ns
SCK Rising Edge to Input Data Hold Time	t_4	20	ns
\overline{CS} to Rising Edge SCK Set-Up Time	t_5	40	ns
\overline{CS} to Output Data Delay	t_6	30	ns
\overline{CS} Rising Edge to Output High Impedance	t_7	30	ns

Table 3. Timing Description

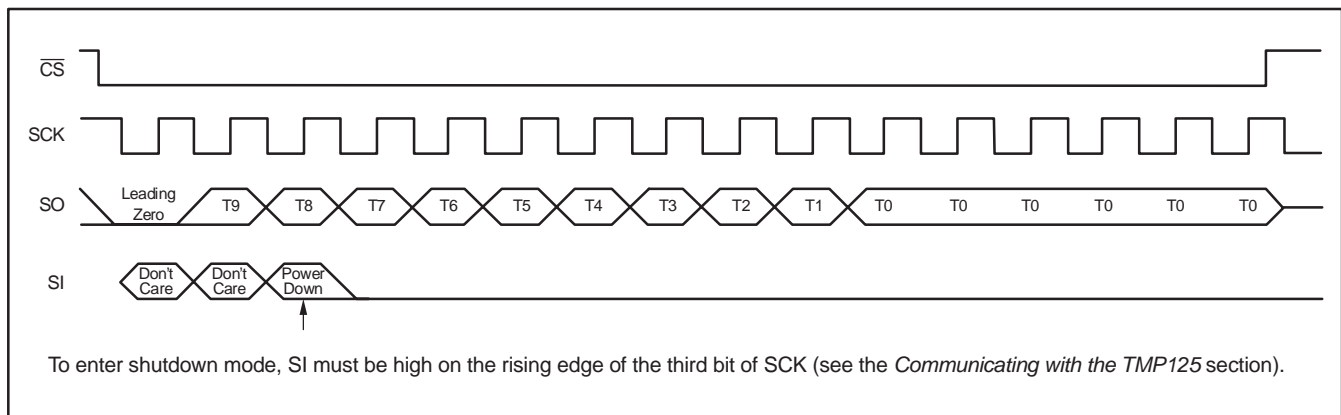

Figure 3. Data READ

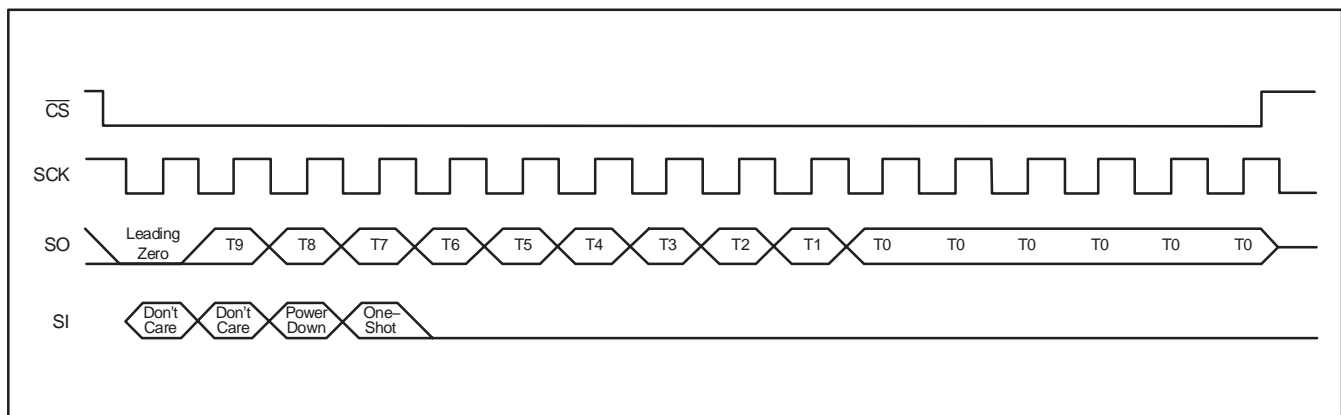

Figure 4. One-Shot Command

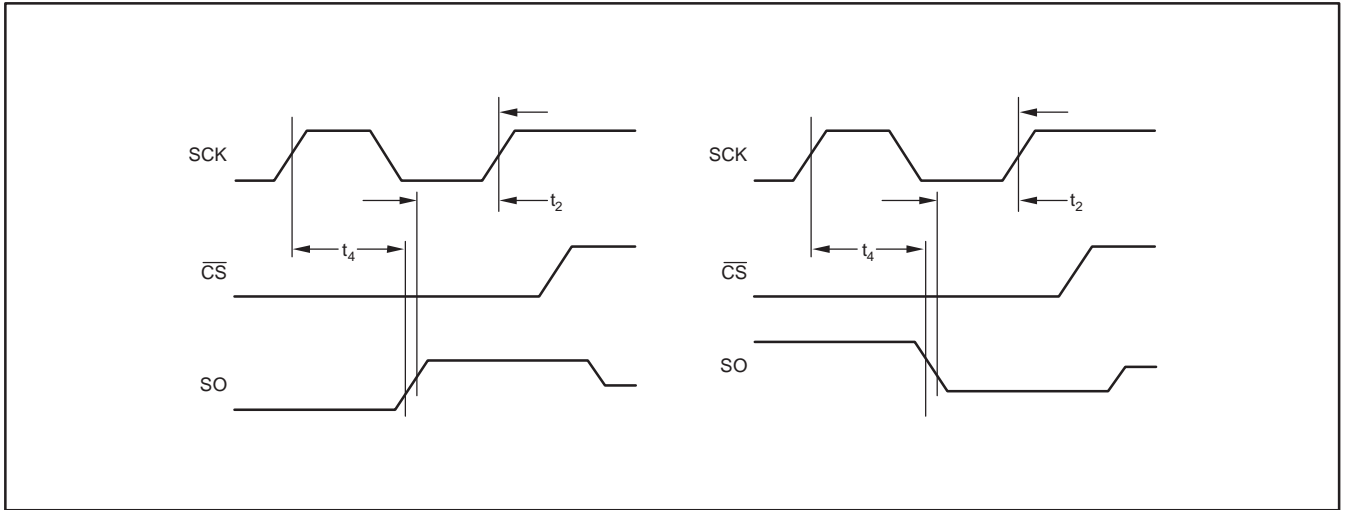

Figure 5. Input Data Timing Diagram

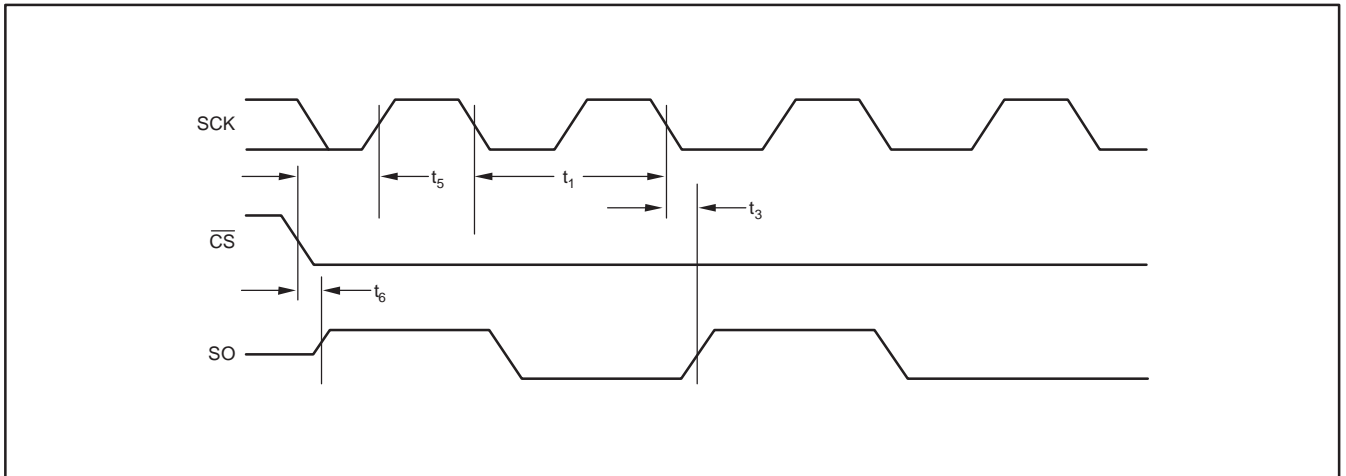

Figure 6. Output Data Timing Diagram

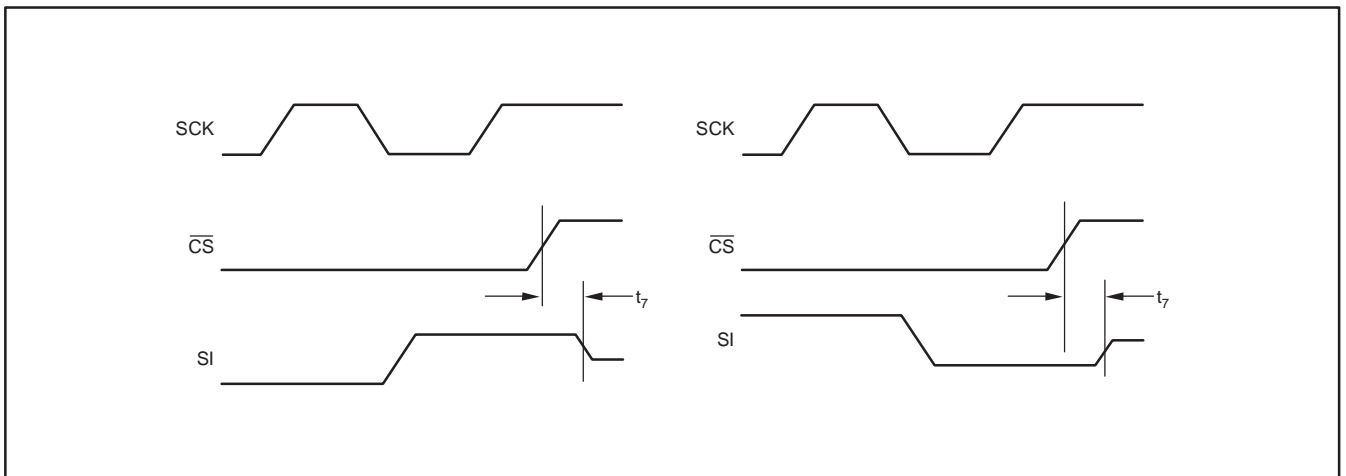

Figure 7. High Impedance Output Timing Diagram

PACKAGING INFORMATION

Orderable Device	Status (1)	Package Type	Package Drawing	Pins	Package Qty	Eco Plan (2)	Lead/Ball Finish (6)	MSL Peak Temp (3)	Op Temp (°C)	Device Marking (4/5)	Samples
HPA00444AIDBVR	ACTIVE	SOT-23	DBV	6	3000	Green (RoHS & no Sb/Br)	CU NIPDAU	Level-2-260C-1 YEAR	-40 to 125	T125	Samples
HPA00444AIDBVT	ACTIVE	SOT-23	DBV	6	250	Green (RoHS & no Sb/Br)	CU NIPDAU	Level-2-260C-1 YEAR	-40 to 125	T125	Samples
TMP125AIDBVR	ACTIVE	SOT-23	DBV	6	3000	Green (RoHS & no Sb/Br)	CU NIPDAU	Level-2-260C-1 YEAR	-40 to 125	T125	Samples
TMP125AIDBVRG4	ACTIVE	SOT-23	DBV	6	3000	Green (RoHS & no Sb/Br)	CU NIPDAU	Level-2-260C-1 YEAR	-40 to 125	T125	Samples
TMP125AIDBVT	ACTIVE	SOT-23	DBV	6	250	Green (RoHS & no Sb/Br)	CU NIPDAU	Level-2-260C-1 YEAR	-40 to 125	T125	Samples
TMP125AIDBVTG4	ACTIVE	SOT-23	DBV	6	250	Green (RoHS & no Sb/Br)	CU NIPDAU	Level-2-260C-1 YEAR	-40 to 125	T125	Samples

(1) The marketing status values are defined as follows:

ACTIVE: Product device recommended for new designs.

LIFEBUY: TI has announced that the device will be discontinued, and a lifetime-buy period is in effect.

NRND: Not recommended for new designs. Device is in production to support existing customers, but TI does not recommend using this part in a new design.

PREVIEW: Device has been announced but is not in production. Samples may or may not be available.

OBSELETE: TI has discontinued the production of the device.

(2) Eco Plan - The planned eco-friendly classification: Pb-Free (RoHS), Pb-Free (RoHS Exempt), or Green (RoHS & no Sb/Br) - please check <http://www.ti.com/productcontent> for the latest availability information and additional product content details.

TBD: The Pb-Free/Green conversion plan has not been defined.

Pb-Free (RoHS): TI's terms "Lead-Free" or "Pb-Free" mean semiconductor products that are compatible with the current RoHS requirements for all 6 substances, including the requirement that lead not exceed 0.1% by weight in homogeneous materials. Where designed to be soldered at high temperatures, TI Pb-Free products are suitable for use in specified lead-free processes.

Pb-Free (RoHS Exempt): This component has a RoHS exemption for either 1) lead-based flip-chip solder bumps used between the die and package, or 2) lead-based die adhesive used between the die and leadframe. The component is otherwise considered Pb-Free (RoHS compatible) as defined above.

Green (RoHS & no Sb/Br): TI defines "Green" to mean Pb-Free (RoHS compatible), and free of Bromine (Br) and Antimony (Sb) based flame retardants (Br or Sb do not exceed 0.1% by weight in homogeneous material)

(3) MSL, Peak Temp. - The Moisture Sensitivity Level rating according to the JEDEC industry standard classifications, and peak solder temperature.

(4) There may be additional marking, which relates to the logo, the lot trace code information, or the environmental category on the device.

(5) Multiple Device Markings will be inside parentheses. Only one Device Marking contained in parentheses and separated by a "~" will appear on a device. If a line is indented then it is a continuation of the previous line and the two combined represent the entire Device Marking for that device.

⁽⁶⁾ Lead/Ball Finish - Orderable Devices may have multiple material finish options. Finish options are separated by a vertical ruled line. Lead/Ball Finish values may wrap to two lines if the finish value exceeds the maximum column width.

Important Information and Disclaimer: The information provided on this page represents TI's knowledge and belief as of the date that it is provided. TI bases its knowledge and belief on information provided by third parties, and makes no representation or warranty as to the accuracy of such information. Efforts are underway to better integrate information from third parties. TI has taken and continues to take reasonable steps to provide representative and accurate information but may not have conducted destructive testing or chemical analysis on incoming materials and chemicals. TI and TI suppliers consider certain information to be proprietary, and thus CAS numbers and other limited information may not be available for release.

In no event shall TI's liability arising out of such information exceed the total purchase price of the TI part(s) at issue in this document sold by TI to Customer on an annual basis.

MECHANICAL DATA

DBV (R-PDSO-G6)

PLASTIC SMALL-OUTLINE PACKAGE

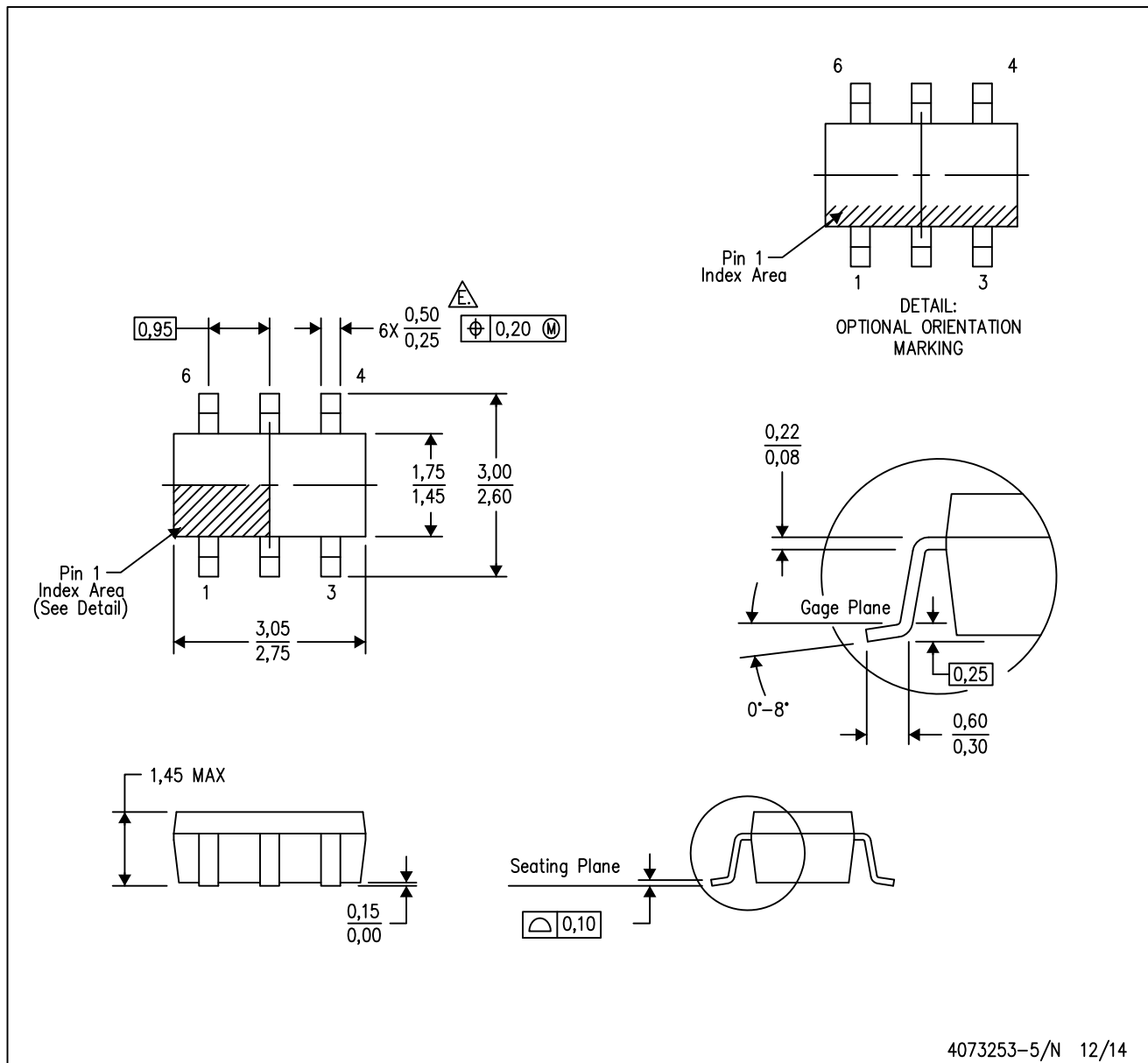

- NOTES:
- A. All linear dimensions are in millimeters.
 - B. This drawing is subject to change without notice.
 - C. Body dimensions do not include mold flash or protrusion. Mold flash and protrusion shall not exceed 0.15 per side.
 - D. Leads 1,2,3 may be wider than leads 4,5,6 for package orientation.
- Falls within JEDEC MO-178 Variation AB, except minimum lead width.

DBV (R-PDSO-G6)

PLASTIC SMALL OUTLINE



- NOTES:
- A. All linear dimensions are in millimeters.
 - B. This drawing is subject to change without notice.
 - C. Customers should place a note on the circuit board fabrication drawing not to alter the center solder mask defined pad.
 - D. Publication IPC-7351 is recommended for alternate designs.
 - E. Laser cutting apertures with trapezoidal walls and also rounding corners will offer better paste release. Customers should contact their board assembly site for stencil design recommendations. Example stencil design based on a 50% volumetric metal load solder paste. Refer to IPC-7525 for other stencil recommendations.

IMPORTANT NOTICE

Texas Instruments Incorporated (TI) reserves the right to make corrections, enhancements, improvements and other changes to its semiconductor products and services per JESD46, latest issue, and to discontinue any product or service per JESD48, latest issue. Buyers should obtain the latest relevant information before placing orders and should verify that such information is current and complete.

TI's published terms of sale for semiconductor products (<http://www.ti.com/sc/docs/stdterms.htm>) apply to the sale of packaged integrated circuit products that TI has qualified and released to market. Additional terms may apply to the use or sale of other types of TI products and services.

Reproduction of significant portions of TI information in TI data sheets is permissible only if reproduction is without alteration and is accompanied by all associated warranties, conditions, limitations, and notices. TI is not responsible or liable for such reproduced documentation. Information of third parties may be subject to additional restrictions. Resale of TI products or services with statements different from or beyond the parameters stated by TI for that product or service voids all express and any implied warranties for the associated TI product or service and is an unfair and deceptive business practice. TI is not responsible or liable for any such statements.

Buyers and others who are developing systems that incorporate TI products (collectively, "Designers") understand and agree that Designers remain responsible for using their independent analysis, evaluation and judgment in designing their applications and that Designers have full and exclusive responsibility to assure the safety of Designers' applications and compliance of their applications (and of all TI products used in or for Designers' applications) with all applicable regulations, laws and other applicable requirements. Designer represents that, with respect to their applications, Designer has all the necessary expertise to create and implement safeguards that (1) anticipate dangerous consequences of failures, (2) monitor failures and their consequences, and (3) lessen the likelihood of failures that might cause harm and take appropriate actions. Designer agrees that prior to using or distributing any applications that include TI products, Designer will thoroughly test such applications and the functionality of such TI products as used in such applications.

TI's provision of technical, application or other design advice, quality characterization, reliability data or other services or information, including, but not limited to, reference designs and materials relating to evaluation modules, (collectively, "TI Resources") are intended to assist designers who are developing applications that incorporate TI products; by downloading, accessing or using TI Resources in any way, Designer (individually or, if Designer is acting on behalf of a company, Designer's company) agrees to use any particular TI Resource solely for this purpose and subject to the terms of this Notice.

TI's provision of TI Resources does not expand or otherwise alter TI's applicable published warranties or warranty disclaimers for TI products, and no additional obligations or liabilities arise from TI providing such TI Resources. TI reserves the right to make corrections, enhancements, improvements and other changes to its TI Resources. TI has not conducted any testing other than that specifically described in the published documentation for a particular TI Resource.

Designer is authorized to use, copy and modify any individual TI Resource only in connection with the development of applications that include the TI product(s) identified in such TI Resource. NO OTHER LICENSE, EXPRESS OR IMPLIED, BY ESTOPPEL OR OTHERWISE TO ANY OTHER TI INTELLECTUAL PROPERTY RIGHT, AND NO LICENSE TO ANY TECHNOLOGY OR INTELLECTUAL PROPERTY RIGHT OF TI OR ANY THIRD PARTY IS GRANTED HEREIN, including but not limited to any patent right, copyright, mask work right, or other intellectual property right relating to any combination, machine, or process in which TI products or services are used. Information regarding or referencing third-party products or services does not constitute a license to use such products or services, or a warranty or endorsement thereof. Use of TI Resources may require a license from a third party under the patents or other intellectual property of the third party, or a license from TI under the patents or other intellectual property of TI.

TI RESOURCES ARE PROVIDED "AS IS" AND WITH ALL FAULTS. TI DISCLAIMS ALL OTHER WARRANTIES OR REPRESENTATIONS, EXPRESS OR IMPLIED, REGARDING RESOURCES OR USE THEREOF, INCLUDING BUT NOT LIMITED TO ACCURACY OR COMPLETENESS, TITLE, ANY EPIDEMIC FAILURE WARRANTY AND ANY IMPLIED WARRANTIES OF MERCHANTABILITY, FITNESS FOR A PARTICULAR PURPOSE, AND NON-INFRINGEMENT OF ANY THIRD PARTY INTELLECTUAL PROPERTY RIGHTS. TI SHALL NOT BE LIABLE FOR AND SHALL NOT DEFEND OR INDEMNIFY DESIGNER AGAINST ANY CLAIM, INCLUDING BUT NOT LIMITED TO ANY INFRINGEMENT CLAIM THAT RELATES TO OR IS BASED ON ANY COMBINATION OF PRODUCTS EVEN IF DESCRIBED IN TI RESOURCES OR OTHERWISE. IN NO EVENT SHALL TI BE LIABLE FOR ANY ACTUAL, DIRECT, SPECIAL, COLLATERAL, INDIRECT, PUNITIVE, INCIDENTAL, CONSEQUENTIAL OR EXEMPLARY DAMAGES IN CONNECTION WITH OR ARISING OUT OF TI RESOURCES OR USE THEREOF, AND REGARDLESS OF WHETHER TI HAS BEEN ADVISED OF THE POSSIBILITY OF SUCH DAMAGES.

Unless TI has explicitly designated an individual product as meeting the requirements of a particular industry standard (e.g., ISO/TS 16949 and ISO 26262), TI is not responsible for any failure to meet such industry standard requirements.

Where TI specifically promotes products as facilitating functional safety or as compliant with industry functional safety standards, such products are intended to help enable customers to design and create their own applications that meet applicable functional safety standards and requirements. Using products in an application does not by itself establish any safety features in the application. Designers must ensure compliance with safety-related requirements and standards applicable to their applications. Designer may not use any TI products in life-critical medical equipment unless authorized officers of the parties have executed a special contract specifically governing such use. Life-critical medical equipment is medical equipment where failure of such equipment would cause serious bodily injury or death (e.g., life support, pacemakers, defibrillators, heart pumps, neurostimulators, and implantables). Such equipment includes, without limitation, all medical devices identified by the U.S. Food and Drug Administration as Class III devices and equivalent classifications outside the U.S.

TI may expressly designate certain products as completing a particular qualification (e.g., Q100, Military Grade, or Enhanced Product). Designers agree that it has the necessary expertise to select the product with the appropriate qualification designation for their applications and that proper product selection is at Designers' own risk. Designers are solely responsible for compliance with all legal and regulatory requirements in connection with such selection.

Designer will fully indemnify TI and its representatives against any damages, costs, losses, and/or liabilities arising out of Designer's non-compliance with the terms and provisions of this Notice.