

TLV8x3 3-Pin Voltage Supervisors with Active-Low, Open-Drain Reset

1 Features

- 3-Pin SOT23 Package
- Supply Current: 9 μ A (Typical)
- Precision Supply Voltage Monitor: 2.5 V, 3 V, 3.3 V, 5 V
- Power-On Reset Generator with Fixed Delay Time of 200 ms
- Pin-for-Pin Compatible with MAX803
- Temperature Range: -40°C to $+125^{\circ}\text{C}$
- Open-Drain, $\overline{\text{RESET}}$ Output

2 Applications

- DSPs, Microcontrollers, and Microprocessors
- Portable and Battery-Powered Equipment
- Set-Top Boxes
- Servers
- Appliances
- Programmable Controls
- Intelligent Instruments
- Industrial Equipment
- Automotive Systems

3 Description

The TLV8x3 family of supervisory circuits provides circuit initialization and timing supervision, primarily for DSPs and processor-based systems.

The TLV803, TLV853, and TLV863 are functionally equivalent. The TLV853 and TLV863 provide an alternate pinout of the TLV803.

During power on, $\overline{\text{RESET}}$ asserts when the supply voltage (V_{DD}) exceeds 1.1 V. Thereafter, the supervisory circuit monitors V_{DD} and keeps $\overline{\text{RESET}}$ active as long as V_{DD} remains below the threshold voltage V_{IT} . An internal timer delays the return of the output to the inactive state (high) to ensure proper system reset. The delay time ($t_{\text{d(typ)}} = 200$ ms) starts after V_{DD} exceeds the threshold voltage, V_{IT} . When the supply voltage drops below the V_{IT} threshold voltage, the output is active (low) again. All the devices in this family have a fixed sense-threshold voltage (V_{IT}) set by an internal voltage divider.

The product spectrum is designed for supply voltages of 2.5 V, 3 V, 3.3 V, and 5 V. These devices are available in a 3-pin SOT-23 package. The TLV803 devices are characterized for operation over a temperature range of -40°C to $+125^{\circ}\text{C}$.

Device Information⁽¹⁾

PART NUMBER	PACKAGE	BODY SIZE (NOM)
TLV8x3	SOT-23 (3)	2.92 mm x 1.30 mm

(1) For all available packages, see the package option addendum at the end of the data sheet.

Typical Application

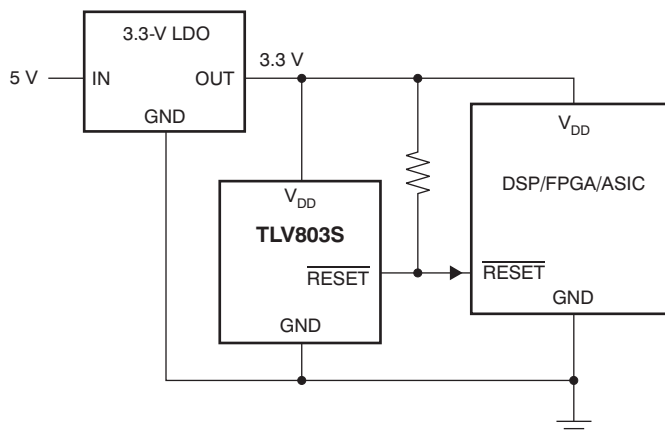

Table of Contents

1 Features	1	8.4 Device Functional Modes.....	8
2 Applications	1	9 Application and Implementation	9
3 Description	1	9.1 Application Information.....	9
4 Revision History	2	9.2 Typical Application	10
5 Device Comparison	3	10 Power Supply Recommendations	11
6 Pin Configuration and Functions	3	11 Layout	11
7 Specifications	4	11.1 Layout Guidelines	11
7.1 Absolute Maximum Ratings	4	11.2 Layout Example	11
7.2 ESD Ratings.....	4	12 Device and Documentation Support	12
7.3 Thermal Information	4	12.1 Device Support	12
7.4 Recommended Operating Conditions.....	4	12.2 Documentation Support	12
7.5 Electrical Characteristics.....	5	12.3 Related Links	12
7.6 Switching Characteristics	5	12.4 Community Resources.....	12
7.7 Typical Characteristics	6	12.5 Trademarks	13
8 Detailed Description	7	12.6 Electrostatic Discharge Caution.....	13
8.1 Overview	7	12.7 Glossary	13
8.2 Functional Block Diagram	7	13 Mechanical, Packaging, and Orderable	13
8.3 Feature Description.....	7	Information	13

4 Revision History

NOTE: Page numbers for previous revisions may differ from page numbers in the current version.

Changes from Revision B (August 2011) to Revision C	Page
• Added TLV853 device to data sheet	1
• Changed device part numbers shown on page header to show single TLV803 device instead of lettered-device versions	1
• Added <i>Device Information</i> and <i>ESD Ratings</i> tables.....	1
• Added <i>Detailed Description</i> , <i>Application and Implementation</i> , <i>Power-Supply Recommendations</i> , <i>Layout</i> , <i>Device and Documentation Support</i> , and <i>Mechanical, Packaging, and Orderable Information</i> sections	1
• Changed <i>Applications</i> section bullets	1
• Deleted pinouts from front page and moved to <i>Pin Configurations and Functions</i> section	1
• Deleted Package/Ordering Information table; for package and ordering information, see the package option addendum at the end of the data sheet.	3
• Changed all "free-air" to "junction" and all "T _A " to "T _J " for all temperature ranges throughout data sheet	4
• Changed "free-air temperature" to "junction temperature" in <i>Absolute Maximum Ratings</i> condition statement	4
• Deleted <i>Soldering temperature</i> from <i>Absolute Maximum Ratings</i> table	4
• Changed <i>Thermal Information</i> table; updated thermal resistance values for all parameters	4
• Changed "free-air temperature" to "junction temperature" in <i>Electrical Characteristics</i> condition statement	5
• Changed temperature noted in <i>Switching Characteristics</i> condition statement	5

Changes from Revision A (June 2011) to Revision B	Page
• Added new paragraph regarding TLV863 to <i>Description</i> section.....	1
• Added TLV863 pinout to front page	1
• Added TLV863M to Package/Ordering Information.....	3
• Added TLV863 to Thermal Information	4
• Added TLV863M to Negative-Going Input Threshold Voltage parameter.....	5
• Added TLV863M to Hysteresis parameter	5
• Added TLV863 to Functional Block Diagram	7

5 Device Comparison

Table 1. Device Threshold Options

DEVICE	THRESHOLD VOLTAGE
TLV803Z	2.25 V
TLV803R	2.64 V
TLV803S	2.93 V
TLV803M	4.38 V
TLV853M	4.38 V
TLV863M	4.38 V

Table 2. Device Family Comparison

DEVICE	FUNCTION
TLV803	Open-Drain, $\overline{\text{RESET}}$ Output
TLV809	Push-Pull, $\overline{\text{RESET}}$ Output
TLV810	Push-Pull, RESET Output

6 Pin Configuration and Functions

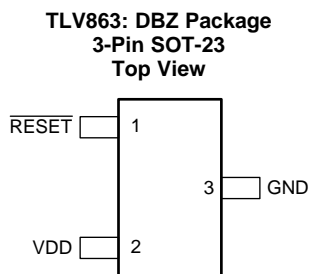
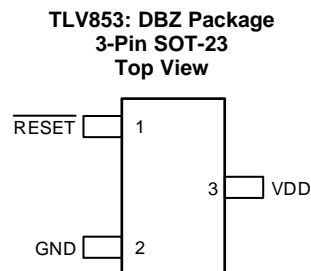
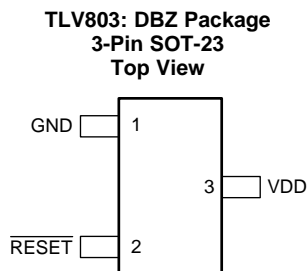

Pin Functions

NAME	PIN			I/O	DESCRIPTION
	TLV803	TLV853	TLV863		
GND	1	2	3	—	Ground pin.
$\overline{\text{RESET}}$	2	1	1	O	$\overline{\text{RESET}}$ is an open-drain output that is driven to a low impedance state when $\overline{\text{RESET}}$ is asserted. $\overline{\text{RESET}}$ remains low (asserted) for the delay time (t_d) after V_{DD} exceeds V_{IT-} . Use a 10-k Ω to 1-M Ω pullup resistor on this pin. The pullup voltage is not limited by V_{DD} .
VDD	3	3	2	I	Supply voltage pin. It is good analog design practice to place a 0.1- μF ceramic capacitor close to this pin.

7 Specifications

7.1 Absolute Maximum Ratings⁽¹⁾

over operating junction temperature range (unless otherwise noted)

		MIN	MAX	UNIT
Voltage	VDD ⁽²⁾	0	7	V
	All other pins ⁽²⁾	-0.3	+7	
Current	Maximum low output current, I _{OL}		5	mA
	Maximum high output current, I _{OH}		-5	
	Input clamp current, I _{IK} (V _I < 0 or V _I > V _{DD})		±20	
	Output clamp current, I _{OK} (V _O < 0 or V _O > V _{DD})		±20	
Temperature	Operating junction temperature range, T _J	-40	125	°C
	Storage temperature range, T _{stg}	-65	150	

- (1) Stresses beyond those listed under *Absolute Maximum Ratings* may cause permanent damage to the device. These are stress ratings only, and functional operation of the device at these or any other conditions beyond those indicated under *Recommended Operating Conditions* is not implied. Exposure to absolute-maximum-rated conditions for extended periods may affect device reliability.
- (2) All voltage values are with respect to GND. For reliable operation the device should not be operated at 7 V for more than t = 1000h continuously

7.2 ESD Ratings

		VALUE	UNIT
V _(ESD)	Electrostatic discharge	Human-body model (HBM), per ANSI/ESDA/JEDEC JS-001 ⁽¹⁾	±2000
		Charged-device model (CDM), per JEDEC specification JESD22-C101 ⁽²⁾	±500

- (1) JEDEC document JEP155 states that 500-V HBM allows safe manufacturing with a standard ESD control process.
- (2) JEDEC document JEP157 states that 250-V CDM allows safe manufacturing with a standard ESD control process.

7.3 Thermal Information

THERMAL METRIC ⁽¹⁾		TLV8x3	UNITS
		DBZ (SOT-23)	
		3 PINS	
R _{θJA}	Junction-to-ambient thermal resistance	328.5	°C/W
R _{θJC(top)}	Junction-to-case (top) thermal resistance	135.4	°C/W
R _{θJB}	Junction-to-board thermal resistance	58.3	°C/W
Ψ _{JT}	Junction-to-top characterization parameter	5.2	°C/W
Ψ _{JB}	Junction-to-board characterization parameter	59.6	°C/W
R _{θJC(bot)}	Junction-to-case (bottom) thermal resistance	N/A	°C/W

- (1) For more information about traditional and new thermal metrics, see the *IC Package Thermal Metrics* application report, [SPRA953](#).

7.4 Recommended Operating Conditions

at specified temperature range (unless otherwise noted)

		MIN	MAX	UNIT
V _{DD}	Supply voltage	1.1	6	V
T _J	Operating junction temperature	-40	125	°C

7.5 Electrical Characteristics

over recommended operating junction temperature range (unless otherwise noted)

PARAMETER		TEST CONDITIONS	MIN	TYP	MAX	UNIT	
V _{OL}	Low-level output voltage	V _{DD} = 2 V to 6 V, I _{OL} = 500 μA			0.2	V	
		V _{DD} = 3.3 V, I _{OL} = 2 mA			0.4		
		V _{DD} = 6 V, I _{OL} = 4 mA			0.4		
Power-up reset voltage ⁽¹⁾		I _{OL} = 50 μA, V _{OL} < 0.2 V	1.1			V	
V _{IT-}	Negative-going input threshold voltage ⁽²⁾	T _J = -40°C to +125°C	TLV803Z	2.20	2.25	2.30	V
			TLV803R	2.58	2.64	2.70	
			TLV803S	2.87	2.93	2.99	
			TLV8x3M	4.28	4.38	4.48	
V _{hys}	Hysteresis	T _J = 25°C, I _{OL} = 50 μA	TLV803Z		30		mV
			TLV803R		35		
			TLV803S		40		
			TLV8x3M		60		
I _{DD}	Supply current	V _{DD} = 2 V, output unconnected		9	15	μA	
		V _{DD} = 6 V, output unconnected		20	30		
I _{OH}	Output leakage current	V _{DD} = 6 V			100	nA	

(1) The lowest supply voltage at which $\overline{\text{RESET}}$ becomes valid. $t_{r,VDD} \leq 66.7$ V/ms.

(2) To ensure best stability of the threshold voltage, place a bypass capacitor (0.1-μF ceramic) near the supply terminals.

7.6 Switching Characteristics

over operating temperature range (unless otherwise noted)

PARAMETER	TEST CONDITIONS	MIN	TYP	MAX	UNIT	
t _w	Pulse duration at V _{DD}	V _{DD} = 1.08 V _{IT-} to 0.92 V _{IT-}	1		μs	
t _d	Delay time	V _{DD} ≥ V _{IT-} + 0.2 V; see Timing Diagram	120	200	280	ms

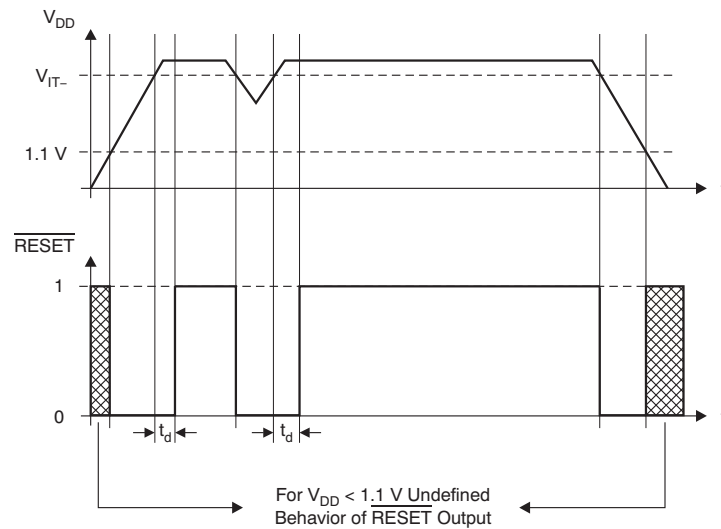
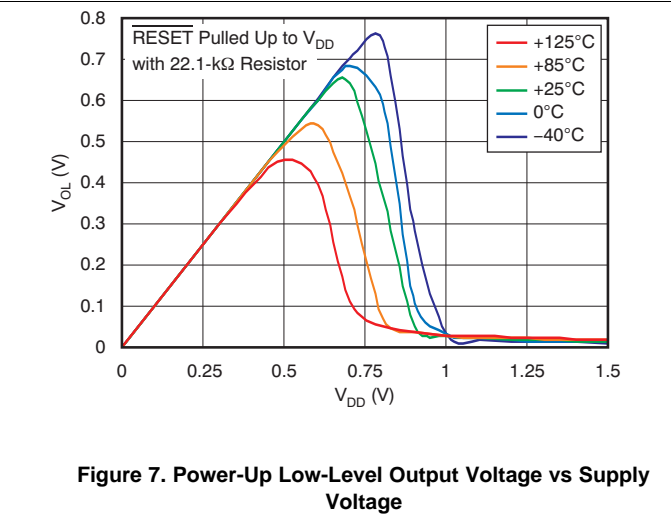
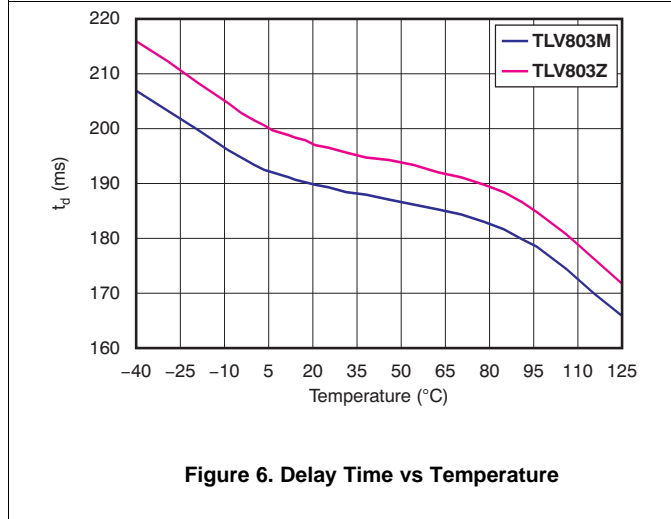
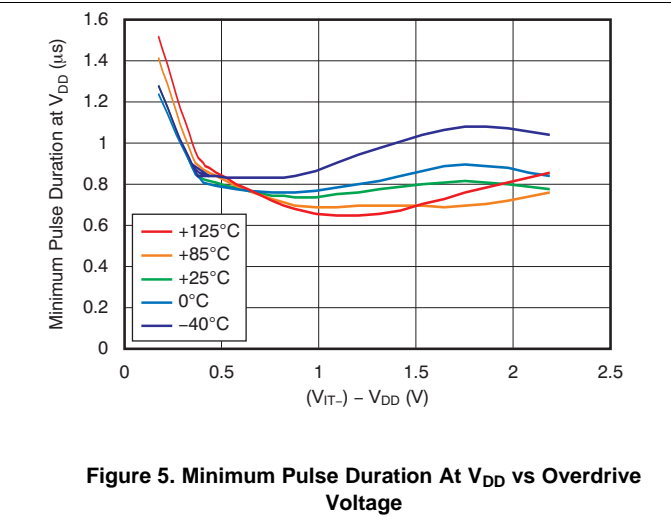
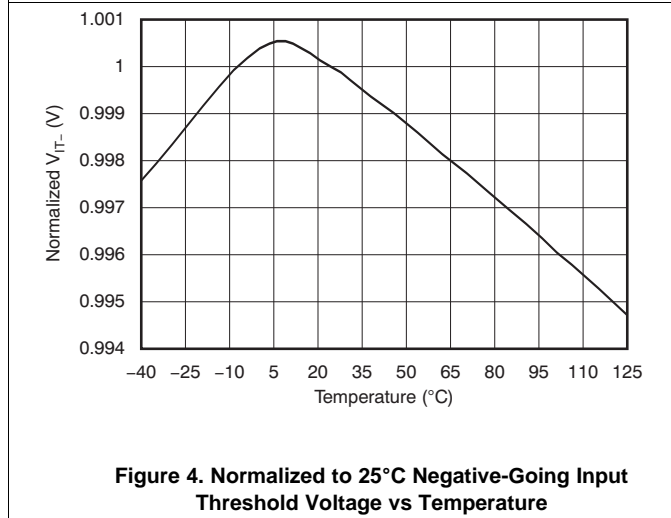
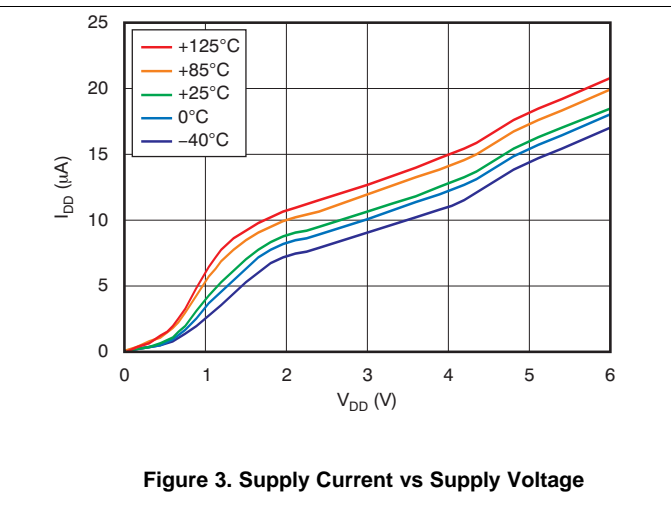
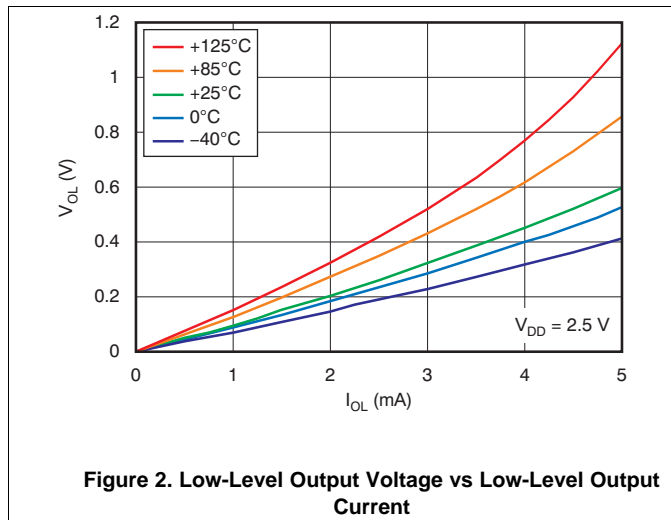

Figure 1. Timing Diagram

7.7 Typical Characteristics

at $T_J = 25^\circ\text{C}$, $V_{IT-} = 4.38\text{ V}$, and $V_{DD} = 5.0\text{ V}$ (unless otherwise noted)



8 Detailed Description

8.1 Overview

The TLV803 family of supervisory circuits provides circuit initialization and timing supervision. The TLV853 and TLV863 are both functionally equivalent to the TLV803. These devices output a logic low whenever V_{DD} drops below the negative-going threshold voltage (V_{IT-}). The output, \overline{RESET} , remains low for approximately 200 ms after the V_{DD} voltage exceeds the positive-going threshold voltage ($V_{IT+} + V_{hys}$). These devices are designed to ignore fast transients on the V_{DD} pin.

8.2 Functional Block Diagram

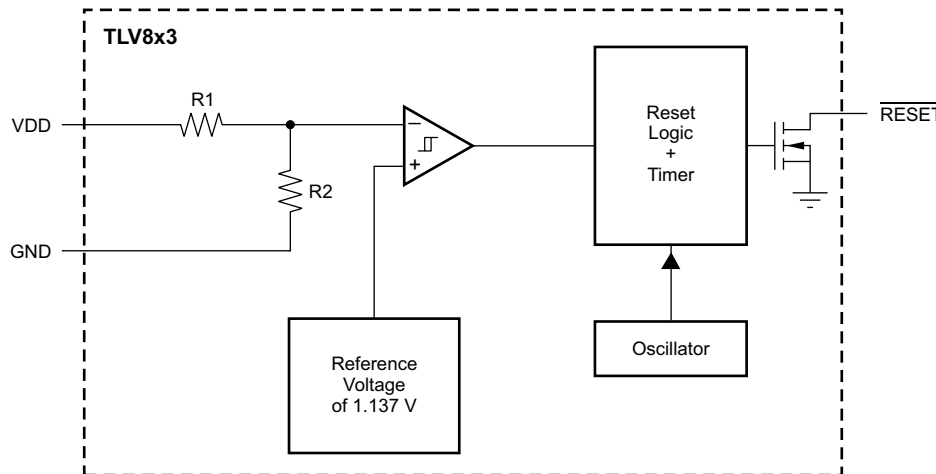

8.3 Feature Description

8.3.1 V_{DD} Transient Rejection

The TLV803 has built-in rejection of fast transients on the V_{DD} pin. The rejection of transients depends on both the duration and the amplitude of the transient. The amplitude of the transient is measured from the bottom of the transient to the negative threshold voltage of the TLV803, as shown in Figure 8.

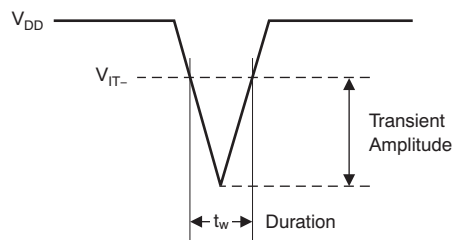

Figure 8. Voltage Transient Measurement

The TLV803 does not respond to transients that are fast duration/low amplitude or long duration/small amplitude. Figure 5 shows the relationship between the transient amplitude and duration needed to trigger a reset. Any combination of duration and amplitude above the curve generates a reset signal.

Feature Description (continued)

8.3.2 Reset During Power Up and Power Down

The TLV803 output is valid when V_{DD} is greater than 1.1 V. When V_{DD} is less than 1.1 V, the output transistor turns off and becomes high impedance. The voltage on the $\overline{\text{RESET}}$ pin rises to the voltage level connected to the pull-up resistor. Figure 9 shows a typical waveform for power-up, assuming the $\overline{\text{RESET}}$ pin has a pull-up resistor connected to the V_{DD} pin.

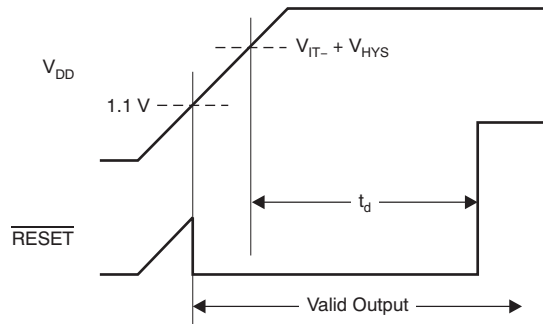

Figure 9. Power-Up Response

8.3.3 Bidirectional Reset Pins

Some microcontrollers have bidirectional reset pins that act as both inputs and outputs. In a situation where the TLV803 is pulling the $\overline{\text{RESET}}$ line low while the microcontroller is trying to force the $\overline{\text{RESET}}$ line high, a series resistor should be placed between the output of the TLV803 and the $\overline{\text{RESET}}$ pin of the microcontroller to protect against excessive current flow. Figure 10 shows the connection of the TLV803 to a microcontroller using a series resistor to drive a bidirectional $\overline{\text{RESET}}$ line.

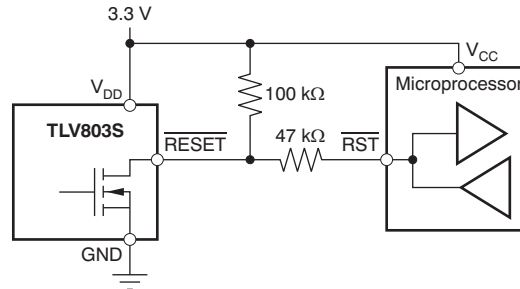

Figure 10. Connection To Bidirectional Reset Pin

8.4 Device Functional Modes

8.4.1 Normal Operation ($V_{DD} >$ Power-Up Reset Voltage)

When the voltage on V_{DD} is greater than 1.1 V, the $\overline{\text{RESET}}$ signal asserts when V_{DD} is less than V_{IT-} and deasserts when V_{DD} is greater than V_{IT-} .

8.4.2 Power On Reset ($V_{DD} <$ Power-Up Reset Voltage)

When the voltage on V_{DD} is lower than the required voltage to internally pull the asserted output to GND (power-up reset voltage), both outputs are in a high-impedance state.

9 Application and Implementation

NOTE

Information in the following applications sections is not part of the TI component specification, and TI does not warrant its accuracy or completeness. TI's customers are responsible for determining suitability of components for their purposes. Customers should validate and test their design implementation to confirm system functionality.

9.1 Application Information

9.1.1 Monitoring Multiple Supplies

Because the TLV803 has an open-drain output, multiple TLV803 outputs can be directly tied together to form a logical OR-ing function for the RESET line. Only one pull-up resistor is required for this configuration. Figure 11 shows two TLV803s connected together to provide monitoring of a 3.3-V power rail and a 5.0-V power rail. A reset is generated if either power rail falls below the threshold voltage of its corresponding TLV803.

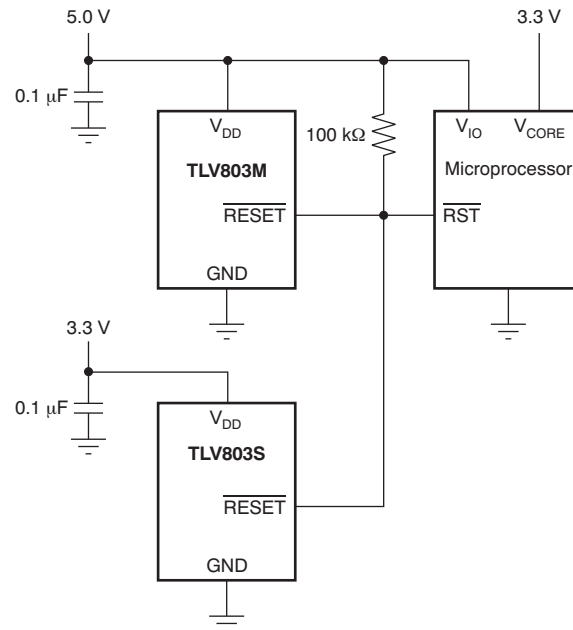

Figure 11. Multiple Voltage Rail Monitoring

9.1.2 Output Level Shifting

The $\overline{\text{RESET}}$ output of the TLV803 can be pulled to a maximum voltage of 6 V and can be pulled higher in voltage than V_{DD} . It is useful to provide level shifting of the output for cases where the monitored voltage is less than the useful logic levels of the load. Figure 12 shows the TLV803Z used to monitor a 2.5-V power rail, with a logic RESET input to a microprocessor that is connected to 5.0 V and has 5.0-V logic levels.

Application Information (continued)

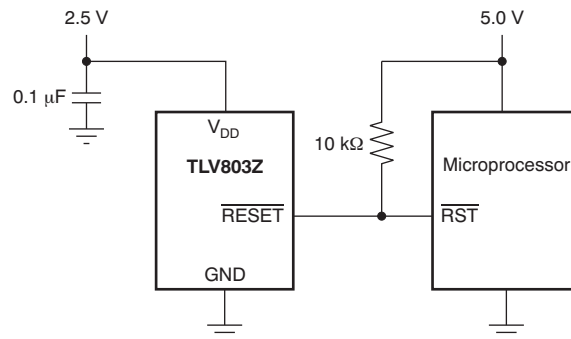

Figure 12. Output Voltage Level Shifting

9.2 Typical Application

Figure 13 shows TLV803S being used to monitor the supply rail for a DSP, FPGA, or ASIC.

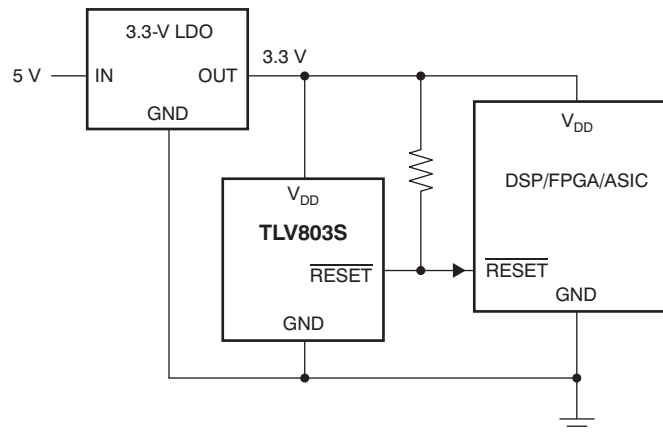

Figure 13. Typical Application

9.2.1 Design Requirements

This design calls for a 3.3-V rail to be monitored. The design resets if the supply rail falls below 2.93 V. The output must satisfy 3.3-V CMOS logic.

9.2.2 Detailed Design Procedure

Select the TLV803S to satisfy the voltage threshold requirement.

Place a pullup resistor on $\overline{\text{RESET}}$ to VDD in order to satisfy the output logic requirement.

Typical Application (continued)

9.2.3 Application Curves

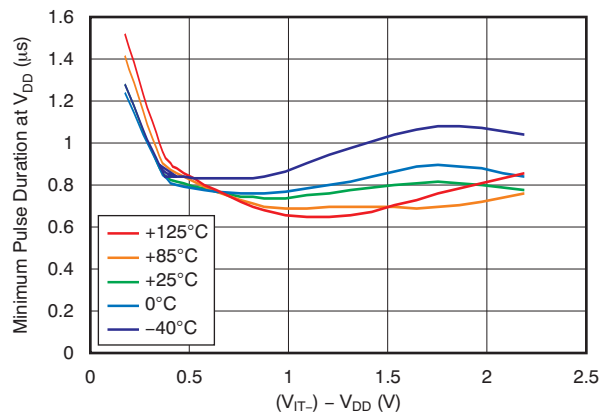

Figure 14. Minimum Pulse Duration At V_{DD} vs Overdrive Threshold Voltage vs Temperature Voltage

10 Power Supply Recommendations

These devices are designed to operate from an input voltage supply range between 1.1 V and 6 V.

11 Layout

11.1 Layout Guidelines

Place the C_{IN} decoupling capacitor close to the device.

11.2 Layout Example

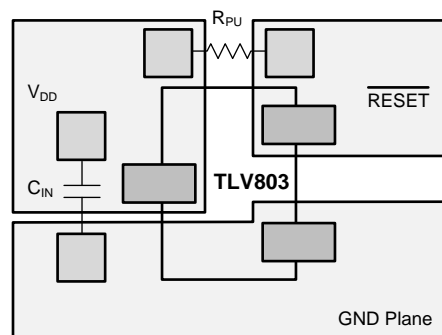

Figure 15. Layout Example (DBZ Package)

12 Device and Documentation Support

12.1 Device Support

12.1.1 Development Support

12.1.1.1 Evaluation Modules

An evaluation module (EVM) is available to assist in the initial circuit performance evaluation using the TLV803. The [TLV803SEVM-019 evaluation module](#) (and [related user guide](#)) can be requested at the Texas Instruments website through the product folders or purchased directly [from the TI eStore](#).

12.1.1.2 Spice Models

Computer simulation of circuit performance using SPICE is often useful when analyzing the performance of analog circuits and systems. SPICE models for the TLV803, TLV853, and TLV863 are available through the respective device product folders under *Tools & Software*.

12.2 Documentation Support

12.2.1 Related Documentation

- TLV803SEVM-019 User's Guide. Literature number [SLVU461](#).

12.3 Related Links

[Table 3](#) lists quick access links. Categories include technical documents, support and community resources, tools and software, and quick access to sample or buy.

Table 3. Related Links

PARTS	PRODUCT FOLDER	SAMPLE & BUY	TECHNICAL DOCUMENTS	TOOLS & SOFTWARE	SUPPORT & COMMUNITY
TLV803	Click here	Click here	Click here	Click here	Click here
TLV853	Click here	Click here	Click here	Click here	Click here
TLV863	Click here	Click here	Click here	Click here	Click here

12.4 Community Resources

The following links connect to TI community resources. Linked contents are provided "AS IS" by the respective contributors. They do not constitute TI specifications and do not necessarily reflect TI's views; see TI's [Terms of Use](#).

TI E2E™ Online Community *TI's Engineer-to-Engineer (E2E) Community*. Created to foster collaboration among engineers. At e2e.ti.com, you can ask questions, share knowledge, explore ideas and help solve problems with fellow engineers.

Design Support *TI's Design Support* Quickly find helpful E2E forums along with design support tools and contact information for technical support.

12.5 Trademarks

E2E is a trademark of Texas Instruments.
All other trademarks are the property of their respective owners.

12.6 Electrostatic Discharge Caution



This integrated circuit can be damaged by ESD. Texas Instruments recommends that all integrated circuits be handled with appropriate precautions. Failure to observe proper handling and installation procedures can cause damage.

ESD damage can range from subtle performance degradation to complete device failure. Precision integrated circuits may be more susceptible to damage because very small parametric changes could cause the device not to meet its published specifications.

12.7 Glossary

[SLYZ022](#) — *TI Glossary*.

This glossary lists and explains terms, acronyms, and definitions.

13 Mechanical, Packaging, and Orderable Information

The following pages include mechanical, packaging, and orderable information. This information is the most current data available for the designated devices. This data is subject to change without notice and revision of this document. For browser-based versions of this data sheet, refer to the left-hand navigation.

PACKAGING INFORMATION

Orderable Device	Status (1)	Package Type	Package Drawing	Pins	Package Qty	Eco Plan (2)	Lead/Ball Finish (6)	MSL Peak Temp (3)	Op Temp (°C)	Device Marking (4/5)	Samples
TLV803MDBZR	ACTIVE	SOT-23	DBZ	3	3000	Green (RoHS & no Sb/Br)	CU NIPDAU	Level-1-260C-UNLIM	-40 to 125	VOUQ	Samples
TLV803MDBZT	ACTIVE	SOT-23	DBZ	3	250	Green (RoHS & no Sb/Br)	CU NIPDAU	Level-1-260C-UNLIM	-40 to 125	VOUQ	Samples
TLV803RDBZR	ACTIVE	SOT-23	DBZ	3	3000	Green (RoHS & no Sb/Br)	CU NIPDAU	Level-1-260C-UNLIM	-40 to 125	VOSQ	Samples
TLV803RDBZT	ACTIVE	SOT-23	DBZ	3	250	Green (RoHS & no Sb/Br)	CU NIPDAU	Level-1-260C-UNLIM	-40 to 125	VOSQ	Samples
TLV803SDBZR	ACTIVE	SOT-23	DBZ	3	3000	Green (RoHS & no Sb/Br)	CU NIPDAU	Level-1-260C-UNLIM	-40 to 125	VOTQ	Samples
TLV803SDBZT	ACTIVE	SOT-23	DBZ	3	250	Green (RoHS & no Sb/Br)	CU NIPDAU	Level-1-260C-UNLIM	-40 to 125	VOTQ	Samples
TLV803ZDBZR	ACTIVE	SOT-23	DBZ	3	3000	Green (RoHS & no Sb/Br)	CU NIPDAU	Level-1-260C-UNLIM	-40 to 125	VORQ	Samples
TLV803ZDBZT	ACTIVE	SOT-23	DBZ	3	250	Green (RoHS & no Sb/Br)	CU NIPDAU	Level-1-260C-UNLIM	-40 to 125	VORQ	Samples
TLV853MDBZR	ACTIVE	SOT-23	DBZ	3	3000	Green (RoHS & no Sb/Br)	CU NIPDAU	Level-1-260C-UNLIM	-40 to 125	ZGM4	Samples
TLV853MDBZT	ACTIVE	SOT-23	DBZ	3	250	Green (RoHS & no Sb/Br)	CU NIPDAU	Level-1-260C-UNLIM	-40 to 125	ZGM4	Samples
TLV863MDBZR	ACTIVE	SOT-23	DBZ	3	3000	Green (RoHS & no Sb/Br)	CU NIPDAU	Level-1-260C-UNLIM	-40 to 125	VTWM	Samples
TLV863MDBZT	ACTIVE	SOT-23	DBZ	3	250	Green (RoHS & no Sb/Br)	CU NIPDAU	Level-1-260C-UNLIM	-40 to 125	VTWM	Samples

(1) The marketing status values are defined as follows:

ACTIVE: Product device recommended for new designs.

LIFEBUY: TI has announced that the device will be discontinued, and a lifetime-buy period is in effect.

NRND: Not recommended for new designs. Device is in production to support existing customers, but TI does not recommend using this part in a new design.

PREVIEW: Device has been announced but is not in production. Samples may or may not be available.

OBSELETE: TI has discontinued the production of the device.

(2) **RoHS:** TI defines "RoHS" to mean semiconductor products that are compliant with the current EU RoHS requirements for all 10 RoHS substances, including the requirement that RoHS substance do not exceed 0.1% by weight in homogeneous materials. Where designed to be soldered at high temperatures, "RoHS" products are suitable for use in specified lead-free processes. TI may reference these types of products as "Pb-Free".

RoHS Exempt: TI defines "RoHS Exempt" to mean products that contain lead but are compliant with EU RoHS pursuant to a specific EU RoHS exemption.

Green: TI defines "Green" to mean the content of Chlorine (Cl) and Bromine (Br) based flame retardants meet JS709B low halogen requirements of ≤ 1000 ppm threshold. Antimony trioxide based flame retardants must also meet the ≤ 1000 ppm threshold requirement.

(3) MSL, Peak Temp. - The Moisture Sensitivity Level rating according to the JEDEC industry standard classifications, and peak solder temperature.

(4) There may be additional marking, which relates to the logo, the lot trace code information, or the environmental category on the device.

(5) Multiple Device Markings will be inside parentheses. Only one Device Marking contained in parentheses and separated by a "~" will appear on a device. If a line is indented then it is a continuation of the previous line and the two combined represent the entire Device Marking for that device.

(6) Lead/Ball Finish - Orderable Devices may have multiple material finish options. Finish options are separated by a vertical ruled line. Lead/Ball Finish values may wrap to two lines if the finish value exceeds the maximum column width.

Important Information and Disclaimer: The information provided on this page represents TI's knowledge and belief as of the date that it is provided. TI bases its knowledge and belief on information provided by third parties, and makes no representation or warranty as to the accuracy of such information. Efforts are underway to better integrate information from third parties. TI has taken and continues to take reasonable steps to provide representative and accurate information but may not have conducted destructive testing or chemical analysis on incoming materials and chemicals. TI and TI suppliers consider certain information to be proprietary, and thus CAS numbers and other limited information may not be available for release.

In no event shall TI's liability arising out of such information exceed the total purchase price of the TI part(s) at issue in this document sold by TI to Customer on an annual basis.

TAPE AND REEL INFORMATION

QUADRANT ASSIGNMENTS FOR PIN 1 ORIENTATION IN TAPE

*All dimensions are nominal

Device	Package Type	Package Drawing	Pins	SPQ	Reel Diameter (mm)	Reel Width W1 (mm)	A0 (mm)	B0 (mm)	K0 (mm)	P1 (mm)	W (mm)	Pin1 Quadrant
TLV803MDBZR	SOT-23	DBZ	3	3000	179.0	8.4	3.15	2.95	1.22	4.0	8.0	Q3
TLV803MDBZT	SOT-23	DBZ	3	250	179.0	8.4	3.15	2.95	1.22	4.0	8.0	Q3
TLV803RDBZR	SOT-23	DBZ	3	3000	179.0	8.4	3.15	2.95	1.22	4.0	8.0	Q3
TLV803RDBZT	SOT-23	DBZ	3	250	179.0	8.4	3.15	2.95	1.22	4.0	8.0	Q3
TLV803SDBZR	SOT-23	DBZ	3	3000	179.0	8.4	3.15	2.95	1.22	4.0	8.0	Q3
TLV803SDBZT	SOT-23	DBZ	3	250	179.0	8.4	3.15	2.95	1.22	4.0	8.0	Q3
TLV803ZDBZR	SOT-23	DBZ	3	3000	179.0	8.4	3.15	2.95	1.22	4.0	8.0	Q3
TLV803ZDBZT	SOT-23	DBZ	3	250	179.0	8.4	3.15	2.95	1.22	4.0	8.0	Q3
TLV853MDBZR	SOT-23	DBZ	3	3000	179.0	8.4	3.15	2.95	1.22	4.0	8.0	Q3
TLV853MDBZT	SOT-23	DBZ	3	250	179.0	8.4	3.15	2.95	1.22	4.0	8.0	Q3
TLV863MDBZR	SOT-23	DBZ	3	3000	179.0	8.4	3.15	2.95	1.22	4.0	8.0	Q3
TLV863MDBZT	SOT-23	DBZ	3	250	179.0	8.4	3.15	2.95	1.22	4.0	8.0	Q3

TAPE AND REEL BOX DIMENSIONS

*All dimensions are nominal

Device	Package Type	Package Drawing	Pins	SPQ	Length (mm)	Width (mm)	Height (mm)
TLV803MDBZR	SOT-23	DBZ	3	3000	203.0	203.0	35.0
TLV803MDBZT	SOT-23	DBZ	3	250	203.0	203.0	35.0
TLV803RDBZR	SOT-23	DBZ	3	3000	203.0	203.0	35.0
TLV803RDBZT	SOT-23	DBZ	3	250	203.0	203.0	35.0
TLV803SDBZR	SOT-23	DBZ	3	3000	203.0	203.0	35.0
TLV803SDBZT	SOT-23	DBZ	3	250	203.0	203.0	35.0
TLV803ZDBZR	SOT-23	DBZ	3	3000	203.0	203.0	35.0
TLV803ZDBZT	SOT-23	DBZ	3	250	203.0	203.0	35.0
TLV853MDBZR	SOT-23	DBZ	3	3000	203.0	203.0	35.0
TLV853MDBZT	SOT-23	DBZ	3	250	203.0	203.0	35.0
TLV863MDBZR	SOT-23	DBZ	3	3000	203.0	203.0	35.0
TLV863MDBZT	SOT-23	DBZ	3	250	203.0	203.0	35.0

GENERIC PACKAGE VIEW

DBZ 3

SOT-23 - 1.12 mm max height

SMALL OUTLINE TRANSISTOR

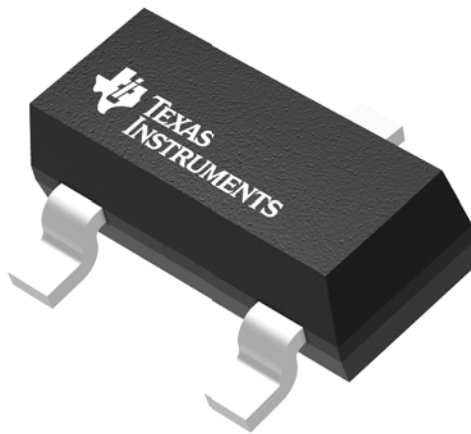

Images above are just a representation of the package family, actual package may vary.
Refer to the product data sheet for package details.

4203227/C

DBZ0003A



PACKAGE OUTLINE

SOT-23 - 1.12 mm max height

SMALL OUTLINE TRANSISTOR

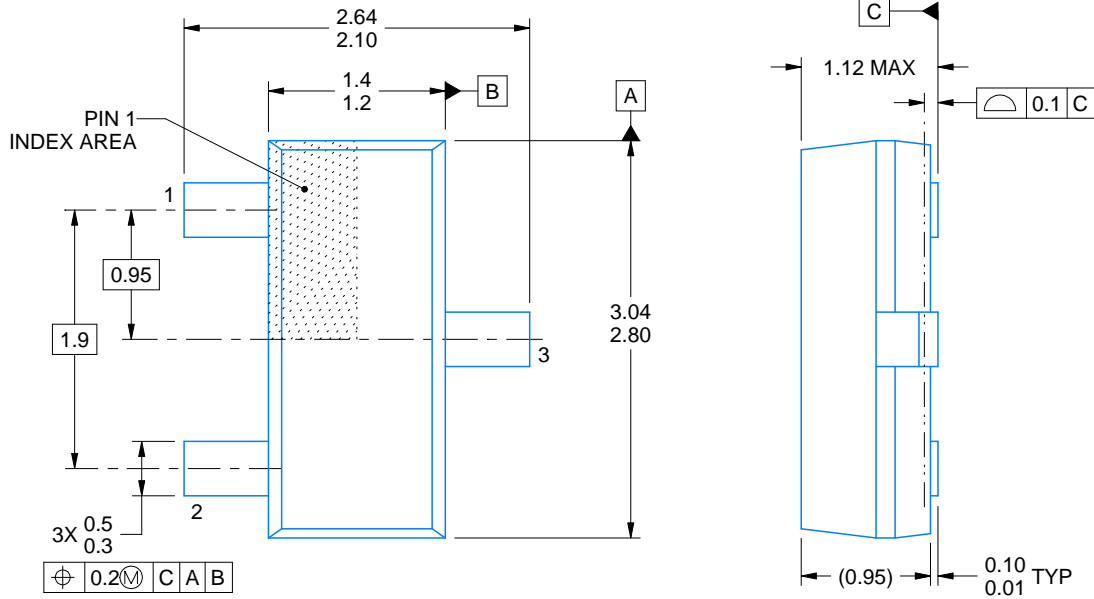

4214838/C 04/2017

NOTES:

1. All linear dimensions are in millimeters. Any dimensions in parenthesis are for reference only. Dimensioning and tolerancing per ASME Y14.5M.
2. This drawing is subject to change without notice.
3. Reference JEDEC registration TO-236, except minimum foot length.

EXAMPLE BOARD LAYOUT

DBZ0003A

SOT-23 - 1.12 mm max height

SMALL OUTLINE TRANSISTOR

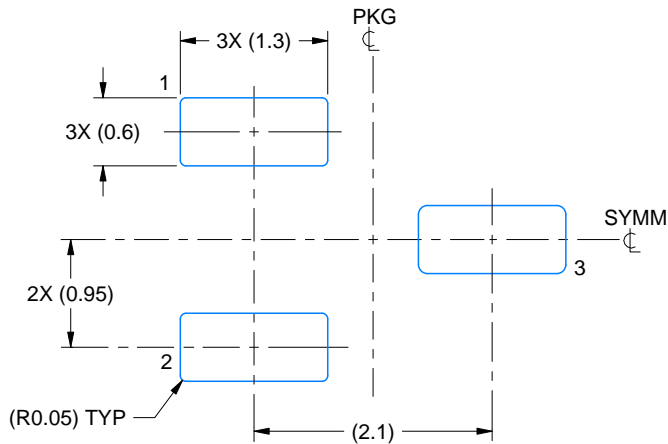

LAND PATTERN EXAMPLE
SCALE:15X

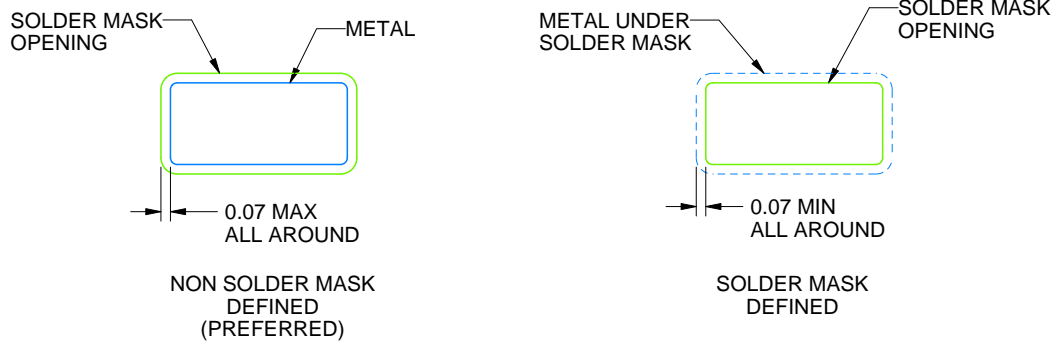

SOLDER MASK DETAILS

4214838/C 04/2017

NOTES: (continued)

4. Publication IPC-7351 may have alternate designs.
5. Solder mask tolerances between and around signal pads can vary based on board fabrication site.

EXAMPLE STENCIL DESIGN

DBZ0003A

SOT-23 - 1.12 mm max height

SMALL OUTLINE TRANSISTOR

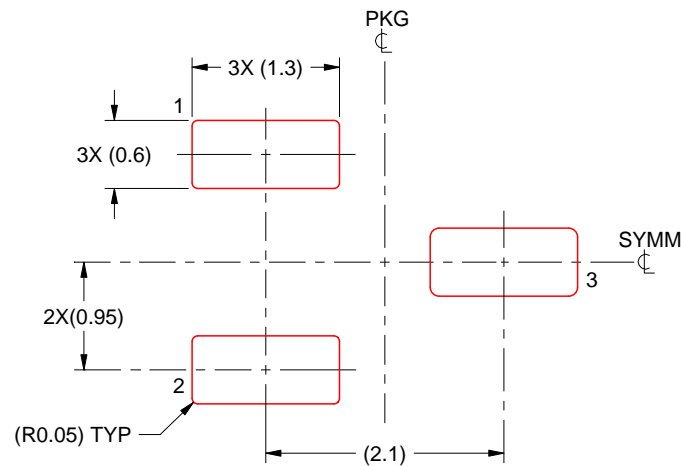

SOLDER PASTE EXAMPLE
BASED ON 0.125 THICK STENCIL
SCALE:15X

4214838/C 04/2017

NOTES: (continued)

6. Laser cutting apertures with trapezoidal walls and rounded corners may offer better paste release. IPC-7525 may have alternate design recommendations.
7. Board assembly site may have different recommendations for stencil design.

IMPORTANT NOTICE

Texas Instruments Incorporated (TI) reserves the right to make corrections, enhancements, improvements and other changes to its semiconductor products and services per JESD46, latest issue, and to discontinue any product or service per JESD48, latest issue. Buyers should obtain the latest relevant information before placing orders and should verify that such information is current and complete.

TI's published terms of sale for semiconductor products (<http://www.ti.com/sc/docs/stdterms.htm>) apply to the sale of packaged integrated circuit products that TI has qualified and released to market. Additional terms may apply to the use or sale of other types of TI products and services.

Reproduction of significant portions of TI information in TI data sheets is permissible only if reproduction is without alteration and is accompanied by all associated warranties, conditions, limitations, and notices. TI is not responsible or liable for such reproduced documentation. Information of third parties may be subject to additional restrictions. Resale of TI products or services with statements different from or beyond the parameters stated by TI for that product or service voids all express and any implied warranties for the associated TI product or service and is an unfair and deceptive business practice. TI is not responsible or liable for any such statements.

Buyers and others who are developing systems that incorporate TI products (collectively, "Designers") understand and agree that Designers remain responsible for using their independent analysis, evaluation and judgment in designing their applications and that Designers have full and exclusive responsibility to assure the safety of Designers' applications and compliance of their applications (and of all TI products used in or for Designers' applications) with all applicable regulations, laws and other applicable requirements. Designer represents that, with respect to their applications, Designer has all the necessary expertise to create and implement safeguards that (1) anticipate dangerous consequences of failures, (2) monitor failures and their consequences, and (3) lessen the likelihood of failures that might cause harm and take appropriate actions. Designer agrees that prior to using or distributing any applications that include TI products, Designer will thoroughly test such applications and the functionality of such TI products as used in such applications.

TI's provision of technical, application or other design advice, quality characterization, reliability data or other services or information, including, but not limited to, reference designs and materials relating to evaluation modules, (collectively, "TI Resources") are intended to assist designers who are developing applications that incorporate TI products; by downloading, accessing or using TI Resources in any way, Designer (individually or, if Designer is acting on behalf of a company, Designer's company) agrees to use any particular TI Resource solely for this purpose and subject to the terms of this Notice.

TI's provision of TI Resources does not expand or otherwise alter TI's applicable published warranties or warranty disclaimers for TI products, and no additional obligations or liabilities arise from TI providing such TI Resources. TI reserves the right to make corrections, enhancements, improvements and other changes to its TI Resources. TI has not conducted any testing other than that specifically described in the published documentation for a particular TI Resource.

Designer is authorized to use, copy and modify any individual TI Resource only in connection with the development of applications that include the TI product(s) identified in such TI Resource. NO OTHER LICENSE, EXPRESS OR IMPLIED, BY ESTOPPEL OR OTHERWISE TO ANY OTHER TI INTELLECTUAL PROPERTY RIGHT, AND NO LICENSE TO ANY TECHNOLOGY OR INTELLECTUAL PROPERTY RIGHT OF TI OR ANY THIRD PARTY IS GRANTED HEREIN, including but not limited to any patent right, copyright, mask work right, or other intellectual property right relating to any combination, machine, or process in which TI products or services are used. Information regarding or referencing third-party products or services does not constitute a license to use such products or services, or a warranty or endorsement thereof. Use of TI Resources may require a license from a third party under the patents or other intellectual property of the third party, or a license from TI under the patents or other intellectual property of TI.

TI RESOURCES ARE PROVIDED "AS IS" AND WITH ALL FAULTS. TI DISCLAIMS ALL OTHER WARRANTIES OR REPRESENTATIONS, EXPRESS OR IMPLIED, REGARDING RESOURCES OR USE THEREOF, INCLUDING BUT NOT LIMITED TO ACCURACY OR COMPLETENESS, TITLE, ANY EPIDEMIC FAILURE WARRANTY AND ANY IMPLIED WARRANTIES OF MERCHANTABILITY, FITNESS FOR A PARTICULAR PURPOSE, AND NON-INFRINGEMENT OF ANY THIRD PARTY INTELLECTUAL PROPERTY RIGHTS. TI SHALL NOT BE LIABLE FOR AND SHALL NOT DEFEND OR INDEMNIFY DESIGNER AGAINST ANY CLAIM, INCLUDING BUT NOT LIMITED TO ANY INFRINGEMENT CLAIM THAT RELATES TO OR IS BASED ON ANY COMBINATION OF PRODUCTS EVEN IF DESCRIBED IN TI RESOURCES OR OTHERWISE. IN NO EVENT SHALL TI BE LIABLE FOR ANY ACTUAL, DIRECT, SPECIAL, COLLATERAL, INDIRECT, PUNITIVE, INCIDENTAL, CONSEQUENTIAL OR EXEMPLARY DAMAGES IN CONNECTION WITH OR ARISING OUT OF TI RESOURCES OR USE THEREOF, AND REGARDLESS OF WHETHER TI HAS BEEN ADVISED OF THE POSSIBILITY OF SUCH DAMAGES.

Unless TI has explicitly designated an individual product as meeting the requirements of a particular industry standard (e.g., ISO/TS 16949 and ISO 26262), TI is not responsible for any failure to meet such industry standard requirements.

Where TI specifically promotes products as facilitating functional safety or as compliant with industry functional safety standards, such products are intended to help enable customers to design and create their own applications that meet applicable functional safety standards and requirements. Using products in an application does not by itself establish any safety features in the application. Designers must ensure compliance with safety-related requirements and standards applicable to their applications. Designer may not use any TI products in life-critical medical equipment unless authorized officers of the parties have executed a special contract specifically governing such use. Life-critical medical equipment is medical equipment where failure of such equipment would cause serious bodily injury or death (e.g., life support, pacemakers, defibrillators, heart pumps, neurostimulators, and implantables). Such equipment includes, without limitation, all medical devices identified by the U.S. Food and Drug Administration as Class III devices and equivalent classifications outside the U.S.

TI may expressly designate certain products as completing a particular qualification (e.g., Q100, Military Grade, or Enhanced Product). Designers agree that it has the necessary expertise to select the product with the appropriate qualification designation for their applications and that proper product selection is at Designers' own risk. Designers are solely responsible for compliance with all legal and regulatory requirements in connection with such selection.

Designer will fully indemnify TI and its representatives against any damages, costs, losses, and/or liabilities arising out of Designer's non-compliance with the terms and provisions of this Notice.