

Unit in mm

Telecommunication

Data Acquisition

Measurement Instrumentation

The Toshiba TLP595G consists of an aluminum gallium arsenide infrared emitting diode optically coupled to a photo-MOSFET in a six lead plastic DIP package. The TLP595G is a bi-directional switch which can replace mechanical relays in many applications.

- Peak Off-State Voltage : 400V (Min.)
- On-State Current : 150mA (Max.) (A Connection)
- On-State Resistance : 12Ω (Max.) (A Connection)
- Isolation Voltage : 2500Vrms (Min.)
- UL Recognized : UL1577, File No. E67349
- Trigger LED Current (Ta = 25°C)

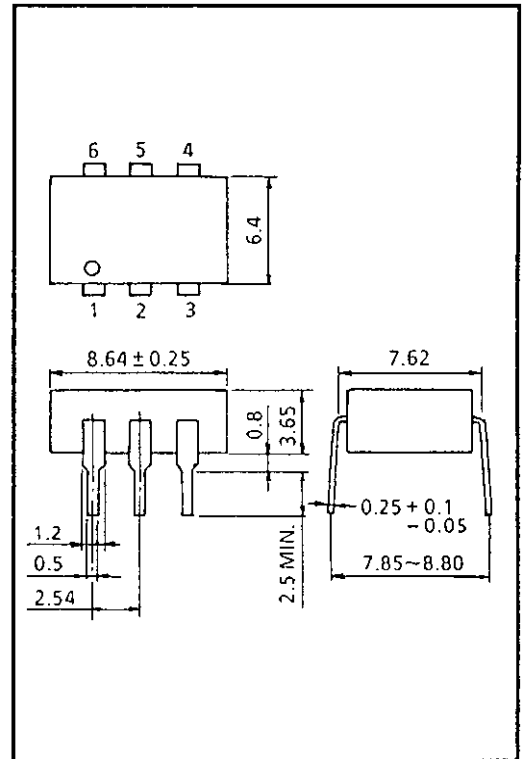

Supplementary Information	Page (s)
Lead Form Options	31-32
Tape and Reel	39-40

JEDEC	—
EIAJ	—
TOSHIBA	11-9A1

Weight : 0.49g

Pin Configuration (Top View)

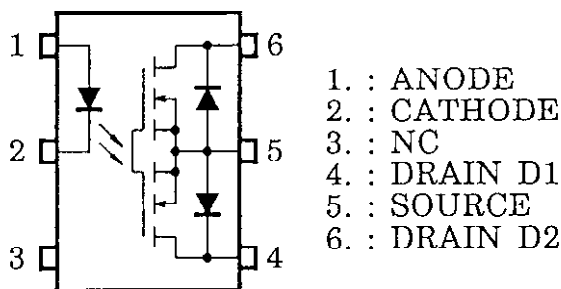

Schematic

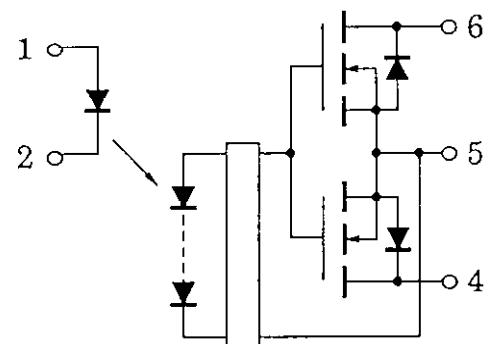

The information contained here is subject to change without notice.

The information contained herein is presented only as guide for the applications of our products. No responsibility is assumed by TOSHIBA for any infringements of patents or other rights of the third parties which may result from its use. No license is granted by implication or otherwise under any patent or patent rights of TOSHIBA or others. These TOSHIBA products are intended for usage in general electronic equipments (office equipment, communication equipment, measuring equipment, domestic electrification, etc.) Please make sure that you consult with us before you use these TOSHIBA products in equipments which require high quality and/or reliability, and in equipments which could have major impact to the welfare of human life (atomic energy control, spaceship, traffic signal, combustion control, all types of safety devices, etc.). TOSHIBA cannot accept liability to any damage which may occur in case these TOSHIBA products were used in the mentioned equipments without prior consultation with TOSHIBA.

CLASSIFICATION (Note 1)	TRIGGER LED CURRENT (mA)		MARKING OF CLASSIFICATION
	@ $I_{ON} = 150\text{mA}$		
	MIN.	MAX.	
(IFT2)	–	2	T2
Standard	–	5	T2, Blank

Note 1: Application type name for certification test, please use standard product type name, i.e., TLP595G (IFT2): TLP595G

Maximum Ratings (Ta = 25°C)

CHARACTERISTIC		SYMBOL	RATING	UNIT	
LED	Forward Current	I_F	30	mA	
	Forward Current Derating (Ta ≥ 25°C)	$\Delta I_F / ^\circ\text{C}$	-0.3	mA/°C	
	Peak Forward Current (100µs pulse, 100pps)	I_{FP}	1	A	
	Reverse Voltage	V_R	5	V	
	Junction Temperature	T_j	125	°C	
DETECTOR	Off-State Output Terminal Voltage	V_{OFF}	400	V	
	On-State RMS Current	A Connection	150	mA	
		B Connection	200		
		C Connection	300		
	On-State Current Derating (Ta ≥ 25°C)	A Connection	$\Delta I_{ON} / ^\circ\text{C}$	-1.5	mA/°C
		B Connection	-2.0		
		C Connection	-3.0		
Junction Temperature	t_j	125	°C		
Storage Temperature Range		T_{stg}	-55~100	°C	
Operating Temperature Range		T_{opr}	-20~85	°C	
Lead Soldering Temperature (10s)		T_{sol}	260	°C	
Isolation Voltage (AC, 1 min., R.H. ≤ 60%) (Note 2)		BV_S	2500	V_{rms}	

Note 1: Device considered a two terminal device: pins 1, 2 and 3 shorted together, and pins 4, 5 and 8 shorted together.

Recommended Operating Conditions

CHARACTERISTIC	SYMBOL	MIN.	TYP.	MX.	UNIT
Supply Voltage	V_D	–	–	320	V
Forward Current	I_F	10	15	20	mA
On-State Current	I_{ON}	–	–	150	mA
Operating Temperature	T_{opr}	-20	–	80	°C

Circuit Connections

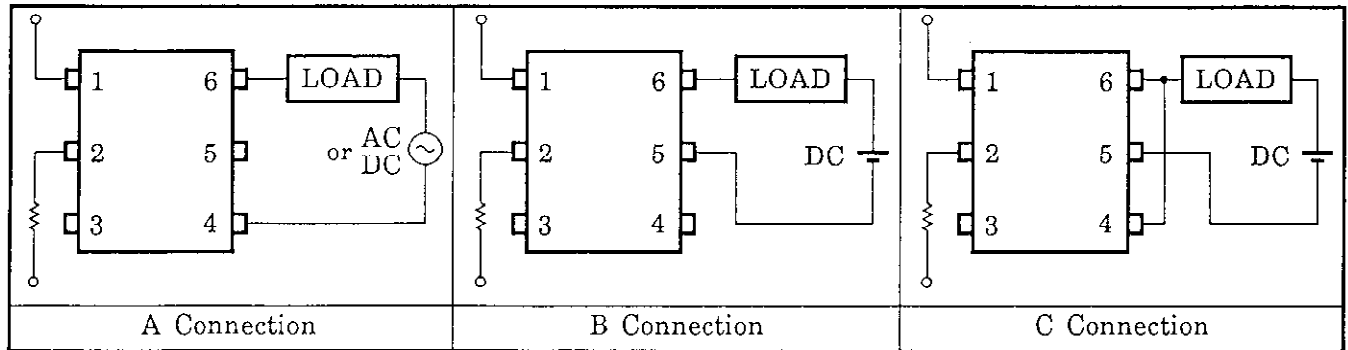

Individual Electrical Characteristics (Ta = -25°C)

CHARACTERISTIC		SYMBOL	TEST CONDITION	MIN.	TYP.*	MX.	UNIT
LED	Forward Voltage	V_F	$I_F = 10\text{mA}$	1.2	1.4	1.7	V
	Reverse Current	I_R	$V_R = 3\text{V}$	–	–	10	μA
	Capacitance	C_T	$V = 0, f = 1\text{MHz}$	–	15	–	pF
DETECTOR	Off-State Current	I_{OFF}	$V_{OFF} = 400\text{V}$	–	–	1	μA
	Capacitance	C_{OFF}	$V = 0, f = 1\text{MHz}$	–	–	–	pF

Coupled Electrical Characteristics (Ta = 25°C)

CHARACTERISTIC		SYMBOL	TEST CONDITION	MIN.	TYP.	MX.	UNIT
Trigger LED Current		I_{FT}	$I_{ON} = 150\text{mA}$	–	1	5	mA
On-State Resistance	A Connection	R_{ON}	$I_{ON} = 150\text{mA}, I_F = 10\text{mA}$	–	8	12	Ω
	B Connection		$I_{ON} = 200\text{mA}, I_F = 10\text{mA}$	–	4	6	
	C Connection		$I_{ON} = 300\text{mA}, I_F = 10\text{mA}$	–	2	3	

Isolation Characteristics (Ta = 25°C)

CHARACTERISTIC	SYMBOL	TEST CONDITION	MIN.	TYP.	MX.	UNIT
Capacitance Input to Output	C_S	$V_S = 0, f = 1\text{MHz}$	–	0.8	–	pF
Isolation Resistance	R_S	$V_S = 500\text{V}, \text{R.H.} \leq 60\%$	5×10^{10}	10^{14}	–	Ω
Isolation Voltage	BV_S	AC, 1 minute	2500	–	–	V_{rms}
		AC, 1 second in oil	–	5000	–	
		DC, 1 minute in oil	–	5000	–	V_{dc}

Switching Characteristics (Ta = 25°C)

CHARACTERISTIC	SYMBOL	TEST CONDITION	MIN.	TYP.	MX.	UNIT
Turn-on Time	t_{on}	$V_{\text{DD}} = 20\text{mA}, R_L = 200\Omega$ $I_F = 10\text{mA}$ (Note 3)	–	0.3	1.0	ms
Turn-off Time	t_{off}		–	0.2	1.0	

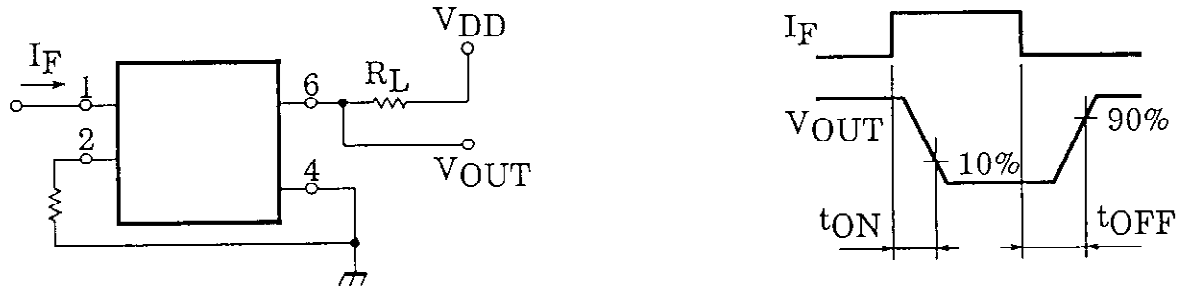
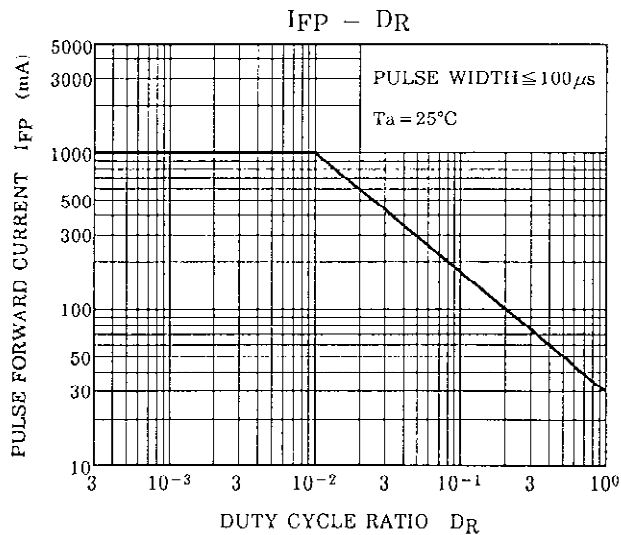
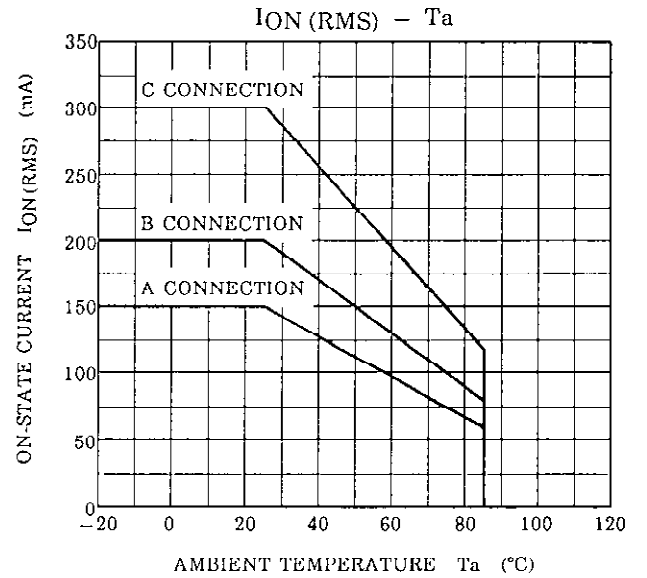
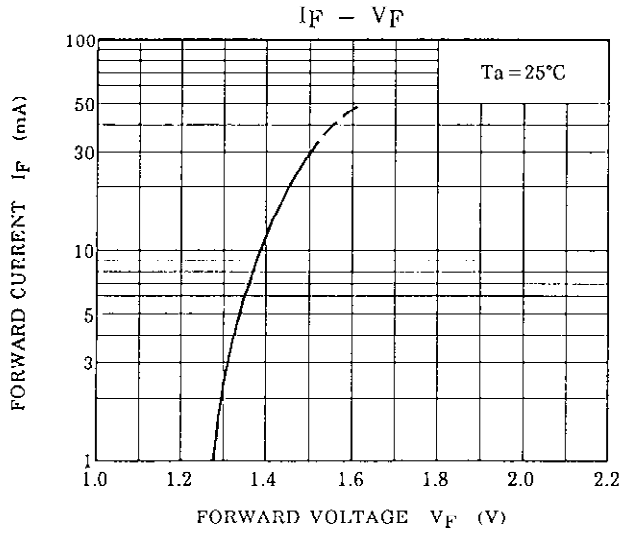
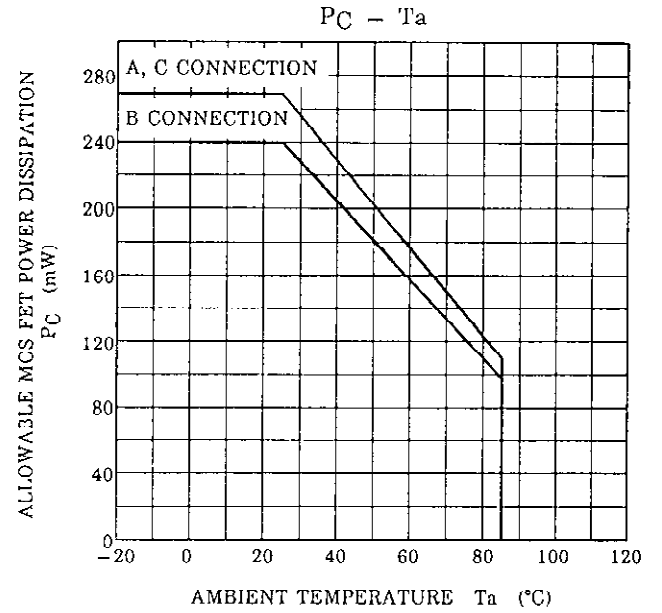
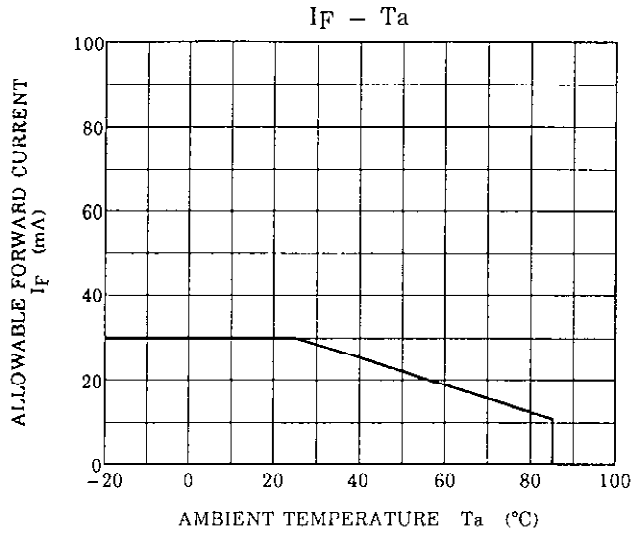
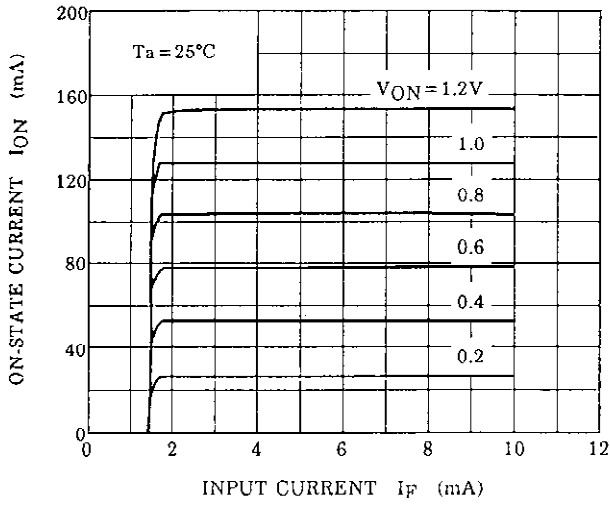

Figure 1. Switching Time Test Circuit



$I_{ON} - I_F$ (A CONNECTION)



$t_{ON} - I_F$

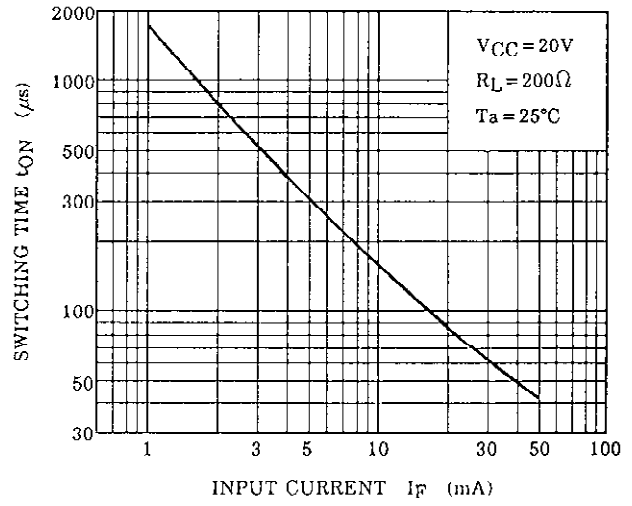

$V_{ON} - I_F$ (A CONNECTION)

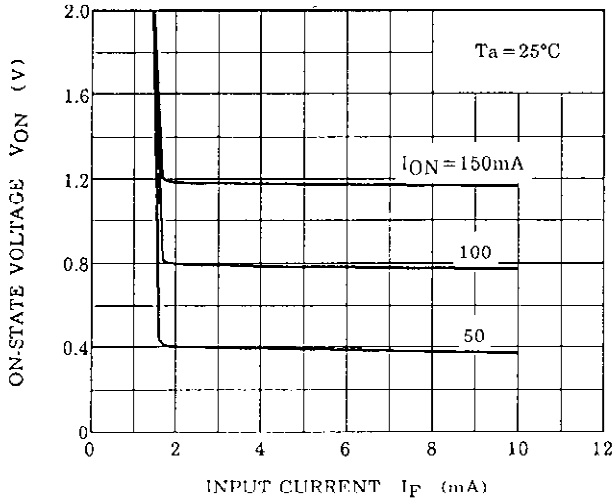

$t_{OFF} - I_F$

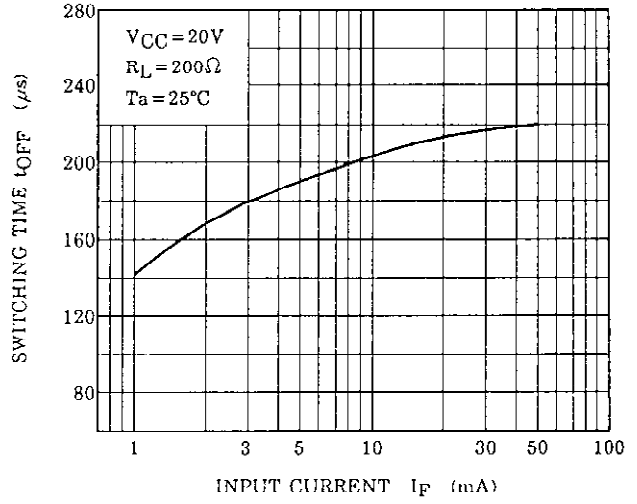

$I_{ON} - V_{ON}$ (A CONNECTION)

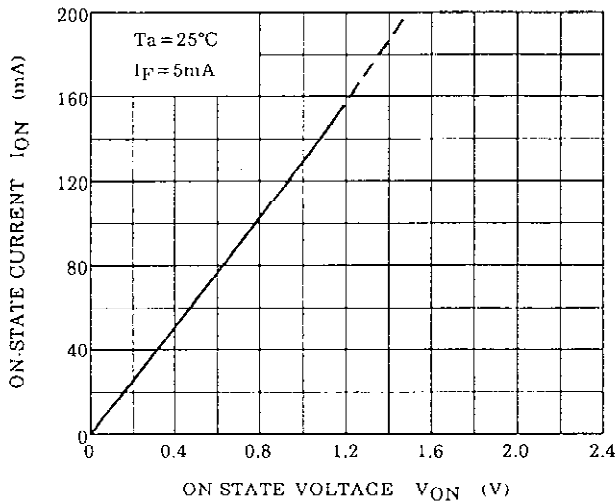

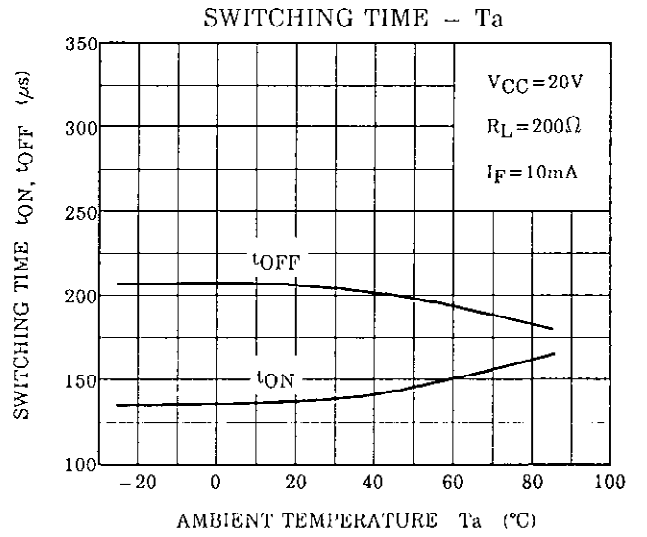
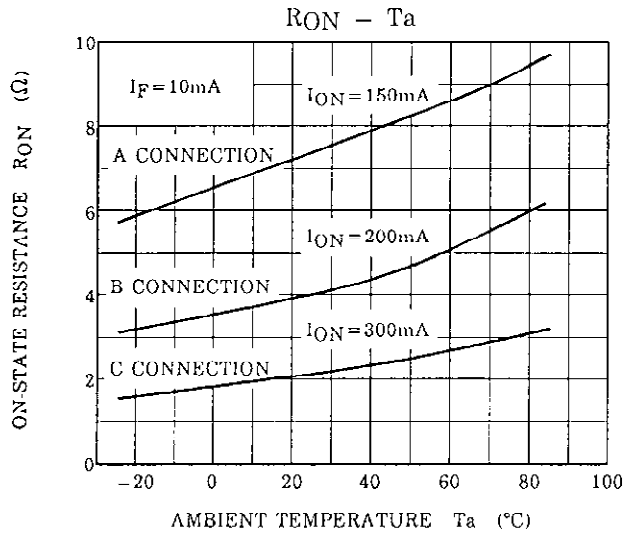
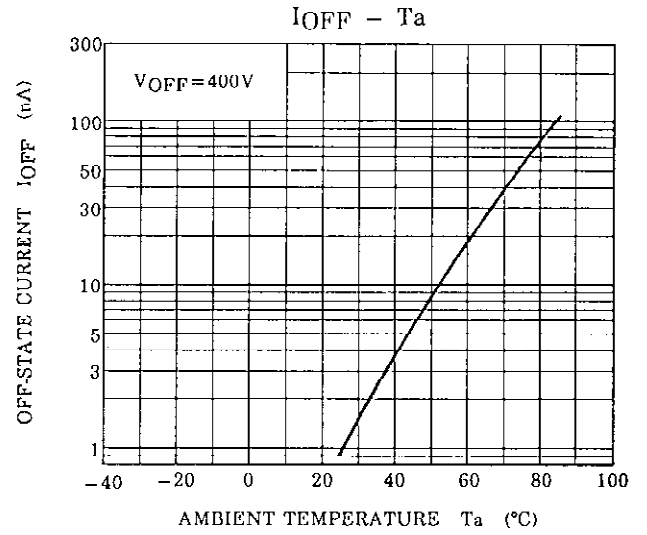
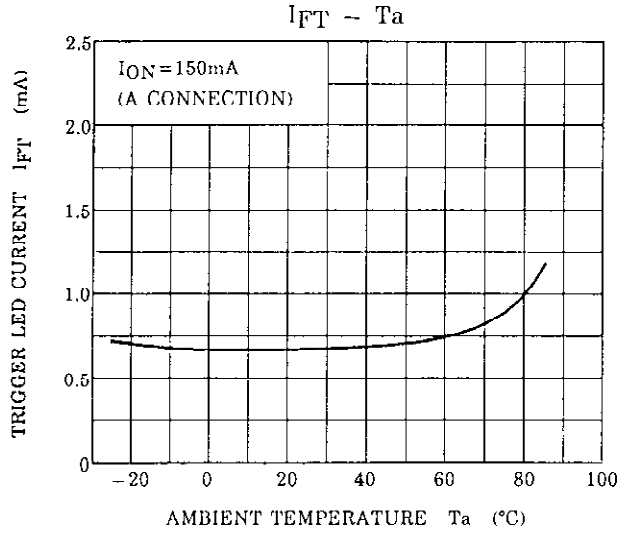

Notes