

TLP557

Transistor Inverter
 Inverter For Air Conditioner
 Power Transistor Base Drive

The TOSHIBA TLP557 consists of a GaAlAs light emitting diode and an integrated photodetector.

This unit is 8-lead DIP package.

TLP557 is suitable for base driving circuit of power transistor module up to 20A.

External resistor needs to connect between pin 6 and pin 7.

This is for constant current driving.

- Input threshold current: $I_F=5\text{mA}(\text{max.})$
- Guaranteed performance temperature range: $-30\sim 70^\circ\text{C}$
- Supply voltage: $16\text{V}(\text{max.})$
- Output current: $\pm 0.3\text{A}(\text{max.})$
- Switching time (t_{pLH} / t_{pHL}): $5\mu\text{s}(\text{max.})$
- Isolation voltage: $2500V_{\text{rms}}(\text{min.})$
- UL recognized: UL1577, file No. E67349

Schematic

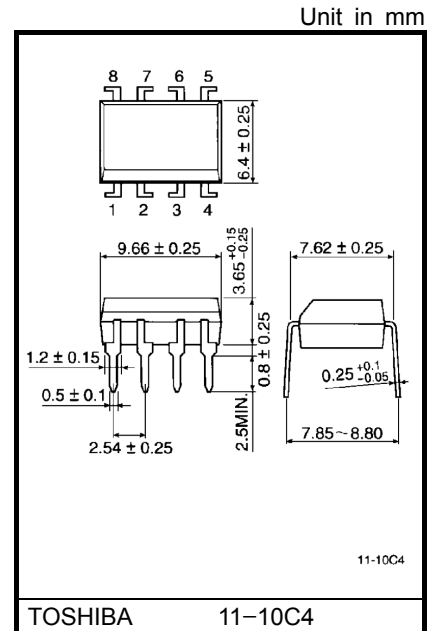
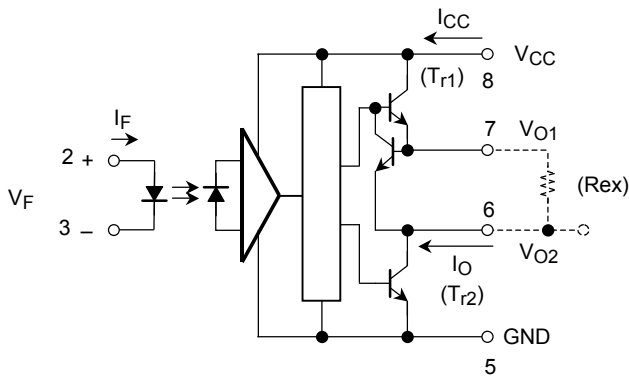

TOSHIBA 11-10C4
 Weight: 0.54g

Pin Configuration (top view)

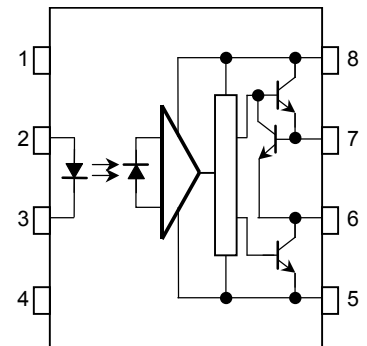

- 1 : N.C.
- 2 : Anode
- 3 : Cathode
- 4 : N.C.
- 5 : GND
- 6 : $V_{O2}(\text{Output})$
- 7 : $V_{O1}(\text{Rex Terminal})$
- 8 : V_{CC}

Truth Table

		Tr1	Tr2
		Input	On
LED	On	On	Off
	Off	Off	On

Absolute Maximum Ratings

Characteristic		Symbol	Rating	Unit
LED	Forward current	I_F	25	mA
	Peak transient forward current (Note 1)	I_{FPT}	1	A
	Reverse voltage	V_R	5	V
	Junction temperature	(T_j)	125	°C
Detector	Output current (f ≤ 5kHz, Duty ≤ 50%)	I_O	+0.32 / -0.32	A
	Peak output current ($P_W \leq 10\mu s$, f ≤ 5kHz)	I_{OP}	+2 / -0.5	A
	Output voltage	V_O	16	V
	Supply voltage	V_{CC}	16	V
	O ₁ terminal to O ₂ terminal (pin 7–pin 6) voltage	V_{1-2}	1.5	V
	O ₂ terminal to O ₁ terminal (pin 6–pin 7) voltage	V_{2-1}	5	V
	Power dissipation (Note 2)	P_o	0.5	W
	Junction temperature	(T_j)	125	°C
Total package power dissipation (Note 3)		P_{OT}	0.55	W
Operating temperature range		T_{opr}	-30~70	°C
Storage temperature range		T_{stg}	-55~125	°C
Lead solder temperature (10 s)		T_{sol}	260	°C
Isolation voltage (AC, 1 min., R.H. ≤ 60%, Ta=25°C) (Note 4)		BV_S	2500	Vrms

Note: Using continuously under heavy loads (e.g. the application of high temperature/current/voltage and the significant change in temperature, etc.) may cause this product to decrease in the reliability significantly even if the operating conditions (i.e. operating temperature/current/voltage, etc.) are within the absolute maximum ratings.

Please design the appropriate reliability upon reviewing the Toshiba Semiconductor Reliability Handbook (“Handling Precautions”/“Derating Concept and Methods”) and individual reliability data (i.e. reliability test report and estimated failure rate, etc).

(Note 1) Pulse width $PW \leq 1\mu s$, 300pps

(Note 2) $\Delta P_o / ^\circ C = -6.7mW / ^\circ C$ ($T_a \geq 50^\circ C$)

(Note 3) $\Delta P_{OT} / ^\circ C = -7.4mW / ^\circ C$ ($T_a \geq 50^\circ C$)

(Note 4) Device considered a two terminal device: Pins 1, 2, 3 and 4 shorted together, and pins 5, 6, 7 and 8 shorted together.

Recommended Operating Condition

Characteristic	Symbol	Min.	Typ.	Max.	Unit
Input current on	$I_F(ON)$	7	8	20	mA
Input voltage off	$V_F(OFF)$	0	—	0.8	V
Supply voltage	V_{CC}	5	6	13	V
I_{B1} Drive current	I_{O1}	—	0.15	0.25	A
I_{B2} Drive current	I_{O2}	—	—	0.5	A
External resistance	R_{ex}	2.7	4.3	—	Ω
$V_{CC}-V_{O2}$ (pin 8–pin 6) ON voltage	V_{8-6}	2.3	3 ($I_{O1} = 0.15A$)	2.5 ($I_{O1} = 0.25A$)	V
Operating temperature	T_{opr}	-30	25	70	$^{\circ}C$

Note: Recommended operating conditions are given as a design guideline to obtain expected performance of the device. Additionally, each item is an independent guideline respectively. In developing designs using this product, please confirm specified characteristics shown in this document.

(R_{ex} is for constant current driving)

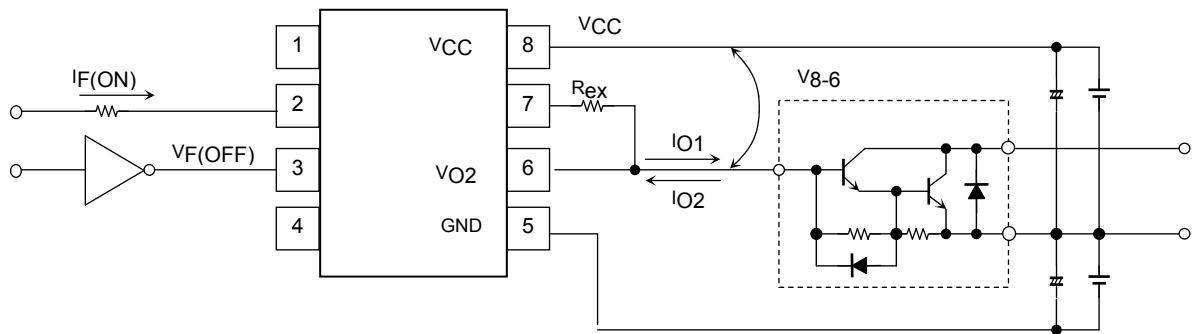

Electrical Characteristics (Ta = -30~70°C , unless otherwise specified)

Characteristic	Symbol	Test Condition	Min.	Typ.*	Max.	Unit	Test Circuit	
Input forward voltage	V _F	I _F = 5mA , Ta = 25°C	—	1.55	1.7	V		
Temperature coefficient of forward voltage	ΔV _F / ΔTa	I _F = 5mA	—	-2.0	—	mV / °C		
Input reverse current	I _R	V _R = 5V, Ta = 25°C	—	—	10	μA		
Input capacitance	C _T	V = 0 , f = 1MHz , Ta = 25°C	—	—	250	pF		
O ₁ Output leakage current	I _{O1L}	V _{CC} = 16V, V _{O1} = 0, V _F = 0.8V	—	0.01	200	μA	1	
O ₂ Output leakage current	I _{O2L}	V _{CC} = 16V, V _{O2} = 16V, I _F = 5mA	—	0.2	200	μA	2	
O ₁ Output current	I _O	V ₈₋₆ = 2.3V R _{ex} = 2.7Ω I _F = 5mA, Ta = 25°C	V _{CC} = 6V	0.22	0.27	0.32	A	3
			V _{CC} = 16V	0.22	0.27	0.32		
O ₂ High level output voltage	V _{OH}	V _{CC} = 6V, R _{ex} = 2.7Ω I _F = 5mA	3.5	5.5	—	V	4	
O ₂ Low level output voltage	V _{OL}	V _F = 0.8V, R _{ex} = 2.7Ω I _O = 0.25A, Ta = 25°C	V _{CC} = 6V	—	0.2	0.4	V	5
			V _{CC} = 16V	—	0.2	0.4		
		V _F = 0.8V, R _{ex} = 2.7Ω I _O = 0.5A (*1) Ta = 25°C	V _{CC} = 6V	—	0.4	—	V	
			V _{CC} = 16V	—	0.4	—		
High level supply current	I _{CCH}	V _{CC} = 6V, I _F = 5mA R _{ex} = 2.7Ω, Ta = 25°C	—	3.8	10	mA		
		V _{CC} = 6V, I _F = 5mA, R _{ex} = 2.7Ω	—	—	13			
		V _{CC} = 16V, I _F = 5mA, R _{ex} = 2.7Ω	—	5.2	17			
Low level supply current	I _{CCL}	V _{CC} = 6V, I _F = 0mA R _{ex} = 2.7Ω, Ta = 25°C	—	11	17	mA		
		V _{CC} = 6V, I _F = 0mA, R _{ex} = 2.7Ω	—	—	22			
		V _{CC} = 16V, I _F = 0mA, R _{ex} = 2.7Ω	—	13	25			
“Output L→H” threshold input current	I _{FLH}	R _{ex} = 2.7Ω I _O = 0.25A V _{O2} > 3V	V _{CC} = 6V	—	2.5	5	mA	
			V _{CC} = 16V	—	—	5		
“Output H→L” threshold input current	V _{FHL}	R _{ex} = 2.7Ω I _O = 0.25A V _{O2} < 0.4V	V _{CC} = 6V	0.8	—	—	V	
			V _{CC} = 16V	0.8	—	—		
Input current hysteresis	I _{HYS}	V _{CC} = 6V, R _{ex} = 2.7Ω, Ta = 25°C	—	0.05	—	mA		
Supply voltage	V _{CC}		5	—	16	V		
Capacitance (input-output)	C _S	V _S = 0, f = 1MHz, Ta = 25°C	—	1.0	2.0	pF		
Resistance (input-output)	R _S	V _S = 500V, Ta = 25°C, R.H. ≤ 60%	5×10 ¹⁰	10 ¹²	—	Ω		

* All typical values are at Ta = 25°C (*1): Duration of I_O time ≤ 100μs

Switching Characteristics (Ta = -30~70°C unless otherwise specified)

Characteristic	Symbol	Test Condition	Min.	Typ.*	Max.	Unit	Test Circuit
Propagation delay time, L→H	tpLH	VCC = 6V, IF = 8mA Rex = 2.7Ω f = 5kHz, Duty = 10%	—	1	5	μs	6
Propagation delay time, H→L	tpHL		—	1	5	μs	
Output rise time	tr		—	0.05	—	μs	
Output fall time	tf		—	0.05	—	μs	
Common mode transient immunity at high level output	CMH	VCM = 600V, IF = 8mA VCC = 6V, Rex = 270Ω R = 1kΩ, Ta = 25°C	-2000	—	—	V / μs	7
Common mode transient immunity at low level output	CML	VCM = 600V, IF = 0mA VCC = 6V, Rex = 270Ω R = 1kΩ, Ta = 25°C	2000	—	—	V / μs	7

* All typical values are at Ta = 25°C.

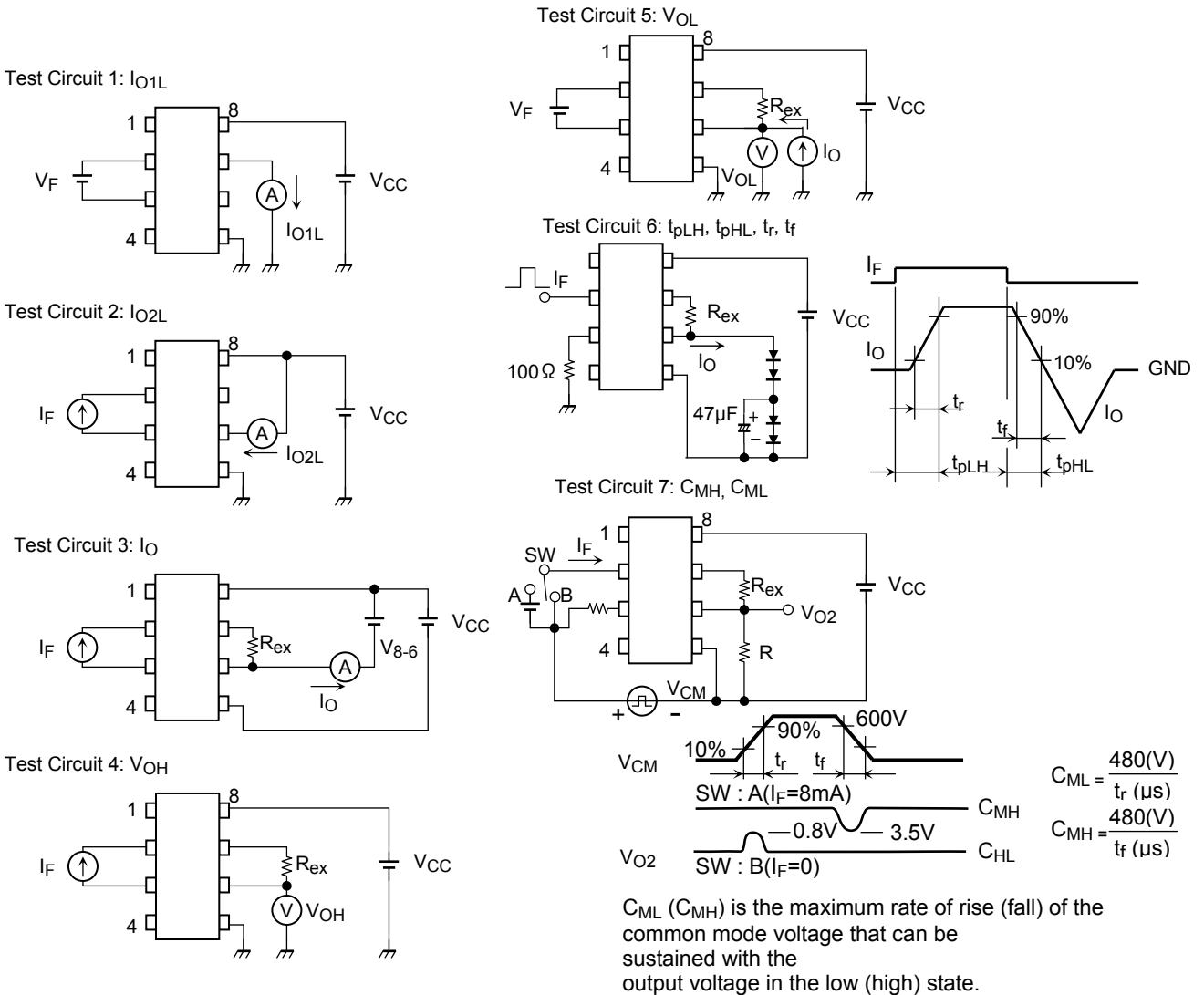

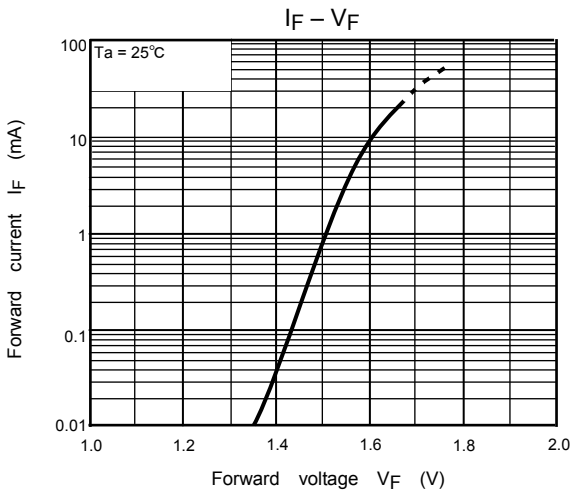
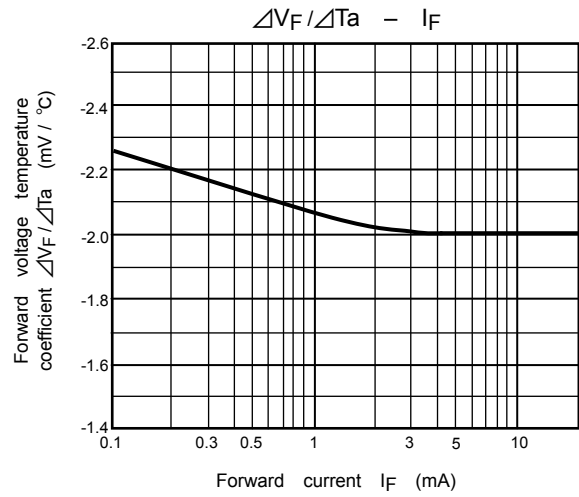
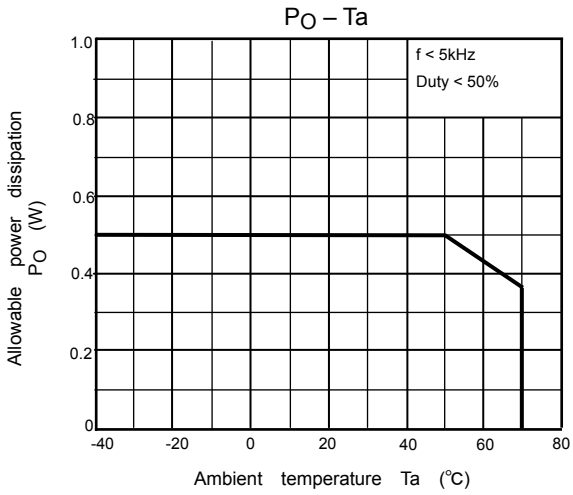

RESTRICTIONS ON PRODUCT USE

20070701-EN

- The information contained herein is subject to change without notice.
- TOSHIBA is continually working to improve the quality and reliability of its products. Nevertheless, semiconductor devices in general can malfunction or fail due to their inherent electrical sensitivity and vulnerability to physical stress. It is the responsibility of the buyer, when utilizing TOSHIBA products, to comply with the standards of safety in making a safe design for the entire system, and to avoid situations in which a malfunction or failure of such TOSHIBA products could cause loss of human life, bodily injury or damage to property.
In developing your designs, please ensure that TOSHIBA products are used within specified operating ranges as set forth in the most recent TOSHIBA products specifications. Also, please keep in mind the precautions and conditions set forth in the "Handling Guide for Semiconductor Devices," or "TOSHIBA Semiconductor Reliability Handbook" etc.
- The TOSHIBA products listed in this document are intended for usage in general electronics applications (computer, personal equipment, office equipment, measuring equipment, industrial robotics, domestic appliances, etc.). These TOSHIBA products are neither intended nor warranted for usage in equipment that requires extraordinarily high quality and/or reliability or a malfunction or failure of which may cause loss of human life or bodily injury ("Unintended Usage"). Unintended Usage include atomic energy control instruments, airplane or spaceship instruments, transportation instruments, traffic signal instruments, combustion control instruments, medical instruments, all types of safety devices, etc.. Unintended Usage of TOSHIBA products listed in this document shall be made at the customer's own risk.
- The products described in this document shall not be used or embedded to any downstream products of which manufacture, use and/or sale are prohibited under any applicable laws and regulations.
- The information contained herein is presented only as a guide for the applications of our products. No responsibility is assumed by TOSHIBA for any infringements of patents or other rights of the third parties which may result from its use. No license is granted by implication or otherwise under any patents or other rights of TOSHIBA or the third parties.
- GaAs(Gallium Arsenide) is used in this product. The dust or vapor is harmful to the human body. Do not break, cut, crush or dissolve chemically.
- Please contact your sales representative for product-by-product details in this document regarding RoHS compatibility. Please use these products in this document in compliance with all applicable laws and regulations that regulate the inclusion or use of controlled substances. Toshiba assumes no liability for damage or losses occurring as a result of noncompliance with applicable laws and regulations.